

## AN ABSTRACT OF THE THESIS OF

Jorie Clark for the degree of Master of Arts in Interdisciplinary Studies in Anthropology, Geography, and History presented on 30 November 1993.

Title: Historical Archaeology of Battery Freeman (ca. 1900-1940), Fort Stevens, Oregon.

Redacted for privacy

Abstract approved: \_\_\_\_\_

This research focuses on events surrounding the activities of Battery Freeman, a coastal defense facility constructed within the earthworks of "old" Fort Stevens near Astoria, OR, in 1900 and destroyed in 1939. Archival data are used in conjunction with nearly 5,000 artifacts that were recovered from archaeological excavations in 1989 by the Oregon State University Field School, to reconstruct the history of the facility. Archival information provided a detailed representation of the spatial setting of Battery Freeman with respect to the original earthworks of Old Fort Stevens. In addition, this information detailed the timing and progress of and materials used in the construction of the battery. Spatial, temporal, and typological analyses were conducted on the artifacts. The great majority of the artifacts are associated with Battery Freeman architecture. Many of these artifacts were homogenously distributed throughout a "fill unit" reflecting the leveling and bulldozing of the site. However, several primary features were preserved, including a remnant of the east bulkhead wall of the pre-1900 structure and an incinerator feature apparently used in the battery. The spatial context of artifacts associated with these features could be interpreted with greater confidence.

©Copyright by Jorie Clark

30 November 1993

All Rights Reserved

**Historical Archaeology of Battery Freeman**

**(ca. 1900-1940), Fort Stevens, Oregon**

**by**

**Jorie Clark**

**A THESIS**

**submitted to**

**Oregon State University**

**in partial fulfillment of  
the requirements for the  
degree of**

**Master of Arts in Interdisciplinary Studies**

**Completed November 30, 1993**

**Commencement June 1994**

APPROVED:

Redacted for privacy

Associate Professor of Anthropology in charge of co-major

Redacted for privacy

Associate Professor of Geography in charge of co-major

Redacted for privacy

Professor of History in charge of co-major

Redacted for privacy

Chairman of Department of Anthropology

Redacted for privacy

Dean of Graduate School

Date thesis is presented 30 November 1993

Typed by Jorie Clark



## ACKNOWLEDGEMENTS

I have been an interdisciplinarian for most of my life - always curious and interested in piecing together the past and learning how things tie in with one another. And so it was that at the age of seven I acquired my father's interests in archaeology, geology, and history. For this enlightenment, I am forever thankful to my beloved father, my friend and mentor.

Between work, family and school - my graduate career has been seemingly long and at times frustrating and unfocused (though I did learn that these feelings were perfectly normal!). At any rate, I have come to the realization that while multiple interests are wonderful, trying to narrow down on a thesis topic could be difficult! Nevertheless, I did select a thesis with the help of my major advisor.

I thank Dr. David Brauner for his expertise, advise, and use of reference materials. A sincere appreciation to Dr. William Robbins who has been so prompt with his editorial comments and suggestions. I thank my other committee members, Drs. Charles Rosenfeld and Jonathan King, for their support. Thanks to friends and colleagues who have cheered me on, with a special note of thanks to Ron Gregory for taking time out of his busy schedule to assist with photographs (guess which ones) and for graciously loaning me his camera gear. I would like to extend my appreciation to Gale Abrams and the staff at the Fort Stevens State Park Museum for their assistance.

But most of all, much gratitude to members of my family for their continued support and faith in me. My son Michael has been wonderful and not demanding of me, timewise. Moreso than ever, I am grateful to my spouse Peter, *ab imo pectore*, for all of his advise, encouragement and assistance. Thank you.

## TABLE OF CONTENTS

<b>CHAPTER 1. INTRODUCTION</b>	1
<i>Previous Historical and Archaeological Investigations</i>	5
<i>Objectives</i>	6
<b>CHAPTER 2. PHYSICAL SETTING</b>	8
<i>Location</i>	8
<i>Geology and Physiography</i>	8
<i>Flora</i>	10
<b>CHAPTER 3. HISTORIC OVERVIEW</b>	13
<i>Background</i>	13
<i>American Settlement</i>	15
<i>History of Old Fort Stevens</i>	16
<i>Phase 1: 1820-1865</i>	16
<i>Phase 2: 1865-1900</i>	17
<i>Phase 3: 1900-1947</i>	22
<b>CHAPTER 4. RESEARCH DESIGN</b>	29
<i>Recovery of Archival Information</i>	30
<i>Field Strategy and Methodology</i>	30
<b>CHAPTER 5. ARCHITECTURE, ARCHIVAL INFORMATION, AND DESCRIPTIVE ARCHAEOLOGY OF BATTERY FREEMAN</b>	38
<i>Battery Freeman Architecture</i>	39
<i>Archival Information</i>	41
<i>Comparative Methods</i>	48
<i>Artifacts</i>	52
<i>Stratigraphic Features</i>	59
<i>Assemblages</i>	66
<i>Assemblage 1: Fill Component - 1900-1940</i>	66
<i>Assemblage 2: Incinerator Feature</i>	67
<i>Assemblage 3: Battery Freeman Floor</i>	70
<i>Assemblage 4: Bulkhead Wall - pre-1900</i>	71
<i>Life at Battery Freeman</i>	72
<b>CHAPTER 6. DISCUSSION AND CONCLUSIONS</b>	74
<i>History of the Fort</i>	75
<i>Archival Information</i>	77
<i>Stratigraphic Information</i>	78
<i>Archaeological Analyses</i>	79
<i>Conclusions</i>	83
<b>REFERENCES CITED</b>	86
<b>APPENDIX A: DESCRIPTION OF ARTIFACTS</b>	92

## LIST OF FIGURES

Figure	Title	Page
1.1.	Location map of the forts that made up the Columbia River Harbor Defense (Forts Stevens, Canby, and Columbia).	2
1.2.	Map of Fort Stevens on Point Adams (after Hanft, 1980).	3
2.1	Location map of 1989 archaeological excavation (ORCLT 1) of Fort Stevens on Point Adams.	9
2.2.	Changes at the mouth of the Columbia River from 1885 to 1957 associated with jetty construction, determined from Coast & Geodetic Survey charts (after Komar and Li, 1991).	11
2.3.	View looking east over area of Fort Stevens on Point Adams showing vegetation. Arrow points to area of former earthwork.	12
3.1.	Nine-sided old earthwork structure, showing location of 26 gun emplacements (from Fort Stevens State Park brochure).	18
3.2.	Photographs of sallyport entrance to interior of old earthwork structure (OHS photographs).	19
3.3.	Post buildings in relation to old earthwork structure (modified from Hanft, 1980).	20
3.4.	Layout of Fort Stevens batteries in relation to old earthwork structure (modified from Fort Stevens State Park brochure).	23
3.5.	Map of Battery Freeman within the old earthwork, showing circular mining casemate adjacent to the old earthwork structure.	24
3.6.	1939 USDA aerial photograph showing golf course adjacent to (south) old earthwork (note ditch). Arrows identify greens on golf course.	26
3.7.	1940 photograph of leveled parade ground as temporary tent campsite. Photograph courtesy of Fort Stevens Museum.	27

## LIST OF FIGURES, continued

- |      |  |    |
|------|--|----|
| 3.8. | Bulldozer tread tracks preserved on sand stratigraphically above feature subsequently excavated in test pit that dates from Battery Freeman.   | 27 |
| 4.1. | Location map of test pits within the old earthworks during the 1989 excavation.  | 33 |
| 4.2. | (A) Oblique aerial photograph showing outline of former earthworks and locations of test pits and backhoe trench. (B) Location of test pits with respect to floor plan of old earthworks and Battery Freeman.  | 34 |
| 4.3. | Photographs of 1989 excavation at Fort Stevens in progress.  | 35 |
| 5.1. | A seacoast battery with major architectural features identified (from Hines and Ward, 1910).   | 40 |
| 5.2. | Photographs of the rear of Battery Freeman showing architectural features associated with its construction. (A) 1938 photograph looking northwest (from Fort Stevens Museum collection). (B) View looking toward northeast (from Hanft, 1980).                               | 42 |
| 5.3. | Example of a 6" gun mounted on a Barbette carriage (from Hines and Ward, 1910).  | 43 |
| 5.4. | Architectural designs of Battery Freeman (from Hanft, 1980).   | 45 |
| 5.5. | (A) Six inch ceramic pipe in Battery Pratt that was used for ventilation of shellrooms, guardroom, and latrines, as well as for access for electric wiring. (B) Eight inch ceramic pipes arising at top of Battery Pratt used for ventilation of magazines.                  | 49 |
| 5.6. | (A) Curved metal I-beam with one flange (left side) wider than the other and holes at the ends. Recovered from the ditch. (B) Curved metal I-beam from Battery Pratt with the same characteristics and dimensions as (A). Their function was to support ammunition trolleys. | 50 |
| 5.7. | (A) Steel cable with metal fasteners recovered from the ditch. (B) Steel cable supported along concrete walls of Battery Pratt by metal fasteners.   | 51 |
| 5.8. | Photograph of typical fill unit sediments, exposed in unit 2.  | 60 |

**LIST OF FIGURES, continued**

<b>5.9.</b>	<b>Photograph of the incinerator feature exposed in the 1989 excavation (unit 1).</b>	<b>62</b>
<b>5.10.</b>	<b>Map of the incinerator feature exposed in the 1989 excavation (unit 1).</b>	<b>63</b>
<b>5.11.</b>	<b>Map showing bulkhead wall feature exposed in the 1989 excavation (unit 9).</b>	<b>64</b>
<b>5.12.</b>	<b>Photograph of the bulkhead wall feature exposed in the 1989 excavation (unit 9).</b>	<b>65</b>
<b>PLATE 1.</b>	<b>Distribution of artifacts OR CLT 1.</b>	<b>(in pocket)</b>

## LIST OF TABLES

<b>Table</b>	<b>Title</b>	<b>Page</b>
5.1.	ARTIFACTS RECOVERED DURING THE 1989 FIELD SEASON.	53
5.2.	PERCENT OF ARTIFACTS WITHIN SEVEN FUNCTIONAL CATEGORIES.	58
5.3.	ARTIFACTS ASSOCIATED WITH INCINERATOR FEATURE.	68
5.4.	ARTIFACTS ASSOCIATED WITH BATTERY FREEMAN FLOOR.	71
5.5.	ARTIFACTS ASSOCIATED WITH THE BULKHEAD WALL.	71

## LIST OF APPENDIX FIGURES

Figure	Title	Page
A-1.	Belt buckle and suspender clip.	93
A-2.	Pocket watch.	93
A-3.	Whole bottles. (3a) medicine (3b) soda and (3c) homeopathic.	97
A-4.	Whole whiskey bottles (4a, 4b).	98
A-5.	Bottles: whiskey (5a, 5d), type unknown (5b), and beer (5c).	98
A-6.	Cork-stoppered medicine bottle.	99
A-7.	Ceramic stopper.	101
A-8.	Brass box latch.	102
A-9.	Types of keys (9a,b,c).	103
A-10.	Examples of architectural artifacts (red clay tile fragments).	104
A-11.	Examples of architectural artifacts (wire).	104
A-12.	Examples of architectural artifacts (hinges).	105
A-13.	Types of nails.	105
A-14.	OR-CLT-1 nail distribution.	107
A-15.	Brick fragments.	108
A-16.	Examples of concrete and mortar.	108
A-17.	Fragments of glass tubing.	109
A-18.	Examples of flat glass.	110
A-19.	Examples of nuts, bolts, and washers.	111
A-20.	Examples of insulators.	111
A-21.	Horseshoe.	112
A-22.	Examples of clinkers and coal.	113
A-23.	Types of ammunition.	114

## LIST OF APPENDIX FIGURES, continued

A-24.	Minie balls (diameter = 0.5").	115
A-25.	Friction primers and pins.	116
A-26.	Front pintle mount.	117
A-27.	Types of buttons.	117
A-28.	Crossed cannon insignia.	118
A-29.	Brass collar pin.	118
A-30.	Examples of oval wire ring handles.	119



**LIST OF APPENDIX TABLES**

<b>Table</b>	<b>Title</b>	<b>Page</b>
A-1.	Summary of Glass Containers within the Interior	96
A-2.	Summary of Whole Bottles	97
A-3.	Summary of Nails Within the Interior	106
A-4.	Flat Glass	110
A-5.	Ammunition	113

# HISTORICAL ARCHAEOLOGY OF BATTERY FREEMAN

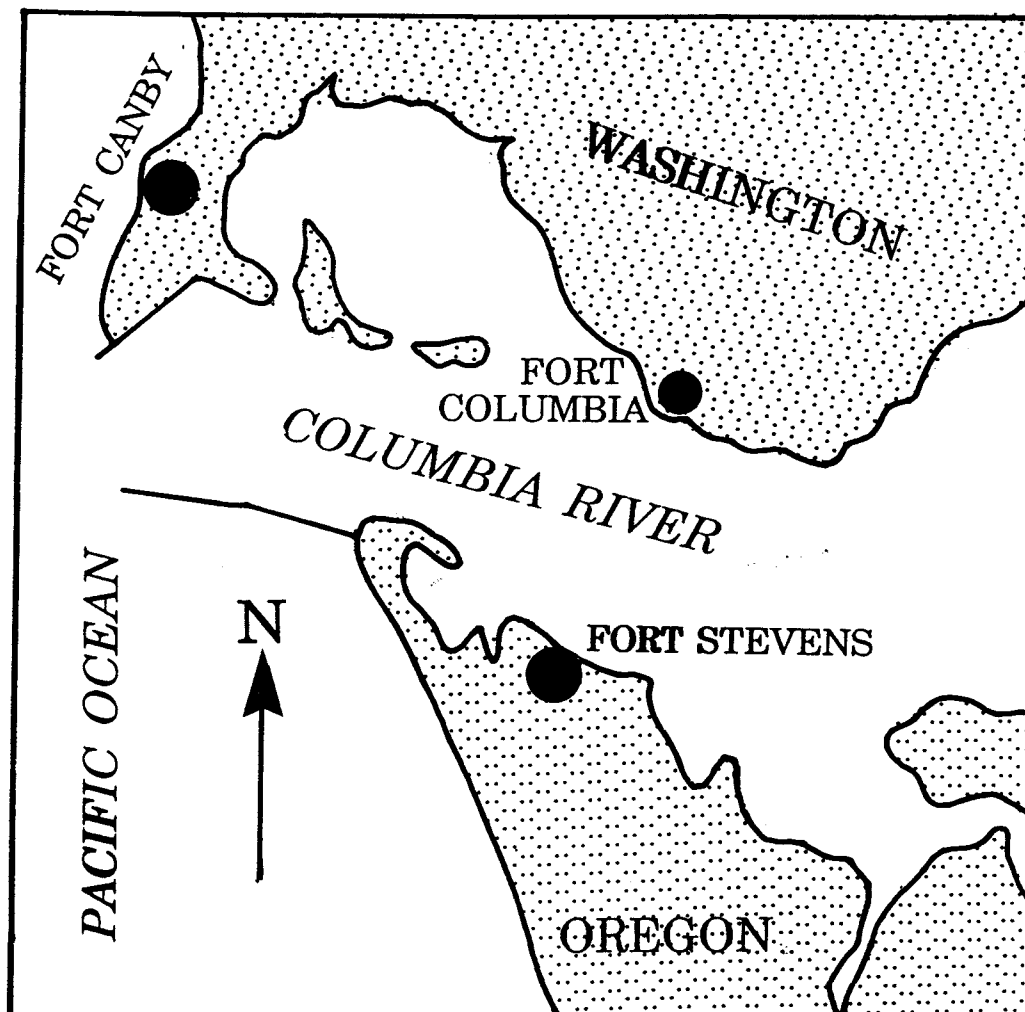
(ca. 1900-1940) FORT STEVENS, OREGON

## CHAPTER 1: INTRODUCTION

As early as the 1820s, the mouth of the Columbia River was identified by the United States government as a potentially strategic area that required some defensive installation in order to lay claim to the land (Hanft, 1980). As late as 1861, however, the West Coast of the United States north of San Francisco had no fortifications (Hanft, 1973). In response to a perceived need for defense of the mouth of the Columbia River against the British Navy (due to her potential support of the Confederacy) and Confederate raiding ships during the Civil War, the government finally approved funding for the construction of fortifications at the mouth of the Columbia River in 1863. One fortification on the south side of the Columbia River (Fort Stevens on Point Adams) and two defensive works on the north side (Fort Canby and Fort Columbia) were approved (Figure 1.1). These fortifications comprised the original defensive system for the mouth of the Columbia River (Hanft, 1986).

In April, 1865, the construction of Fort Stevens was completed on Point Adams, near Astoria, Oregon (Figure 1.2). The use of the fort as a coastal artillery defense installation continued until 1947, when the need for the fort and coastal artillery units in general, became obsolete.

During its life, the fort experienced several periods of inactivity, reconstruction, and expansion. A reluctant Congress was unwilling to provide additional funding for coastal defenses after the Civil War, and Fort Stevens was closed as a military post. During the 1880s, however, Congress again began to fund



**FIGURE 1.1.** Location map of the forts that made up the Columbia River Harbor Defense (Forts Stevens, Canby and Columbia).

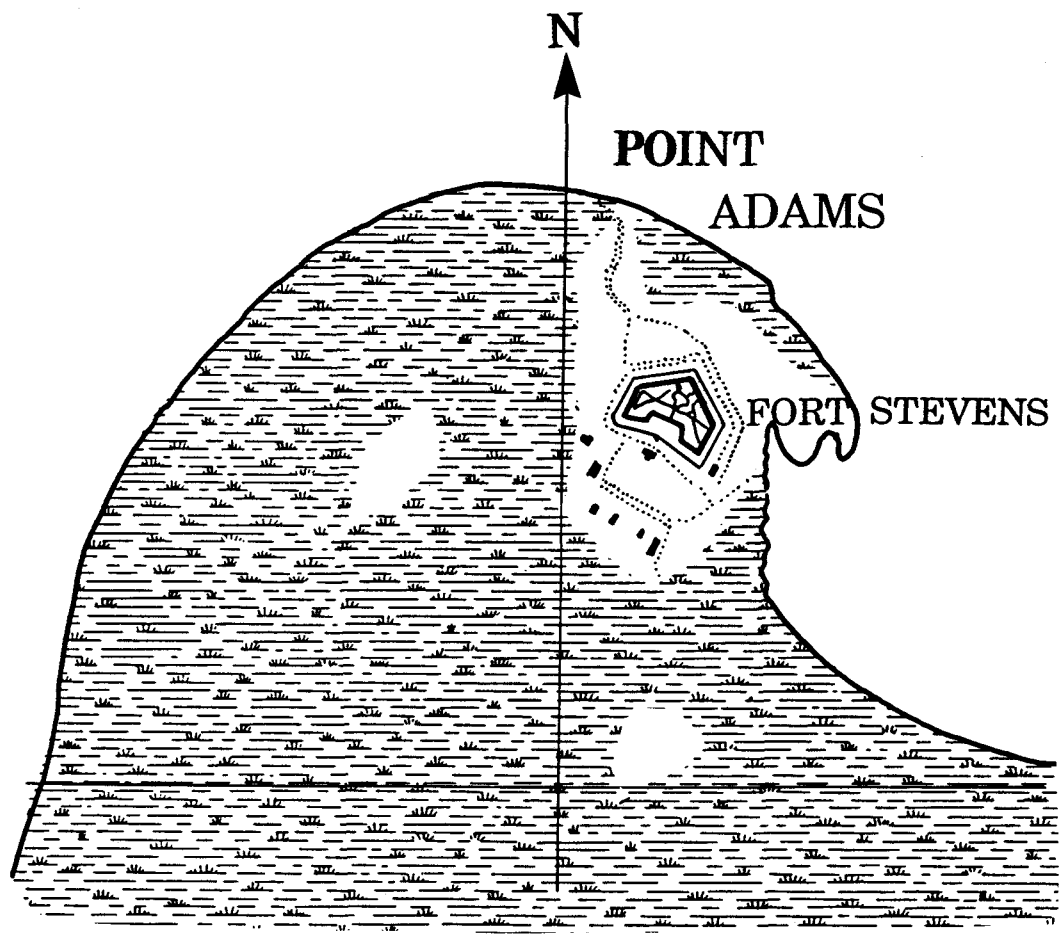


FIGURE 1.2. Map of Fort Stevens on Point Adams (after Hanft, 1980).

coastal defense installations. With the advent of the Spanish-American War in 1898, Fort Stevens was expanded and modernized with new armament and reoccupied by the 3rd Artillery, U.S. Army Corps of Engineers (Hanft, 1980).

Hanft (1973, 1980) and Sekora (1989) have documented in substantial detail the history of the events leading up to and following completion of the Civil War-era installation. In general, this history can be subdivided into three phases: (1) phase I (1820-1865), involving funding and development of the fort; (2) phase II (1865-1900), involving construction and maintenance of the original earthworks structure; and (3) phase III (1900-1947), involving substantial reconstruction of the fort and its use as a temporary campsite for World War II enlistees.

The Friends of Old Fort Stevens in cooperation with Oregon State Parks, the Oregon State Historic Preservation Office, and the Army Corps of Engineers are presently making an effort to reconstruct the original earthworks of the Civil War era "Old" Fort Stevens. Such a reconstruction is of interest to our understanding of the history of coastal fortifications. Since Fort Stevens was listed as a historic site on the National Register of Historic Places in 1973, no ground-disturbing activity could take place prior to an archaeological assessment of the earthworks' site. The initial archaeological investigations at the earthworks' site were designed, therefore, to determine the significance of the resource and formulate a plan to mitigate any negative impacts should the reconstruction prove acceptable and feasible to the federal and state agencies involved.

The archaeological field work at Old Fort Stevens began on June 27, 1989 and was completed August 4, 1989. Field excavations were accomplished by archaeologists from the Department of Anthropology, Oregon State University, under the direct supervision of Dr. David Brauner. Excavations were conducted at

the request of the Friends of Old Fort Stevens and under permit from the Oregon Division of State Lands and the Portland District, Army Corps of Engineers.

The primary objectives of the archaeological excavation were to determine the presence of structural remains and artifacts associated with the earthworks and to determine the feasibility for partial reconstruction of the earthwork. Over 90 percent of the artifacts and most of the architectural remains, however, were associated with the Battery Freeman occupation (ca. 1900-1940). This sample suggested the need for a detailed study of the Battery Freeman occupation.

### *Previous Historical and Archaeological Investigations*

Hanft (1973, 1980) provided an exhaustive and authoritative review of the history of Fort Stevens. Although he discussed aspects of the fort's history, he emphasized the period from construction of the original earthworks until its modernization in 1900.

Harrison and Ross (1989) and Harrison (1990) reported on excavations of the Civil War-era officers' quarters at Fort Stevens during the 1979 and 1980 field seasons. Harrison recovered more than 1,500 artifacts in the 1979 season and 841 artifacts during the 1980 season. Many of the artifacts are representative of living conditions at the fort: building materials, clothing parts, toys, ammunition, tools and other hardware, tableware, kitchen items, and bottle fragments. From this assemblage of artifacts, Harrison (1990) extrapolated information about the architectural detail and domestic life within the officers' compound. He concluded that "the military character of many of the artifacts reflects a pattern recovered at similar posts throughout the Pacific Northwest" (Harrison, 1990:153).

Two important studies conducted immediately prior to the 1989 excavation were those of Sekora (1989) and Bell (1989). Sekora (1989) focused on the

architectural history of the old earthwork from 1863 to 1940 which provided details of its construction and maintenance.

Bell (1989) completed a report to the Friends of Old Fort Stevens which involved the use of remote sensing techniques. Specifically, Bell's (1989) study was designed to locate features of the old fort using color infrared (CIR) photographs, a magnetometer (metal detector), and seismic surveys. The use of aerial CIR photographs helped to detect portions of the ditch and the location of Battery Freeman but could not provide details on other portions of the old fort. While the magnetometer located fifty-three subsurface magnetic objects within the interior of the fort, it could not detect concrete materials or resolve changes in the stratigraphy. The seismic survey successfully located the edges of the moat and provided limited stratigraphic information. Bell concluded that the seismic survey was able to detect subsurface stratigraphic units where the magnetometer could not. Furthermore, he stated that remote sensors are more successful if the type of site has had a considerable amount of ground disturbance similar to events which took place in the interior of the old fort.

### *Objectives*

Most of the prior attention in documenting the background of Fort Stevens has focused on the history and archaeology of the fort in the nineteenth century; there has been relatively little historical or archaeological work on sites or events that occurred between 1900 and the closing and demolition of the fort in 1947. This is an important period in the military history of the United States and its coastal defensive network, particularly as it brackets the two world wars of the twentieth century.

A significant but poorly understood aspect of modifications to the old earthworks involved the construction of Battery Freeman, a concrete artillery facility built within the original earthworks in the early 1900s. In order to present a balanced history of Old Fort Stevens, it is therefore important to reconstruct the events associated with this last (third) phase of the earthworks' existence.

The 1989 excavations of the original earthworks at Fort Stevens resulted in the recovery of many artifacts related to the Battery Freeman phase of the fort's use. In particular, the archaeological excavations recovered 4,854 artifacts relating to Battery Freeman inside the original earthworks. Consequently, there is currently a significant body of archival and archaeological data available for such a study. Those materials form the basis for this thesis.

The purpose of this thesis is first to describe the history of Battery Freeman. The information for this task was derived from archival records in Seattle, Washington, and Portland, Oregon. The second aspect of the research involved analysis and interpretation of the 4,854 artifacts recovered from the 1989 excavations, most of which relate to the Battery Freeman phase. This analysis was then integrated with the archival data to develop a more holistic view of the Battery Freeman period within the old earthworks.



## CHAPTER 2

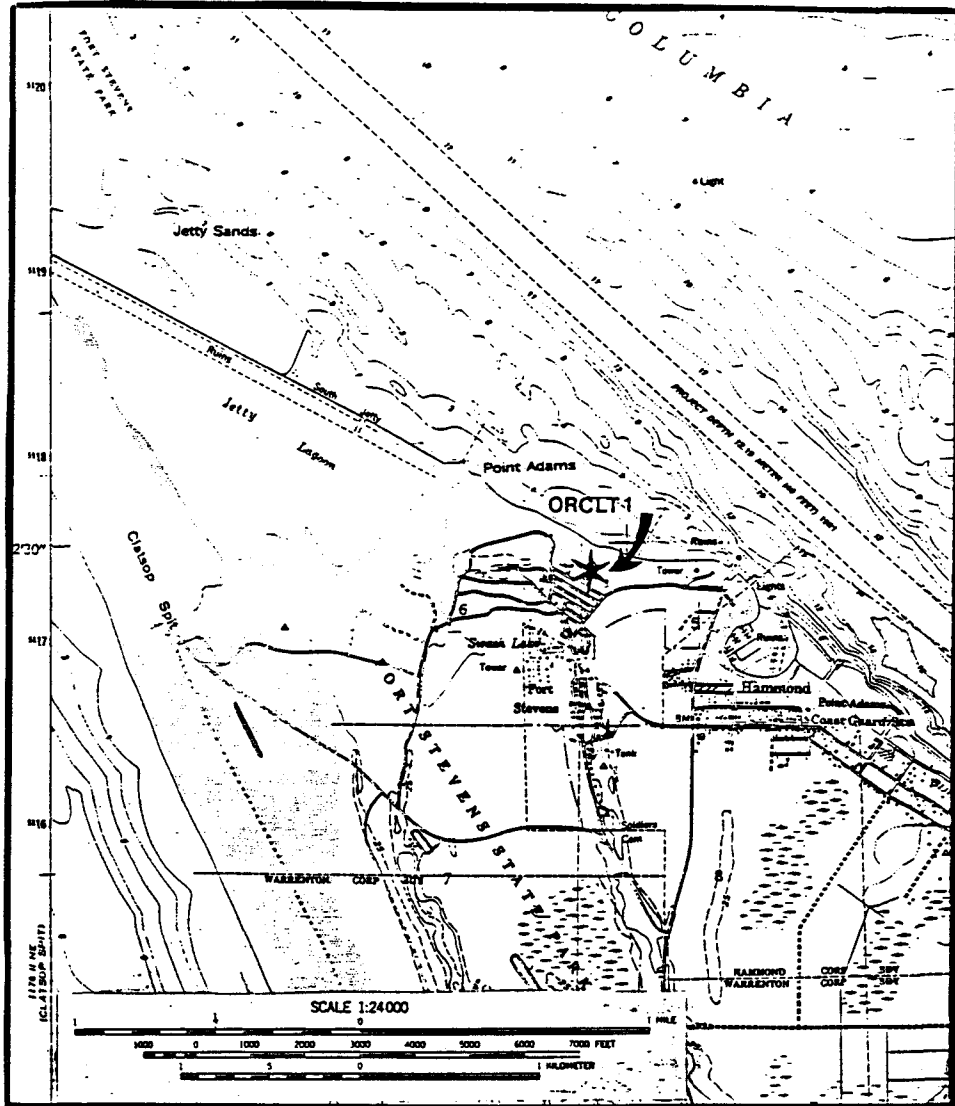
### PHYSICAL SETTING

#### *Location*

Fort Stevens is located on the northwestern tip of Oregon at the mouth of the Columbia River (Figure 2.1). The site is approximately five air-miles northwest of Astoria and is located adjacent to the town of Hammond in the NE 1/4 of the SE 1/4 section of Township 8 North, Range 10 West, Section 6. Fort Stevens has been listed on the National Register of Historic Places since 1973 and is presently under lease from the Army Corps of Engineers to the Oregon State Parks Department.

#### *Geology and Physiography*

The geology of the Fort Stevens area is primarily composed of Tertiary sandstones overlain by unconsolidated Quaternary deposits (Twenhofel, 1946). Approximately 20 million years ago, sandstone was deposited along the present coast from the coastal foothills. The Fort Stevens area (Point Adams) is part of a large spit or bar (Clatsop Spit) comprised of Quaternary beach sands (Komar and Li, 1991). The Quaternary deposits consist of moderately well-sorted, fine to medium-grained quartzo-feldspathic sands with heavy mineral laminae; they also include black winter-beach lag sand deposits up to a few meters thick of magnetite, ilmenite, and other heavy minerals locally developed on the Clatsop Spit (Komar and Li, 1991). The Quaternary sediments also include basalt gravels of well-rounded pebbles, cobbles, and boulders around Miocene basalt headlands along southern coast of the Clatsop County (Niem and Niem, 1985). Much of the current



**FIGURE 2.1.** Location map of 1989 archaeological excavation (ORCLT 1) of Fort Stevens on Point Adams.

western half of the Fort Stevens State Park is extensive sandflats that accreted after the construction of the south jetty (1885-1889) (Figure 2.2). This accretion has resulted in a significantly different landscape in the vicinity of Fort Stevens than when it was initially constructed.

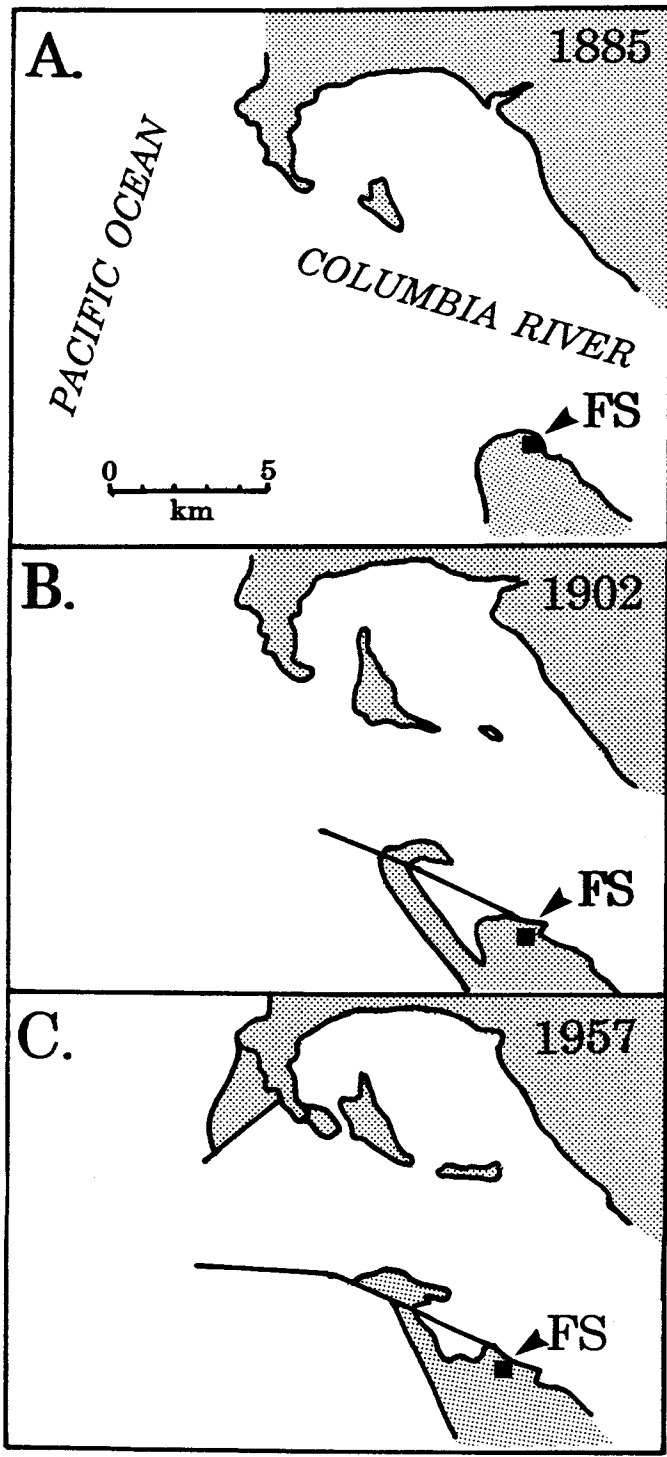
Relief in the immediate vicinity of Fort Stevens ranges from 0 to 30 feet above sea level. A reconnaissance in 1863 made by Captain George Elliot, Corps of Engineers, determined that the fort should be constructed on "a ridge... which had a summit of 30 feet above sea level" (Hanft, 1980:36).

Climate data from 1850-1896 show mean annual temperatures ranging from 48.4°F-53.6°F, with lows in the 10's-20's and highs reaching the 80's (Pague, 1897). Annual precipitation ranged from 43 to 100 inches during this period (Pague, 1897). Climate data from 1985 show similar ranges (U.S. Department of Commerce, 1985). Because of the low topography and high rainfall, the area is commonly marshy or wet throughout most of the year.

### *Flora*

The landforms around the fort are characterized by marshy and wetland forests. As described in 1871 by historian Francis Fuller Victor, the area was "interspersed with ponds and swamps and thickly overgrown with spruce, hemlock and other trees of similar type...wild roses willows and spiraca in areas that have been cleared" (Victor, 1872:39).

Vegetation (Figure 2.3) consists of deciduous trees such as red alder (*Alnus rubra*), weeping willow (*Salix babylonica*), Oregon crabapple (*Malus fusca*), cascara (*Rhamnus purshiana*), elderberry (*Sambucus canadensis*) and Sitka Spruce (*Picea sitchensis*). Salal (*Gaultheria shallon*), grasses, kinnikinnick (*Arctostaphylos uva-ursi*) and wild strawberry (*Fragaria virginiana*) are found along brushy areas.



**FIGURE 2.2.** Changes at the mouth of the Columbia River associated with jetty construction, determined from Coast & Geodetic Survey charts (after Komar and Li, 1991).



**FIGURE 2.3.** View looking east over area of Fort Stevens on Point Adams showing vegetation in 1989. Arrows point to area of former earthwork.

## CHAPTER 3

### HISTORIC OVERVIEW

In 1792, Captain Gray of Boston on the ship *Columbia* discovered the mouth of the [Columbia] River in latitude 46 19' North. She entered it with difficulty because of sand bars and breakers... (Miller, 1958:28)

#### *Background*

As one of the last maritime frontiers, the Columbia River has played a significant role to the history of the Pacific Northwest. Beginning in the sixteenth century, exploratory voyages were made along the coast of the Pacific Northwest by explorers and merchants, primarily in search of new lands for trade and commerce. It was not until the eighteenth century, however, that explorers and traders from Russia, Spain, Great Britain, France and the United States renewed their interests in the region, motivated by what Schwantes refers to as "the three C's of empire: curiosity, conquest, and commerce" (1989:39). Captain Robert Gray of the United States made the first Euro-American discovery of the Columbia River in 1792 while trading for furs (Schwantes, 1989:46). It was Gray's discovery, as well as the overland expedition of Lewis and Clark in 1804-1806 from Missouri to the Pacific Coast, that led to U.S. claims of the Oregon Territory (Schwantes, 1989). These two significant explorations ultimately paved the way for trade, commerce, and the establishment of Astoria in 1811, which was the earliest Euro-American settlement in Oregon.

During the late eighteenth and early nineteenth centuries, fur traders and trappers ventured along major watercourses in search of beaver. As the fur trading industry flourished, various companies formed and, as a result, competition emerged.

In particular, the American Fur Company, which was founded by a German immigrant to the U.S., John Jacob Astor, rivaled the British-based Northwest Company. Described as a man of "outstanding entrepreneurial talent" (Johansen and Gates, 1957:121), Astor invited the Northwest Company to take a one-third interest in the Pacific Fur Company but they at first had rejected the offer. It was not until 1810 that a "tentative agreement was drawn up between Astor and three former Nor'westers... to form the Pacific Fur Company" (Johansen and Gates, 1957). Astor eventually commissioned a group of Americans to establish a trading center at the mouth of the Columbia River. Shortly after the group arrived at the present site of Astoria, however, the war of 1812 with England broke out and Astor's plans for a trading center were abandoned (Schwantes, 1989). There were two major companies during the subsequent fur trade industry, beginning with the Northwest Company of Montreal (1812-1821), which was bought out by the Hudson's Bay Company, which remained active in the fur trade until 1846 (Schwantes, 1989).

For decades, there were territorial disputes over the Oregon country. In 1818, and again in 1827, Great Britain and the United States held conventions over establishing a boundary, but in both cases, "failed to produce agreement" (Schwantes, 1989:59) other than to claim the Oregon country jointly. By the mid-1840s, political forces in the United States gathered under the expansionist doctrine "Manifest Destiny", leading to a pressing need to define the international boundary between the British and the American territory (Schwantes, 1989). Thus, in June, 1846, Great Britain and the United States divided the Oregon country along the 49th parallel, the present international boundary (Schwantes, 1989).

Early boundary disputes between the British and the United States raised concern in the Congress that the U.S. should establish a presence in the Oregon country in order to claim ownership of the area. This concern over the presence

Through the increased volume of shipping on the Columbia River, Clatsop County was exposed to direct contact with world ports and markets (Baker, 1940).

As towns and cities in Clatsop County grew, the residents felt a need for military protection from the nearby Clatsop Indians and, to a larger extent, from fear that Confederate and British gunboats would enter the Columbia River (Miller, 1958). Tensions mounted as the country entered the Civil War (Schwantes, 1989). Military forts such as Fort Columbia, Fort Canby, and Fort Stevens, all located at the mouth of the Columbia River, were thus constructed to protect the settlers and to defend the Columbia River against the Confederates and British.

### *History of Old Fort Stevens*

Based on major events affecting the development and history of Fort Stevens, we can identify three major phases that encompass the time leading up to and following construction of the original earthworks.

#### *Phase 1: 1820-1865*

This phase largely involves events described above, i.e., political disputes and economic development in the Pacific Northwest that led to heightened concerns by the Congress to establish a military presence. In particular, the U.S. Congress became increasingly interested in providing some military protection to the growing number of settlements, particularly along the Columbia River, after the new state of Oregon was established in 1859.

These combined concerns, when added to the previous attempts over the years to establish fortifications, finally resulted in construction of a fort on the south side of the mouth of the Columbia River in 1863. Captain George Elliot, who



supervised construction of the fort, named it after General Isaac Ingalls Stevens, former governor of the Washington Territory (Sekora, 1989).

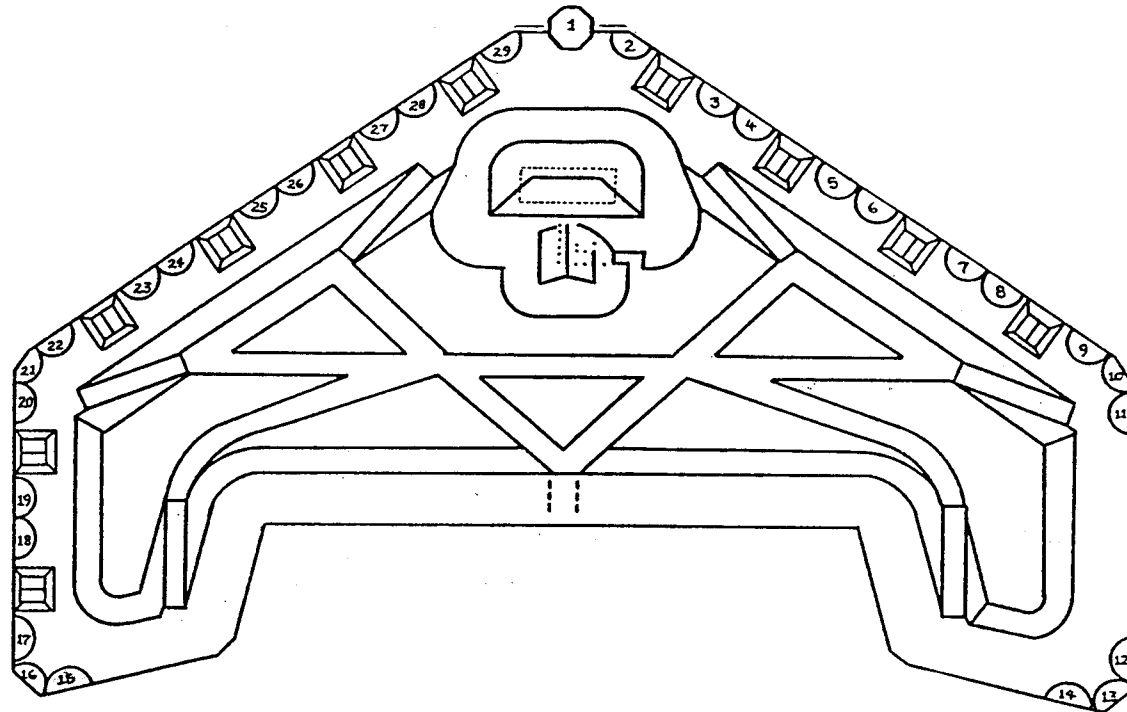
### *Phase 2: 1865-1900*

The original Fort Stevens, built at Point Adams, "was quite standard for the time" (Hanft, 1980:35) (cf. Hines and Ward, 1910). The fort was a nine-sided earthwork of parapet and ditch (Figure 3.1). Two sides, forming a broad V-shape, faced the Columbia River. The entire earthwork was surrounded by a ditch, eight-feet deep, thirty-feet wide expanding to sixty-feet wide on the southern facade (Hanft, 1980). Although the ditch was meant to be dry, it was often filled with water because of the poor drainage and high water table in the area. Because it was often filled with water, the ditch has been commonly referred to as a moat. In this thesis, however, I retain the use of the term "ditch".

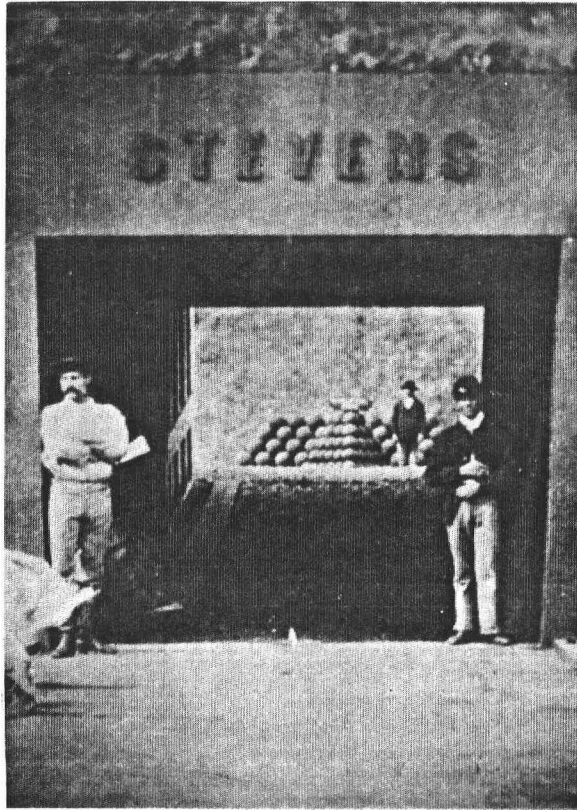
Due to time and funding constraints, the fort was constructed with wooden supports instead of masonry revetments (Sekora, 1989). The wooden supports served as an internal framework that was covered by sand and turf. Although forty-three guns were originally planned for the fort, only twenty-six guns were placed in the structure (Figure 3.1).

The entrance to the fort was through a covered sally-port that faced south through the rear wall (Figure 3.2). Post buildings were located inland, or south of the fort (Figure 3.3). Hanft (1980:62-67) provides a detailed description of these buildings.

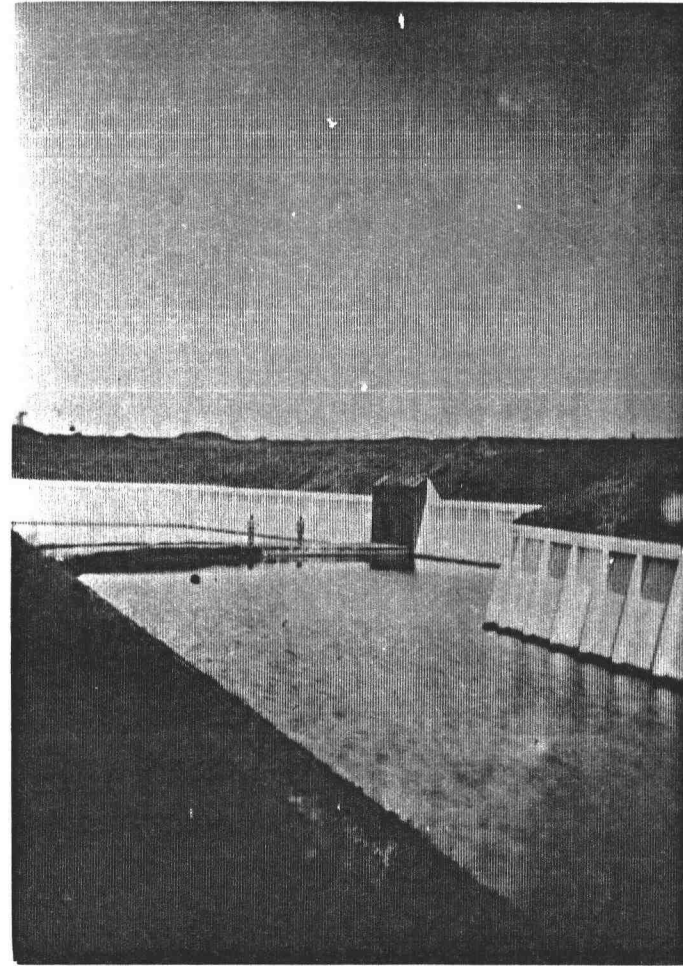
Beginning with the first excavations at the fort site, engineers encountered a shallow water table. Standing water remained a serious problem throughout the life of the fort, but particularly during this phase of its history. In particular, two immediate and continuing problems involved (1) inadequate water drainage and (2)



**FIGURE 3.1.** Nine-sided old earthwork structure, showing location of 26 gun emplacements (from Fort Stevens State Park brochure).

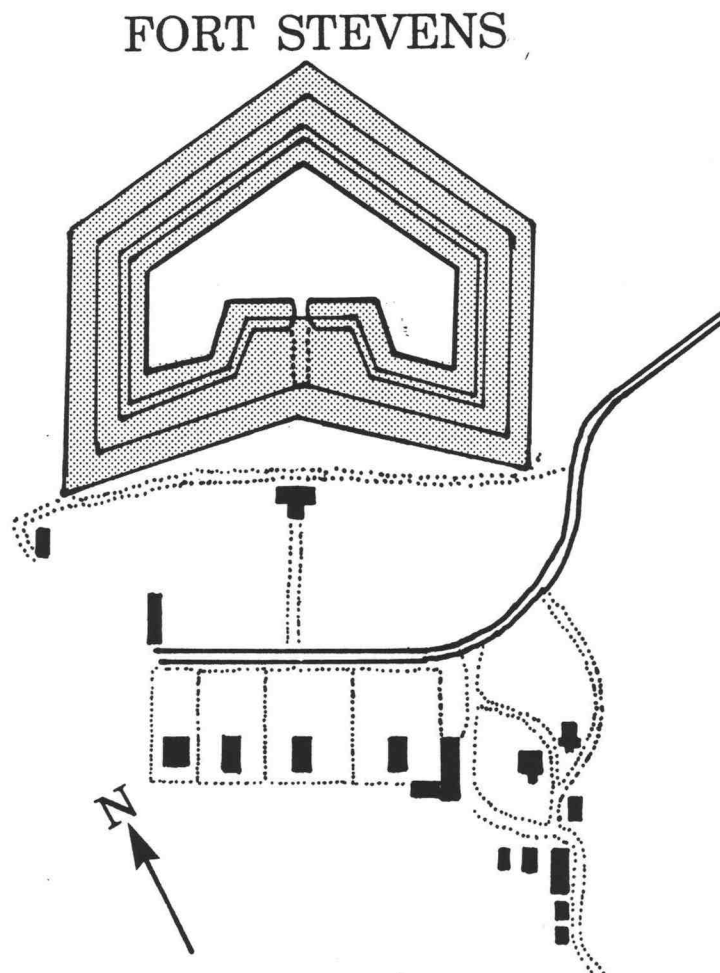


(A)



(B)

FIGURE 3.2. Photographs of sallyport entrance to interior of old earthwork structure (OHS photographs).



**FIGURE 3.3.** Post buildings in relation to old earthwork structure (modified from Hanft, 1980).

decay to the wooden framework (Hanft, 1980). Beginning in 1867, frequent repairs and replacements of the wooden structure and associated earthen embankments were required (Sekora, 1989). According to Sekora (1989:16), "a report...dated October of 1874, stated that the whole work would be completely unserviceable in a few more years if repairs were not made soon".

With the United States still recovering financially from the Civil War, Congress was unwilling to provide additional funding for coastal defenses, "despite the abundant evidence that the casemated forts were obsolete" (Sarty, 1988:36). A twenty-year absence of large-scale coast defense construction followed and much-needed improvements at Old Fort Stevens did not occur.

In 1884, 1st Lt. R.T. Yeatman oversaw the closing of Fort Stevens as a military post and its transfer to the Corps of Engineers (Hanft, 1980; Sekora, 1989). However, during the period of inactivity, the guns remained in place and the Corps "maintained the earthwork and used the post buildings as a base of operations during the construction of the south jetty" (Sekora, 1989:16).

During the 1880s, however, increasing concern about the "growing strength of potentially hostile British and European ironclad fleets began to have an influence on Congress" (Sarty, 1988:37). In 1885, the Board on the Fortifications or Other Defenses of the United States was formed under the chairmanship of Secretary of War William C. Endicott. The following year, the Endicott Board proposed a significant expansion of coastal defense facilities with modernized heavy ordnance, giving priority to "the protection of commercial harbors and trade" (Sarty, 1988:38). Congress approved funding for such expansion, and beginning in 1888 the U.S. Army built a heavy ordnance factory and the fortification of coastal defense facilities was initiated (Floyd, 1985; Sarty, 1988).

Following the Spanish-American War of 1898, there was a renewed interest in Fort Stevens as a defensive fortification. This interest led to the expansion and modernization of the facilities, and the fort was reoccupied by the 3rd Artillery (Hanft, 1980).

### *Phase 3: 1900-1947*

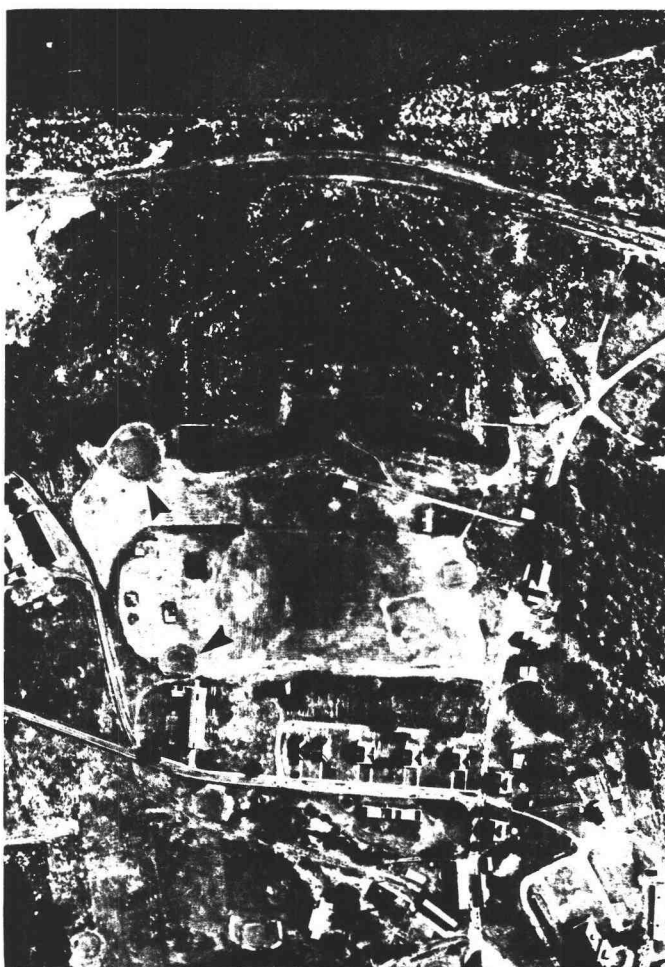
The modernization of Fort Stevens involved the construction of several new concrete batteries. These were named Batteries Mishler (completed in 1900; officially named in 1906), Lewis (1900), Walker (completed in 1900; officially named 1909), Pratt (completed in 1900; officially named in 1906), Smur (completed in 1900; officially named in 1904), Clark (1900), Russell (1900), and Freeman (completed in 1902; officially named in 1904) (Hanft, 1980) (Figure 3.4).

The battery central to this research was constructed directly within the Old Fort Stevens earthwork (Figure 3.5). This new battery was named after Lt. Col. Constant Freeman who served in the U.S. Army during the Revolutionary War and the War of 1812 (Hanft, 1980). Constant Freeman had an impressive military background with nearly forty years in the service. He entered the service as a First Lieutenant in Stevens' Battalion of Artillery on November 9, 1776, and on October 1, 1778, he was made Captain Lieutenant when his battalion was incorporated into the Third Continental Artillery. After a 1794 congressional act resulted in the organization of the Artillerists and the Engineers, Freeman's experience and knowledge of his duties in Crane's Regiment during the Revolution led to his promotion to Major. In the reorganization of the army in 1802, the Artillery and Engineers were separated and Freeman was promoted to Lieutenant Colonel of the Artillery. Freeman received a brevet of Colonel on July 10, 1812, was honorably discharged in June, 1815, and died on February 27, 1824 (OHS, vertical file # 8).

Several modifications were made to the original earthworks to prepare the structure for the new armament. While it appears that most of the original cannon that dated from the Civil War era were sold for scrap in 1900 (Hanft, 1980), a report showing the Fort Stevens inventory for the year ending June, 1900, included two serviceable fifteen-inch smooth bore guns (Lindstrom, 1993). In addition, "usually one old Rodman was exchange[d] for the converted [8"] rifle and then mounted on the same carriage" (Lindstrom, 1993). The converted rifles were probably located on the side of the earthworks that faced down river. Permission was granted to dismount and remove the fifteen-inch gun to make room for the construction of Battery Freeman in 1901.

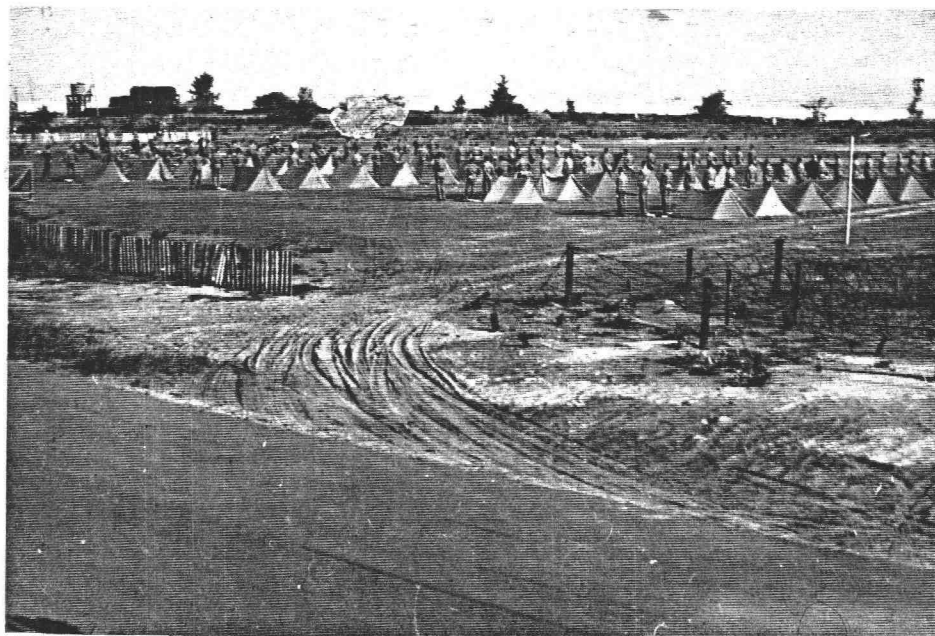
The earthwork's right flank was breached in 1898 by a circular mining casemate (Figure 3.5). The decayed timbers of the sallyport were torn out in 1899 and the slopes were resodded. The entrance through the sallyport was replaced by an open cut through the wall and a new bridge was built across the ditch, "connecting with a new planked roadway put down in place of sallyport" (Hanft, 1980:161; Sekora, 1989). Finally, concrete emplacements for new guns were built inside the original earthworks, including emplacements for two six-inch guns on the left side of the earthwork's interior and for a fifteen-pound rifle on the right side of the interior (Hanft, 1980) (cf. Hines and Ward, 1910).

Battery Freeman remained in use until 1920 when the structure was abandoned and the surrounding ditch was used as a dump (Sekora, 1989). A newspaper article in the *Oregon Daily Journal* (1936), reports that the Civilian Conservation Corps cleared the ditch of debris in 1936. As shown by an aerial photograph, a golf course was in use adjacent to the earthwork in 1939 (Figure 3.6). In 1940, the parapet walls of the earthwork and Battery Freeman were destroyed in order to construct a parade ground for renewed activities at Fort Stevens

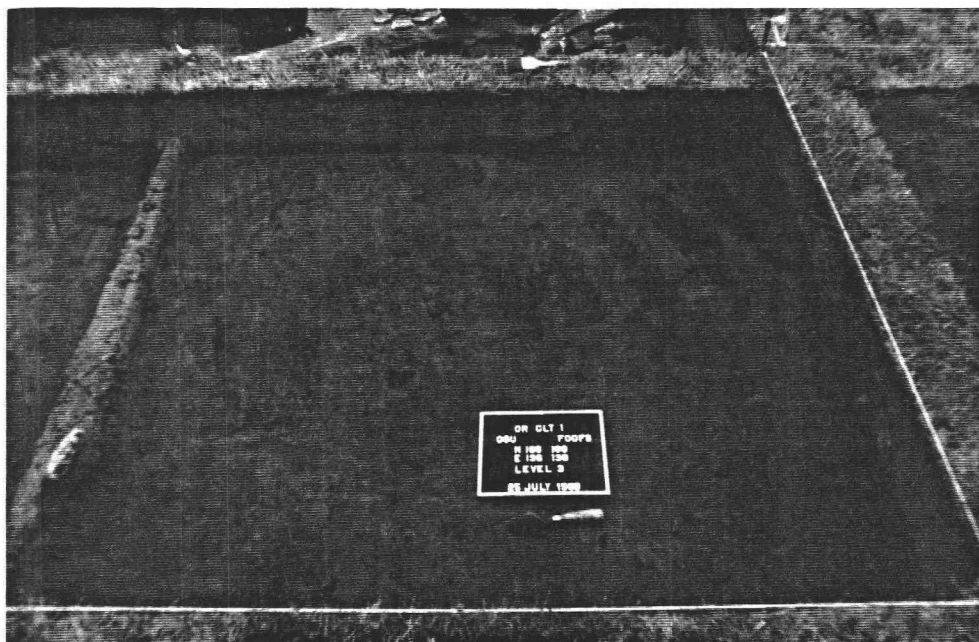


**FIGURE 3.6.** 1939 USDA aerial photograph showing golf course adjacent to (south) old earthwork (note ditch). Arrows identify greens on golf course.





**FIGURE 3.7.** 1940 photograph of leveled parade ground used as a temporary tent campsite. Photograph courtesy of Fort Stevens Museum.



**FIGURE 3.8.** Bulldozer tread tracks preserved on sand stratigraphically above a feature subsequently excavated in this test pit that dates from Battery Freeman.

associated with World War II (Hanft, 1980) (Figure 3.7). During this process, the concrete work associated with Battery Freeman as well as the battery itself, were blown up and the remains were pushed into the ditch (Sekora, 1989). We found evidence of this event during the 1989 excavation in the form of bulldozer tread tracks (Figure 3.8) preserved stratigraphically above a feature (incinerator feature described in Chapter 5) dating from the Battery Freeman phase. In 1947, the Fort Stevens military reservation "was declared a surplus facility by the U.S. Army and turned over to the Corps of Engineers" (Sekora, 1989:19).

## CHAPTER 4

### RESEARCH DESIGN

Historical archaeology involves research on sites from the historic period "in which the broader base provided by ethnographic and historical data is used" (South, 1977:1). Archival data provide one of the critical advantages where these data can be used as controls for interpreting the archaeological data (Beaudry, 1988). Babits (1988), for example, underscored the importance of using military records in historical archaeological studies. Specifically, he argued that "the use of certain military documents can identify patterning in the archaeological record and suggest how representative of the population within a region the documents may be" (p. 119).

Historical archaeology studies of former military facilities have provided important information on life and activity and significantly broadened the historical record. Harrington (1978), for example, provided a detailed reconstruction of a fort dating from the Seven Years War and provided information that supplemented the limited and poorly documented historical record of the fort. Based on spatial and temporal characteristics of artifacts from a fort dating to 1780, Ferguson (1977) was able to identify different functions and activities within the fort, including socioeconomic divisions by rank and class. Evaluation of the type and distribution of lead balls used for rifles led to a better understanding of a battle between British and American soldiers. Bowyer's (1992) research involved comparing the material culture of enlisted men and officers from Fort Hoskins, Kings Valley, Oregon. His study contributes to the understanding of military status and authority differences as observed in the archaeological record.

An analysis of the archival and archaeological records of Battery Freeman provides both a detailed historical record of events involving the battery and helps identify important functional and cultural aspects of human activity in the facility. While it is the pre-1890 earthwork that is currently being reconstructed, gaining insights about its successor (Battery Freeman) from the available archives and artifacts are important to developing a complete history of the earthworks through its three historical phases.

Because archival records are available, the results from this study will be important for evaluating the artifacts in a relatively controlled situation. The results from this study may therefore be of significance to other archaeological studies of similar materials.

#### *Recovery of Archival Information*

In general, there were few archival data relating to Battery Freeman available in the resources investigated (Oregon Historical Society; Fort Stevens Museum; National Archives, Seattle; State Archives, Salem; Oregon Military Museum, Clackamas). In addition, I recovered the names of a number of personnel who served at Fort Stevens between 1900-1940 from a guest registry at the Fort Stevens Museum, but was unable to contact any of them. Nevertheless, the archival data that were available offer important information on the architectural design of and materials used in Battery Freeman.

#### *Field Strategy and Methodology*

The primary objectives of the 1989 Oregon State University archaeological excavation were: (1) to determine if there were any remains of the pre-1900 earthwork and associated occupation; (2) to assess the research and interpretive

potential of the site; (3) to assess the feasibility of a partial or total reconstruction of the earthwork for interpretive purposes; and (4) to provide long-term management recommendations (Brauner, n.d.). The recovery of a significant archaeological component representing the Battery Freeman phase resulted in an additional, if unanticipated, element to the original goals of the excavation.

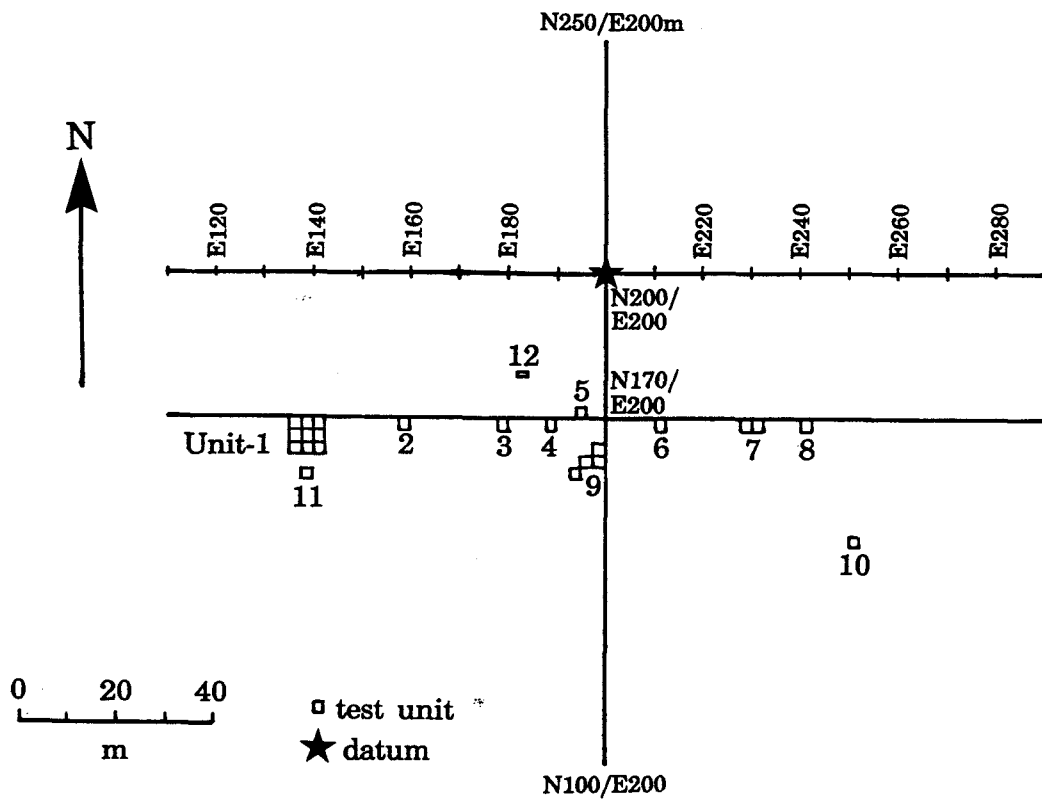
Since the present ground level of the area excavated is only 10 to 15 centimeters above the original elevation of the interior parade ground of Old Fort Stevens, we were not optimistic that we would find any intact features or artifacts within the earthworks, given known disturbance of the site associated with construction and demolition of Battery Freeman. The surrounding superstructure (parapet walls, powder magazine and gun emplacements) were obviously gone. The 10 foot deep water-filled moat, which was 30 feet wide around the periphery of the earthworks and 60 feet wide along the front (south) of the structure, had been filled when the site was leveled. As a consequence, we were certain that significant archaeological remains would be preserved in the moat (Brauner, n.d.).

Based on our knowledge of the demolition of Old Fort Stevens, nothing above the level of the original interior parade ground would have survived. Whether or not remnants of features and artifacts associated with the pre-Battery Freeman earthworks still existed in the parade ground area was uncertain. We expected to find the remnants of Battery Freeman and any cultural remains associated with the parapet walls in the ditch fill. Below the fill, we assumed that the sediment and cultural material which accumulated in the bottom of the ditch during the occupation period of the earthwork would still be intact. We also knew that the ground water table should be well above the original bottom of the ditch (Brauner, n.d.).

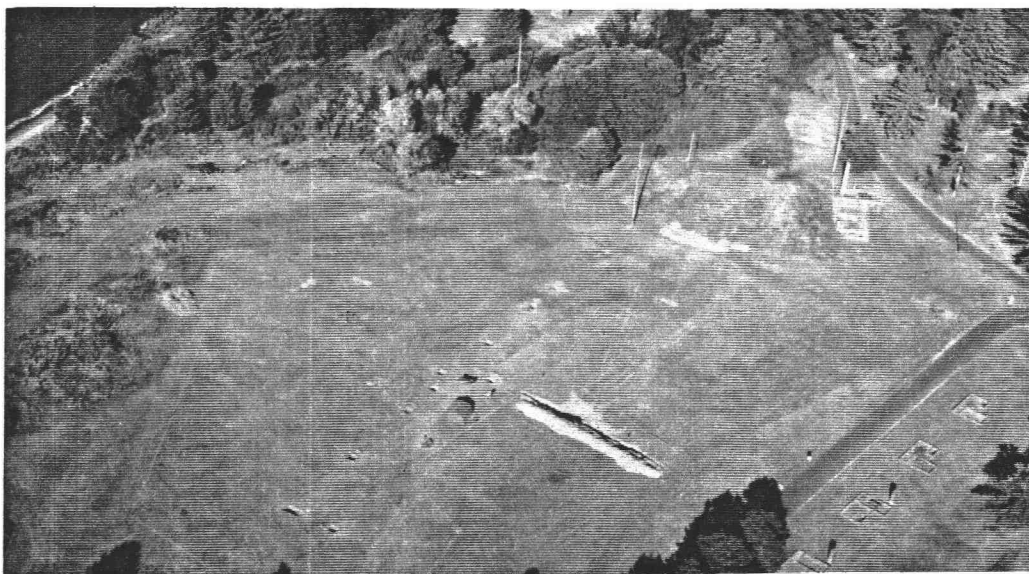
Based on this information, we formulated several hypotheses: (1) that the lower portion of the ditch was still intact; (2) that most of the garbage purposely deposited in the ditch would have originated from the entry bridge; and (3) that a high water table may have preserved normally perishable materials thrown into the ditch (Brauner, n.d.). Also, if any interior remnant of the pre-1900 fortification still remained - it would be located between Battery Freeman and the south parapet walls. These hypotheses then directed our strategy for locating our test pits. Accordingly, eleven 2x2 meter test pits were aligned along an east-west axis across the original interior parade ground and sallyport entrance (Figures 4.1, 4.2, 4.3). Two test pits, which are not discussed in this thesis as they revealed only sterile material, were also placed in the vicinity of the original powder magazine near the salient angle and one test pit over the concrete walkway from Battery Freeman (Figure 4.2). The test pits were located behind the site of Battery Freeman in order to determine whether or not any early (pre-1900) occupation surfaces still remained. A backhoe trench was dug parallel (east side) to the original drawbridge entry over the ditch.

To obtain a representative sample of the interior of the earthwork, test units were aligned in a cartesian grid using an existing benchmark in Old Fort Stevens called "Gun" as the datum point (N200/E200) (Figure 4.1). This method, in addition to remote sensing techniques, allowed us to identify the location of Battery Freeman, to sample the interior portal of the sallyport, and to define the position and content of the ditch. Figure 4.2 illustrates the position of the test pits relative to the post-1900 plan of the Fort Stevens earthwork. Note that all but one of the test pits are located behind (south) the former position of Battery Freeman.

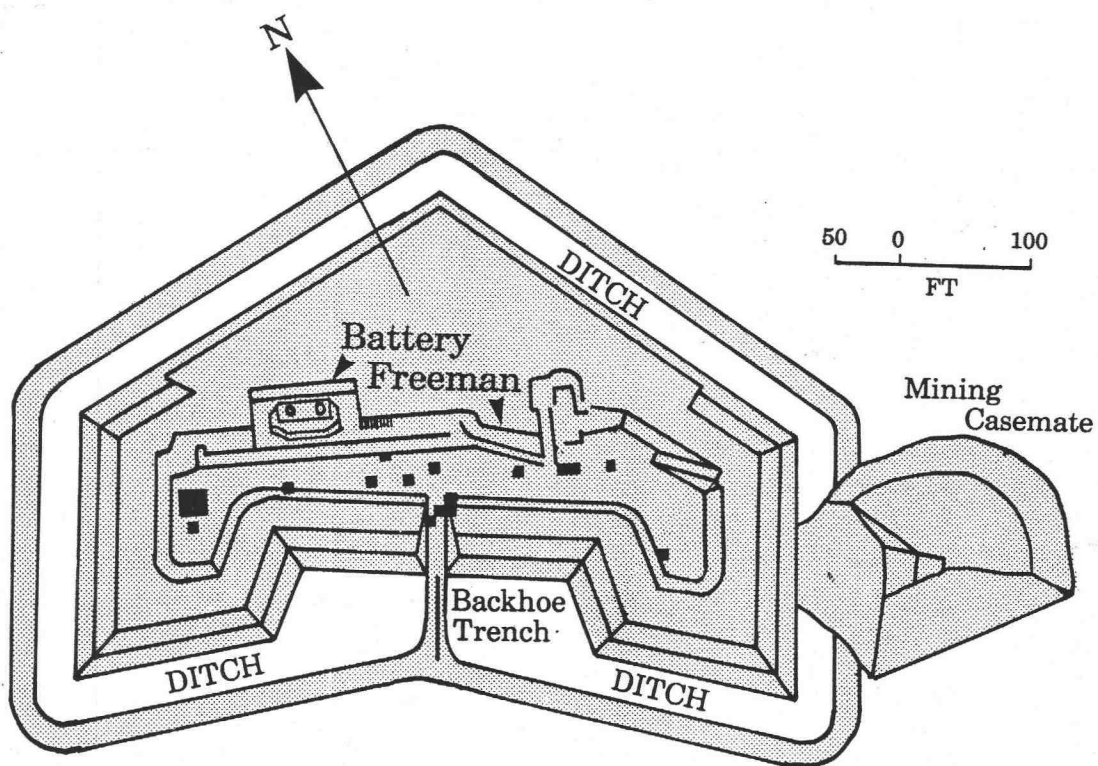
All but one (2x1 meter unit) of the test units were 2x2 meters square. Each test unit was excavated in arbitrary 10 centimeter levels and attempts were made



**FIGURE 4.1.** Location map of test pits within the old earthworks during the 1989 excavation.



(A)



(B)

**FIGURE 4.2.** (A) Oblique aerial photograph showing outline of former earthworks and location of test pits and backhoe trench. (B) Location of tests pits and backhoe trench with respect to floor plan of old earthworks and Battery Freeman.





**FIGURE 4.3.** Photographs of 1989 excavation at Fort Stevens in progress.

to map all cultural materials *in situ*. However, we discovered that the upper 1 meter of sediment across the entire site was fill material resulting from the 1940 destruction and leveling of the earthwork. We then collected all cultural material in the fill unit by 1x1 meter quads within each 10 centimeter level per 2 meter test pit. Once we reached the well-defined Battery Freeman occupation surface below the fill unit, we again began to map the exact position of all cultural debris.

All of the sediments were dry screened through 1/4 inch-mesh hardware cloth. However, we occasionally screened the sediments through 1/8 inch-mesh hardware cloth to see if finer materials were present and discovered that few were.

Using remote sensing techniques, we were able to establish the location of the former ditch (Bell, 1989). Approximately four square meters of the ditch was also sampled to determine whether or not there was intact cultural material below the Battery Freeman fill. However, our efforts to cut a backhoe trench across the ditch east of the entryway failed because the ditch was filled with unconsolidated sand. The geology of the area (acreted sand and high water table) also contributed to the side-walls collapsing and water quickly filling in the pit. The Army National Guard construction unit based out of nearby Camp Rilea helped to remove large pieces of Battery Freeman concrete which enabled us to obtain samples below the fill. With the aid of two large sump pumps, we were able to excavate about 2 meters below the water table. All of the sediments removed from the ditch below the water table were water screened through 1/4 inch-mesh hardware cloth. Because the excavations below the water table were not systematic, the moat unit will not be discussed in great detail.

A field laboratory was established on site to ensure rapid processing and stabilization of the artifacts. What we were unable to clean and catalogue in the field laboratory we completed in the laboratory at Oregon State University. A

significant portion of this thesis entailed classifying the artifacts and their subsequent analyses.

## CHAPTER 5

### ARCHITECTURE, ARCHIVAL INFORMATION, AND DESCRIPTIVE ARCHAEOLOGY OF BATTERY FREEMAN

During the 1989 field season, approximately 102 square meters of the original interior of Old Fort Stevens were sampled. We located five construction features within the interior: a brick double oven; a sump associated with Battery Freeman; an intact portion of the concrete floor of Battery Freeman; a portion of the interior sallyport bulkhead associated with Old Fort Stevens; and an intact portion of the interior scarp wall associated with the pre-Battery Freeman ditch.

In addition to these features, we recovered 4,854 artifacts, of which approximately 94 percent are associated with the Battery Freeman period. The upper 1 meter of the entire test area (hereafter referred to as the fill component) contained a mixture of cultural materials from at least two time periods (the Old Fort Stevens phase [pre-1900s] and the Battery Freeman phase [1900-1940]). Artifacts were thus grouped as belonging to the Battery Freeman period since we could not always determine whether an artifact belonged to the pre-abandonment period or the post-abandonment period.

Three of the five features that were mentioned above, in addition to the fill component, will be discussed under the following four assemblages:

- 1). Fill Component - *ca.* 1900-1940
- 2). Incinerator feature
- 3). Battery Freeman Floor
- 4). Bulkhead wall - pre-Freeman

Since approximately 94 percent of the artifacts are associated with Battery Freeman (*ca.* 1900-1940), it is important to note that the scope of this study focuses

primarily on this phase. Cultural material that pre-dates or post-dates this time period will therefore not be discussed in great detail.

This chapter provides: (1) a description of Battery Freeman architecture, (2) classifies artifacts based on Sprague's (1980) classification scheme and discusses them (where possible) within their functional framework (Appendix A), (3) describes the main stratigraphic features, (4) evaluates the four assemblages, and (5) discusses possible daily activities during the Battery Freeman phase.

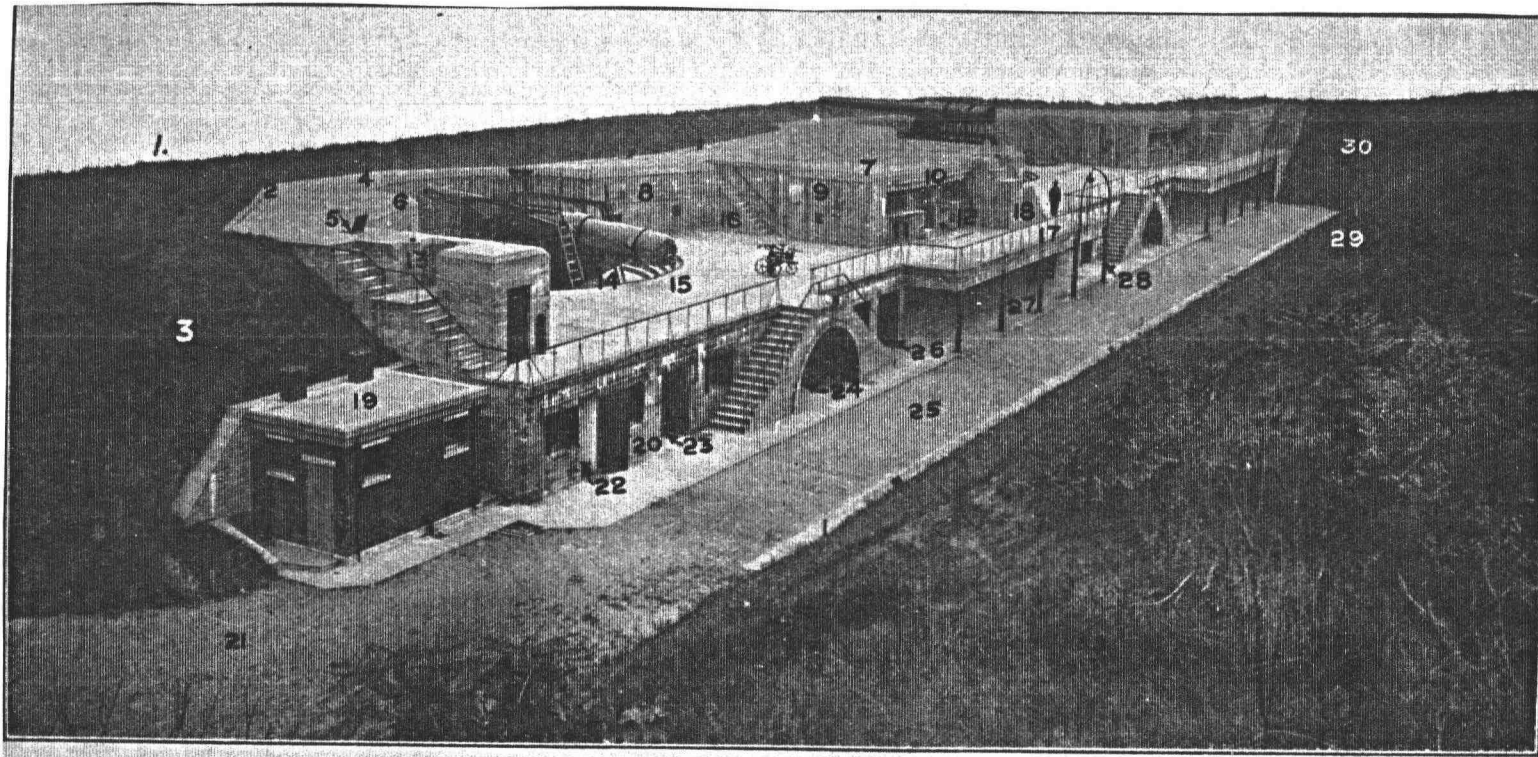
### *Battery Freeman Architecture*

Battery Freeman was one of six batteries constructed between 1895 and 1900 in efforts to replace the obsolete armament of Old Fort Stevens with modern rapid fire guns (OHS 1899, Reel 83, Box 23, Book 13, 1902, Reel 84, Box 23, Book 17). Battery Freeman, however, was the only structure built within the interior of the original earthwork.

Apparently it was not uncommon for new installations to be "physically incorporated into the old forts" (Robinson, 1977:132). Examples of other batteries that were constructed within former forts in the United States include: a battery built in 1898 within the parade ground of Fort Morgan, Mobile Point Alabama; batteries built in 1901 behind the original earth parapets of Fort Gaines, Alabama; and a battery constructed in 1899 in the middle of the parade ground at Fort Sumter, South Carolina (Robinson, 1977; Floyd, 1985).

The batteries constructed at Fort Stevens were quite typical of the coastal batteries constructed during the "Endicott period" (Figure 5.1). Hines and Ward (1910:6) defined a battery as follows:

The entire structure erected for the emplacing, protection and service of one or more guns or mortars, together with the guns and mortars so protected. The guns of a battery are of the same size and power,



### A Seacoast Gun Battery

- |                               |   |                           |                                |
|-------------------------------|---|---------------------------|--------------------------------|
| 1. Exterior Slope of Parapet. | 9. Traverse Wall.                       | 16. Platform Stairs.      | 24. To Magazine.               |
| 2. Superior Slope of Parapet. | 10. Canopy.                             | 17. Corridor.             | 25. Battery Parade.            |
| 3. Interior Slope of Parapet. | 11. Reserve Table.                      | 18. Corridor Wall.        | 26. Office.                    |
| 4. Blast Slope or Apron.      | 12. Delivery Table.                     | 19. Latrine.              | 27. Gallery.                   |
| 5. Magazine Ventilator.       | 13. Observing Station<br>(Crow's Nest). | 20. Parade Wall.          | 28. Crane.                     |
| 6. Interior Crest.            | 14. Gun Platform.                       | 21. Approach.             | 29. Interior Slope of Parados. |
| 7. Traverse.                  | 15. Loading Platform.                   | 22. To Oil and Tool Room. | 30. Traverse Slope of Parados. |
| 8. Interior Wall.             |   |                           |                                |

FIGURE 5.1. A seacoast battery with major architectural features identified (from Hines and Ward, 1910).

and are grouped with the object of concentrating their fire on a single target and of their being commanded directly by a single individual. Normally a battery of the primary armament consists of two guns or two pits of mortars. Under exceptional circumstances a single gun with its fire-control service may constitute a battery.

### *Archival Information*

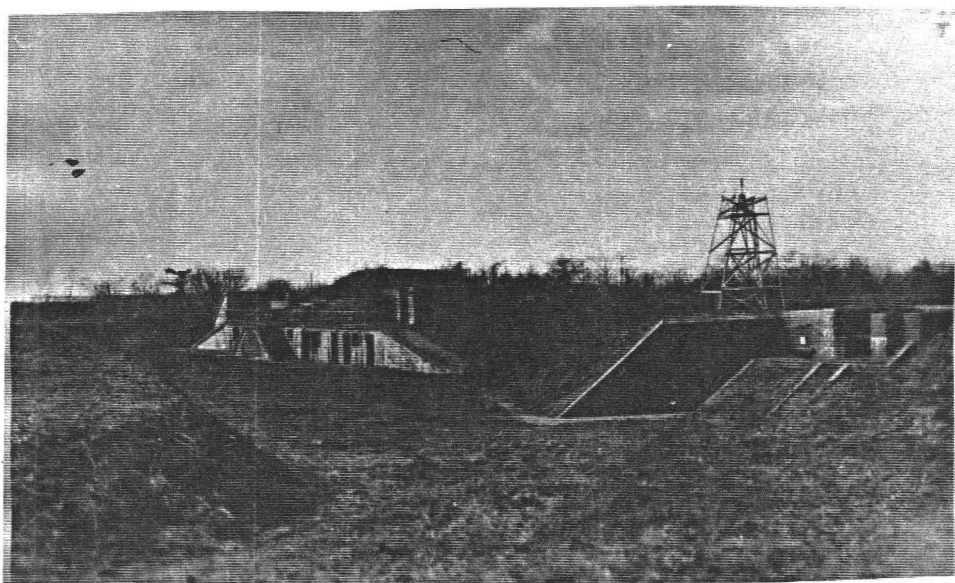
Although the Battery Freeman structure no longer exists, significant architectural information on the structure can be obtained from archival data and comparison to existing batteries from Fort Stevens that were contemporary with Battery Freeman.

The batteries on the site of Fort Stevens were made of concrete, with parapet walls covering the entire facade which faced outward toward the Columbia River. The rears of the batteries, which face the interior of the fortification, exhibit visible architectural details such as doors and windows. Photographs of the rear of Battery Freeman illustrate some of the architectural features associated with its construction (Figure 5.2).

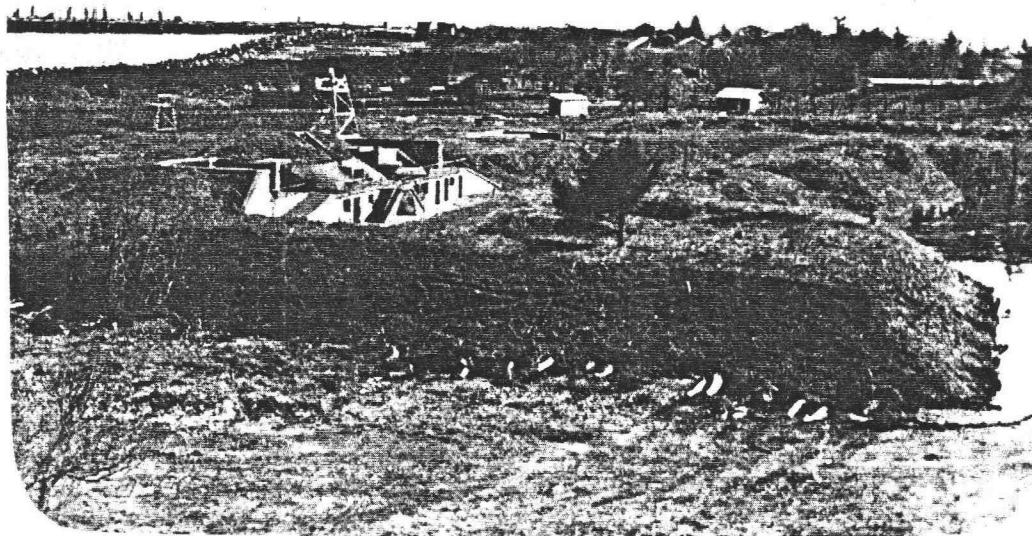
There are only a few photographs of Battery Freeman, and these provide sufficient detail only to ascertain that it had two levels and several doors and windows. The photographs of Battery Freeman show that the structure had six exterior doors, five windows, and two stairways (facing each other) leading to the second floor just outside of the battery (Figure 5.2).

More general information on architectural design and function can be clearly identified in these photographs. They show that Battery Freeman was built on the left (west) side of the earthwork's interior to support two six-inch rifles on Barbette pedestal carriages (Figure 5.3) and one three-inch gun on a pedestal mount. The guns of the batteries were "on line with the 15 pounder-installation which was 190





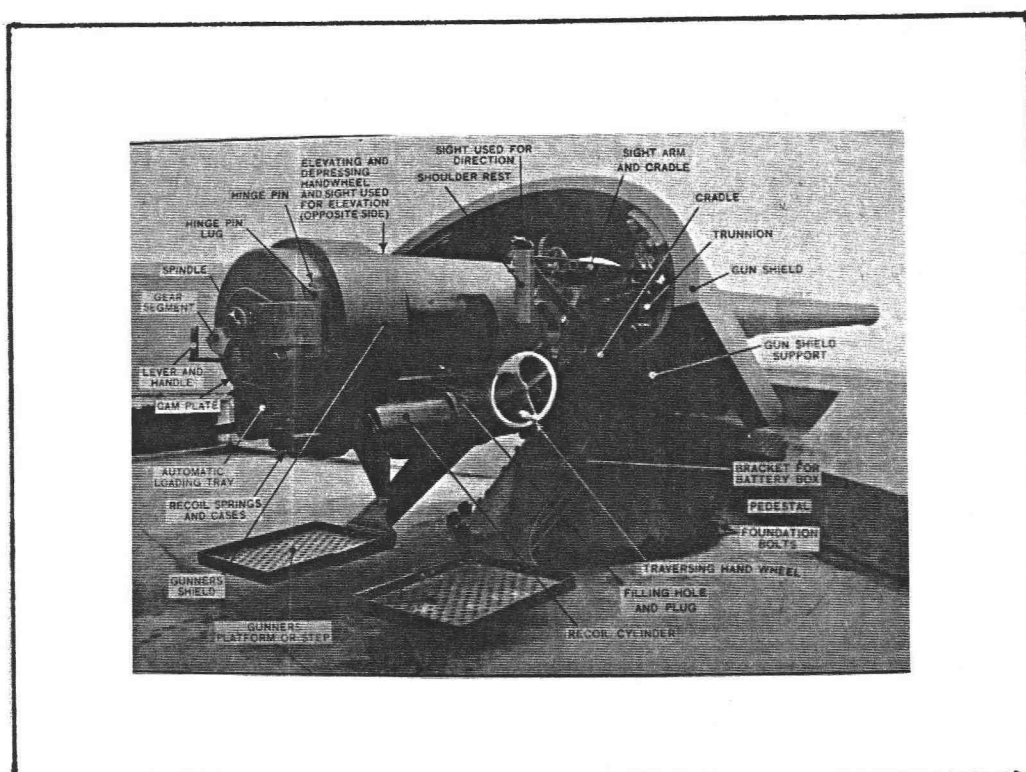
(A)



(B)

**FIGURE 5.2.** Photographs of the rear of Battery Freeman showing architectural features associated with its construction. (A) 1938 photograph looking northwest (from Fort Stevens Museum collection). (B) View looking toward northeast (from Hanft, 1980).





**FIGURE 5.3.** Example of a 6" gun mounted on a Barbette carriage (from Hines and Ward, 1910).

feet to the right of the No. 1 six-inch rifle. The bearing of the guns-angle line was South 70 degrees East" (Hanft, 1980:164).

Additional information was obtained from a blueprint of the emplacement (Figure 5.4) that shows the dimensions of Battery Freeman as *ca.* 139 feet long and 34 feet wide. The surface of the concrete floor of the rear section occurs at the 15.67 msl elevation. The blue print also illustrates the floor plan of the battery as having the following rooms on the first floor: a powder magazine (11'6" x 30'8"), two shell rooms (each 15' x 10') which ran front to rear with the powder magazine extended lengthwise between them; a lobby; a guard room; two storage rooms; a latrine; and an observation room (OHS; Hanft, 1980). There was also an "electric light plant" on the lower level. The entire structure was bombproofed, "a term applied to military structures of such immense thickness and strength that shells cannot penetrate them" (Hines and Gates, 1910:9). The drains in the battery were connected to a main 6-inch sewer line that emptied into the ditch surrounding the old earthworks (Hanft, 1980). Water level in the ditch was regulated by a drain which led to a 12-inch sewer emptying into the Columbia River.

Although the artifacts that we recovered from the Battery Freeman phase were not *in situ*, the function of a number of them can be inferred from various lines of evidence provided by the use of archival data. The documents on file at the National Archives branch in Seattle proved to be an invaluable resource, particularly for information on the construction of Battery Freeman. These constructional data are based on several of the bi-weekly reports of progress to Captain W.C. Langfitt, Corps of Engineers, from assistant engineer Gustave Hegardt.

October 2, 1901:

427 cubic yards of concrete were laid...the gun platforms, rear stairway...nearly completed. The telephone booths, powder recess...were also completed. Hollow tiling is being places alongside the walls...(NA, Box 467, Book 3:335)

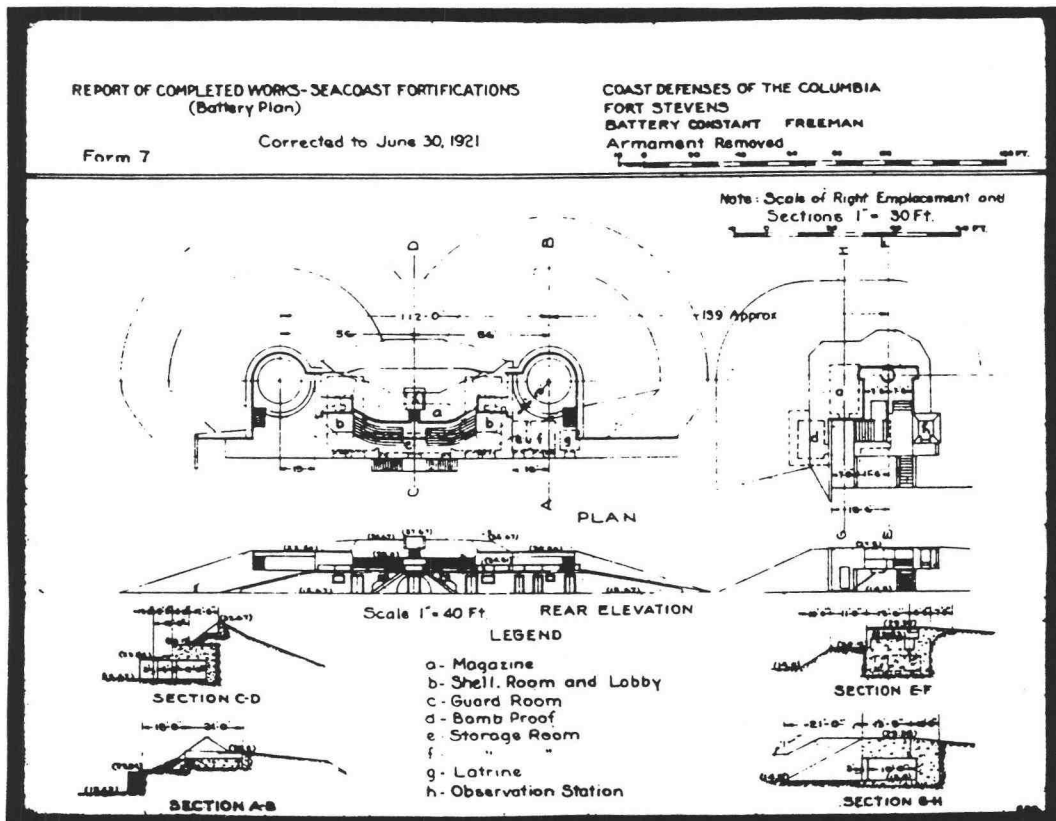


FIGURE 5.4. Architectural designs of Battery Freeman (from Hanft, 1980).

October 11, 1901:

all platform work, steps and stairways are completed, including asphalt in the joints and washing of inside walls are underway...nearly all the iron doors and shutters have been made (NA, Box 467, Book 3:343)

October 22, 1901:

The work remaining to be done is the finishing of the terreplein concrete sidewalk and the concrete sidewalk leading from the six-inch to the 15-pdr emplacement. The ramp concrete walks were finished (NA, Box 467, Book 3:357)

November 1, 1901:

All terreplein and ramp concrete walks, and the concrete walk...have been completed. The outside concrete surfaces have been treated to two coats of cement and waterproofing wash...The finishing of the floors in the rooms has begun. The driven well to supply water to the emplacements in the old fort has been put in and connected up with the hand as well as the electric pump.

The work remaining to be done...finishing of the floors; the laying of the sewer to connection with 15-pdr.; the white washing of walls and ceilings; the purchase and installation of chain ammunition hoists; installation of the electric-light plant; the loaming and sodding of the parapet; the grading and cleaning up in rear of battery; and the hanging of doors and shutters (NA, Box 467, Book 3:365-366).

\* also mentions a letter to Western Electric Co. re: 46 broken glass jars and 51 good. What kind of jars were these and what were they used for? Can we see fragments of these in the archaeological record?

November 11, 1901:

The loaming and sodding of the parapet was completed, together with all slopes at the ramps...floors were finished in the latrine, storage battery and switchboard rooms; the magazine and shell room and lobby...all walls and ceilings were given two coats of zinolith wash. The hanging of doors was begun and the windows are being painted...about two-thirds of the trenches for the lead cables to be laid to Central Electric Station and the 15-pdr emplacement have been dug (NA, Box 467, Book 3:371).

December 3, 1901:

The installation of the storage battery and the wiring of the emplacements was begun. The necessary changes were made to the Central Station switchboard, lightning arresters put in, and all lead cables, connecting these two emplacements with the Central Station...laid under ground, in carboleneumized cedar boxes, for pick and shovel protection...The wiring of the emplacements was completed...(NA, Box 467, Book 3:391)

December 11, 1901:

The folding gates for magazine and the emplacement entrance doors

were set...all painting of doors and shutters completed. All rubbish has been removed from the grounds...The wiring of the emplacements...is completed, and the storage battery is being connected up ready to receive its initial charge (NA, Box 467, Book 3:398).

December 23, 1901:

The storage battery was charged three times and "holds up" better than any of the others, when first put in commission. All dimmers and instruments tested and working satisfactorily (NA, Box 467, Book 3:405).

December 23, 1901:

The following list of property to be turned over to the Artillery with the the two emplacements for 6-inch guns in old Fort Stevens...(NA, Box 467, Book 3:407).

- 2 Ammeters, Weston's
- 1 Bracket, gooseneck, with shade
- 1 Circuit Breaker, I.T.E.
- 1 Charging Resistance
- 3 Dimmers
- 1 Hydrometer
- 25 Lamps, incandescent, 16 c.p.
- 21 Lampguards
- 8 Lightning Arresters
- 1 Lamp Holder, portable
- 1 Lewis-automatic cut-out
- 8 Mouthpieces for speaking tubes
- 21 padlocks
- 1 Pump, hand, Cook's Well
- 1 Pump, electric, 1-2 H.P., #43677, with starting rheostat #58887
- 1 Switchboard
- 1 Syringe, battery

January 2, 1901:

The folding gates for magazine and emplacement doors were hung...all painting of doors and shutters completed. The emplacements were wired for electric-lights, switchboard finished and storage battery installed and charged. All instruments, dimmers, etc., were tested and the plant works satisfactorily in every way.

Detailed drawings of drainage, water supply and electric systems have been furnished...(NA, Box 467, Book 3:416).

January 23, 1902:

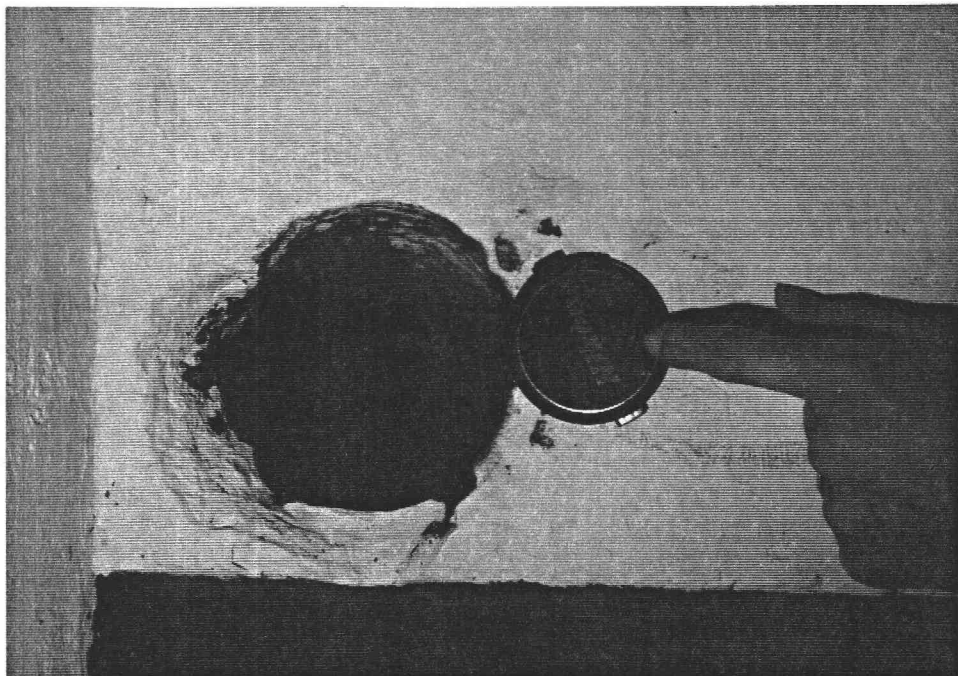
Re: Two emplacements for six-inch guns, on pedestal mounts - in Old Fort Stevens:

These were turned over to the Artillery on the 17th and on this date the watchman was discharged (NA, Box 467, Book 3:431).

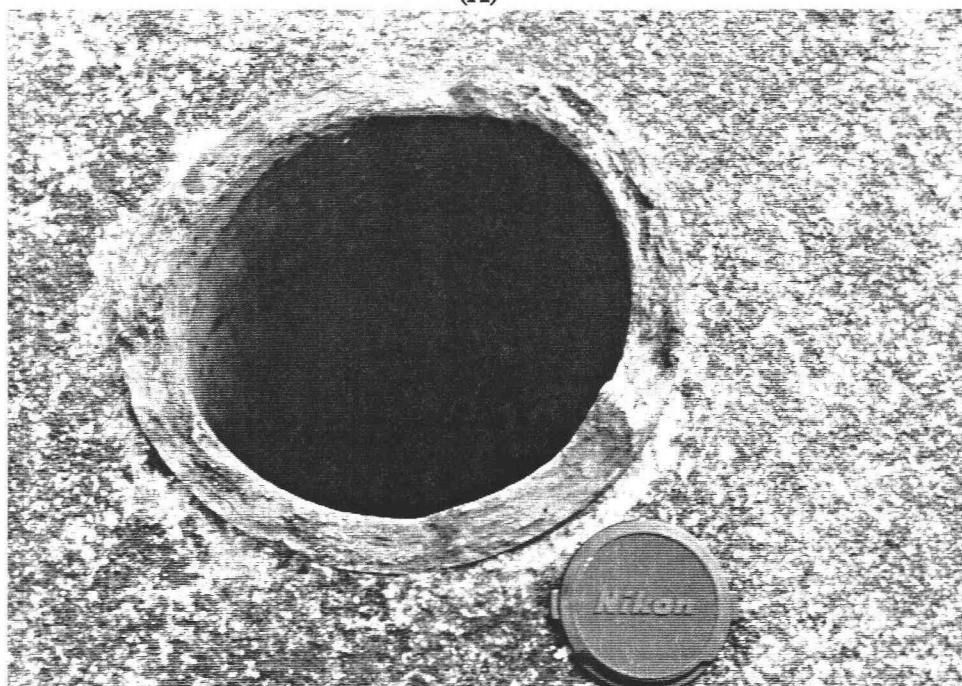
### *Comparative Methods*

Other batteries in Fort Stevens that were built at nearly the same time and with similar materials include Smur, Clark, Lewis and Pratt. Unlike Battery Freeman, however, the others still stand today (Figure 3.4). As a result, these batteries are critical resources for assessing the function of the artifacts from Battery Freeman, especially for those classified as architectural items. By examining these extant structures we can more clearly identify architectural features of the former Battery Freeman structure and identify the function of many artifacts for which information is lacking. A comparative study permits a more accurate classification of an artifact based on its intrinsic characteristics; otherwise, the function of an artifact would be more difficult to determine. Close attention to the use of architectural materials in existing structures provides clues to the function and context of an artifact.

Observations of Battery Pratt provided significant information as to the function of some of the larger artifacts such as I-beams and metal doors that were recovered from the ditch. By examining the ceramic pipes that run through Battery Pratt, for example, we can say that the glazed tile fragments that were unearthed from Battery Freeman were not for drains but instead were used for air ventilation or conduits for electrical wiring (Figure 5.5) (e.g., Hanft, 1980:215). Examples of other functions of artifacts from Battery Freeman inferred by functional comparison with Battery Pratt include: iron I-beams situated between floor joints mainly to support the upper level; iron curved beams used for ammunition trolleys (Figure 5.6); several types of metal fasteners used to keep electrical wiring fastened to the wall or ceiling (Figure 5.7); metal wire (0.5-1.0" diameter) ranging from five to nine feet with an "eye" at the end used for fasteners; wooden interior doors; iron bars around the windows; and metal exterior doors.



(A)

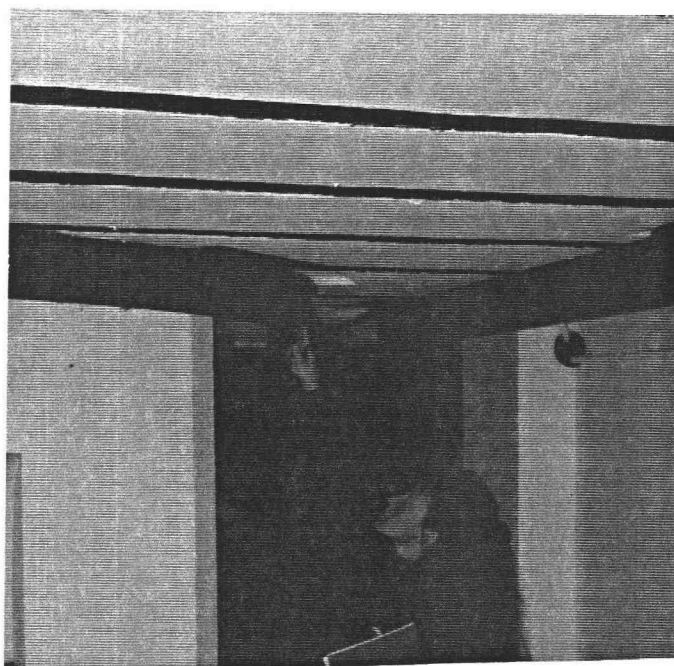


(B)

**Figure 5.5.** (A) Six inch ceramic pipe in Battery Pratt that was used for ventilation of shellrooms, guardroom, and latrines, as well as for access for electric wiring. (B) Eight inch ceramic pipe arising at top of Battery Pratt used for ventilation of magazines.



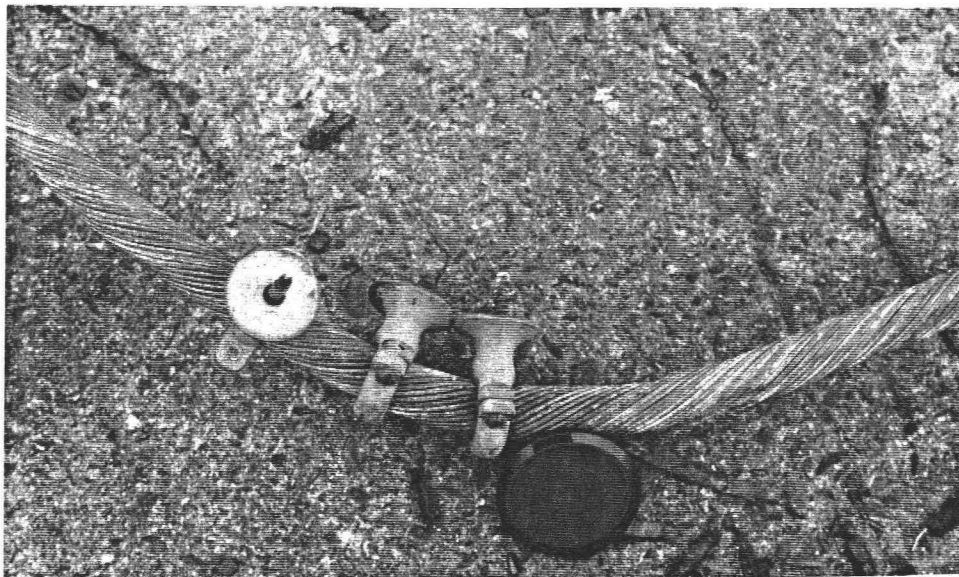
(A)



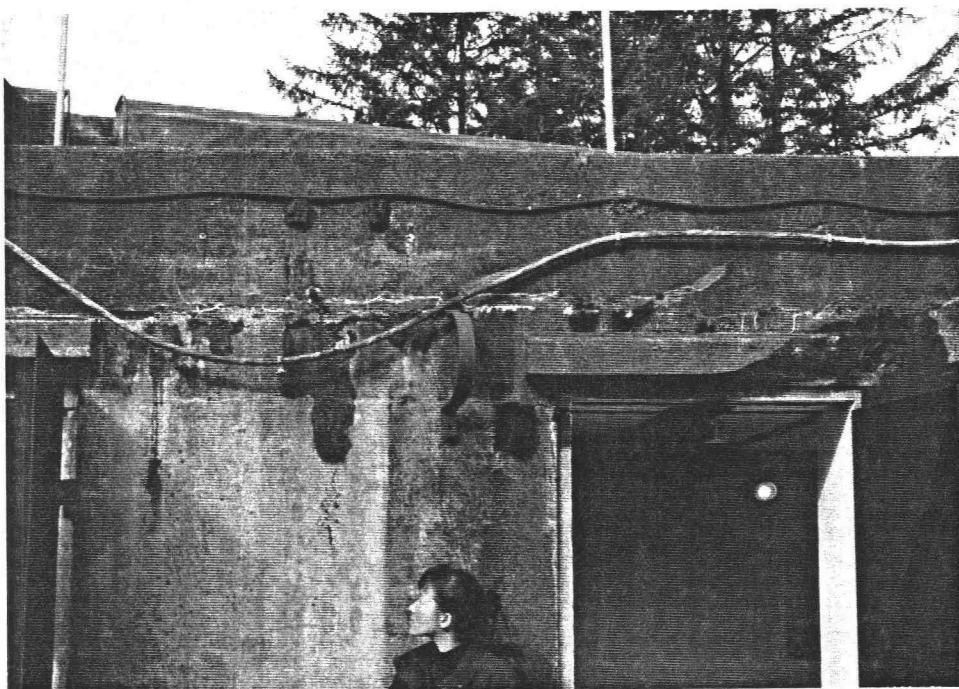
(B)

**FIGURE 5.6.** (A) Curved metal I-beam with one flange (left side) wider than the other and holes at the ends. Recovered from the ditch. (B) Curved metal I-beam from Battery Pratt with the same characteristics and dimensions as in (A). Their function was to support ammunition trolleys.





(A)



(B)

**FIGURE 5.7.** (A) Steel cable with metal fasteners recovered from the ditch. (B) Steel cable supported along concrete walls of Battery Pratt by metal fasteners.

### *Artifacts*

Sprague's (1980) functional classification system was used to identify, categorize, and quantify the 4,854 artifacts (Table 5.1). This system was initially designed for the analysis of dating nineteenth and twentieth century artifacts based on the premise that in order to place an artifact in its proper category, it is necessary to consider the object's function and its relationship to other artifacts. Each artifact is placed under a certain functional category and described in the context of that category.

Within the framework of Sprague's classification scheme, the artifacts recovered from the 1989 excavation of Old Fort Stevens were subdivided into three categories:

1. The primary level represents the context of utilization.
2. The secondary level reflects the type of activity or use of which an artifact was applied.
3. The tertiary level is subdivided into type, class and/or variety depending on the artifact category.

The following example illustrates the classification system according to category, type, and subtype:

**Architecture**  
*Nails*  
 Machine-cut square nails

The artifacts were categorized into the following seven functional groups: personal items, domestic items, architecture, commerce and industry, transportation, group services, and unknowns. Table 5.1 provides a listing of the artifacts recovered from the 1989 excavation. As shown in Table 5.2, the majority of the artifacts are associated with architecture and domestic items. However, it must be emphasized that although many artifacts make up only a small percentage of the total number

TABLE 5.1

## ARTIFACTS RECOVERED DURING THE 1989 FIELD SEASON

Personal Items	N SAMPLE INTERIOR/DITCH	
<i>Clothing</i>		
Cloth Fragment	8	
Oil Cloth Fragment	1	
Button, Diamond Brand	1	
Button, Decorative, Brass	1	
Button, Metal, 4 Hole Plain, Corroded	1	
Cloth Rivet, Brass	1	
Suspender Buckles	2	
Belt or Strap Buckle	1	
<i>Coins</i>		
Indian Head Penny, Copper, US, 1903	1	
<i>Footware</i>		
Heal Fragment	1	
Eyelet	1	
<i>Grooming</i>		
Comb Fragment	1	
<i>Indulgences</i>		
Clay Pipe Stem Fragment, White	1	
<i>Pocket tools and accessories</i>		
Pocket Watch, Brass, Maker Unknown	1	
<i>Recreation</i>		
Golf Balls	3	
Marbles, Glass	1	
<b>Domestic Items</b>		
<i>Containers, Glass</i>		
Clear Glass, Bottles	1	5
Clear Glass, Body Fragments	842	192
Clear Glass, Base Fragments	18	2
Clear Glass, Neck Fragments	27	3
Clear Glass, Melted	24	
Amber Glass, Bottles	2	3
Amber Glass, Neck Fragments	6	
Amber Glass, Body Fragments	113	12
Aqua Glass, Body Fragments	128	24
Green Glass Bottle		2
Green Glass, Body Fragments	62	

TABLE 5.1 (CONTINUED)

Green Glass, Base Fragments	1	
Dark Green Glass, Body Fragments	6	
Pink Glass, Body Fragments	13	
Purple Glass, Body Fragments	1	
Cobalt Blue Glass, Neck Fragment	1	
Milk Glass Jar Fragments	2	
<i>Container Tops</i>		
Plastic Bottle Caps, Male Threads	2	
Plastic Bottle Cap, Screw Threads	1	
Crown Cap	1	
Large Metal Screw Cap	1	
Large Ceramic Stopper	1	
Large Brass Container Top	1	
<i>Bottle Opener</i>	1	
<i>Brass Box Latch</i>	1	
<i>Ceramic Flatware and Hollow Ware</i>		
White Earthenware Fragments	11	
Earthenware with Blue Transfere Print	2	
Porcelain Fragments, White/Clear Glaze	7	
Porcelain Fragments, White/Light Green	2	
<i>Bed or Cot Spring</i>	1	
<i>Small Spring Fragment</i>	2	
<i>Stove Parts</i>		
Circular Stove Top Lid		1
Stove Pipe Fragment	1	
Mica Sheet Fragment	3	
<i>Light Bulb</i>		
Interior Parts	5	
Bulb Glass	2	
Brass Bulb Base	1	
<i>Battery</i>		
D Cell, Fragmented	1	
<i>Keys</i>		
Skeleton Keys	3	
Brass Key	1	

TABLE 5.1 (CONTINUED)

## Architecture

<i>Nails</i>		
Machine Cut Square Nails		308
Square Nail Fragments		265
Brass Square Nail, Hand-Wrought		1
Wire-drawn Nails		98
Wire-drawn Nail Fragments		87
Unidentifiable Nail Fragments		43
<i>Fence Staples</i>		4
<i>Large Fence Staples with Metal Ring</i>		1
<i>Wood Screws</i>		
Iron (flat head)		15
Brass (round head)		2
<i>Wood Screw with Washer</i>		2
<i>Washers</i>		11
<i>Bolts</i>		4
<i>Nuts</i>		
Hexagonal Head		6
Square Head		4
<i>Bolt with Nut</i>		6
<i>Bolt with Nut and Washer</i>		2
<i>Iron Drift Pin</i>		2
<i>Rivet Heads, Iron</i>		8
<i>Spring Loaded Hinge</i>		2
<i>Triangular Door Hinge</i>		1
<i>2" Iron Pipe and Elbow</i>		1
<i>1" Iron Pipe Fragment</i>		1
<i>3/4" Lead Pipe Fragment</i>		1
<i>1/2" Lead Pipe Fragment</i>		1
<i>Lead Latch Fragment</i>		1

TABLE 5.1 (CONTINUED)

<i>Expandable Lead Hanging Bracket</i>	2	
<i>Lead Bracket Fragmented</i>	2	
<i>Sheet Lead Fragments</i>	50	
<i>Electrical Fuse, Brass End Fragment</i>	1	
<i>Electrical Wire, Insulated</i>	2	
<i>Copper Electrical Wire with Terminal</i>	1	
<i>Electrical Wire Fragments, Uninsulated</i>	51	
<i>Porcelain Insulators</i>		
Three Wire Cleats	1	
Wire Cleat Fragments	2	
Split Insulator Fragment	1	
Unidentifiable Fragments	4	
<i>Porcelain Switch Plate</i>		
Bryant 2 amp	1	
<i>Glass Insulator, Aqua, Brookfield</i>	1	
<i>Flat Glass, Clear</i>	64	
<i>Orange Flat Clay Tile Fragments</i>	196	2
<i>Red Clay Drain Tile Fragments</i>	42	3
<i>Bricks and Brick Fragments</i>	298	2
<i>Mortar Samples</i>	10	
<i>Concrete Samples</i>	69	
<i>Slate Fragments</i>	40	1
<i>Linoleum Fragments</i>		16
<i>Red Paint Fragments</i>	5	
<i>Glass Tubing</i>	165	14
<b>Commerce and Industry</b>		
<i>Blacksmithing</i>		
Clinkers	583	

TABLE 5.1 (CONTINUED)

<i>Expandable Lead Hanging Bracket</i>	2	
<i>Lead Bracket Fragmented</i>	2	
<i>Sheet Lead Fragments</i>	50	
<i>Electrical Fuse, Brass End Fragment</i>	1	
<i>Electrical Wire, Insulated</i>	2	
<i>Copper Electrical Wire with Terminal</i>	1	
<i>Electrical Wire Fragments, Uninsulated</i>	51	
<i>Porcelain Insulators</i>		
Three Wire Cleats	1	
Wire Cleat Fragments	2	
Split Insulator Fragment	1	
Unidentifiable Fragments	4	
<i>Porcelain Switch Plate</i>		
Bryant 2 amp	1	
<i>Glass Insulator, Aqua, Brookfield</i>	1	
<i>Flat Glass, Clear</i>	64	
<i>Orange Flat Clay Tile Fragments</i>	196	2
<i>Red Clay Drain Tile Fragments</i>	42	3
<i>Bricks and Brick Fragments</i>	298	2
<i>Mortar Samples</i>	10	
<i>Concrete Samples</i>	69	
<i>Slate Fragments</i>	40	1
<i>Linoleum Fragments</i>		16
<i>Red Paint Fragments</i>	5	
<i>Glass Tubing</i>	165	14
<b>Commerce and Industry</b>		
<i>Blacksmithing</i>		
Clinkers	583	

TABLE 5.1 (CONTINUED)

Coal	3	1
<b>Transportation</b>		
<i>Horseshoe</i>	1	
<i>Railroad Spike</i>	2	
<i>Spark Plug, Ceramic Top</i>	1	
<i>Tire Thread (plaster cast)</i>	1	
<b>Group Services</b>		
<i>Ammunition</i>		
Lead Slug, .22 cal.	7	
Steel-jacketed Slug, .45 cal.	8	
"Minie Ball", .50 cal.	2	
Bullet, Complete, .22 short, H backstamp	1	
Cartridge, .22 cal., short, H backstamp	3	
Cartridge, .22 cal., short, US backstamp	2	
Cartridge, .22 cal., short, U backstamp	1	
Cartridge, .22 cal., long, corroded base	1	
Cartridge, .44 cal., rimfire-H backstamp	1	
Cartridge, .45 cal., REM-UMC 18 backstamp	3	
Cartridge, .30 cal., FA Backstamp	9	2
Cartridge, .30 cal., U M C	2	
Cartridge, .30 cal., U S C CO backstamp	1	
Cartridge, .30 cal., Dummy, F A backstamp		1
Paper Wadding from .30 cal. cartridge	1	
Berdan Primer		2
Primer, Type Unknown, Large		1
Cannon Friction Primer, Complete		2
Cannon Friction Primer, Brass Tube	5	4
Cannon Friction Primer, Brass Pin	23	1
Clip Fragments for .30 cal. cartridges	5	
<i>Gun Parts</i>		
Front Pintle Mount Cannon	1	
<i>Cartridge Feeding Device</i>		
Brass Flange with Female Threads		1
<i>Insignia</i>		
Crossed Cannon Hat Insignia		1
Brass Collar Pin	1	



TABLE 5.1 (CONTINUED)

<i>Buttons</i>		
Brass Uniform, Plain Shield, Waterbury Button Co. 4 hole metal, ARMY backstamp	1	1
<b>Unknowns</b>		
<i>Chrome Half Rings</i>	2	
<i>Small Metal Attachment Rings</i>	2	
<i>Oval Wire Ring Handles</i>	2	
<i>Unidentifiable Lead Fragments</i>	2	
<i>Unidentifiable Sheet Metal Fragments</i>	668	
<i>Paper Fragments, Printed Text</i>	1	
	<b>TOTAL</b>	<b>4854</b>

TABLE 5.2. PERCENT OF ARTIFACTS  
WITHIN SEVEN FUNCTIONAL CATEGORIES

Personal Items	0.5%
Domestic Items	31.8%
Architecture	39.5%
Transportation	0.1%
Commerce and Industry	12.1%
Group Services	2.0%
Unknowns	14.0%
<b>TOTAL</b>	<b>100.0%</b>

recovered, in many cases they may be of much greater interpretative value than those artifacts that make up the majority because of the specific functional and/or temporal information that they provide.

Appendix A provides a detailed description of the artifacts that were recovered from both the interior of the earthworks and the ditch. The Appendix

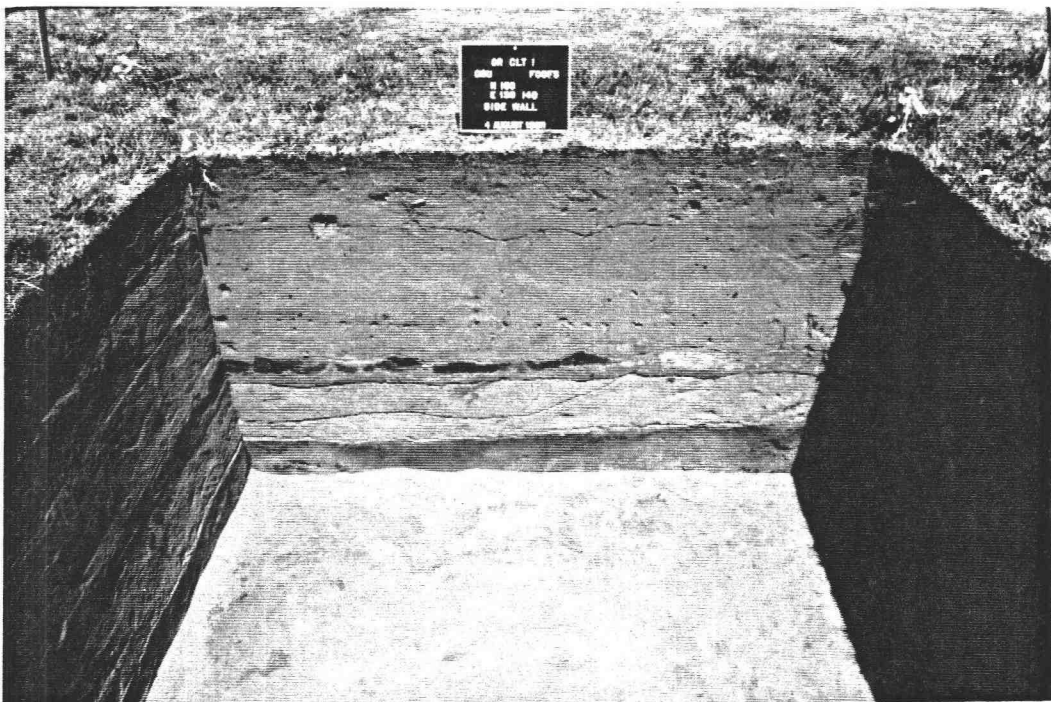
focuses on the description and identification of the form, function, condition, and size of each artifact. In addition, reference to the period and mode of manufacture, material content, and place of origin for certain artifacts are also discussed.

### *Stratigraphic Features*

Plans of the earthwork as it was originally constructed were available to us as was a relatively detailed documentation of modifications made to the structure undertaken between 1864 and 1899 (Sekora, 1989). Several early historic survey benchmarks can still be found at Fort Stevens, so we were able to resurvey and accurately stake the layout of the old earthworks. On this basis, we identified the present ground level as within ca. 10-15 cm above the original elevation of the interior parade ground of Old Fort Stevens. This provided a reference surface (datum) for placing excavations in a stratigraphic context with respect to the original earthworks' surface.

Test excavations in the old parade ground area and in the vicinity of the powder magazine identified a stratigraphic profile that was fairly uniform throughout the site area. The upper 1 to 1.3 meters is characterized by a medium-to coarse grained sandy matrix (Figure 5.8) containing artifacts from the Civil War through World War II (discussed below). This unit is referred to as the fill unit. A sterile sand layer was encountered below the fill unit. A dark, ashy layer composed of burnt, consolidated sand was also observed in this unit, but at varying depths (mostly 60 cm below the surface). This layer indicates that the area may have been burned at one time.

At a depth of 70 cm (level 6/7) in the 2x1 test unit (Unit 12), we encountered the concrete surface of the Battery Freeman floor.



**FIGURE 5.8.** Photograph of typical fill unit sediments, exposed in unit 2.

This information indicates that the ground level inside the earthworks had been lowered by up to 1.3 meters during the construction of Battery Freeman in 1900, thus eliminating all evidence of the previous occupation surface. When the earthworks and Battery Freeman were leveled in 1940, the ground surface was returned to a level (top of fill unit) approximating the Civil War *terra plein* or parade ground elevation. As a consequence, there was no need (in 1940) to remove the floor of Battery Freeman, although the superstructure was blown up and removed, and the associated active surface only needed to be covered by sand from the surrounding parapet walls. The base of the fill unit, at the contact with the underlying sterile sand, thus represents a well-defined Battery Freeman occupation surface at 1 to 1.3 meters.

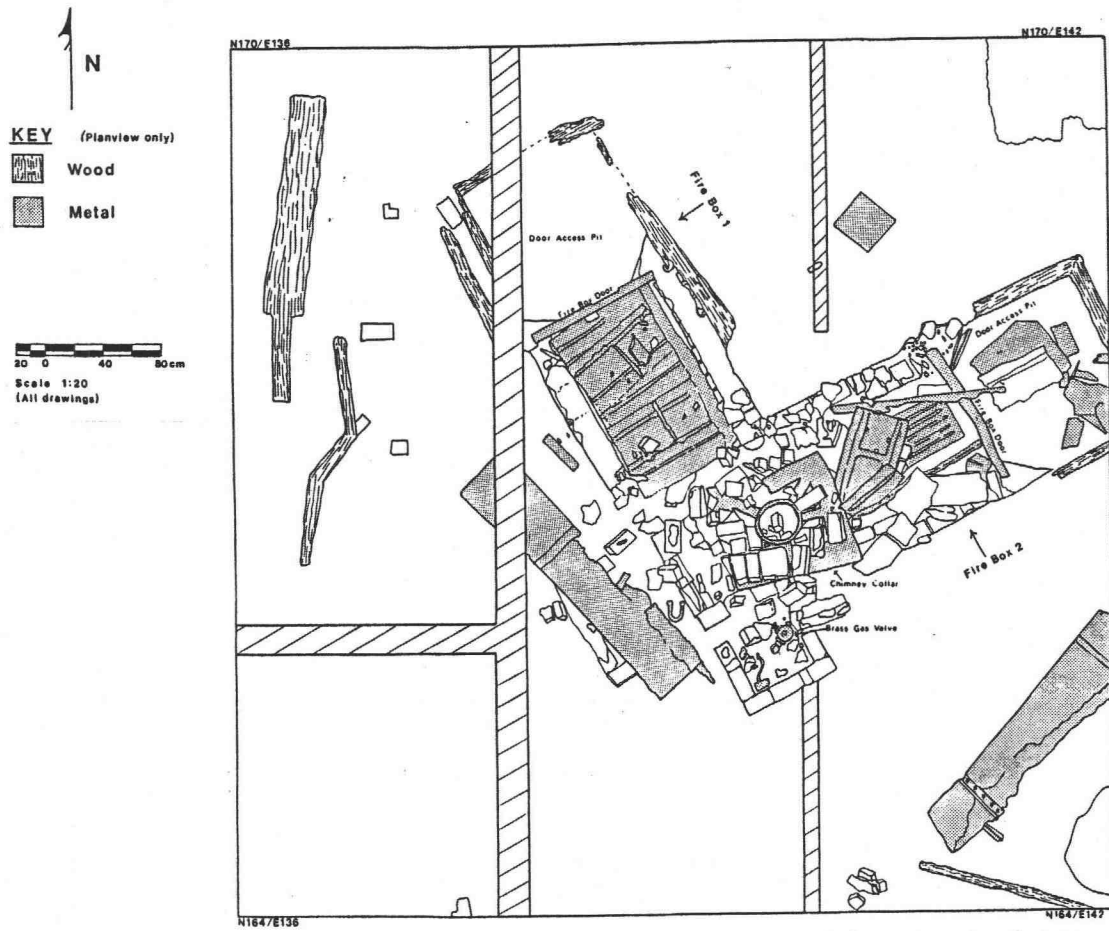
A brick double oven feature, referred to as the "incinerator feature" (Figures 5.9, 5.10), occupied an area equal to nine 2x2 meter grids (Unit 1) beginning at a depth of 70 cm (Figure 4.1). The incinerator feature is located just southwest of the rear of the battery against the west parapet wall (Figure 4.2).

A bulkhead wall of the sallyport entrance was the only pre-1900 structural detail associated with the primary earthworks that we encountered above the water table (Figures 5.11, 5.12). Unit 9, which is equal to four 2x2 meter test pits, revealed the bulkhead wall beginning at a depth of approximately 84 cm below the surface. This remnant of the early earthworks survived only because the modified open entry built in 1900 to accommodate the new battery was located slightly west of the original sallyport location.

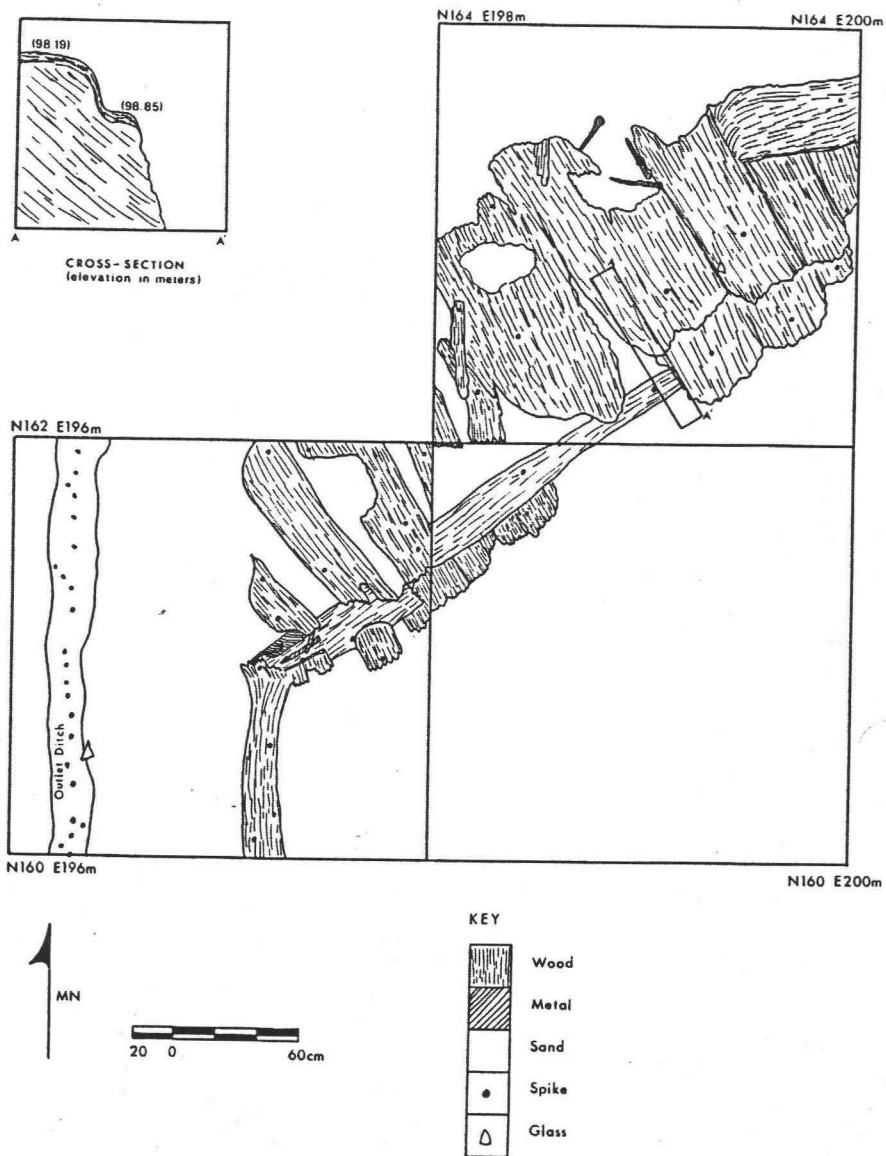
We located the north scarp wall of the ditch surrounding the former earthworks and found it to be perfectly intact below the water table. There is no reason to believe that the entire scarp and counter-scarp walls around the periphery of the ditch are not in a similar well-preserved condition. Instability of the



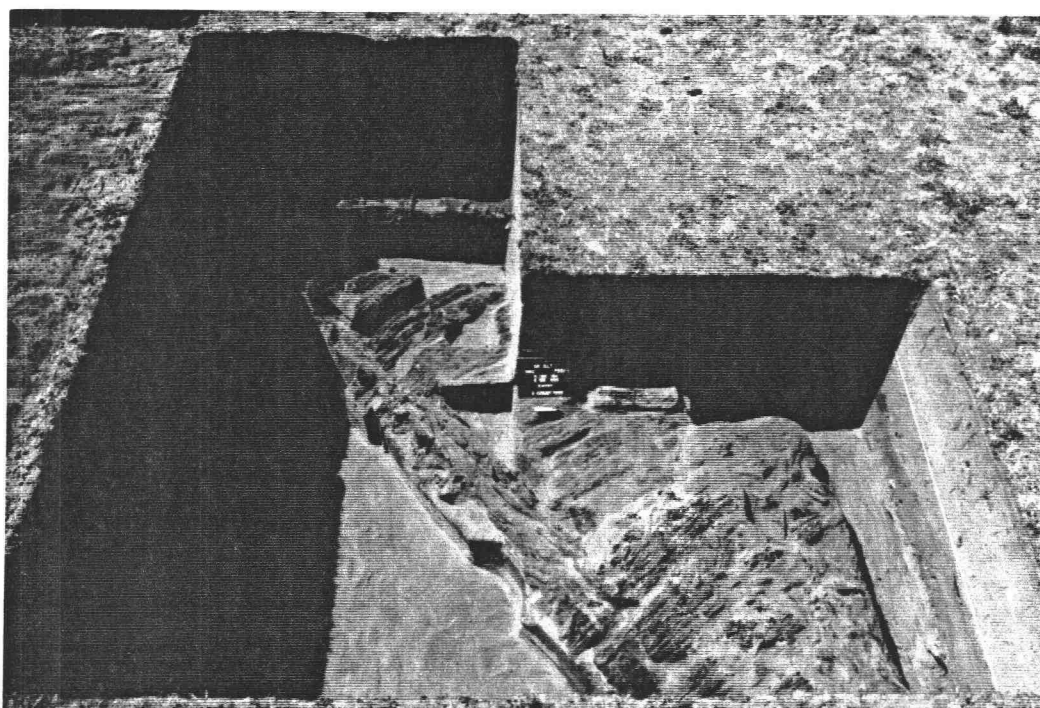
**FIGURE 5.9.** Photograph of the incinerator feature exposed in the 1989 excavation (unit 1).



**FIGURE 5.10.** Map of the incinerator feature exposed in the 1989 excavation (unit 1).



**FIGURE 5.11.** Map showing the bulkhead wall feature exposed in the 1989 excavation (unit 9).



**FIGURE 5.12.** Photograph of the bulkhead wall feature exposed in the 1989 excavation (unit 9).



surrounding sand precluded any further excavation in the ditch, however, and the ultimate depth of the ditch is unknown.

### *Assemblages*

Several assemblages of artifacts can be identified on the basis of their association with recognized stratigraphic features.

#### *Assemblage 1: Fill Component - ca. 1900-1940*

The upper 1 to 1.3 meters of the entire site area, referred to as the fill component, contained artifacts associated mostly with the Battery Freeman phase (ca. 1900-1940); the fill unit contained only an insignificant number of Civil War-era material (two minie balls, several cannon friction primers, and a cannon pintle mount). One possible explanation for the presence of pre-1900 artifacts may be that they were present on the parapet walls and incorporated into the fill component when bulldozed in 1940.

Because the interior of the earthwork was subject to a substantial amount of ground disturbance, most or all of the cultural materials were not in their natural depositional position. Nevertheless, I examined the spatial distribution of the artifacts from the fill unit in order to test for any coherency or patterns; the distribution of the most predominant artifacts, such as ammunition, glass, and tile, are shown in Plate 1 (in pocket).

Most of the artifacts were uniformly distributed within each level of every test unit (Plate 1). Each test pit contained either nails, nail fragments and/or metal objects, and metal fragments. Similarly, glass shards of various colors (colorless, green, blue, and amber) were present in almost all of the pits. Orange clay tile,

either smooth or grooved on one side, and glazed tile were also consistently dispersed.

While not shown in Plate 1, chunks of concrete and mortar were fairly consistent in levels 3 and 4. Analysis of their composition indicates that two types of concrete mixtures were used for the Battery Freeman construction. On the west side of the earthwork interior, a concrete mixture with riverine pebbles and cobbles was predominant, whereas a concrete mixture with angular crushed basaltic gravels was predominant on the east side.

Although cartridge casings and friction primer pins were sporadically distributed, there were two main concentrations of these artifacts. As shown in Plate 1, most of the cartridges were located within Unit 1 (the incinerator feature), whereas the majority of the friction primer pins were located in Unit 9 (the bulkhead feature).

#### *Assemblage 2: Incinerator Feature*

Artifacts associated with the "incinerator feature" (Figures 5.9, 5.10) include: an "L" shaped brick feature with iron doors, chimney, piping, glass shards, various metal objects (ie., nails, wire), cartridges, clinkers, two golf balls, the base of a glass bottle, and a metal patent (11" x 4", in two pieces) for the incinerator with the manufacturer's name and date imprinted as "McCalls Incinerator patented 1905" (Table 5.3).

Thus far, I have found no archival information on an incinerator used at Battery Freeman. Although the incinerator patent indicates a manufacturer's name and date, the patent only refers to the gas jets entering its fire box. Because of this, we know that this feature was gas operated.

**TABLE 5.3. ARTIFACTS ASSOCIATED WITH INCINERATOR FEATURE**

nails, nail fragments, spikes	486
glass bottle and/or fragments	281
metal fragments	182
ceramic/earthenware fragments	12
brick fragments	174
mortar/concrete fragments	30
tile fragments	10
slate	8
clinkers	200+ +
coal	3
glass tubing	50
cartridges	20
horseshoe	1
golfballs	2
suspender clips	1
bottle opener	1
keys	2
wire fragments	21
nuts and bolts	28

Several indirect lines of evidence, however, offer conflicting functions for this feature. As described in a military dictionary, an incinerator is "a furnace designed to burn camp refuse" (Garber, 1936:163). If the feature was indeed an incinerator, it could possibly explain the "refuse" types of artifacts that were found in association with it (melted glass, metal miscellany etc., Table 5.3).

A bi-monthly maintenance report from Nelson B. Kieler to Major McIndoe dated May 27, 1911, mentions that "[he] was unable to locate the trouble at Battery Freeman as covers are already provided over the chimneys for the fireplaces..." (National Archives, Box 470; p. 128). It is not clear what fireplaces the report is referring to; fireplaces do not appear in the blue print of Battery Freeman nor in the literature other than this report. The report also mentions a chimney, but it is unclear whether the chimney was a brick structure similar to the incinerator or a vent pipe with a lid (as observed on the second floor of Battery Pratt). The latter

function is unlikely because the incinerator was located outside of the battery toward the southwest corner. But the question remains whether this feature is the fireplace that is mentioned in the report or an incinerator that was not discussed.

One additional explanation for the function of this feature may rest in the number of clinkers that were associated with this unit. The presence of clinkers is a good indicator that this feature was associated with blacksmithing activities. It was not uncommon to have blacksmith shops within military compounds for on-site construction, maintenance, and other miscellaneous uses. Thus, considering the location of the incinerator and its resemblance to a forge, it is more than likely that this feature was associated with blacksmithing activities during the construction of Battery Freeman (i.e., to construct metal components such as window bars and shutters from iron railroad rails).

Other artifacts in this assemblage include over 400 nails and nail fragments, various metal objects, cartridges, glass fragments, two golf balls and a horseshoe. Two bases of glass bottles were recovered from within the firebox. These bottles had "WF & S 5 MIL" embossed on them, identifying an age for the bottles from 1900-1929 (Toulouse, 1971:536). We were able to partially reconstruct one of these bottles from twenty-three fragments associated with one of the bases. One purple glass fragment recovered in this assemblage may be the "solarized" glass described by Jones and Sullivan (1989) that was originally colorless but turned slightly purplish after prolonged exposure to sunlight. Jones and Sullivan (1989:13) suggest that "this type of glass was most common from the last quarter of the 19th century until World War I."

The presence of golf balls adds to the complexity of the site, but because the adjacent grounds of Old Fort Stevens also served as a golf course during the mid-1930s (Figure 3.6), the golf balls are most likely derived from this source. The

horseshoe may reflect a transitional time in history when horses were still in use for labor practices (pre-motorized equipment). Alternately, if the incinerator feature was a forge, the presence of the horseshoe (and/or other metal items) would be expected since metal scraps are often associated with blacksmithing activities.

It is interesting to note that all of the steel-jacketed .45 caliber slugs (N=8) were found within this assemblage at depths ranging from 80 cm to 100 cm. There were also four .22 caliber bullets; two .30-06; one fired bullet; and a flattened slug. The presence of the cartridges, especially the .45 caliber slugs, and the copious amount of bottle glass fragments may suggest the use of the feature as a backdrop for target practice.

#### *Assemblage 3: Battery Freeman Floor*

The Battery Freeman floor was located at a depth of 70 cm and the total Battery Freeman occupation layer above the concrete floor was 20 to 30 cm thick. Artifacts within the fill component above the floor consisted mostly of (in order of decreasing number) concrete chunks, tile fragments, nails, a few glass shards, and a cartridge headstamped "H" (Table 5.4). River pebbles were also recovered at this level. Several photographs were taken of the concrete battery surface and excavation ceased within this unit.

Although it was located elsewhere, one other feature associated with the Battery Freeman surface was vehicular tire tracks. The imprinted tire tracks were located at a depth of 80 cm to 90 cm (level 8) in Unit 3 and aligned in a east/west direction. A plaster cast mold of the these tracks was made. Also observed in this level was a lense of red soil which may be characteristic of a mixture of oil, ferrous metal fragments, and organic debris.

**TABLE 5.4. ARTIFACTS ASSOCIATED WITH  
BATTERY FREEMAN FLOOR**

concrete chunks	40
tile fragments	54
nails	53
glass container fragments	53
cartridges	2

*Assemblage 4: Bulkhead Wall - pre-1900*

The artifacts associated with the bulkhead wall feature (Figures 5.11, 5.12) were primarily wood fragments, nails and spikes, with fewer numbers of glass and tile fragments than found in the other test units (Table 5.5).

Of all the friction primer pins that were recovered during this excavation, 64 percent came from these test units. Friction primer pins were used in association

**TABLE 5.5. ARTIFACTS ASSOCIATED WITH THE BULKHEAD WALL**

metal fragments	35
wood fragments	20
nails, nail fragments, spikes	225
glass container fragments	81
glass tubing	5
tile fragments	105
friction primer pins	14
buckle	1
.22 bullets/or cap	2
.30 bullet casing	1

with the Rodman guns that were replaced when Battery Freeman was constructed. Their concentration in this area thus indicates preservation of pre-1900 artifacts. Because of their concentration and association with the bulkhead wall, the friction primers may be *in situ*. Their preservation may be related to modification of the

sallyport. Following the initial construction of the earthwork, the sallyport required several alterations and/or repairs because of poor drainage that contributed to wood deterioration (Sekora, 1989). During the last modification of the sallyport, it was moved slightly west of its former location. Hence, cultural materials that may have been within the former position of the sallyport would have been preserved.

### *Life at Battery Freeman*

Without the full history of Battery Freeman, very little is known about what some of the daily activities may have entailed. For example, what was a daily routine? Were there drills? If so, were they daily, weekly or bi-monthly? The artifacts do not provide direct information about these daily activities. Knowing that the fort was a coastal artillery unit, however, we can conclude that a typical routine may have entailed infantry formations, close order drills, ceremonies and inspection (Coast Artillery Field Manual, 1933). Normally the batteries were inspected weekly:

Artillery inspections are made with all individuals at their battle stations to ascertain the condition and mechanical function of all mechanism, instruments and devices, their state of preservation and appearance, the efficiency of the personnel in the performance of their duties individually and as a team, and to detect faults and deficiencies for the purpose of correcting them... (Coastal Artillery Field Manual, 1933:158).

It appears that during summer maneuvers, Forts Stevens and Columbia held target practices. An article entitled "Oregon Shore Guns Once Fired At Each Other-But Not In Anger" from The Oregon Journal (1968) (on file at the Oregon Historical Society), reported one particular incident in 1915-1916 in which:

...gun firing was about to commence... the guns, fired close...: With cast iron projectile fire one ranging salvo...! There was a deadly "boom" and smoke moved across the hillside... one shell missed the target-raft area and headed for Fort Stevens...the shell just missed the house tops of the NCO quarters and landed harmlessly "plop" in a grassy spot near Battery Freeman [no one was hurt and there were no damages to the property]...it was just a plain cast iron shell with no

explosive charge. It just buried itself in the soil... (OHS, Vertical File).

A coastal artillery unit was commanded by an artillery district commander. He was responsible for artillery instruction, drill and practice, and the purchase of supplies and accessories (Hines and Ward, 1910). A battery commander was the senior artillery officer at a battery, and was in charge of both administrative and tactical command (Hines and Ward, 1910). The battery commander oversaw daily attendance at drill and instruction, and was responsible "that the personnel of his battery is efficient in drill, in practice and in action" (Hines and Ward, 1910:6). Other members of the Coast Artillery Corps assigned to a battery included: range officer, emplacement officer, communication officer, searchlight officer, property officer, and minefield officer (Hines and Ward, 1910:77). In addition to the officers, a number of personnel were non-commissioned officers and graded men, including: master electrician, engineer, master gunner, chief loader, range-setter, and wireless operator, among others (e.g., Hines and Ward, 1910:78).



## CHAPTER 6

### DISCUSSION AND CONCLUSIONS

The 1865 Old Fort Stevens earthworks was the only one of this architectural design in the Pacific Northwest. The earthwork existed for 35 years before being impacted during the construction of Battery Freeman at the turn of the century. In 1939, the only remaining pre-1900 feature (parapet walls) along with Battery Freeman were destroyed in order to level the ground for a temporary tent campground for World War II enlistees.

The primary purpose of the 1989 Oregon State University archaeological excavation was to assess the integrity of the pre-1900 occupation of Old Fort Stevens to assist in the partial or whole reconstruction of the fort. As a result, we located the pre-1900 ditch and the intact Freeman occupation surface. Although some information on this period was recovered, the majority of the archaeological material was associated with the Battery Freeman occupation *ca.* 1900-1940. Of the 4,854 artifacts recovered, most can be confidently associated with the Battery Freeman phase and not to an earlier occupation. Of these artifacts, approximately 94 percent were from within the former earthworks. The remaining 6 percent of the materials were recovered from the ditch and thus cannot be tied directly to activities within the earthworks, particularly in view of the use of the ditch in later years as a dumping ground (Sekora, 1989).

Efforts currently underway to reconstruct the original earthworks of the Civil War era Old Fort Stevens mean that much of the remaining *in situ* archaeological record of Battery Freeman will be preserved but difficult to recover. Thus, in addition to its intrinsic value, the archaeological data that were recovered during

the 1989 excavation represent the primary source of this type of information that are likely to be available for documenting post-earthworks activities.

Archaeological data associated with Battery Freeman, combined with archival records, provide new information on this poorly known phase in the history of Fort Stevens. In particular, artifacts and archival information relate primarily to architectural features of the battery and indicate activities directly associated with its construction and military use.

Excavations also revealed several architectural features associated with the pre-existing earthworks, and a small but important component of the archaeological material relates to this phase as well.

The principal results from this study can be evaluated according to four criteria: (1) discussion of the history of the fort from its construction (1865) to its demolition (1940); (2) results from archival information; (3) discussion of the main stratigraphic components encountered during the 1989 excavation; and (4) results from artifactual analyses, including comparative methods.

### *History of the Fort*

Although Fort Stevens was built in 1865, interest in establishing a military presence in the Oregon Territory, and particularly the entrance to the Columbia River, long preceded its construction. This interest was fueled by boundary disputes, increasing numbers of settlers into the region, and resulting economic development (Johansen and Gates, 1957; Schwantes, 1989). Events in the early 1860s (potential conflict with Great Britain, Civil War) finally led Congress to provide funding for the construction of the nine-sided earthworks on the south side of the mouth of the Columbia River.

Construction of the original Fort Stevens on Point Adams was completed in 1865 under the supervision of Captain George Elliot. The fort was a nine-sided earthwork surrounded by a ditch, a typical design for forts constructed during that time period (e.g., Hines and Ward, 1910). The fort, however, was soon beset with problems of poor drainage due to a shallow water table: the ditch was often filled with water, although it was intended to be dry, and the wooden framework began to deteriorate because of water damage (Sekora, 1989). Congress was unwilling to provide additional funding for repairs, however, as they continued to struggle financially from the Civil War (Sarty, 1988). The lack of congressional interest in maintaining coastal defenses led to closing of Fort Stevens in 1884 (Hanft, 1980).

Almost at the same time as the fort's closing, however, there was increasing concern that the growing strength of foreign fleets might pose a threat to the coastal security of the United States. In 1885, therefore, the Board on the Fortifications or Other Defenses of the United States was formed, commonly referred to as the "Endicott Board" after its chairman William C. Endicott (Sarty, 1988). In 1886, the Endicott Board recommended expansion of coastal defense facilities, and in 1888, renewed fortification of coastal defense facilities was initiated (Floyd, 1985; Sarty, 1988). The Spanish-American War of 1898 precipitated specific interest in Fort Stevens as a defensive fortification, and the fort was subsequently reoccupied by the 3rd Artillery in 1898.

The modernization of Fort Stevens involved significant expansion, with the construction of several new concrete batteries outside the walls of the old earthworks, as well as construction of a battery (Battery Freeman) directly within the earthwork. Building new fortifications directly within existing earthworks or other forms of forts was a relatively common practice at the turn of the century (Robinson, 1977; Floyd, 1985). The implications of this practice to this study are

that there were only slight modifications to the earthworks when Battery Freeman was constructed, but both structures otherwise coexisted until they were demolished in 1940. There would thus be a close stratigraphic association between the two structures, with no intervening period of disturbance.

### *Archival Information*

Archival information has provided a detailed representation of the spatial setting of Battery Freeman with respect to the original position of the earthworks (e.g., Figure 5.2). The dimensions and many of the architectural elements can be deciphered directly from architectural plans of the battery (Figure 5.3) as well as from other contemporary coastal batteries (Figure 5.1). This information should be of value to the earthworks reconstruction project for its interpretative information, because the project documents the subsequent history and use of the earthworks following the Civil War.

In addition, this information affords an excellent example of how former earthworks were reoccupied by batteries during refortification of coastal batteries near the end of the nineteenth century (the "Endicott period") (e.g., Floyd, 1985).

Archival information also details the timing and progress of construction of Battery Freeman through early 1902. Specifically, archival records show that by October, 1901, most concrete had been laid. In November, 1901, most exterior work was completed and interior finish work was underway, such as painting and hanging of doors and windows. In December, 1901, electricity was installed and electrical instruments were tested. Interior work was completed in January, 1902, and the six-inch guns were turned over to the Artillery on January 17th.

Finally, archival information provides specific inventories of certain materials used in the construction of the battery, many of which have the potential to appear

as artifacts. In particular, the archival data identify electrical materials such as ammeters, dimmers and lamps, although none of these appear among the recovered artifacts.

### *Stratigraphic Information*

The stratigraphy exposed in test excavations in the old parade ground area and in the vicinity of the powder magazine indicates that, at the turn of the century, approximately one meter of the interior earthwork surface was removed to construct Battery Freeman, thereby eliminating any evidence of the earlier pre-1900 occupation. When Battery Freeman was dynamited in 1940, the remains of the structure, other materials, and the old earthwork parapet walls were bulldozed into the ditch and the entire surface was raised about one meter to the original level of the interior of Old Fort Stevens to accommodate a temporary tent camp built in preparation for World War II.

We discovered, however, that the 1900 to 1940 occupation surface behind (south) Battery Freeman was intact at a depth of 1 to 1.3 meters and that the concrete floor of a part of Battery Freeman also remained in place. Based on the location of the test pit in which the floor was found with respect to the former location of the battery, the floor was likely part of a concrete walkway that ran parallel to (east-west) the south side of the actual battery's superstructure.

We encountered little evidence of the pre-1900 occupation phase of Old Fort Stevens in the excavations. An important find was the remnant of the east bulkhead wall of the pre-1900 sallyport entrance at a depth of 1.2 meters. In addition, excavations located the north scarp of the moat and found it to be perfectly intact below the water table (Brauner, n.d.).

Although the 1864 to 1900 component in the Old Fort Stevens earthwork was destroyed by the construction of Battery Freeman, the stratigraphic information that we recovered indicates that a significant archaeological resource still remains in and around the old fortification. Specifically, the significant resource is the occupation surface behind (south) Battery Freeman within the walls of the earthwork and the contents of the surrounding moat below the water table.

The ground surface behind other turn-of-the-century batteries at Fort Stevens have been continually used since 1940, and cleaned up as the site function shifted from military usage to State Park. The 1900 to 1940 surface that we identified behind Battery Freeman, however, was buried instead. The occupation surface with all of its associated debris and features (including vehicle tracks) was effectively frozen in time in 1940. This information thus indicates that cultural remains relating to activities that commonly occurred behind an early 20th century gun emplacement can no longer be found behind extant batteries at Fort Stevens, but can be archaeologically recovered behind Battery Freeman (Brauner, n.d.).

### *Archaeological Analyses*

Archaeological analyses of the artifacts from the 1989 excavation entailed: (1) identification of several components based on their association with stratigraphic features; (2) further dating of materials (temporal characteristics); (3) typological identification of various material (glass, nails, tile, ceramics); (4) evaluation of the functions of various materials; and (5) interpretation of social and military aspects of human activity in the earthworks (see Appendix A for further description).

Unfortunately, because the site was bulldozed and many artifacts were mixed in with others only in the fill strata, it was not possible to identify any detailed

spatial distribution patterning of most of the artifacts, particularly those found in large numbers such as glass, ceramics, nails, tile, bricks, clinkers, and ammunition.

Nevertheless, preservation of some original features allowed identification of four assemblages of artifacts. Assemblage 1 represents the fill component that includes the materials that were bulldozed. Assemblages 2, 3, and 4, however, are associated with preserved features: the incinerator feature, the floor from Battery Freeman, and the bulkhead wall feature from the earthworks. Within the context of these features, some spatial patterning of artifacts was identified. For example, the incinerator feature had many cartridges, bottle glass fragments, brick fragments, nail and metal fragments. Friction primer pins and wood chips were mainly preserved in the bulkhead wall.

Most of the artifacts can be directly associated with the Battery Freeman occupation by their composition (for example, architectural materials associated with the concrete superstructure), by their association with the preserved incinerator feature, or where the artifacts can be directly dated, such as cartridges. Several artifacts could be confidently dated by style form and/or function to the pre-Battery Freeman phase. Some of these items include: a crossed cannon hat insignia, friction primers, and bottle glass fragments.

The comparative method permitted identification of the function of an artifact based on recognition of its use in an existing structure. This method was successful at Fort Stevens where several batteries that were built during the same period as Battery Freeman but are still standing (e.g., Smur, Clark, Pratt) contain architectural materials that were the same as those found included among the Battery Freeman materials. These batteries thus provide a critical resource for evaluating the function of a number of artifacts recovered from Battery Freeman. In particular, the specific function of many artifacts classified as "architectural", such

as clay tile fragments and metal wire and beams, was identified by observing their use in existing batteries.

The majority of the artifacts recovered (40 percent) are associated with the Battery Freeman superstructure (Architecture). Many of the architectural aspects of Battery Freeman such as location, design, and materials can be reconstructed in some detail from the archival information and by comparative studies. Because of this, many of the artifacts from Battery Freeman classified under "Architecture" can be evaluated and interpreted under relatively well-constrained conditions. Thus, a large number of artifacts found in the excavations, such as tile fragments and wire, were observed in existing batteries, and their specific functions identified. Most of the bricks and clinkers were associated with the incinerator feature, thus clearly establishing their function.

Of those artifacts classified under Architecture, the majority were nails (46 percent). Machine-made or "cut" nails were recovered throughout the site area. These type of nails are commonly used for both interior and exterior construction. There were a number of wire drawn nails or finishing nails, typically with slender shanks and almost globular heads. These nails were used primarily in the battery interior. Perhaps a remnant of the pre-1900 period, only one hand wrought square nail was recovered.

The remaining artifacts provide some information on activities associated with the battery that cannot be inferred from archival or comparative methods. A number of artifacts may be related to various aspects of life in the structure, although they may relate to activities following demolition of the battery. Some of the categories included personal items (i.e., clothing parts, buttons, indulgences), domestic items (ie., glass bottles, jars, ceramics), ammunition, and toys (i.e., golf balls, a marble) (Table 5.1).



Although a large number of the artifacts (32 percent) are classified under "Domestic Items", the majority of these (97 percent) are glass fragments. Because a single bottle may produce at least tens of glass fragments, the actual sample may represent only a few bottles. Furthermore, of the glass fragments recovered, a significant fraction were recovered from the ditch. The large number of glass fragments, therefore, does not necessarily indicate a strong "domestic" element to activities at the fort.

Glass bottles are generally good time markers. The manufacturer's name and date of manufacture of a glass container can often be obtained through bottle identification, especially if the vessel is unbroken. In many cases, however, all that remain of glass containers are glass fragments, such as from a disturbed site like Battery Freeman. Unless the fragments have diagnostic features, such as the lip, neck, and base portions, embossed or with other trademarks, it is difficult to identify the container, let alone be able to determine its function (i.e., container for beverages; soda bottle or beer bottle).

Because the archaeological evidence from glass fragments is equivocal, one can either assume that the men of Battery Freeman consumed many non-alcoholic and/or alcoholic beverages, or that the materials recovered are not at all tied to activities of the battery. For instance, during the years of abandonment in the 1920s, anyone had access into the earthwork interior and may have used it as a dumping ground or a shooting range. In addition, many of the fragments are from the ditch, which is known to have been used as a dumping ground. Perhaps many of these items, as well as many of the architectural materials relating to Battery Freeman that were recovered, were placed in piles, some of which may have been burned, just prior to destruction of the structure.

Since the site of Battery Freeman was not one of domesticity (i.e., living quarters), the rather insignificant number of ceramic and other utilitarian vessel fragments is to be expected. The presence of even a few fragments suggests that either the enlistees or officers occasionally brought a cup of coffee or a plate of snacks from their living quarters, or that the ceramic fragments are remnants of household items that were disposed of during the years of abandonment.

Several of the artifacts, such as buttons and buckles, appear to be related to the military lifestyle expected for Battery Freeman. The button marked "CARTER'S DIAMOND BRAND" has a diamond logo impressed in the center. Judging by the trademark, this button was probably manufactured by the William Carter Company of Needham Heights, Massachusetts as early as 1865 (BNFI, 1947:13) or Carter and Yost of Philadelphia established in the 1850s. In his 1979-1980 excavation of the officers' quarters, Harrison (Harrison and Ross, 1989; Harrison, 1990) also recovered a button of this type.

The stem portion of a clay pipe may be similar to those found during Harrison's 1979-1980 excavation of the officers' quarters. Several of the stem fragments that Harrison recovered had the manufacturer's name of "MCDOUGALL" on one side and "GLASGOW" on the opposite side. These pipes were first manufactured in 1847 by the firm Duncan McDougall and Company in Glasgow, Scotland (Oswald, 1975:205).

### *Conclusions*

The 1989 excavations revealed that features from Battery Freeman and the pre-1900 earthworks are preserved beneath the fill unit behind (south) Battery Freeman. Further cultural remains associated with an early 20th century gun emplacement could be systematically recovered behind Battery Freeman at a

reasonable cost. In the interim, the >1 meters of sand capping the significant cultural deposits will protect them from any activity which does not involve subsurface disturbance.

Significant cultural materials situated at depths >3 meters below the contemporary ground surface in the ditch include organic and inorganic remains which span the entire history of Old Fort Stevens. The eventual interpretative potential of these remains cannot be overstated. The only remaining evidence of the pre-1900 occupation of the fortification will be found in the lower portions of the moat. Because of the unstable environment in which these materials are now found, the technology required to safely excavate a site in a sandy matrix below the water table and ensure state-of-the-art control would drive recovery costs at least into the six figures. Until a suitable recovery technology is developed at a reasonable cost, this resource is protected in its water-logged state at depth below the surface (Brauner, n.d.).

The features that were excavated were significant in that they provided the best evidence for establishing the spatial context of the artifacts associated with them. The remaining artifacts were recovered from either the fill unit or the ditch, and their spatial relationships were consequently lost.

The great majority of artifacts recovered from the 1989 excavation are associated with Battery Freeman architecture. These include: concrete, nails, tile, wire, metal fragments, the incinerator feature (clinkers, bricks), and glass fragments. Of the remaining artifacts, very few are related to military or social activities, and their low numbers and lack of original spatial context prevented any interpretations of their significance to such activities.

Some information relating to the pre-1900 architecture of the earthworks was recovered. The bulkhead wall, the scarp of the moat, and one hand-wrought nail

were the primary remnants of the pre-1900 structure. Other archaeological artifacts that date from the pre-1900 phase, including minie balls and primers, indicate use of small guns in the earthworks. Overall, however, the poor archaeological recovery of pre-1900 materials and features is a result of the lowering of the original earthworks' structure by 1 meter when constructing Battery Freeman.

Archival information provides a detailed understanding of Battery Freeman architecture and its spatial relationship to the earthworks. The archival record is almost mute, however, on various social or military activities during both pre- and post-1900 phases of the earthworks. No living quarters were placed within the interior of the structure at any time. The activities within the structure were probably restricted specifically to military work, and artifacts associated with domestic activities are thus not expected. The archival record provides no information on what routines or drills occurred, but comparison to such activities outlined in a Coast Artillery Field Manual (1933) indicates what the nature of daily military activities may have been.

The archival and archaeological records of Old Fort Stevens have thus provided important architectural information on Battery Freeman, a previously poorly known phase in the history of the earthworks. A limited amount of information relates to the pre-1900 history of the fortification, but there is a significant potential for recovering additional materials both from this phase as well as from Battery Freeman. Neither the archaeological nor archival records were useful in identifying social or military activities related to the earthworks.

## REFERENCES CITED

- Adams, W.H., Gaw, L.P., and Leonhardy, F.C.  
1975 *Archaeological excavations at Silcott, Washington: The Data Inventory.* Laboratory of Anthropology, Washington State University, Reports of Investigations 53, Pullman.
- Babits, L.E.  
1988 *Military Records and Historical Archaeology.* In *Documentary Archaeology in the New World:* edited by Mary C. Beaudry. Cambridge, Cambridge University Press, p. 119-125.
- Baker, V.W.  
1940 *An Area Plan for Land Use, Clatsop County, Oregon.* United States Department of Agriculture, Bureau of Agricultural Economics, 58 pp.
- Barnes, F.C.  
1969 *Cartridges of the World.* Chicago: Follett Publishing Company.
- Baumann, P.  
1991 *Collecting Antique Marbles.* Wallace-Homestead Book Co., Radnor Pennsylvania.
- Bealer, A.W.  
1976 *The Art of Blacksmithing.* Funk and Wagnalls, New York, 438 p.
- Beaudry, M.C.  
1988 *Documentary Archaeology in the New World.* Cambridge University Press, Cambridge, U.K., 218 p.
- Bell, J.  
1989 *Report of Remote Sensing Survey of Old Fort Stevens.* Unpublished Final Report for Friends of Old Fort Stevens.
- Brauner, D.R.  
n/d *Archaeological Assessment of the Old Fort Stevens Site (ORCLT1), 2Clatsop County, Oregon.* Report prepared for the Friends of Old Fort Stevens, Fort Stevens State Park, Hammond, Oregon.
- 1992-  
1993 Personal Communication, Department of Anthropology, OSU, Corvallis.

- Butler, K.D. Jr.  
1977 *The Principles of Horseshoeing II. An Illustrated Textbook of Ferrier Science and Craftmanship.* Douglas Butler Publishers, Maryville, MO.
- Coast Artillery Field Manual  
1933 *Seacoast Artillery Part One, Tactics.* United States Government Printing Office, Washington, D.C.
- Dixie Gunworks  
1990 *Dixie Gunworks, Inc.: Black Powder Shooting Supplies and Antique Gunparts.* Catalogue #139, Union City, TN.
- Edwards, W.B.  
1962 *Civil War Guns. The Complete Story of Federal and Confederate Small Arms: Design, Manufacture, Identification, Procurement, Issue, Employment, Effectiveness, and Postwar Disposal: The Stackpole Company, Harrisburg, PA, 444 p.*
- Ferguson, L.G.  
1977 *An Archaeological-Historical Analysis of Fort Watson: December 1780-April 1781.* In *Research Strategies in Historical Archaeology:* edited by Stanley South. Academic Press, Inc., New York p. 41-72.
- Floyd, D.E.  
1985 *United States Coast Defense, 1775-1950: A Bibliography.* Historical Division Office of Administrative Services, Office of the Chief of Engineering, Washington, D.C.
- Gurcke, K.  
1987 *Bricks and Brickmaking: A Handbook for Historical Archaeology.* University of Idaho Press, Moscow.
- Hackley, F.W., Woodin, W.H., and Scranton, E.L.  
1969 *History of Modern U.S. Military Small Arms Ammunition, Vol. I. 1880-1939.* The MacMillan Company, New York, 315 pp.  
1978 *History of Modern U.S. Military Small Arms Ammunition, Vol. II 1940-1945.* The Gun Room Press, Manufactured in the U.S.A., 297 pp.
- Hanft, M.  
1973 *The Cape Forts: Guardians of the Columbia.* Oregon Historical Society, Portland, OR, 63 pp.

- 1980        *Fort Stevens: Oregon's Defender at the River of the West.* Oregon State Parks and Recreation Branch, 360 pp.
- Harrington, J.C.  
1978        *New Light on Washington's Fort Necessity.* In *Historical Archaeology: A Guide to Substantive and Theoretical Contributions*, edited by Robert Schuyler. Farmingdale, New York, Baywood Publishing Company, Inc., p. 91-138.
- Harrison, B.F.  
1989        *Archaeology at Old Fort Stevens: Review of Previous Research:* Unpublished manuscript, 25 pp.  
  
1990        *Old Post Archaeology: Excavations at Fort Stevens 1979-1980.* Clatsop Community College, Astoria, OR, 169 pp.
- Hines, F.T., and Ward, F.W.  
1910        *The Service of Coast Artillery.* New York, 563 pp.
- Irving, W.  
1987        *Astoria: Adventure in the Pacific Northwest.* KPI Limited, London, 440 pp.
- Jones, O., and Sullivan, C.S.  
1985        *Glass Glossary: The Parks Canada Glass Glossary for the Description of Containers, Closures and Flat Glass.* Research Publications, Parls Canada, Ottawa, Canada.
- Kerrigan, E.E.  
1967        *American Badges and Insignia.* Viking Press, New York, 286 pp.
- Komar, P.D., and Li, M.Z.  
1991        *Beach Placers at the mouth of the Columbia River, Oregon and Washington:* *Marine Mining*, v. 10, p. 171-187.
- Lindstom, D.  
1993        *The Last Years of Service for the 15 inch Rodman.* In *Battery. Fort Stevens Guardian of the Mighty River of the West.* Friends of Old Fort Stevens, Inc., Spring, 1993.
- Logan, H.C.  
1948        *Cartridges - A Pictorial Digest of Small Arms Ammunition.* Standard Publications, Incorporated, Huntington, West Virginia.

- Luscomb, S. C.  
1967 *The Collector's Encyclopedia of Buttons.* Crown Publishers, Incorporated, New York.
- Miller, E.G.  
1958 *Clatsop County, Oregon: Its History, Legends and Industries.* Portland, Oregon: Binford and Mort, 291 p.
- Mercer, H.C.  
1925 *The Dating of Old Houses.* Old time New England, vol. 14, no.4.
- National Archives (N/A)  
Bi-weekly reports to Captain Langfitt, Corps of Engineers, National Archives (NA), Seattle, Washington, Box 467: Books 3:335, 343, 357, 365, 366, 371, 391, 398, 405, 407, 416, 431; Box 470:128.
- Niem, A.R., and Niem, W.A.  
1985 *Oil and Gas Investigation of the Astoria Basin, Clatsop and Northernmost Tillamook Counties, Northwest Oregon:* Department of Geology and Mineral Industries, State of Oregon, OGI-14, scale = 1:100,000.
- Oregon Historical Society Microfilm Guide  
Vertical file #8 (F) Forts.
- Oregon Journal  
1968 "*Oregon Shore Guns Once Fired At Each Other But Not In Anger*".
- Oswald, A.  
1975 *Clay Pipes for the Archaeologist.* British Archaeological Reports 14.
- Pague, B.S.  
1897 *Fourth Biennial Report of the Oregon Weather Bureau.* W.H. Leeds, Salem, OR.
- Priess, P.J.  
1974 *Wire Nails in North America.* Newsletter of the Society for Historical Archaeology, vol.7, no. 1, pp. 22-28.



- Reese Padlock Co.  
1926 *Illustrated Catalog Number 4: Padlocks.* Reese Padlock Co., Lancaster, PA, 50 p.
- Robinson, W.B.  
1977 *American Forts: Architectural Form and Function.* University of Illinois Press, 229 p.
- Rosenfeld, C.  
1993 Personal Communication, Department of Geosciences, OSU, Covallis.
- Roenke, K.G.  
1978 *Flat Glass: Its Use as a Dating Tool for Nineteenth Century Archaeological Sites in the Pacific Northwest and Elsewhere.* Northwest Anthropological Research Notes, v. 12, No. 2, Part 2, Moscow, Idaho, 128 p.
- Sarty, R.F.  
1988 *Coast Artillery 1815-1914.* Museum Restoration Service, Historical Arms Series no. 21, 48 p.
- Schwantes, C.A.  
1989 *The Pacific Northwest.* Lincoln and London: University of Nebraska Press.
- Sekora, L.  
1989 *Architectural History of the Old Fort Stevens Earthwork.* Unpublished manuscript submitted to the Friends of Old Fort Stevens, 39 p.
- South, S.  
1977 *Method and Theory in Historical Archeology.* New York, New York, Academic Press, Inc., 345 p.
- Sprague, R.  
1980 *A Functional Classification for Nineteenth and Twentieth Century Sites in Historical Archaeology.* North American Archaeologist, 2:251-261.
- Toulouse, J.H.  
1971 *Bottle Makers and Their Marks.* Thomas Nelson, New York, New York.

Twenhofel, W.H.

1946 *Mineralogical and Physical Composition of the Sands of the Oregon Coast from Coos Bay to the Mouth of the Columbia River.* Oregon Department of Geology and Mineral Industries Bulletin 30, 46p.

U.S. Department of Commerce

1985 *Local Climatological Data, Astoria, Oregon.* U.S. Government Printing Office, Washington, D.C.

Victor, F.F.

1872 *All Over Oregon and Washington.* John H. Carmany & Co., San Francisco.

## **APPENDIX**

## APPENDIX A. DESCRIPTION OF ARTIFACTS

In historical archaeology, the period during which artifacts were manufactured can be arrived at through documents. The knowledge of manufacture dates for artifacts is an invaluable aid in the determination of occupation dates for historic sites. This is not to say that the manufacture date and the occupation date are the same, but that there is a connection between the two in that the manufacture date provides a date after which the object must have found its way to the ground (South, 1977).

The format for this appendix has been adapted from Adams et al (1975), *Archaeological Excavations at Silcott: Data Inventory*, in that the artifacts are described concisely and where possible accompanied with a visual representation. I first summarize the artifacts within a category and then provide a detailed description (i.e., measurements, color, type) of the artifacts particularly those that have diagnostic attributes, the manufacturer and function where known and the provenience of the artifacts. As mentioned in the text, the 1989 archaeological excavation yielded artifacts that were mostly associated with the Battery Freeman superstructure.

### *Personal Items*

From a total of 4,854 artifacts, a very small percentage (0.5%) falls within the personal items category. Artifacts listed in this category include items utilized by an individual. Most of the personal items (31%) are classified under the secondary level: clothing. Other personal items include a pocket watch, coins, clay pipe, footwear, grooming and recreation.

Clothing: There were eight unidentifiable cloth fragments, seven of which were recovered from Unit 9, level 10, and two from Unit 2, level 7; an oil cloth (Unit 6, level 9); a cloth rivet made of brass; two suspender buckles stamped "NEWPORT" from Unit 1, level 8; a belt or strap buckle and; the following metal buttons:

"CARTER'S DIAMOND BRAND", diameter 22 mm; Unit 1, level 8; N=1.

Decorative, Brass; diameter 16 mm; Unit 1, level 10; N=1.

Metal, 4 hole plain; corroded; diameter 15 mm; Unit 3, level 10; N=1.

Artifacts similar to those described above with the exception of the oil cloth fragment, were also recovered during Harrison's 1979-1980 excavation of the officers' quarters. Figure A-1 provides a photograph of the belt buckle and suspender clip.

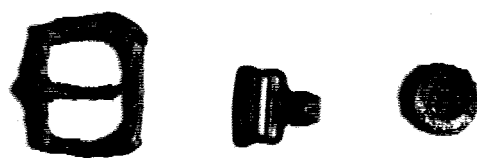


FIGURE A-1. Belt buckle and suspender clip.

Pocket tools and accessories: The make and manufacture of this pocket watch cannot be deciphered because it is heavily corroded. The watch is circular with a 47 mm diameter and is made of brass and was recovered from Unit 1, level 5 (Figure A-2).

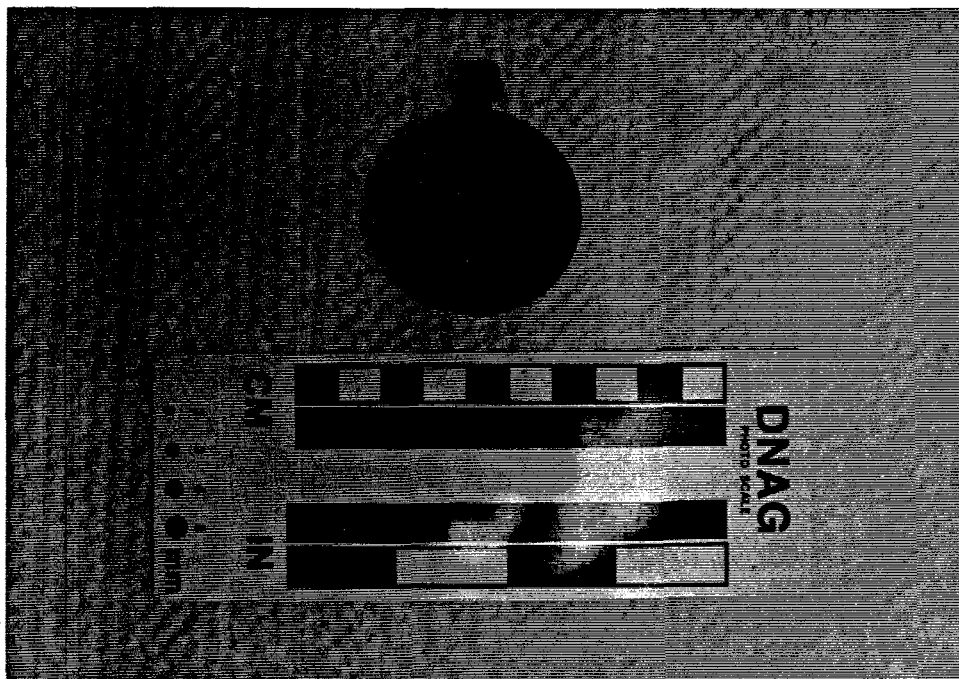


Figure A-2. Pocket Watch.

Coin: A U.S. copper Indian Head penny dated 1903 was located within the first level of the fill component in Unit 1.

Indulgences: One stem portion of a clay pipe made of white kaolin was unearthed in the fill component Unit. Harrison (1979, 1980) recovered a number of these clay pipes impressed with the manufacturer's mark "MCDUGALL" on one side and "GLASGOW" on the opposite. It is possible that these pipes were made by the firm of Duncan McDougall and Company in Glasgow, Scotland as early as 1847 (Oswald, 1975:205). Oswald (1975) states that white clay pipes have been quite common to historic sites.

Footwear: One deteriorated heel fragment of a shoe or boot and an eyelet was discovered in the fill component.

Grooming: A fragment of a comb was found in the fill component of Unit 4, level 8. The comb is black with the etching "COMB COS UNBREAK...", and is similar to a comb that was found during Harrison's 1979-1980 excavation ("I.R. COMB CO's UNBREAKABLE GOODYEAR 1851"). According to Luscomb (1967, p. 91), the "GOODYEAR 1851" refers to the patent received by Nelson Goodyear in 1851 for an improvement in the manufacture of India rubber.

Recreation: A total of three golf balls were collected from Unit 1, levels 6 and 7. The balls are white and pock-marked with a diameter of 40 mm. The trademark "AAISHNET" appears on one of the balls. Since there was a golf course adjacent to the earthwork as shown in a 1939 aerial photograph (Figure 3.6; Chapter 3), it is very likely that these balls came from there.

Another recreational item found was a marble in Unit 2, level 6. The marble is made of colorless glass with multi-color (yellow, brown, green, royal blue) interior swirls, and has a diameter of approximately 15 mm. There are no visible seams and the shape is nearly a perfect spheroid. These characteristics are good indicators that marbles of this type were mass produced in the United States by machine around the turn of the century (Baumann, 1991).

### *Domestic Items*

While it appears that 32% of the total artifacts recovered fall within the functional category associated with domesticity, it must be noted that a large number (94%) of these artifacts are glass bottle fragments. Artifacts classified under Domestic items include glass containers, container tops, bottle opener, brass box latch, ceramic flatware and hollow ware fragments, bed spring fragments, stove parts, light bulb fragments, d-cell battery fragment and keys.

Glass Containers: Shape, size, color and trademark of a bottle are good indicators of what the vessels may have contained. In general, trademarks and symbols are datum points in determining the history and ages of bottles. If the mark was used for many years, we may have to rely on other means to obtain a date (Toulouse, 1971).

Table A-1 summarizes the glass container fragments recovered from the interior. As shown in the table, the majority of the glass are body fragments of various colors (clear, amber, aqua, green, cobalt and pink) and range in thickness from .0625 -.165 inches. One purple glass fragment as discussed in Chapter 6, was recovered from Unit 1, level 7.

*Whole Bottles:*

1. soda bottle: light green, circular, crown top, body embossed "COCA COLA" "TRADEMARK REGISTERED MIN. CONTENTS 6-FL-OZS" on one side; the other side is embossed with "TRADEMARK REGISTERED BOTTLE PAT'D DEC. 25 1923"; base embossed "PORTLAND OREGON" with the Owens trademark (a diamond shape within a oval); 165 mm length; 60 mm diameter; bore diameter 15 mm; ditch (Figure A-3b).
2. whiskey bottle (reconstructed): amber glass, continuous thread top with cap, ovate, body embossed with leaves and "FEDERAL LAW FORBIDS SALE OR RE-USE OF THIS BOTTLE, D 11 56" on the other side "ONE PINT"; base embossed "TM REG US PATENT OFF"; seams on sides; length 172 mm, base diameter 91 mm x 46 mm; bore diameter 25 mm; cap length 38 mm; Unit 1, level 2; manufacturer Owens Illinois Pacific Coast Co dates 1932-1943, however, the Coast division used the trademark from 1943 to the present (Figure A-4a).
3. probably whiskey bottle: clear glass, cork top, seam on one side, length 238 mm, bore diameter 20 mm, base diameter 70 mm; N=2, ditch (Figure A-4b).
4. probably whiskey bottle: clear glass with light green tint, crown top finish, seam on two sides, length 248 mm, bore diameter 22 mm; ditch (Figure A-5a).
5. type unknown: light green glass, crown top finish, seam on two sides and across shoulder; base embossed "LOUIS BOENTCEN ASTO... ASTORIA ORE."; length 200 mm, bore diameter 20 mm; base diameter 61 mm; ditch (Figure A-5b).
6. beer bottle: amber glass, crown top finish, circular with seam on one side, length 241 mm, base embossed "18 S 37"; one interior; 2 ditch (Figure A-5c).
7. probably whiskey bottle: clear glass, circular, cork lip, seams on two sides from neck to base bottom, length 275 mm; bore diameter 20 mm; base embossed "1884"; ditch (Figure A-5d).
8. medicine bottle: clear glass, cork-stoppered, ovate, seam on two sides, length 97 mm, bore diameter 14 mm; ditch (Figure A-6).
9. medicine bottle: amber glass, screw top, circular with seam on both sides, length 101 mm; diameter 40 mm; bore diameter 15 mm; base embossed "7 [owens symbol] 2 4"; body heal embossed "DURAGLAS"; ditch (Figure A-3a).

**TABLE A-1: SUMMARY OF GLASS CONTAINERS  
WITHIN THE INTERIOR**

<b>Artifact Subtype</b>	<b>Number</b>	<b>Percentage</b>
clear vessel glass; bottles	1	.1%
clear vessel glass; body fragments	842	94.9%
clear vessel glass; base fragments	18	2.0%
clear vessel glass; neck fragments	27	3.0%
<b>TOTAL</b>	<b>888</b>	<b>100.0%</b>
clear glass; melted	<b>TOTAL</b>	<b>24</b>
		<b>100.0%</b>
amber vessel glass; bottles	2	1.6%
amber vessel glass; body fragments	113	93.4%
amber vessel glass; neck fragments	6	5.0%
<b>TOTAL</b>	<b>120</b>	<b>100.0%</b>
aqua vessel glass; body fragments	<b>TOTAL</b>	<b>128</b>
		<b>100.0%</b>
green vessel glass; bottles	1	1.5%
green vessel glass; body fragments	62	97.0%
green vessel glass; base fragments	1	1.5%
<b>TOTAL</b>	<b>64</b>	<b>100.0%</b>
dark green vessel glass; body fragments	6	100.0%
pink vessel glass; body fragments	13	100.0%
purple vessel glass; body fragment	1	100.0%
cobalt blue vessel glass; neck fragments	1	100.0%
milk glass vessel fragments; jar	2	100.0%



10. homeopathic bottle: clear glass, circular; length 57 mm, bore diameter 10 mm, 16 mm diameter; Unit 6, level 8 (Figure A-3c).

TABLE A-2: SUMMARY OF WHOLE BOTTLES

<u>Interior</u>	<u>Ditch</u>
clear, glass N=1	clear, glass N=5
amber, glass N=2	amber, glass N=3
light green, glass N=1	light green, glass N=1



FIGURE A-3. Whole bottles. (3a) medicine (3b) soda and (3c) homeopathic.



FIGURE A-4. Whole whiskey bottles (4a,4b).

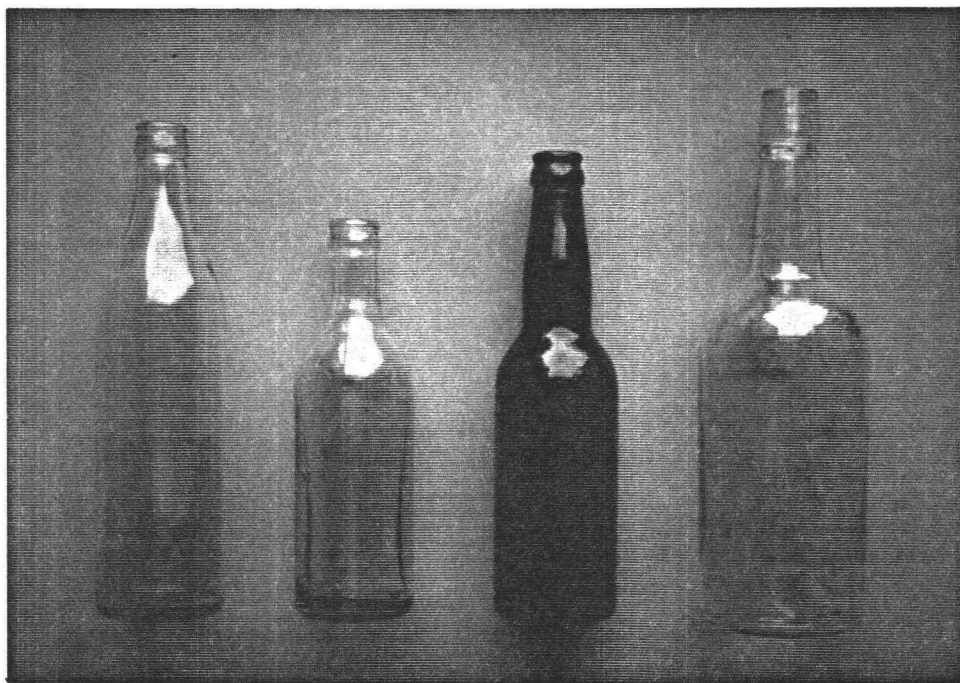


FIGURE A-5. Bottles: whiskey (5a, 5d), type unknown (5b), and beer (5c).

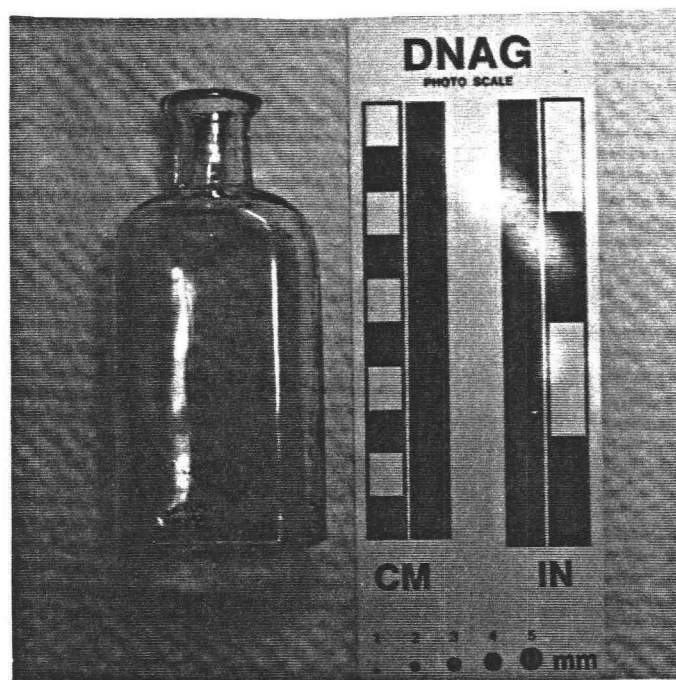


FIGURE A-6. Cork-stoppered medicine bottle.

*Base Fragments with Trademarks:*

type unknown: clear glass, circular, base embossed "1884"; diameter 84 mm; Unit 1, level 10; N=2.

whiskey bottle: clear glass, circular, base embossed "WF & S/MILW", Unit 1, level 7.

whiskey bottle: clear glass, circular, base embossed "WF & S/5 MIL", Unit 1, level 12. According to Toulouse (1971), these two bottles were manufactured by William Franzen and Son, from Milwaukee, Wisconsin, dates 1900-1929).

type unknown: clear glass, circular, base embossed with a double ring circle ~ 20 mm; Unit 6, level 8.

probably a whiskey bottle: clear glass, oblong, base embossed "2684"; ditch.

clear glass, rectangular, base embossed "I" inside a diamond; Unit 3, level 8.

probably a whiskey bottle: clear glass, square with beveled corners, base embossed with overlapping diamond symbols with the number "1330" below; 50 mm<sup>2</sup>.

beer bottle: amber glass, circular, base embossed "...BERPA...", Unit 1, level 12.

type unknown: light green, circular, base embossed "13 14"; Unit 1, level 7.

beer bottle: amber glass, circular, base embossed "40...13"; Unit 8' level 1.

beer bottle: amber glass, circular, base embossed "20 O"; diameter 60 mm.  
528-GB

(Owens-Illinois trademark).

Owens took over the Pacific Coast assets of the Illinois Glass Co., in 1929. The coast plants use the general Owens-Illinois trademark. The plant designation is the number on the left side of the diamond (in this sample, the number 20 designates the Oakland, California plant) and the year is shown on the right side. The bottom number refers to the mold cavity number (Toulouse, 1970).

whiskey bottle: amber glass, ovoid, base embossed "TM. REG. US PAT OFF...10"; Owens-Illinois trademark.

wine bottle: dark green, circular, pushup base; base diameter 75 mm; Unit 3, level 7.

type unknown: aqua glass, circular, base embossed "10" in a three ringed circle with the letter "A" to the right of the circle and; a seam below the number.

whiskey bottle: light green glass, rectangular, base embossed with "W".

#### *Base/Body Glass Fragments Recovered from the Ditch:*

type unknown: clear glass, circular, base embossed with "I" inside of a diamond; 80 mm diameter (trademark of Illinois Glass Co., Alton, IL, dates 1873-1929).

probably a whiskey bottle: clear glass, oblong, base embossed "2684".

type unknown: clear glass, circular, base embossed "10 OZ".

type unknown: clear glass, rectangular, base embossed "IK"; diameter 25 mm x 60 mm.

type unknown: clear glass, rectangular, base embossed "O-CEDAR"; diameter 75 mm x 45 mm; partial body portion with seam.

type unknown: clear glass, oblong, base embossed "DI" "56-43" with the owens symbol (a diamond overlain perpendicular to an oval).

beer bottle: amber glass, circular, base embossed "523 NW 48" with the number "4" below; (manufacturer is Northwestern Glass Co, South Seattle, Washington, dates 1931 to present); N=2.

beer bottle: amber glass, circular, base embossed "...43".

whiskey bottle: amber glass, circular, body side embossed "...UART 4/5 QUA...".

probably a beer bottle: aqua glass, circular with seam, body embossed "CONTEL..."; ditch.

probably a beer bottle: aqua glass, circular, body embossed "...NTS 12 1/..."; ditch.

probably a beer bottle: light green glass, circular, body embossed "3\1"; ditch.

jar: clear glass, circular, body embossed "S.F.& P"; dates 1876-1902, San Francisco and Pacific Glass Works "K..").

jar: clear glass, circular, body embossed "..OMI.." quite possibly the partial lettering of "ECONOMY" (Kerr Glass Manufacture, Co., Portland, OR, dates 1903-1909.

Container tops and bottle opener: Most of the container tops were found in Units 1 and 3, levels 5 and 6. There were two plastic bottle caps with male threads and a plastic textured cap with a screw thread. Other container tops include: one bottle crown cap, a large metal screw cap, a large brass container top and a bell shaped ceramic stopper (Figure A-7). One metal bottle opener with a overall length of 82 mm was located in Unit 12, level 6. Also, a glass bottle stopper was found in Unit 1, level 6.

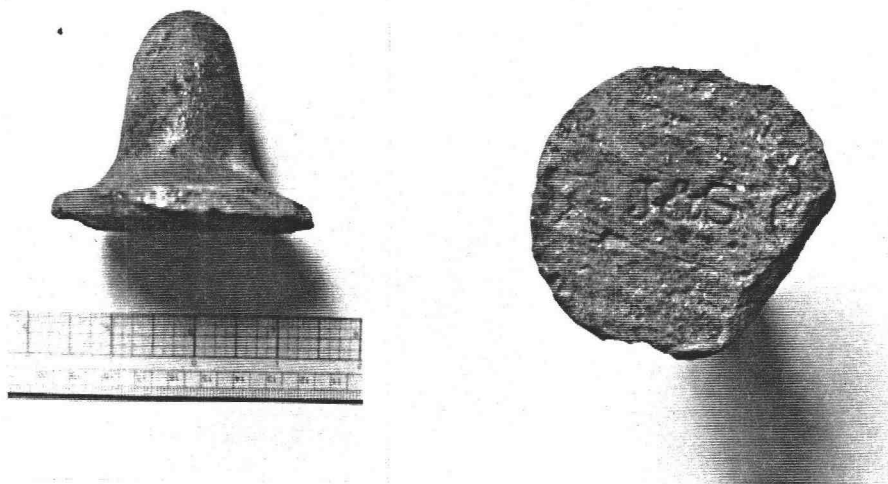


FIGURE A-7. Ceramic stopper.

**Brass Box Latch:** A brass box latch (35 mm x 21 mm) with four screw holes and an eye loop (for the lock) was found in Unit 1, level 3. The latch has a piece of wood attached (Figure A-8).

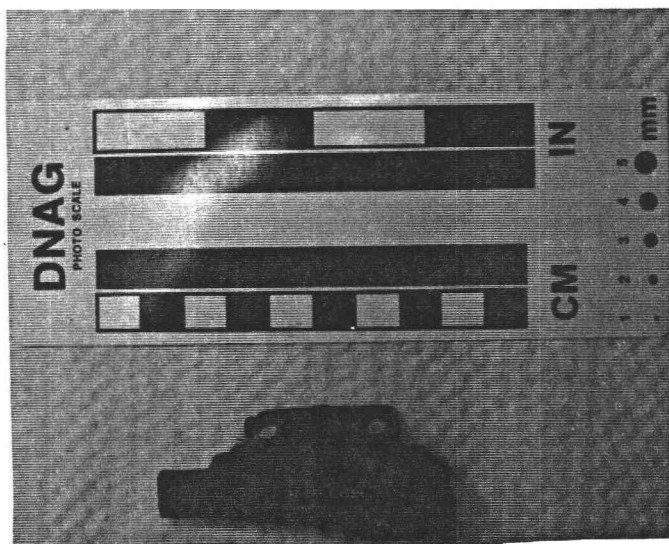


FIGURE A-8. Brass box latch.

**Ceramic flatware and hollow ware:** Of eleven white earthenware fragments, there was one base portion with a manufacturer's name. The base fragment has an alkaline glaze and a slightly raised edge. The basemark is in green lettering with the name "C.L....ALTWASSEY...SILESLE". The other white ceramic fragments range in size from 10 mm to 70 mm with thicknesses of 1mm to 5mm.

There were also two white ceramic fragments with blue transfer print of a vertical and horizontal line patterned design, 5 mm thick and; one slightly-coarse hollow ware vessel fragment, green/blue with dark specks (exterior) and white with black specks (interior), measuring ~50 mm; base-lip height 10 mm, approximately 3 mm thick.

**Stove Parts:** A circular stove top lid with a diameter of 8 inches, stamped "648, 348" was found in the ditch. A stove pipe fragment and mica sheet fragments were also found. These items may have been associated with the incinerator feature or perhaps were discarded in the ditch when the fort was used as a dumping ground.

**Light Bulb:** Several light bulb fragments which were probably used to light up the interior of the battery were recovered. A total of five interior portions and two thin pieces of glass bulb fragments were found in Unit 1, level 8; and a brass bulb base found in Unit 12, level 1.



**Keys:** Three skeleton keys ranging in length from 75 mm to 82 mm with slender shanks (width = 4 mm) were found in Unit 1. These keys are similar to types that are designed for interior doors. The smaller key, found in the ditch, is made of brass and has a hollow key shaft, typical of keys for padlocks (Reese Padlock Co., 1926) (Figure A-9a,b,c).

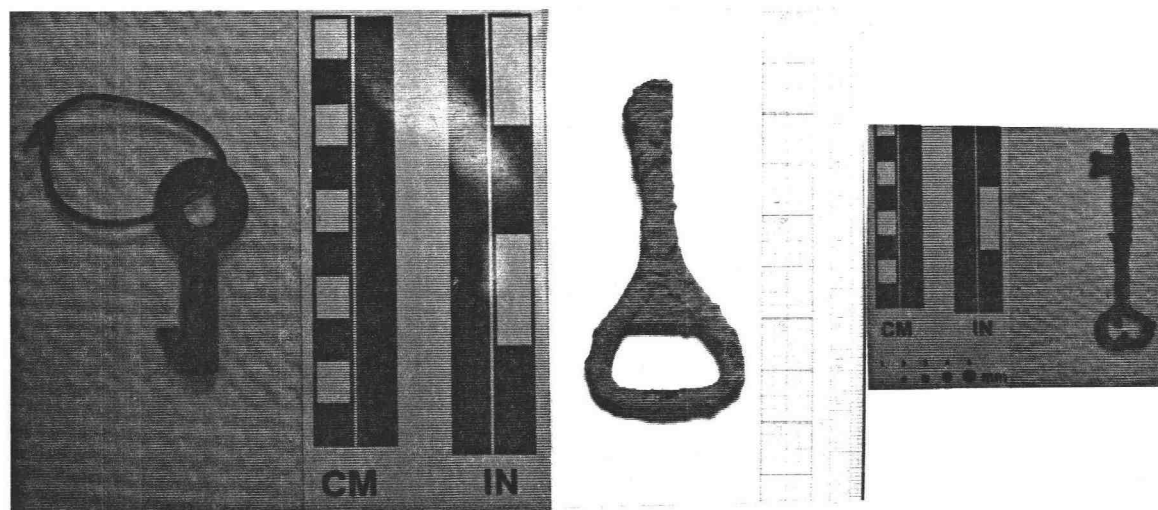


FIGURE A-9. Types of keys (9a,b,c).

### *Architecture*

Nearly 40% of the total number of artifacts (not including concrete fragments and chunks which were also common but not collected) that were recovered are associated with the Battery Freeman superstructure. The following architectural items are listed in order of decreasing number: nails and nail fragments, bricks and brick fragments, orange flat clay tile fragments, glass tubing, concrete samples, flat glass, sheet lead fragments, red clay drain tile fragments (Figure A-10), miscellaneous nuts, bolts, screws, wire (Figure A-11), porcelain insulators, slate fragments, hinges (Figure A-12), and fragments of red paint.

Since most of the artifacts are associated with the battery structure, I have summarized the artifacts that are associated with the interior and exterior finish as follows: 50 sheet-lead fragments (possibly fragments of some of the larger metal objects); electrical wiring (both insulated and uninsulated); copper wiring; fuses; switch plate, Unit 1, level 8; door hinges and latches (Figure A-8). The sixteen linoleum fragments were recovered from the ditch and are most likely associated with the post-abandonment period.

**Nails:** Essentially three types of nails are identified: machine cut square nails; wire-drawn nails and; one hand-wrought square nail (Figure A-13). Hand-wrought nails were manufactured well into the 1900s, especially in remote areas or where supply was a challenge. Mercer (1924) attributes the continued use of wrought nails simply as one of individual's preference. However, because of the

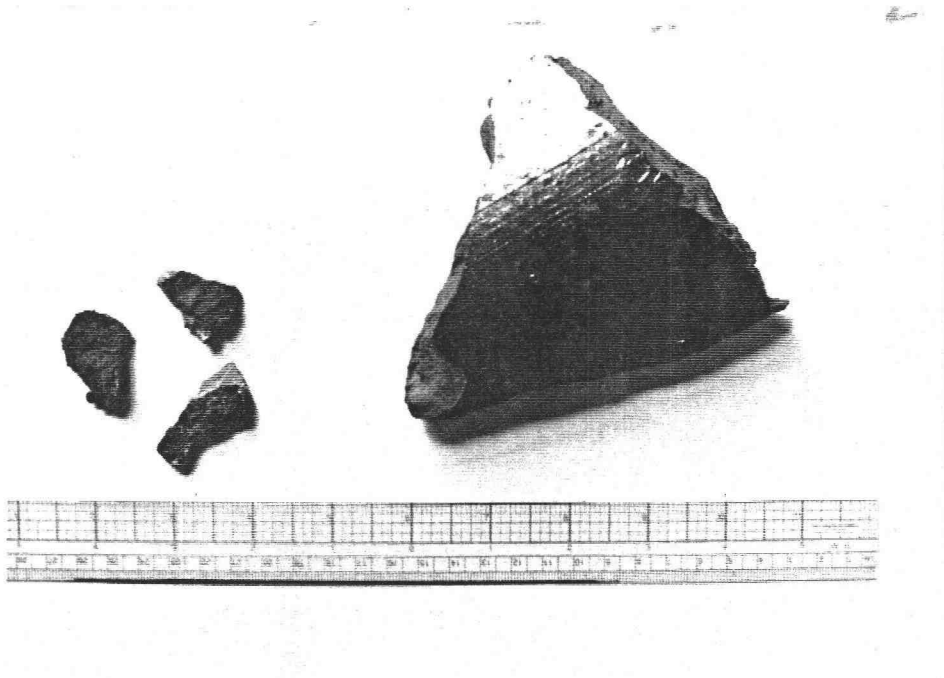


FIGURE A-10. Examples of architectural artifacts (red clay tile fragments).

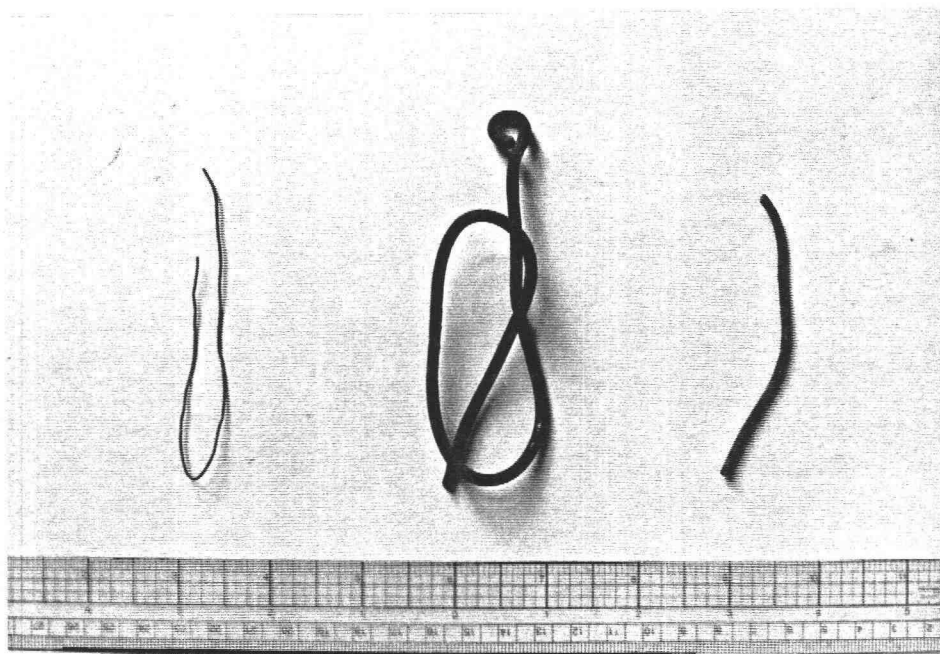


FIGURE A-11. Examples of architectural artifacts (wire).



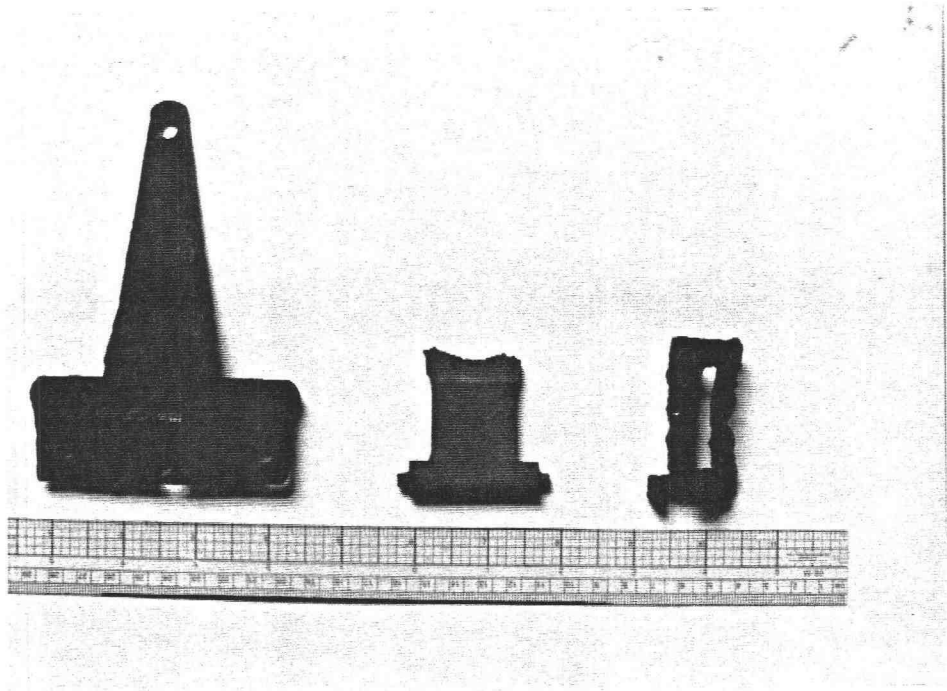


FIGURE A-12. Examples of architectural artifacts (hinges)

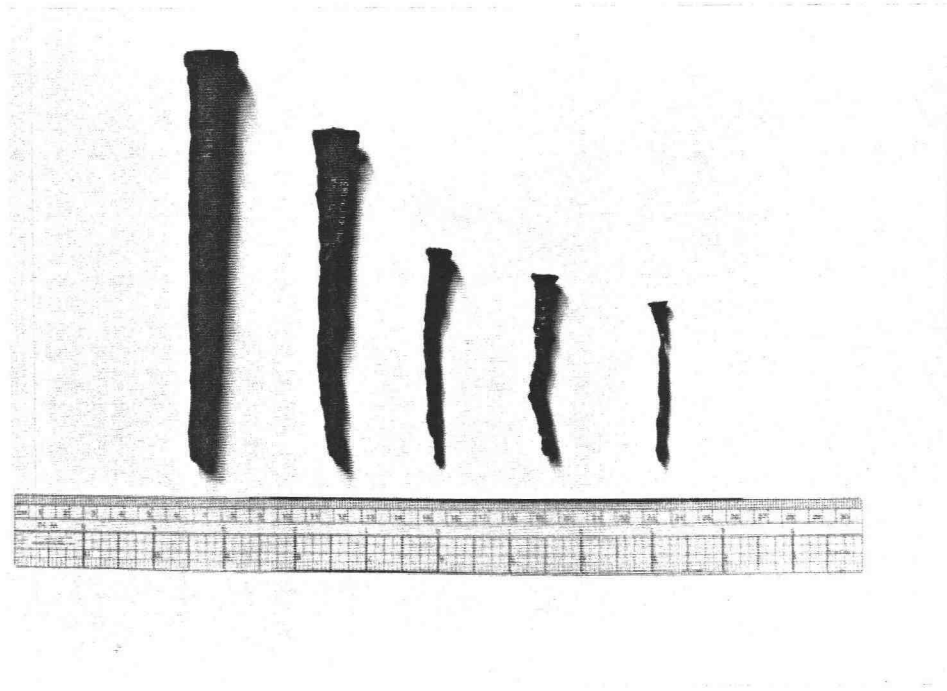


FIGURE A-13. Types of nails.

large number of machine cut nails, it is possible that the hand-wrought nail is a remnant of the earthwork structure. Figure A-14 provides the nail distribution and is accompanied by Table A-3 which summarizes the nails within the fort's interior.

Wire nails were developed during the 1880s when the price of steel was low and became a fad in the 1890s. By the end of the 19th century, wire nail production exceeded cut and wrought nail production (Priess, 1974:22). The wire-drawn nails were most likely used as finishing nails for the interior walls of the Battery Freeman structure.

**TABLE A-3: SUMMARY OF NAILS WITHIN THE INTERIOR**

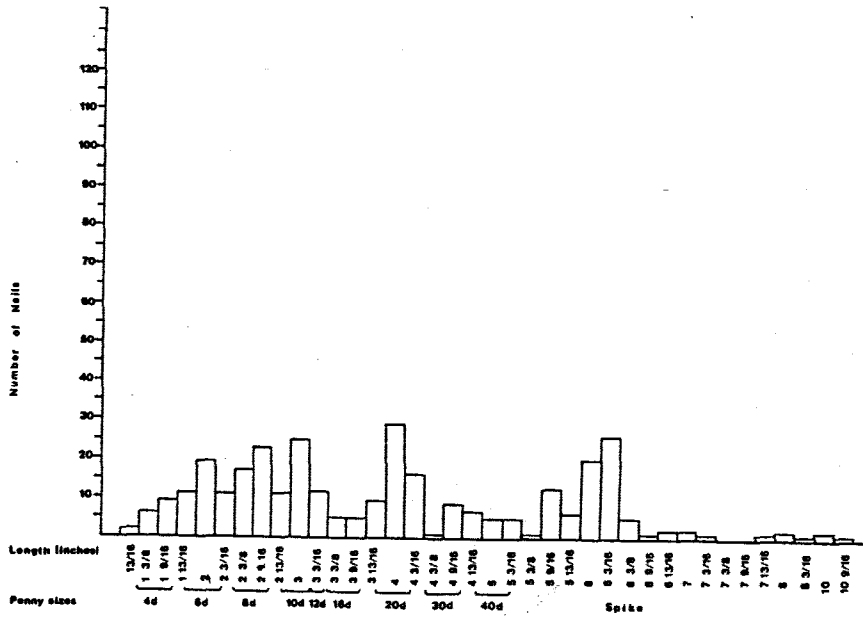
Machine Cut Square Nails	303	38%
Square Nail Fragments	265	33%
Brass Square Nail, Handwrought	1	1%
Wire Drawn Nails	98	12%
Wire Drawn Nail Fragments	87	11%
Unidentifiable Nail Fragments	43	5%
TOTAL	802	100%

**Bricks:** Approximately 300 red brick and/or brick fragments were recovered and are most likely associated with the incinerator feature. See Plate 1 for the distribution of bricks throughout the interior. A few whole bricks were collected and measured 205 mm x 98 mm x 58 mm. Several of the brick fragments are etched "...DEN" which may be associated with the "HIDDEN" brick manufacturing company. According to Gurcke (1987), the Hidden brick company of Vancouver, WA, continues to operate soft-mud brick machines in the Northwest. Prior to the mid-19th century, most bricks were made by hand in wooden or iron clad molds. Figure A-15 shows examples of some of the brick fragments.

**Orange Flat Clay Tile Fragments:** Nearly 200 clay tile fragments were uniformly distributed within the test units and were associated with either the battery vent pipes or functioned as drainage pipes. The fragments are orange and are either smooth on both sides or smooth on one side and grooved on the opposite.

**Concrete, mortar and slate samples:** Sixty-nine concrete samples and ten mortar fragments were collected (Figure A-16). A small sample of these chunks of concrete and mortar are possibly remnants of the Battery Freeman superstructure. Also, some of the concrete may be fragments of the battery parade ground. The slate fragments are associated with the mining casemate.

OR-CLT-1  
Square Nail Length Distribution



OR-CLT-1  
Round Nail Length Distribution

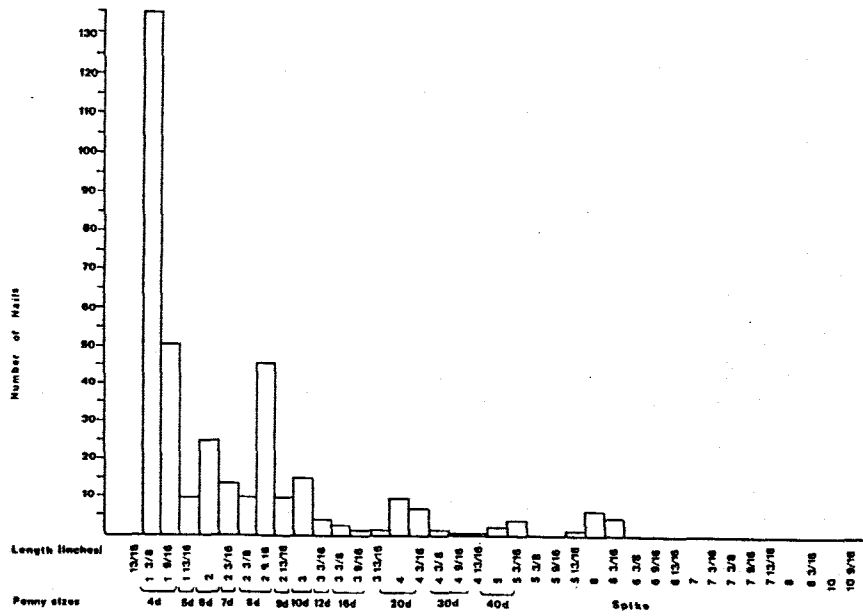


FIGURE A-14. OR-CLT-1 nail distribution.

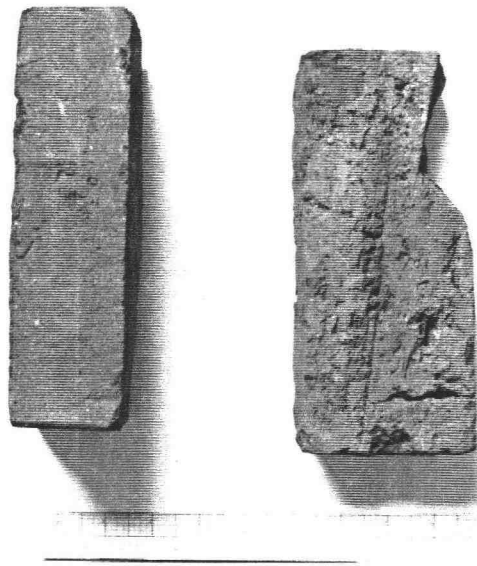


Figure A-15. Brick Fragments.

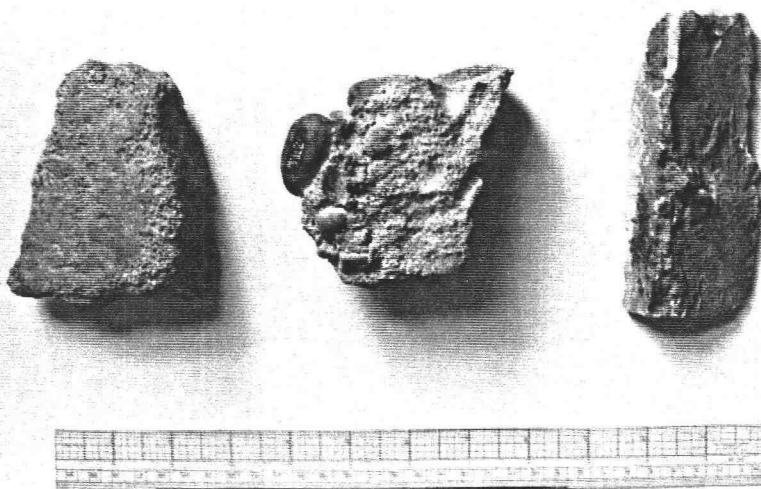


FIGURE A-16. Examples of concrete and mortar.

Glass tubing: The hollow glass tube fragments range in length from a couple of millimeters to 200 mm and have been cracked at both ends (Figure A-17). The glass tube fragments were uniformly dispersed throughout the units, however, there were larger concentrations in Units 1, 2, 3, 9 and 12.

Although, glass tubing is categorized under *Architecture*, their specific function remains unknown. There are, however, a couple of possible functions that have been offered. A visitor on site of the 1989 excavation suggested that these glass tubes may have been filled with gas and would be cracked open during gas drills (Brauner personal communication). Another possible use of the glass tubing could have been for leveling guns (Rosenfeld personal communication) on the platform.

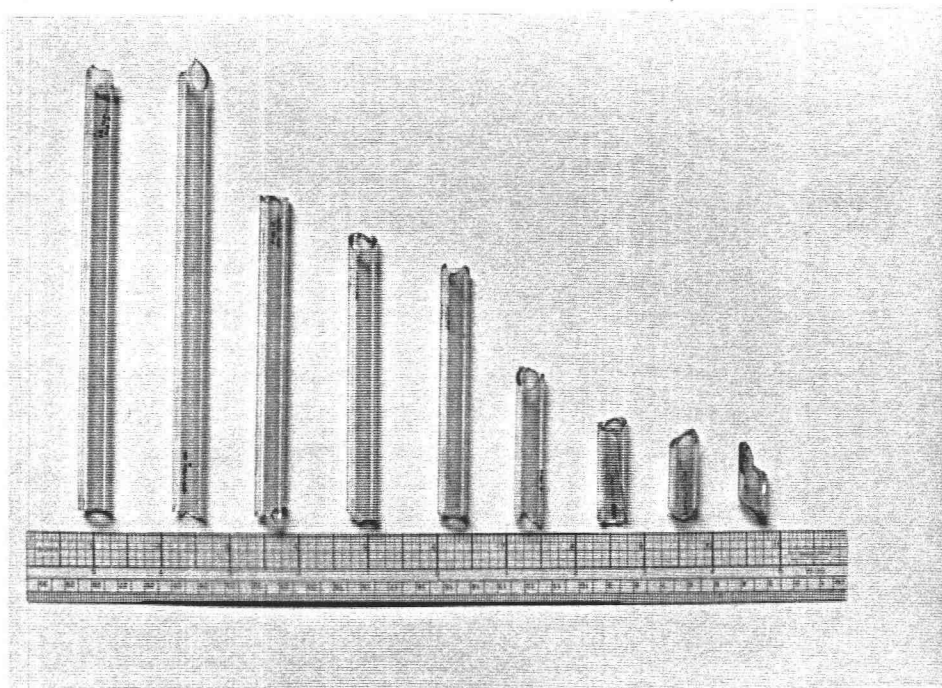


FIGURE A-17. Fragments of glass tubing.

Flat Glass: According to Jones and Sullivan (1989), one of two types of flat glass that are commonly recovered from archaeological sites is window glass. Sixty-four flat glass or window glass fragments were recovered mostly from Unit 3, level 8 and unit 6 level 9. The glass is clear with a green tint with thickness ranging from .0625 -.1875 inches.

Based on Roenke's (1978) study of 19th century window glass from sites in the Pacific Northwest, a large sample of glass is necessary before attempting to use it as a chronological tool. He also suggested that attempts at dating window glass should be restricted to such situation as association with a building when a possible date of construction is wanted.

Table A-4 summarizes the flat glass samples that are visually represented in Figure A-18. We can perhaps place some of these flat glass fragments into context

based on a letter to Colonel S.W. Roessler on March 31, 1907, "memo of work done for the Artillery for the 3 months ending March 31, 1907... 4 windows, broken at Battery Freeman" (NA, Box 469, p. 354).

TABLE A-4: FLAT GLASS

Thickness (in.)	N-sample	Percent
.0625	10	16
.070	7	11
.125	44	69
.1875	3	4
TOTAL	64	100

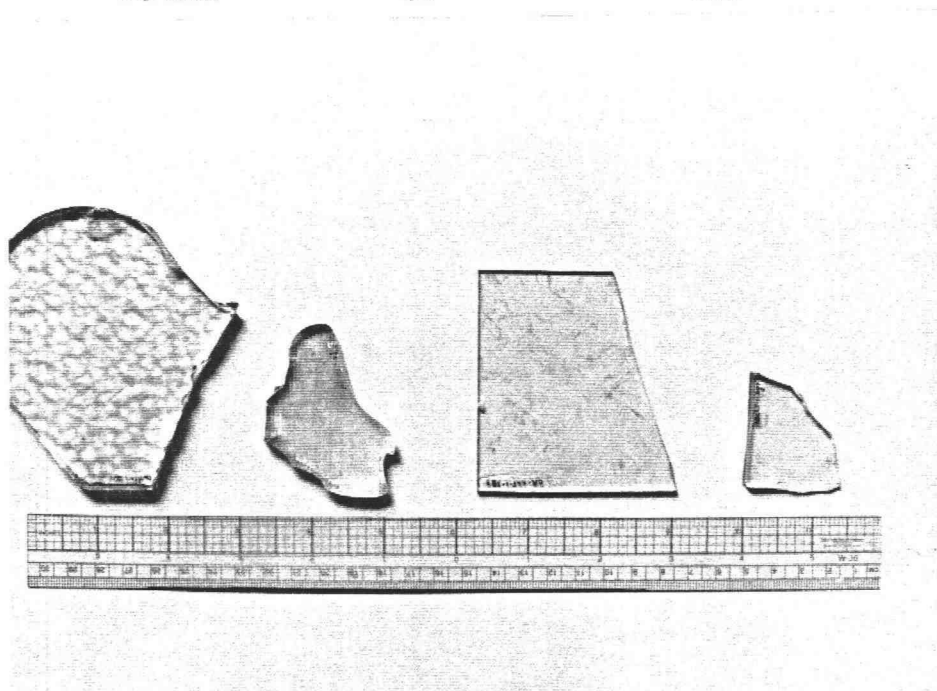


FIGURE A-18. Examples of flat glass.

Screws, nuts, bolts and washers: These items are again related to the constructional aspect of the battery (may include fasteners for gun mounts). The nuts and bolts range in size from a half an inch to couple of inches (Figure A-19). The washers are square or ringed and also measure from a half an inch to couple of inches. The screws range in length from two to four inches.

Insulators: Artifacts classified under porcelain insulators consist of three wire cleats, wire cleat fragments, split insulator fragments, a switch plate embossed with "BRYANT 2 AMP" diameter 56 mm, and unidentifiable fragments. The majority of these items were recovered from Unit 1, levels 3, 7 and 8 and functioned for electrical services. There was also one aqua glass insulator embossed "BROOKFIELD" that was recovered in ditch. Figure A-20 provides examples of insulators.

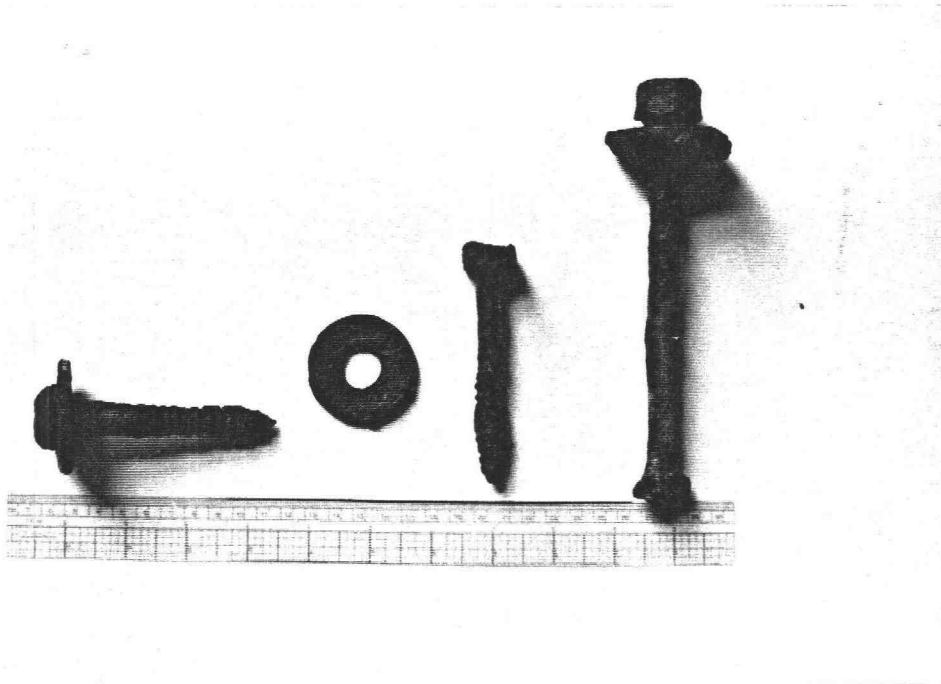


FIGURE A-19. Examples of nuts, bolts, and washers.

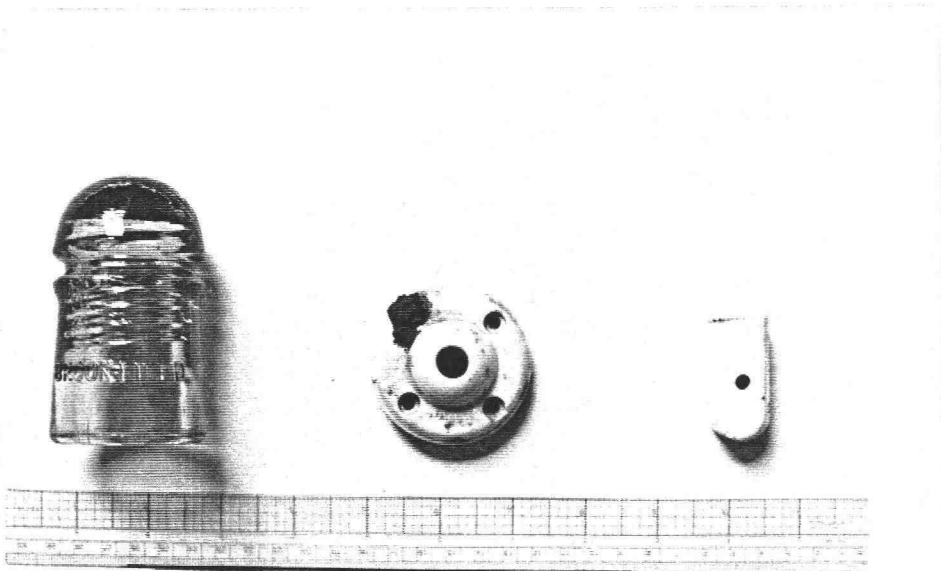
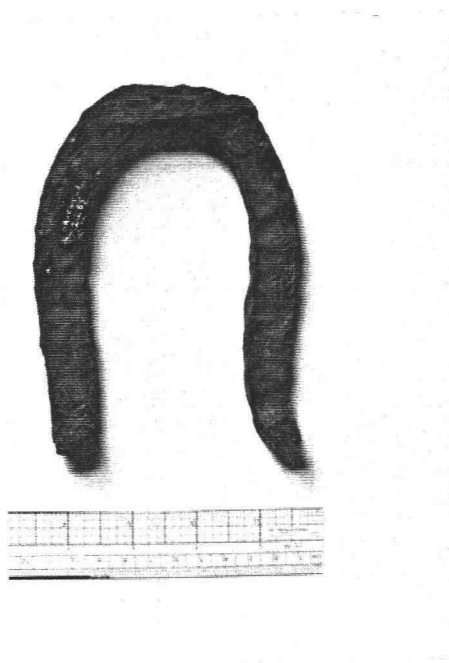


FIGURE A-20. Examples of insulators.

### *Transportation*

Artifacts such as a horseshoe, railroad spike, spark plug and plaster cast of a tire tread are categorized as transportation items.

A plaster cast was made of the tire treads which were unearthed from Unit 3, level 8 and are post-1900 in age. The horseshoe, found in Unit 1, level 8, appears to be the shoe for the front foot (Butler, 1990) (Figure A-21). The railroad spike was recovered from Unit 2, level 7.



**Figure A-21. Horseshoe.**

### *Commerce and Industry*

This category has the fourth largest number (12%) of artifacts. Artifacts within this category are clinkers and coal which appear to be associated with blacksmithing activities.

Clinkers and Coal: A total of 583 clinkers were dispersed throughout the test units, with the largest concentration in Unit 1 (incinerator feature). Clinkers are generally produced in high intensity fires associated with a blacksmith's forge (Bealer, 1976:134). There were also four pieces of coal, found in Unit 1, levels 2, 5 and 12. Coal was commonly used in the late 18th and early 19th centuries as a source of heat. Figure A-22 provides photographs of clinkers and coal.



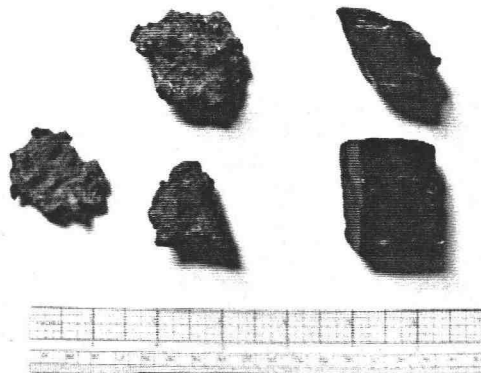


Figure A-22. Examples of clinkers and coal.

### *Group Services*

Only 2% of the artifacts are categorized within group services. These items include ammunition (including a primer wad with paper, Unit 1, level 12 and; magazine clip fragments, Unit 1, level 8), gun parts and military uniform miscellany. Seven types of cartridges were identified (Figure A-23) and are summarized below in Table A-5 and the following paragraphs.

**TABLE A-5. AMMUNITION**

HEADSTAMP	MANUFACTURER	N-Sample
FA	Frankford Arsenal	7
REM-UMC	Remington/Union Metallic Cartridge	3
UMC	Union Metallic Cartridge, Co.	1
USC	United States Cartridge Co.	1
H	Winchester Repeating Arms Co.	2
P	Peter's Cartridge Co. (absorbed by Remington)	1
U	Union Metallic Cartridge Co.	1

It is important to know that while most headstamps offer a date and a manufacturer's name, that several types of ammunition (i.e. blanks, dummies) commonly used old cases thus headstamp dates cannot be taken as manufacture dates (Hackley, Woodin, and Scranton, 1967).

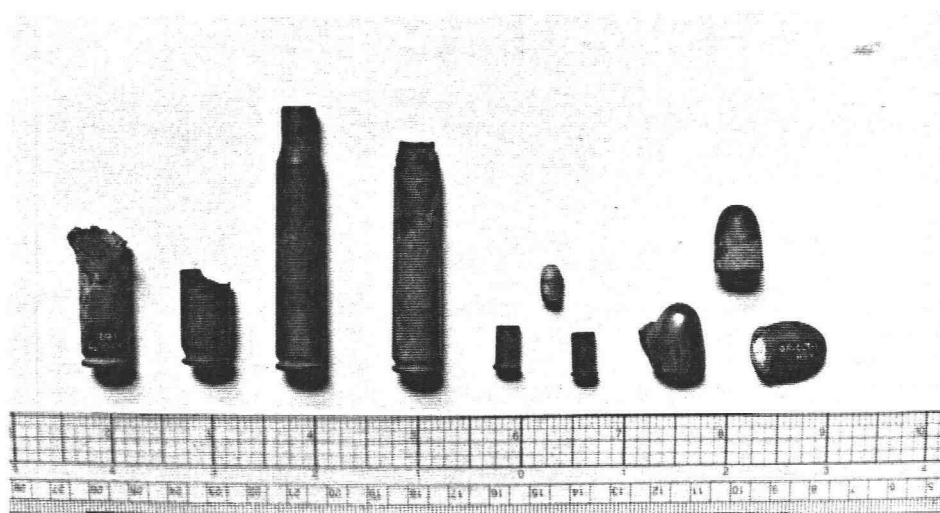


FIGURE A-23. Types of ammunition.

Seven .30 caliber cartridges have the headstamp "FA" which refers to the Frankford Arsenal Manufacturing Company from Philadelphia, PA. It was the only Government facility manufacturing small-arms ammunition during the early days of World War I and was to become the small-arms supplier for the armed forces (Hackley, Woodin and Scranton, 1967). Most of these cartridges have the following measurements: case length 64 mm, rim diameter 12 mm; headstamp "FA" with two sets of numbers. The "FA" refers to the manufacturer and as an example, the number "6" represents the month of June and the number "06" represents the year 1906. There were also five brass clip fragments for .30 caliber cartridges located from Unit 1, level 8.

Three .45 caliber cartridges headstamped "REM-UMC 18" are products of the Remington Arms-Union Metallic Cartridge Co., of Bridgeport, Connecticut. Since 1912, this company has been one of the largest commercial manufacturers of small-arms in the U.S. These cartridges were located in Unit 1, levels 2 and 6, and measure 12 mm at rim, with a 22 mm case length (Hackley, Woodin, and Scranton, 1967).

The two .30 caliber cartridges headstamped "UMC Co." are associated with Universal Metallic Company of Bridgeport, Connecticut. This company provided the U.S. Government with ammunition since the 1890s, and in 1911 it merged with Remington Arms (both of which were operated under the same management and ownership). The headstamp used after 1911 was "REM-UMC" (Hackley, Woodin, and Scranton, 1967).

There was one .30 caliber "USC Co.", with a 34 mm case length and a 11 mm rim diameter that was recovered from Unit 1, level 6 and; one .44 caliber rimfire cartridge with an "H" backstamp. Rimfire cartridges were first manufactured in France in 1845 and developed during the Civil War period (Barnes, 1969).

As discussed in Chapter 5, eight steel-jacketed .45 caliber bullets were recovered from Unit 1. These bullets measured: bullet length, 19 mm; diameter, 12 mm. There were also seven .22 caliber lead bullets, three grooved, recovered from Units 1, 2, 3 and 9, measuring 8 mm in length with a 9 mm diameter.

One of the few artifacts associated with the pre-1900 occupation are the two .50 caliber, minie balls (Figure A-24). These bullets are conical-shaped with three grooves and have partially hollow cavities. The bullets measure in diameter 1/2 inch and were recovered from Unit 1, levels 7 and 8. According to Edwards (1962), the minie balls were better sustained than with round bullets because "at nominal ranges, velocities were higher" (p. 429). The minie balls were the preferred cartridge for military use from 1855 to 1865 (Dixie, 1990).

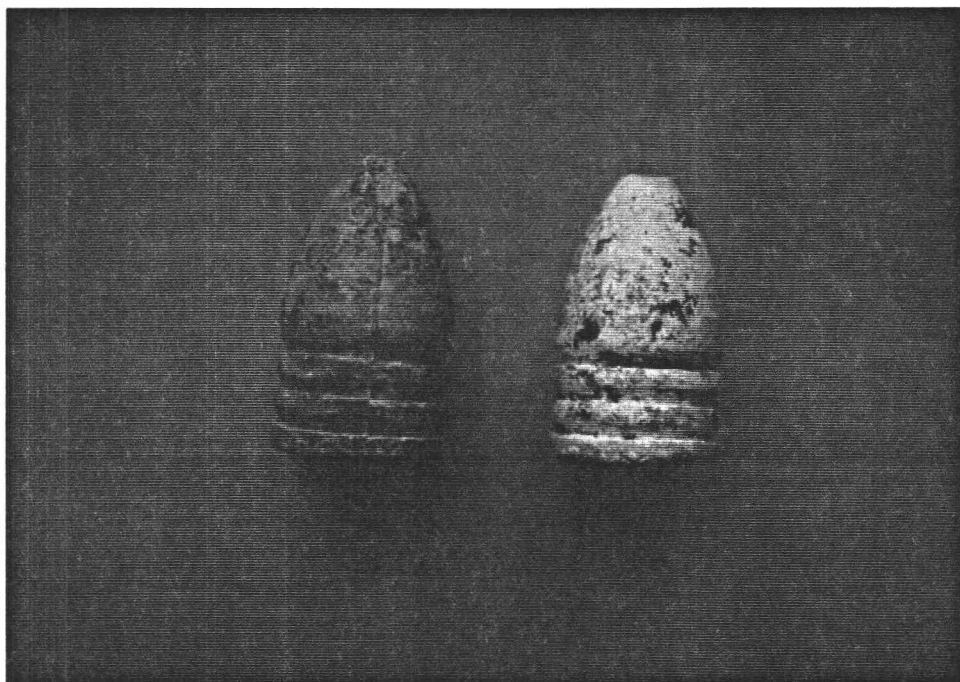
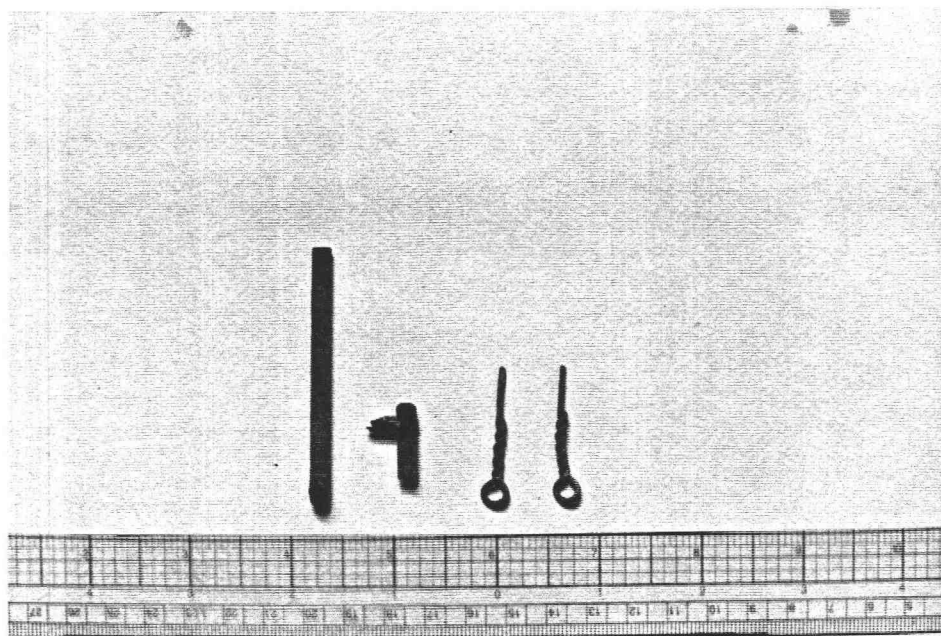


FIGURE A-24. Minie balls (diameter = 0.5").

Other artifacts that pre-date 1900 are friction primer pins. Friction primers were used to ignite powder charges in guns. A total of twenty-four cannon friction primer pins were recovered (most of which were found in Unit 9, bulkhead feature). There were also nine friction primer brass tubes, length 65 mm with a 5 mm diameter and; two complete friction primers (Figure A-25).



**FIGURE A-25.** Friction primers and pins.

**Gun Parts:** A front pintle mount, measuring 1 feet and 1/2 inches by 1 feet and 1/2 inches was recovered from Unit 9, level 7 (Figure A-26). A front pintle as defined by Hines and Ward (1910) is "a coast carriage where its axis of rotation is at or near its front end... where it traverses about a point in front of its center" (p. 28). Hanft (1980) mentioned that the Chief of Engineers provided some money in 1987 for a new wooden platform for the 15-inch Rodman Smoothbore and that a new platform was built on the left face of the earthwork for a front pintle.

**Buttons:** (Figure A-27). A plain shield button embossed "WATERBURY BUTTON CO." is a product of the Waterbury Button Company and was located in Unit 1, level 8. A four hole metal button with "ARMY" backstamp was recovered from Unit 1, level 9. This button is a product of the Army and Navy Button Co. of Waterbury, Connecticut, manufacturer of military buttons since the 1860s.

**Insignia:** A crossed-cannon field artillery insignia was recovered from the ditch (Figure A-28). According to Kerrigan (1967), the two light field guns crossed in gold represent the Civil War Period, and were used in the Army through World War II. There was also one brass collar pin "U.S.", recovered from Unit 6, level 8 (Figure A-29).

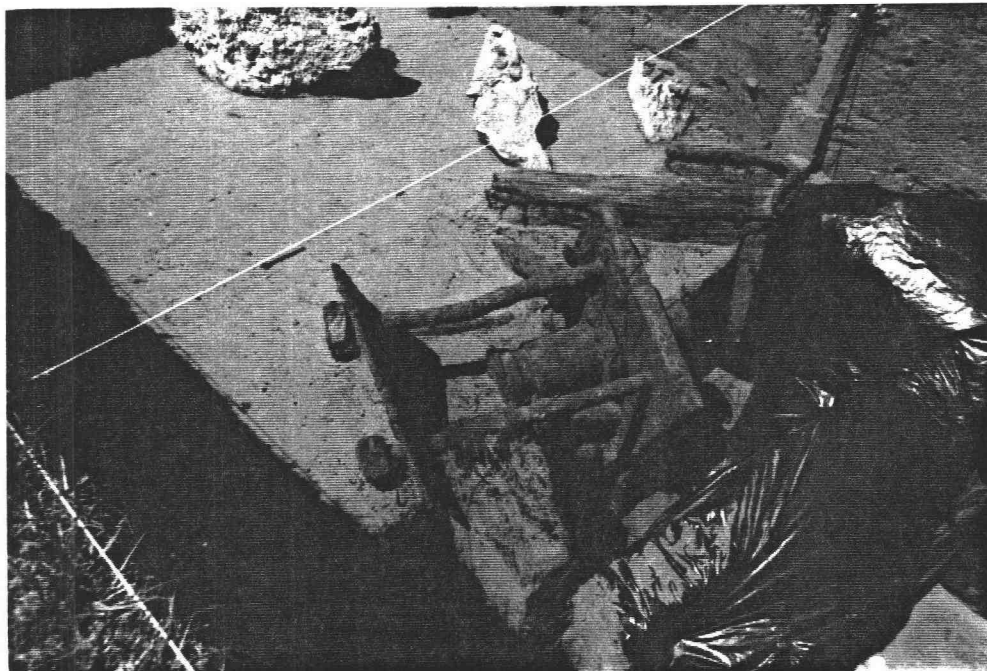


FIGURE A-26. Front pintle mount.

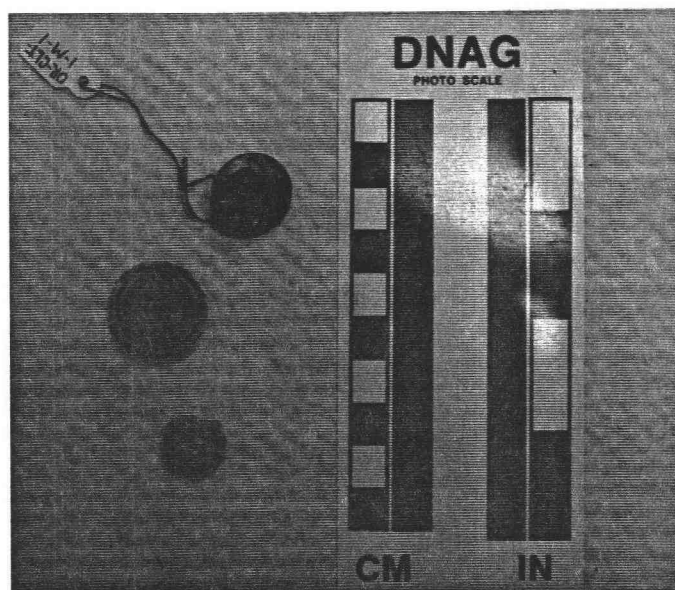


FIGURE A-27. Types of buttons.

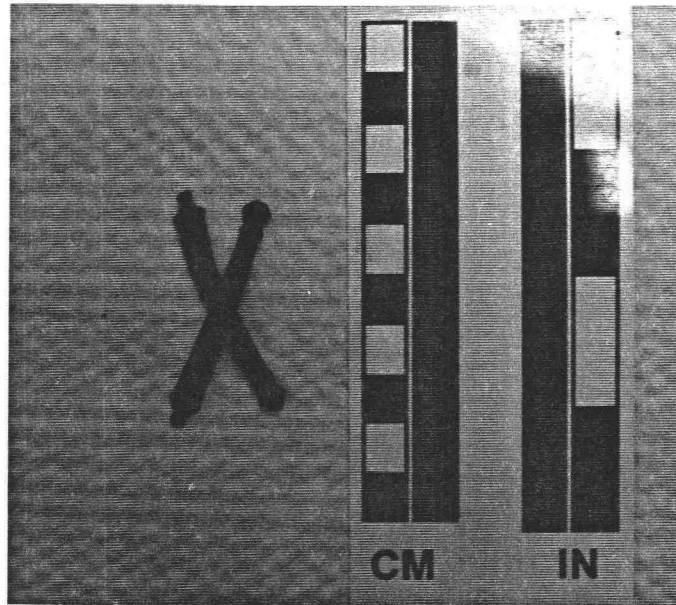


FIGURE A-28. Crossed cannon insignia.

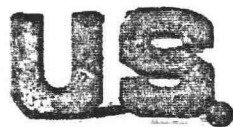


FIGURE A-29. Brass collar pin (actual size).



*Unknowns*

Quite typically, items cannot be identified and/or the function cannot be determined. There were a large number of artifacts that could not be typed by their function and were thus classified as unknowns. This category comprises the third largest number of artifacts. Items considered as unknowns include: chrome half rings, metal attachment rings, oval wire ring handles (Figure A-30), unidentifiable lead fragments, paper fragments with print and a bulk of unidentifiable sheet metal fragments.

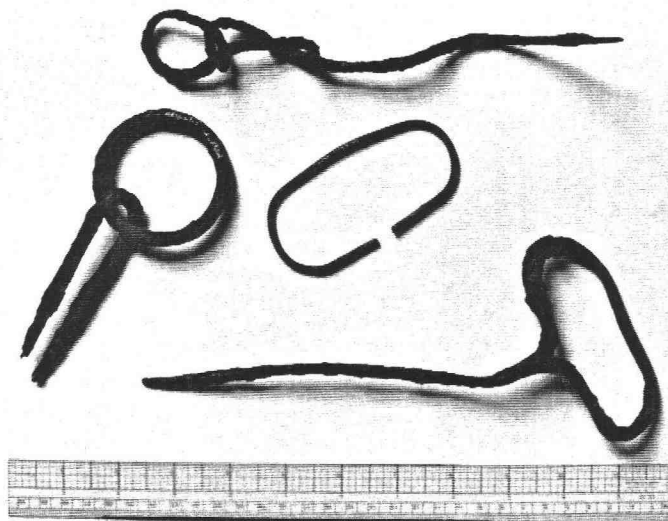


FIGURE A-30. Examples of oval wire ring handles.