

## AN ABSTRACT OF THE THESIS OF

BRIAN W. KRAMER for the degree of MASTER OF SCIENCE  
in CIVIL ENGINEERING presented on April 12, 1993

Title: A ROAD DESIGN PROCESS FOR LOW VOLUME RECREATION  
AND RESOURCE DEVELOPMENT ROADS.

Abstract approved: \_\_\_\_\_  
Robert D. Layton

This study presents a rational process with supporting data to establish appropriate road design controls, criteria, and standards for low volume recreation and resource development. Much of the information presented can be used to supplement design data presented in a National road design policy published by the American Association of State Highway Transportation Officials, A Policy on Geometric Design of Highways and Streets, 1990.

A transportation development process requiring interdisciplinary analysis is developed with a detailed example. This process is necessary to assure that transportation facilities meet land management objectives with minimum environmental impact.

The location of recreation and resource development routes is addressed in detail. Proper route location is a key element in providing a safe road with minimum maintenance and operational costs while yielding minimal environmental impacts.

© Copyright by Brian W. Kramer  
April 5, 1993

All Rights Reserved

**A Road Design Process  
for Low Volume  
Recreation and Resource Development  
Roads**

**by**

**Brian W. Kramer**

**A THESIS  
submitted to  
Oregon State University**

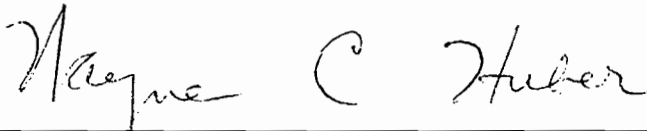
**in partial fulfillment  
for the degree of  
Master of Science**

**Completed April 12, 1993  
Commencement June 1993**

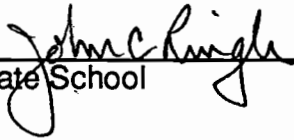
APPROVED:



\_\_\_\_\_  
Professor of Civil Engineering in charge of major



\_\_\_\_\_  
Head of Department of Civil Engineering



\_\_\_\_\_  
Dean of Graduate School

Date thesis is presented April 12, 1993

Typed by Brian W. Kramer for Brian W. Kramer

## Table of Contents

1 INTRODUCTION	1
1.1 Purpose of Study	1
1.2 Scope	1
2 SPECIAL PURPOSE ROAD FUNCTIONS, DESIGN CONTROLS, AND CRITERIA	3
2.1 Functions	3
2.2 Road Design Controls and Criteria	3
3 ROAD DESIGN	18
3.1 Design Elements and Standards	18
3.2 Sight Distance	18
3.3 Horizontal and Vertical Alignment Control	23
3.4 Road Templet Design Standards	49
3.5 One-lane Road Intersection Designs	54
3.6 One-Lane Road Turnouts	55
3.7 Road Drainage	60
4 RESOURCE TRANSPORTATION PLANNING	66
4.1 Resource Area Transportation Planning	66
4.2 Area Transportation Planning	67
5 ROAD LOCATION	70
5.1 Required Resources for Effective Road Location	70
5.2 Road Location Procedures	73
6 CONCLUSION	96
7 RECOMMENDATIONS	97
8 BIBLIOGRAPHY	98
APPENDIX	100

## Table of Contents

1 INTRODUCTION	1
1.1 Purpose of Study	1
1.2 Scope	1
2 SPECIAL PURPOSE ROAD FUNCTIONS, DESIGN CONTROLS, AND CRITERIA	3
2.1 Functions	3
2.2 Road Design Controls and Criteria	3
3 ROAD DESIGN	18
3.1 Design Elements and Standards	18
3.2 Sight Distance	18
3.3 Horizontal and Vertical Alignment Control	23
3.4 Road Templet Design Standards	49
3.5 One-lane Intersections	54
3.6 One-Lane Turnouts	55
3.7 Road Drainage	60
4 RESOURCE TRANSPORTATION PLANNING	66
4.1 Resource Area Transportation Planning	66
4.2 Area Transportation Planning	67
5 ROAD LOCATION	70
5.1 Required Resources for Effective Road Location	70
5.2 Road Location Procedures	73
6 CONCLUSION	96
7 RECOMMENDATIONS	97
8 BIBLIOGRAPHY	98
APPENDIX	100

## List of Figures

Figure 1. Forest Service Road Design Decision Procedure.	5
Figure 2. Tractor-Trailer-Train Combinations.	11
Figure 3. Logging Equipment.	11
Figure 4. Safe Passing Sight Distance.	23
Figure 5. Disjointed Sight Effect.	24
Figure 6. Horizontal and Vertical Alignment Balance.	24
Figure 7. Non-Geometric Horizontal Alignment.	25
Figure 8. Geometric Horizontal Alignment.	25
Figure 9. Superelevation for Spiraled Curves.	30
Figure 10. Sight Distance on a Horizontal Curve.	33
Figure 11. Overhang Clearance Plotting.	39
Figure 12. Position of Log Yarder Tower on Road Section.	39
Figure 13. Cresting Vertical Curve.	41
Figure 14. Crest Vertical Curve Road Surface Sight Distance.	43
Figure 15. Sag Vertical Curve Sight Distance.	43
Figure 16. Vertical Curve Low Point Over Stream Channels.	44
Figure 17. Example Plan View of a Switchback Curve.	48
Figure 18. Profile and Grade Through a Switchback Curve.	49
Figure 19. Road Surface Superelevation on a Switchback.	49
Figure 20. Road Templet Terminology.	50
Figure 21. Road Surface Templets.	52
Figure 22. Intersection Geometry for Two-way Haul.	54
Figure 23. Intersection Geometry for One-way Haul.	55
Figure 24. Common Grade at Intersections.	55
Figure 25. Turnout Design Geometry.	57
Figure 26. One-Lane Road Turnout Spacing.	59
Figure 27. Ditch Relief Culvert Design	61
Figure 28. Culvert Installed Without Camber.	61
Figure 29. Skewed Culvert.	62
Figure 30. Culvert Length Computations.	63
Figure 31. Improper Culvert Outlet Design.	64
Figure 32. Culvert Down Spout and Energy Dissipater.	64
Figure 33. Example Drain Dip Design Profile.	65
Figure 34. Levels of Resource Transportation Planning.	66
Figure 35. Resource Area Transportation Plan Example.	67
Figure 36. Cactus Mountain Project Area Transportation Plan.	68
Figure 37. Cactus Mountain Project Area Harvest Plan.	69
Figure 38. Non-Geometric Road Design Location.	72
Figure 39. Geometric Road Design Location.	73
Figure 40. Location on Centerline and at Grade-out.	76
Figure 41. Grade Line to Establish a Control Point.	78
Figure 42. Horizontal Curve Information for Road Location.	79
Figure 43. Curve Location with an Inaccessible P.I.	80
Figure 44. Switchback Curve Locations.	81
Figure 45. Profile Grade Through a Switchback Curve.	82
Figure 46. Superelevation on a Switchback Curve.	82
Figure 47. Proper Switchback Curve Location.	84
Figure 48. Improper Switchback Curve Location.	85
Figure 49. Grade Line Location Through a Draw.	87
Figure 50. Improper Grade Line Location Through a Draw.	88
Figure 51. Road Location Adjacent to a Stream.	89
Figure 52. Proper Grade Line Location Around a Narrow Ridge.	90
Figure 53. Improper Grade Line Location Around a Ridge.	91
Figure 54. Tractor or Skidder Log Landing Location.	92

Figure 55. Skyline Logging Landing Location.	92
Figure 56. Intersection Location for Two-Way Log Haul.	93
Figure 57. Intersection Location for One-Way Log Haul.	94
Figure 58. Stream Crossing Location.	95



### List of Tables

Table 1 Example Design Vehicles.	7
Table 2. Types of Design Vehicle.	8
Table 3. Design Vehicle Dimensions.	9
Table 4. Minimum Turning Radii of Design Vehicles.	10
Table 5. Design Speed for Low Volume Roads.	12
Table 6. Traffic Service Level Descriptions.	14
Table 7. Braking Tractive Coefficients.	20
Table 8. Stopping Sight Distance on Two Lane Roads.	21
Table 9. Minimum Stopping Sight Distance.	21
Table 10. Minimum Passing Sight Distance on Two-Lane Roads.	22
Table 11. Tractive Coefficients for Various Road Surfaces.	28
Table 12. Super Elevation Runoff.	31
Table 13. Super Elevation Runoff Distance.	32
Table 14. Safe Stopping Distance for Trucks.	34
Table 15. Curve Widening for Traffic Service Levels.	37
Table 16. Curve Taper Values.	40
Table 17. Steep Road Grade Design Standards.	46
Table 18. Surface Aggregate Specifications.	47
Table 19. Lane Widths.	50
Table 20. Lane Width for Two-Lane Roads.	51
Table 21. Two-Lane Width, Off-Highway Log Trucks.	51
Table 22. Lane Widths for One-Lane Roads.	51
Table 23. Shoulder Widths.	53
Table 24. AASHTO One-Lane Road Turnout Design Dimensions.	56
Table 25. One-Lane Road Turnout Requirements.	58
Table 26. One-Lane Road Turnout Dimensions.	58
Table 27. Drain Dip Design and Construction Staking Data.	65
Table 28. Traffic Analysis and Traffic Service Levels.	101

A ROAD DESIGN PROCESS  
FOR LOW VOLUME  
RECREATION  
AND  
RESOURCE DEVELOPMENT  
ROADS

**1 INTRODUCTION**

**1.1 Purpose of Study**

The purpose of this study is threefold. First, to present a rational procedure to establish adequate roads design controls, criteria, and standards for low volume special purpose, recreation and resource development roads, while considering driver safety and environmental impacts. Second, to document additional necessary design controls, criteria, and standards for low volume, special purpose roads as described in the road design policy published by the American Association of State Highway and Transportation Officials, *A Policy on Geometric Design of Highways and Streets (1)*, known as the AASHTO "Green Book". Third, to describe the transportation planning process and route location procedures that are unique in development of special purpose recreation and resource development roads.

**1.2 Scope**

The AASHTO Green Book (1) does not adequately address many necessary geometric design considerations required to provide safe, economical, environmentally acceptable, and aesthetically pleasing recreation and resource development roads. A road designer using that publication is not provided with sufficient controls, criteria, and elements of design for many specific road design situations encountered in the development of low volume, special purpose recreation and resource development roads.

To assure that resource land management objectives are adequately met in the design of special purpose roads, a rational planning process must be followed from the development of a road during transportation planning through road design. The development of road design controls and criteria are established during transportation planning. Road design standards are established and verified during route location and road design. A documented process is presented to accomplish this objective.

Documented design controls, criteria, and standards are presented from the U.S.D.A. Forest Service, *FSH 7709.56, Road Preconstruction Handbook (2)*, referenced as the "U.S.F.S Preconstruction Handbook". This publication describes a rational process for developing this necessary road design information. Additional

information is presented from other sources. Road surfacing design, pavement management, the hydraulic and strength design of culverts, and road maintenance management are not addressed.

Comprehensive transportation planning is often necessary to insure that resource transportation development will meet required land management objectives involving many complexed resource issues. A procedure is presented to accomplish this with an example recreation and resource development transportation plan.

Route location is often a critical function in the development of special purpose roads. If a route is not properly located, the road may not serve the intended resource function and may generate significant environmental impacts. Of all the resource development activities, special purpose roads often generate the greatest impacts on the environment due to sediments from erosion and disruption of certain wildlife species. For these reasons route location procedures are presented in detail.

## **2 SPECIAL PURPOSE ROAD FUNCTIONS, DESIGN CONTROLS, AND CRITERIA**

The classification of roads into different operational systems, functional classes or geometric types, is necessary for communication among engineers, resource specialists, administrators, and the general public. Design controls, criteria, elements, and standards are developed and discussed to enhance the design efficiency of special purpose roads.

### **2.1 Functions**

In the AASHTO Green Book (1), special purpose roads are defined as resource development and recreational roads. It is stated that special purpose roads and their design are different from the design of standard highways described in the publication. The types of vehicles operating on recreation roads could include motor homes, automobiles, motorcycles, and four-wheel drive vehicles. The types of vehicles operating on resource development roads can include large slow moving mining and logging vehicles. Recreation and resource development roads are often designed for mixed traffic, recreation and resource development vehicles. Thus, special purpose roads are unique when compared to standard highways.

#### **2.1.1 Systems and Classifications**

The classification of roads as arterial, collector, and local service also applies to special purpose roads. The classification of resource development and recreation roads by different operational systems, functional classes, or geometric types is necessary for communication among engineers, other resource personnel, administrators, and the general public. Functional classification, the grouping of roads by the character of service they provide, was developed for transportation planning (1).

### **2.2 Road Design Controls and Criteria**

Design controls, criteria, elements, and standards for special purpose roads must follow a comprehensive, rational development process to insure that a designed road meets required resource management objectives. The U.S.D.A. Forest Service has implemented a procedure to accomplish this objective nationwide, within the National Forest system. A flow chart of this process is illustrated in Figure 1. In Figure 1, the terms design criteria, elements, and standards are analogous to the AASHTO Green Book (1) definitions of design control, criteria, and elements. Definitions of the terminology used in Figure 1. follow:

**Design Criteria** - The requirements derived from management area direction, such as safety requirements and traffic characteristics that govern the selection of elements and standards for a road or section of road.

**Design Elements** - The physical characteristics of a road, such as number of traffic lanes, shoulders, slope, curve widening, and pavement structures that, when combined, comprise the planned facility.

**Design Standards** - The definitive dimensions of individual design elements, such as a 12 ft travel way, 2 ft shoulders, 1:1 cut slope, or 0.5 ft of crushed aggregate surfacing.

**Maintenance Levels** - The level of service provided, and maintenance required for a specific road, consistent with road management objectives and maintenance criteria.

**Maintenance Plans** - An annual proposal for road maintenance work that is based on work described and estimated in a maintenance prescription.

**Management Area** - An area with similar management objectives and a common management prescription.

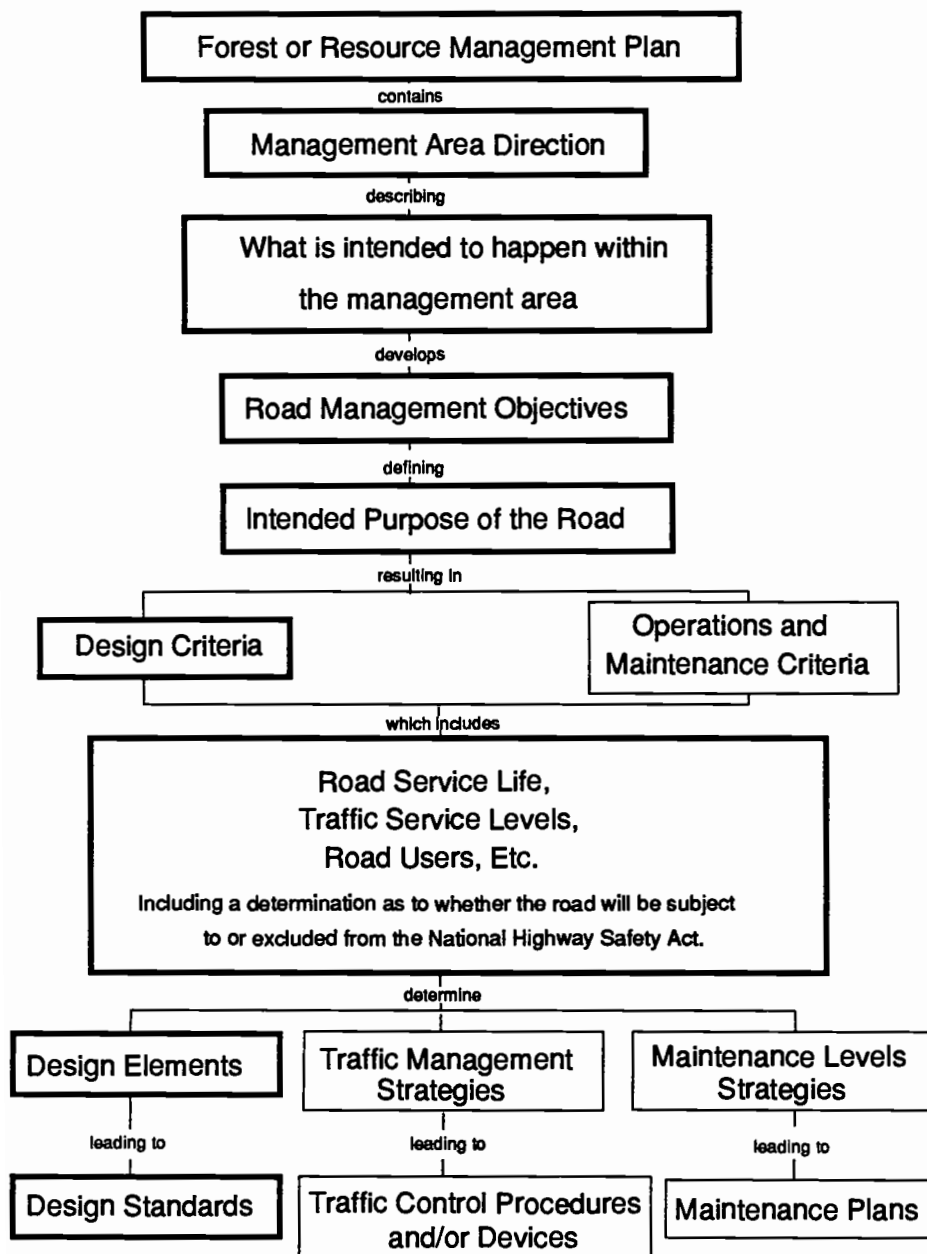
**Management Area Direction** - Direction from a forest plan that specifies activities for implementation, environmental quality requirements, natural and depletable resource requirements, and mitigating measures to achieve management goals for a specific management area.

**Objective Maintenance Criteria** - Objective maintenance level to be assigned to a future date considering future road management objectives, traffic needs, budgetary constraints, and environmental concerns. The objective maintenance level may be the same, higher, or lower than the operational maintenance level.

**Road Management Objectives** - Definitive description of the intended purpose of an individual road based on management area direction, access management, operation criteria, and maintenance criteria.

**Service Life** - The length of time that a transportation facility is expected to provide a specified service.

**Traffic Management (Strategies)** - Described methods employed on forest development roads to control traffic. The five applied strategies are to encourage, accept, discourage, eliminate, or prohibit traffic.



NOTE:  Flow path through the decision process.

**Figure 1. Forest Service Road Design Decision Procedure.**

It is often necessary to evaluate factors for low volume recreation and resource development roads that are not addressed in normal highway design situations. Examples of these factors are: impacts on wildlife, visual resource management, fisheries, recreation, and resource development opportunities. Thus, transportation planning for special purpose roads can require a high degree of interdisciplinary coordination to establish appropriate road design criteria and standards that meet resource management objectives and requirements.

### **2.2.1 Road Design Controls**

In this section, the characteristics of vehicle traffic that act as criteria for the optimization or improvement in the design of special purpose roads is discussed. The discussion includes design vehicle performance and characteristics, types of design vehicles, driver performance, design traffic volume, and road design speed.

#### **2.2.1.1 Design Vehicle Performance and Characteristics**

Vehicle performance and characteristics must be considered in determining the many design standards used in traffic analysis and road design. It is necessary to determine the safe stopping distance, safe passing distance, minimum vehicle turning radius, etc. when designing a road. Sources of information for the analysis of vehicle performance are: Shadler, S., H. Emery, and H. Brewer (3); Brewster and Rice (4); Campbell (5); Wong (6); Manning and Kilareski (7). Vehicle characteristics such as wheel width, wheel base, gross vehicle weight, axle weights, and overhanging components are important in the design of road geometry dimensions, road surface structure strength, bridge and culvert vehicle loading.

A design vehicle is a vehicle that determines the minimum standard for a particular design element such as lane width, minimum radius horizontal curve and shortest vertical curve, and maximum grades, etc. No single vehicle controls standards for all design elements of a road (2). An example is a road on which passenger vehicles control elements related to sight distance and large, over highway legal weight resource development equipment controls road surface design, vehicle off-tracking, and bridge structural strength design.

During the design process, maximum and minimum standards for the type and configuration of vehicles planned to use the road must be analyzed. Each design element is analyzed to determine which vehicle type governs the standard for a particular element. Road surfacing design is not addressed. However, it is necessary to

determine design vehicle types and gross vehicle weights. This is required information for determining the proper design strength of road surfacing and road structures. Example design vehicles are in Table 1.

**Table 1. Example Design Vehicles.**

<b>Design Element</b>	<b>Possible Design Vehicles</b>
Stopping Sight Distance	Passenger car or pickup truck
Curve Widening	Lowboy or log truck
Gradient	Log truck or recreation vehicle
Bridge Design	Heavy logging equipment
Pavement Thickness Design for a Campground	Truck weight classification

A critical vehicle is normally the largest by weight, size, or unique configuration, whose limited use of a road is necessary to complete a planned activity (2). Examples of critical vehicles are; tractor trailers carrying construction equipment, large transport equipment carrying oil drilling equipment, and large logging equipment.

The design of a resource development road can include special provisions, operational considerations, or a combination of both to accommodate a critical vehicle. An example is temporary filling of ditches on designated inside curves to accommodate the off-tracking of a lowboy trailer. Vehicle tracking must be analyzed to determine whether or not this is a viable option in design.

#### **2.2.1.2 Design Vehicles**

The AASHTO Green Book (1) provides vehicle dimensions and minimum turning radii for three classes of vehicles; single unit vehicles, combination trucks, and recreation vehicles. It is assumed that these vehicles are traveling at less than 10 mph. These design vehicles are described in Table 2, vehicle dimensions are in Table 3, and minimum turning radii are in Table 4. The truck designation of WB identifies the length of wheelbase of the vehicle.



**Table 2. Types of Design Vehicle.**

<b>Design Vehicle Type</b>	<b>Symbol</b>
<b>Single Unit Vehicles</b>	
Passenger car	P
Single unit truck	SU
Single unit bus	BUS
Articulated bus	A-BUS
<b>Combination Trucks</b>	
Intermediate semitrailer	WB-40
Large semitrailer	WB-50
"Double Bottom" semitrailer, full trailer	WB-60
Interstate semitrailer	WB-62
Interstate semitrailer	WB-67
Triple semitrailer	WB-96
Tumpike double semitrailers	WB-114
<b>Recreation Vehicles</b>	
Motor home	MH
Car and camper trailer	P/T
Car and boat trailer	P/B
Motor home and boat trailer	MH/B

Table 3. Design Vehicle Dimensions.

Design Vehicle	Dimensions (ft)										
	Overall (ft)			Overhang (ft)			Other Dimensions (ft)				
	Height	Width	Length	Front	Rear	WB <sub>1</sub>	WB <sub>2</sub>	WB <sub>3</sub>	WB <sub>4</sub>	S	T
P	4.25	7	19	3	5	-	-	-	-	-	-
SU	13.5	8.5	30	4	6	20	-	-	-	-	-
BUS	10.5	8.5	40	7	8	25	-	-	-	-	-
A-BUS	13.5	8.5	60	8.5	9.5	18	-	-	-	4 <sup>a</sup>	20 <sup>a</sup>
WB-40	13.5	8.5	50	4	6	13	27	-	-	-	-
WB-50	13.5	8.5	55	3	2	20	30	-	-	-	-
WB-60	13.5	8.5	65	2	3	9.7	20	4 <sup>b</sup>	20.9	5.4 <sup>b</sup>	-
WB-62 <sup>*</sup>	13.5	8.5	69	3	3	20	40-42	-	-	-	-
WB-67 <sup>**</sup>	13.5	8.5	74	3	3	20	45-47	-	-	-	-
WB-96	13.5	8.5	102	2.5	3.3	13.5	20.7	3.3 <sup>d</sup>	21.7	6 <sup>d</sup>	21.7
WB-114	13.5	8.5	118	2	2	22	40	6 <sup>c</sup>	44	6 <sup>c</sup>	-
MH	-	8	30	4	6	20	18	-	-	-	-
P/T	-	8	49	3	10	11	15	5	-	-	-
P/B	-	8	42	3	8	11	21	5	-	-	-
MH/B	-	8	53	4	8	20	6	6	-	-	-

WB<sub>1</sub>, WB<sub>2</sub>, WB<sub>3</sub>, WB<sub>4</sub> are effective wheelbases.

\* = Design vehicle with 48 ft trailer as adopted in 1982 STAA (Surface Transportation Assistance Act).

\*\* = Design vehicle with 53 ft trailer as grand fathered in 1982 STAA (Surface Transportation Assistance Act).

a = Combined dimension 24 ft, split is estimated.

b = Combination dimension 9.4 ft, split is estimated.

c = Combination dimension 8 ft, split is estimated.

d = Combination dimension 9.3 ft, split is estimated.

S = the distance from the rear effective axle to the hitch point.

T = the distance from the hitch point to the lead effective axle of the following unit.

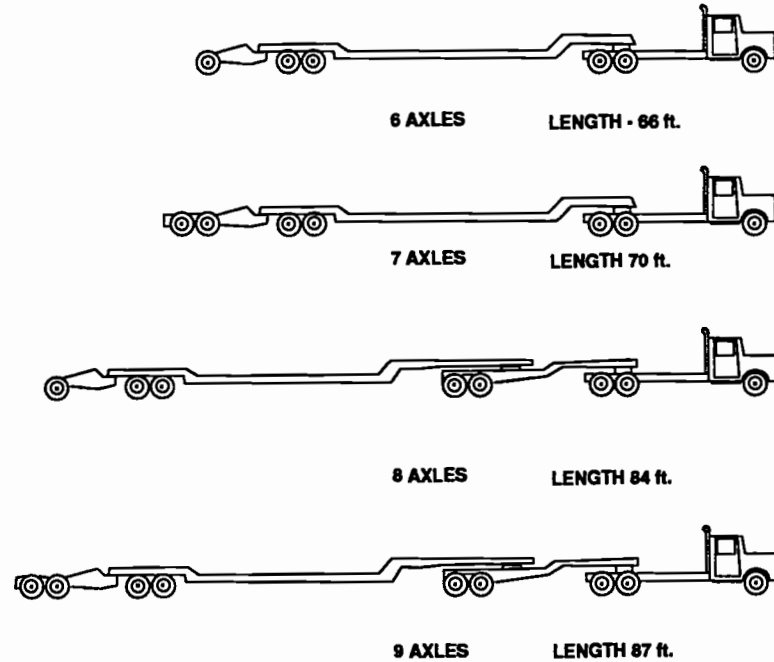
**Table 4. Minimum Turning Radii of Design Vehicles.**

<b>Design Vehicle Type</b>	<b>Design Vehicle Symbol</b>	<b>Minimum Design Turning Radius (ft)</b>	<b>Minimum Inside Turning Radius (ft)</b>
Passenger Car	P	24	13.8
Single Unit Truck	SU	42	27.8
Single Unit Bus	BUS	42	24.4
Articulated Bus	A-BUS	38	14.0
Semitrailer Intermediate	WB-40	40	19.9
Semitrailer Combination Large	WB-50	45	19.2
Semitrailer Full Trailer Combination	WB-60	45	22.2
Interstate Semitrailer	WB-62	45	9.6
Interstate Semitrailer	WB-67	45	10.0*
Triple Semitrailer	WB-96	50	20.7
Turnpike Double Semitrailer	WB-114	60	17.0
Motor Home	MH	40	26.0
Passenger Car with Travel Trailer	P/T	24	2.0
Passenger Car with Boat and Trailer	P/B	24	6.5
Motor Home and Boat Trailer	MH/B	50	35.0

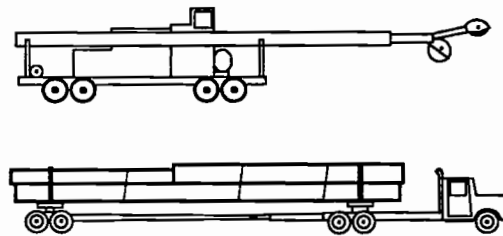
\*Note: The value given by the AASHTO Green Book (1) of 0.0 ft. minimum design turning radius for a WB-67 vehicle is in error and should be approximately 10.0 ft.

Care must be used in applying the minimum turning radii given in Table 4. The minimum turning radius for a design vehicle must consider driver error and the steering wheel not locked in the maximum steering cramp angle position.

Certain vehicles not addressed in the AASHTO Green Book (1) must be considered in the design of resource development roads. These are over-length and over-width tractor trailer trains hauling heavy equipment with off-highway or highway legal overload limits as shown in Figure 2., and special equipment, such as large self-propelled logging equipment and log hauling trucks are shown in Figure 3.



**Figure 2. Tractor-Trailer-Train Combinations.**



**Figure 3. Logging Equipment.**

Minimum turning radius and tracking of vehicles can be accurately determined using vehicle tracking simulation. A drafting vehicle simulator was developed by Kramer (8) and (9). A computer program has been written to determine vehicle tracking, Erkert (10).

### 2.2.1.3 Driver Performance

An appreciation and understanding of driver performance is essential to proper road design, operation, and safety. Design suitability rests as much on the ability of the highway to be used safely and efficiently as on any other criterion, AASHTO Green Book (1). The publication *Positive Guidance in Traffic Control* (11), contains information on the attributes of drivers, the tasks of driving, and information processed by the driver.

#### 2.2.1.4 Design Traffic Volumes

During transportation planning, the decision must be made whether to plan a two-lane or one-lane, two-directional road. The process for this decision is not well documented and contradictions exist between published data, Nielson (12). It is suggested that single-lane, two-directional roads be constructed with average daily traffic (ADT) less than 100 (1, 2). The *Highway Capacity Manual* (13) addresses only two-lane roads with an ADT greater than 400. It is suggested that two-lane roads be constructed with ADT greater than 250. Between 100-250 ADT considerations other than traffic volume must be analyzed in determining the number of lanes required (12).

#### 2.2.1.5 Design Speed

Design speed is the speed determined for design and correlation of the physical features of a road or road segment that influences vehicle operation. It is the maximum safe speed that a vehicle can maintain over a specified segment of road when conditions are so favorable that the design features of the road, rather than operational limitations of the vehicle, govern (1). The design speed is the safe vehicle speed for design only. After determining a road segment design speed, the design elements and standards are based on the design speed to obtain a balanced design.

Terrain and other physical controls may dictate a change in design speed for certain road segments. These changes are applied to road segments between major changes in topography, horizontal and vertical curves, intersections, bridge approaches, etc. A balance must be maintained between driver safety, design speed, vehicle operating costs, and construction costs.

Design speed is also a function of the desired level of service (1,2). In both publications design speeds of 10 to 40 mph are addressed for two-lane and one-lane, two-directional roads. Minimum design speed for resource development and local service roads are in Table 5 (1). Design speed is also addressed in the application of design elements and standards (2).

**Table 5. Design Speed for Low Volume Roads.**

Type of Terrain	One-Lane 100 VPD Maximum (mph)	Two-Lane (mph)
Level	30	40
Rolling	20	30
Mountainous	10	20

## 2.2.2 Road Design Criteria

The Green Book (1) establishes many road design parameters based on a level of service concept for arterial, collector, and local roads, but not for special purpose recreation and resource development roads. The concept of traffic service levels (TSL's) is discussed and their application related to the design of special purpose roads (2).

### 2.2.2.1 Level of Service

The level of service (LOS) concept as applied in the AASHTO Green Book (1) and the *Highway Capacity Manual* (3) do not establish levels of service for low volume one-lane, two-directional roads, or two-lane roads with average an ADT less than 400.

The concept of traffic service levels (TSL's) to establish a level of service structure for low volume roads is in Table 6 (2). This concept is analogous to the levels of service (1, 3).

Design elements and standards are determined based on four traffic service levels, A-D. Traffic service levels describe traffic and operating conditions for a planned road, and are determined during the transportation planning phase. Traffic service level A provides the highest road standard and level D the lowest. Each TSL is defined by several factors, such as class of vehicle, speed, travel time, traffic interruptions, freedom to maneuver, safety, driver comfort, convenience, and operating costs. These factors, in turn, influence the selection of design elements, such as number of lanes, curve widening, horizontal and vertical alignment, turnouts, and road surface type (2).

Table 6. Traffic Service Level Descriptions.

Traffic Characteristics	Traffic Service Levels			
	A	B	C	D
<b>Flow</b>	Free flowing with adequate parking facilities.	Congested during heavy traffic such as during peak logging or recreation activities.	Interrupted by limited passing facilities, or slowed by the road conditions.	Flow is slow or may be blocked by an activity. Two way travel is difficult and may require backing to pass.
<b>Volumes</b>	Uncontrolled; will accommodate the expected traffic volumes.	Occasionally controlled during heavy use periods.	Erratic; frequently controlled as the capacity is reached.	Intermittent and usually controlled. Volume is limited to that associated with the single purpose.
<b>Vehicle Types</b>	Mixed; Includes the critical vehicle and all vehicles normally found on public roads.	Mixed; Includes the critical vehicle and all vehicles normally found on public roads.	Controlled mix; accommodates all vehicle types including the critical vehicle. Some use may be controlled to vehicle types.	Single use; not designed for mixed traffic. Some vehicles may not be able to negotiate. Concurrent use traffic is restricted.
<b>Critical Vehicle</b>	Clearances are adequate to allow free travel. Overload permits are required.	Traffic controls needed where clearances are marginal. Overload permits are required.	Special provisions may be needed. Some vehicles will have difficulty negotiating some segments.	Some vehicles may not be able to negotiate. Vehicle loads may have to be off-loaded and walked into work areas.
<b>Safety</b>	Safety features are a part of the design.	High priority in design. Some protection is accomplished by traffic management.	Most protection is provided by management.	The need for protection is minimized by low speeds and strict traffic controls.

Table 6. Traffic Service Level Descriptions (continued).

Traffic Characteristics	Traffic Service Levels			
	A	B	C	D
<b>Traffic Management</b>	Normally limited to regulatory, warning, and guide signs and permits.	Employed to reduce traffic volume and conflicts.	Traffic controls are frequently needed during periods of high use by the dominant resource activity.	Used to discourage or prohibit traffic other than that associated with the single purpose.
<b>Alignment</b>	Design speed is the predominant factor within feasible topographic limitations.	Influenced more strongly by topography than by speed and efficiency.	Generally dictated by topographic features and environmental factors. Design speeds are generally low.	Dictated by topography, environmental factors, and the design and critical vehicle limitations. Speed is not important.
<b>User Costs</b>	Minimize; transportation efficiency is important.	Generally higher than "A" because of slower speeds and increased delays.	Not important; efficiency of travel may be traded for lower construction costs.	Not considered.
<b>Road Surface</b>	Stable and smooth with little or no dust, considering the normal season of use.	Stable for the predominant traffic for the normal use season. Periodic dust control when required. Smoothness is commensurate with design speed.	May not be stable under all traffic or weather conditions during the normal use season. Surface rutting, roughness, and dust may be present, but controlled for environmental or investment protection.	Rough and irregular. Travel with low clearance vehicles is difficult. Stable during dry conditions. Rutting and dusting controlled only for soil and water protection.



### 2.2.3 Example Design Elements and Standards for a Road Design

An example of the application of the design elements and standards is provided to give a perspective of their use. Road management objectives and design elements are determined in the example, Cactus Mountain project resource planning area for road No. 1200, in Section 4. More detailed design standards are developed during design, using this information and data. Details of the application of these design elements and standards are further explained in Section 4 and are in Appendix A.

For this example Road No. 1200 must be designed in accordance with the National Transportation Safety Act due to mixed traffic operating on the facility. The road will facilitate recreation and resource development traffic. The maximum estimated ADT is 100. The TSL is determined to be B. The road will be a one-lane, two-directional facility with a design speed of 20 mph.

#### Design elements:

- Design vehicle - automobile.
- Critical vehicle - tractor with a 36 ft trailer.
- Design speed - 20 mph.
- No. Lanes - one, two-directional.
- Drainage ditches

#### Road geometric standards:

- Turn outs - intervisible, 10 ft wide, 75 ft length, and 50 ft tapers at each end.
- Maximum turnout spacing - 1,000 ft.
- Minimum horizontal curve radius - 100 ft.
- Maximum grade -  $\pm 10\%$ .
- Minimum vertical curve - 200 ft.

#### Cross-section standards:

- Surface traveled-way width - 14.0 ft.
- Surface templet - crowned 5%.
- Shoulder - 2.0 ft each side of road.
- Ditch - fore slope 3:1, depth 1.0 ft, culvert catch basins 3 ft wide, 3 ft deep.
- Cut slope - 1:1 common material, 3/4:1 rippable rock.
- Fill slope - 1.5:1 common material, 1.33:1 rippable rock.

**Road surfacing standards:**

Surface course - 3/4 in minus dense graded aggregate, 6.0 in depth, 2:1 slope.

Base course - 1 in minus open graded aggregate 8.0 in depth, 2:1 slope.

**Other required standards:**

Culvert spacing - maximum 300 ft.

Parking facility - design for 25 automobiles.

### 3 ROAD DESIGN

Design data from the AASHTO Green Book (1), the U.S.F.S Preconstruction Handbook (2) and other supplemental references are presented and evaluated. Design aids to assist a road designer in evaluating specific design elements and standards for low volume roads are presented.

The AASHTO Green Book (1) addresses the design of low volume special purpose roads. However, the design information presented is not sufficient to adequately consider many specific design considerations, that must be addressed in the design of low volume recreation and resource development roads, required to meet specific resource management requirements.

The U.S.D.A. Forest Service has developed road design criteria, elements, and standards for the design of low volume special purpose roads that are not addressed in the AASHTO Green Book (1); these have been implemented nationally on all national forests (2).

#### 3.1 Design Elements and Standards

The determination of appropriate road design elements and standards is key to a successful road design that meets required resource management objectives. A road designer must have a thorough understanding of their application for each road design situation.

#### 3.2 Sight Distance

The ability of a vehicle operator to see ahead is of the utmost importance in the consideration of safe and efficient vehicle operation, AASHTO Green Book (1). Thus, stopping and passing sight distance are key elements in a safe road design. These elements influence horizontal and vertical curve design, passing lanes, and the design of adequate passing tangent distances.

##### 3.2.1 Stopping Sight Distance

Sight distance is the length of roadway ahead visible to a vehicle operator. The minimum sight distance on a roadway should be sufficiently long to enable a vehicle traveling at or near the design speed to stop before reaching a stationary object in its path. Although greater length is desirable, sight distance at every point along the roadway should be at least that required for a below-average operator or vehicle to stop within this distance, AASHTO Green Book (1).

Safe stopping sight distance (*S.S.D.*) for two-lane roads is computed by the following equation (1). Safe stopping distance on one-lane, two-directional roads is approximately double the *S.S.D.* computed for a two-lane road to provide for safe stopping of vehicles traveling in opposite directions.

A perception reaction time (*t*) of 2.5 seconds for all road driving conditions is required for design (1). Two reaction perception times (*t*) are applied, 2.5 seconds for traffic service levels A and B and 2.0 seconds for traffic service levels C and D (2).

The following rationale is applied to justify the application of two different perception reaction times (2). A *t* of 2.5 seconds is applied to roads with traffic service levels A and B, these two TSL's involve mixed traffic with the potential of relatively complex driving situations. A *t* of 2.0 seconds is applied for TSL's C and D, as driving situations are considered less complex with lower design speeds and fewer distractions.

$$S.S.D. = 1.47Vt + \frac{V^2}{30(f \pm G)}$$

Where:

*V* = vehicle speed (mph).

*t* = vehicle driver perception reaction time (sec.)

*f* = coefficient of vehicle stopping friction.

*G* = road grade vehicle is stopping on (decimal percent).

In the consideration of safe stopping distance on two-lane roads, a vehicle operators eye level height above the ground has been determined to be 3.5 ft for modern automobiles. The vehicle operator with a 3.5 ft eye level height must be able to see an object 0.5 ft high within the safe stopping distance. For large trucks a vehicle operator's eye height is 8.0 ft. For passing sight distance the height of object is 4.5 ft, the average height of a modern automobile (1).

On one-lane, two-directional roads, adequate sight distance must be available for one vehicle to reach a turnout and provide stopping distance for a vehicle traveling in the opposite directions to stop before colliding. Criteria for measuring stopping sight distance for this situation assumes a vehicle operator's eye height of 3.5 ft and the height of the opposing vehicle is 4.25 ft. Stopping sight distance on one-lane, two-directional roads is approximately twice the stopping sight distance for a two-lane road (1).

Vehicle tire to road tractive coefficients are an important factor in determining vehicle safe stopping distance. Five vehicle braking tractive coefficients ( $f$ ) for different road surface types and conditions are in Table 7, and safe stopping sight distances for the given tractive coefficients are in Table 8 (2).

**Table 7. Braking Tractive Coefficients.**

Road Surface Conditions	Tractive Coefficient ( $f$ )	Design Speed (mph)
Ice	0.1	10-20
Loose snow	0.2	10-20
Snow, lightly sanded Clay, wet	0.3	10-20
Wet earth Loose gravel Wet asphalt Wet packed gravel	0.4	10- 40
Dirt earth Dry packed gravel Crushed rock Dry asphalt	0.5	10-50

The values for safe stopping distance in Table 8 are computed for TSL's A through D on two-lane roads. Perception reaction time ( $t$ ) for TSL's A and B is 2.5 seconds and 2.0 seconds for traffic service levels C and D. Grade ( $G$ ) in the stopping sight distance equation is 0.0 percent for the values of tractive coefficients ( $f$ ) and design speeds in Table 8 (2).

Minimum stopping sight distance criteria for design speeds 10 to 40 mph for two-lane and one-lane, two-directional traffic are in Table 9 (1). A zero percent grade is applied.

**Table 8. Stopping Sight Distance on Two-Lane Roads.**

Road Surface Conditions	Tractive Coefficient ( $f$ )	Design Speed (mph)	T.S.L. (A & B) S.S.D. (ft)	T.S.L. (C & D) S.S.D. (ft)
Ice	0.1	10	70	62
		15	130	118
		20	207	281
Loose snow	0.2	10	53	46
		15	92	81
		20	140	125
Snow, lightly sanded wet clay	0.3	10	48	40
		15	77	69
		20	118	103
Wet earth Loose gravel Wet asphalt Wet packed gravel	0.4	10	45	38
		15	74	63
		20	107	92
		25	144	125
		30	185	162
		35	230	202
		40	280	250
45	334	299		
Dirt earth Dry packed gravel Crushed rock Dry asphalt	0.5	10	43	36
		15	70	59
		20	100	85
		25	133	115
		30	170	148
		35	210	184
		40	263	223
		45	312	266
50	365	312		

**Table 9. Minimum Stopping Sight Distance.**

Design Speed (mph)	10	20	30	40
Two-lane roads and one-lane roads (one-direction)	50	125	200	275-325
One-lane roads (two-direction)	100	250	400	-

### 3.2.2 Passing Sight Distance

Passing sight distance is applied only on two-lane roads. On one-lane, two-directional roads, turnouts are used for vehicles passing. Minimum passing sight distances on two-lane road for design speeds of 20, 30, and 40 mph are in Table 10 (1). The effects of vehicle passing distance on positive and negative grades are not

addressed in the U.S.F.S. Preconstruction Handbook (2). In the AASHTO Green Book (1) the only reference to passing sight distance is that it must be increased on positive grades, but provides no criteria.

**Table 10. Minimum Passing Sight Distance on Two-lane Roads.**

Design Speed (mph)	Minimum Passing Sight Distance (ft)
20	800
30	1,100
40	1,500

The equation for safe passing distance (*S.P.D.*) is:

$$S.P.D. = d_1 + d_2 + d_3 + d_4$$

$d_1$  = the distance traveled during perception reaction time during the initial acceleration to the point of encroachment in the left lane (Figure 4).

$$d_1 = 1.47t_1 \left( V - M + \frac{at_1}{2} \right)$$

Where:

$t_1$  = time of initial maneuver (sec).

$a$  = average acceleration (mph/sec).

$V$  = average speed of passing vehicle (mph).

$M$  = difference in speed (mph).

$d_2$  = distance traveled by passing vehicle when occupying left lane (ft).

$$d_2 = 1.47Vt_2$$

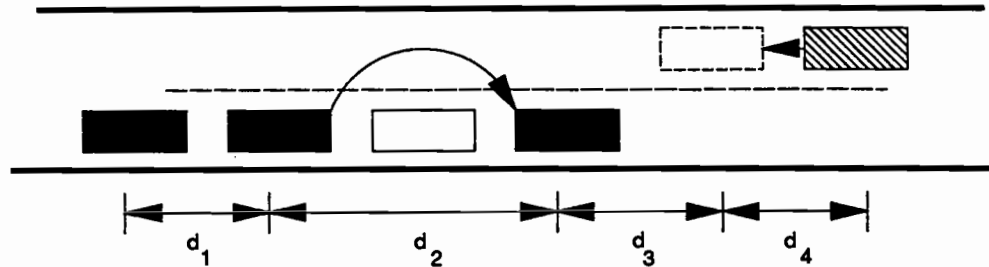
Where:

$t_2$  = the time passing vehicle is in the left lane (sec).

$V$  = the average speed of passing vehicle (mph).

$d_3$  = the distance between the passing vehicle at end of maneuver, 100 ft from 30-40 mph, and 300 ft from 60-70 mph.

$d_4$  = the distance traveled by an opposing vehicle for  $2/3$  of the time the passing vehicle occupies the left lane,  $2/3d_2$ , the  $1/3d_2$  excluded is the travel time while the passing vehicle is trailing the vehicle being passed, until they are abreast (Figure 4).



**Figure 4. Safe Passing Sight Distance.**

### 3.3 Horizontal and Vertical Alignment Control

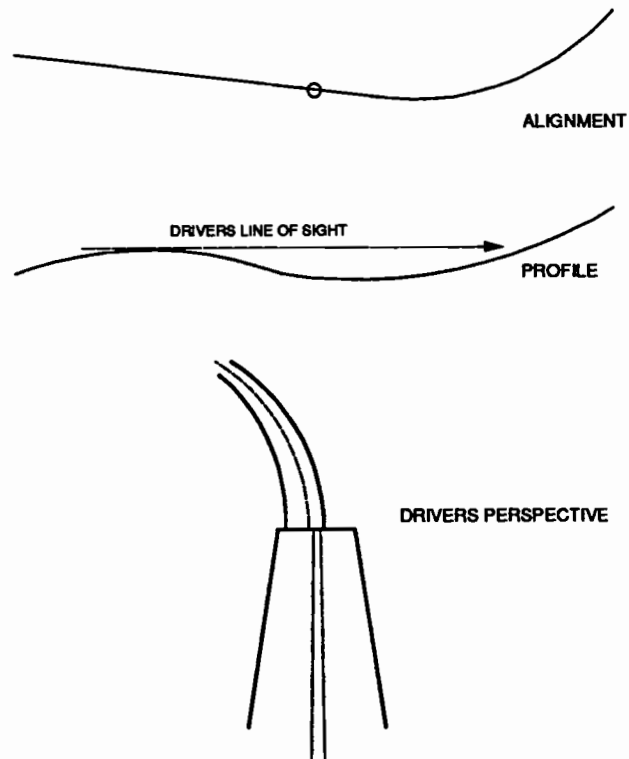
Horizontal and vertical alignment are permanent design elements. Adequate road location must be performed prior to design to eliminate serious alignment problems. This is critical on low volume, resource development roads where maximum grade and minimum radius curves are to be considered in design. It is often difficult and costly to correct deficiencies in alignment and profile once a road is constructed. Alignment and profile errors can cause adverse impacts on vehicle safety, operating costs, and resource development activities.

Horizontal and vertical alignment can not be designed independently as they must complement each other. Some examples of good and bad alignment design practices are illustrated in Figure 5 and Figure 6 (1).

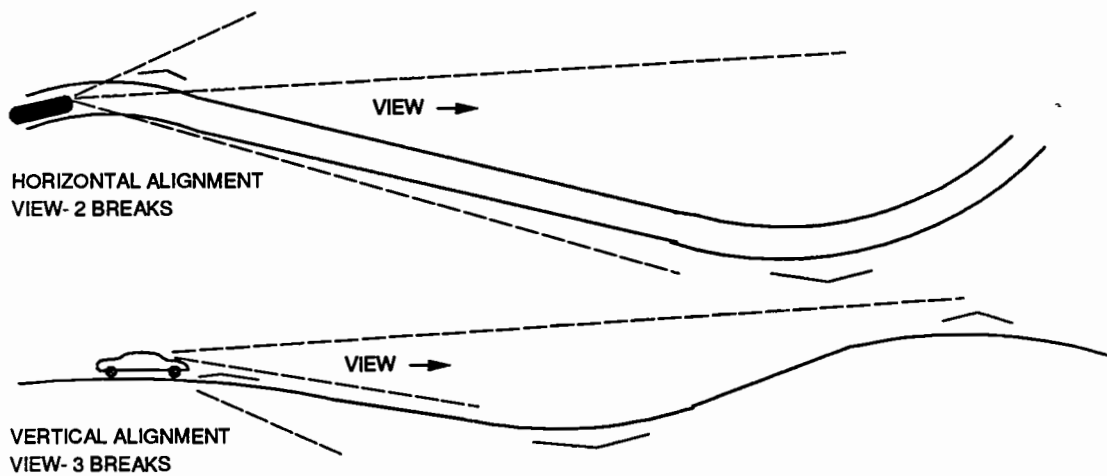
A disjointed effect occurs when a driver approaches the crest of a vertical curve, and viewing over the crest, sees a horizontal curve on the other side of the vertical curve before seeing the road directly beyond the crest of the vertical curve (Figure 5).

A good balance between vertical and horizontal alignment provides a driver with adequate sight distance to be able to view the travel way ahead, where changes in horizontal and vertical alignment occur. This condition is illustrated in Figure 6.





**Figure 5. Disjointed Sight Effect.**



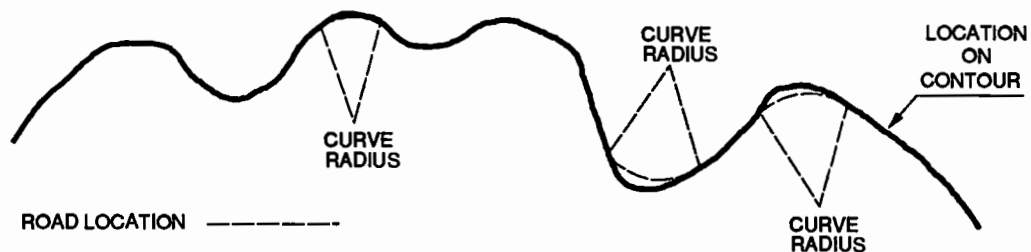
**Figure 6. Horizontal and Vertical Alignment Balance.**

Design speed can have a significant effect on horizontal and vertical road alignment in mountainous terrain. As vehicle speed increases, safe stopping distance increases, often requiring longer vertical and horizontal curves in order to provide adequate stopping sight distance. In hilly and mountainous terrain, design speed has

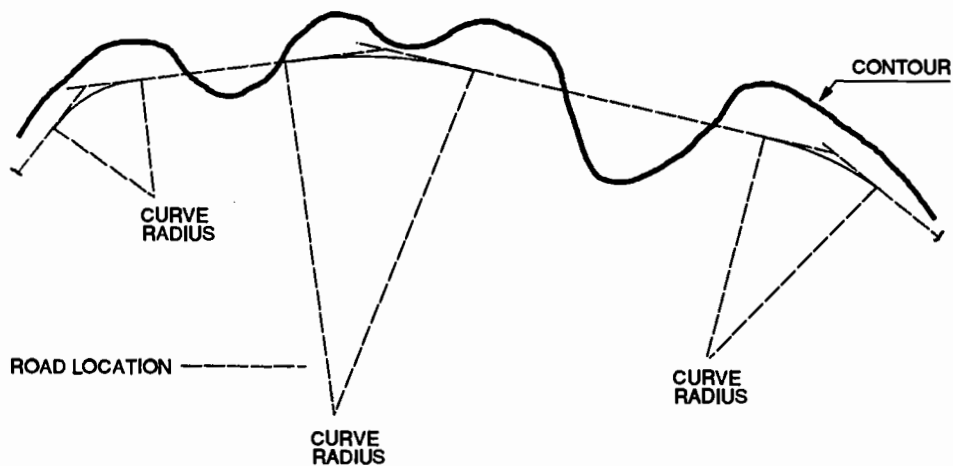
a direct effect on construction and maintenance costs and environmental impacts. Higher design speeds generally result in greater excavation quantities, higher construction and maintenance costs, and greater environmental impacts.

Two types of horizontal alignment can be applied in a design of special purpose roads; non-geometric design (Figure 7) and geometric design (Figure 8). Non-geometric road design is not addressed in (1) or (2), however it is an accepted design practice. In a non-geometric design, horizontal alignment follows landform contours (Figure 7). When a natural contour curve is less than the minimum required road curve, a road curve is designed at that location point (Figure 7).

For design speeds less than 20 mph, non-geometric design can yield less excavation, less cost, and reduced visual and environmental impacts as compared to a standard geometric design with horizontal tangents and designed simple horizontal curves on the same location. Disadvantages of non-geometric alignment are longer road length and lower design speed, as compared to a standard highway geometric design on the same location (Figure 8).



**Figure 7. Non-Geometric Horizontal Alignment.**



**Figure 8. Geometric Horizontal Alignment.**

### 3.3.1 Horizontal Curves

To obtain a balance in a design of horizontal curves, all geometric elements should, as far as economically feasible, be determined to provide safe continuous operation at a speed likely for the general road conditions (1).

#### 3.3.1.1 General Design Considerations

The relationship between design speed, curve radius, vehicle tire side friction, and superelevation must be balanced to attain a safe design and provide for driver comfort. The data are developed in the AASHTO Green Book (1) and is described as follows.

#### 3.3.1.2 Minimum Radius Curve for a Given Design Speed

Minimum curve radius is a significant value in alignment design when vehicle speed is the primary design concern. The minimum curve radius for a given design speed is determined by using the maximum rate of superelevation and acceptable safe side coefficient of friction. The minimum safe radius ( $R_{\min}$ ) can be calculated directly using the following equation.

$$R_{\min} = \frac{V^2}{15(e + f)}$$

Where:

$e$  = rate of superelevation (ft/ft).

$f$  = tire side friction factor.

$V$  = vehicle speed (mph).

#### 3.3.1.3 Transition from a Tangent to a Simple Horizontal Curve

All vehicles follow a transition track, or path, as they enter and leave a simple horizontal curve. Vehicle steering change and the gain or loss of centrifugal force cannot be obtained instantaneously. On many curves, an average driver can effect a suitable transition path within the limits of a normal lane width. However, with the combination of high speed and sharp horizontal curves, a driver may be forced to occupy a portion of an adjoining lane. In this situation, a transition curve, or spiral curve, between a tangents and the beginning and end of a simple curve could be appropriate (1).

### 3.3.1.4 Superelevation

The design speed of a curve is affected by curve radius, vehicle tire side slip traction, and road surface superelevation rate. Superelevation is not a consideration in design speeds less than 20 mph (1, 2). For design speeds greater than 20 mph, the following superelevation equation is applied. The equation is used to determine the required superelevation for a given curve radius ( $R$ ) and tire side slip friction factor ( $f$ ), or to determine a minimum curve radius ( $R$ ) when the superelevation rate ( $e$ ) and design speed ( $V$ ) are known.

$$e + f = \frac{V^2}{15R}$$

Where:

$e$  = superelevation rate ( decimal percent).

$f$  = side slip friction factor.

$V$  = vehicle velocity (mph).

$R$  = curve radius (ft).

For low volume, special purpose roads, the AASHTO Green Book (1) applies a side slip friction factor ( $f$ ) of 0.12 for 10 mph and 0.10 for 30 mph on gravel surfacing. The U.S.F.S Preconstruction Handbook (2) gives the following equation for determining side friction factor ( $f$ ). The tractive coefficient ( $T_f$ ) is the coefficient of friction of a vehicle tires to road surface, and the constant 0.20 is a factor reflecting an average vehicle operators driving comfort level and safety. Values of  $T_f$  for various road surfaces and surface conditions are in Table 11 (2).

$$f = T_f - 0.20$$

**Table 11. Tractive Coefficients for Various Road Surfaces.**

Surface Material	Surface Condition	
	Dry ( $T_f$ )	Wet ( $T_f$ )
Concrete	0.75-0.90	0.55-0.70
Asphalt	0.55-0.70	0.40-0.70
Gravel, packed, oiled	0.50-0.85	0.40-0.80
Gravel, loose	0.40-0.70	0.36-0.65
Rock crushed	0.55-0.75	0.55-0.75
Earth*	0.55-0.65	0.40-0.50
Dry packed snow	0.20-0.55	-
Loose snow	0.10-0.60	-
Snow, lightly sanded	0.29-0.31	-
Snow, lightly sanded with chains	0.34	-
Ice without chains	0.07-0.12	-

\*Note: Reduce  $T_f$  for wet clay surfacing by 50%.

### 3.3.1.5 Superelevation Runoff

Superelevation runoff, or transition, is used to provide safe vehicle transition from a crowned tangent into and through a superelevated horizontal curve. Driver comfort is an element of consideration. Superelevation through curves is also necessary to provide proper road surface drainage. There are two design procedures used to accomplish this. One is to design spiral curves on both ends of a simple curve. The second method is to design tangents and simple curves, introducing part of the superelevation on the tangents and the remaining spiral length on the simple curve. The AASHTO Green Book (1) describes the use of spiral curves in depth.

To obtain the necessary length of spiral, the Euler spiral, also known as the clothoid spiral, is used by some agencies. The length of spiral curve ( $L$ ) can be determined by the Shortt equation (1).

$$L = \frac{3.15V^3}{RC}$$

Where:

$V$  = vehicle speed, (mph).

$R$  = curve radius, (ft).

$C$  = rate of increase of centripetal acceleration, (ft/sec).

The factor ( $C$ ) is an empirical value used to indicate driver comfort and safety. Values ranging from 1 to 3 have been used for highways (1). This formula is modified by some agencies to account for superelevation, which results in a shorter length of superelevation runoff. Agencies that do not use spiral curves empirically designate proportional tangent and simple curve lengths to accomplish the same purpose.

Review of current design practices indicates that the appearance aspect of superelevation runoff governs spiral length. These lengths are usually longer than those derived by empirical methods. A number of agencies have established one or more control runoff lengths within a range of approximately 100 to 600 ft (1). When considering two-lane pavement with plane sections, the difference in longitudinal gradient between the edge of pavement profile, and the centerline profile should not exceed 0.5 percent. The relative slope varies with design speed.

In alignment with spirals, superelevation runoff is effected over the entire length of the spiral curve. Full superelevation is carried through a simple curve, from the spiral to curve (S.C.), to the curve to spiral (C.S.). Methods for design control use the inside edge, centerline, or outside edge of a road as the point of rotation as shown in Figure 9, Kavanagh (14).

In a design of curves without spirals, superelevation transition must also be provided. Some agencies require runoff lengths equal to designated spiral lengths for a given degree of curve. Oregon Department of Transportation requires that all unspiraled curves sharper than  $1^\circ$  will have a length of runoff equal to a normal spiral curve length, *Oregon Department of Transportation Design Manual* (15).

When simple curves are used, the placement of the length of runoff with respect to the point of curve (P.C.) and the point of tangent (P.T.) differs with various highway agencies. Most agencies that do not design spiral curves, design with part of the runoff length on the tangent and the remaining length on the curve. Many state agencies apply approximately two-thirds of the runoff length on the curve tangent approach and one third of the length on the curve. Full superelevation is carried through the middle of the simple curve. Both the AASHTO Green Book (1) and the U.S.F.S Preconstruction Handbook (2) give values for superelevation runoff. Values are in Table 12 and Table 13.

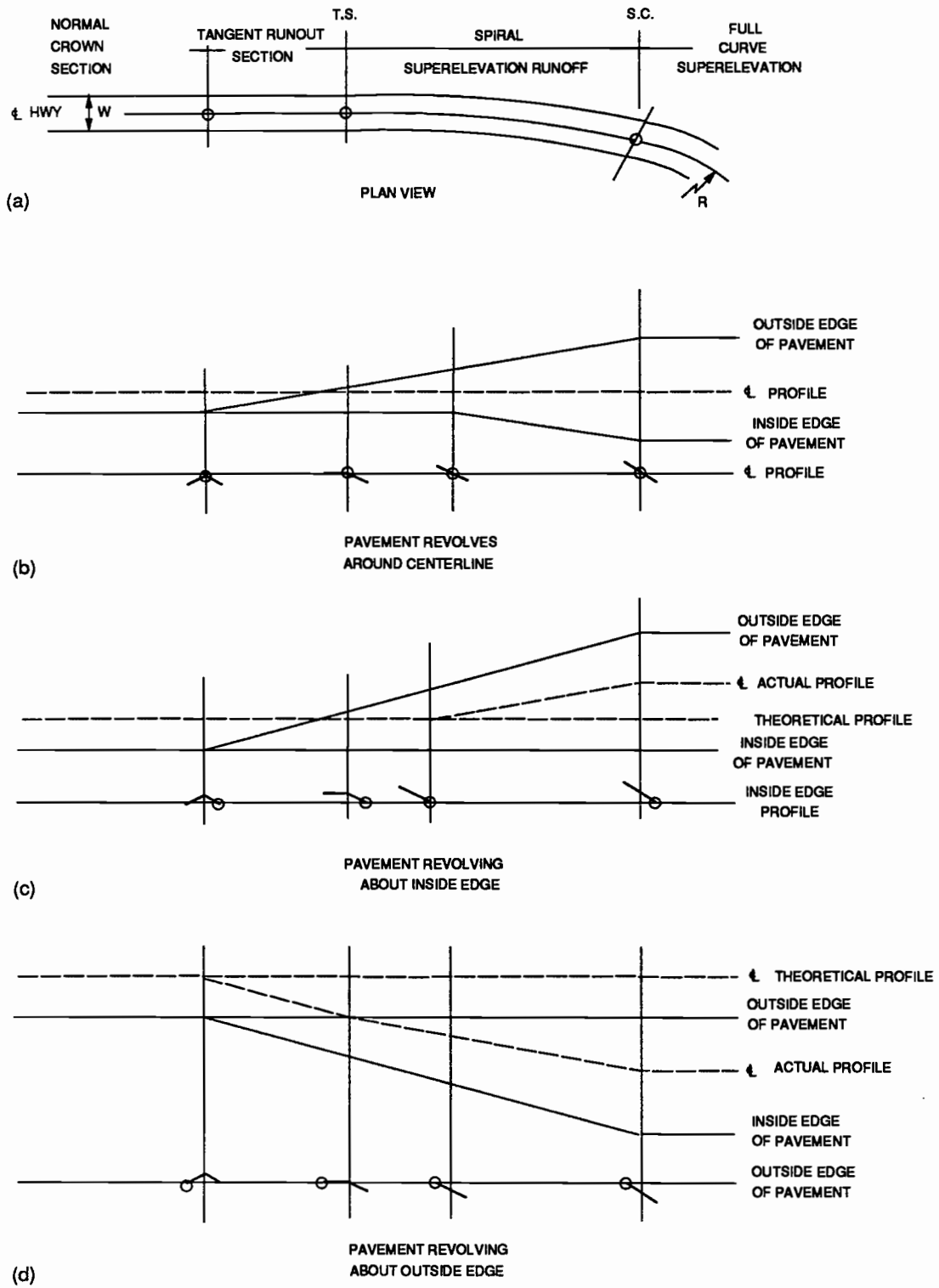


Figure 9. Superelevation for Spiraled Curves.

Table 12. Super Elevation Runoff.

Superelevation rate (%)	Length of Run-off (ft) for Design Speeds (mph)			
	20	30	40	50
<b>12-ft Lanes</b>				
0.02	50	100	125	150
0.04	60	100	125	150
0.06	95	110	125	150
0.08	125	145	170	190
0.10	160	180	210	240
0.12	195	215	250	290
<b>10-ft Lanes</b>				
0.02	50	100	125	150
0.04	50	100	125	150
0.06	80	100	125	150
0.08	105	120	140	160
0.10	130	150	175	200
0.12	160	180	210	240



Table 13. Super Elevation Runoff Distance.

Superelevation Rate (%)	Length of Runoff (ft) for Design Speeds (mph)			
	20	30	40	50
<b>10 ft Lanes</b>				
2	50	100	125	150
4	50	100	125	150
6	50	100	125	150
8	50	120	140	160
10	50	150	175	200
12	50	180	210	240
<b>11 ft Lanes</b>				
2	50	100	125	150
4	50	100	125	150
6	50	100	125	150
8	50	135	155	175
10	50	165	190	220
12	50	200	230	265
<b>12 ft Lanes</b>				
2	50	100	125	150
4	50	100	125	150
6	50	110	125	150
8	50	145	155	175
10	50	180	210	240
12	50	215	250	290
<b>14 ft Lanes</b>				
2	50	100	125	150
4	50	100	125	150
6	50	120	140	160
8	50	160	185	205
10	50	195	230	260
12	50	235	270	315

### 3.3.1.6 Safe Stopping Distance on Horizontal Curves

Safe stopping distances must be provided on horizontal curves for given design speeds. On low volume roads, simple horizontal curves are generally designed, and safe stopping sight distance is provided using the following equation and diagram in Figure 10. The mid-ordinate ( $M$ ) is the minimum lateral clearance distance from the center of the vehicle lane required for a vehicle operator to see the length of curve equal to the required safe stopping sight distance around the curve. A vehicle operator must be able to see the safe stopping sight distance from a eye level height of 3.5 ft to a 0.5 ft high object on the road surface in the lane. A 2 ft height of object at the mid-ordinate point can be used if a cut slope obstructs the line of sight. This condition assumes there is little or not vertical curvature on the horizontal curve (1).

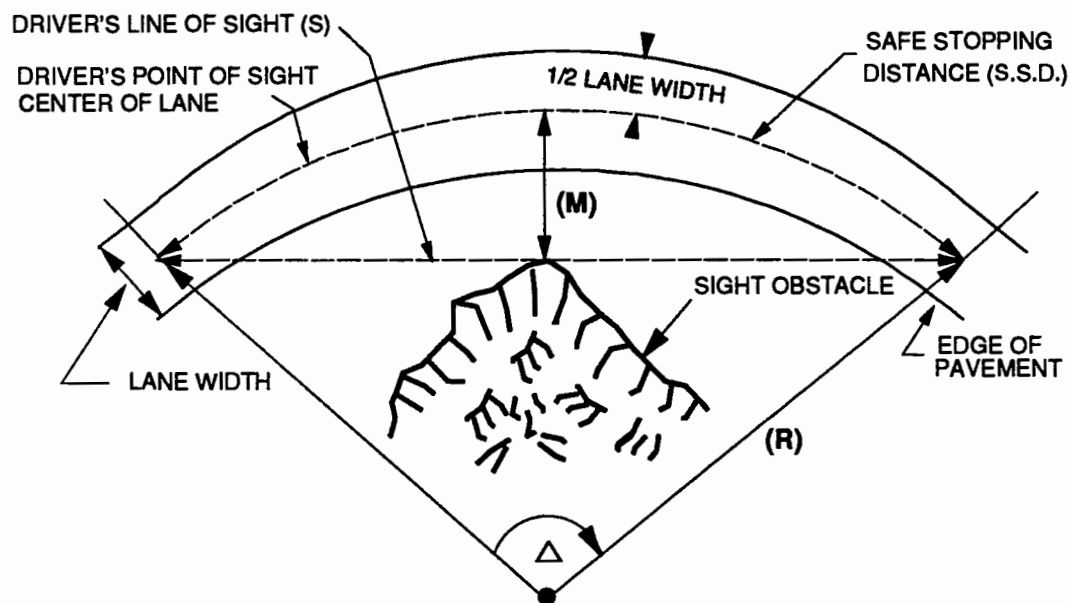


Figure 10. Sight Distance on a Horizontal Curve.

$$M = R - R \cos \left( \frac{(57.2958)(S.S.D.)}{2R} \right)$$

Where:

$R$  = design curve radius minus 1/2 lane width (ft).

$S.S.D.$  = safe stopping distance (ft).

One-lane, two-directional roads require approximately double the safe stopping distance of two-lane roads. On one-lane, two-directional roads turnouts are designed to preclude this design requirement.

Safe stopping distances applied to low volume roads in the AASHTO Green Book (1) are determined only for automobiles. The U.S.F.S Preconstruction Handbook (2) suggests increasing the AASHTO (1) design safe stopping distance for trucks (Table 14). These values assumed paved road surfacing.

**Table 14. Safe Stopping Distance for Trucks.**

Initial truck Speed (mph)	Minimum Sight Distance (ft)
30 or less	1.55( <i>S.S.D.</i> )
30 to 50	1.75( <i>S.S.D.</i> )

Note: *S.S.D.* = safe stopping distance computed for automobiles.

### 3.3.1.7 Curve Widening

Curve widening must be analyzed to provide adequate lane width for the off-tracking of design and critical vehicles, such as log trucks, tractor trailer trains, and logging equipment. On two-lane roads, curve widening is designed for each lane. On one-lane roads, curve widening is usually designed on the inside of curves.

There are several design situations which require vehicle off-tracking analysis. In a design of short radii curves with large deflection angles, vehicle off-tracking must be computed to attain adequate curve widening. When traversing compound reverse curves with different short radii and large deflection angles, a vehicle has a different tracking path in each direction through the curves. Off-tracking analysis must also be performed on bridge locations with short approach tangents, and short radius horizontal curves are located behind or ahead of one-lane bridge approach tangents to insure that a design vehicle does not off-track off the bridge deck.

Off-tracking is a function of a vehicle's geometry and a curve's radius and deflection angle ( $\Delta$ ). The following vehicle dimensions and operating characteristics must be known to determine adequate off-tracking of a vehicle's wheels and overhanging equipment as it traverses horizontal curves; wheelbases, out-to-out wheel widths, steering cramp angle, and vehicle overhang. Current vehicle tracking data assume a vehicle is traveling at a low speed, less than 10 mph. Grade and road surface superelevation are not considered.

The AASHTO Green Book (1) does not adequately address vehicle tracking on low volume roads. The suggested method of computing off-tracking (*O.T.*) is to apply

the modified Voshell equation, where off-tracking and curve radius ( $R$ ) are in feet. This equation can yield significant error in vehicle off-tracking design on short radius curves, because vehicle and curve geometry are not considered.

$$O.T. = \frac{400}{R}$$

The following example illustrates the potential error in applying the modified Voshell off-tracking equation. A lowboy tractor trailer with 8.0 ft out-to-out wheel width, tractor wheelbase 18 ft, trailer length 36 ft from center of rear axles to 5th wheel hitch, a 60 ft curve radius ( $R$ ), and 140 degree central angle ( $\Delta$ ).

Applying the modified Voshell equation vehicle off-tracking is 7.1 ft. Actual off-tracking is 14.5 ft by analysis, using a drafting vehicle simulation (8, 9) and the off-tracking computer program (10). The modified Voshell equation yields vehicle off-tracking values 51 percent less than actual vehicle off-tracking.

Equations have been developed to compute off-tracking of tractor trailer trains and a stinger type log truck. Off-tracking graphs have been developed applying these equations for a tractor trailer units and a log truck of specific dimensions (2). The off-tracking equation is:

$$O.T. = R - \sqrt{(R^2 - L^2) \left( 1 - e^{\left( \frac{-0.15\Delta R}{L} + 0.216 \right)} \right)}$$

Where:

$R$  = central radius (ft).

$e$  = base of natural logarithms.

$\Delta$  = central angle (degrees).

$L$  = effective vehicle length (ft).

The effective vehicle length ( $L$ ) for a lowboy tractor trailer combination is:

$$L = \sqrt{L_1^2 + L_2^2 + L_3^2}$$

Where:

$L_1$  = wheelbase of the tractor (ft).

$L_2$  = distance from fifth wheel to center of rear duals of the first trailer (ft).

$L_3$  = distance from fifth wheel to center of rear duals of second trailer.

The effective vehicle length ( $L$ ) for a stinger type log truck is:

$$L = \sqrt{L_1^2 + L_2^2 + L_3^2}$$

Where:

$L_1$  = wheelbase of the tractor (ft).

$L_2$  = length of the stinger measured from middle of tractor rear duals to end of stinger (ft).

$L_3$  = bunk to bunk distance minus length of stinger of rear duals of second trailer.

An advantage of using the off-tracking equations is that off-tracking computations can be made by hand or programmed on a calculator. Limitations of the equations are; vehicle steering cramp angle, vehicle overhang, and vehicle off-tracking that occurs before a point of curve (P.C.) and after a point of tangent (P.T.) are not considered in the computations. Off-tracking results using the equations correlate with values calculated using the vehicle drafting simulator, Kramer (8, 9) and the off-tracking computer program, Erkert (10). The U.S.F.S Preconstruction Handbook (2) provides curve widening requirements for each of the four TSL's, A through D (Table 15).

**Table 15. Curve Widening for Traffic Service Levels.**

Traffic Service Level	Curve Widening Requirements
A	Design curve widening to accommodate a design vehicle. Curve widening for a critical vehicle should be provided by other elements, if feasible, such as turnouts and shoulders. If not feasible design curve widening to accommodate the critical vehicle. A critical vehicle should be accommodated in its normal travel configuration.
B	Same as traffic service level A.
C	Same as traffic service level A, except a critical vehicle configuration may have to be altered to traverse the road.
D	Design curve widening only for a design vehicle. Loads carried by a critical vehicle should be off-loaded and walked to a project or transferred to a vehicle capable of traversing a road. Temporary widening to permit the passage of critical vehicles may be accomplished at narrow sections. These constraints should be reflected in design criteria and road management objectives.

The off-tracking computer program (10), calculates off-tracking of any single unit vehicle, tractor trailer combinations, and vehicle overhang on road section through simple and compound curves. An advantage of using this program is that analysis can be performed rapidly on long complex sections of road. Limitations of the program are; vehicle steering cramp angle is not considered, there is no capability to simulate a vehicle backing up and turning to negotiating a curve where extra travel way widening is provided, such as a turnout on a one-lane road curve, and vehicle overhang data output must be plotted.

The Drafting Vehicle Simulator, is a mechanical scale model operated by hand (8, 9). Horizontal road alignment and road surface dimensions are drafted on a scale of 1 inch to 10 feet. The simulator is adjusted using the same scale. Single unit and tractor trailer train combinations can be modeled. Advantages of this model are; steering cramp angle can be set and backing maneuvers can be accomplished and analyzed. Backing maneuvers are simulated to analyze off-tracking on curves with extra travel way widening such as a turnout.

Off-tracking of equipment overhang traversing a resource development road must be computed to determine cut bank design on the inside of curves and/or curve widening to allow for equipment passage. A large piece of self-propelled logging equipment, with a forward down-rigged tower, must be able to negotiate a given curve. The tower clearance is analyzed to determine the horizontal and vertical off-sets which are illustrated in Figure 11 and Figure 12.

**Vehicle dimensions nomenclature:**

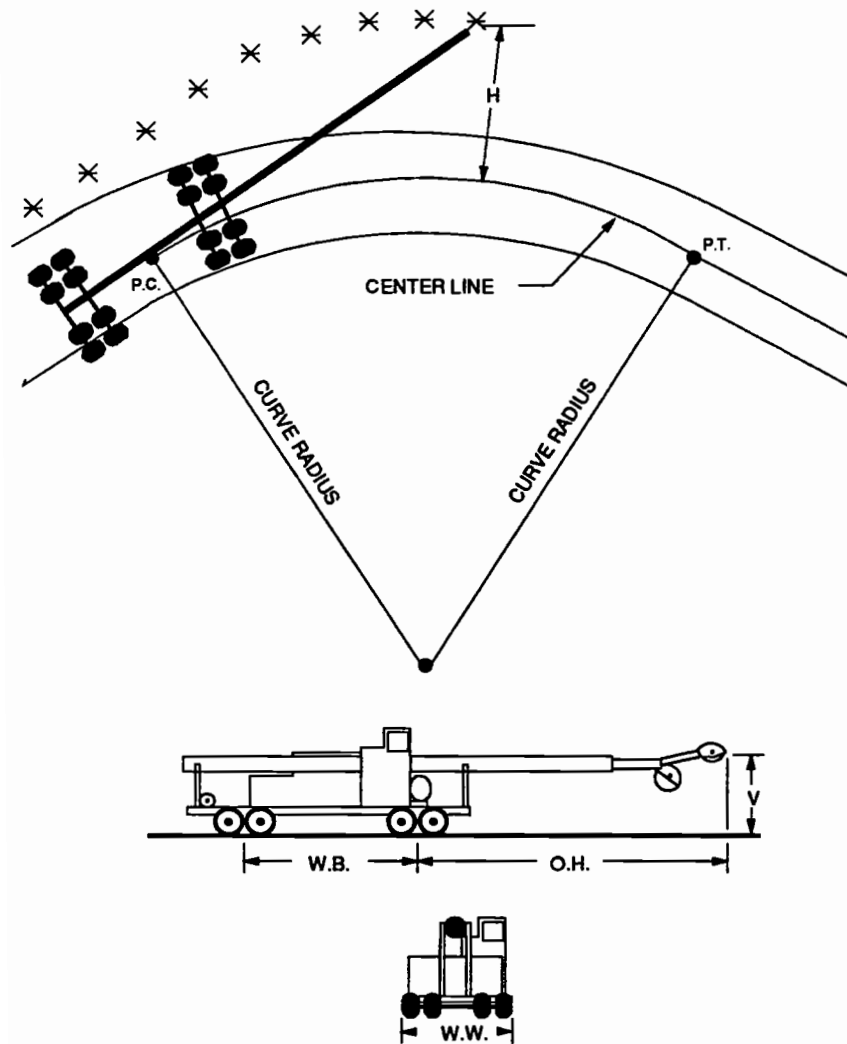
**W.B. = wheelbase.**

**O.H. = tower overhang distance from center of front axles.**

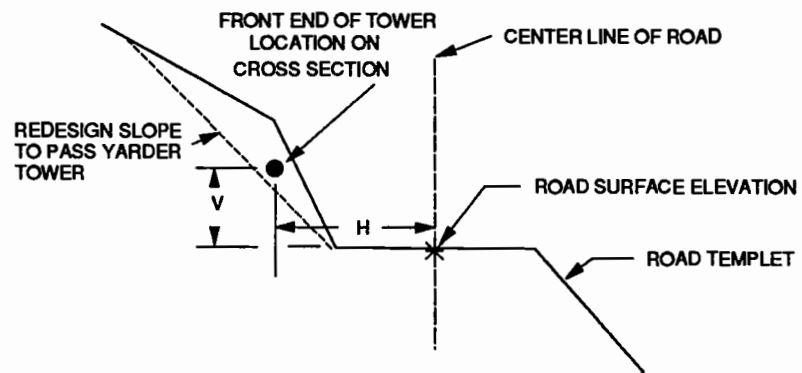
**W.W. = out-to-out wheel width.**

**V = vertical distance from ground to front end of the tower.**

The maximum off-tracking of the yarder tower is plotted. The horizontal tower off-tracking distance (H) is measured on a line from the center of the vehicle to the end of the tower (Figure 11). The road cross section at the point of maximum tower off-tracking is plotted, and the elevation (V) measured (Figure 13). The location of the end of the tower is plotted on the cross section. In Figure 13, the end of the tower is located below the cross section cut ground line. The cut slope must be flattened and/or the road templet widened to the right to provide passage clearance for the tower.



**Figure 11. Overhang Clearance Plotting.**



**Figure 12. Position of Log Yarder Tower on Road Section.**



### 3.3.1.8 Curve Widening Tapers

Curve widening tapers for low volume roads are not specifically addressed in the AASHTO Green Book (1). However, it is stated that tapers should be between 100 and 200 feet. The U.S.F.S Preconstruction Handbook (2) states that curve widening tapers should be a straight line distance before a curve point of curve (P.C.) and ahead from the curve point of tangent (P.T.). Given values are in Table 16.

**Table 16. Curve Taper Values.**

Curve Radius (ft)	Taper Length (ft)
< 70	60
70 - 85	50
86 - 100	40
> 100	30

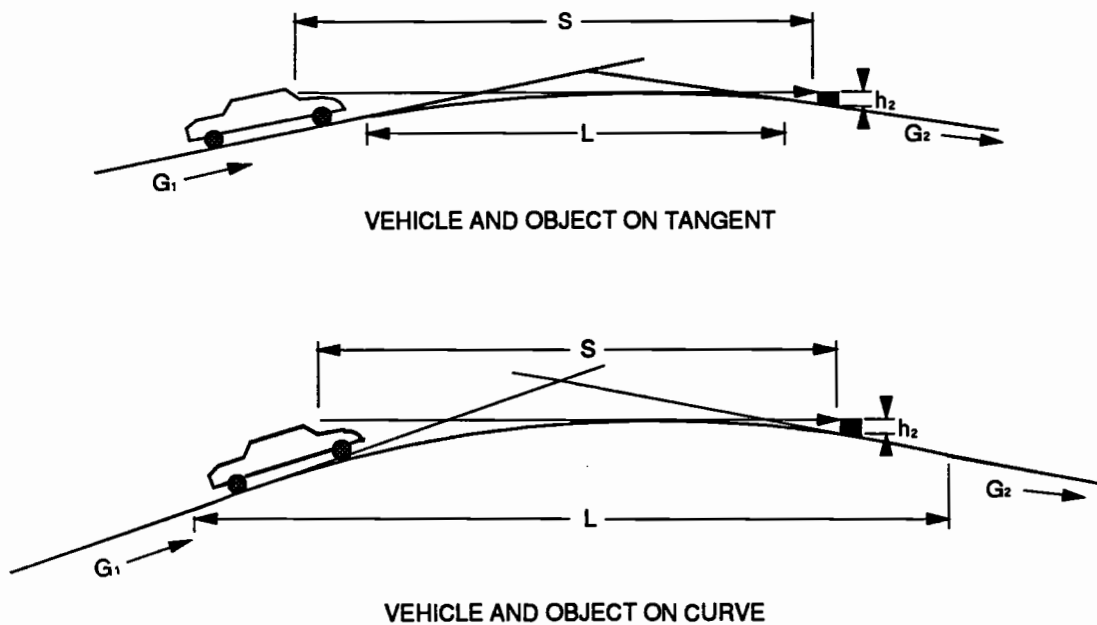
### 3.3.2 Vertical Curves

Vertical curves are used for grade transition, either crest or sag curves are used for this purpose. The AASHTO Green Book (1) states that a minimum length of vertical curve can vary from 100 to 300 ft or three times a design speed, depending on local jurisdiction. The U.S.F.S. Preconstruction Handbook (2) suggests a minimum 50 ft vertical curve length. Care must be taken when applying this minimum curve length for tractor trailer combinations, particularly for a critical vehicle, to insure that the bottom front end of a trailer does not hit the ground in a sag vertical curve or broach on a crest vertical curve. Stinger type log trucks must be considered to insure that the stinger and reach will not hit the road surface on sag vertical curves or that a reach and stinger will not broach and hit the log load on a crest vertical curve.

No specific procedures are given by either the AASHTO Green Book (1) or the U.S.F.S. Preconstruction Handbook (2) regarding values of grade to be applied in determining a safe stopping sight distance on vertical curves. Mannering (7) states that jurisdictions apply a grade, varying between the most conservative case, which is a negative grade on a vertical curve, to a grade of zero percent. Some jurisdictions use an average grade, averaging the grades of a vertical curve and using this value in the safe stopping distance equation.

### 3.3.2.1 Crest Vertical Curves

For crest vertical design (Figure 13), safe stopping sight distance ( $S$ ) is based on a 3.5 ft height of drivers eye ( $h_1$ ) and height of object ( $h_2$ ) of 0.5 ft above a road surface.



**Figure 13. Crest Vertical Curve.**

An assumption must be made as to whether the length of curve ( $L$ ) is greater or less than the safe stopping distance ( $S$ ). For  $h_1=3.5$  ft and  $h_2=0.5$  ft, the following equations are applied. In the following equations,  $A$  is the algebraic difference between ( $G_1$ ) and ( $G_2$ ).

Where:  $S > L$

$$L = 2S - \frac{200(\sqrt{h_1} + \sqrt{h_2})^2}{A}$$

$$L = 2S - \frac{1329}{A}$$

Where:  $S < L$

$$L = \frac{AS^2}{100(\sqrt{2h_1} + \sqrt{2h_2})^2}$$

$$L = A \frac{S^2}{1329}$$

With:

$L$  = length of vertical curve (ft).

$S$  = safe stopping distance (ft).

$A$  = algebraic difference  $|G_2 - G_1|$  (percent).

### 3.3.2.1.1 Vertical Curve Road Surface Sight Distance

Road surface sight distance or, "pavement sight distance", is an important design concept for the design of crest vertical curves on low volume roads. Sight distance is important for safety where alignment is arduous, the road templet narrow, and side slopes steep (Figure 14). This is of particular importance in the design of crest vertical curves with mixed heavy vehicle traffic. A driver must be able to decide if there is sufficient vehicle maneuvering space to pass an oncoming vehicle or be required to stop. To safely accommodate this situation, a minimum length of crest vertical curve can be determined by the following equations where a driver's eye level height is 3.5 ft and height of object 0.0 ft above a road surface.

Where:  $S > L$

$$L = 2S - \frac{200(\sqrt{h})^2}{A}$$

$$L = 2S - \frac{700}{A}$$

Where:  $S < L$

$$L = \frac{AS^2}{100(\sqrt{2h})^2}$$

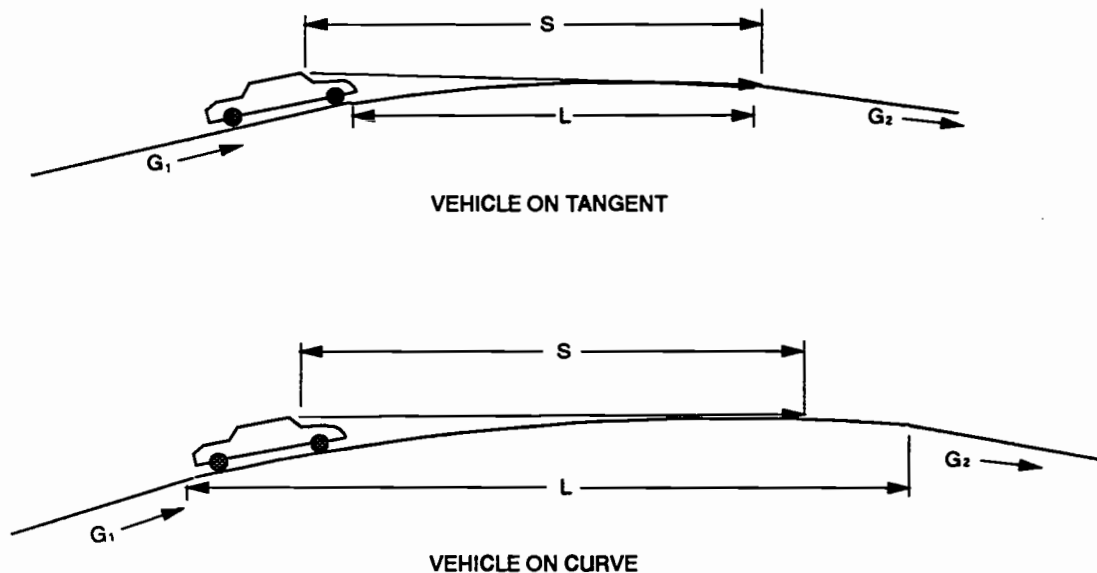
$$L = A \frac{S^2}{700}$$

With:

$L$  = length of vertical curve (ft).

$S$  = safe stopping distance (ft).

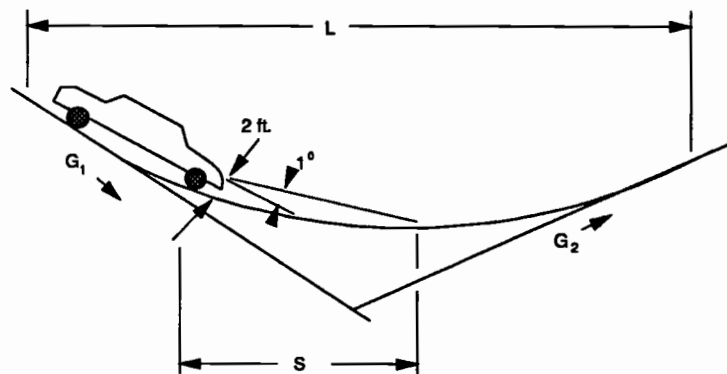
$A$  = algebraic difference  $|G_2 - G_1|$  (percent).



**Figure 14. Crest Vertical Curve Road Surface Sight Distance.**

### 3.3.2.2 Sag Vertical Curves

Vehicle safe stopping distance, which corresponds to the maximum headlight distance, is generally used for design length of sag vertical curves (1). A headlight height of 2.0 ft with a  $1^\circ$  upward divergence angle is applied (Figure 15). The headlight must light a point on the road surface equal to the safe stopping distance.



**Figure 15. Sag Vertical Curve Sight Distance.**

Where:  $S < L$

$$L = \frac{AS^2}{400 + 3.5S}$$

Where:  $S > L$

$$L = 2S - \frac{400 + 3.5S}{A}$$

With:

$L$  = length of vertical curve (ft).

$S$  = safe stopping distance (ft).

$A$  = algebraic difference  $|G_2 - G_1|$  (percent).

Drainage also affects the design of sag vertical curves. Curves should be designed to have the low point of a vertical curve located before or beyond the bottom of a draw, desirably at the transition point between cut and fill (Figure 16). This is done to provide for surface runoff from a road surface at the low point of the vertical curve prior to reaching the fill directly over a draw. This tends to reduce sedimentation carried directly into a draw or stream channel.

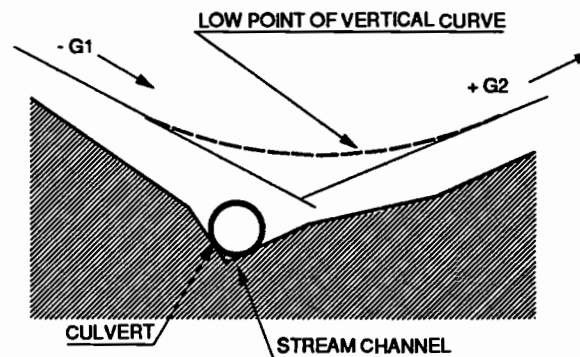


Figure 16. Vertical Curve Low Point Over Stream Channels.

### 3.3.3 Steep Road Grades on One-Lane Resource Development Roads

On low volume, resource development roads, road gradient is often the predominant design element effecting speed, vehicle operating costs, and environmental impacts associated with erosion. Adverse effects of steeper grades can become significant when grades exceed 16 percent are not properly designed and located.

In some states, laws govern maximum gradient on low volume roads. In the states of Oregon (16) and Washington (17), the maximum road grade for all resource development roads is 20 percent if loaded trucks are unassisted in negotiating the grade. On grades in excess of 20 percent it is required that an assist vehicle be available to assist loaded trucks.

Steep adverse grades are often required on local resource development roads to access resources, such as timber harvest areas. Steep grades gain elevation faster than flatter grades, and thereby shorten a length of road necessary to meet a control point, such as a ridge point or log landing. The need for steep grades in mountainous areas is often driven by two factors: the necessity of reducing risks of mass soil movement associated with roads, and the high cost of hauling road construction excavation waste material to suitable disposal sites.

The elevation difference that must be overcome on a roadway determines the amount of fuel that is consumed. The energy required is equal to the work that must be done. The equation to express this work :

$$Work = (GVW)(G)(L) = ft - lb$$

Where:

$GVW$  = gross vehicle weight (lb).

$G$  = percent road grade over grade length  $L$  (decimal percent).

$L$  = length of grade (ft).

The use of steep grades on low volume timber harvest roads is a common practice in certain locations in the Western U.S. Several temporary resource development roads with grades from 16-25 percent, have been successfully constructed, operated on, and maintained. This has been successfully demonstrated on the U.S.D.A. Forest Service Siuslaw National Forest, Mapleton Ranger District (18). Specific engineering criteria have been established and implemented for route location, design, construction, operations, and maintenance on steep road grades.

A road grade in excess of 16 percent is considered steep and requires the application of specific criteria. This includes specifications for the design of road grade, travel surface width, ditch width and depth, subgrade compaction specifications, road surfacing material specifications, road surface template, culvert size and spacing, road maintenance, and vehicle operations.

Control of drainage runoff is a critical factor on steep road grades. Relief ditch culvert spacing is decreased on steep grades. On grades steeper than 16 percent culverts are spaced at half the design interval for grades of 10 percent (18). Culvert spacing is determined by analysis of site specific conditions. It is assumed that every other culvert will plug and not function during an intense precipitation event. Ditches, where required, are constructed 0.5 ft deep and 1 ft wide. The shallow ditch is used to accommodate vehicle off-tracking. A vehicle can off-track into the ditch, and the ditch is repaired when operations are completed. Steep road grade design elements and standards used by the Mapleton Ranger District (18) are in Table 17.

**Table 17. Steep Road Grade Design Standards.**

Road Grade (%)	Subgrade Compaction % of AASHTO T-99	Surface Rock Dense Gradation Spec.	Surface Width (ft)	Surface Crown (%)	Curve Super Elev. (%)	Curve Reverse Super Elev. (%)
<16	85	2 in minus or open graded	12	4-6	4-6	---
16-18	95	1 1/2 in minus	14	4-6	4-6	---
18-20	95	1 1/2 in minus	15	4-6	---	4-6
21-25	95	1 in minus	15	6	---	6
>25	95	1 in minus	16	6	---	6

Under ideal conditions, a modern log truck can climb, unassisted, a maximum adverse grade of 34 percent, according to P. Anderson, et al. (19). Factors affecting log truck travel performance on steep grades are: net engine torque transferred to a tractor unit drive axles, friction factor between tires and road surface, the climbing grade seen by the log truck power train, gross vehicle weight, and the truck load distribution over the drive axles.

On adverse road grades in excess of 18 percent, reverse superelevation is designed into horizontal switchback curves to reduce the adverse effects of normal superelevation (Table 17) (18). Reverse superelevation assists in balancing a truck load on the tractor drive axles, increasing tire traction. Reverse superelevation also reduces the combine effects of road surface grade and normal superelevation that a truck tractor must pull a trailer through when off-tracking through a curve.

Another major factor in truck performance on steep road grades is the tire to road surface friction factor. Well compacted, dense granular soils provide a high tire to road surface friction factor under ideal moisture conditions for summer haul. On the Mapleton Ranger District, this type of surfacing has been applied successfully on steep grades. On all-weather roads, three gradations of crushed aggregate are used for surfacing steep grades (Table 18) (18).

**Table 18. Surfacing Aggregate Specifications.**

Sieve Size	Percent Passing (AASHTO T-11 and T-27)		
	2 In Minus	1-1/2 in. Minus	1 In Minus
2-in.	100	--	--
1-1/2-in.	--	100	--
1-in.	60-90	--	100
3/4-in.	--	60-90	70-98
1/2-in.	44-70	--	--
No. 4	28-50	30-55	36-60
No. 8	20-41	22-43	25-47
No. 3	9-26	11-27	12-31
No. 20	3-12	3-15	3-15

On the Mapleton Ranger District logging traffic has operated successfully on adverse road grades up to 25 percent and on vertical curves with an algebraic difference in grade of 43 percent. Log trucks with reduced tire pressure, 65 psi, have operated on adverse grades up to 23 percent without requiring additional power from an assist vehicle.

Turnouts are designed to fit the topography with minimum excavation and are not spaced at specific design intervals. For traffic control, mile posts are set at 0.5 mi intervals to facilitate citizen band radio traffic control. On crest vertical curves with restricted sight distance, 15 ft high snow poles with reflectors are placed on each side of the road to guide truck drivers. To provide adequate truck driver safety and comfort, road surface travel width varies from 12-16 ft with increasing steepness of grade (Table 17).

Road maintenance and traffic control are critical functions on road sections with steep grades. Proper road surface geometry must be maintained to prevent serious rutting and erosion during periods of high precipitation. Ditch and cross drain culvert maintenance are also important during these periods. Often traffic is restricted when commercial haul is underway. This is accomplished with proper signing, the use of flag people with radios, and gate closures.

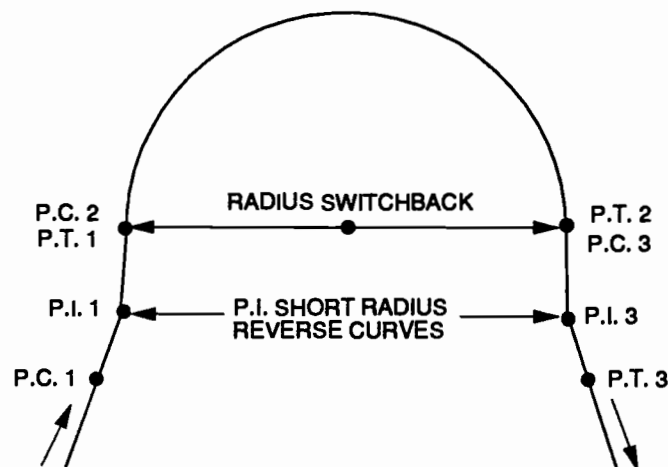


### 3.3.4 Switchback Curve Design

Switchback curves are short radius horizontal curves with large deflection angles. They are used to gain elevation in short distances. Switchback curve design methodology is not well documented and is not addressed in the AASHTO Green Book (1). Switchback curve design is not addressed in detail in the U.S.F.S Preconstruction Handbook (2). Switchback curve location and design data have been developed by Kramer (20).

Proper switchback curve location is essential to a successful design, as a designer has limited design latitude where maximum grades are approached. In developing design standards for short radius switchback curves on steep grades, the following design elements must be considered; the design and critical vehicles must be considered for vehicle operating limitations such as, off-tracking, horizontal vehicle clearance, grade, superelevation, and surfacing.

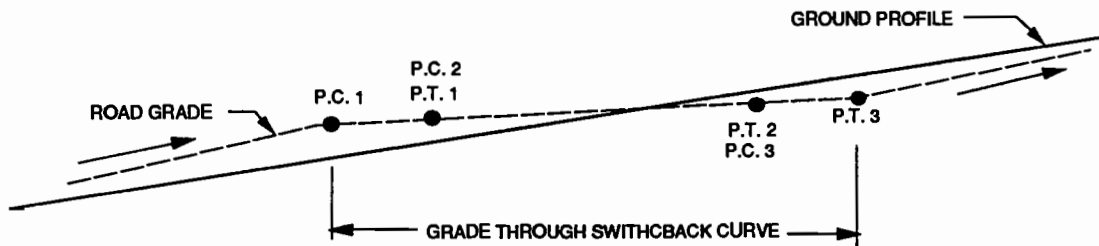
On a switchback curve location, short radius reverse curves can be designed at the P.C. and P.T. of the switchback curve (Figure 17). The short radius reverse curves enable a truck trailer to off-track to the outside of the switchback curve as the vehicle enters the switchback curve, reducing off-tracking effect as it passes through the curve.



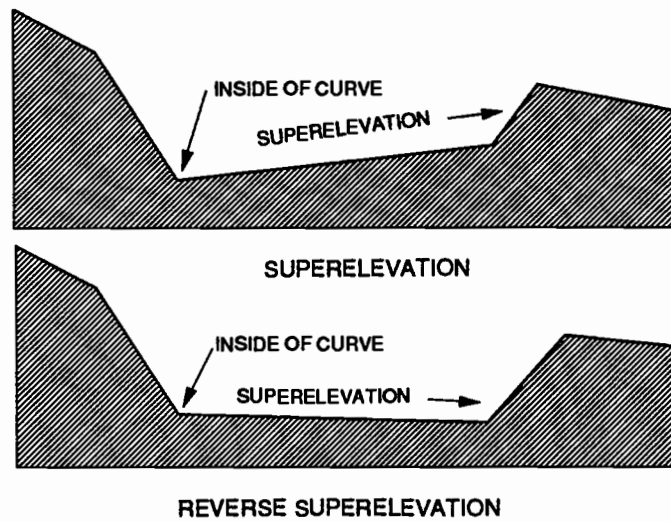
**Figure 17. Example Plan View of a Switchback Curve.**

At or near maximum grade, grade through a switchback curve should be slackened to reduce the combined effect of the grade plus superelevation on the curve that a vehicle's drive train must work against. Generally, the grade is slackened through a

switchback curve 2 to 6 percent (Figure 18). When this condition can not be met, reverse superelevation can be designed into the curve to accomplish the same effect (Figure 19).



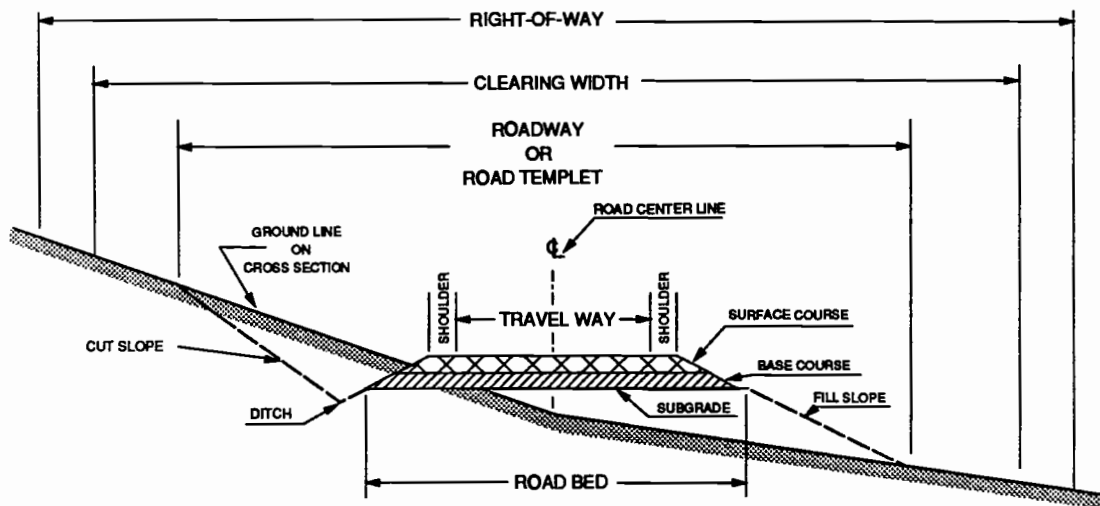
**Figure 18. Profile and Grade Through a Switchback Curve.**



**Figure 19. Road Surface Superelevation on a Switchback.**

### 3.4 Road Templet Design Standards

A road templet includes all dimensions of a road in a cross section view (Figure 20). These standards are determined based on the functional class of a road (1) or through traffic service level analysis (2).



**Figure 20. Road Templet Terminology.**

### 3.4.1 Lane Width

Lane width is determined by design speed, design vehicle and anticipated vehicular traffic. The lane width for a one-lane road should not exceed 14 ft, as drivers tend to use the facility as a two-lane road, causing potential safety problems. The AASHTO Green Book (1) suggests the following lane and shoulder widths in Table 19.

**Table 19. Lane Widths.**

Road Type	Traveled Way Width (ft)
Arterial Road (two-lanes)	11-12
Collector Road (two-lanes)	10-11
Local Road (one-lane)	12

Lane width for two-lane and one-lane, two-directional roads is based on size and type of vehicle, road type, surface material, cross slope, with or without ditch, and design speed. This information is in Table 19, Table 20, Table 21, and Table 22 (2).

Table 20. Lane Width for Two-Lane Roads.

Vehicle Type and Size	Road Type	Surface Type	Design Speed (MPM)				
			10	20	30	40	50
			Min. Lane Width (ft)				
Recreation, Service Vehicles							
Up to 6.5 ft width	Recreation	All	9	9	10	11	11
6.5 ft to 8.0 ft width	Service	All	10	10	11	11	11
Commercial Vehicles	Commercial or Mixed Traffic	Aggregate	11	11	12	12	12
		Bituminous	11	11	11	11	12

Table 21. Two-lane Width, Off-Highway Log Trucks.

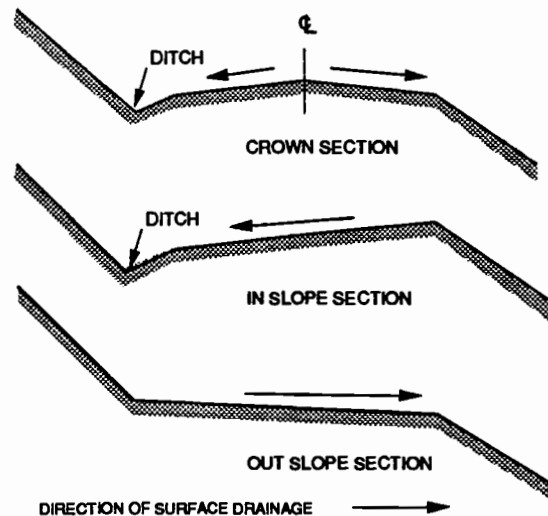
Log Truck Bunk Width (ft)	Min. Traveled way width (ft) for Design Speed (mph)		
	20	30	40
10	22	24	26
12	26	28	28

Table 22. Lane Widths for One-Lane Roads.

Type and Size of Vehicle	Design Speed (mph)		
	≤ 20	25	30
	Min. Lane Width (ft)		
Recreation, administrative and service vehicles 6.5 ft to 8.0 ft wide	10	10	12
Commercial and all recreational ≥ 8.0 ft			
Road with or without ditch with ground cross slope, < 25%.	12	12	14
Road without ditch and cross slope > 25%.	12	14	14

### 3.4.2 Road Surface Templates

Road surface slope provides surface drainage and superelevation for vehicle control. Three road surface templates are used in low volume road design; crowned, in-slope and out-slope (Figure 21). Crown is used on both two-lane and one-lane roads. The in-slope and out-slope template is generally used on one-lane roads.



**Figure 21. Road Surface Templates.**

A crowned surface template is used on two-lane and one-lane road section tangents with ditches. This template requires a ditch for surface drainage. The crown diverts one half the surface runoff to each side of the road.

The in-slope surface template carries surface runoff to the inside of the roadway to a ditch. This template is also used in superelevation design on horizontal curves.

The out-sloped surface template carries surface runoff to the outside of the road surface. The out-sloped template is generally 4 to 6 percent. On low speed low volume roads, less than 20 mph, this template can be used to eliminate the need of cross-drain ditch and culverts which reduces construction and maintenance costs. A road designed with this surface template is "self-maintaining", as there is no ditch to maintain and minimal surface erosion occurs when the water is carried off a road surface in a short distance.

Out-slope surface design is not recommended for use on road sections with grades greater than 9 percent. Out-sloped road grades that are greater than 9 percent tend to channel surface runoff on a road surface when small irregularities occur in the surfacing. This condition can cause accelerated road surface erosion.

Out-sloped roads can be a safety hazard for vehicle travel during inclement weather conditions when tire traction is reduced because of the adverse cross-slope and reduced tire to surface friction. In some locations this surface templet is not used in road designed for general public recreation traffic. Many recreation drivers have little experience driving on this type of road. Thus, for driver safety and comfort this surface templet is not used.

### 3.4.3 Shoulders

Shoulders are necessary for many purposes related to safety; recovery zone for vehicles straying off a traveled way where risk analysis justifies the cost, support of the outside edge of an asphalt pavement, guard rail installation, sign installation, accommodation of the critical vehicle off-tracking, parking for disabled vehicles, and parking for recreation activities. Often, shoulder widths are minimal on recreation and resource development roads in mountainous terrain due to construction costs and environmental impacts.

Dimensions given in the U.S.F.S. Preconstruction Handbook (2) for shoulder parking are 8 to 10 ft width with variable length, and 1 to 2 ft for support of a outside road surfacing edge. Shoulder widths given in the AASHTO Green Book (1) are in Table 23.

**Table 23. Shoulder Widths.**

Type	Shoulder Width (ft)
Primary Access Road (two-lanes)	2-4
Collector Road (two-lanes)	0-2
Local Road (one-lane)	0-1

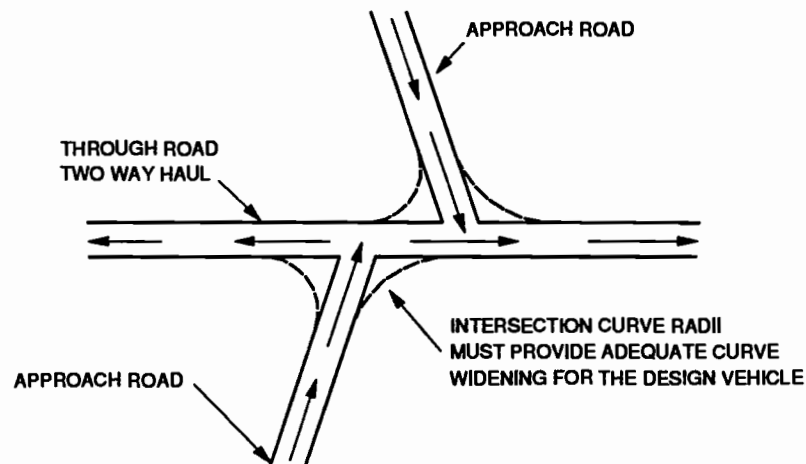
### 3.4.4 Cut and Fill Slopes

On recreation and resource development roads in mountainous terrain, cut and fill slopes are generally designed to be as steep as possible. Factors determining slope steepness are slope failure, erosion potential, and height to minimize the impact or scar on a landscape. Safe stopping distance, sight distance and horizontal clearance for resource development equipment are design considerations for cut slope steepness.

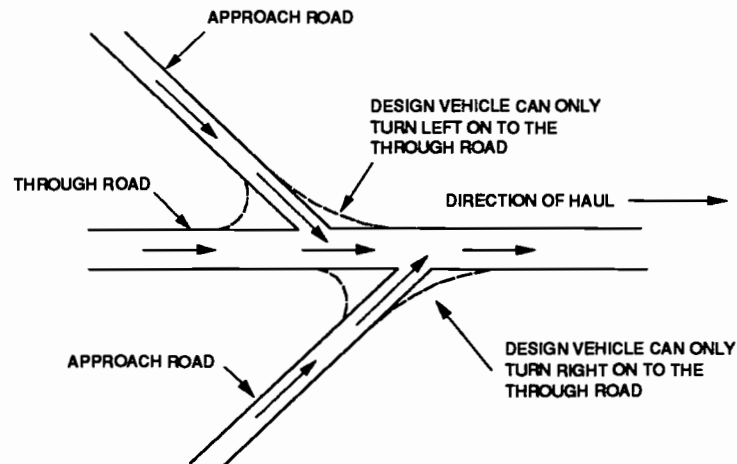
### 3.5 One-Lane Intersections

Intersections must be designed for vehicle safety, to accommodate vehicle turning, and to provide proper road surface drainage. On low volume road intersections, intersecting road angles should not be less than approximately 60 degrees when resource development traffic, such as tractor trailer combinations or log haul traffic, must turn on and off an approach road from both directions on a through road (Figure 22). Road intersection angles can be less than 60 degrees when the direction of haul is one-way off an approach road onto a through road. Figure 23 illustrates a one lane road intersection designed for one-way log haul.

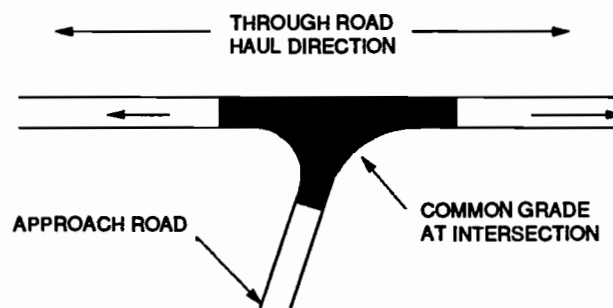
When possible, the grade of an approach road should be as flat as possible, between 2 and 6 percent. The intersection grade of both roads should be the same until adequate horizontal separation is achieved (Figure 24). If vertical curves are required at the ends of approach grade separations, a common grade should be carried for enough distance to accomplish this without having a vertical curve in an intersection. Vertical curves should be considered if grade breaks exceed 5 percent in intersections.



**Figure 22. Intersection Geometry for Two-way Haul.**



**Figure 23. Intersection Geometry for One-way Log Haul.**



**Figure 24. Common Grade at Intersections.**

### 3.6 One-Lane Turnouts

Turnouts are designed for one-lane, two-directional roads to facilitate vehicle passage. They are designed on tangents and horizontal curves. On roads designed for commercial resource development vehicles, such as log trucks, to the extent possible, turnouts are designed to maximize speed in the direction of haul.

Turnout location design must consider safety and economics. Two-lane road sections should be considered on road alignments necessitating many turnouts in short distances. Turnouts are normally located on the outside of cuts; as on the outside of a curve around a point of a ridge, low side of fills, and the point between the run out point between through cuts and fills. Turnouts may also be used to provide openings for viewing of scenic vistas.



Sight clearance between intervisible turnouts must be designed. When analyzing sight distance between turnouts, the clearing of timber and brush must be considered. On topography with steep cross slopes, with heavy brush or timber, brush maintenance for sight distance can be a costly operation if wide clearing areas are required.

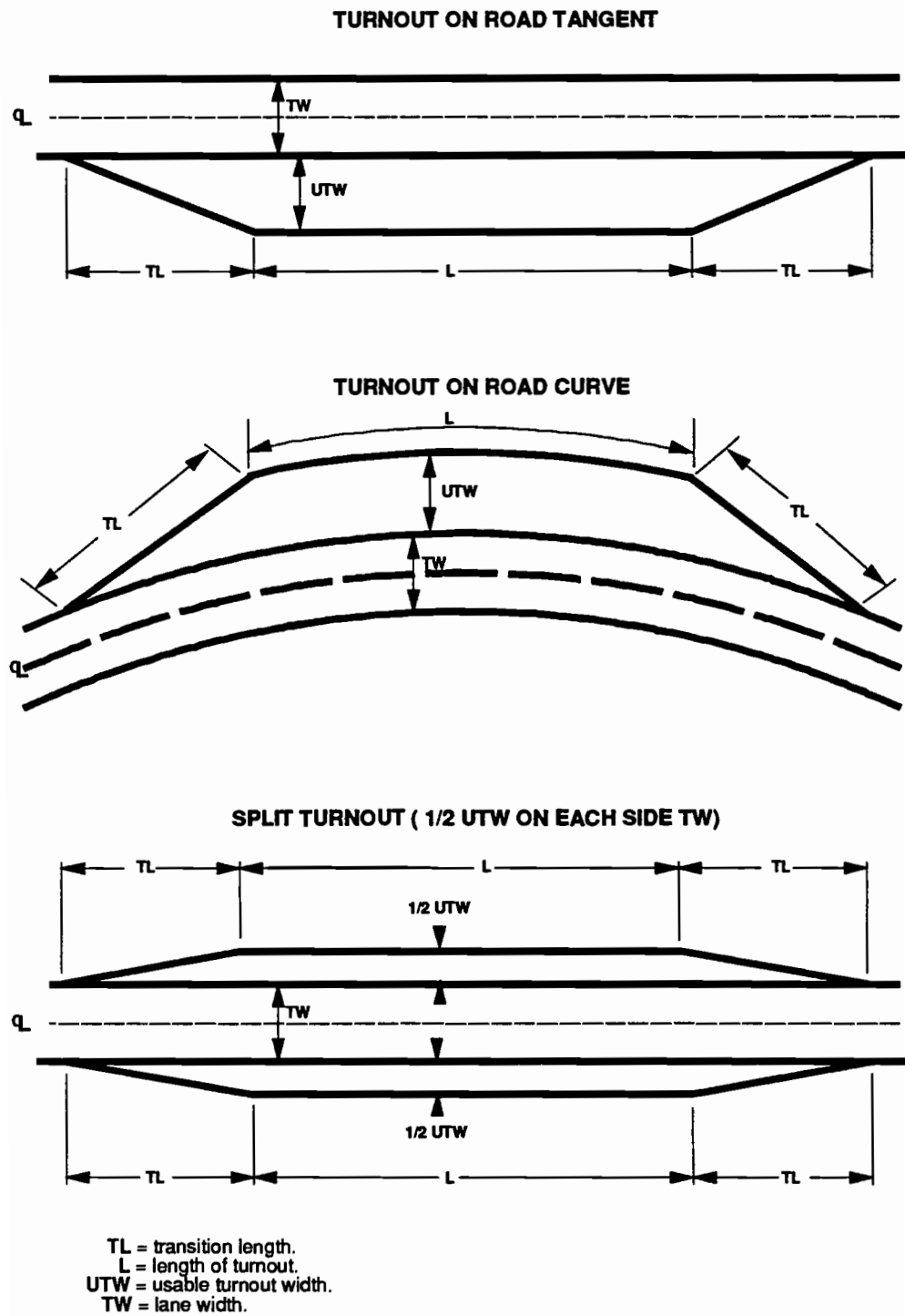
On one-lane, two-directional local resource development roads that have traffic control limited to resource development traffic, non-intervisible turnouts can be designed if alternate controls are used, such as mile posting and the use of citizen band radio communications.

Turnout design criteria are given by both the AASHTO Green Book (1) and the U.S.F.S. Preconstruction Handbook (2). The only criteria given in the AASHTO Green Book (1) is, a maximum turnout intervisible distance to 1,000 ft and the data in Table 24.

**Table 24. AASHTO One-Lane Road Turnout Design Dimensions.**

Lane Width (ft)	Turnout Width (ft)	Turnout Length (ft)	Transition Length (ft)
12	10	100	50
14	10	100	50

Turnout dimension geometry is illustrated in Figure 25 (2). On one-lane, two-directional roads with resource development traffic, turnouts should be designed on the side of the road that is advantageous to empty vehicles. This precludes a loaded truck from being forced to reduce speed in the direction of haul. The split turnout is advantageous when balancing earthwork and providing the equivalent of a two-lane section for vehicle passage. Turnout requirements and dimensions based of traffic service levels are in Table 25, and Table 26 (2).



**Figure 25. Turnout Design Geometry.**

Table 25. One-Lane Road Turnout Requirements.

Traffic Service Level	Turnout Spacing	Operational Constraints
A	Intervisible turnouts Maximum 1,000 ft spacing	Traffic: mixed Capacity: $\leq 25$ vph Design speed: $\leq 40$ mph Delays: $\leq 20$ sec/mi
B	Intervisible turnouts desirable, may be precluded by excessive cost or environmental constraints. Maximum 1,000 ft spacing	Traffic: mixed Capacity: $\leq 25$ vpd Design speed: $\leq 25$ mph Delays: $\leq 30$ sec/mi Road segments w/o turnouts should be signed.
C	Maximum 1,000 ft spacing	Traffic: small amount of mixed. Capacity: $\leq 20$ vph Design speed: $\leq 20$ mph Delays: $\leq 60$ sec/mi Road managed to minimize conflicts between commercial and noncommercial traffic.
D	Turnouts at locations with minimum cut or fill	Traffic: not intended for mixed. Capacity: $\leq 10$ vph Design speed: $\leq 15$ mph Delays: $\leq 60$ sec/mi Traffic restricted to single purpose use.

Table 26. One-Lane Road Turnout Dimensions.

Traffic Service Level	Turnout Width (ft)	Turnout Length (ft)	Minimum Transition Length (ft)
A	10	Length of design vehicle or 75 ft whichever is greater.	50
B	10	Design vehicle length.	50
C	Min. tot. traveled way width and turnout equal to max. out to out width of design vehicle plus 4 ft.	Design vehicle length.	25
D	Min. tot. traveled way width and turnout equal to max. out to out width of design vehicle plus 4 ft.	Empty log truck length	25

Cost, safety, and traffic delays must be considered when determining turnout spacing. The U.S.F.S. Preconstruction Handbook (2) gives traffic delays as primary criteria for setting turnout spacing. Delay time, ( $T$ ) in percent, is determined by the equation:

$$T = \frac{DS}{36}$$

Where:

$D$  = delay time per mile for interrupted vehicles  
(sec), (Figure 26).

$S$  = design speed (mph).

Turnout spacing, as a function of percent delay time and number of vehicles per hour (VPH), is determined in Figure 26 (2). Turnout spacing is computed for 250 ft to 1,000 ft.

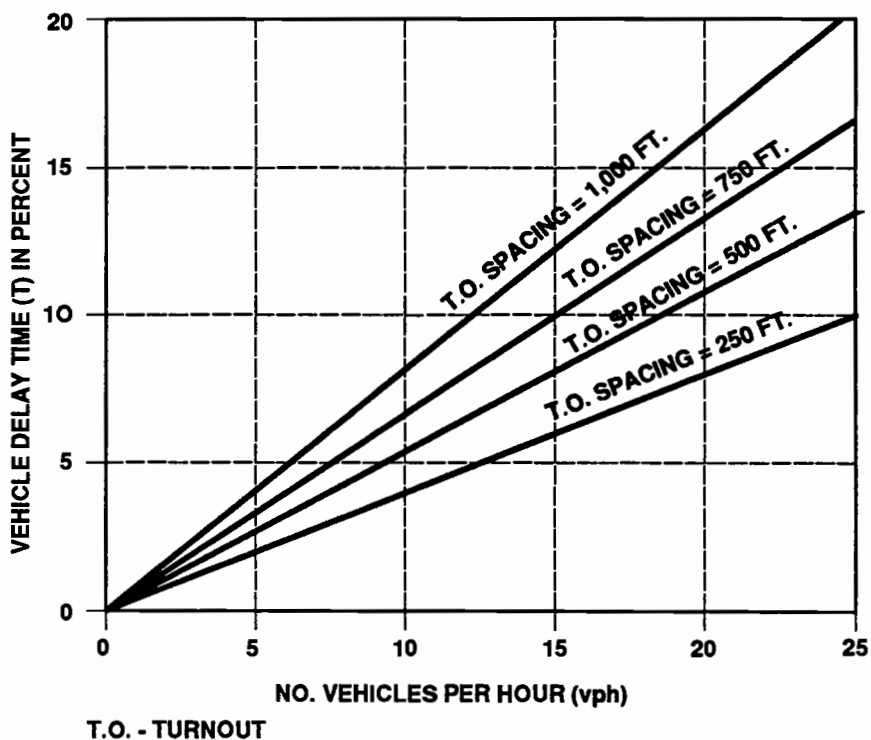


Figure 26. One-Lane Road Turnout Spacing.

### 3.7 Road Drainage

Properly designed road drainage is "paramount" to a road's structural integrity. Poorly drained roads cause safety problems, increased user costs, higher maintenance costs, and environmental problems. The key to successful road drainage is to channel all water away from a roadway as soon as possible, preventing water from penetrating a road surface and subgrade, thus weakening the subgrade and causing surface and subgrade failure.

#### 3.7.1 Surface Drainage

Proper surface drainage design provides for surface water to be taken off a road surface as soon as possible. This is accomplished with a crown, in-slope, or out-slope surface templet (Figure 21). On aggregate or native soil surfaced roads, grades in excess of 10 percent should not be carried for long distances. Rutting can carry surface water, eroding the surface and saturating surface and subgrade material, causing serious maintenance problems.

#### 3.7.2 Ditches

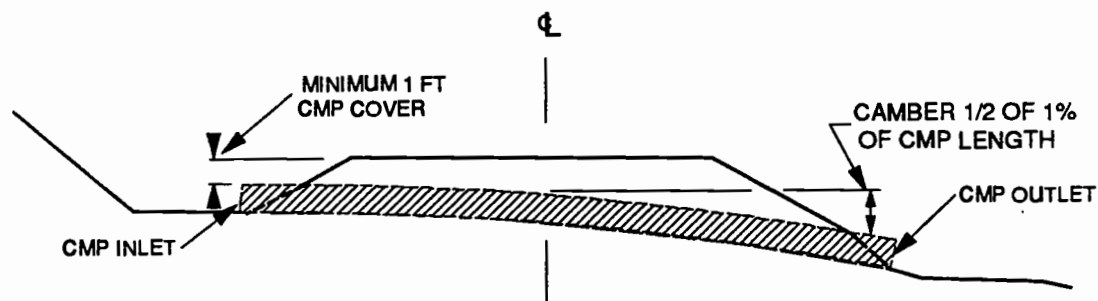
Roadway ditches intercept road surface runoff, overland surface runoff, and subsurface water. Ditch runoff is intercepted by cross drain culverts and carried away from the outside roadway slope. Ditch grades should not be less than 2 percent to assure water flow. Standing water in ditches can infiltrate the subgrade and cause reduced structural strength. If subgrade saturation occurs, there can be a risk of mass soil movement. Ditch dimensions, depth and width, vary depending on the design volume of intercepted runoff, *Hydraulic Manual*, Oregon Department of Transportation (21).

#### 3.7.3 Ditch Relief Culverts

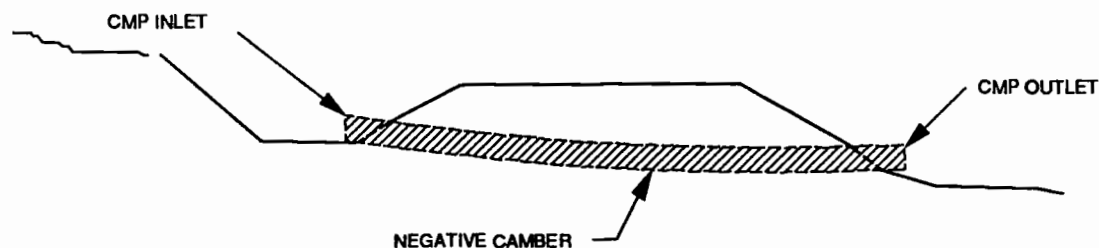
Lateral ditch relief culverts are used to carry water from ditches under the roadbed to the outside road slope. Ditch relief culverts are designed at design intervals on grade and at the low point of vertical curves. The interval at which culverts are placed on grade depends on the percent grade, erodibility of ditch material, and design ditch flow volume. Culverts are placed at closer intervals as grades steepen and/or the ditch material becomes more erodible. Culvert installations are generally designed with a 3-4 ft flat bottom catch basin. At the subgrade shoulder at a culvert location on the ditch foreslope there should be a minimum cover over the top of the

corrugated metal culverts (CMP) of one half the culvert diameter or 1 ft, which ever is greater (Figure 27). This minimum cover depth precludes damage to a culvert inlet caused by heavy construction equipment passing over it.

A ditch relief culvert grade should be designed at the ditch grade and be less than a negative 2 percent. This is necessary to prevent siltation and inlet blockage. A positive camber on the lower one half of a culvert installation length should be considered in design where a culvert is to be installed in common fill material (Figure 27). A culvert will sag vertically when common fill material consolidates under the culvert. This condition will cause a low point in the culvert which tends to accumulate silt and debris (Figure 28). To compensate for the potential displacement, positive camber is designed into a culvert trench bed by increasing the lower half of the trench bed slope 1/2 of 1 percent of the culvert length, Figure 27.

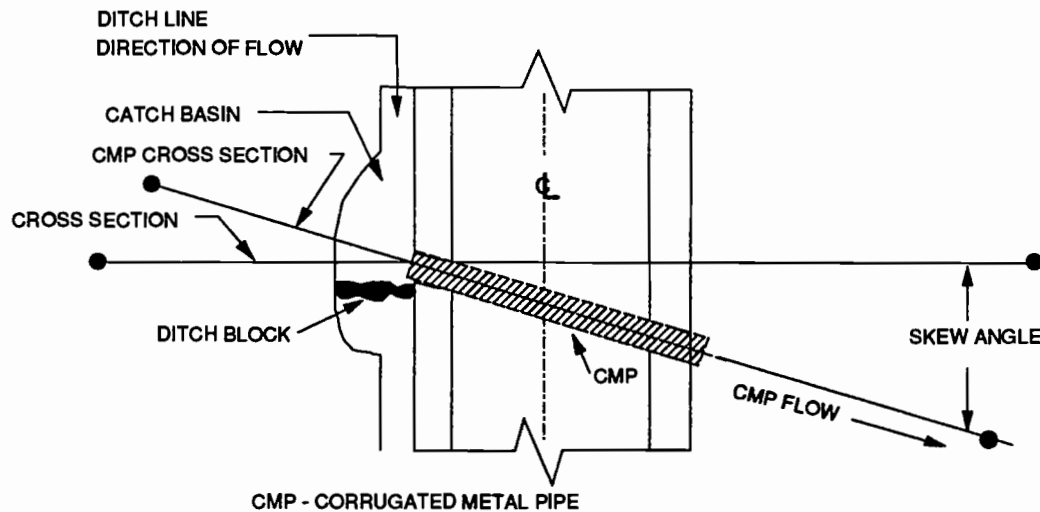


**Figure 27. Ditch Relief Culvert Design.**



**Figure 28. Culvert Installed Without Camber.**

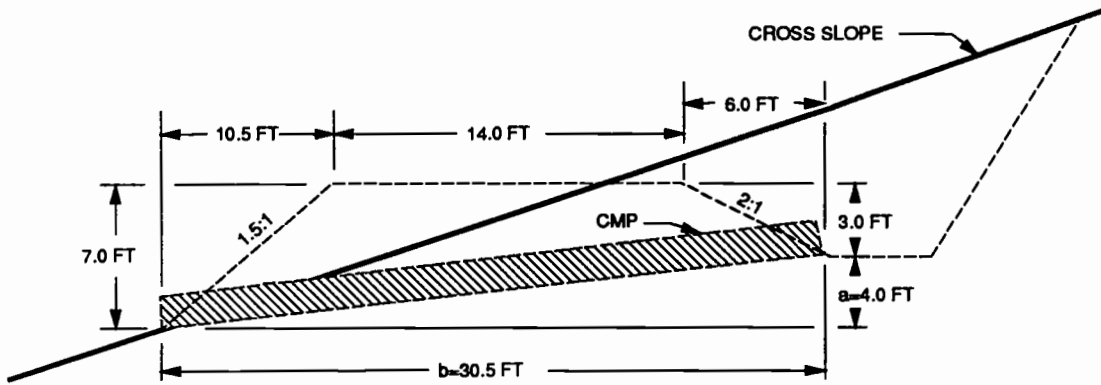
Culverts should be skewed at the inlet to avoid a right angle with the ditch. The skewed culvert entrance enhances flow and reduces siltation and debris blockage. Design skew angles are generally 20 to 45 degrees (Figure 29).



**Figure 29. Skewed Culvert.**

Culvert lengths are estimated during design, and final length measured during a construction survey. The cross section of a skewed culvert is not perpendicular to the road prism. The perpendicular cross section at the culvert location is used as a reference for a culvert design. The culvert location cross section is not surveyed until the culvert location is surveyed prior to construction (Figure 30), *Handbook for Steel Drainage and Highway Construction Products* (22).

Culvert outlets should not be designed to discharge onto common fill material. Excessive erosion can occur below a culvert outlet (Figure 31). Down spouts, full round or half round culverts, and energy dissipaters should be used (Figure 32).

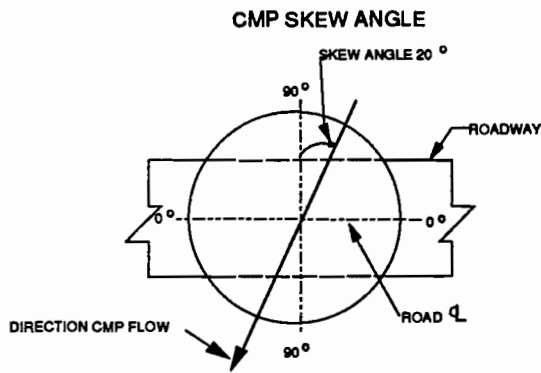


a = VERTICAL DISTANCE FROM GRADE TO CATCH POINT (FILL) MINUS VERTICAL DISTANCE FROM GRADE TO CMP INVERT.

$$7.0 - 3.0 = 4.0 \text{ FT}$$

b = HORIZONTAL DISTANCE FROM CENTERLINE TO CATCH POINT (FILL) PLUS HORIZONTAL DISTANCE FROM CENTERLINE TO CMP INVERT.

$$14.0 + 6.0 + 10.5 = 30.5 \text{ FT}$$



**EXAMPLE:**

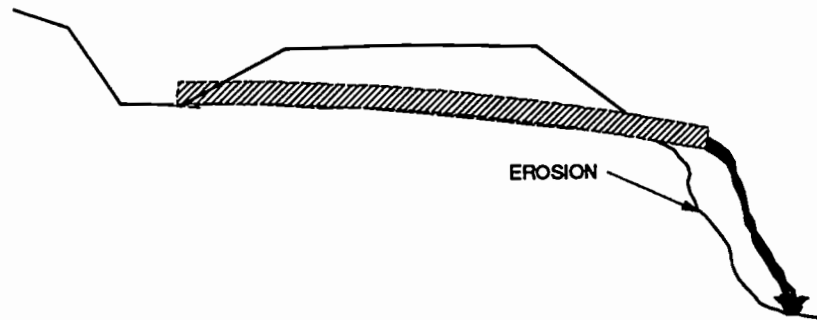
$$\begin{aligned} \text{CMP LENGTH} &= \sqrt{a^2 + b^2} \\ &= \sqrt{(4.0)^2 + (30.5)^2} \\ &= \sqrt{946.3} = 30.76 \text{ FT} \\ &\text{USE 31.0 ft. WITH NO SKEW} \end{aligned}$$

FOR CMP WITH SKEW  
 DIVIDE CMP LENGTH BY COSINE OF (SKEW ANGLE)  
 FOR SKEW = 20°  
 (31.0 ft.) / (COS 20°) = 33 FT  
 USE 36 ft. CMP LENGTH

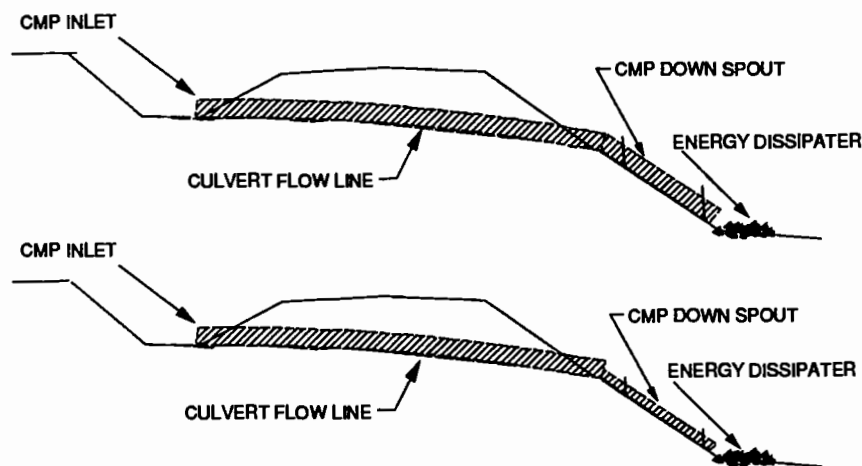
NOTE: ALLOW FOR A MINIMUM OF 2 FOOT BEYOND FILL, USING NEXT EVEN 2 FOOT LENGTH.

**Figure 30. Culvert Length Computations.**





**Figure 31. Improper Culvert Outlet Design.**



**Figure 32. Culvert Down Spout and Energy Dissipater.**

### 3.7.4 Drain Dips

Drain dips are an excellent method for taking surface runoff off of resource development roads that are out-sloped without a ditch. Limitations of this design are a maximum road grade of 9 percent with a shallow fill, not greater than 6 ft in height, in common material at the outside shoulder. Drain dips should be designed with sufficient vertical curve length and depth to permit the passage of the design and/or critical vehicle, and provide adequate diversion of road surface runoff. The low point in a drain dip and fill slope at the outfall of the low point are often armored with pit run rock of sufficient size to preclude erosion of the road surface and fill slope.

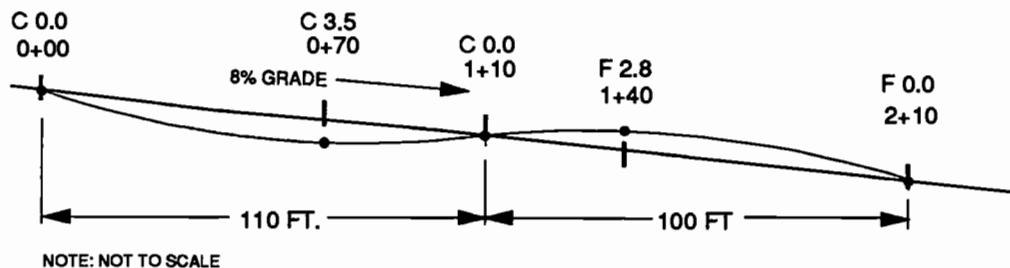
The drain dip design data, in Table 27 and Figure 33, have been successfully applied in several road designs (20). The design data in Table 27 can be applied where adequate tangent distances is provided to accommodate the 210 ft drain dip

transition length. When a tangent distance is less than 210 ft, shorter drain dip transitions must be designed. A drain dip design must provide adequate vertical clearance for the design and/or critical vehicle.

There are three advantages in using the drain dip design in Table 27; the relatively long horizontal drain dip transition permits log trucks and tractor trailer easy passage. The length, depth, and height of the sag and crest vertical curves are high enough to preclude obliteration by road surface maintenance activities. Construction staking of this drain dip design is straight forward, using the data in Table 27.

**Table 27. Drain Dip Design and Construction Staking Data.**

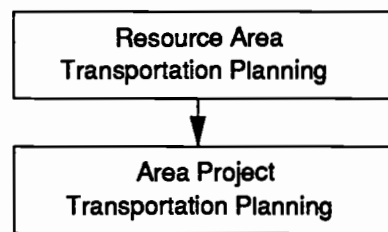
Road Grade (%)	Drain Dip Construction Stakes				
	0+00	0+70	1+10	1+40	2+10
	Cut	Cut	Cut	Fill	Fill
2-3	0.0	-1.3	0.0	+1.0	0.0
4	0.0	-2.0	0.0	+1.4	0.0
5	0.0	-2.3	0.0	+1.8	0.0
6	0.0	-2.7	0.0	+2.0	0.0
7	0.0	-3.0	0.0	+2.3	0.0
8	0.0	-3.5	0.0	+2.8	0.0



**Figure 33. Example Drain Dip Design Profile.**

#### 4 RESOURCE TRANSPORTATION PLANNING

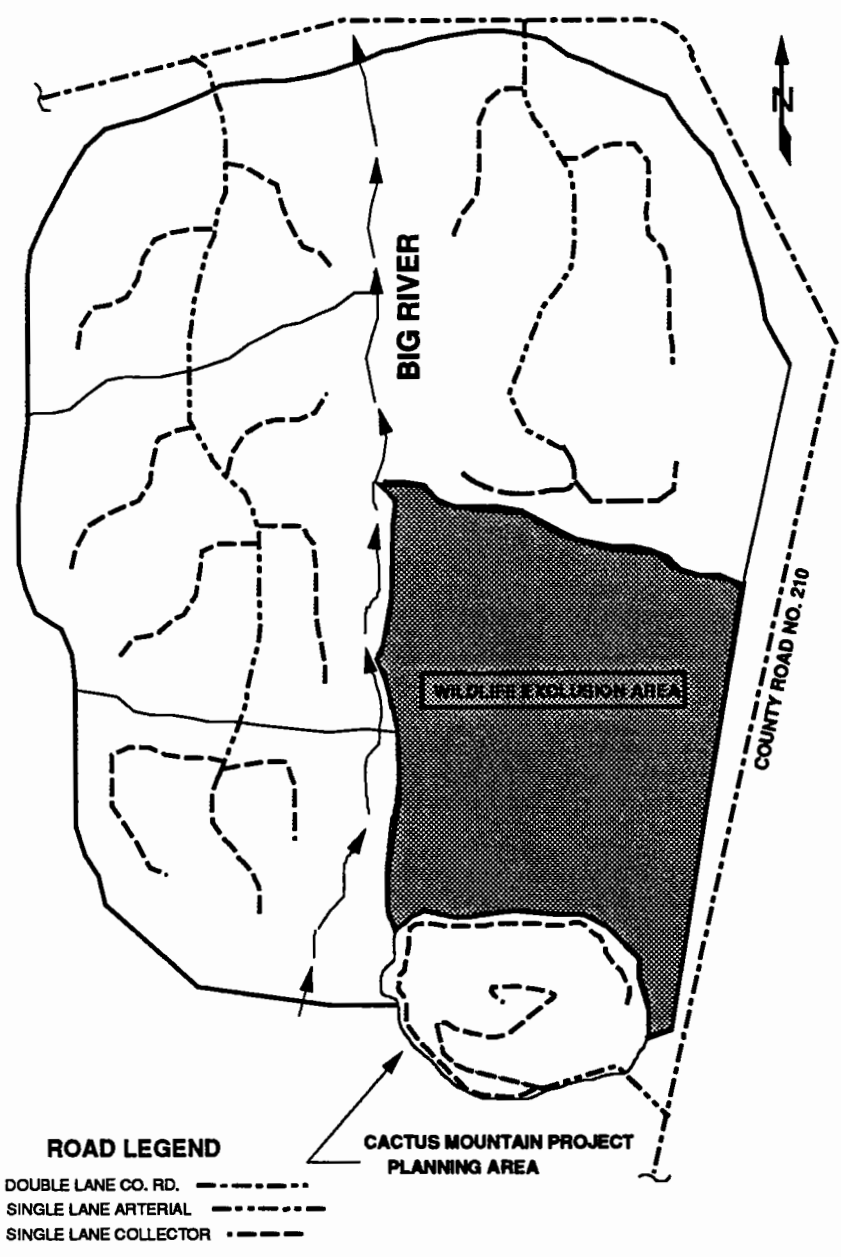
Comprehensive transportation planning within a resource planning area, such as a large contiguous forest, is the foundation of a successful, operational, resource transportation facility. Transportation facilities must provide safe, economical, and environmentally acceptable roads serving designated resource activities. There are two levels of transportation planning generally executed within a large resource planning area. The first level is resource area transportation plan which encompasses the entire resource planning area. Within this larger area, sub-area, project transportation plans are executed (Figure 34).



**Figure 34. Levels of Resource Transportation Planning.**

##### 4.1 Resource Area Transportation Planning

Resource area transportation planning is accomplished in conjunction with the development of a comprehensive resource area plan. Arterial and collector networks providing major access are planned. An example of a resource area transportation plan is illustrated in Figure 35.



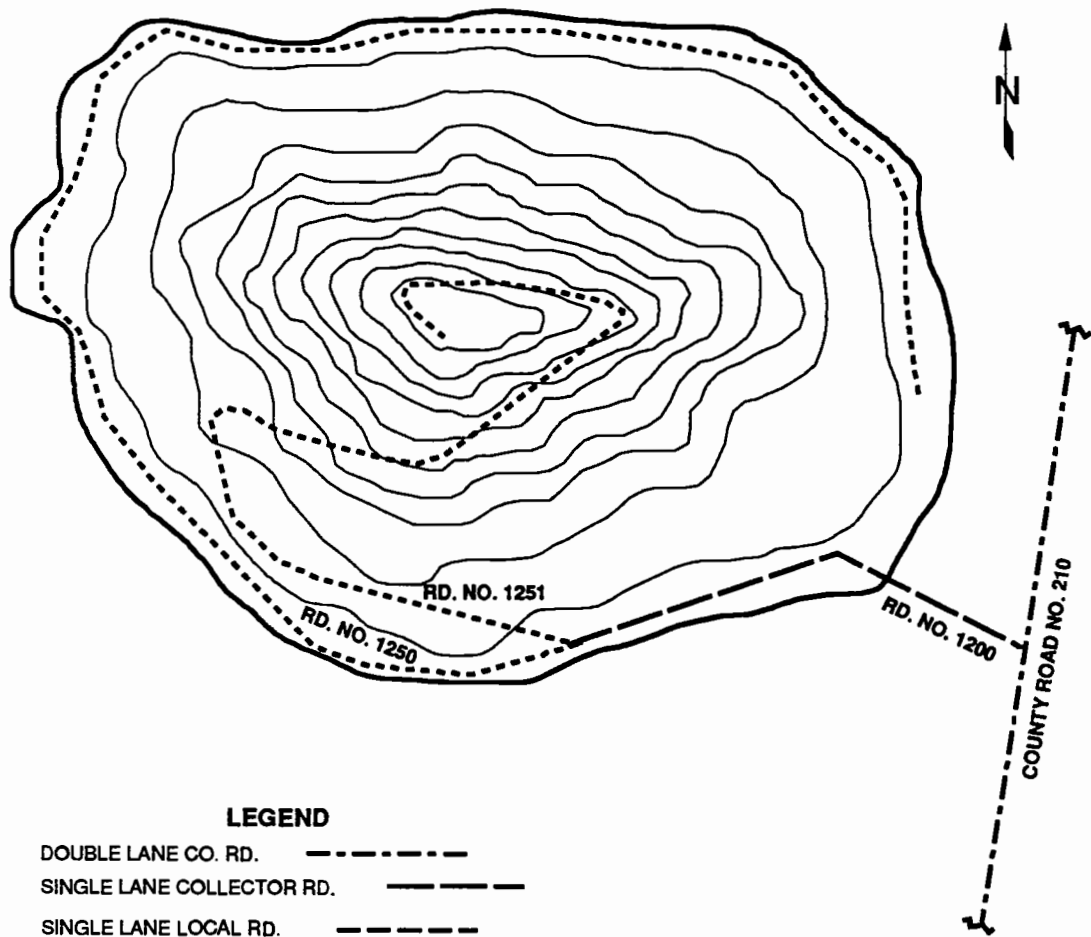
**Figure 35. Resource Area Transportation Plan Example.**

#### 4.2 Project Area Transportation Planning

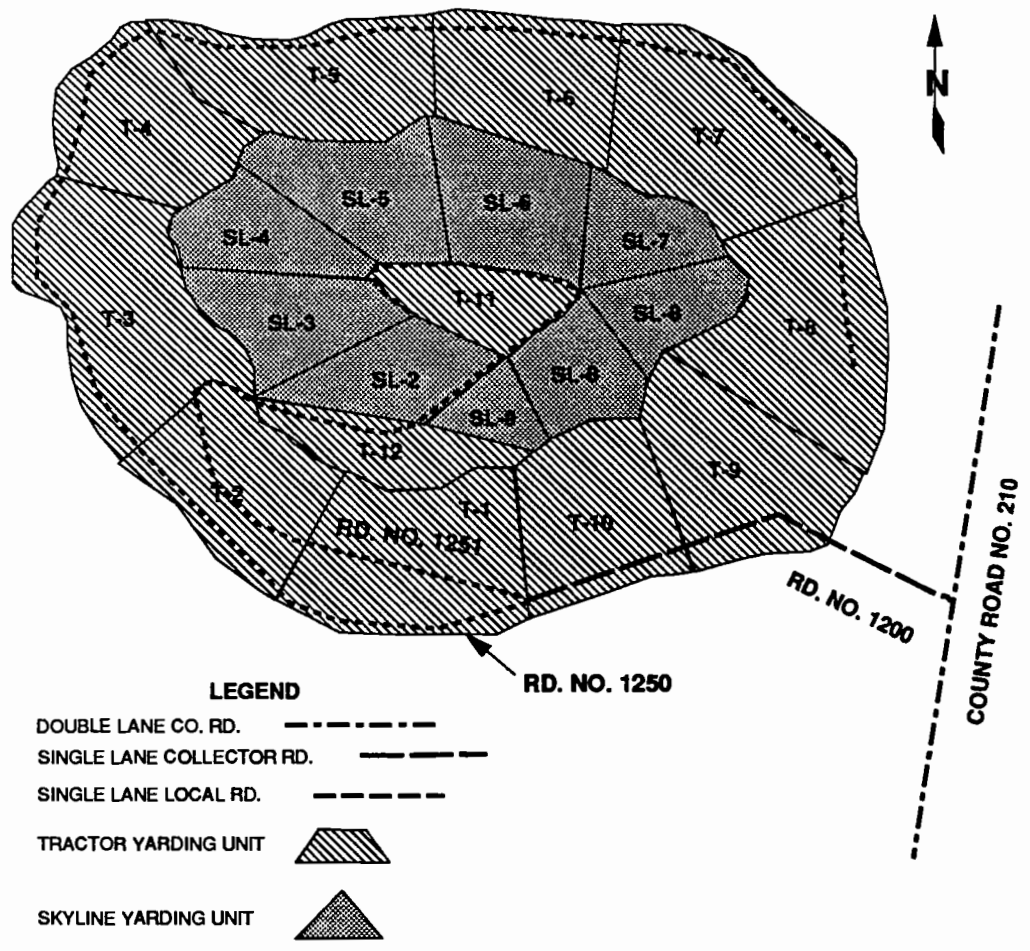
An project area transportation plan is developed within a contiguous areas inside the resource area planning unit. Detailed transportation analysis is performed at this planning level (Figure 36). Each project planning area within the resource area transportation plan is delineated by topographical features, such as ridges, rivers,

lakes, and other features such as property boundaries and existing roads. Project planning areas are also delineated by other resource constraints such as; wildlife, recreation, and areas excluded by law from development.

Local roads are planned to meet resource management objectives. It is crucial that this level of transportation planning be executed simultaneously with the planning of the area's resource development plan. The Cactus Mountain project area planning example, in Figure 36, is a contiguous area within the resource area planning unit. For example, the Cactus Mountain project planning area is planned ,by an interdisciplinary team, for winter recreation and timber resource development (Figure 36 and Figure 37).



**Figure 36. Cactus Mountain Project Area Transportation Plan.**



**Figure 37. Cactus Mountain Project Area Harvest Plan.**

Development of example road management objectives and design elements are determined for the Cactus Mountain project planning area (Figure 36). A detailed example is in Appendix A. In the example, resource management and road management objective are developed. Road design elements and standards are determined. Road design elements and standards for each road within the Cactus Mountain project area planning unit are in the appendix.

## 5 ROAD LOCATION

Proper location is essential to the development of recreation or resource development roads, particularly on difficult mountainous terrain. In many instances, traditional methods of route location, such as aerial photo location, are not feasible, particularly on steep, densely forested mountainous terrain. Thus, the road locator must locate a road, under adverse ground conditions, as closely as possible to the centerline of the road to be designed. To accomplish this objective, the road locator must have considerable knowledge of road design and construction practices.

Improperly located roads can cause difficult design problems, resulting in serious consequences such as; severe environmental impacts, higher construction costs, increased vehicle operating costs, higher than anticipated maintenance costs, and may not meet resource management objectives.

### 5.1 Required Resources for Effective Road Location

In-depth training, experience, and diversity of engineering skills are required to become a competent road locator, particularly in adverse mountainous terrain. Often the road locator does not have all the necessary skills that an ideal locator possesses. In this situation, a team concept of providing the necessary combination of skills may be advantageous. The following areas of knowledge and expertise must be available to properly locate low volume, special purpose roads under difficult site conditions requiring various resource considerations and constraints:

Aerial photo interpretation.	Survey law.
Road structures.	Logging planning.
Decision analysis.	Transportation system planning.
Engineering cost estimating.	Road surveying.
Engineering geology.	Soil mechanics.
Local forest soils.	Stream hydrology.
Geomorphology.	Surface and subsurface drainage.
Contour maps and mapping systems.	Technical report writing.
Road design.	

#### 5.1.1 Geotechnical Investigations

In areas of complex geology, soils, and/or groundwater, it is often advantageous for the road locator to acquire a second opinion regarding the suitability of a road location site. Sometimes road locators may not be completely objective, or correctly analyze, all potentially significant geotechnical problems associated with a particular

road location. Road locaters must have sufficient geotechnical knowledge to make obvious choices and recognize potential problems requiring additional geotechnical assistance.

If there are potential geotechnical problems that the road locater can not resolve, a geotechnical engineer should be consulted and retained to make a site investigation to determine whether or not the road location section in question is adequate.

#### **5.1.2 Road Reconnaissance Procedures**

Once a road corridor has been identified through the transportation planning process, the paper location must be ground verified. This is accomplished by locating the road between control points using the design criteria, elements, and standards developed during the transportation planning process.

#### **5.1.3 Resource Information for a Road Location**

Road reconnaissance begins with gathering and studying available resource information related to the area of route corridors to be planned. This information and data are often acquired from a resource area management and transportation plan. The resource information must be studied to insure that the land management objectives can be effectively met when specific routes are verified by field location.

Site specific resource information must be acquired and analyzed. This material and information include, but is not limited to; base maps, aerial photos, land use activities, property ownership, timber types, soil inventory maps, planned and existing transportation systems, and other resource data such as, archaeological sites, visual resource management objectives, and wildlife limitations.

#### **5.1.4 Field Road Location**

A road location is verified on the ground, using maps and/or aerial photo location as a guide. The road is located between control points, such as existing road intersections, stream crossings, locations of resource development, such as log landings, and recreation campgrounds. Adjustments are made on the ground, and maps and/or aerial photo locations are updated as field location reconnaissance proceeds. The road locater takes notes regarding specific site conditions that are necessary for consideration in the road design.

Specific ground conditions, given road design elements and standards, timber harvest methods, and environmental constraints dictate how road location will proceed within a given road corridor. Road design standards include:



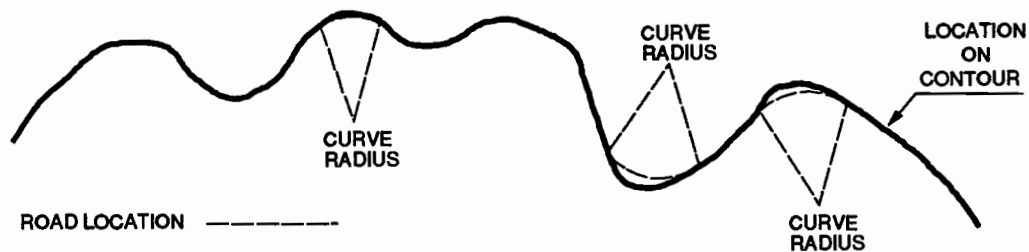
**Design elements:**

- Number of lanes.
- Road surface templet.
- Design and critical vehicles.

**Design standards:**

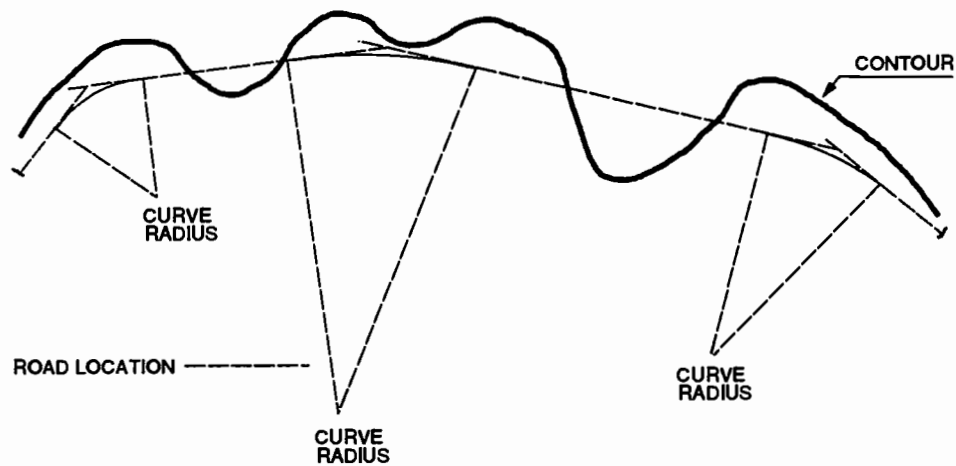
- Lane width.
- Road subgrade widths.
- Ditch dimensions.
- Cut and fill slope ratios.
- Design and critical vehicles dimensions.
- Minimum and maximum road grades.
- Minimum horizontal curve radius.
- Minimum length vertical curves.

When locating a low volume, one-lane road, ground contours will often conform to an acceptable horizontal road alignment. The natural horizontal curvature of contours is followed where the contours approximately conform to a horizontal curve radius equal to or greater than the minimum allowable curve radius. At location points where the horizontal ground contour curvature is less than the minimum allowable curve radius, the minimum design curve radius must be field located (Figure 38).



**Figure 38. Non-Geometric Road Design Location.**

On a road location requiring horizontal and vertical geometric design control (Figure 39), the road location is restricted by fixed horizontal and vertical control geometry. This type of location is generally applied in the design of two-lane roads. This alignment geometry generally creates greater cuts and fills than would be obtained by a non-geometric alignment located within the same location corridor.



**Figure 39. Geometric Road Design Location.**

## 5.2 Road Location Procedures

Roads are located between control points. Control points are ground locations a road must pass through such as; intersections with existing roads, stream site crossings, ridge saddles or points, resource extraction sites, and recreation facilities.

In terrain where side slopes exceed the maximum allowable grade limits, control points are usually sequentially connected by grade lines. Grade lines can be set with an Abney Level or Clinometer, using the percent scale (rise or fall in feet per 100 feet of horizontal distance) on either instrument.

Plastic flagging is hung on grade at eye level in trees or bushes at intervisible distances on the road location line. Notes can be written on the hung flagging to provide information for others reviewing the location and the survey line. On side slope locations, the grade line is usually run at grade-out, the point where the road subgrade intersects the ground cross-slope.

In areas of through cut or fill, the grade line is carried on the road centerline, carrying cut and fill elevations to maintain a road grade. A two-person party for grade line location is common, however, a location can be established by one-person (Figure 40). With a two-person party, the rear person sights ahead on the grade line. The second person moves ahead to the farthest intervisible distance on grade. The ahead person holds a piece of plastic flagging horizontally at the eye height of the rear instrument person running the grade line. At the direction of the instrument person, the ahead person moves up or down the side slope until the desired grade line is

established. When the second person is on grade, flagging is attached to a nearby tree or bush at the grade elevation. This procedure is repeated until two control points are joined. Grade measurements are checked by the back and ahead locator measuring the grade back and forth.

With only one-person available to locate a road, a grade line can be established by setting a grade point at eye level and then moving ahead, an intervisible distance from an established grade marker. The person then turns around, facing the previously set grade point and moves up or down the side slope, sighting on the previous grade marker until the desired grade is obtained. A piece of flagging is hung at eye level, and the procedure is repeated until the next control point is established.

With either method, grade mark ribbons should not be placed higher than eye height of the instrument person. The "grade" on the ground, then, is directly below the grade line hung on trees or bushes.

#### 5.2.1 Road Location on Centerline and at Grade-out

A road is located at grade-out or on centerline. Grade-out is the point a road subgrade intersects the cross-slope (Figure 40). At grade-out, the grade line is established along contours. When grade must be carried on locations of through cuts and fills, the road locator shifts the location from grade-out to centerline location. On centerline location, cut and fill elevations must be carried to maintain a grade. The example in Figure 40 illustrates the method of one-person carrying grade on through cut and fill sections. The steps to accomplish this are:

1. Sight ahead on grade from point 1 to point 2, carrying a 5.5 ft cut to grade. Place a piece of flagging at point 2 and move to point 3.
2. At point 3 sight back, on grade, to flagging at point 2 and place flagging on the point. Carry a 5.5 ft cut to grade.
3. Move ahead to point 4, sight back on grade to flagging at point 3 and place flagging at point 4. Carry a 5.5 ft fill. Point 3 is the road grade.
4. Move to point 5, turn sight back on grade to flagging at point 4 and place flagging on the point. Carry an 11.0 ft fill.
5. Turn at point 5, sight ahead on grade to point 6. Carry a 5.5 ft fill.
6. Move ahead to point 6, place flagging on ground and sight ahead on grade to point 7. A fill of 11.0 ft has been carried, and the locator is sighting on the road grade at point 7.
7. Move to point 7, place flagging on point and sight ahead on grade to point 8. Carry a 5.5 ft cut.

8. Move to point 8, sight ahead on grade and note sight point on tree. Tie flagging around tree at sight point 9. Measure the distance from the ribbon to the ground, 3.5 ft. At point 8 there is a 7.5 ft cut to grade,  $[(5.5 \text{ ft}) + (5.5 \text{ ft} - 3.5 \text{ ft})] = 7.5 \text{ ft}$  cut to grade at point 9.
9. Move ahead to point 10, sight back on grade at flagging on the tree at point 9, place flagging at point 10. Carry a 2.0 ft cut.
10. Move to point 11, sight back on grade to point 10, and place flagging on the point. Carry a 7.5 ft cut to the road grade.
11. Continue the location process along the road centerline.

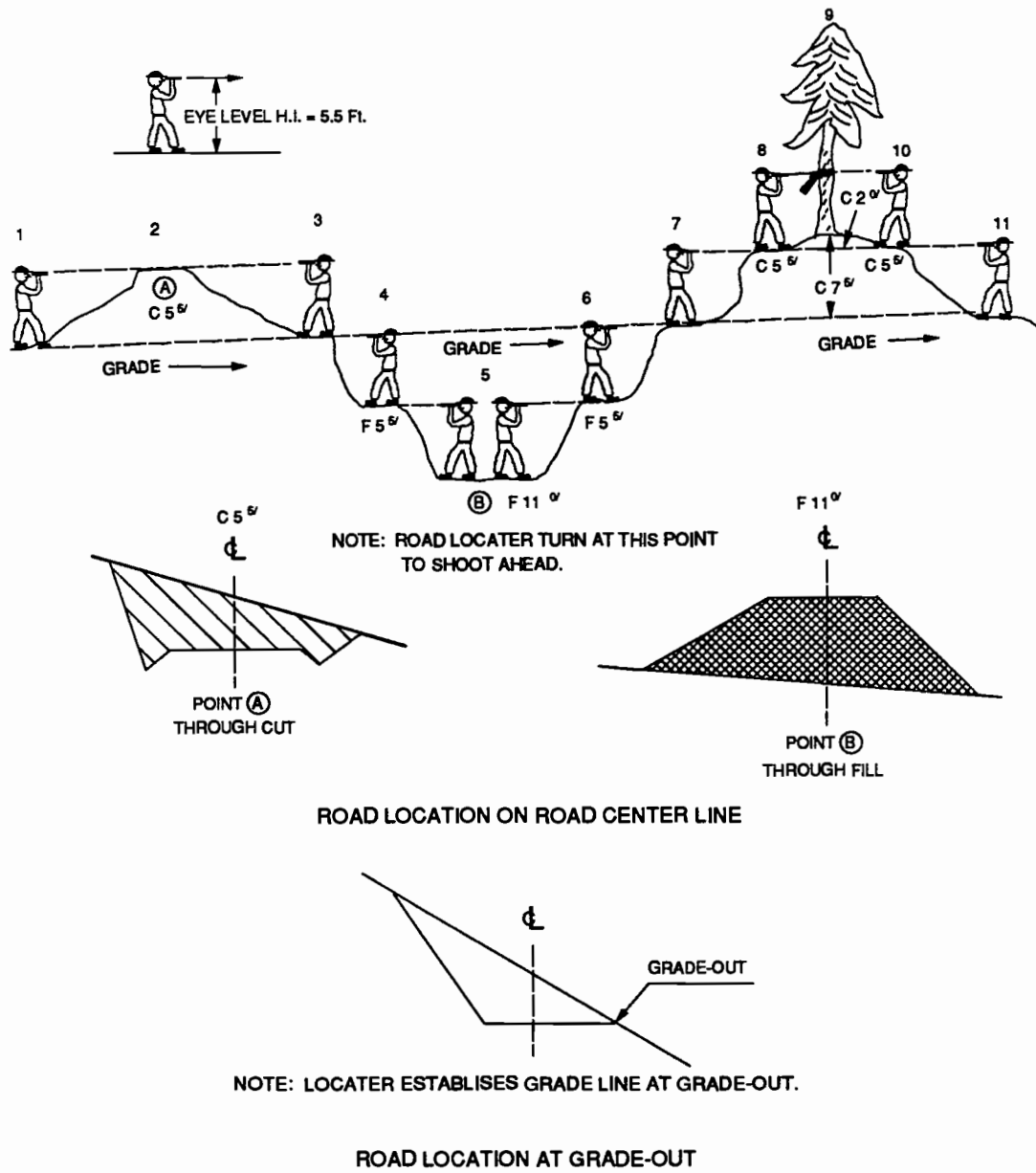
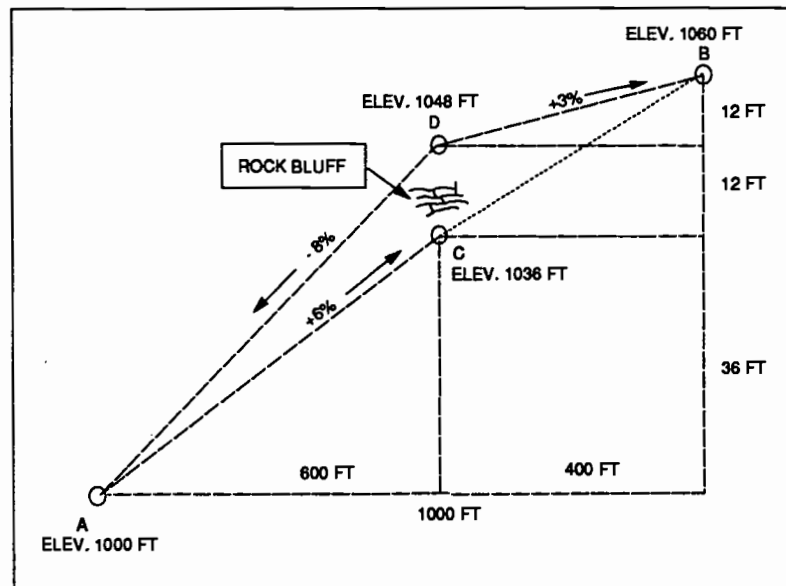


Figure 40. Location on Centerline and at Grade-out.

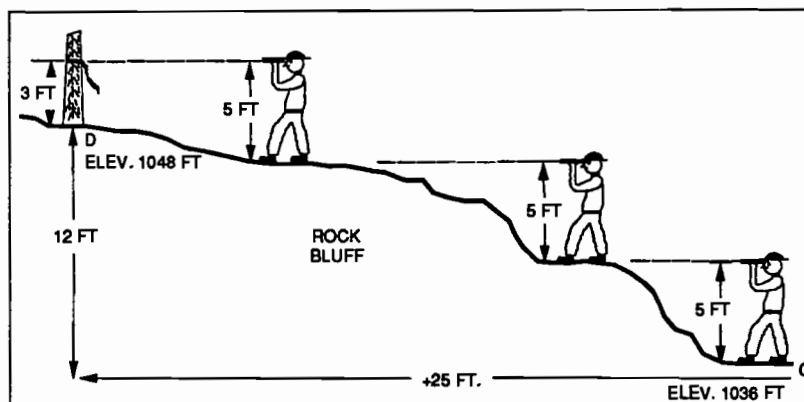
### 5.2.2 Intermediate Location Control Points

While attempting to join two control points, an intermediate control point is often encountered. The problem is usually solved by moving the grade line up or down the slope to an acceptable position, running a new grade line from the new position back to the starting point, and then running a new grade line from the new position to the control point ahead.

For example, in Figure 41 if Control Point A and B are 1000 ft apart, and their elevation difference is 60 ft, it should be possible to join them with a 6% grade (60 divided by 1000 is 0.06 or 6%). After running a 6% grade 600 ft from Control Point A toward Control Point B, a rock bluff is encountered. Additional reconnaissance indicates that the grade line should be moved up the hill 12 ft in elevation. The new position is now 48 ft above Control Point A ( $600 \times .06 = 36 \text{ ft} + 12 \text{ ft}$ ). Since the distance between the control points is still 600 ft, a -8% grade is needed to join them and the new position now 12 ft below Control Point B ( $60 \text{ ft} - 48 \text{ ft} = 12 \text{ ft}$ ) and 400 ft from Control Point B. Thus, the grade needed to intercept Control Point B is +3%.



PROFILE OF INTERMEDIATE CONTROL POINT



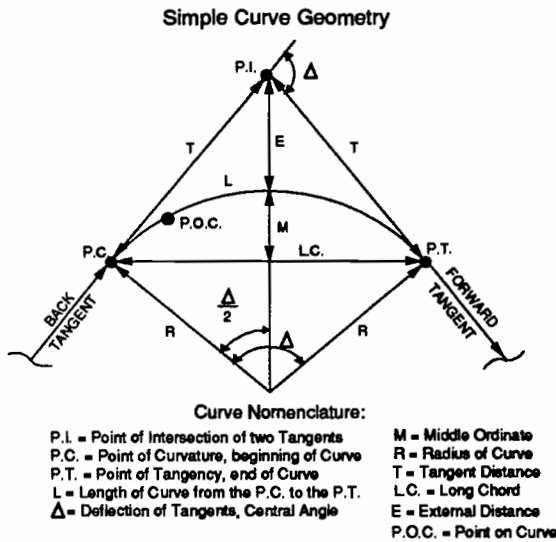
PEGGING UP TO NEW CENTERLINE POSITION

**Figure 41. Grade Line to Establish a Control Point.**

### 5.2.3 Simple Horizontal Curves Location

A close approximate location of a simple horizontal curve can be established rapidly during road location by trial and error. This is accomplished for a given radius curve by turning curve chord deflections with a hand held compass and pacing curve chords (Figure 42). This method is also useful when a curve point of intersection is inaccessible and is being located by one-person.

The information given in Figure 42 is an aid for locating horizontal curves. Curve geometry is defined, curve equations, deflection angles for various radii curves, and curve location procedures are given.

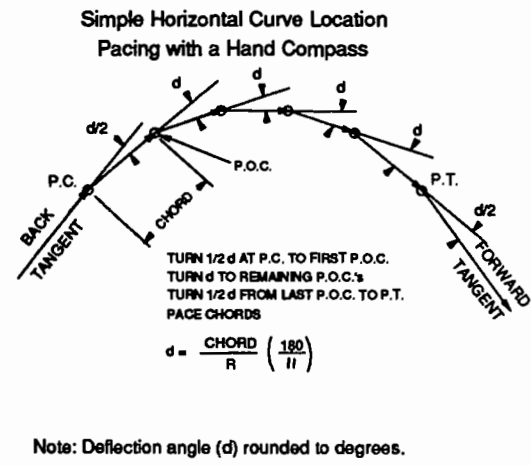


**Curve Equations**

<p>Radius (Arc Definition):</p> $R = \frac{100}{D_a} \left( \frac{180}{\Delta} \right)$ $R = \frac{5729.578}{D_a}$	<p>Middle Ordinate:</p> $M = R \left( 1 - \cos \frac{\Delta}{2} \right)$ $M = E \cos \frac{\Delta}{2}$
<p>Tangent Distance:</p> $T = R \tan \frac{\Delta}{2}$	<p>Length of Curve:</p> $L = \frac{(100)\Delta}{D_a} = (R) (\Delta) (0.0174533)$
<p>External:</p> $E = R \left( \frac{1}{\cos \frac{\Delta}{2}} - 1 \right)$ $E = T \tan \frac{\Delta}{4}$	<p>True Subchord Length:</p> $C_1 = 2R \sin \frac{d}{2}$
	<p>Long Chord:</p> $L.C. = 2R \sin \frac{\Delta}{2}$

**Deflection Angle (d) for Various Radii Circular Curves**

Radius (FT)	25 FT Chords		50 FT Chords	
	1/2d	d	1/2d	d
40	18°	36°	-	-
45	16°	32°	-	-
50	14°	29°	-	-
55	13°	26°	-	-
60	12°	24°	-	-
65	11°	22°	-	-
70	10°	20°	22°	44°
80	9°	18°	20°	41°
90	8°	16°	18°	36°
100	7°	14°	16°	32°
120	6°	12°	14°	29°
140	5°	10°	12°	24°
160	4°	9°	10°	20°
180	4°	8°	9°	18°
200	4°	7°	8°	16°
250	3°	6°	7°	14°
300	2°	5°	6°	11°
400	2°	4°	5°	10°
			4°	7°



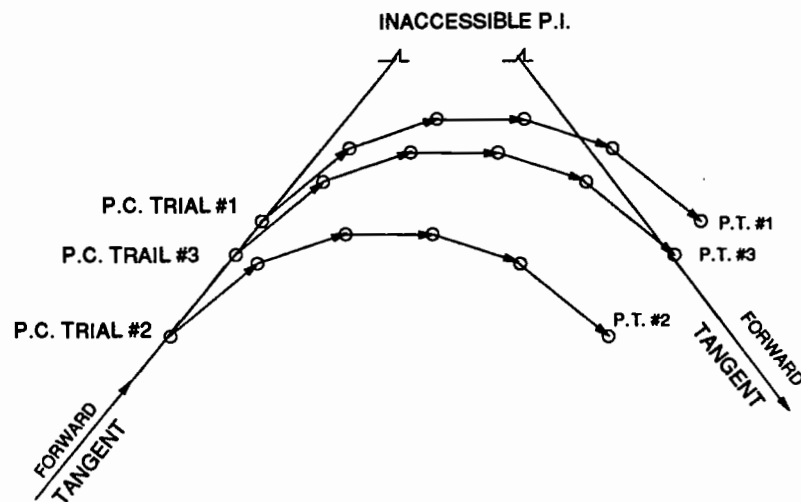
**Figure 42. Horizontal Curve Information for Road Location.**



### 5.2.3.1 Horizontal Curve Location with an Inaccessible Point of Intersection

One person can locate a curve with an inaccessible point of intersection (P.I.) by trial and error between two tangents, Figure 43. An examples of an inaccessible P.I. are two tangent grade lines run into the head of a draw or on a sharp ridge point. The P.I. in the draw would be in the ground and the P.I. on the ridge point would be in the air.

A trial point of curve (P.C.) is established and the curve located toward the forward tangent. If the approximate location of the point of tangent (P.T.) is a significant distance inside or outside the forward tangent, a new trial P.C. is established and the curve relocated, Figure 43. This procedure is repeated until the curve is located close to the forward tangent. The deflection angle ( $\Delta$ ) of an inaccessible P.I. can be determined from the bearings or azimuths of the two tangents.

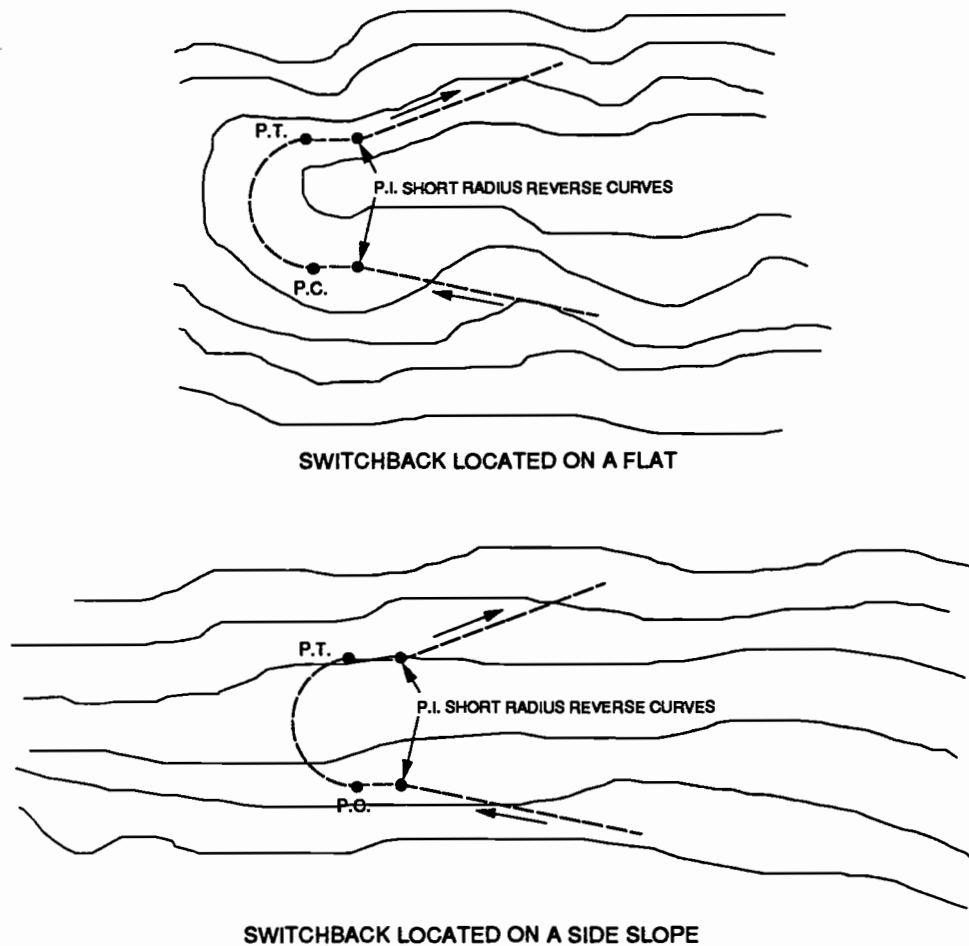


**Figure 43. Curve Location with an Inaccessible P.I.**

### 5.2.4 Horizontal Switchback Curve Location

Location of horizontal switchback curves on steep topography is often performed by trial and error. On a specific location, the switchback curve is adjusted until it properly fits the ground. It is desirable to locate horizontal switchback curves on a flat, however, a switchback can be located on ground with side slopes up to approximately 35 percent or the maximum ground slope that fill material from the switchback cut will stand on (Figure 44).

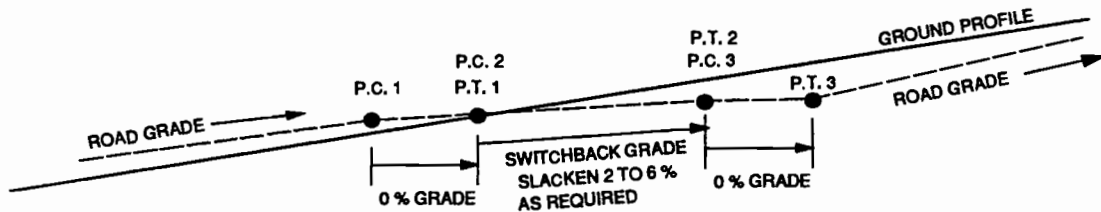
On a minimum radius switchback curve, short radius reverse horizontal curves on each end of a switchback are desirable to force a vehicle to track to the outside of the switchback curve as it enters and leaves the curve (Figure 44). The road locator must use the direct location method to provide the designer with enough latitude to accomplish an acceptable design.



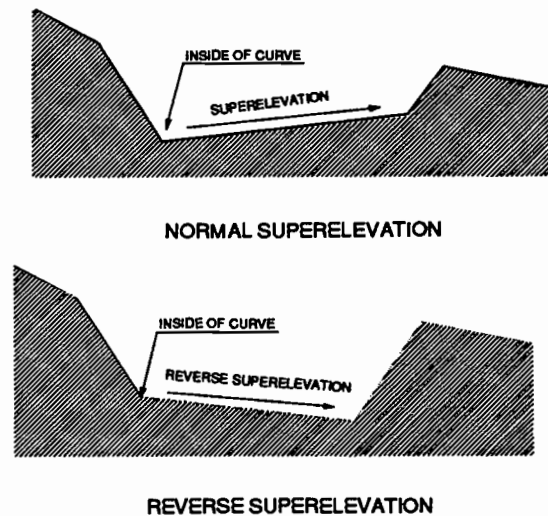
**Figure 44. Switchback Curve Locations.**

When switchback locations are near the maximum allowable grade, the grade through the switchback curve must be reduced due to the compound effects of grade and normal superelevation on a trucks drive train performance. To compensate for this condition, the grade through a switchback is usually slackened 2 to 6% to provide adequate design flexibility (Figure 45). This reduced grade also provides design flexi-

bility for road surface superelevation design. When maximum grades must be located, reverse superelevation and be applied in design to offset the negative effects of grade on vehicle performance (Figure 46)



**Figure 45. Profile Grade Through a Switchback Curve.**



**Figure 46. Superelevation on a Switchback Curve.**

#### 5.2.4.1 Example Switchback Curve Location Procedures

Proper switchback curve location requires the grade line to be set such that the curve can be located on an acceptable grade. If a grade line is run to the beginning of the switchback, and the curve is located using a given radius, and the grade line is then continued at the end of the curve, the gradient in the middle of the switchback will be the same as the ground slope at that point. This condition can yield excessive road grades.

In some cases, the slope of the ground in the switchback curve will be greater than the gradient which is being run. The problem, then, is how to locate the grade line through the switchback curve to provide for an acceptable gradient.

In the example in Figure 47, the switchback location has a ground slope of 15%, and an 80 ft radius curve on a 6% grade is required. If the switchback has a 180 degree deflection angle, the elevation distance on the ground between the beginning and the end of the switchback is 24 ft. The curve long chord for a 80 ft radius curve with an 180 degree deflection angle is;  $(2 \times 80 \text{ ft} \times 0.15 = 24.0 \text{ ft})$ .

If the switchback is to be designed on a 6% grade, there is a 15 ft elevation difference between the beginning and end of the curve on the curve long chord. The difference between 24 ft on the ground and the 15 ft of elevation used in construction must be compensated for. This can be accomplished by cutting 4.5 ft on the uphill side of the switchback and filling 4.5 ft on the downhill side of the switchback. In this example, it is assumed that the cut volume is equal to the fill volume. The compaction factor is 1.0.

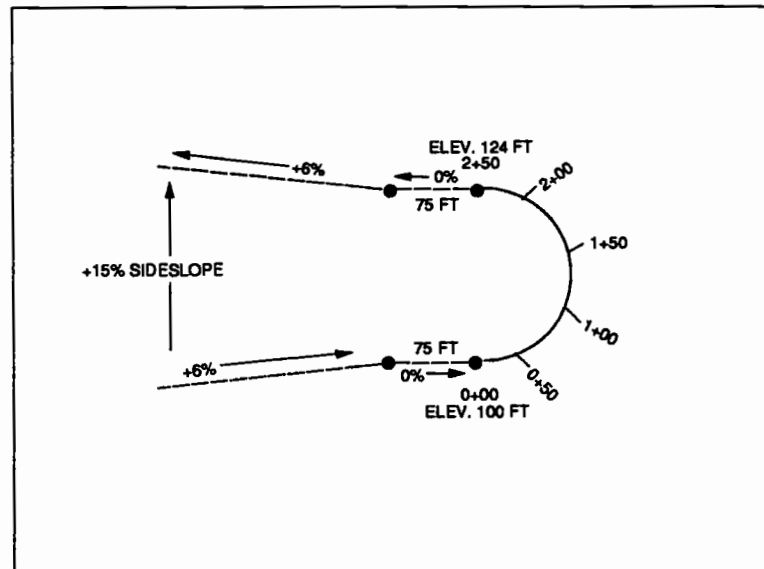
To carry a continuous grade, the cutting and filling must start before the beginning and after the end of the curve. This distance is provided by laying out a 0% grade for 75 ft to the beginning of the curve and 75 ft beyond the end of the curve ( $75 \times 0.06 = 4.5$ ). In this example, the field procedure would be to run the 6% grade to within 75 ft of the beginning of the curve, then run 0% for 75 ft, locating an 80 ft radius with a 180 degree deflection angle, then run 0% for 75 ft beyond the end of the curve, then continue the grade line at 6%.

Curve widening is often required through short radius switchback curves with large curve deflection angles. In the example, the 75 ft distance at 0% grade provides a curve tangent for a short reverse curve, a key hole effect, which decreases vehicle off-tracking through a switchback curve. This is an important factor in providing minimum curve widening through the switchback curve.

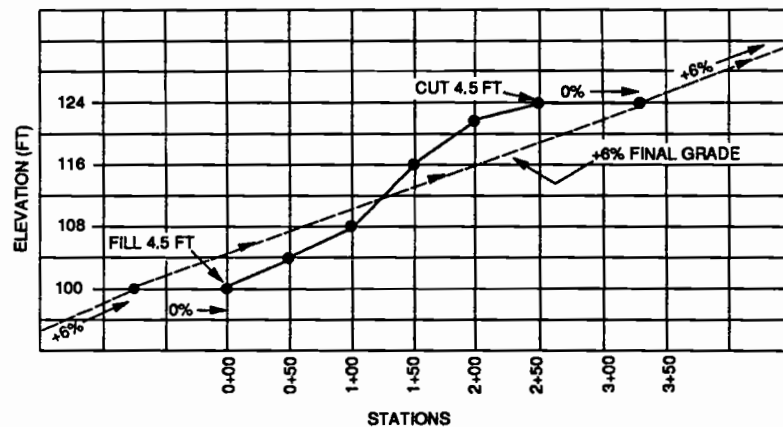
Figure 47 illustrates the proper layout of the 80 foot radius switchback curve on the 15% side slope, providing for construction of a continuous 6% grade through the switchback. The ground profile resulting from this procedure confirms the capability of constructing the desired gradient.

Figure 48 illustrates the result of locating a switchback on a 15% side slope when no attempt is made to compensate for the elevation differences on the ground between the beginning and end of the switchback curve.

Construction of switchbacks on steep ground can require relatively large cuts and fills. For example, the cut and fill required for a 6% grade, an 80 ft radius curve on 20% ground is 8.5 ft, and if the curve was constructed on 30% ground the cut and fill would be 16.5 ft. Often, switchback curve locations are critical control points.

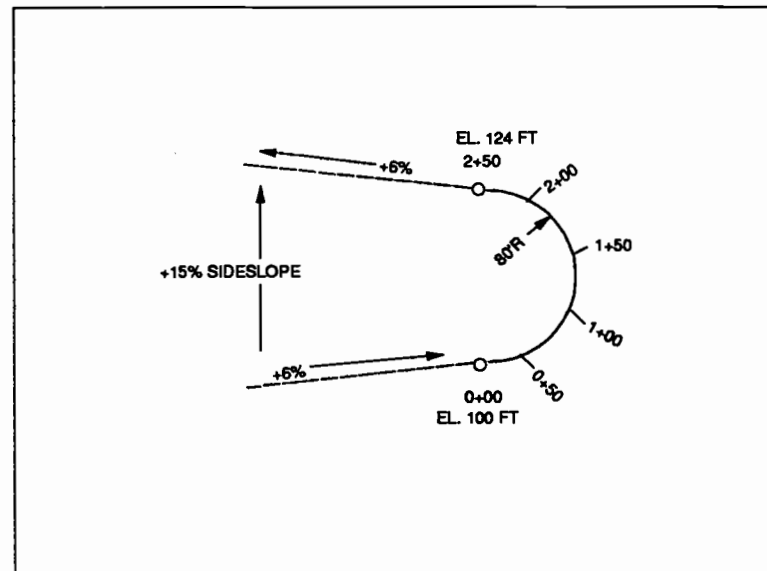


PLAN VIEW OF SWITCHBACK

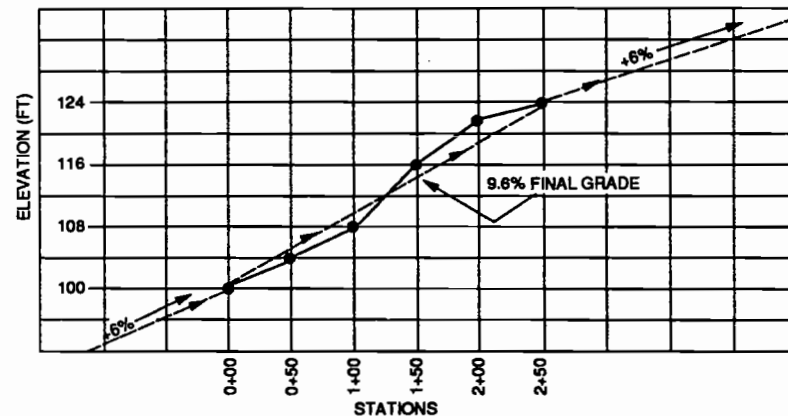


PROFILE OF SWITCHBACK

**Figure 47. Proper Switchback Curve Location.**



PLAN VIEW OF SWITCHBACK



PROFILE OF SWITCHBACK

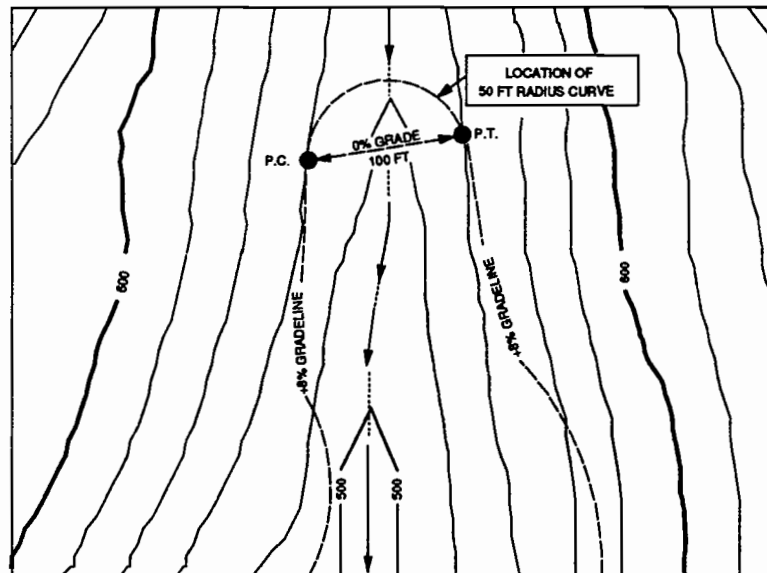
**Figure 48. Improper Switchback Curve Location.**

### 5.2.5 Location of Draw Crossings

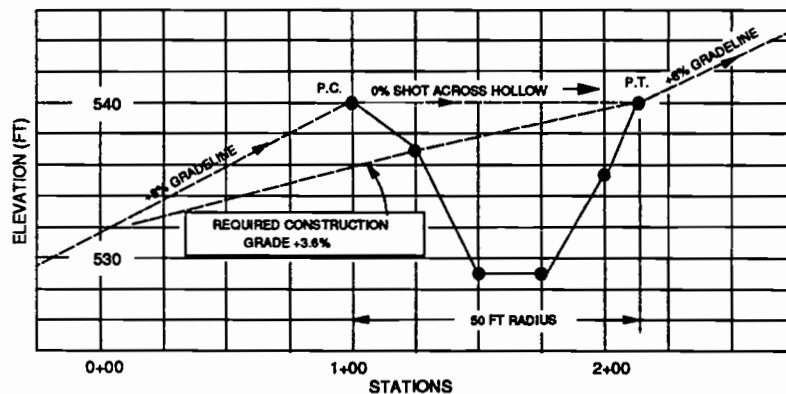
In crossing draws, the grade line must not be continued so far up into the draw that construction of the minimum radius curve will materially increase the finished grade of the road (Figure 49). Where practical, one method used to avoid this problem is to shoot a level grade across the draw at a point where it is twice the radius of the desired horizontal curve.

In the example in Figure 49, the curve radius in the draw is 50 ft, the locater should stop setting grade at a point approximately perpendicular and 100 ft horizontally, twice the curve radius, from the occupied point to the other side of the draw. The point on the other side of the draw is marked on the grade line tangent. This is the trial curve P.T. At that point, a zero grade is shot across the draw, and a flag is set at that established point. Grade at this point is continued out of the draw. This procedure insures that when the curve is constructed, it will fit the ground and the desired grade will not have been exceeded.

Figure 49 illustrates the procedure of shooting at zero percent across the draw and the resulting ground profile. Note that the suggested construction grade is only 3.6% and appears to provide enough cut to fill the draw.



PLAN VIEW OF A GRADE LINE THROUGH A DRAW



PROFILE OF A DRAW WITH A 50 FT RADIUS HORIZONTAL CURVE

### Figure 49. Grade Line Location Through a Draw.

Figure 50 illustrates the consequences of running the grade line too far up into a draw. Joining the grade lines on either side of the draw with a 50 ft radius curve would require construction of a 12% grade, and as the profile illustrates, little or no fill material for construction is provided.

If gaining every possible foot of elevation is imperative, the shot across the draw can be on a grade, however, it should not exceed more than one half of the grade percent run into or out of the draw.



In draws with live streams, the road location should be carried the minimum distance possible up the draw. This will expose the minimum amount of sediment transport from the road prism to the stream channel. This procedure often requires relatively steep grades into and out of the draw. The trade-off of potential sediment transport versus steeper grades must be considered. Horizontal curve location in draws can be accomplished by the trial and error method of curve deflections and chords illustrated in Figure 43, or by direct measurement with a tape as previously described.

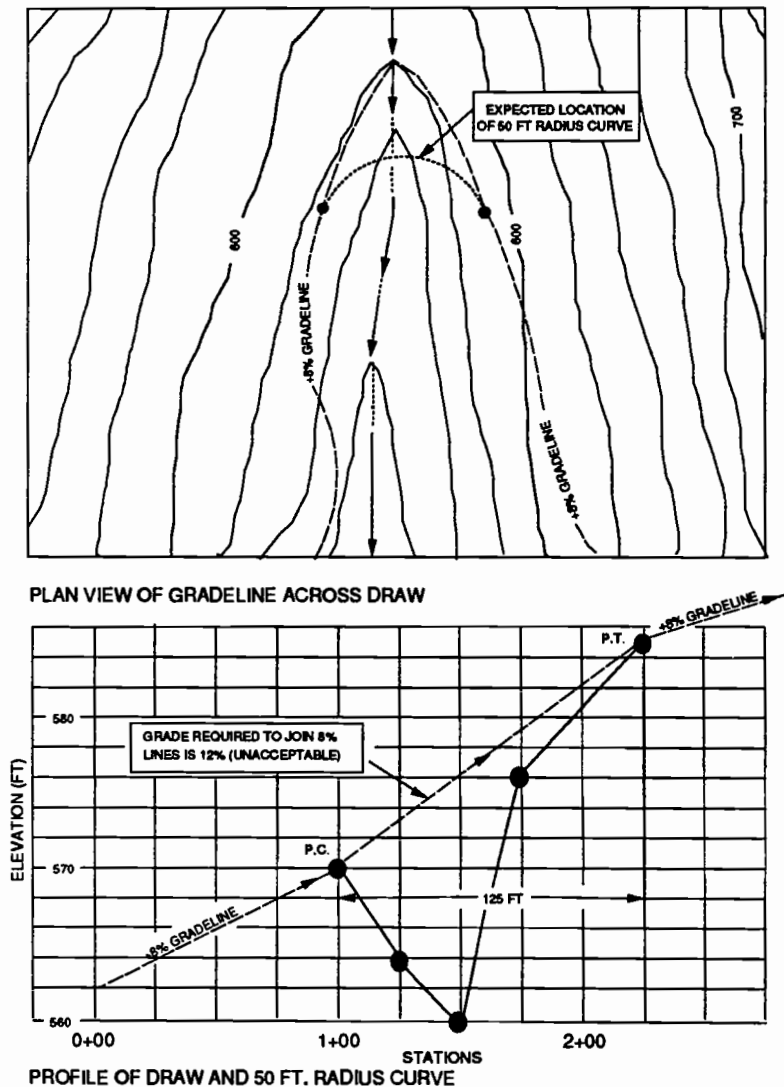
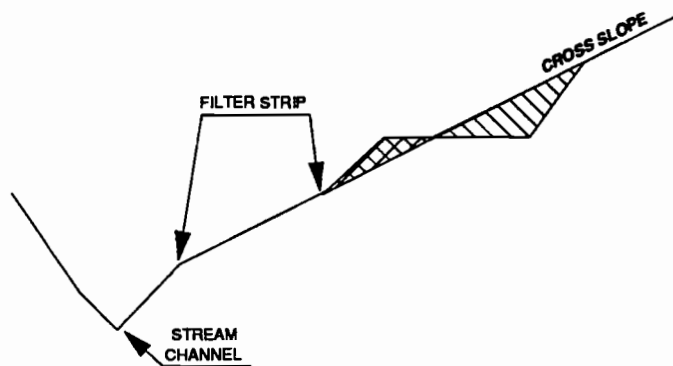


Figure 50. Improper Grade Line Location Through a Draw.

### 5.2.5.1 Location to Reduce Sediment Transport into Streams

To reduce sediment transport from a road into a stream channel, paralleling for prolonged length into and out of stream channels in draws should be avoided when possible. A crossing should be made as soon as possible when entering a draw.

Avoid locations that result in filling into or near the edge of natural stream channels. The toe of fills should be kept as far from stream channels as possible to provide a natural ground surface filter blanket between the fill toe and the stream channel (Figure 51).

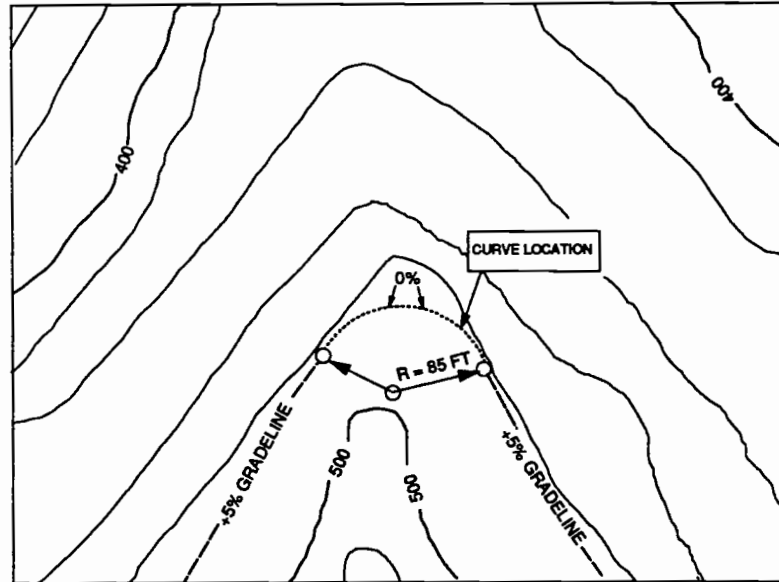


**Figure 51. Road Location Adjacent to a Stream.**

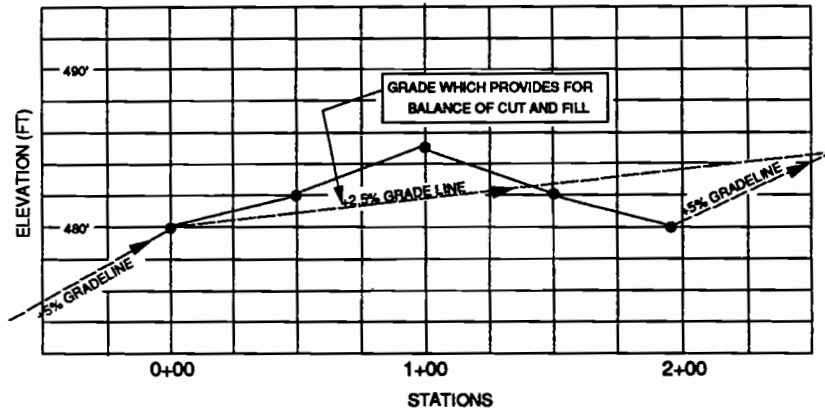
### 5.2.6 Location Around Long Narrow Ridges

The problems of locating grade line around long narrow ridges is similar to the problem of running grade lines too far up into a draw. If a continuous grade is run around the nose of the ridge, excessive curvature may result. If the radius of the horizontal curve is increased during construction, the gradient around the curve will be increased. To avoid either situation, a grade of zero percent should be run from the beginning of the curve to the end of the curve. The grade line can be continued from the end of the curve. This procedure allows for design and construction of the located horizontal curve radius and provides an acceptable grade through the curve.

Figure 52 illustrates the procedure for running around the nose on a zero percent grade and the resulting ground profile. Note that the curve can be constructed on a 2.5% grade and allows for a balance of earthwork.



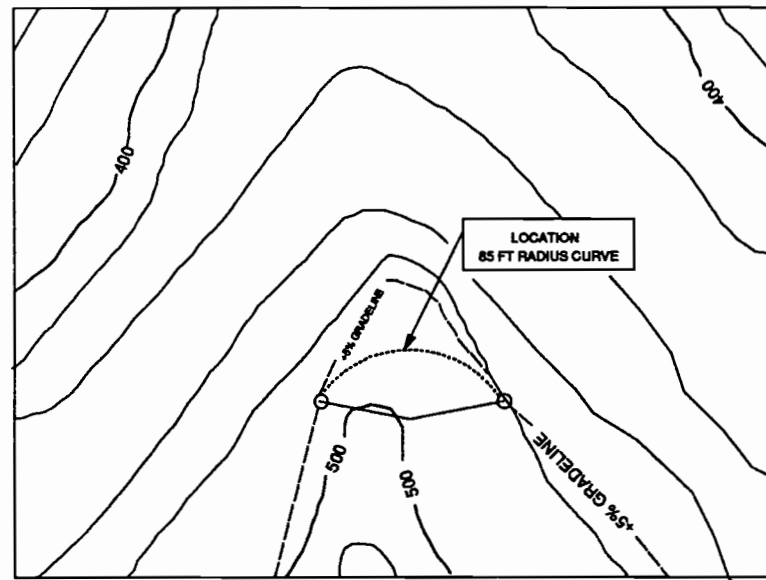
PLAN VIEW OF GRADELINE AND RIDGE



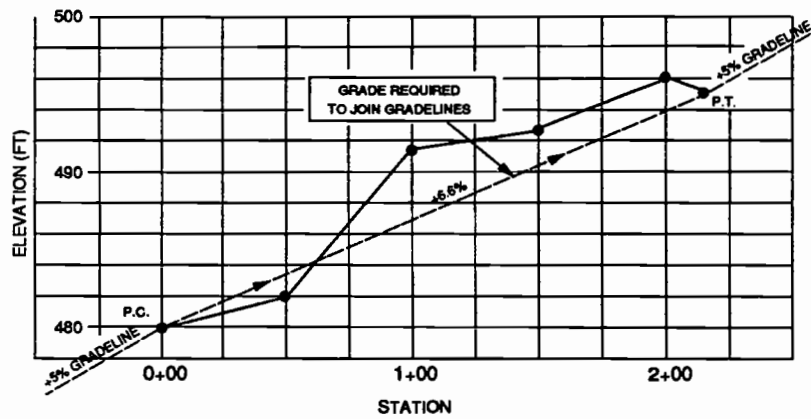
PROFILE OF A RIDGE AND WITH AN 85 FT. RADIUS CURVE

**Figure 52. Proper Grade Line Location Around a Narrow Ridge.**

Figure 53 illustrates the result of running a continuous grade line around the nose of a narrow ridge and constructing a larger radius curve to avoid excessive curvature. Note that the gradient is increased, and the curve would be in a through cut approximately the entire length of the curve.



PLAN VIEW OF GRADELINE ON RIDGE POINT



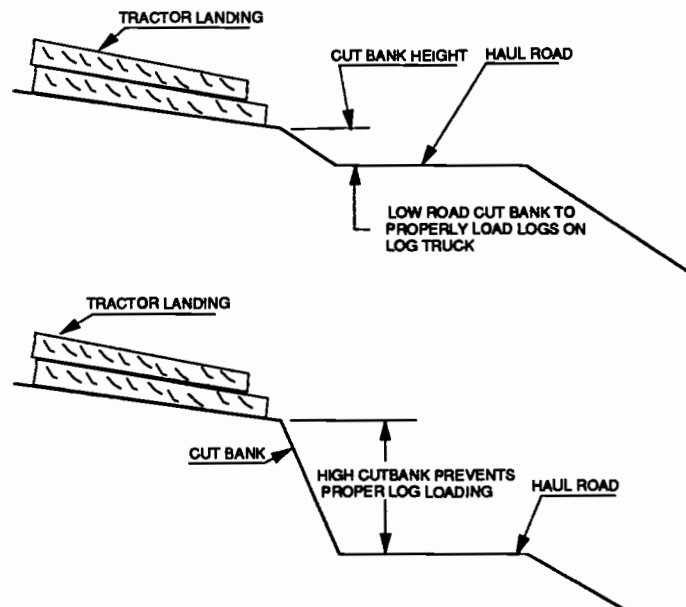
PROFILE ON A RIDGE WITH AN 85 FT RADIUS CURVE

**Figure 53. Improper Grade Line Location Around a Ridge.**

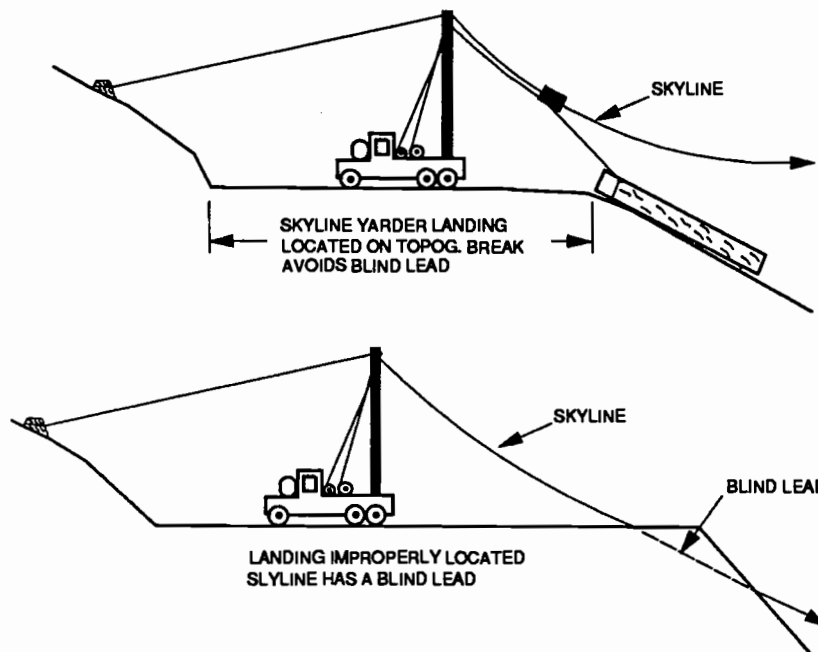
### 5.2.7 Logging Landings

Tractor logging landings should be located in areas with gentle back slopes and low road cut banks, to facilitate log truck loading (Figure 54). To the extent possible, roads should be located on topographic breaks for skyline logging to prevent blind lead situations. A blind lead occurs when skyline logging cables deflect into the skyline ground profile (Figure 55). Road segments to be used as continuous landings

should have grades of 6% or less to provide for leveling of stationary logging equipment. When possible, road turnouts should be located to provide for log landings on the turnouts. This location minimizes excavation quantities and costs.



**Figure 54. Tractor or Skidder Log Landing Location.**



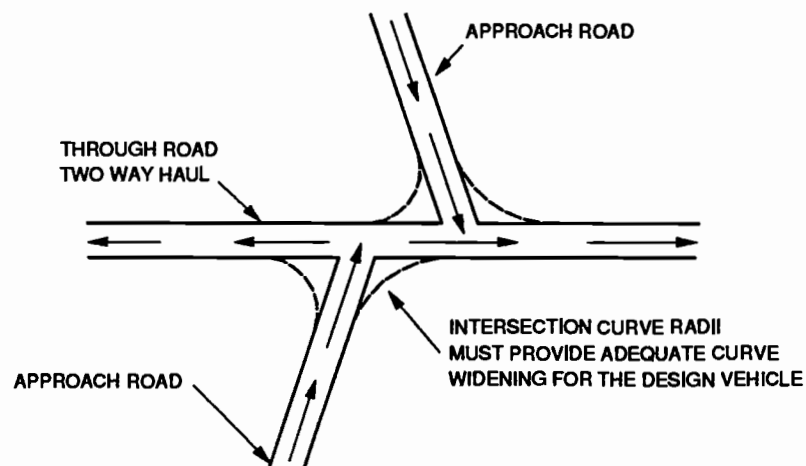
**Figure 55. Skyline Logging Landing Location.**

### 5.2.8 Road Intersections

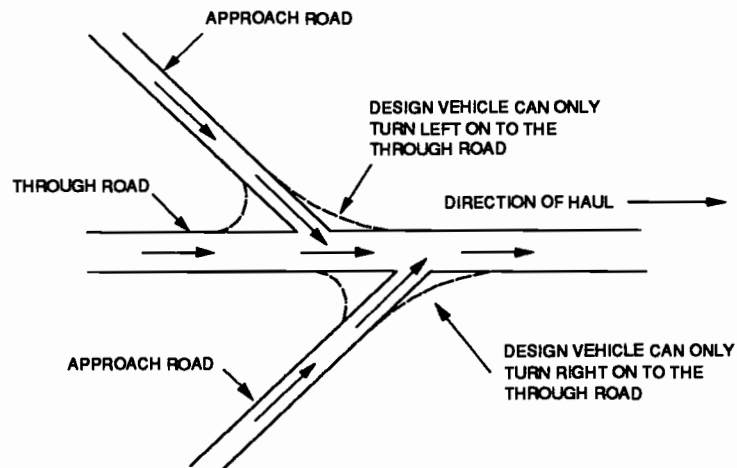
Often, on difficult terrain, intersections are directly located to assure adequate design flexibility. When locating one-lane resource development road intersections to facilitate log hauling, the direction of haul must be known to assure that trucks can negotiate the turn.

The angle of an intersecting approach road should not be less than approximately 60 degrees when resource development traffic must turn on and off an approach road in two directions at through road intersection (Figure 56). Road intersection angles can be less than 60 degrees when the direction of haul is one way off an approach road onto a through road (Figure 57).

When possible, the grade of an approach road should not exceed 6 percent. Grade of intersecting roads in an intersection should be the same until adequate horizontal separation is achieved. On approach roads with fill sections, the common intersection grade must be carried a sufficient distance to preclude a portion of the vertical curve being in the intersection.



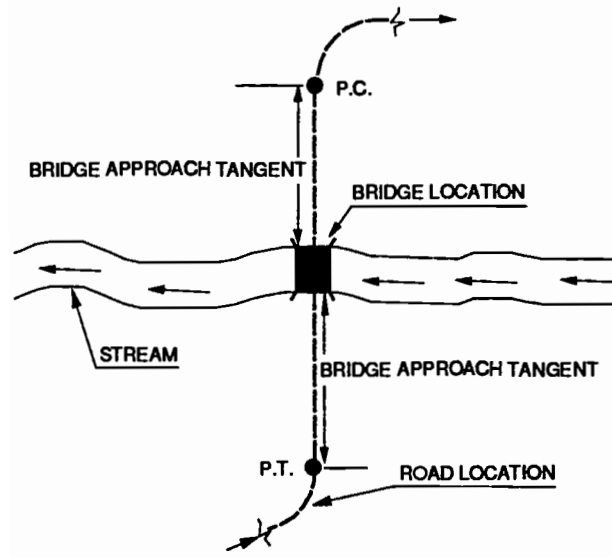
**Figure 56. Intersection Location for Two-way Log Haul.**



**Figure 57. Intersection Location for One-way Log Haul.**

### 5.2.9 Stream Crossing Bridge Sites

Ideal bridge approach alignments are perpendicular to a stream crossing and provide adequate sight distance. If horizontal curves are required on a one-lane timber bridge approach, adequate horizontal tangent distance from the curve point of tangent (P.T.) must be provided to prevent vehicle off-tracking onto the bridge deck (Figure 58). Bridges that are skewed, or require horizontal curves and grade change on a bridge superstructure, cost more to construct than a structure located perpendicular to a stream channel. When possible, the crossing site should have solid bridge abutment foundations. Difficult stream crossing sites are often directly located to provide maximum design flexibility.



**Figure 58. Stream Crossing Location.**



## **6 CONCLUSION**

The development and design of low volume recreation and resource development roads diverges from the accepted criteria for high volume highways, traffic capacity, and flow. There are many factors affecting the design of low volume recreation and resource development roads that are not considered in traditional highway design.

High volume transportation facilities often are preliminarily located and designed to evaluate traffic flow and minimize local impacts. The operating costs, maintenance costs, environmental considerations, safety, capital costs, often do not vary substantially between alternatives. Low volume special purpose roads require consideration of all these factors on each facility in order to meet land management objectives.

Resource development roads may be designed for a single resource development function, such as logging, or be required to accommodate mixed vehicle traffic, for example, log trucks and recreation vehicles. Certain recreation and resource development roads may or may not require a design accommodating the requirements of the National Highway Safety Act. All high volume transportation facilities must meet the requirements of this act.

A sound process for determining special purpose road design criteria, elements, and standards has been presented. This data can be used in the design of low volume recreation and resource development roads that meet resource management objectives, minimize costs, and mitigate environmental concerns.

## **7 RECOMMENDATIONS**

There are many differences between the development and design of high volume transportation facilities and the development of low volume, special purpose recreation and resource development roads. In this document, these differences have been described in detail. It is recommended that road designers, with little experience in the design of resource development roads, use this document as a guide when required to design low volume recreation and resource development roads.

There is a lack of sufficient information for the design of low volume special purpose roads in the AASHTO Green Book (1). It is recommended that the pertinent information presented in this document be included in the next revision of the AASHTO Green Book (1).

## 8 BIBLIOGRAPHY

1. American Association of State Highway and Transportation Officials, "A Policy on Geometric Design of Highways and Streets," Washington, D.C., 1990.
2. U.S.D.A. Forest Service, "Forest Service Handbook No. 7700.56 - Road Pre-construction Handbook," 1987.
3. Brewster, H., R. Rice, "Tires: Stability and Control," SAE Transactions, Vol. 92, Paper 830661, 1983.
4. Campbell, C., "The Sports Car: Its Design and Performance," Robert Bentley, Inc., Cambridge, Mass, 1978.
5. Shadler, S., L Emery, and H. Brewer, "Vehicle Breaking, Stability and Control," SAE Transactions, Vol. 92, paper 830562, 1983.
6. Wong, J., "Theory of Ground Vehicles," John Wiley & Sons, New York, 1978.
7. Mannering, F., W. Kilareski, "Principles of Highway Engineering and Traffic Analysis," John Wiley and Sons, New York, New York, 1009.
8. Kramer, B., "Vehicle Tracking Simulation In Low Volume Road Design," Fourth International Conference on Low-Volume Roads. Transportation Research Board, National Research Council, Washington, D.C., TRR 1106, Volume 2, pp 119-122, 1987.
9. Kramer, B., "Vehicle Tracking Simulation Techniques for Low Speed Forest Roads in the Pacific Northwest," paper PNR-82-508, American Society of Agricultural Engineers, 1982.
10. Erkert, T., "Computer Simulation of Offtracking of Truck and Trailer Combinations Using Forest Roads," Masters of Science thesis, Oregon State University, Corvallis, Oregon, 1989.
11. Alexander, G.J., And Junenfeld, H., "Positive Guidance in Traffic Control", Washington D.C., U.S. Department of Transportation, Federal Highway Department, 1975.
12. Nielsen, R., "A Procedure for Analyzing Double-Lane Versus Single Lane Roads," Masters of Science thesis, Oregon State University, Corvallis, Oregon, 1987.
13. Transportation Research Board, "Special Report No. 209", Transportation Research Board, National Research Council, Washington, D.C., 1985
14. Kavanagh, B., "Surveying With Construction Applications," Second Edition, Prentice-Hall, Inc., Englewood Cliffs, New Jersey, 1992.
15. Highway Design Manual, Oregon State Department of Transportation, Salem, Oregon, 1988.
16. Forest Practices Act Code, Draft, Oregon Occupational Safety and Health Division, Salem, Oregon, April 30, 1991.

17. WAC Chapter 296-54, Division of Labor and Industry, Olympia, Washington, 1981.
18. Unpublished Design Elements and Standards, Mapleton Ranger District, Siuslaw National Forest, Corvallis, Oregon, 1990.
19. Anderson, P., M. Pyles, and J. Sessions, "Considerations in the Operation of Highway Log Trucks on Steep Low-Volume Roads," Fourth International Conference on Low-Volume Roads. Transportation Research Board, National Research Council, Washington, D.C., TRR 1106, Volume 2, pp 104-111, 1987.
20. Kramer, B., Unpublished road design notes, Forest Engineering Department, Oregon State University, Corvallis, Oregon, 1991.
21. Oregon Department of Transportation, Highway Division, "Hydraulic Manual," Salem, Oregon, 1990.
22. American Iron and Steel Institute, "Handbook of Steel Drainage and Highway Construction Products," Washington, D.C., 1983.

## Appendix

## **AREA TRANSPORTATION EXAMPLE**

### **Area Transportation Plan Development**

Development of example road management objectives, design elements, and standards are determined for the Cactus Mountain project planning area illustrated in Section 4, Figure 36. Resource management objectives determined for the planning area are timber management and winter recreation. Road No. 1200 is reconstructed now. Road No. 1250 will be constructed now, for the first timber sale, and Road No. 1251 will be constructed at year 7 for the second timber sale.

### **Road Management Development**

There are two primary mitigating environmental concerns related to road development within the Cactus Mountain project planning area. The erosion potential of sensitive soils on roads No. 1250 and No. 1251 are key design and maintenance concerns. Soils in slopes on route locations are stable. The entire area is within a state large game management area. Timber harvest activities are expected to enhance large game feeding forage. Due to expected concentrations of large game during the big game hunting season, road closures must be implemented.

Visual resource management must be considered for a background view from a viewing point in another planning area. Minimum road cuts and fills will accomplish the visual resource objective.

Road No. 1200 will be an all-weather facility providing access for timber management operations in the summer and access for winter recreation on Road No. 1250. A winter recreation vehicle parking area is required adjacent to Road No. 1200 at the junction of Road No. 1250. Road No. 1250 will be used for winter cross country skiing recreation activities. Road No. 1251 will be closed at the conclusion of timber harvest operations. Roads No. 1250 and No. 1251 will be closed to public vehicle access during the big game hunting season.

As determined from area resource management objectives and the area harvest plan, the design vehicle is the automobile, and the critical vehicle is a truck tractor with a 36 foot trailer. On roads No. 1250 and 1251, the design and critical vehicle are the log truck and truck tractor trailers.

Developed from resource management objectives and traffic analysis estimates of total traffic volume by type, average daily traffic (ADT), design speed and traffic service levels are determined. For the Cactus Mountain project planning area, this information is summarized in Table 28.

**Table 28. Traffic Analysis and Traffic Service Levels.**

Road No.	Trucks Vol.	Pickup Trucks Vol.	Autos Vol.	ADT	Design Speed (mph)	TSL
20 Years						
1200	9000	6000	13000	40	20	B
1250	5000	2000	-	25	15	C
1251	4000	2000	-	30	10	C

**Note:** Traffic service level (TSL).

The necessary data have been developed by the project interdisciplinary team to establish road management objectives and the necessary design elements for the transportation network. This data provides the required information to develop design standards and elements that meet resource management and road management objectives.

#### Road Design Elements and Standards

The following is a summary of the required road elements, and standards for the design of the roads in the Cactus Mountain project planning area transportation network. These may be further refined during the road design process.

**Road 1200**

## Design elements:

- Design vehicle - automobile.
- Critical vehicle - truck tractor with a 36 ft trailer.
- Design speed - 20 mph.
- No. Lanes - one, two-directional.
- Drainage ditches

## Road geometric standards:

- Turnouts - intervisible, 10 ft wide, 75 ft length, and 50 ft tapers at each end.
- Maximum turnout spacing - 1,000 ft.
- Minimum horizontal curve radius - 100 ft.
- Maximum grade -  $\pm 10\%$ .
- Minimum vertical curve - 200 ft.

## Cross-section standards:

- Surface traveled-way width - 14.0 ft.
- Surface templet - crowned 5%.
- Shoulder - 2.0 ft each side of road.
- Ditch - foreslope 2:1, depth 1.0 ft., culvert catch basins 3 ft wide, 3 ft deep.
- Cut slope - 1:1 common material, 3/4:1 rippable rock.
- Fill slope - 1.5:1 common material, 1.33:1 rippable rock.

## Road surfacing standards:

- Surface course - 3/4 in minus dense graded aggregate, 6.0 in depth, 2:1 slope.
- Base course - 1 in minus open graded aggregate 8.0 in depth, 2:1 slope.

## Other required standards:

- Culvert spacing - maximum 300 ft.
- Parking facility - design for 25 automobiles.



**Road 1250**

## Design elements:

Critical vehicle - truck tractor with a 36 ft trailer.

Design speed - 15 mph.

No. Lanes - one, two-directional.

## Road geometry standards:

Turnouts - intervisible, 10 ft wide, 75 ft tapers each end.

Maximum turnout spacing - 1,000 ft.

Minimum horizontal curve radius - 60 ft.

Maximum grade -  $\pm 10\%$ .

Minimum vertical curve - 100 ft.

## Cross-section standards:

Surface traveled-way width - 12.0 ft.

Surface templet - in slope or out slope 5%.

Shoulder - 2.0 ft outside and 1.0 ft inside.

Ditch - fore slope 2:1, depth 1.0 ft, culvert catch basins  
3 ft wide, 3 ft deep.

Cut slope - 1:1 common material, 3/4:1 rippable rock.

Fill slope - 1.5:1 common material, 1.33:1 rippable rock.

## Road surfacing standards:

Surface course - 2 in Minus dense graded aggregate, 8.0 in depth,  
2:1 slope.

## Road drainage standards:

Culvert spacing - maximum 200 ft.

**Road 1251**

## Design elements:

Design vehicle - stinger type log truck.

Critical vehicle - truck tractor with a 36 ft trailer.

Design speed - 10 mph.

No. Lanes - one, two-directional.

## Road geometry standards:

Turn outs - intervisible, 10 ft surface width, 75 ft tapers each end.

Maximum turnout spacing - 1,000 ft.

Minimum horizontal curve radius - 60 ft.

Maximum grade -  $\pm 20\%$ .

Minimum vertical curve - 100 ft.

## Cross-section standards:

Surface traveled-way width - 12.0 ft.

Surface templet - out-slope 5%.

Shoulder - 2.0 ft each side of road.

Cut slope - 1:1 common material, 3/4:1 rippable rock, 1/2:1 solid rock.

Fill slope - 1.33:1 common material, 1.25:1 ripped rock.

## Road surface standards:

Surface course - 2 in minus dense graded aggregate, 8.0 in depth, 2:1 slope.

## Road drainage standards:

Drain dips- minimum transition 100 ft. maximum fill slope height at bottom of dip 6 ft.

