

AN ABSTRACT OF THE THESIS OF

Takayuki Hirai for the degree of Master of Science
in Fisheries presented on September 8, 1987

Title: A Model for Understanding the Influence of Selective
and Nonselective Harvest on Fish Populations

Abstract approved:

Redacted for Privacy

William J. Liss

To understand the influence of selective harvesting on the adaptive capacity of fish populations in changing environments, a computer simulation model was developed. In the model, hypothetical populations were composed of five different life histories, which were genetically determined. Each life history type had its own rate of survival and reproduction that varied with changing environment and population density. In nonselective harvesting, life history types were equally vulnerable to harvest. In selective harvesting some life history types, were more intensively harvested than others.

Population life history composition changed continuously in response to both changing environmental conditions and harvesting. Changes in life history composition were closely related to changes in numerical population performances such as density and yield.

In general, selective harvesting of the simulated

populations reduced mean and terminal abundance, total catch, and life history diversity. Nonselective harvesting tended to eliminate individuals evenly from the life history distribution so that the life history diversity was not greatly influenced. Selective harvesting tended to severely reduce or eliminate the life history types that were more intensively harvested. This generally resulted in extreme reduction of life history diversity. Variation in abundance, as measured by the absolute value of the residuals, was consistently larger in selectively harvested populations. Increased variation was probably related to reduction in life history diversity. Perhaps the most potentially alarming impact was the dramatic increase in incidences of extinction of selectively harvested populations at the highest exploitation rate. High selective harvest rate led to severe reduction in life history diversity which diminished the population's ability to persist in a changing environment. Furthermore, the extreme reduction of life history diversity made it difficult for populations that were able to persist to recover in abundance after termination of harvest.

It is important to note, however, that the above conclusions are general outcomes based on 20 different environmental regimes. The results from a few individual regimes were not in accordance with some of the general outcomes, illustrating simply that particular results are highly contingent on the particular environmental pattern.

A Model for Understanding the Influence
of Selective and Nonselective Harvest on
Fish Populations

by

Takayuki Hirai

A THESIS

submitted to

Oregon State University

in partial fulfillment of
the requirements of the
degree of

Master of Science

Completed September 8, 1987

Commencement June 1988

APPROVED:

Redacted for Privacy

Associate Professor of Fisheries in charge of major

Redacted for Privacy

Head of Department of Fisheries and Wildlife

Redacted for Privacy

Dean of Graduate school

Date thesis is presented _____ 8 September 1987

Typed by Chie Hirai for _____ Takayuki Hirai

ACKNOWLEDGMENTS

I would like to express my appreciation to my major professor, Dr. William J. Liss, for providing me with the opportunity to pursue this advanced degree, and for his proper guidance, encouragement, and friendship throughout this project. Dr. Charles E. Warren deserves special thanks for his role in the development of the theory and the model.

I wish to thank Dr. David R. Thomas for his advice regarding statistical problems. In addition to these committee members, Dr. Ching Y. Hu also is thanked for his time and interest.

The staff and students at the Oak Creek Laboratory of Biology have my appreciation for their help and friendship. Mary Jo Wevers reviewed and edited drafts of this thesis.

My special appreciation is extended to my wife Chie for her constant support and encouragement throughout this work.

TABLE OF CONTENTS

INTRODUCTION	1
THEORETICAL FRAMEWORK	6
MODEL DEVELOPMENT	14
Environmental Conditions	14
Age-Specific Life Table : m_x and s_x schedules	15
Variability in the Life Table	16
Density Dependent Factors	19
Genetic Structure of the Hypothetical Population	19
Mating Mechanism : Random Mating	22
Fishing Effort	26
Population Projection	27
Analysis	32
Extinction	33
Short Term Variation	33
Diversity Index	33
Mean Density, Terminal Density and Catch	34
RESULTS AND INTERPRETATION	37
Dynamics of Unharvested Stock	37
Effects of Increased Harvesting Effort	42
Effects of Selective and Nonselective Harvesting	42
Population Recovery	52
DISCUSSION	58
LITERATURE CITED	67

LIST OF FIGURES

<u>Figure</u>		<u>Page</u>
1	Hierarchical structure of a species.	8
2	Potential adaptive capacities and developmental states of species, population or stocks, and individual life history types in different environments.	9
3	The diagrammatic illustration of relationship between conceptual framework, theory and model.	11
4	General forms of l_x and m_x curves of a life history type.	17
5	Density dependent relationships for mortality and reproduction.	20
6	Diagrammatic illustration of the life history mechanism of the model.	30
7	Locally weighted regression analysis (Smoothed line)	35
8	Relationships between environmental variation, population life history diversity and population abundance under no harvesting conditions (environmental regime 14).	39
9	Relationships between environmental variation, population life history diversity and population abundance under nonselective harvesting and selective harvesting conditions with harvesting mortality, $F = 0.5$ (environmental regime 14).	46
10	Population recovery following nonselective and selective harvesting ($F=0.5$) for 100 years in environmental regime 14.	55

LIST OF TABLES

<u>Table</u>		<u>Page</u>
1	Random mating mechanism.	25
2	Summary of population performance under 20 different environmental regimes with no harvesting effort.	38
3	Summary of influences of selective and nonselective harvest at fishing mortality of 0.3.	43
4	Summary of influences of selective and nonselective harvest at fishing mortality of 0.5.	44
5	Summary of influences of selective and nonselective harvest at fishing mortality of 0.65.	45
6	Summary of population recovery following nonselective and selective harvesting ($F=0.5$) for 100 years in three regimes 1, 11 and 14.	54

A MODEL FOR UNDERSTANDING THE INFLUENCE OF SELECTIVE AND NONSELECTIVE HARVEST ON FISH POPULATIONS

INTRODUCTION

In the study of the distribution and abundance of fish populations and their responses to harvesting, mathematical models have been developed and used in management to attempt to achieve resource optimization and stabilization. This is most apparent in the concept of maximum sustainable yield (Larkin 1977), which has become a management objective for very many commercially harvested fish stocks. Fisheries modelling has its roots in a mechanistic world view (Pepper 1942) and consequently suffers from several shortcomings. Fisheries models have tended to uncouple the population from its environment (eg. Ricker 1954, Schaeffer 1955, Beverton and Holt 1957, Ricker 1975). Furthermore, these models have tended to view the population as having little organization other than age or size structure. The evolutionary consequences of harvesting including alteration of adaptive capacity through loss of life history diversity are rarely considered. These mathematical models have been uncertain guides to fishery management. Often overfishing, as Andrewartha and Birch (1984) suggest, might be a consequence of poor management based on poor models.

Some fisheries biologists have been concerned that harvesting and other human activities may affect not only

the numerical properties of stocks such as density and age structure but may also alter the capacity of stocks to adapt to their environments (Murphy 1968, Schaeffer and Elson 1975, Warren and Liss 1980). Murphy (1968) argued that long life and multiple reproductions per lifetime adapted herring-like fishes to environments in which juvenile mortality was high and variable. Murphy suggested that intensive harvest of California sardine significantly reduced average life span and number of reproductions per lifetime, stripping away the mechanism the population had evolved to persist in its environment. He contends that this contributed to the collapse of the sardine fishery in the early 1950's. Egg size, which may increase with increasing fish size, may be an important survival characteristic for Klamath River chinook. Commercial fisheries have selectively harvested larger, older fish. Consequently, the average size and age of spawners has been significantly reduced and future viability of chinook in its natural habitat seems uncertain (Hankin and McKelvey 1985). Ricker (1981) has argued that commercial fisheries selectively harvest faster-growing and later maturing fish and that this has resulted in reduction in age at maturity and average size of Canadian Pacific salmon stocks. However, he did not speculate on the adaptive significance of these changes. Schaeffer and Elson (1975) suggest that large size achieved through delayed maturity enables certain

populations of Atlantic salmon to make their spawning run up long, turbulent rivers of Northeast Canada. Commercial gill net fisheries at the mouths of these rivers selectively harvested the larger fish thus removing from the populations the best adapted individuals.

There may be considerable variation in life history characteristics between stocks of fish of a given species. Iles and Sinclair (1982) have identified several dozen stocks of Atlantic herring that differ in spawning season and duration of spawning. Spangler et al. (1977) discussed the discreteness of local stocks of percids in the Great Lakes. They suggest that human activities including harvest have been responsible for the loss of local populations of percids and are concerned about the implications of this to percid persistence in the Great Lakes. Life history variation between stocks of Pacific salmon and steelhead has been well-documented (Ricker 1972). This variation is generally attributed to adaptation to differences in the habitats of the stocks (eg. Beachan and Murphy 1986). Larkin (1977) argued that increased ocean harvesting effort, in quest of greater cumulative yields can result in loss of local stock diversity through elimination of populations that may be highly vulnerable to harvest. The adaptive basis for some aspects of life history variation between stocks of Atlantic salmon was considered by Schaeffer and Elson (1975).

While there has been considerable interest in variation between stocks, there has been relatively little discussion of life history variation within fish stocks and its adaptive significance. In ecological theory, life history variation within natural populations is thought to be an adaptation to spatial and temporal variation in the environment (den Boer 1968, Levins 1968, Schaeffer 1979, Andrewartha and Birch 1984). Thompson (1962) suggested that within-stock variation in Pacific salmon had an adaptive basis. Holtby and Healey (1986) considered why there was such a wide variation in size at maturity in Carnation Creek coho salmon. They argued that different sized adult coho were adapted to spawn in different kinds of microhabitats within the stream. Reiners (1971) identified several different freshwater life histories in Sixes River chinook salmon. If life history variation within populations has an adaptive basis, selective harvest, habitat destruction, or any other human activity that leads to a loss of life history diversity may have serious consequences for population persistence.

The goal of this research is to advance understanding of the influence of harvesting on the adaptive capacities of fish populations in a changing environment. This was approached through development of a computer model to examine theoretically the influence of selective and nonselective harvesting of life history types on life

history diversity, abundance, yield and persistence of fish populations in changing environments.

THEORETICAL FRAMEWORK

World views are ways of symbolizing, articulating and providing perspective on total experience (Pepper 1942, Warren and Liss 1980). Fisheries modeling has been deeply rooted in a mechanistic the world view. Generalizations characterizing this view are : 1) a system can be analyzed into discrete elements; 2) the behavior of a system is determined by its elements independent of its environment or field of location; and 3) change in the system, its environment and its elements are only quantitative but not qualitative.

A world view that is alternative to mechanism is contextualism. Based upon the concept, 1) everything is interrelated among a system, its context and its elements, thus the behavior of a system is determined jointly by its element and its context; 2) the interaction of the elements and context will lead to qualitative change in each (Warren and Liss 1980). This research was approached from a more contextualistic perspective.

Populations or stocks are continuously adapting systems. Their adaptive capacity is their potential for both life history and evolutionary adaptation (Warren and Liss 1980). A stock with a given adaptive capacity will evolve in different ways in different environment (Fig. 2).

The adaptive capacity of a stock is entailed in its organization which involves the incorporation of

interrelated and interpenetrating life history types (Fig. 1). We assume that the different types composing the stock are adapted to different habitats or environmental conditions. Stock evolution can be viewed as change not only in the genetic organization of a stock, but also change in its organization of life history types, this entailing the disappearance and reappearance of types as well as change in their abundances.

Each life history type in a stock has its own genetically determined potential capacity (Fig. 3A) or life history capacity. The life history capacity is the potential to develop different life history patterns in different developmental environments (Fig. 3B). Mechanistically life history patterns can be modeled as l_x and m_x schedules where l_x is probability of survival to age x and m_x is age-specific reproduction. Thus, an organism of a given life history type will have different l_x and m_x schedules in different developmental environments (Fig. 3C). Hypothetical distribution of life history types composing a stock along an axis of developmental environments is shown in Figure 3D. The different types are adapted to different ranges of environments.

In this view, variation in life history performance (eg. $\sum l_x m_x$) within a stock is a consequence of the existence of different life history types having different capacities, with different environments. Maintenance of life history

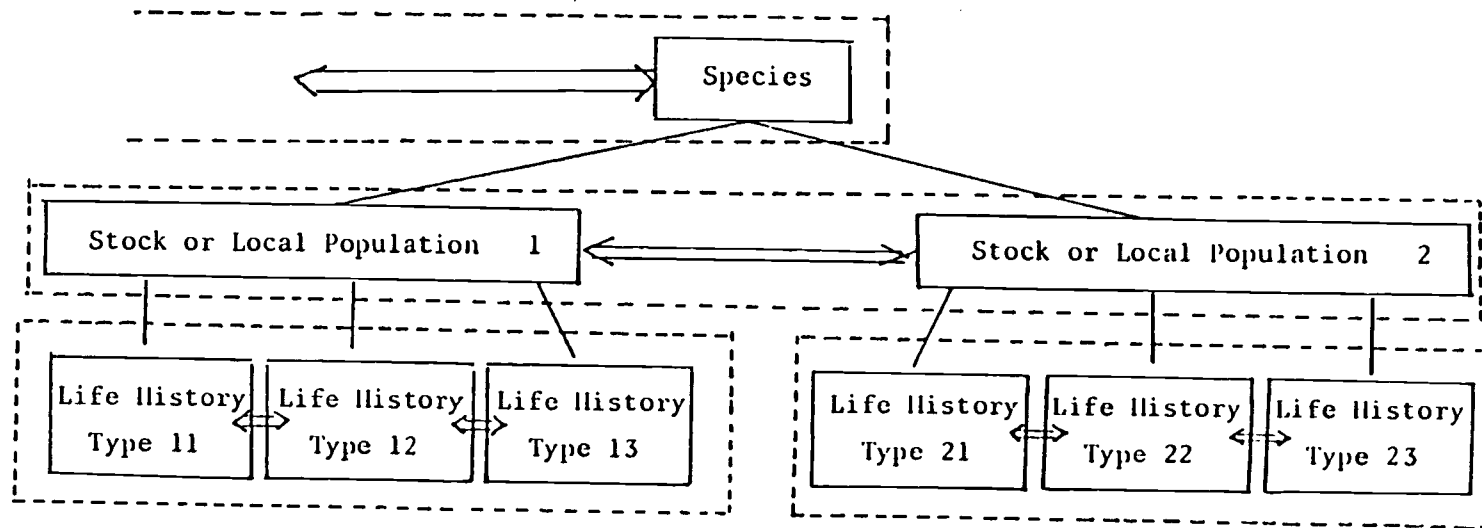

Figure 1. Hierarchical Structure of a Species

Figure 2. Potential adaptive capacities and developmental states of species, populations or stocks, and individual life history types in different environments. At each developmental state the species, population, or individual has a state specific realized capacity and organization determined by its potential capacity and the state of its environment. a) Species evolve along different trajectories in different environments. b) Stocks or local populations have the capacity to evolve in concordance with their environments. c) The life history adaptive capacity of the individual organism allows for the development of different life history patterns in different environments.

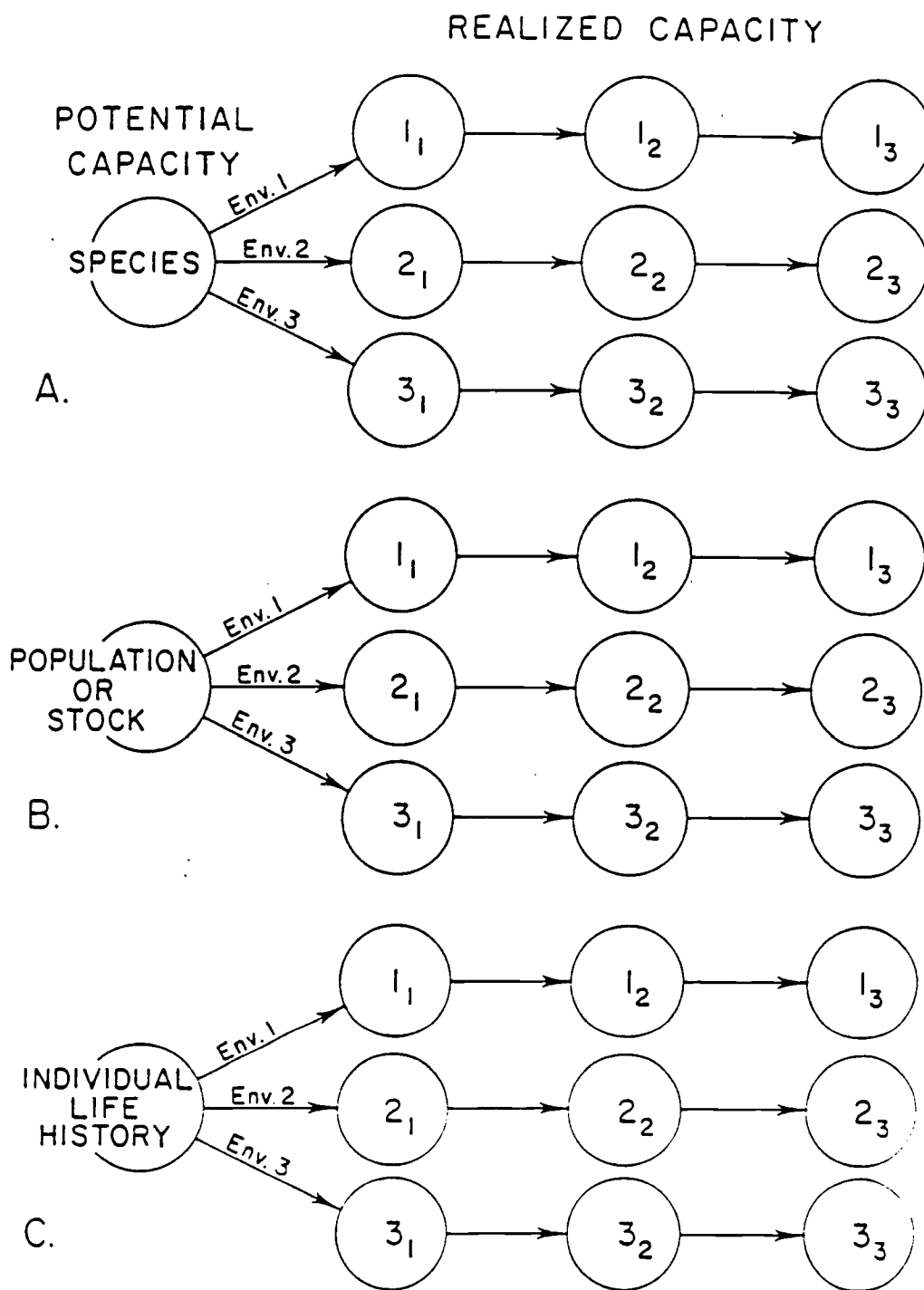

Figure 2.

Figure 3. A. The life history theory presented here is based on a conceptual framework developed by Warren et.al 1979. System development/evolution is change in realized capacity. The performances of a system at any time in its development are jointly determined by its realized capacity and conditions in its environment at that time. System development is jointly determined by the system's potential capacity and its developmental environment (DE). B. Interpretation of A for the life history of an individual organism. An organism's life history or developmental pattern is determined both by the environment in which the organism develops and its life history (ie, potential) capacity, which can be taken to reside in its genotype. C. Model of B focusing only on demographic or numerical properties of a life history, namely age-specific survival (l_x) and reproduction (m_x). An organism's demographic performance at each stage or age in its development can be modeled as the product $l_{ijx}m_{ijx}$ where i designated life history type and j is developmental environment. Demographic developmental pattern for type i in environment j can be designated as $\sum l_{ijx}m_{ijx}$. D. Life history performance, $\sum l_{ijx}m_{ijx}$, of five life history types composing a stock.

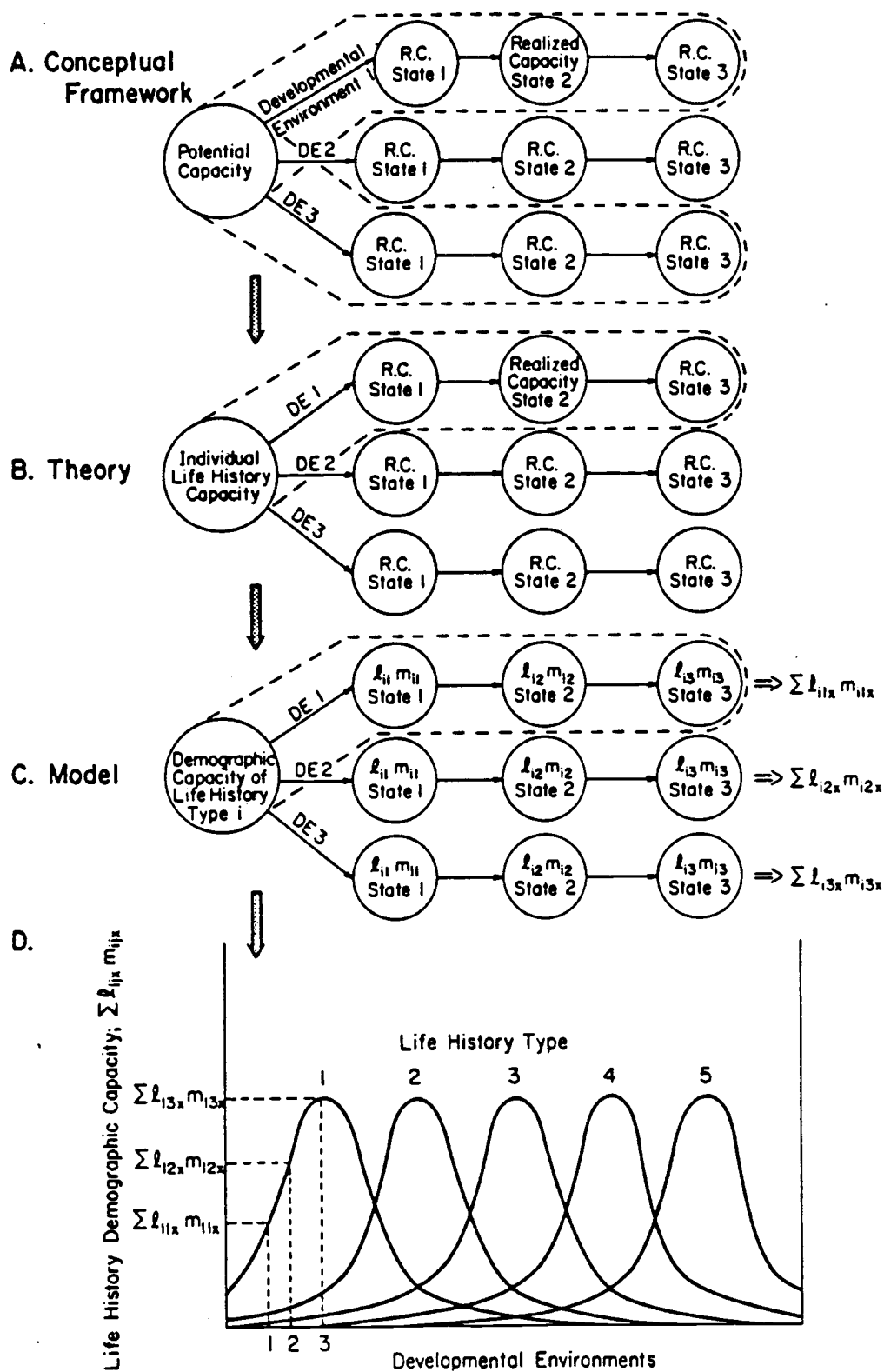

Figure 3.

diversity is a way in which populations adapt to spatially and temporally variable environments.

The theory of spreading of risk (den Boer 1968, Andrewartha and Birch 1984) implies that maintenance of a diversity of life history types in a population tends to buffer the effect of environmental change and stabilize numerical performance (change in density, yield) of stocks. The different life history types composing the population are taken to be adapted to somewhat different sets of environmental conditions (Fig. 3D). At a given time the environment may be more favorable for survival and reproduction of some life history types and less favorable for others. As the environment changes, life history types that are increasing in abundance may tend to offset those that are decreasing, leading to enhanced persistence and greater stability of the numerical properties of the stocks. Thus populations maintaining diverse life history organizations may be less variable in abundance and be able to persist for longer periods of time than populations with less diverse life history types. Selective harvesting of life history types, hatchery operations, destruction of habitat and other human activities could lead to loss of life history diversity and consequently to greater variability in densities and yield and increased probability of extinction.

MODEL DEVELOPMENT

The analysis is based on a computer model, developed with Pascal language, of hypothetical natural populations composed of five different life history types. For each life history type, it is assumed that the age-specific life table (s_x and m_x) varies with changing environments and population density, so that age distribution within the population is not constant and stable age structure cannot be expected. Furthermore, it is assumed that different life history types are adapted to different ranges of environmental conditions, as suggested in Figure 1. It is also assumed that environmental conditions change from year to year but are constant within a year and organisms reproduce at the end of the year. The influence of different levels of fishing that selectively harvest life history types (ie., some types have higher fishing mortality than others) and that are nonselective will be examined.

Environmental Condition

The environment experienced by the hypothetical population was divided into thirty different "environmental states" designated by numbers 1-30. An environmental pattern consists of yearly changes in environmental states for 100 consecutive years. Since the response of the population to a particular fishing regime (ie., a given

level of selective or nonselective harvest) is contingent on the environmental pattern, each regime was evaluated for 20 different environmental patterns. The sequence of environmental states composing each pattern was determined by computer through random selection of environmental states from a trapezoidal frequency distribution of states (ie., environmental states designated by lower and higher number such as 1-5 and 25-30 occur less frequently than others).

Age-specific life tables : m_x and l_x schedules

M_x is defined as the number of daughters born in the interval t to $t+1$ per female aged x to $x+1$ at time t . The probability at birth of an individual reaching the start of age x is designated as l_x . The life history types in the population differ in the range of environmental states to which they are adapted, as suggested in Figure 3D, and thus will have different sets of l_x and m_x schedules.

An important aspect of a life table for each life history type is the way that m_x and l_x schedules vary with age. Although there may be many patterns of age variation in l_x and m_x for different kinds of organisms, the general pattern described by Emlen (1970) and Schaeffer (1979) was used to construct the model. M_x increased with age to a peak at an intermediate age and then declined. Age-specific mortality declined to a minimum prior to the earliest reproductive age (age 3) and then increased.

Variability in the Life Table

It is reasonable to assume that environmental change may reduce or increase the reproduction and survival of organisms. Thus l_x and m_x schedules for a particular life history type depend upon environmental conditions and change through time as the environment changes. The relationship between l_x and m_x and environmental states E for life history type i is :

$$m_{ix} = m_{ix,op} \text{ Exp } -(E_{iop} - E)^2 / C_1$$

$$l_{ix} = l_{ix,op} \text{ Exp } -(E_{iop} - E)^2 / C_2$$

where $m_{ix,op}$ and $l_{ix,op}$ are the optimal reproduction and survival rates at the optimal environmental state E_{op} and C_1 and C_2 indicate the degree of dispersion of the curve from the optimal value. Each curve is symmetrical about its optimal condition (Fig. 4). The life history types composing the population have different E_{op} . In this model, then, the forms of the relationship between l_x and m_x and environmental state (Fig. 3D) are identical for the different life history types, but the different types have different E_{op} and so occur at different locations along the environmental state axis. Thus the different life history types are adapted to different ranges of environmental states. Life history types composing natural populations

Figure 4. General form of l_x and m_x curves of a life history type. Curves for different life history types occupy different ranges of environmental states. Both curves are symmetrical about the optimal condition. Depending on the deviation from the optimal, l_x and m_x value decrease and disperse when the environmental condition become unfavorable.

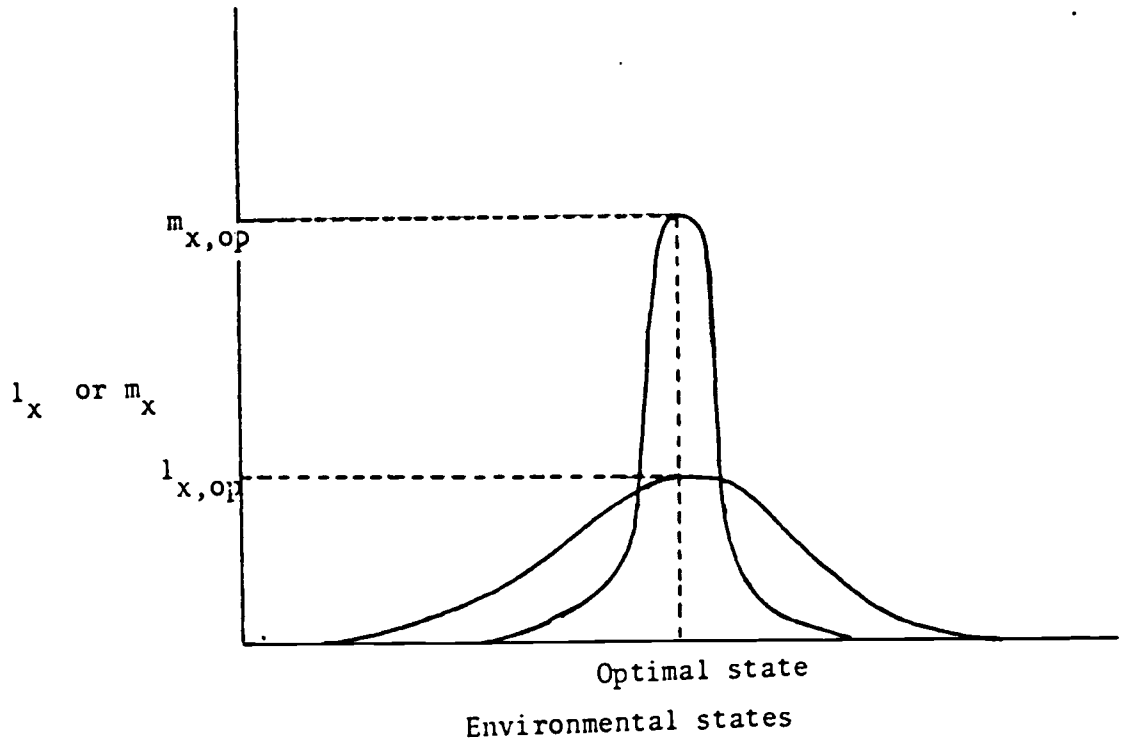

Figure 4.

surely must differ not only in range of environmental states but also in the form of l_x and m_x curves.

Density Dependent Factors

"Density-dependence" and "density-independence" are often viewed as dichotomous processes in natural populations. Yet many biologists would agree that both processes operate together to influence population density. Enright (1976) argued that factors that operate in a density-independent manner (eg. physical factors such as temperature) set the upper and lower limits for birth and death rate, respectively, while at any given level of this set of factors, rates change in a density-dependent manner. Density-dependence is necessary in this model to prevent populations from reaching extremely high densities. Thus, for each environmental state, age-specific survival and reproduction for each life history type are assumed to be density-dependent (Enright 1976), as shown in Figure 5. Change in environmental state shifts the position of the density-dependent relationships for all age groups.

Genetic Structure of the Hypothetical Population

A genetic component is needed to deal with reproduction between life history types. The model uses two loci with two alleles, so that there are four kinds of gametes, AB, Ab, aB and ab, in the gamete pool. Each life history type

Figure 5. Density-dependent relationships for mortality and reproduction. A. Mortality rate, $(1-S_x)$ and reproduction rate, M_x of life history type i aged j vary with both environmental states, E and population density, N . A_{E_i} is the upper limit of m_x and B_{E_i} the lower limit of mortality rate of $(1-S_x)$ set by density-independent operation of E_i . B. Relationship of life history performance, $l_x m_x$, to environmental state E_i and population density N_i for different life history types.

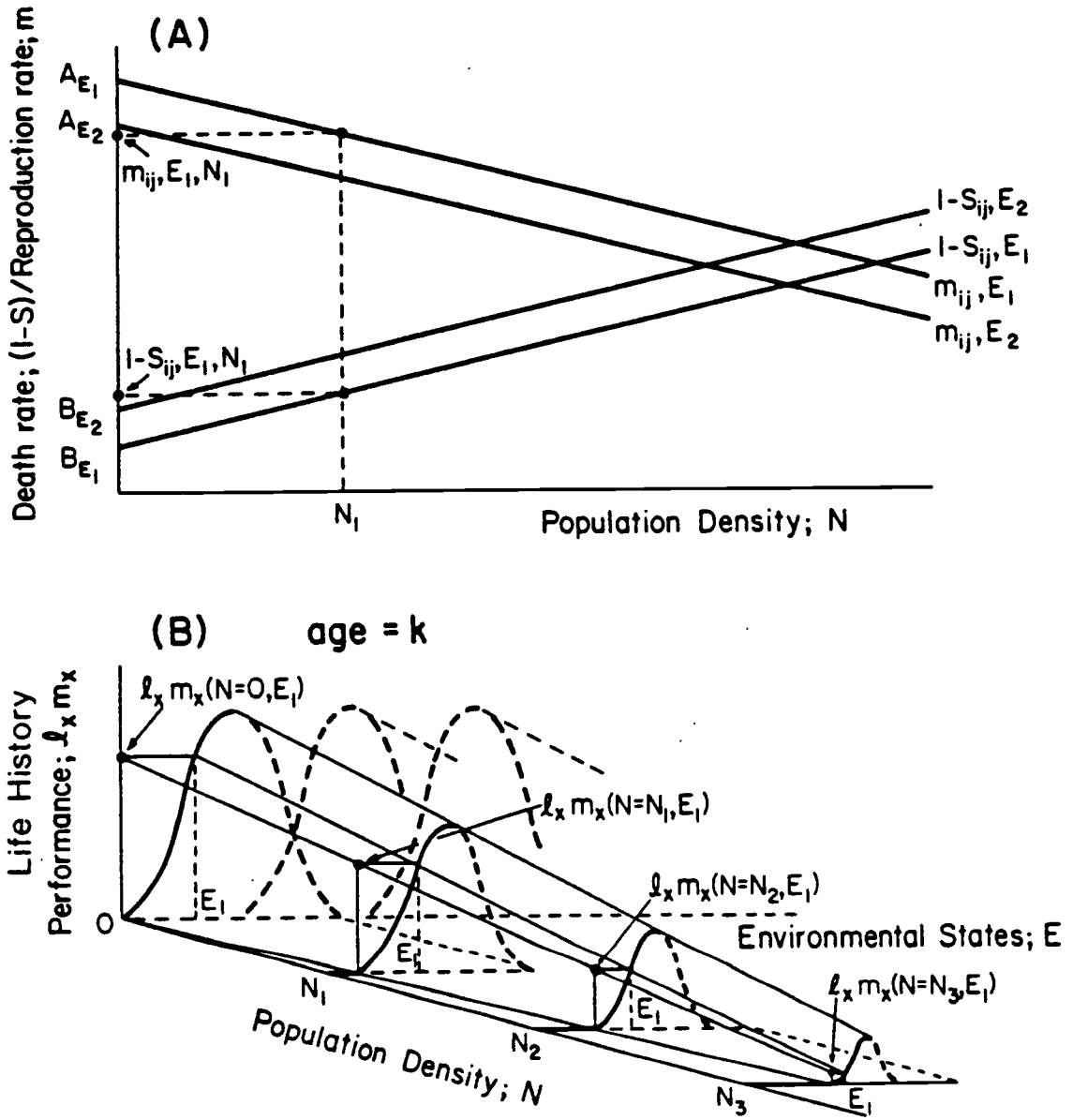

Figure 5.

is represented by one or more genotypes: life history type 1 is represented as AB/AB; life history type 2 as AB/Ab and AB/aB; life history type 3 as AB/ab, Ab/aB, Ab/Ab and aB/aB; life history type 4 as Ab/ab and aB/ab; and life history type 5 as ab/ab. No dominance is assumed; genotypes are simply used as markers for life history types to determine the life history types of progeny resulting from mating of different or similar parental types. An advantage of a genetic approach is that reproductive capacity can be modeled, that is, a given life history type has the capacity to produce a diversity of life history types in its progeny. Thus a mating of AABb (type 2) and AaBb (type 3) produces progeny of type 1 and 4 as well as 2 and 3. A problem is that in such a simple genetic model life history types are completely broken up and reconstituted anew every year. This certainly does not occur in natural populations.

Since mutation rates are usually very low, the role of mutation in influencing gene frequencies is ignored in the model. Recombination in the double heterozygotes is an important source of gene variation and cannot be generally ignored, thus the recombination fraction, r , is assumed to be 0.5.

Mating Mechanism : Random Mating

Random mating was incorporated into the model. In natural population, mating is probably not completely

random. For this model, however, it was assumed that zygotes were formed by random union of gametes within the whole population. That is, a particular life history type had an equal probability of mating with all other life history types within the population. Based on the definition of m_x , each mother reproduces gametes according to the value of m_x . For example, a mother of genotype AB/Ab (life history type 2) will produce one gamete of AB and another gamete of Ab if the m_x value is one. Therefore, the total number of gametes in the gamete pool after breeding, G , is ;

$$G = 2 \sum_i \sum_j n_{ij} m_{ij} \quad (1)$$

where n_{ij} is the number of individuals of zygote type i aged j and m_{ij} is the m_x value for the individual of zygote type i aged j . The total number of each of the four gametes is as follows :

$$G_{AB} = \sum_j [2n_{1j}m_{1j} + n_{2j}m_{2j} + n_{3j}m_{3j} + (1-r)n_{4j}m_{4j} + rn_{5j}m_{5j}] \quad (2)$$

$$G_{Ab} = \sum_j [n_{2j}m_{2j} + rn_{4j}m_{4j} + (1-r)n_{5j}m_{5j} + 2n_{6j}m_{6j} + n_{8j}m_{8j}] \quad (3)$$

$$G_{aB} = \sum_j [n_{3j}m_{3j} + (1-r)n_{4j}m_{4j} + rn_{5j}m_{5j} + 2n_{7j}m_{7j} + n_{9j}m_{9j}] \quad (4)$$

$$G_{ab} = \sum_j [rn_{4j}m_{4j} + (1-r)n_{5j}m_{5j} + n_{8j}m_{8j} + n_{9j}m_{9j} + 2n_{10j}m_{10j}] \quad (5)$$

$$G = G_{AB} + G_{Ab} + G_{aB} + G_{ab} \quad (6)$$

From equations (2) through (5) the frequency of each gamete type in the gamete pool after breeding can be easily calculated and is denoted as X_i ($i = 1..4$) :

<u>Gamete Type</u>	<u>Frequency</u>
AB	$X_1 = G_{AB} / G$
Ab	$X_2 = G_{Ab} / G$
aB	$X_3 = G_{aB} / G$
ab	$X_4 = G_{ab} / G$

The sum of the X's is one. Again, since the zygotes are formed by random union of gametes and the gametes segregate independently, the frequency of each zygote type can be calculated as in Table 1. Similar to equation (1), the total number of newly reproduced offspring, B, can be calculated by equation (7) :

$$B = G / 2 = \sum_i \sum_j n_{ij} m_{ij} \quad (7)$$

Therefore, the number of newly born offspring of zygote type AB/AB is calculated as follow and denoted as

$$B_1 = B * X_1^2 \quad (8)$$

The number of offspring of other genotypes are similarly calculated (Table 1).

Table 1. Random Mating Mechanism.

Gametic Output at Breeding		Zygote Newly Reproduced		
Number	Frequency	Frequency	Zygote Type	L.H.Type
G _{AB}	X ₁	X ₁ ²	AB/AB	1
G _{Ab}	X ₂	2X ₁ X ₂	AB/Ab	2
G _{aB}	X ₃	2X ₁ X ₃	AB/aB	
G _{ab}	X ₄ of Gametes	2X ₁ X ₄	AB/ab	3
		2X ₂ X ₃	Ab/aB	
		X ₂ ²	Ab/Ab	4
		X ₃ ²	aB/aB	
		2X ₂ X ₄	Ab/ab	5
		2X ₃ X ₄	aB/ab	
		X ₄ ²	ab/ab	

$$B = 1/2 \sum_i \sum_j n_{ij} m_{ij} \quad \text{Total number of offspring newly reproduced.}$$

therefore,

$$B_1 = B * X_1^2 \quad \text{Total number of offspring for zygote type 1 newly reproduced.}$$

Similarly for other zygote types,

$$\begin{aligned} B_2 &= B * 2X_1X_2 \\ B_3 &= B * 2X_1X_3 \\ B_4 &= B * 2X_1X_4 \\ B_5 &= B * 2X_2X_3 \end{aligned}$$

$$B_6 = B * X_2^2$$

$$B_7 = B * X_3^2$$

$$B_8 = B * 2X_2X_4$$

$$B_9 = B * 2X_3X_4$$

$$B_{10} = B * X_4^2$$

Fishing Effort

Suppose that the only causes of mortality in a population during a year are fishing and natural mortality. Then the simplest numerical representation of mortality is;

$$N_{t+1} / N_t = e^{-(F+Z)}$$

the parameters F and Z are the instantaneous fishing mortality rate and the instantaneous natural mortality rate, respectively. Based on this, abundance of life history type i in successive years can be computed as :

$$N_{ij}(t+1) = N_{ijt} * e^{-(F+Z_{ij})} = N_{ijt} * S_{ij} * e^{-F}$$

where S_{ij} is the discrete survival rate of life history type i aged j which could be calculated from the l_x schedule and N_{ijt} and $N_{ij}(t+1)$ are the number of individuals of life history type i aged j at time t and $t+1$.

The hypothetical population is composed of genetically different life history types. Three harvesting strategies, nonselective, selective harvest 1, and selective harvest 2 are applied. For each harvesting strategy the population will be subjected to levels of fishing mortality F of 0.0, 0.30, 0.50 and 0.65. In the case of nonselective harvest the effort (mortality) is distributed evenly over all life history types, that is, types 1-5 will all be harvested at the same rate. In the case of selective fishing, life history types will be exposed to different levels of fishing

effort (mortality). The relationship can be quantitatively expressed as follows:

$$\sum_i N_i = N$$

$$\sum_i C_3 Y_i N_i = C_3 \sum_i Y_i N_i = \sum_i N_i * e^{-F_i} = \sum_i N_i * U_i = N * e^{-F}$$

where N_i is the number of fishable individuals of life history type i and N is the total number of individuals in the whole population. Y_i is the selectivity coefficient for life history type i and C_3 is coefficient of fishing pressure. The expression $C_3 * Y_i$ indicates the fishing pressure on life history type i when instantaneous fishing pressure F is influencing the whole population. Therefore, if the selectivity for every life history type is the same, $Y_1 = Y_2 = Y_3 = Y_4 = Y_5$, the case is one of nonselective fishing pressure. Otherwise, fishing pressure is selective.

Selective harvest strategy 1 assigns selectivity ratios 5, 5, 3, 1 and 1 to life history types 1, 2, 3, 4 and 5, respectively. Selective harvest strategy 2 assigns the ratios 1, 3, 5, 3 and 1 to these types. All harvesting began at year 20 for each environmental regime.

Population Projection

Figure 6 diagrammatically illustrates the mechanism of population projection. The number of female offspring of life history type i produced at time t is defined as $R_i(t)$.

The expected number of individuals of age k of type i at time t is defined by $n_{i,k}(t)$ ($i = 1, 2, 3, 4, 5$; $k = 1, 2, 3, 4, 5, 6, 7$). Then,

$$\begin{aligned} n_{i,1}(t+1) &= R_i(t) S_0(N_t, E_t) \\ n_{i,2}(t+1) &= n_{i,1}(t) S_1(N_t, E_t) \\ &= R_i(t-1) S_0(N_{t-1}, E_{t-1}) S_1(N_t, E_t) \\ n_{i,k}(t+1) &= n_{i,k-1}(t) (1-U_i) S_{k-1}(N_t, E_t) \\ &= R_i(t-k) (1-U_i)^{k-2} \prod_{x=0}^k S_x(N_{t-k-x}, E_{t-k-x}) \quad (k > 3) \end{aligned}$$

where U_i equals e^{-F_i} for life history type i , s_x is survival rate from age x to $x+1$, E_t is the environmental state over time interval t to $t+1$, and N_t is total population density at time t . Survival rate is a function of the environmental state and population density at a particular time. As a hypothetical example, $S_3(N_{t-1}, E_{t-1})$ is the survival rate from age 3 to 4 under a particular environmental state at time $t-1$. Individuals of age 4 of life history type 1 at time t , $n_{1,4}(t)$, must have been recruited 4 years ago as $R_1(t-4)$. They have been exposed not only to different environmental conditions each year but also to fishing pressure after age 2. Therefore, the probability that the individuals can survive to time t from the recruitment is :

$$\begin{aligned} S_0(N_{t-4}, E_{t-4}) S_1(N_{t-3}, E_{t-3}) S_2(N_{t-2}, E_{t-2}) \\ S_3(N_{t-1}, E_{t-1}) (1-U_i)^{k-2} \end{aligned}$$

and the number of individuals is :

$$\begin{aligned}
 n_{1,4}(t) &= R_1(t-4) S_0(N_{t-4}, E_{t-4}) S_1(N_{t-3}, E_{t-3}) \\
 &\quad S_2(N_{t-2}, E_{t-2}) S_3(N_{t-1}, E_{t-1}) (1-U_i)^{k-2} \\
 &= R_1(t-4) (1-U_i)^{k-2} \prod_{x=0}^4 S_x(N_{t-k-x}, E_{t-k-x})
 \end{aligned}$$

Reproduction begins at age 3. M_{ik} is the number of female offspring born from the parents of life history type i aged k during the interval of time t to $t+1$ and is a function of the environmental state and the density at time t , $m_{ik}(N_t, E_t)$. The number of female offspring born from parents aged k of life history type 1 is :

$$\begin{aligned}
 B_k(t+1) &= \sum_{i=1}^5 n_{i,k}(t+1) m_{i,k}(N_t, E_t) \\
 R(t+1) &= \sum_{k=3}^7 B_k(t+1) = \sum_{k=3}^7 \sum_{i=1}^5 n_{ik}(t+1) m_{ik}(N_t, E_t)
 \end{aligned}$$

Offspring are not always of the same life history type as parents. The life history types composing $R(t+1)$ is determined by the genetic model. Some of these types will be type i , $R_i(t+1)$.

For a discrete case, the abundance of a life history type can be calculated by a matrix equation (Leslie 1948) :

Figure 6. Diagrammatic illustration of the life history mechanism of the model. $R_i(t)$ represents recruitment of life history type i ($i = 1, 2, 3, 4, 5$) at time t . $N_{ik}(t)$ is the number of individuals at age k ($k = 1, 2, 3, 4, 5, 6, 7$) in life history type i at time t . The equations for each transition from time t to time $t+1$ indicate the probability of survival for each age class where U_i is the harvesting rate on life history type i and S_{ik} is the survival rate ($1 -$ mortality rate) of life history type i for age class k . The age specific survival rate is a function of environmental condition (E_t) and population density (N_t). At time $t+1$ the surviving population reproduces by means of a random mating model (Genetic Model). A particular life history type i may produce offspring of any life history type. B_k ($k = 3, 4, 5, 6, 7$) represents the number of offspring produced by parent of age class k . This population becomes the recruitment of the population at time $t+1$. From this population the cycle begins again for the next generation.

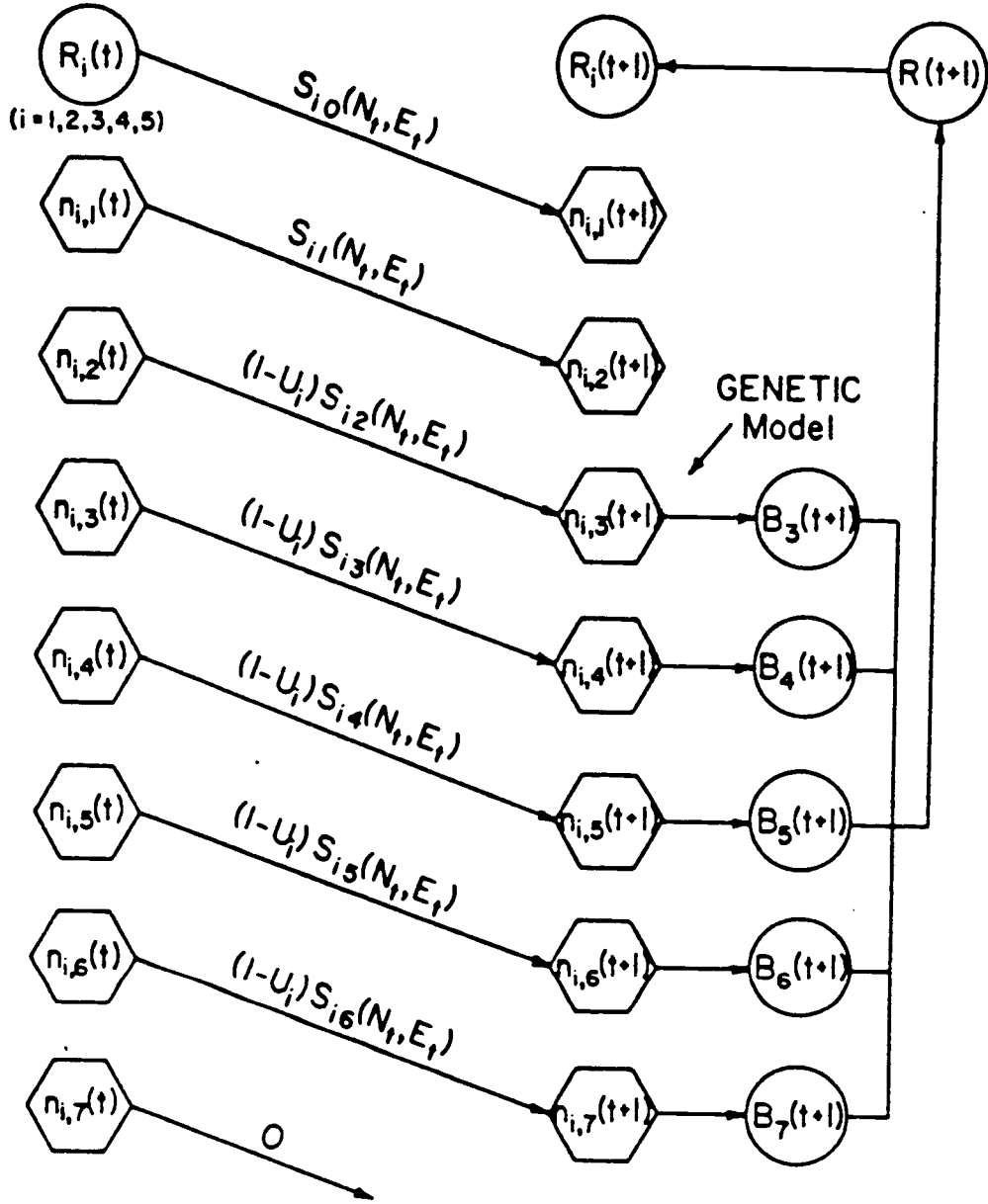

Figure 6.

$$\begin{array}{cccc|ccc}
 m_{ij0N} & , & m_{ij1N} & , & - & - & m_{ijk-1N}, & m_{ijkN} & \left| \begin{array}{c} n_{i0} \\ n_{i1} \\ n_{i2} \\ \vdots \\ n_{ik} \end{array} \right| & \left| \begin{array}{c} N_{i0} \\ N_{i1} \\ N_{i2} \\ \vdots \\ N_{ik} \end{array} \right| \\
 (1-U_i)s_{ij0N}, & & 0 & , & - & - & 0 & , & 0 & \\
 0 & , & (1-U_i)s_{ij1N}, & - & - & & 0 & , & 0 & \\
 & & & & & & & & & = \\
 0 & , & 0 & , & - & - & (1-U_i)s_{ijkN}, & 0 & &
 \end{array}$$

(9)

where m_{ijkN} is equivalent to the m_x schedule for individuals of life history type i aged k at environmental state j and population density N (to incorporate density-dependence). S_x is the probability that females of age x at time t will survive to age $x+1$ at time $t+1$. S_x is defined as l_{x+1}/l_x . S_{ijkN} is the age-specific survival for individuals of life history type i aged k at environmental state j and population density N . The n_k and N_k indicate the number of individuals of age k at times t and $t+1$, respectively.

After the environmental state is selected for a given year, for each life history type, s_x and m_x schedules specific to that environment and population density N are used to project abundance for the following year according to equation 9.

Analysis

Five approaches will mainly be used to synthesize the vast amount of information generated by the model to

evaluate the generalizations.

Extinction

Increased fishing effort, selective harvest, and consequent loss of life history diversity should decrease the persistence of populations. Since extinction of populations and life history types is a useful way of assessing persistence, the number of cases of extinction out of 20 different environmental regimes at each harvesting rate was determined.

Short Term Variance

According to the theory of spreading of risk, as the diversity of life history types is reduced, fluctuations in population abundance and yield will increase. To evaluate variation in abundance and yield of each life history type and the population, the average absolute value of residuals (A.V.R) of locally weighted regressions (A.V.R) was calculated, as shown in Figure 7 (Cleveland 1979).

$$A.V.R = \sum_{i=1}^n A_i / n$$

where n is the number of data points (=100).

Diversity Index

To evaluate change in life history diversity through

time, Simpson's (1949) diversity index, D , was used :

$$D = 1 / \sum_i p_i$$

where p_i is the proportion of individuals in life history type i , that is, $p_i = N_i / N$. This index varies from 1 (one dominant life history type) to 5 (completely even distribution). The index was calculated on the basis of population life history composition for each year and the terminal diversity index (T.D.I) at year 100 (termination of simulation for each environmental pattern) is used for comparison between fishing regimes.

Mean Density, Terminal Density and Catch

Numerical performance for each life history type and the population was influenced by changing environments and selective and nonselective fishing effort. The mean density and the total catch over 100 years were used to evaluate numerical performance for each environment pattern under each fishing regime. Terminal density at year 100 was used to assess accumulated effects of fishing pressure on the population.

Figure 7. Trends in population abundance under a particular environmental pattern when the population is selectively harvested. Solid line is a locally weighted regression line. Open circles indicate the population trajectory. Short term variance is determined as the average of the absolute value of deviations of each point on trajectory from the solid line, as shown by A.

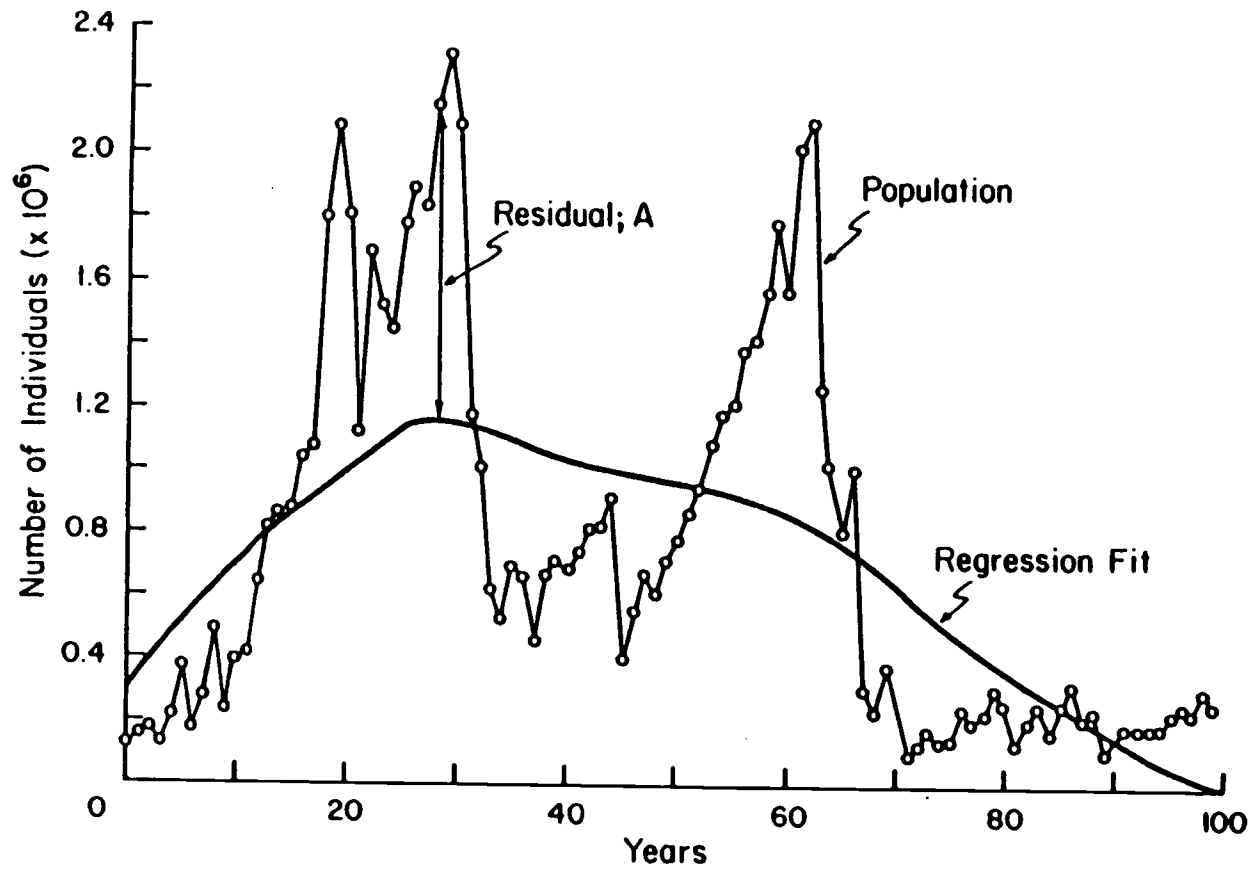

Figure 7.

RESULTS AND INTERPRETATION

Dynamics of Unharvested Stock

Results of simulation runs for 20 different environmental regimes, with no harvesting effort, are given in Table 2. Each environmental regime represents a different pattern of changing environmental conditions for 100 years. The simulated populations exhibited different numerical performances under different environmental regimes. The different regimes cause changes in population life history composition which in turn affect population numerical performance.

In a changing environment, the life history composition of populations changes continuously. Figure 8 shows the relationship between environmental variation, population abundance, and life history composition for environmental regime 14 with no harvesting effort. For the first 35 - 40 years of the simulation, the environment fluctuated in a range which was most suitable for life history type 3, 4 and 5 (Fig. 8A). Then, it shifted and stayed in a range more suitable for types 4 and 5 until about year 70. After year 70, the environment again shifted to a range which was most suitable for types 1, 2 and 3.

Environmental variation results in change in population life history composition. That is, the population adjusts its composition in adapting to changing environmental

Table 2. Summary of population performance under 20 different environmental regimes with no harvesting effort. Units of mean abundance, terminal abundance and A.V.R are (x1000).

Environ. Regime	Mean Abundance	Terminal Abundance	A.V.R _a	T.D.I _b
1	7968	8692	1354.6	3.483
2	8533	10164	1621.3	2.678
3	8358	10199	1253.9	3.494
4	7315	8677	1901.8	3.525
5	8109	8364	1378.4	3.468
6	6790	7967	1629.5	3.537
7	7426	11924	1485.3	3.392
8	7881	4038	1497.4	3.646
9	7726	11006	1236.1	3.395
10	7617	5958	1904.1	3.354
11	7056	11382	1693.4	3.109
12	8287	8537	1491.6	3.552
13	7850	6375	1570.1	3.564
14	8513	12270	1872.9	3.511
15	7997	12105	1599.3	3.367
16	8419	9124	1515.4	3.458
17	7351	9932	1396.7	3.269
18	6549	7543	1506.2	3.585
19	8091	10362	1780.1	3.541
20	7999	11990	1359.9	3.535
	7792	9331	1552.4	3.423

a. Absolute Value of the Residual.

b. Terminal Diversity Index.

Figure 8. Relationships between environmental variation, population life history diversity and population abundance under no harvesting conditions (environmental regime 14). A. Pattern of environmental variation for environmental regime 14. Brackets indicate ranges of environmental states over which each life history type can survive and reproduce. B. Changes in population density under environmental regime 14 with no harvesting effort. C. Changes in the life history diversity index over the 100 year period. D. Changes in frequency of life history types.

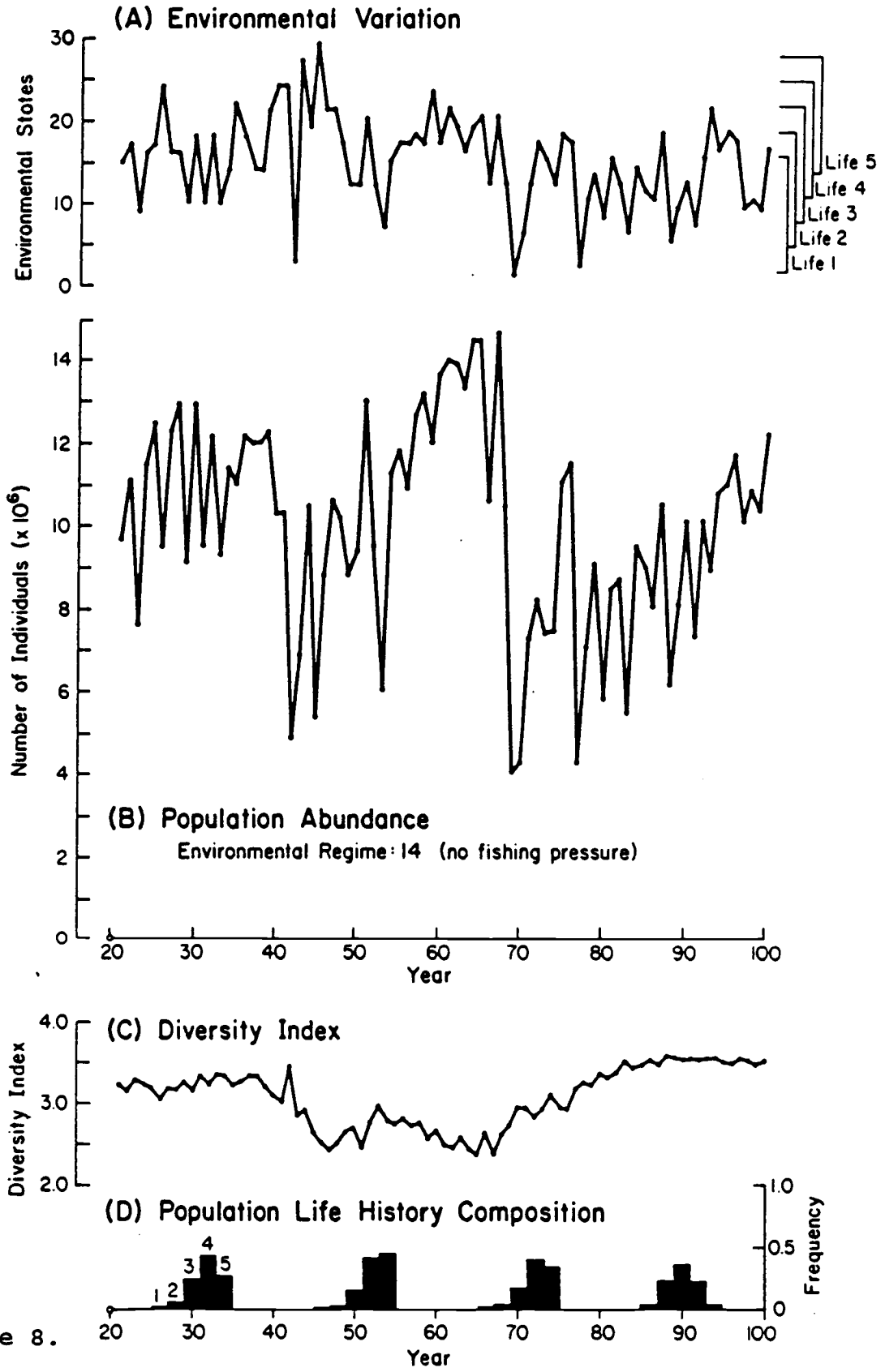

Figure 8.

conditions. For example, from year 20 to year 40, the distribution of life history types was slightly skewed to life history types 3, 4 and 5, which were favored by the particular environmental sequence occurring over those years (Fig. 8D). The diversity index was maintained at a relatively high level (Fig. 8C). However, when the environmental sequence changed toward a more suitable range for life history types 4 and 5 (years 35 to 70), these life history types were favored by selection and the abundances of types 1, 2 and 3 were reduced. Life history types 4 and 5 become dominant and this lead to a reduction of the diversity index. Afterwards, the environmental sequence again shifted to a range more suitable for life history types 1, 2 and 3, the distribution of types became normal, and the diversity index increased.

Changes in population abundance are related to changes in environmental state and life history composition. If an environmental sequence is suitable for a particular life history composition, the population will maintain a high numerical abundance with fewer fluctuations, such as during the time periods from year 20 to 40 and from year 54 to year 68 in Figure 8B. However, when there occurs a sudden change in environmental conditions which are unsuitable for the particular population composition at that time, population abundance quickly become depressed, as occurred at around years 40 and 70. However, if the population maintains its

adaptive capacity, population composition is able to adjust to fit to the new environmental sequence. Thus, the population, sooner or later, can return to a high level of abundance, as occurred from year 77 to 100 in Figure 8B.

Effects of Increased Harvesting Effort

An increase in harvest effort reduced mean abundance, terminal abundance (with a number of extinctions occurring at $F = 0.65$), and total catch (Table 3 - 5). The absolute value of the residual (A.V.R) was higher in the unharvested than in the harvested stocks, indicating greater variability in abundance of the unexploited populations. The terminal diversity index (T.D.I) was not greatly affected by increased harvesting effort. Nonselectively harvested stocks maintained about the same life history diversity as unharvested stocks. Average T.D.I was severely depressed in selectively harvested stocks, in comparison with unharvested and nonselectively harvested populations.

Effects of Selective and Nonselective Harvesting

Figure 9 shows the effects of nonselective and selective harvesting under environmental regime 14 at $F = 0.5$. As mentioned above, for the first 4 decades the environmental sequence was most suitable for life history types 3, 4 and 5. For the next 3 decades, it shifted to a range more suitable for types 4 and 5, and for the last 2

Table 3. Summary of influences of selective and nonselective harvest at fishing mortality of 0.3. Selectivity coefficients for life history types 1 through 5 are shown for populations that are selectively harvested. Units of mean abundance, terminal abundance, catch and A.V.R are (x1000).

Environ. Regime	Nonselective						Summary (Fishing Mortality 0.3)						Selective 2 [1,3,5,3,1]					
	Mean Abundance	Terminal Abundance	Catch	a. A.V.R	b. T.D.I		Selective 1 [5,5,3,1,1]			a. A.V.R	b. T.D.I	Mean Abundance	Terminal Abundance	Catch	a. A.V.R	b. T.D.I		
							Mean Abundance	Terminal Abundance	Catch									
1	3403	2140	30445	714.6	3.451		3298	1793	22673	1055.4	1.587	3243	1333	21732	1102.6	1.000		
2	3929	3640	29811	1021.5	2.640		2261	1842	17559	859.2	2.374	4215	3160	30385	1348.8	1.000		
3	3664	4157	30737	549.6	3.448		3239	5475	26789	680.2	1.728	2730	4299	21986	627.9	1.000		
4	2608	2370	23867	965.0	3.524		2477	1857	22194	1015.6	1.972	1933	779	16779	1043.8	1.000		
5	3436	3304	27277	721.6	3.452		2966	735	22720	1038.1	2.356	2689	419	19865	950.1	1.000		
6	2338	1313	22942	561.1	3.526		2274	460	18134	773.2	1.975	1625	492	12820	633.8	1.000		
7	2635	5194	21250	606.1	3.345		1901	1608	13966	532.3	2.326	2488	4236	19036	746.4	1.000		
8	3383	1077	30823	710.4	3.593		2528	1150	18989	758.4	1.670	3378	270	29246	878.3	1.006		
9	3041	4323	23338	638.6	3.372		2348	1610	17616	727.9	2.207	2800	3902	19855	840.0	1.000		
10	2994	1631	26498	1047.9	3.360		2819	1711	19991	1268.6	1.475	2848	1664	26255	1338.6	1.001		
11	2286	4853	18127	731.5	3.032		2689	4293	23446	968.1	1.492	2384	3948	16522	1001.3	1.000		
12	3686	2724	31717	810.9	3.540		3793	1628	31944	1024.1	1.795	3429	1520	29396	891.5	1.014		
13	3146	2439	27062	755.0	3.559		2882	2541	23474	893.4	1.678	2366	1924	20085	804.4	1.000		
14	3911	4248	31956	1212.4	3.481		3631	949	27934	1234.5	2.369	3563	300	26064	1247.1	1.000		
15	3383	4215	28552	913.4	3.259		3596	7435	24445	791.1	1.407	2680	84	18580	1098.8	1.000		
16	3745	3629	30201	973.7	3.434		3880	2867	35528	1086.4	1.656	3219	3005	21275	1036.5	3.129		
17	2729	2841	25776	518.5	3.261		1517	1103	16275	439.9	2.151	2766	2066	24671	719.2	1.000		
18	1936	1461	17356	522.7	3.357		1750	842	13219	612.5	1.807	1445	348	12865	491.3	1.000		
19	3404	3312	25509	1055.2	3.522		3355	4520	22487	1140.7	1.691	2484	451	17075	1242.0	1.000		
20	3401	3585	28583	714.2	3.540		2882	2654	24882	893.4	1.730	2974	524	20861	832.7	1.000		
Average	3152.9	3122.8	26591.4	787.2	3.385		2804.3	2353.7	22213.3	889.7	1.872	2764.0	1736.2	21267.7	943.8	1.108		

a. Absolute value of residual.
b. Terminal life history diversity index.

Table 4. Summary of influence of selective and nonselective harvest at a fishing mortality of 0.5. Selectivity coefficients for life history types 1 through 5 are shown for population that are selectively harvested. Units of mean abundance, terminal abundance, catch and A.V.R are (x1000).

Environ. Regime	Nonselective					Summary (Fishing Mortality 0.5)					Selective 2 (1,3,5,3,1)				
	Mean Abundance	Terminal Abundance	Catch	A.V.R	T.D.I	Selective 1 (5,3,3,1,1)					Mean Abundance	Terminal Abundance	Catch	A.V.R	T.D.I
						Mean Abundance	Terminal Abundance	Catch	A.V.R	T.D.I					
1	1292	125	12097	452.2	3.429	1355	78	12589	623.3	1.449	1377	53	13841	633.4	1.000
2	1419	620	13348	624.4	2.574	812	3	6113	503.4	2.063	1824	610	17315	784.3	1.000
3	1153	643	12576	265.2	3.428	1185	282	11116	343.7	1.587	1005	99	10341	311.6	1.000
4	1005	36	10005	643.2	3.525	1095	17	9758	668.0	1.731	958	3	7687	680.2	1.000
5	1035	387	9802	393.3	3.449	1007	30	9064	422.9	2.156	788	5	6664	394.0	1.000
6	583	30	5607	209.9	3.524	656	8	6655	223.1	1.789	426	2	3662	238.6	1.000
7	590	241	5957	224.2	3.309	494	10	4613	207.5	2.113	525	77	4894	257.3	1.000
8	1254	72	12790	388.7	3.567	1144	10	10580	446.2	1.525	1414	29	13825	523.2	1.000
9	814	338	7995	304.3	3.342	681	22	6109	333.7	2.004	735	208	6803	323.4	1.000
10	1103	55	9760	496.4	3.354	1126	38	8742	574.3	1.380	1027	12	8431	575.1	1.000
11	469	136	4608	211.1	2.984	740	242	7377	340.4	1.365	591	165	6214	301.4	1.000
12	1638	148	15330	540.5	3.534	1891	78	17709	605.1	1.629	1381	17	12035	580.0	1.000
13	1046	136	10204	428.9	3.558	1228	58	11543	442.1	1.548	963	18	8516	452.6	1.000
14	1702	336	15891	714.8	3.469	1838	28	16506	790.3	2.178	1826	8	16262	821.7	1.000
15	1127	384	10790	586.1	3.201	1008	777	8419	544.3	1.251	943	2	7779	641.3	1.000
16	1454	340	13779	654.3	3.426	1561	304	15266	702.5	1.502	1079	2	8500	604.3	1.000
17	631	158	6937	201.9	3.250	415	3	4277	203.4	1.921	695	130	6570	243.3	1.000
18	556	13	5072	233.5	3.573	571	4	4732	268.4	1.632	534	1	4611	235.0	1.000
19	1357	154	11190	773.5	3.520	1415	127	11511	750.0	1.514	1172	3	8565	843.8	1.000
20	1299	211	12769	428.7	3.546	816	76	6730	416.2	1.547	1425	12	13340	612.8	1.000
Average	1670.4	228.2	10325.5	438.8	3.378	1051.9	109.8	9470.5	470.4	1.694	1034.4	72.8	9292.8	502.9	1.000

a. Absolute value of residual
b. Terminal life history diversity index

Table 5. Summary of influence of selective and nonselective harvest at a fishing a fishing mortality of 0.65. Selective coefficients for life history types 1 through 5 are shown for populations that selectively harvested. Units of mean abundance, terminal abundance, catch and A.V.R are (x1000).

Environ. Regime	Summary (Fishing Mortality 0.65)														
	Nonselective					Selective 1 {5,5,3,1,1}					Selective 2 {1,3,5,3,1}				
	Mean Abundance	Terminal Abundanc	Catch	A.V.R	T.D.I	Mean Abundance	Terminal Abundance	Catch	A.V.R	T.D.I	Mean Abundance	Terminal Abundance	Catch	A.V.R	T.D.I
1	741	2	6891	437.2	3.415	755	1	6700	475.7	1.398	760	1	10362	471.2	1.000
2	720	12	6146	475.2	2.521	659	0	5004	474.5	1.977	876	26	7966	499.3	1.000
3	518	10	4715	222.7	3.418	638	4	6031	261.6	1.537	576	1	5206	241.9	1.000
4	763	0	6889	595.1	3.527	798	0	7191	590.5	1.654	786	0	6714	620.9	1.000
5	561	4	5173	353.4	3.451	665	0	6237	339.2	2.080	577	0	5152	346.2	1.000
6	309	0	2904	170.0	3.522	374	0	3605	153.3	1.730	289	0	2455	190.7	1.000
7	318	2	3289	181.3	3.287	296	0	2794	183.5	2.048	337	0	3364	195.5	1.000
8	669	1	6722	347.9	3.549	701	0	6749	357.5	1.488	717	1	7031	372.8	1.000
9	391	3	3522	262.0	3.318	407	0	3559	272.7	1.942	401	2	3487	256.6	1.000
10	817	0	6836	539.2	3.351	872	0	7061	531.9	1.350	835	0	6753	534.4	1.000
11	272	1	2565	146.9	2.952	346	3	3421	183.4	1.316	297	2	2821	157.4	1.000
12	1004	2	9477	532.1	3.528	1385	2	11298	497.7	1.563	949	0	8243	559.9	1.000
13	662	1	6442	403.8	3.554	816	1	8041	359.3	1.504	672	0	6279	409.9	1.000
14	1045	6	9620	595.7	3.463	1147	1	10459	630.9	2.112	1120	0	10120	627.2	1.000
15	669	4	5842	521.8	3.371	708	6	6174	502.7	1.216	643	0	5133	559.4	1.000
16	841	5	7292	580.3	3.420	876	6	7356	595.7	1.441	806	0	6491	580.3	1.000
17	115	1	2855	182.7	3.236	307	0	2578	202.6	1.852	344	1	3109	178.9	1.000
18	370	0	3087	233.1	3.574	380	0	3051	231.8	1.579	389	0	3178	229.5	1.000
19	965	1	7986	733.4	3.520	1026	1	8591	707.9	1.463	958	0	7344	795.1	1.000
20	677	3	6285	365.6	3.549	584	0	4645	379.6	1.494	759	0	7113	409.9	1.000
Average	611.4	2.9	5726.9	394.0	3.366	677.0	1.3	6027.3	396.6	1.637	654.6	1.7	5920.1	411.9	1.000

a. Absolute Value of the Residual
b. Terminal life history Diversity Index.

Figure 9. Relationships between environmental variation, population life history diversity and population abundance under nonselective harvesting and selective harvesting conditions with harvesting mortality, $F = 0.5$ (environmental regime 14).

A. Pattern of environmental variation for environmental regime 14. Brackets indicate range of environmental state over which each life history type can survive and reproduce. B. Changes in density of populations nonselectively and selectively harvested at $F = 0.5$. C. Change in the life history diversity index for nonselectively and selectively harvested stocks. D. Change in frequency of life history types composing nonselectively and selectively harvested stocks.

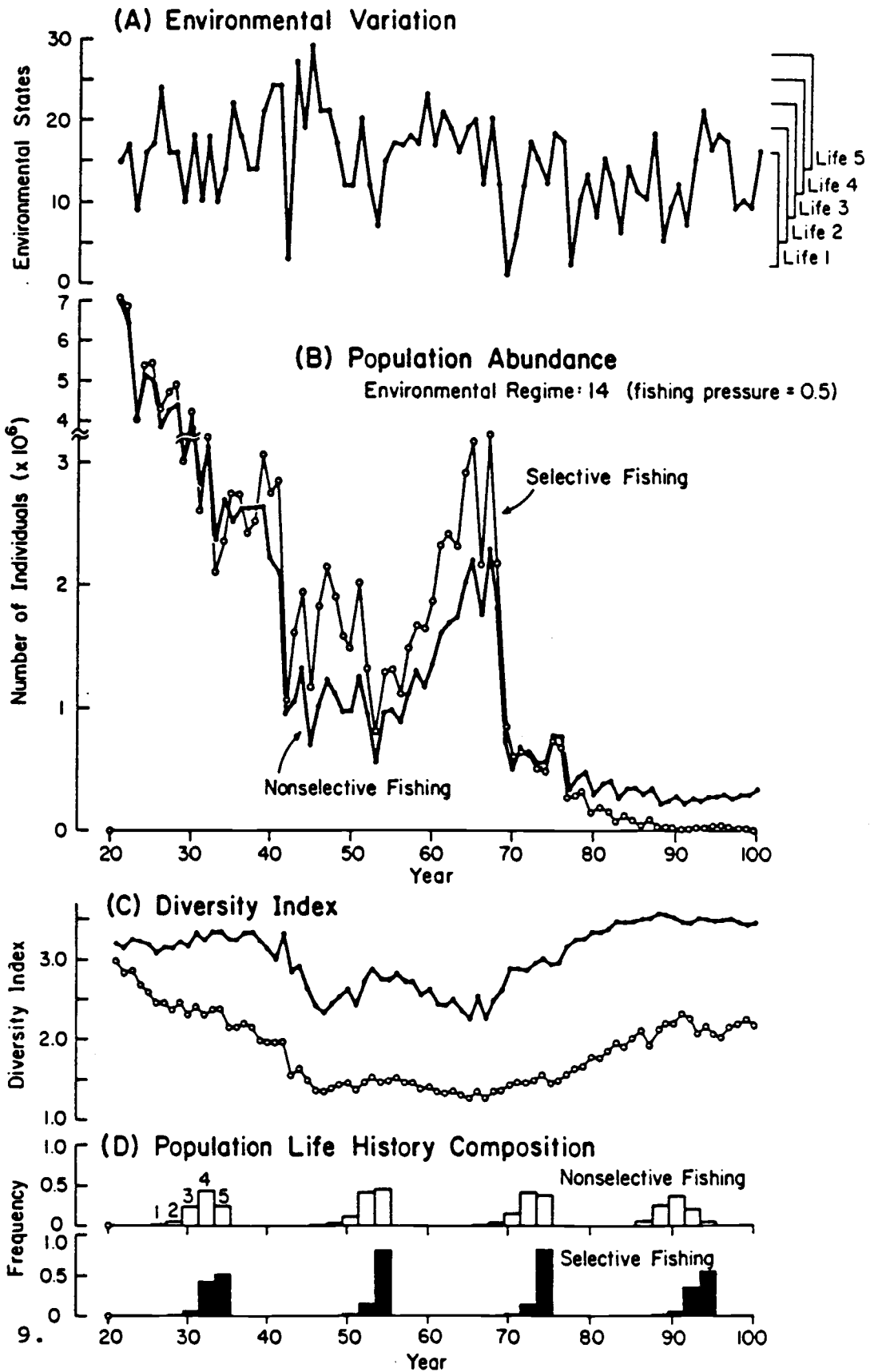

Figure 9.

decades, it became most suitable for life history types 1, 2 and 3.

Since nonselective harvesting removes individuals evenly from each life history type, population life history composition should not be influenced by harvesting effort. There is little difference in either the pattern of change of the diversity index or the life history distribution between nonselectively harvested (Fig. 9) and unharvested (Fig. 8) populations for environmental regime 14. However, population abundance severely declined as a consequence of harvesting. Once abundance has been depressed to a low level, very large increases in abundance cannot be expected, even though the population may encounter periods of suitable environmental conditions. Therefore, population abundance was maintained at a low level by such high harvesting pressure. The population still maintained its life history diversity and was able to persist.

Under selective harvesting, the life history types selectively harvested at a high rate, in this case types 1 and 2, have been completely eliminated, probably because of both selective harvest and the existence of environmental sequences less favorable for these types. Types 1 and 2 reappear at year 90, although at very low abundance, because environmental conditions most favorable for the persistence of these types begin to occur after about year 75. Life history type 4 which should be quite dominant throughout

much of the environmental sequence decreases because type 4 has gametes in common with type 2. Life history type 5 became dominant in the population, both because it was less intensively harvested than the other types and because the environmental sequence throughout the simulation was relatively favorable for type 5. These changes in life history composition resulted in a gradual decline of the diversity index to 1.3 (Fig. 9C, D). Under such circumstances, as the environmental sequence became highly favorable for life history type 5, the population exhibits a rapid increase in abundance such as occurred from year 43 to year 53 and from year 55 to year 65 (Fig. 9B). The environmental sequence shifted and remained in a range less favorable for types 4 and 5, but more favorable for types lost or reduced in abundance, such as life history types 1 and 2 at year 69, then types 4 and 5 decreased and this decrease was not compensated by increases in other life history types. As a result, population abundance drastically declined at year 69. For these kinds of reasons, variation in abundance, as measured by A.V.R, can be greater in populations in which life history diversity has been reduced.

Figure 9 illustrates the outcomes of selective and nonselective harvest under a single environmental regime. Tables 3 - 5 summarize results for all 20 environmental regimes.

At $F = 0.3$ and 0.5 , mean and terminal abundance are greater for nonselectively harvested populations than for those that were selectively harvested (Table 3 - 5).

Although mean abundance tended to be slightly greater in selectively harvested stocks at $F = 0.65$, the occurrence of extinctions was much greater under selective harvesting. At $F = 0.65$, nonselectively harvested stocks suffered four cases of extinction, while there were 11 cases in selective strategy 1 and 13 cases in selective strategy 2 (Table 5). Therefore, the capacity of the simulated populations to persist seems to be severely reduced by selective harvesting at $F = 0.65$. The average total catch for the 100 year periods show a similar trend, being greater in nonselectively harvested populations at $F = 0.3$ and 0.5 and somewhat less under nonselective harvesting at $F = 0.65$.

The terminal diversity index (T.D.I) of the nonselectively harvested stocks was not influenced by increased harvesting effort. T.D.I for nonselective harvest was much greater than for both selective harvesting strategies, indicating that selective harvesting severely reduced life history diversity. T.D.I for selective harvesting strategy 2 was barely above 1.0 at the lowest level of harvesting, $F = 0.3$. The great reduction of T.D.I may affect future population persistence and recovery. The A.V.R for nonselective harvesting are less than that of the selective harvesting strategies at all harvesting rates.

This indicates that population abundance tends to be more variable when populations are selectively harvested.

The above analysis is based on a general comparison of averages over 20 environmental regimes. However, at all harvesting rates, the outcomes of selective and nonselective harvesting are dependent upon the particular environmental regime being examined. For example, at $F = 0.3$, mean abundance and catch generally are greater for nonselective harvesting, but, under environmental regime 11, mean abundance and catch of the population harvested under selective strategy 1 exceeds the abundance and catch of the nonselectively harvested stock (Table 3). At $F = 0.65$ under environmental regime 2, under mean abundance, terminal abundance and total catch are greater for selective harvesting strategy 2 than for nonselective harvesting (Table 5).

At $F = 0.3$, in 16 out of 20 environmental regimes the mean abundance for nonselective harvesting is greater than that for selective harvesting. At $F = 0.5$, the number of environmental regimes in which mean abundance for selective harvesting is greater than that for nonselective harvesting is 12 for selective harvesting strategy 1 and 7 for strategy 2. At $F = 0.65$, mean abundance for selective harvest exceeds that for nonselective harvest in 16 environmental regimes under strategy 1 and 15 under strategy 2. Total catch shows a trend similar to that of mean abundance. The

number of regimes in which A.V.R is greater for selective harvesting than for nonselective decreases from 16 at $F = 0.3$ to 15 at $F = 0.5$ and to 10 at $F = 0.65$. Recall, however, that at $F = 0.65$ the number of extinctions is much greater for selective harvesting than for nonselective harvesting. In summary, at $F = 0.65$, overall differences in population performances between selective and nonselective harvesting tended to disappear, with the important exceptions of number of extinctions and T.D.I.

Population Recovery

For three environmental regimes (1, 11 and 14), following nonselective and selective harvesting ($F = 0.5$) for 100 years, fishing was terminated and population recovery was evaluated for 50 years in two different environmental sequences. Recovery environment 1 was chosen randomly by computer from the environmental frequency distribution. Recovery environment 2 had an environmental sequence favorable for life history types 1 and 2 for the first 25 years and was random thereafter.

In recovery environment 1, mean abundance, transitional abundance, terminal abundance and A.V.R are larger under nonselective than under selective harvesting conditions, indicating that nonselectively harvested stocks are able to recover more rapidly from intensive exploitation than selectively harvested populations. Selectively harvested

populations are able to recover their life history diversity, as indicated by T.D.I. Generally the same pattern prevails in recovery environment 2, except that terminal abundance at year 150 is nearly the same for both selective and nonselective harvest and T.D.I under selective harvest is substantially lower than nonselective.

Population recovery is contingent upon the life history structure at termination of harvest and the environmental sequence during recovery. Let us suppose that the environmental sequence during the recovery period (year 100 - 150) tends toward the range suitable for the population life history composition at year 100. The population will increase in abundance, yet may be far from recovering its life history diversity. Thus, the population may experience a rapid decline when environmental conditions unfavorable to the dominant life history types occur. The population will experience fluctuations in abundance of high magnitude and a high A.V.R value, such as occurred in recovery environment 2 for the populations originally exposed to environmental regimes 1 and 11. In these cases, the mean abundance and A.V.R for selective harvesting is larger than those for nonselective, but the terminal diversity indices were quite low, 1.734 and 1.655, respectively (Table 6). Second, suppose that the population must deal with a situation opposite to the first problem. That is, the environmental sequence during recovery tended to remain in a range

Table 6. Summary of populatio recovery following nonselective (N) and selective (S) harvesting ($f=0.5$) for 100 years in three environmental regimes, 1, 11 and 14. Units of mean abundance, transitional abundance, terminal abundance and A.V.R are (x1000).

Environ. Regime	Harvesting Strategy	Recovery Environmental Sequence 1					Recovery Environmental Sequence 2				
		Mean Abundance	Trans. ^a Abundance	Terminal ^b Abundance	A.V.R ^c	T.D.I ^d	Mean Abundance	Trans. ^a Abundance	Terminal ^b Abundance	A.V.R ^c	T.D.I ^d
1	S	3991	1277	9372	907.6	3.379	6139	2544	11998	1441.1	1.734
	N	5659	2913	12488	1018.5	3.421	6633	3571	12384	1227.7	3.031
11	S	4423	2578	9087	1149.9	3.338	7127	2843	11971	1781.6	1.655
	N	5565	3029	12210	1001.6	3.462	6865	3455	12351	1235.6	2.866
14	S	3389	766	11388	711.6	3.492	5565	3029	12210	1001.6	2.482
	N	6929	3139	12850	1316.4	3.261	7162	4421	12357	1074.3	3.293

- a. Transitional Abundance is abundance at year 125
b. Terminal Abundance at year 150.
c. Absolute Value of Residual.
d. Terminal Diversity Index.

Figure 10. Population recovery following nonselective and selective harvesting ($F=0.5$) for 100 years in environmental regime 14. A. Environmental variation for recovery environment 1. B. Changes in population density following termination of harvest at year 100. C. Changes in life history diversity following termination of harvest. D. Change in frequency of life history types composing the population following termination of harvest.

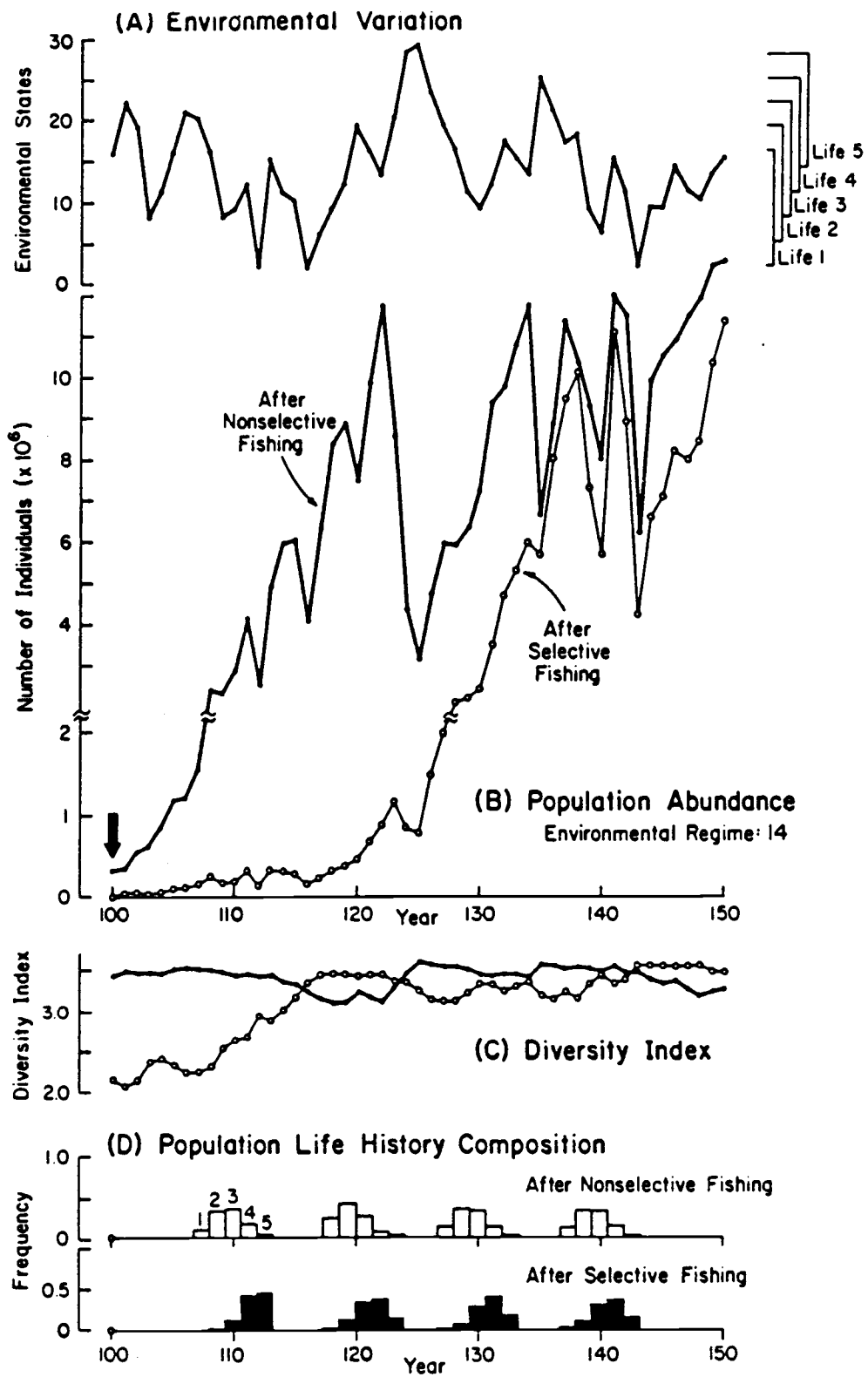

Figure 10.

unsuitable for the composition at year 100. In this case, recovery of population abundance was delayed, yet the life history diversity increases, such as occurred in recovery environment 1 for populations originally subjected to regimes 1 and 14. The mean and transitional abundance at year 125 are much lower for selectively harvested stocks than for nonselectively harvested populations, but the terminal diversity indices were almost the same.

This second case is illustrated in Figure 10. There are 3 different environmental sequences during the 50 year recovery period. The first period has conditions suitable for life history types 1 and 2 and occurs from year 105 to year 120. Over the second period, from year 25 to 30, the environment tends to be most suitable for types 4 and 5. From year 130 to 150, the conditions tend to be suitable for every life history type. At the termination of selective harvest, life history type 1 had disappeared from the population and type 2 was very low in abundance (Fig. 9). During the first environmental period, the selectively harvested population tends to recover its life history diversity (Fig. 10). Life history types 1 and 2 gradually reappear and the frequency of life history type 5 decreases, so that the diversity index increases to 3.4 (Fig. 10C, D). However, population abundance remains at a low level until year 126 (Fig. 10B). In contrast, the nonselectively harvested population recovered relatively quickly.

DISCUSSION

Populations must continuously adapt to changes in their environments. Figure 2B suggests that population evolution involves change in realized adaptive capacity, the particular performances that a population exhibits (eg. abundance, yield) at any time being determined by its realized capacity and environmental conditions at that time (Warren et al. 1979, Warren and Liss 1980). The way that a population evolves is determined by its potential adaptive capacity and evolutionary environment. Realized adaptive capacity is based upon population organization, which entails composition of life history types. Thus, in response to a changing environment, as the realized adaptive capacity of a population changes so does the life history composition. Population persistence, stability, and abundance are influenced by adaptive capacity and consequently life history composition.

In the simulated populations in this study, life history composition changed continuously in response to both harvesting effort and environmental change (Figs 8, 9 and 10). This change involved increases and decreases in abundance of types, disappearance of some types and their reappearance later in time (eg, under selective harvest in regime 14 at $F = 0.5$, types 1 and 2 disappeared at year 30 and reappeared at year 90). The reappearance of types is contingent on the population maintaining the

genetic (potential) capacity to produce the types, the reappearance of environmental conditions suitable for the types, and the maintenance of these suitable conditions for a long enough period of time for the types to become established. This work illustrates that the dynamics of stocks can be influenced considerably by their life history composition (Figs 8, 9 and 10, selective and nonselective at $F = 0.5$, recovery). This is especially evident when life history distribution tends to be highly skewed, as may occur as a result of selective harvest. This can lead to dramatic increases or decreases in abundance and yield, depending upon the pattern of change in the environment.

Since the frequency of life history types in a population at a particular time is correlated with past selective forces, a population well adapted to past environmental sequences sometimes may not be well adapted to present or future ones. Population life history composition can be readjusted to present conditions if life history diversity has been maintained (eg. from year 70 to year 100 in Figure 1B). Maintenance of a diversity of types may enable populations to better adapt to and so to persist in the face of environmental change.

Harvesting, habitat destruction, and other human activities can significantly influence population adaptive capacity (Murphy 1968, Schaeffer and Elson 1975, Warren and Liss 1980) and dynamics. Ricker (1981) suggested that

selective harvesting is a powerful evolutionary force in life history characteristics of Pacific salmon in Canada.

In general, selective harvesting of the simulated populations reduced mean and terminal abundance, total catch, and life history diversity. Nonselective harvesting tended to eliminate individuals evenly from the life history distribution so that the life history diversity was not greatly influenced. Selective harvesting tended to severely reduce or eliminate the life history types which were more intensively harvested. This generally resulted in extreme reduction of life history diversity. Variation in abundance, as measured by the absolute value of the residuals, was consistently larger in selectively harvested populations. Increased variation was probably related to reduction in life history diversity. Perhaps the most potentially alarming impact was the dramatic increase in incidences of extinction of selectively harvested populations at the highest exploitation rate. High selective harvest rate led to severe reduction in life history diversity which diminished the population's ability to persist in a changing environment. Furthermore, the extreme reduction of life history diversity made it difficult for populations that were able to persist to recover in abundance after termination of harvest.

It is important to note, however, that the above conclusions are general outcomes based on 20 different

environmental regimes. The results from a few individual regime were not in accordance with some of the general outcomes, illustrating simply that particular results are highly contingent on the particular environmental pattern.

Increased variation and reduced persistence resulting from loss of diversity are consistent with predictions of spreading of risk theory (den Boer 1968, Andrewartha and Birch 1984). This theory asserts that maintenance of diversity tends to buffer the influences of environmental change and stabilize abundance. Maintenance of diversity within the population adapts it to both spatial and temporal variation in its environment. From a management perspective, large increases in variation can result in lower predictability of stock abundance from year to year and create the need for significant yearly adjustments in fishing season lengths and total allowable catch. The uncertainty associated with this kind of situation is surely one of the causes of dissatisfaction among fishermen and contributes to fisheries management crises.

The model developed for this research assumes that the life history types composing a stock are adapted to somewhat different ranges of environmental conditions or habitats (Fig. 3). The existence of life history variation within populations is a necessary condition for evolution by natural selection (Lewontin 1970). In the view developed here, intrapopulation variation is assumed to adapt the

population to temporal and spatial variation in its environment. Fisheries biology has been more concerned with explanation of variation between stocks (eg. Iles and Sinclair 1982, Ricker 1972) than in attempting to understand the adaptive significance of variation within stocks. Gross (1984) argues that optimization theory forms the basis of most fish reproduction models. Indeed, it forms the basis of most of life history theory in ecology (Stearns 1976).

For example, Bell (1980) argues that the optimum age of maturity in females is the age at which the rate of increase in potential fecundity with increasing age is equal to or greater than the probability of mortality. Natural selection favors the life history type where female maturity occurs at that optimum age and selects against the types where female maturity occurs at an age other than the optimum age. Implicitly, all individuals that do not mature at the optimal age have lower fitness. Thus, natural selection tends to push the population toward the optimum life history type. This might be correct only if environmental conditions are constant. However, annual environmental conditions are not constant and the theory may not explain existing life history variation very well. Healey and Heard (1984) show that age at maturity and other characteristics of chinook salmon are not well explained by classical life history optimization theory. Both rate of increase in potential fecundity and rate of mortality for

each life history type may change with changing environmental conditions. Thus, the optimum age of maturity may change. The life history type that was optimal in some past environment may not be optimal in the present environment in fluctuating environments.

The theoretical work of Levins (1968) suggests that, for populations living in variable environments, selection should maintain variation in life history characteristics. In the model developed for the present research, life history performances of each life history type, modeled as l_x and m_x , change with changes in the environment. Birch (1948) showed that grain beetles have different l_x and m_x schedules when reared from birth under different conditions of temperature and moisture. It seems quite reasonable to assume that l_x and m_x will vary with changing environments for most species. In the model, different life history types have different optimal environmental conditions. In some sense there is no single optimum type, the different types being adapted to somewhat different sets of conditions. With the intensity of natural selection on each life history type varying both with changes in the environment and with changes in conditions of selective harvest, there must occur changes in life history composition within stocks.

Fisheries biologists have devoted relatively little effort either to documentation of life history variation

within populations, other than for statistical reasons, or to assessment of the adaptive basis of this variation. There are at least two reasons for this. Fisheries management has tended to focus principally on changes in abundance and yield from a purely mechanistic viewpoint. The adaptive consequences of harvesting and other human activities are just beginning to be considered (eg. Murphy 1968, Schaeffer and Elson 1975). When population adaptation perspectives are invoked, they are usually from either the point of view of classical life history optimality theory in which there exists a single optimum type, as Gross (1984) points out, or the point of view of protection of genetic diversity. Genetic diversity is of unquestionable importance in determining adaptive capacity. However, it is extremely difficult to assess and difficult to apply in management. Furthermore, the genes of a species are organized into stocks and life history types which are relatively more observable expressions of genetic organization and adaptive capacity.

Notable exceptions to the above statements are the work of Reimers (1971), Holtby and Healey (1986) and Gross (1984). Of particular relevance to the model developed here is the work of Holtby and Healey. They discuss a possible adaptive basis for variation in size at spawning of coho salmon in Carnation Creek. They argue that fish of different sizes are adapted to spawn in different kinds of

habitats within the stream. Larger fish tend to use spawning areas with larger gravel and swifter currents while smaller fish prefer areas with smaller gravel and slower current flow. Holtby and Healey argue that general hydrologic conditions within the stream vary from year to year and in some years eggs from nests of large fish will survive to hatching better than those from nests of smaller fish and in other years the opposite will prevail. Thus variation is maintained in the stocks and enables it to adapt to changing conditions of stream flow.

In general, traditional fisheries management has been based on assessment of population abundance and yield. Human activities such as harvesting, habitat modification from logging, building of dams and water extraction for irrigation and hatchery practices Lake tended to alter life history composition and diversity and may alter the adaptive capacities of populations and species. Effective management should protect the adaptive capacity of a population. One way to work toward this is to document life history variation and how it has changed, and to attempt to understand its adaptive significance. This is a necessary complement to the mechanistic numerical approaches normally adopted in fisheries management. The research reported here supports the view that protection of life history diversity is an important means of protecting adaptive capacity. The work also illustrates that the dynamics of stocks and their

persistence are related to life history composition and diversity. Thus it may be possible to maintain numerical properties of population such as abundance and yield through protection of adaptive capacity.

LITERATURE CITED

- Andrewarth, H. G. and L. C. Birch. 1984. The ecological web. University of Chicago press, Chicago, Illinois. 506pp.
- Beachan, T. D. and C. B. Murray. 1987. Adaptive variation in body size, age, morphology, egg size, and developmental biology of chum salmon (*Oncorhynchus Keta*) in British Columbia. *Can. J. Fish. Aquat. Sci.* 44: 244-261.
- Beverton and Holt 1957. On the dynamics of exploited fish population. U.K. Min. Agric Fish., Fish. Invest. (Ser. 2) 19: 533pp.
- Birch, L. C. 1948. The intrinsic rate of natural increase of an insect population. *J. Anim. Ecol.* 17: 15-26.
- Bell, G 1980 The cost of reproduction and their consequences. *Am. Nat* 116: 45-76.
- Cleveland, W. S. 1979. Robust locally weighted regression and smoothing scatterplots. *J. Am. Stat. Association* 74: 829-836.
- den Boer, P. J. 1968. Spreading of risk and stabilization of animal numbers. *Acta Biotheor.* 18: 165-194.
- Emlen, J. M. 1970. Age specificity and ecological theory *Ecology* 51: 588-601.
- Enright, J. T. 1976 Climate and population regulation *Oecologia* 24: 295-310.
- Gross, M. R. 1984. Sunfish, salmon, and the evolution of alternative reproductive strategies and tactics in fishes. In fish reproduction: strategies and tactics G. W. Potts and R. J. Wooton (eds) 55-75.
- Hankin, D. G. and R. McKelvey. 1985. Comment on Fecundity of chinook salmon and its relevance to life history theory. *Can. J. Fish. Aquat. Sci.* 42: 393-395.
- Healey, M. C. and W. R. Heard. 1984. Intev-and intra-population variation in the fecundity of chinook salmon (*Oncorhynchus tshawycha*) and its relevance to life history theory. *Can. J. Fish. Aquat. Sci.* 41: 476-483.

- Holtby, L. B. and M. C. Healey. 1986. Selection for adult size in female coho salmon (*Oncorhynchus kisutch*). *Can. J. Fish. Aquat. Sci.* 43: 1946-1959.
- Iles, T. D. and M. Spinclair. 1982. Atlantic herring: stock discreteness and abundance. *Science* 215: 627-633.
- Larkin, P. A. 1977. An epitaph for the Concept of maximum sustained yield. *Trans. Am. Fish. Soci.* 106: 1-11.
- Levins, R. 1968. Evolution in changing environments. Princeton University press, Princeton, New Jersey. 120pp.
- Lewontin, R. E. 1970. The units of selection. *Ann. Rev. Ecol. System* 1: 1-18.
- Murphy, G. I. 1968. Pattern in life history and the environment: *Am. Nat.* 102: 391-403.
- Pepper, S. C. 1942. World Hypothesis. University of California Press, Berkeley.
- Reimers, P. E. 1971. The length of the residence of juvenile fall chinook salmon in Sixes River. *Oregon. Fish. Comm. Oregon Res. Briefs*: 99pp.
- Ricker, W. E. 1954. Stock and recruitment. *J. Fish. Res. Board. Can.* 11: 559-623.
- _____ 1972. Hereditary and environmental factors affecting certain salmonid population. In the stock concept in Pacific salmon, H. R. MacMillan Lecture in Fisheries, R. C. Simon and P. A. Larkin (eds) University of British Columbia. 19-160
- _____ 1975. Computation and interpretation of biological statistics of fish population. *Bull. Fish. Res. Board. Can.*
- _____ 1981. Changes in the average size and average age of the Pacific salmon. *Can. J. Aquat. Sci.*
- Schaefer, M. B. 1954. Some aspects of the dynamics of populations important to the management of the commercial fish population. *Bull Inter-Amer. Trop. Tuna Comm.* 1: 27-56.
- Schaeffer, W. E. and P. F. Elson. 1975. The adaptive significance of variations in life history among local populations of Atlantic salmon in North America. *Ecology* 56: 577-590.

- _____ 1979. The theory of life-history evolution and its application to Atlantic salmon. Symp. 2001. 50C. Loud 44: 307-326.
- Simpson, E. H. 1949. Measurement of diversity. Nature 163: 688.
- Spangler, G. R., N. R. Payne and G. K. Winterton. 1977. Percids in the Canadian waters of Lake Huron. J. Fish. Res. Board Can. 34: 1839-1848.
- Stearn, S. C. 1976. Life-History tactics: a review of the idea. Quart. Rev. Biol. 51: 3-47.
- Tompson, W. F. 1962. The relationship between numbers spawning and numbers returning in Pacific salmon. In symposium of pink salmon, H. R. MacMillan Lecture in Fisheries, N. J. Wilimousky (ed) University of British Columbia 213-225.
- Warren, C. E. and W. J. Liss. 1980. Adaptation to aquatic environments. In fisheries management, R. L. Lackey and L. Nielsen (eds). Blackwell Scientific Pub., Oxford: 15-40.