

AN ABSTRACT OF THE THESIS OF

Thomas L. Nordblom for the degree of Doctor of Philosophy

Agricultural and
in Resource Economics presented on August 20, 1981

Title: Simulation of Cattle Cycle Demography: Cohort Analysis of
Recruitment and Culling Decisions in the National Beef Cow Herd.

Abstract approved :

Redacted for Privacy

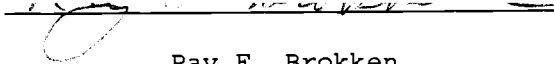
Ray F. Brokken

This study expresses the hypothesis that historical patterns of national beef cow herd accumulation and liquidations (the cattle cycle) have been related to investment incentive differences across cow ages through time, resulting each year in changes in herd age structure, performance and potentials for adjustment in subsequent years.

A review of national cattle cycle literature reveals the common assumption of variable heifer recruitment levels through time to the mature cow herd. A review of firm level cattle cycle strategy studies shows that most which considered heterogeneous herds (distinguishing performance by cow age) ironically assumed constant recruitment in proportion to cow numbers.

Farmer interviews indicated that heifer recruitment may vary widely in proportion to cow numbers from year to year and that there are strong tendencies to cull non-pregnant and unsound cows from the herd at any age. The present study assumes both variable recruitment and age heterogeneity.

A search and synthesis of the biological literature allowed

expression of economically important attributes as point estimates from continuous functions of cow age. These attributes are conception rates, health rates, cow survival rates, cull cow body weights, calf survival rates and weaning weights. Based on these biological parameters, and on the assumption that non-pregnant and unsound cows would be culled, retainment and culling rates are defined as management expectation parameters. These biological and expectation parameters are the building blocks of a simulation model designed to make value comparisons between cows of different ages and pregnancy status and to trace out changes in the national cow herd age structure through time.

A budget generator produces estimates of expected net annual revenues for each of the 26 discrete age and pregnancy classes of heifers and cows, in each year from 1950 through 1978, based on exogenous price and cost series. These estimates are used to project the present values of expected future net revenues for each class of breeding animals. The ratio of future breeding value to present cull slaughter value is calculated for each of the 26 classes, each year. These V-ratios, in turn, are decision variables for determining the proportions of animals in each class to be retained in the herd, simulated by a national beef cow demography model.

Annual summations from the demography model are compared with objective historical series of January 1 inventories of beef cows and replacement heifers, and annual numbers of cull cows slaughtered and beef calves born. The model's simplicity, ignoring related livestock sectors, is one of its significant features. With its few exogenous price and cost variables, simple biological relationships and manage-

ment assumptions, the model is able to track the historical numbers of beef cows and calves born quite well.

Mean proportional absolute deviations (MPAD) of the simulated series from the objective historical series were computed in addition to simple correlation coefficients and Theil's coefficients of inequality. In a display run, the tracking behavior of the model was best for cow inventories and calves born, and worst for heifer recruitment and cull cows, with MPAD's of .029, .036, .172, and .261, respectively. Theil's coefficients of inequality were .405, .587, .962, and .842, respectively.

In an alternative run, with parameters set to reflect the assumption that all cows have the same performance characteristics across ages, the tracking behavior of the model was in several aspects about as good as the display run. Thus, the null hypothesis that performance differences across cow ages are of no importance in explaining investment behavior could not be rejected.

Simulated national beef cow herd age structure changes through cattle cycles are shown from 1950 through 1978.

© Copyright by Thomas Lee Nordblom
August 20, 1981
All Rights Reserved

SIMULATION OF CATTLE CYCLE DEMOGRAPHY:
COHORT ANALYSIS OF RECRUITMENT AND CULLING DECISIONS
IN THE NATIONAL BEEF COW HERD

by
Thomas Lee Nordblom

A THESIS
submitted to
Oregon State University

in partial fulfillment of
the requirements for the
degree of

Doctor of Philosophy

Completed August 20, 1981
Commencement June 1982

APPROVED:

Redacted for Privacy

Professor of Agricultural and Resource Economics in charge of major

Redacted for Privacy

Head of Agricultural and Resource Economics

Redacted for Privacy

Dean of Graduate School

Date thesis is presented August 20, 1981

Typed by Carol Blake, Rebecca Lent and Helen Thaler

for: Thomas Lee Nordblom

ACKNOWLEDGEMENTS

This thesis is dedicated to the memory of the author's father, Donald R. Nordblom, whose constant encouragement and moral example have helped immeasurably.

The Department of Agricultural and Resource Economics, at Oregon State University, has provided office space for which the author is grateful. Dr. Ray Brokken, E.R.S., U.S.D.A., acted as major professor and arranged funding for the computing requirements of this study, typing of the appendices and some support for the author. Without additional financial and moral support of several friends, the author could not have persevered to complete this thesis. The author's debts to these people are honored private obligations.

Dr. Ray Brokken's contribution to this work has been pervasive, his helpful suggestions too numerous to mention individually. The author is very grateful for his guidance. The thoughtful criticism by Dr. Stanley Miller at various stages of the simulation modeling process, and in review of chapters 2, 3, and 4, has also been very helpful. Dr. Richard Johnston and Dr. Joe Stevens provided useful comments on the final draft. Dr. W.S. Overton encouraged the use of the FLEXFORM model documentation as a means of communication and to facilitate criticism.

Curtis White made many valuable suggestions on model structure and assisted with implementation of two versions of the model for FLEX 4 processing in FORTRAN IV on the O.S.U. Cyber computer. He also assisted in preparation of the bibliography. Russ Crenshaw gave timely help in coding necessary structural changes in the model for

computer processing. Dan Hardesty and Andy Lau wrote plotting programs used to create all figures in this thesis.

Gordon Cook and Martin Zimmerman identified farmers with cow/calf operations in Sherman, Gilliam and Wasco counties in north-central Oregon. The author is especially grateful for the cooperation granted by these farmers in allowing time for intensive interviews. By drawing attention to errors and oversimplifications in the author's questions, these people positively influenced the focus of this study.

Cathy Robinson assisted in transcription of tape recorded farmer interviews, in preparation of the bibliography and typing of the chronological summary literature reviews. Rebecca Lent painstakingly corrected and typed the first draft of the text and the final draft of chapter 5. The author acknowledges a great debt of kindness to her. Helen Thaler handled the difficult typing of appendices A and B (the FLEXFORM and Statistical Formulae). Carol Blake typed the remainder of the final text draft.

The author is very grateful for the assistance of those mentioned above. Naturally, the responsibility for any errors or omissions in this study are his alone.

TABLE OF CONTENTS

<u>Chapter</u>	<u>Page</u>
1. INTRODUCTION	1
The Enigma of the Cattle Cycle	1
National Cattle Cycle Literature	3
Firm Level Cattle Cycle Strategies	15
Thesis Objectives	22
Methodology	23
Synthesis	24
Demography	25
Cattle Simulation Models	27
FLEX	29
Plan of the Thesis	30
2. BIOLOGICAL AND MANAGEMENT EXPECTATION PARAMETERS	33
Introduction	33
Conception Rates by Cow Age	34
Unimpaired Health Rates by Cow Age	42
Survival Rates by Cow Age	48
Cow Weight by Cow Age	50
Calf Weaning Weights by Cow Age	58
Cow Age and Calf Survival From Conception to Weaning	65
Management Expectation Parameters	71
Expected Retainment Rates	73
Expected Fractional Culling Rates	78
3. DRIVING VARIABLES: PRICE AND COST SERIES	81
Calf and Cull Cow Prices	82
A Cull Cow Price Function	86
Beef Breeding Animal Maintenance Cost Budgets	89
Feed Costs	91
Husbandry Costs	96
Common Costs	99
Historical Input Cost Series	101
Pasture Rental	102
Hay	103
Grain, Concentrate and Silage	104
Salt and Minerals	104
Labor	105
Medicine and Veterinary Care	105

TABLE OF CONTENTS (cont.)

<u>Chapter</u>	<u>Page</u>
(Chapter 3, cont.)	
Marketing and Handling	106
Fuel, Lubrication and Electricity	106
Machinery and Building Repairs	106
Bull Depreciation Charges	107
Interest Rates	107
Driving Variable Summary	108
4. THE BEEF COW VALUE AND DEMOGRAPHY MODEL	110
The Beef Cow Value Model	111
Future and Present Cull Salvage Value	113
Annual Cost Budget Generator	115
Expected Net Annual Revenues	120
Present Value of Expected Net Future Incomes	123
Decision Variables	131
Synopsis of the Value Model	134
Beef Cow Demography Model	135
State Variables	138
Retention Decisions	143
Numbers Retained and Culled	147
FLUX Functions	154
5. VALIDATION, RESULTS AND CONCLUSIONS	157
Historical Data	157
Statistical Comparison of Simulated and Historical Data	158
A Display Simulation	166
Relative Cow Value Shifts	170
Age Structure: Demographic Pulse	172
Conclusions	176
Indications for Future Research	178
BIBLIOGRAPHY	179
APPENDIX A: FLEXFORM	196
State Variables	200
Annual Variable Inputs	201
Memory Variables	202
Intermediate Functions	210
FLUX Functions	241
Output Functions	242
Parameter List	257
APPENDIX B: STATISTICAL FORMULAE	268
APPENDIX C: SOURCE FILE CODE	271

LIST OF FIGURES

<u>NO.</u>	<u>TITLE</u>	<u>PAGE</u>
1.1	Cow Inventories in the United States, 1929-1979	2
1.2	Simulated Cyclic Changes in Cow Herd Age Structure: Demographic Pulse	19
2.1	Conception Rate Estimates by Cow Age	39
2.2	Unimpaired Health Rates ($g_{2,j}$)	47
2.3	Data on Cow Body Weight by Cow Age	52
2.4	Early and Late Maturing Cow Body Weight Patterns	55
2.5	Calf Weaning Weight by Cow Age	61
2.6	Calf Survival Rates ($g_{8,j}$)	70
2.7	Expected Retainment Rates ($g_{9,j}$)	77
2.8	Expected Fractional Culling Rates by Cow Age ($g_{10,j}$)	80
3.1	Cull Cow Price Estimates by Cow Age	88
4.1	Beef Cow Demography Flowchart	137
4.2	Retainment Decision Function ($g_{37,j}$)	145
5.1	Simulated and Historical Numbers: Display Run	168
5.2	Optimistic and Pessimistic Relative Cow Values	171
5.3	Simulated Cumulative Age Structure of the U.S. Beef Cow Herd, 1950 - 1978	173
5.4	Simulated Percentage Age Composition of the U.S. Beef Cow Herd, 1950 - 1978, with Recruitment-Year Cohorts	175

LIST OF TABLES

NO.	TITLE	PAGE
1.1	Chronology of National Cattle Cycle Literature	4
1.2	Chronology of Firm Level Cattle Cycle Strategy Literature . . .	17
2.1	Parameters of Conception Rate Function Fits to Earlier Study Data	41
2.2	Cow Weight Proportions by Cow Age for Early and Late Maturing Breeds	54
2.3	Calculation of Calf Weaning Weight Indices by Cow Age	60
2.4	Calf Loss Data by Cow Age	68
2.5	Estimation of Calf Survival Function	69
3.1	Feed Cost Allocation Factor	93
3.2	Decomposition of Herd Feed Costs, Great Plains, 1978	94
3.3	Feed Costs per Head, Base Year Budget Parameters, Great Plains, 1978	95
3.4	Husbandry Costs, Base Year Budget Parameters, Great Plains, 1978	98
3.5	Common Costs, Base Year Budget Parameters, Great Plains, 1978.	100
3.6	Simulation Model Driving Variables	109
4.1	Value Model Function List.	112
4.2	Demography Model Function List	136
5.1	Comparison Statistics for Simulated and Historical Numbers. . .	167

SIMULATION OF CATTLE CYCLE DEMOGRAPHY: COHORT ANALYSIS OF
RECRUITMENT AND CULLING DECISIONS IN THE NATIONAL BEEF COW HERD

CHAPTER 1

INTRODUCTION

The Enigma of the Cattle Cycle

The historical cycles of cattle numbers and prices in the U.S. and other countries have been as regular and damaging as they have been mysterious. The damages are in the form of systematic misallocations of resources. These include periodic over-investment in beef cow inventories followed by liquidation, under bankruptcy conditions, to inventory levels below those which might be maintained in stable equilibrium.

Figure 1.1 illustrates the extraordinary regularity of cow inventory cycles in the U.S. The January 1 inventories of dairy and beef cows and their total numbers are indicated. Over the 50 year period shown, there has been considerable specialization in cattle types, most spectacularly in dairy cows. While the dairy cow inventory of 1979 was about half that of 1949, total milk production was greater in 1979 than in 1949. Dairy calves, especially the males, contribute to veal and beef production. Essentially, all veal calves slaughtered are of dairy origin, though many dairy calves are raised as beef cattle for slaughter at heavier weights.

Figure 1.1 shows a dramatic upward secular trend in beef cow numbers, which occurred in great steps of roughly 30 percent at about 10 year intervals. These beef cow inventory cycles, and their demographic

Figure 1.1 COW INVENTORIES IN THE UNITED STATES, 1929-1979 a/

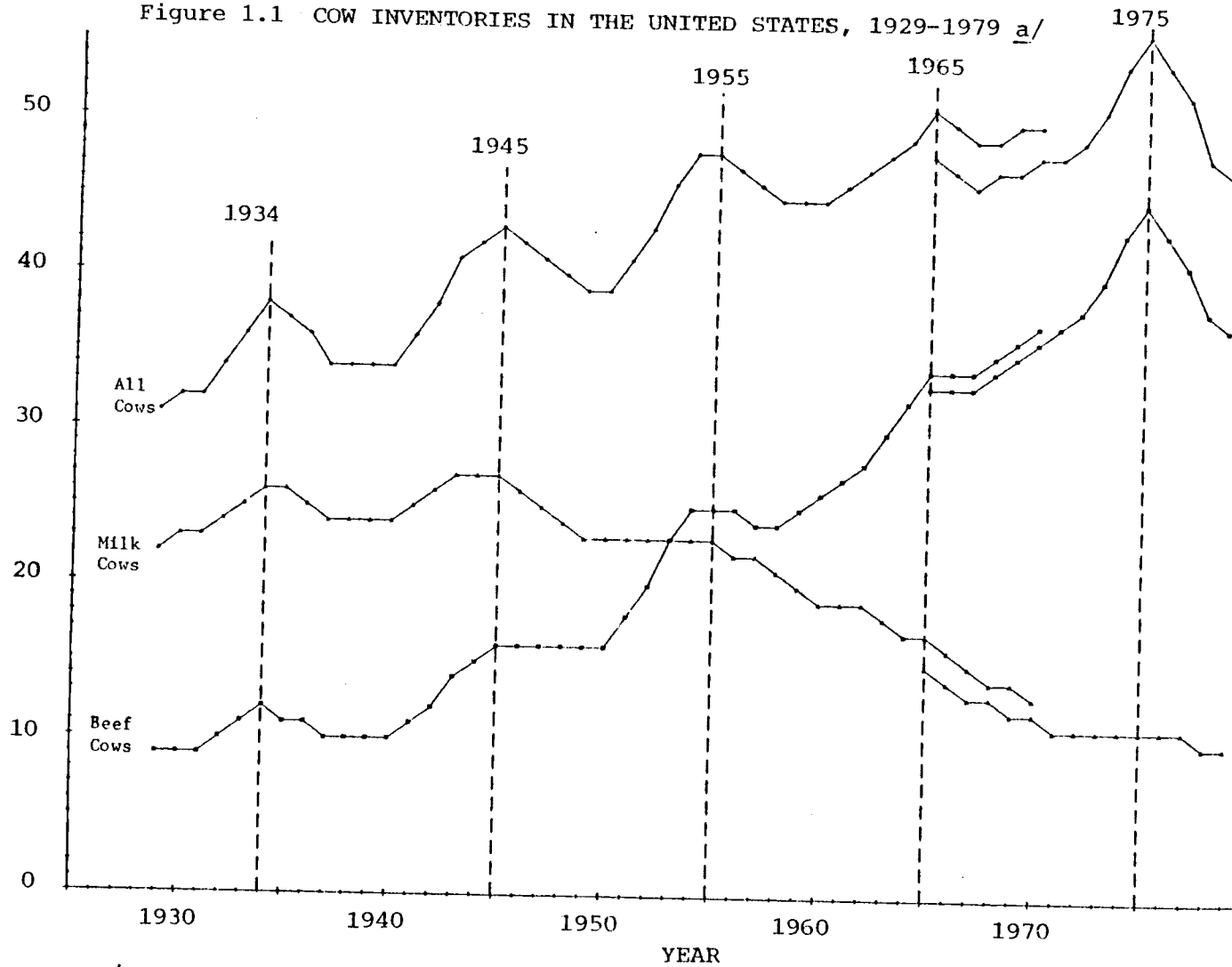

a/ reported until 1970 as cows and heifers 2 years old and over; but, since 1965 reported as cows and heifers that have calved. Source: U.S.D.A.

anatomy, are the focus of this study. A brief review of the cattle cycle literature is given as background for a more precise statement of the thesis objectives and methodology.

National Cattle Cycle Literature

A considerable body of literature has evolved in the sustained concern over the nature and the causes of the cattle cycle. A chronological summary review of national cattle cycle literature is given in Table 1.1. This briefly annotated chronology is by no means a complete list, but is representative of past work on the subject. The review in Table 1.1 illustrates the recent proliferation of studies which deal with the cattle cycle, a sign of sustained and growing interest in this chronic ailment of the beef industry.

The studies which stand out as major works on the subject are Hopkins (1926), Lorie (1947), DeGraff (1960) and Ehrich (1966). Hopkins considered the cyclical buildups and liquidations of cattle numbers and associated prices from the late 1800's to the mid 1920's, attempting to explain them in terms of various exogenous forces. These included large changes in the amount of grazing land available, changes in animal husbandry methods, wars and other factors (such as the business cycle) causing sudden changes in the costs of beef production or in the demand for beef (1926, p. 339).

Twenty-one years later, with the benefit of having observed an additional two cyclic peaks in cattle numbers, in 1934 and 1945, Lorie (1947, pp. 50-51) labeled Hopkins "the leading exponent of the theory of exogenous causation," and proceeded point by point to discount those explana-

TABLE 1.1 CHRONOLOGY OF NATIONAL CATTLE CYCLE LITERATURE

- Hopkins (1926): the first major study of the cattle cycle: inventories, flows and prices: attributed chiefly to exogenous causes
- Voorhies and Koughan (1928): noted a cycle of 14 to 16 years in U.S. cattle numbers, in a study focusing on the California beef industry
- Hultz (1930): graphical exposition of cattle price and production cycles (1867-1925)
- Potter (1930): asserted that there have always been long periodical fluctuations in the supply and price of beef cattle
- Ezekiel (1938): cycles in cattle prices and numbers implied to be a demonstration of the cobweb theorem
- Schumpeter (1939): Kitchin and Juglar cycles, acting through consumer expenditures, asserted to be at the roots of hog and cattle cycles
- Goodwin (1947): the role of producer price expectations in cyclical behavior
- Lorie (1947): the seminal study of the cattle cycle: statistical and theoretical review and exposition
- Burmeister (1949): review of regional differences in cyclical patterns of cattle numbers
- Breimyer (1955): review of cattle cycle literature: national cattle number balance sheets and inventory compositions through time
- Ensminger, et al (1955): detailed survey of problems and practices of cattlemen in 24 states, noted that 17.8 percent of beef cows were culled in 1954
- Wallace and Judge (1958): econometric analysis of the beef and pork sectors, recognized differences in culling pressure across cow ages through cattle cycles
- DeGraff (1960): a landmark study of the cattle cycle, focusing on marketing questions
- Fuller and Ladd (1961): dynamic quarterly model of the beef and pork economy (1949-1960)

TABLE 1.1 CHRONOLOGY OF NATIONAL CATTLE CYCLE LITERATURE (cont.)

- Oppenheimer (1961): anecdotal account associating one or two year downswings with distress liquidations due to widespread drought
- Maki (1962): decomposition of beef and pork cycles: recursive chain of market and production variables
- Larson (1964): the hog cycle as harmonic motion: suggested that the same technique may be applied to the cattle cycle
- Marshall (1964): trends, cycles and seasonal variations in Canadian cattle inventories and marketing
- Waugh (1964): long production lags for cattle mentioned in cobweb model context
- Wilson (1964): lists 11 citations alleging cattle production cycles, and 24 alleging rhythmic cattle price cycles
- Williams and Stout (1964): cobweb cattle cycle review, noting that inventory composition changes affect production cycles and that heifers have a principle role in these changes
- Crom and Maki (1965): dynamic model of a simulated livestock-meat economy
- Egbert and Reutlinger (1965): dynamic long-run model of the livestock-feed sector
- Nordquist and Ottoson (1965): extension circular: popular language review of cattle cycle history
- Walters (1965): single equation prediction models for beef inventory classes (1947-1964)
- Bray (1966): beef productivity increases in the Southeastern states of the U.S., showing pronounced inventory cycles
- Ehrich (1966): harmonic motion model of cycle generation in the U.S. beef economy
- Reutlinger (1966): short-run beef supply response model (1947-1962)
- Trierweiler and Erickson (1966): extension article: popular language interpretation of a cow/calf sector model (1950-1963)
- Uvacek (1966): focus on cattle feeding in Texas in context of U.S. cattle cycle

TABLE 1.1 CHRONOLOGY OF NATIONAL CATTLE CYCLE LITERATURE (cont.)

- Gray (1968): idealized cattle cycle phases defined in textbook format
- Gruber and Heady (1968): a large econometric study correlating price and inventory series (1925-1962), employing "upswing" and "downswing" dummy variables
- Uvacek (1968 and 1969): postulated abrupt shifts in beef demand for buildup and liquidation phases
- Folwell (1969): questioned Uvacek's demand shift tests
- Crom (1970): dynamic price-output model of the beef and pork sectors
- Kim (1970): U.S. beef cow inventory (total) model (1931-1964)
- Franzmann (1971): sine curve fitted to deflated 1921-1969 series of average U.S. cattle slaughter prices: called for cyclical low prices in 1974
- Franzmann and Walker (1972): 10 year cattle price cycle assumed in short-run trend models
- Kulshreshtha and Wilson (1972): econometric model of Canadian beef sector: demand, supply, price, and export variables (1949-1969)
- McCoy (1972): review of U.S. cattle cycle (1896-1972) in textbook format
- Paulsen, et al (1973): quarterly model of beef, pork, sheep, broiler and turkey sectors: projected beef cow inventories 5 years into future (to 1978)
- Ehrich and Usman (1974): demand and supply functions for beef imports
- Jarvis (1974): econometric analysis of the Argentine cattle sector (1937-1967)
- Kulshreshtha and Wilson (1974): spectral analysis: 10 year cycle in Canadian cattle slaughter
- Tryfos (1974): Canadian supply functions for livestock and meat (1951-1971)
- Elam (1975): questions positive price coefficients found by Tryfos for cattle inventories

TABLE 1.1 CHRONOLOGY OF NATIONAL CATTLE CYCLE LITERATURE (cont.)

- Freebairn and Rausser (1975): associated higher beef import levels with small increases in the number of beef cows in simultaneous equation model
- Shirk (1975): graphical analysis of U.S. cattle number cycle (1870-1975)
- Keith and Purcell (March and August 1976): a quarterly model of beef slaughter (1949-1974) which "failed to identify the exact set of circumstances necessary to precipitate a general liquidation of cow numbers," with the assertion that improved cow slaughter data is the "key to the cycle"
- Choi (1977): spectral analysis: 7 year cattle cycle of "surprising regularity" in West Germany
- Folwell and Shapouri (1977): econometric analysis of the U.S. beef sector (1949-1973)
- Ginn (1977): study of grain prices and beef feeding: slaughter composition (1965-1977)
- Jacobs (1977, 1978, and 1979): popular language explanations of the national cattle cycle process and firm level decisions, especially with regard to backgrounding
- Drovers Journal (1978): panel discussion on solutions to the cattle cycle
- Everett and Vickery (1978): periodic droughts in South Australia in relation to cattle and horse populations (1886-1975)
- Hinchy (1978): spectral analysis: Australian beef and the U.S. cattle cycle
- Ospina and Shumway (1978): annual beef supply response model (1956-1975) showing positive short-run supply elasticity
- Pope (1978): suggested that tomorrow's beef producer may have to "surrender certain key decisions to larger organizational structures" to merchandize his output more efficiently than during the disastrous mid-1970's liquidation
- Cattle Fax (1978): national production accounts focusing on cow inventory per 100 people
- Doran, Low and Kemp (1978): cattle as a store of wealth in Swaziland; cyclical patterns shown

TABLE 1.1 CHRONOLOGY OF NATIONAL CATTLE CYCLE LITERATURE (cont.)

- Hertzler and Cothorn (1979): control theory analysis; showing that the beef cycle is sub-optimal
- Martin and Meilke (1979): model of U.S. feed-grain, beef and pork sectors (1969-1977)
- Matsuda (1979): spectral analysis: 7 year cycles in wholesale prices and quantities of beef in Japan (1960-1977)
- Minish and Fox (1979): brief discussion of the cattle cycle in animal husbandry text
- Riley (1979): speech lamenting our lack of understanding of the cattle cycle
- Valdes and Franklin (1979): 6 to 8 year cattle price cycle shown in Colombia
- Farmbank Research and Information Service (1980): projections of cattle numbers and prices to 1987
- Gustafson, Remele and Shaw (1980): calculated that the "value" of the national herd more than doubled from Jan. 1, 1978 to Jan. 1, 1980, although total inventory of cattle and calves fell
- Minsky and Shellenberger (1980): popular article on the cattle cycle process: producer and consumer responses
- Reeves (1980): U.S. and Australian beef trade, institutional constraints and price stabilization.....catastrophe theory applied to the cattle cycle
- Yanagida and Conway (1980): annual livestock model of the U.S.: investment demand as function of herd size and lagged profitability
- Conable (1980): changes in U.S. meat import law in 1979 to include a "countercyclical" factor in the formula for annual quota establishment

tions. Lorie then turned (pp. 51-53) to attack Ezekiel's (1938) assertion that the "cobweb theorem" provides an adequate explanation of the cattle cycle.

While Lorie's model of the cattle cycle could be classed with the cobweb theorem as belonging to a school of endogenous causation hypotheses, it made some important distinctions. These involved separating the notions of production and marketing, and discerning their effects on prices and the responses of producers.

Lorie aimed to define the interrelationships among value, marketing and numbers of cattle on inventory. The term "value" was defined as the market price of cattle per unit of weight multiplied by the weight per head or, alternately, the weight of all cattle on inventory. The same meaning is intended in the concept of "purchasing power of cattle." The distortions which arise in appraising the value of the entire breeding herd inventory at prices determined in the marginal slaughter market have a central role in Lorie's model.

Lorie (p. 53) discussed the reaction of beef cow owners to a general rise in slaughter prices. He said that American farmers have characteristically reacted by increasing their herd sizes at the expense of decreased current marketings in order to increase production in the future. The decrease in current marketings would, ceteris paribus, cause a rise in slaughter prices, reinforcing the original incentives to increase the size of the breeding herd.

Lorie (p. 54) suggested the existence of a "normal" price, above which farmers would tend to increase their herd size, and below which they would tend to liquidate part of their breeding herds. On a farm by

farm basis, this "normal" price may differ with local costs but might be considered as the price level at which all cut-of-pocket costs would be covered by the sale of steer calves, non-pregnant or unsound cows, and about 75 percent of the heifer calves.

As the heifer calves, which are withheld from the slaughter stream over several years, mature and contribute their own offspring to the total weaned calf crop, and ultimately to the slaughter market, the self-reinforcing increases in prices and inventories cease. As slaughter prices fall below the "normal" level, herd growth would stop as liquidation of breeding animals begins. The liquidation of cows on the slaughter market in addition to a large number of younger slaughter animals may be reflected in plummeting slaughter prices.

As liquidation of the breeding herd painfully proceeds to flood the slaughter market the total productive capacity of the market falls; in gross terms, fewer cows will wean less calves. Eventually, current marketings reach a maximum level and slaughter prices, a minimum. With reduced herd size, and reduced marketings, prices begin to rise. As slaughter prices rise, but remain below the "normal" level at which breeding herd variable costs would be covered, herd liquidation may continue.

Herd building (accumulation) begins again as slaughter prices rise enough to allow fewer calf sales to cover the herd's variable costs. This brings Lorie's (1947) account of the cattle cycle process back to its beginning. He recognized the limits of this ceteris paribus; explanation, allowing for some of the exogenous influences mentioned above. The regular, successive herd accumulations and liquidations which Lorie

traced from 1890 to the mid 1940's have continued quite regularly to the present.

The decision process behind the "reaction" of farmers to increase or decrease their breeding herd inventories was not defined by Lorie other than in terms of general tendencies. He suggested that the increments to herd size will be greatest when market prices are at their peak, and that decrements will be greatest when market prices have reached their minimum (p. 57).

Lorie's (1949) study has endured as the foundation of our understanding of the cattle cycle process. Writers since then have paraphrased Lorie quite shamelessly, often with only vague reference to their source. What is most surprising is that our received knowledge of the cattle cycle has expanded since 1947 little more than in terms of our observations on its vigorous continuation. The explanations of the process offered in the current literature have not advanced much beyond those of 1947.

The American National Cattlemens Association must be credited for initiating and supporting important studies of the beef industry. For example, Ensminger, et al., (1955) conducted a questionnaire study of the practices and problems of cattlemen in 24 states. The purpose stated for that study was to document the locations and natures of the industry's problems to facilitate the acquisition of research funds. The national beef cow inventory had expanded to its greatest size in history over the 6-year period immediately preceding the survey, and slaughter prices had begun to fall only the year before, yet no mention of these points was made. Concerned mostly with disease frequencies, feeding practices and

other aspects of animal husbandry, the survey included only a few questions about marketing methods and sources of market information. The cattle cycle was hardly what cattlemen would have wanted to contemplate.

A year following publication of the survey of the beef industry's problems, the abysmal cattle prices of 1956 accompanied a significant liquidation of beef cow inventories. By 1957, the American National Cattlemens Association had organized a major study of the marketing questions associated with the cattle cycle, then regarded as the chief affliction of the beef industry, dwarfing the problems identified in their earlier survey. This excellent study (DeGraff, 1960), titled Beef Production and Distribution, still stands as the most comprehensive and complete documentation of the cattle cycle. It pointed out (pp. 43-44) that analysis of the cattle industry is complicated by the fact that managers face a wide range of decisions regarding disposition of their cattle:

"An animal may be marketed at any age. A calf may be sold as veal when only a few weeks old or raised as a beef calf and slaughtered while still in calf flesh, or raised to maturity on grass. It may be put into a feedlot after grazing and fed for either a short or long period before slaughter -- or, as still another alternative, it may be kept as breeding stock and not sold for slaughter until it reaches the age of perhaps as many as 15 years."

In his preface, DeGraff (1960, pp. v-vi) noted that three generations of cattlemen had lived through repeated successions of boom or bust; and that the most recent of these busts had caused such great hardship that cattlemen were ready to face "the need to smooth out the historic cyclical pattern of the cattle industry." Though admonishing cattlemen to stabilize their culling and replacement proportions, con-

tinuation of the cycle was correctly anticipated, as if realizing that the cattlemen could not or would not stabilize.

Perhaps the Greeks were the earliest sufferers of the cattle cycle. Aristotle (384-322 B.C., Book VI, Ch. 21) may have been referring to the economic climate for cattlemen as he wrote:

"When kine in large numbers receive the bull and conceive, it is prognostic of rain and stormy weather."

The next major study framed the cattle cycle in terms of a "harmonic motion" model: stimulus, response, and feedback for delayed alteration of the stimulus. In this study, Ehrich (1966, p. 12) provided a more empirical version of Lorie's (1947, p. 56) model of the interrelations of beef market prices, quantities marketed, and beef cow numbers. While Ehrich explained (p. 8) that his cattle cycle model was derived from Larson's (1964) harmonic hog cycle model, Larson (p. 380) had stressed that "in all essential respects" his hog cycle model was identical to Lorie's (1947) cattle cycle model!

Ehrich's statistical analysis allowed him to conclude that exogenous forces were not the primary cause of these cycles, and that the cycle in prices is significantly affected by inventory decisions at the producer level (p. 17). Ehrich further affirmed the "view that producers respond incrementally to deviations of price from equilibrium" and, therefore, denied "the existence of a conventional supply function for beef cattle" (p. 25).

Business cycle theory provides some useful notions for considering the cattle cycle. Tinbergen (1938, p. 35) pointed out the importance of the initial conditions assumed for the relative levels of capital good inventories, product marketings, and demand, in a business cycle model.

The initial levels are an expression of the phase of the cycle, implicitly determining the direction the model will take. Metzler (1941) discussed cycles of inventories in consumer goods, noting that replacement demand is destabilizing. The peculiar nature of cow inventories, as living capital investment items which are instantly convertible to slaughtered beef on the same market as their main product gives the cattle cycle a self-reinforcing mechanism not present in other industries. The breeding cows thus comprise a standing inventory of consumer goods as well as an inventory of capital goods.

Tinbergen and Polak (1950, pp. 178-181) described the "echo principle" of cyclic business investment patterns. That process begins as a large quantity of capital equipment, with limited useful life, is acquired at a given time. Another large investment in replacement equipment is undertaken as the original equipment is scrapped at the end of its useful life. Thus, the "echo" of the original investment is repeated at intervals roughly equal to the useful life span of the equipment. The authors cast doubt on the operation of this principle by noting that equipment items of a given type may provide varying lengths of service and are often repaired, part by part, rather than replaced completely. Tinbergen later (1951, p. 134) reiterated that "technical data on the lifetime of machinery make it plausible that the echo principle cannot be the only explanation of the business cycles."

For young heifers recruited to the cow herd there is irreparable attrition through natural death and culling (slaughter) for ill health in addition to culling by management choice on attributes such as current

pregnancy. As with machines with variable useful lives, some of these recruits may eventually reach an age of 15 years in the breeding herd.

Decisions at the level of individual herd investments in heifer recruitment and cow retainment thus seem central to the cattle cycle process. The durability and productivity of these investments are also of great interest.

Firm Level Cattle Cycle Strategies

The obvious "buy low and sell high" strategy is devilishly difficult to implement. Biological, financial and forecasting problems all enter the picture. Except when entire herds are sold at bankruptcy or estate liquidation auctions it is difficult to purchase sound commercial breeding stock. Cows sold through ordinary auctions are often the culls (or rejects) from local herds.

It is often difficult to obtain financing for the purchase of beef cows during a notoriously depressing national liquidation. During such times annual cow maintenance costs (for interest, feed, labor, etc.) may far exceed the sales value of the calf crop. This difficulty would not be so great if it were possible to accurately foresee future costs and prices.

Reviewing the historical price and cost series, unfortunately, provides little reliable information about the future. It is difficult to say, until after the fact, that cattle prices have indeed bottomed out or irreversibly passed their peak. Goodwin (1947, p. 196) wrote:

"If only a small part of the producers are cycle conscious they may profit heavily, and, what is remarkable, render a public service by unintentionally ameliorating the cycle."

How to be accurately "cycle conscious" is not revealed, and remains problematic. Nerlove (1958) has also contributed to the explanation of cyclical investment behavior in terms of "adaptive expectations". While helpful in understanding past behavior, one is left to speculate on the future. In the aggregate, cow/calf operators seem to have persisted in a "buy high, sell low" pattern while intending to do the opposite.

In what began as a study of firm level strategies for cow/calf operators through cattle cycles, the author carried out a number of intensive farmer interviews aimed at understanding the relevant decision space. Calf producers indicated that the question "at what age are cows culled?" could not be answered directly ... that it depended on too many things. In addition to the cattle price and feed cost situation, each cow was considered as an individual with respect to current pregnancy status, health, and mothering ability. A commonly expressed rule of thumb was that timely pregnancy is a key requirement for retainment. Cows not pregnant at weaning time are the main candidates for culling.

A number of studies have examined the options of cow/calf producers given the existence of long-run price cycles. A briefly annotated chronology of these studies is given in Table 1.2. While by no means a complete listing, these do indicate a variety of viewpoints for dealing with cattle price cycles.

A search for information on cow pregnancy and survival by age revealed that others had also sought such data for similar purposes (Kim, 1970; Rogers, 1971; Bentley, et al., 1976; and Jaske, 1976). The authors of these earlier studies had also been frustrated somewhat by the lack of organized information on the economically important attributes dis-

TABLE 1.2 CHRONOLOGY OF FIRM LEVEL CATTLE CYCLE STRATEGY LITERATURE

- Potter (1930): admonition for cattlemen to avoid regarding cyclical price movements as permanent changes
- Vrooman (1956): break-even analysis for weaner calf, yearling and 2 year old sales under cyclicly extreme price sets
- Gray and Plath (1957): survey results noting that only yearling steers were sold from most ranches in 1953, while in 1955 heifers comprised half of the yearling sales
- DeGraff (1960): budget analysis of several recruitment and culling strategies through a price cycle
- Jenkins and Halter (1963): dairy replacement decision model which shows changing optimal culling ages through time according to prices and cow performance by age
- Wheeler (1968): optimal herd inventory systems under conditions of certain and uncertain prices and forage production, with homogeneous cows
- Kim (1970): beef cow investment model: uniform age distribution, with no culling for conception failure
- Rogers (1971 and 1972): economics of "replacement" through price cycles, with uniform age distributions
- Oppenheimer (1972): perceived a 7 year cycle in cattle numbers, but noted that there is enough variation between the "peaks and valleys" that people can still go broke
- Castle, Becker and Smith (1972): discussion of decisions on adding or eliminating cattle enterprises in light of price cycles
- Helmers (1974): effects on the cattle price cycle and credit limitations on the growth of ranch firms
- Jarvis (1974): microeconomic beef cattle investment theory development: responses to price changes
- Bentley, Waters and Shumway (1976): simulation analysis approach to optimal "replacement" age decisions at various price levels
- Keith and Purcell (March 1976): questionnaire study of the expectations of Oklahoma cattlemen regarding the cattle cycle

TABLE 1.2 CHRONOLOGY OF FIRM LEVEL CATTLE CYCLE STRATEGY LITERATURE
(continued)

- Jacobs (1977, 1978, and 1979): lucid explanations of firm level options for cow/calf operators through cattle cycles
- Bentley (1979): simulation analysis of a cow/calf enterprise in a whole farm plan
- Valdes and Franklin (1979): beef price cycles in Colombia as background in a production risk simulation analysis
- Trapp and King (1979): recruitment and culling strategy model for a perfectly foreseen price cycle, by simulation analysis
- Whitley (1979): simulation analysis indicating minimum losses by selling weaned calves in periods of falling prices, and profit maximization in periods of rising prices by long yearling sales

FIGURE 1.2 SIMULATED CYCLIC CHANGES IN COW HERD AGE STRUCTURE:
DEMOGRAPHIC PULSE

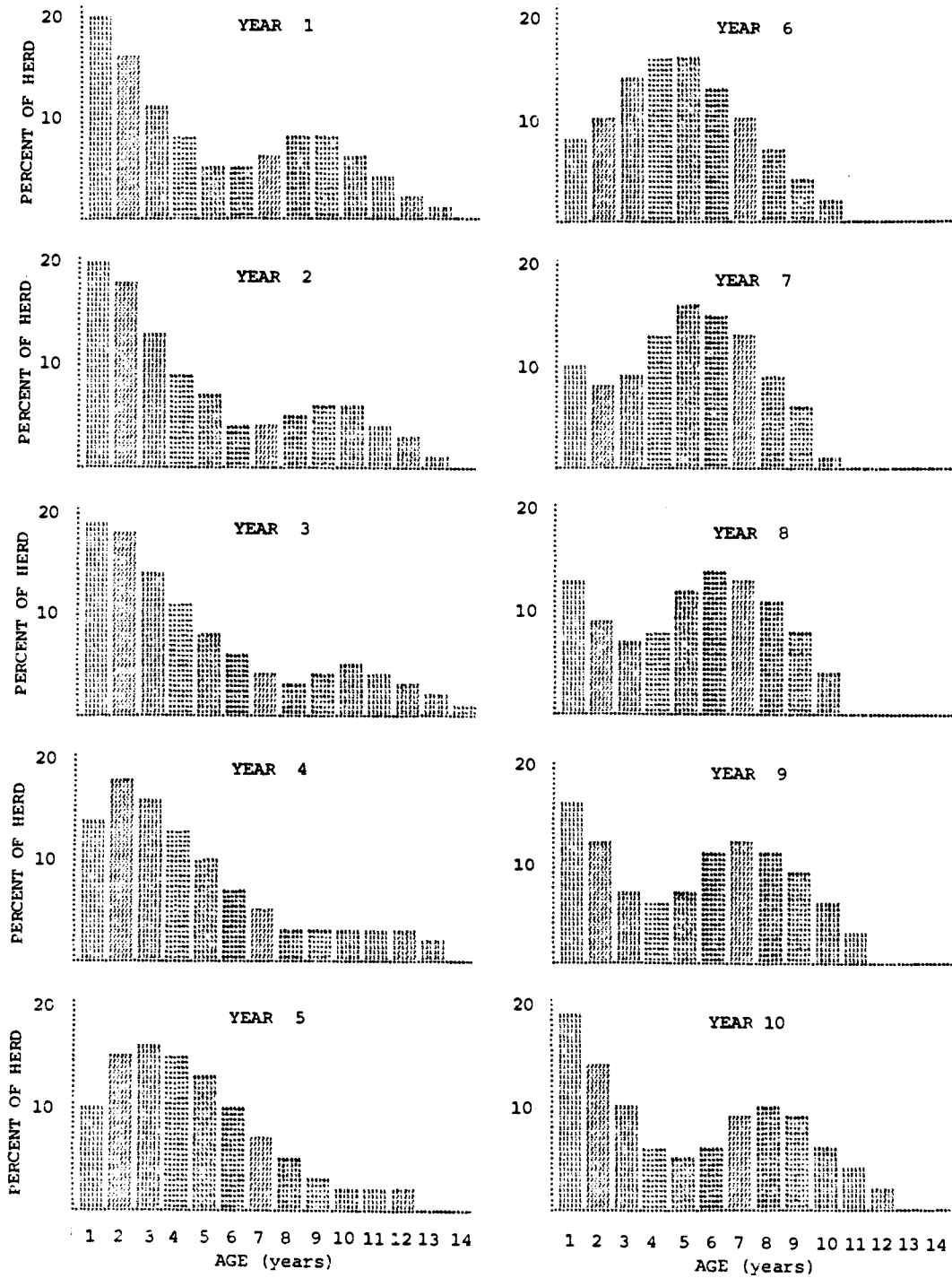

tinguishing cows of different ages. The expedient assumptions they used were distilled from individual animal science studies and practical rules of thumb.

Seeing the physical attributes of cow age couched in economic frameworks led to some general insights on the likely age structure of the national aggregate beef cow herd and those of the individual herds which comprise it. The author recognized that the very regular period of the cattle cycle could be associated with changes in the aggregate cow herd age structure.

Using Rogers' (1971) conception and survival rate assumptions, and decision rules suggested in the farmer interviews, the author designed a simple simulation model of cow demography, beef marketing levels, and price feedback. That model provided the graphic representation in Figure 1.2 of what might be called a "demographic pulse" in the aggregate beef cow herd. As illustrated in Figure 1.2, the age structure of the herd may undulate dramatically through a ten year cycle.

Changes in the apparent investment values of cows of different ages through times of relatively high or low prices (due largely to low and high quantities of beef marketed) are hypothesized to be at the root of such a demographic pulse. Wallace and Judge (1958, p. 16) wrote:

"Cattle producers, anticipating continuing price increases, retain young heifers and cows past prime productivity that would ordinarily be marketed in an attempt to restock depleted inventories."

The retainment of elderly cows was also noted in the U.S.D.A.

Livestock and Meat Situation report of November, 1962:

"Aged cows have been accumulated in breeding herds and will have to be replaced by heifers in future years. As this process of replacement gets under way, more heifers will

have to be diverted from feedlots to the breeding herd ..."
(p. 11).

The presence of a large proportion of "aged" or "past prime" cows during an accumulation phase of the number cycle is suggestive of the "echo principle" described above. Referring to the simulated percent-age-age-distribution graphs in Figure 1.2, years 1, 2 and 3 depict the last 3 years of an accumulation phase. Large numbers of young and old, but few of middle age, are shown. Year 4 marks the beginning of a liquidation phase, in which fewer heifers are recruited and many of the oldest cows are culled.

Year 7 depicts the hypothesized age structure of the herd at the end of the liquidation process. The bulk of the herd would be comprised of cows in their prime productive ages, with relatively few young or very old animals on inventory.

With the diminished herd size, and reduced slaughter marketings, cattle prices rise and in year 8 a new accumulation phase is under way. By year 10 the hypothesized age distribution appears very much like that of year 1. The 1 year old heifers in year 1 experience the least culling pressure through their lives. By the time the liquidation phase begins, they would be 4 years old entering their years of prime productivity. Furthermore, these animals contribute to the next accumulation phase as they are retained in the herd as 10 year olds in year 10. Finally, they would be among the first large group of "past prime" cows culled at the start of the subsequent liquidation phase, in year 13 or 14 (analogous to years 3 and 4).

The intuitive demographic pulse model expressed above gave rise to the idea of creating a value model which would consider historical costs

and prices to derive, for each age and pregnancy class of cows, relative value ratios through time. Such a ratio would express the present value of expected net future income relative to the cow's present slaughter value. It was hypothesized that such value ratios could be used to control a model of the internal age structure dynamics of the aggregate U.S. beef cow herd through cattle cycles.

Limitations on available data resolution, such as annual estimates of total beef cow numbers, have resulted in the fact that the "demographic pulse" has been largely invisible. The bioeconomic model developed in this thesis is designed to make that process visible for the first time.

Thesis Objectives

Four objectives are defined for the present study:

1. To describe the economically important biological characteristics of beef cows which change with cow age;
2. To develop a model of relative values of beef cows which considers the productive prospects for the futures of cows by age and through time;
3. To develop a national beef cow demography model which simulates recruitment and culling decisions through time, based on the value model;
4. To estimate the demographic changes of the U.S. beef cow herd, and the resultant changes in herd productivity, through cattle cycles.

Methodology

Mathematical simulation was chosen as the most convenient way to organize large amounts of information into operational relationships and to trace behavior which cannot be observed by examination of isolated system elements (Suttor and Crom, 1965). Unlike optimizing algorithms, a simulation model may be "as complex and as realistic as desired within the confines of available data and detailed structure of the system being modeled" (Dent and Anderson, 1971, p. 7). Trebeck and Hardaker (1972, p. 118) also noted the relative power imparted to simulation due to its freedom from the binding constraints on the form and size of optimizing algorithms.

Validation is an essential and ongoing part of the simulation modeling process. Overton (1977, p. 71) explained that "beginning with the first steps of the development of model structure and ending with the final steps of fine tuning ... validation and model building essentially end simultaneously".

Model structure ought to be compatible with knowledge of the real world processes modeled. There is a considerable element of art, and a strong role for intuition, in the choice of model structure. Overton (1977, p. 56) describes model building as an iterative process of structure specification, comparison with prescribed behavior, followed again by respecification and comparison until adequate behavior and "sufficient realism (adherence to accepted knowledge and theory)" are obtained. Halter and Dean (1965, p. 557) also described a process of incremental model revision "until it is an acceptable representation of the real system".

A model structure may have theoretical validity ex-ante but may be proved unable to meet the behavioral specifications and require modification. Another essential requirement is that the computer program for solving the model must be "debugged"; that is, it must be a true representation of the specified model, correctly executing the desired calculations. The "debugging" process may be a non-trivial and essential task but results only in validation of the computer program, not the model (Trueman, 1977, p. 633).

The subject of model structure validity comprises a good portion of Chapters 2, 3 and 4 of this study, on an equation by equation basis. The behavior of the whole model is compared, in Chapter 5, with available U.S. historical series on the annual inventories of (1) beef cows and (2) heifers and on the annual flows of (3) beef cows slaughtered and (4) calves born. Appended to the model and built-in to the computer program are a number of statistical routines, designed by the author, to facilitate this comparison. In addition to creating data files for comparison plots of each of the four series (simulated vs. historical), the model computes mean proportional absolute deviations, correlation coefficients, Theil's coefficient of inequality (U), and its decomposition statistics (Theil, 1966).

Synthesis

The model developed in this study is a synthesis of information and methods from four disciplines: economics, demography, animal husbandry and animal science. Thus, validity of the model may be judged from four viewpoints. Agricultural economists have often been guilty of over-

simplifying the decision space for livestock problems from the viewpoint of the animal scientist. Animal scientists, too, have sometimes been guilty of providing economic "bum steers" in their advice to farmers. This study is an attempt to strike a realistic balance that will be useful to both economists and animal scientists.

Only the essential details of the system should be included in the simulation model itself, not all that is known about cows nor all details of the beef market. The model is an abstraction, the aim of which is to capture the essence of the subject process.

Some brief preliminary notes regarding demography and cattle simulation models are given below. These provide part of the "picture of reality" against which the cattle demography model will stand for comparison.

Demography

Demographers have long been concerned with population age structures. The age structure graphic method in Figure 1.2 was adapted from the age pyramids of human populations. Demographers usually put the males on one side and the females on the other side, showing the numbers (or proportions) of each population by age group, with the youngest at the bottom and the oldest at the top. These graphs are used to compare population structures of different countries (see: Jones, 1965; Keyfitz and Flieger, 1971; or Vielrose, 1965), or to compare changes in the age structure of a given country through time (see: Baldwin, 1975; Kuznets and Thomas, 1957; or Thomlinson, 1976).

The beef cow herd age pyramids are one-sided (the males are ignored) and shown with the youngest heifers at the left side and the oldest cows at the right. It is simply assumed that bulls are present in constant proportion (1 to 20) to the numbers of heifers and cows to be bred.

The scars of war may be clearly seen in human age pyramids as gouges in certain age groups (or birth-year cohorts). The distractions and separations associated with wars often are reflected in sharply lowered birth rates, followed by "baby booms" echoing the end of hostilities. Rarely have human populations been managed as ruthlessly as cattle populations. There are Biblical accounts of instances when death sentences were pronounced for all individuals in specific age classes. On one occasion the Egyptian Pharoah ordered the slaying of all male infants of the Hebrews (Exodus 1:22). On another, Herod ordered the deaths of all male children, 2 years old and younger, in the Bethlehem area (Matthew 2:16),

Walters (1965, p. 10) referred to the tendency of the cattle industry to periodically be seized with "spontaneous optimism", and then "spontaneous pessimism". Such alternating outlooks are imputed to cattlemen from their investment behavior. The analogy of cattle cycle age structure changes with "baby booms" in human populations is not complete, but strong.

Though limited by the number of heifers weaned each year, the number of heifers recruited to the breeding herd is strictly a matter of choice by herd managers. Likewise, whether a cow of any age is retained in the herd for breeding, or culled from the herd and slaughtered, is a management decision. Because cows individually represent such large capital

investments, these retainment and culling decisions are usually made on an individual basis, considering the attributes and future prospects of each animal in relation to the others and in relation to its present slaughter market value.

Cattle Simulation Models

A number of national-scope simulation studies involving beef cattle have been developed. Several, which considered the cattle cycle process, are listed in Table 1.1. Others, not dealing with the cattle cycle, have been designed to allow national policy makers to consider the long-run consequences of different national cattle programs within development strategies. For example, Hayenga, et al. (1968) discussed the general usefulness and power of simulation in development studies, while Manetsch, et al. (1971) described a specific agricultural sector model, including the beef industry, of Nigeria. Miller and Halter, (1975) and Halter, et al. (1976) reported on systems simulation modeling of the Venezuelan beef industry. While distinguishing between the younger beef cattle classes and mature cows, it is fair to say that all of these studies, and all of those reviewed in Table 1.1, implicitly considered mature cows as a homogeneous class undifferentiated by age. Due to the lack of data, this is understandable.

In a number of firm level beef cow management models, cows are distinguished by age. Six of the studies listed in Table 1.2 consider different age classes of mature cows. However, five of these six considered "replacements" in the literal sense of replacing with a heifer any cow which dies or is culled from the herd for any reason. These were

studies by Jenkins and Halter, (1963), Kim (1970), Rogers (1971 and 1972), Bentley, Waters and Shumway (1976) and Bentley (1979).

Only Trapp and King (1979) correctly separated the culling and "replacement" decisions. They were correct in the sense of portraying the observed practices of cattlemen through cattle cycles: sometimes recruiting many heifers to the herd and sometimes recruiting few. Jarvis (1974) also assumed variable recruitment proportions, but with homogeneous mature cows.

Outside the list of firm level cattle cycle strategy studies (Table 1.2) are two others which distinguish mature cows by age: Schwab (1974) and Gebremeskal (1977). These are whole-farm models where breeding cows are one of several enterprises. Yager, Greer, and Burt (1980) studied strategies of feeding culled cows and deferring their sales to possibly take advantage of price seasonality. One point apparent in reviewing the above studies is that the decision space for regarding the retainment and disposition of beef cows is complex and not very well defined.

The national aggregate models reviewed commonly allow variable recruitment of heifers to a homogeneous mature cow herd; while most of the firm level models of heterogeneous herds, ironically, assumed constant recruitment proportions. The present national cow demography study assumes both variable recruitment and age heterogeneity.

Hierarchical decision models are conveniently handled by simulation (Gladwin, 1975 and 1976), thus the population dynamics of the national beef cow herd is susceptible to analysis by such means. For an individual herd, Powers (1975, pp. 13-14) shows samples of flow charts of hierarchical ageing and attrition processes by which weaned heifers become

cows through time. A similar process is developed in Chapter 4 of this thesis.

FLEX

A simulation modeling paradigm named FLEX has been developed at Oregon State University by W. S. Overton, Curtis White and others. It is based on the general system theory of George Klir (1969) and oriented toward ecological modeling, but not limited to that area of study (White and Overton, 1977). The FLEX modeling paradigm allows separation of the tasks of modeling and programming, organizing communication between the two through FLEXFORM model documentation.

The FLEXFORM document of the present model is given in Appendix A. The model is developed in a verbal text format in Chapters 2, 3 and 4, and the appended statistical routines are described in Chapter 5. The reader is often referred to the FLEXFORM for the uncluttered display of equations. The author has found the FLEXFORM method of documentation very convenient in keeping track of the model's development, especially in the "debugging" process. Every variable, parameter, and equation in the model is cross-referenced in the FLEXFORM for the specific purpose of facilitating criticism and implementation on other computing systems.

Too often, large and interesting models are designed, implemented and the results published, without preparing useable documentation. Such personal models do not lend themselves to criticism or communication easily, and may cease to exist, for practical purposes, when the programmers who designed them move on to other tasks. The author has spoken to

one programmer, who shall remain unnamed, who stated: "I don't like to document programs because I like to be indispensable!"

The authors of the FLEX modeling paradigm wisely insist on pre-documentation of models before computer implementation is commenced. Emphasis is placed strongly on modeling and communication rather than the details of programming (See: Overton, 1974 and 1975; White, 1977; Stimac, 1977; and Overton and White, 1978).

A brief explanation of FLEX notation is in order here, since it is used throughout the remainder of the text. This short list will serve as an introduction.

z_i = input variables

$x_{i,j}$ = state variables

$g_{i,j}$ = internal or intermediate functions

$f_{i,j}$ = flux functions to update state variables

$Y_{i,j}$ = output functions

b_i = constant parameters

Plan of the Thesis

Chapter 1 has served to introduce the reader to the general cattle cycle phenomenon, the author's "demographic pulse" hypothesis, the objectives of the thesis and its methodology.

Chapter 2 is devoted to a literature review and synthesis to organize the available information on the economically important biological attributes of beef cows which are functions of age. These are: conception rates, ($g_{1,j}$), unimpaired health rates ($g_{2,j}$), survival rates ($g_{3,j}$), body weights ($g_{4,j}$), calf weaning weights ($g_{6,j}$), and calf survival rates

$(g_{8,j})$. Considerable emphasis is placed on defining these "biological parameters" as point estimates from continuous functions of age, calculated by the intermediate functions $(g_{i,j})$ indicated above. In the current form of the model, these "biological" functions of age keep the same numerical values through the length of a simulation run, thus are referred to as "parameters". Management "expectation parameters" are also defined in Chapter 2.

Chapter 3 is concerned with defining the input variables (z_i) . Prices and costs are exogenous to the model. Cull cow price differences by age are modeled as functions of feeder steer and utility cow prices (annual input variables, z_i). Standard year (1978) budgets are then developed for five classes of breeding animals: weaned heifers kept for breeding, pregnant yearling heifers, non-pregnant yearling heifers, pregnant mature cows and non-pregnant mature cows. These 1978 annual variable cost budgets are comprised of 10 cost items on a dollars-per-head basis. The budgeted costs, item by item, are identified as "cost parameters" (b_i) for the model. Cost indices (1978 = 1.0) for each of the 10 cost items are developed for each year from 1950 to 1978, and identified as annual input variables, (z_i) .

Chapter 4 develops the core of the beef cow value and demography model. The model is designed to operate with a time resolution of 1 year, receiving annual input variables each year of the 29 year run.

The value model begins by estimating present and future cull cow prices, by age. Annual cost budgets are generated with the standard 1978 budgets and the annual cost indices (z_i) . This process may be likened to the reverse of Laspeyres' indexing process; here, multiplying

the base year (1978) bundles of costs by the subject year's respective cost indices (Longworth and Bos, 1978). Expected net annual revenues, and expected present values of net future revenues, are computed for each of 26 discrete age and pregnancy classes of heifers and cows. Ratios of these future incomes to the respective present slaughter values are computed for each of the 26 classes of breeding animals. These "V-ratios" link the value model to the demography model.

The number of animals in each of the 26 classes is carried as a state variable $(x_{i,j})$ in the demography model. Pre-culling inventories (after deaths, breeding and ageing) are computed for new pregnant and non-pregnant classes of each age. The proportion of animals in each pre-culling inventory class to be retained in the herd is a function of the respective class V-ratio. For each class, the numbers retained and the numbers culled are calculated. Summations are made for comparisons with the historical series of cows, heifers, culls and calves. All of the functions listed above for Chapter 4 are internal (or intermediate) $g_{i,j}$ functions. Finally, the $x_{i,j}$ state variables are updated by their respective flux functions, $f_{i,j}$.

The list of functions above are presented as a catalog of Chapter 4. The logic of this hierarchy of functions is given in some detail there. The functional forms are also given in the FLEXFORM, Appendix A.

Chapter 5 is devoted to model results, validation and conclusions. The statistical and graphical comparisons of simulated versus historical series for cows, heifers, culls and calves born are given there. Limitations of the model and indications for future research are also noted.

CHAPTER 2

BIOLOGICAL AND MANAGEMENT EXPECTATION PARAMETERS

Introduction

A major theme of this thesis is that commercial beef cows of different age classes (i.e., from 1 to 14 years of age) have different performance characteristics. In Chapter 4, a beef cow value and demography simulation model is developed. The biological characteristics of beef cows across age classes, and the expectations of cattlemen regarding the influences of these characteristics, are some of the basic building blocks of that model. The purpose of the present chapter is to develop those building blocks.

The literature review and synthesis of mathematical expressions describing the biological characteristics and management expectations are carried out in this chapter in the same order that these building blocks appear in the simulation model:

Conception rates by cow age	$(g_{1,j})$
Unimpaired health rates by cow age	$(g_{2,j})$
Cow survival rates by cow age	$(g_{3,j})$
Cow culling weights by cow age	$(g_{4,j})$
Maximum aggregate cow weight by cow age	(g_5)
Calf weaning weights by cow age	$(g_{6,j})$
Weight of weaned heifers kept for breeding	(g_7)
Calf survival rates by cow age	$(g_{8,j})$

Management Expectation Parameters:

Expected retainment rates $(g_{9,j})$
 and Expected fractional culling rates $(g_{10,j})$.

The reader will note the (g_i) terms, in the above list, are the names of the respective functions defined for the simulation model. The mathematical documentation of the entire simulation model is given in Appendix A.

Throughout this chapter considerable emphasis is placed on expressing the biological characteristics as point estimates from continuous functions of age. Two reasons for this are offered.

First, in the judgment of the author, the assumption of discontinuous biological character changes across cow ages cannot be justified on physiological grounds. In this study, the aim is to model the tendencies of a large population of animals (ranging from 15.9 million beef cows in 1950 to some 45.7 million in 1975). In so large a population, and large age-class subpopulations, within-age distributions of the identified characteristics may reasonably be assumed to have their centers along continuous functions across ages. Computational convenience is the second reason. Notation is simplified and ease of explication is enhanced by the use of continuous functions.

Conception Rates by Cow Age

The efficiency of a beef calf production enterprise depends on the fertility of the cows (Preston and Willis, 1970). A chief reason for a cow's removal from a commercial herd is failure to become pregnant (Greer, et al., 1980). Natural death and culling because of impaired health are

other forces of attrition on any group of beef cows. Impaired health and survival rates are covered in this chapter following the present discussion of conception rates. Assumptions regarding these and other reasons for cow culling and retainment are covered in the section on Management Expectation Parameters at the end of this chapter. There is considerable evidence that cow fertility is related to cow age. The purpose of this section is to review that evidence and define a set of fertility parameters for the aggregate beef cow herd.

Lasely and Bogart (1943, pp. 34-35) reported that fertility of heifers, between 2 and 3 years of age, was lower than observed for all older cows up through 10 years of age. Of the heifers exposed for breeding, only 66.1 percent calved. Cows, aged 5 and 6 years, had the highest fertility with an 86.2 percent calf crop. From the 6th year, fertility gradually declined with age, such that cows 9 and 10 years old had calf crops averaging only 69.2 percent.

Burke (1954) analyzed breeding and calving records for 4,470 pasture exposures of Hereford females over a 12 year period. This study also showed a pronounced effect of cow age on fertility, with a peak in calving rates for cows 6 and 7 years old at breeding. Beginning with heifers bred at 2 years of age (to calve at 3), there was a gradual increase to this peak, followed by a gradual decrease through 9 year olds. Cows older than 9 years showed a sharp drop in calving rates.

Cows as old as 16 years at breeding time, though few in number, were included in Burke's study. Yet, observations on all cows aged 10 years and over were reported as a single age category. The inclusion of such elderly cows in the study could account for Burke's report (p. 5) that

cows beyond 9 years of age had significantly lower fertility than any of the younger age groups. This may be reconciled with Lasely and Eogart's (1943) inference that the youngest cows were the least fertile by noting that cows older than 10 years were not considered in their analysis.

Stonaker (1958, p. 6) reported a large difference in calf crop percentage between 2 year olds and that for older cows. Over a 6 year period, only 54 percent of the 2 year olds exposed to bulls raised calves; while 80 percent of the cows 3 years old and over raised calves. Though some post-natal mortality must have entered in the determination of both of these statistics, they generally support the earlier cited studies in pointing to lower conception rates in young cows than in mature cows.

Crockett (1967, p. 270) reported that cows 4 through 9 years of age had similar reproductive performance (overall average conception rate of 83 percent), while conception dropped to 75 percent after 10 years of age. Baker and Quesenberry (1944, pp. 82-83) called cows aged 6 to 9 years "the mainstays of the herd". They suggested that cows reach their maximum production of weaned calves at 6 years, partly because the majority of the infertile, poor-producing cows are disposed of prior to that age.

Greer, et al. (1980, p. 15) showed, for a group of cows bred to calve first as 2 year olds, those least subject (under 15 percent) to culling by management criteria (chiefly, non-pregnancy) were the 4 to 6 year olds. Culling rates by such criteria increased markedly beyond 8 years of age, reaching over 40 percent for the 10 year olds.

The author's analysis of data on conception rates at the U.S. Meat Animal Research Center, Clay Center (1974-1979), indicates a rising pattern, beginning at 87 percent for young heifers, and reaching a peak of about 95 percent for cows ages 4 to 6 years. Unfortunately, conception rate data from this source is not yet available for the older age groups.

Long, et al. (1975), Jaske (1976), and Kay and Rister (1977) each assumed different cow fertility patterns for their economic studies. With fertility rising to peaks at 4 to 5, 5 to 7, and 6 to 10 years, respectively, and falling thereafter, their assumptions are in general agreement with the animal science studies cited above.

When the cow fertility data in any of the studies cited above are plotted against cow age, the result generally indicates rising fertility to a peak at some age (variously between 4 and 10 years) followed by a decline for cows aged beyond their prime. This suggests the shape of a downward opening parabola. Dickerson and Glimp (1975) described age effects on ewe fertility in similar terms, showing very pronounced parabolic patterns peaking at 4 to 6 years depending on breed. Evidently, such a functional form has been used to define cow fertility patterns by several others. These are discussed below.

A convenient form of quadratic equation has been adopted by the author for defining conception rate parameters across cow ages. The convenience is in regard to the direct biological meaning associated with two of the terms in the equation. The maximum conception rate, for example, is specified by the value of the b_1 parameter. The age of cows at which this maximum should be observed is specified by the value as-

signed to the b_3 parameter. The conception rate function is called $g_{1,j}$ in the simulation model.

$$g_{1,j} = C_j = b_1 + b_2(j - b_3) + b_4(j - b_3)^2$$

where: $g_{1,j} = c_j$ = expected conception rate for a cow aged j years at breeding

b_1 = maximum conception rate (When $b_2 = 0$)

b_2 = linear correction coefficient

b_3 = age of cow for maximum conception rate

b_4 = parabolic bend coefficient.

Table 2.1 lists the parameters which fit the above equation to the fertility estimates used by several other studies. The conception rate patterns derived from these other studies are plotted in Figure 2.1. With the exception of data from Burke, fertility patterns used by later studies were reported as lists of rates by cow ages, with only vague references to original data sources and no indications of goodness of fit. This point is mentioned here because, as the low mean error values in Table 2.1 show, the data lists used in the later studies were apparently taken from quadratic functions of cow age.

Kim (1970) used a set of cow fertility estimates based on those reported by Burke (1954). The author's own analysis of Burke's data suggests that Kim's extrapolation of estimates for cows ages 10 to 17 years was biased downward by the assumption that the rate reported for cows aged 10 and over would apply to cows about 10 1/2 years old. Yet, Burke reported that cows 16 years old were included in the data. The author assumes that the weighted average age of cows in Burke's "10 and over" class was 12 years, rather than the 10 1/2 years im-

FIGURE 2.1 CONCEPTION RATE ESTIMATES BY COW AGE

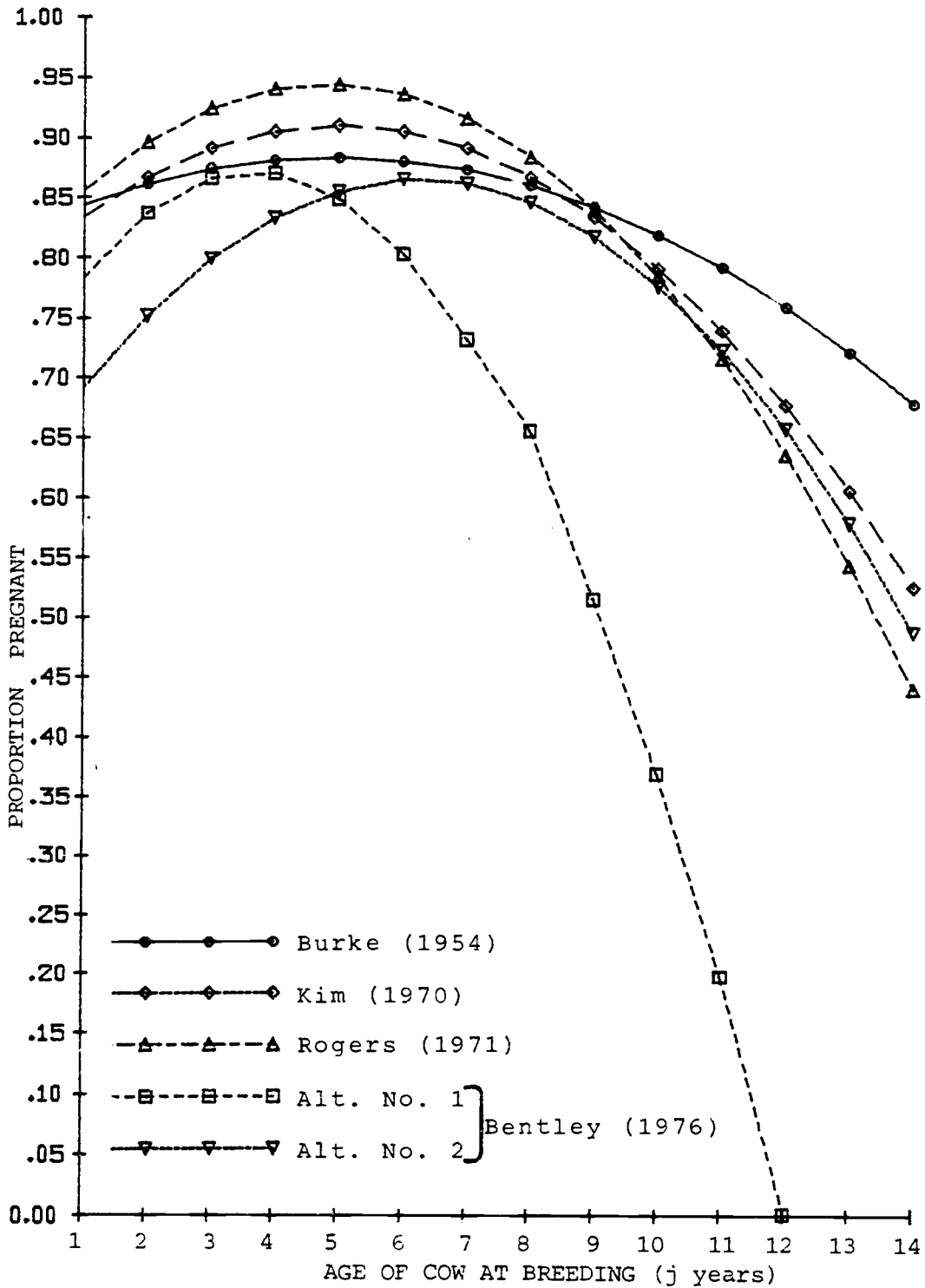

plicitly assumed by Kim. The author fitted the general conception rate equation to Burke's live birth data to derive the parameters, shown here in Table 2.1, and thereby generate the plot labeled "Burke" in Figure 2.1. The conception rate function plot and parameters based on Kim's (1970) interpretation of Burke's data are labeled "Kim" in Figure 2.1 and Table 2.1.

The studies cited above considered conception rates, calving rates or fertility rates for individual herds. The term "calving rate" is ambiguous where the practices of pregnancy testing and culling at weaning time are used. By removing non-pregnant cows from the herd prior to calving time, the number of calves born per cow on inventory can be shifted upward, arbitrarily approaching one. Conception rates, as measured by pregnancy testing at weaning time, are unambiguous and thus favored here for use in the simulation model.

At this point it is assumed that a quadratic conception rate function can adequately describe the national pattern of conception rates across cow ages. The specific function parameters, however, are still in question. The final assignment of parameter values in the conception rate function ($g_{1,j}$) must be deferred until their effects on herd averages can be examined in the context of the herd demography model's results in comparison with historical data series. This is done in Chapter 5 of the text.

Rogers (1971) assumed a set of "percent calf crop" parameters for cows 2 to 14 years old. These were partly based on the tendencies reported by Crockett (1967), Lasely and Bogart (1943) and Stonaker (1958) reviewed above. Rogers made an upward adjustment in light of Washington State data (Mueller, 1968) to give an average calf crop of 90 percent

TABLE 2.1 PARAMETERS FOR CONCEPTION RATE FUNCTION FITS TO EARLIER STUDY DATA

Parameter <u>a/</u>	Burke (1954)	Kim (1970)	Rogers (1971)	Bentley, et al., 1976	
				Alternative 1	Alternative 2
b_1	0.8822	0.91	0.94	0.871	0.865
b_2	-0.00275	0.0	0.01	0.004	0.0
b_3	5.5	5.0	4.0	3.5	6.25
b_4	-0.0025	-0.00475	-0.006	-0.0125	-0.0063
Mean Proportional Absolute Error <u>b/</u>	0.0025	0.0048	0.0117	0.0079	0.0054
Number of Data Points	n = 5	n = 14	n = 13	n = 11	n = 14

a/ Conception rate, by age (j) of cow at breeding = $g_{1,j} = c_j = b_1 + b_2(j-b_3) + b_4(j-b_3)^2$.

b/ $\frac{1}{n} \sum_{j=1}^n \left| \frac{D - C}{D} \right|$, where D = published data, C = point estimate from fitted function.

(assuming a uniform age distribution through 10 years, with attrition only by death).

Studies by Bentley, et al. (1976) and Trapp and King (1979) adopted Roger's estimates and extrapolated to find estimates for cows 15 and 16 years old, respectively. Two alternative sets of calving percentage parameters were also assumed by Bentley, et al. (1967) (see figure 2.1). These were based on two sets of unpublished data fitted separately as quadratic functions of cow age. Again, no indications of goodness of fit were offered. This is mentioned here because the pattern Bentley, et al. called alternative No. 1 shows near-zero calving percentages for cows bred as 12 year olds. These may be extrapolations from a quadratic function fitted to a data set for younger animals. All of these patterns are shown in Figure 2.1 while their function parameters are shown in Table 2.1.

Unimpaired Health Rates by Cow Age

Of all the biological parameters defined in this chapter, unimpaired health rates necessarily have the highest subjective content. A cow, after all, may be found to be pregnant or not on a given day. Similarly unambiguous is the question of whether a cow survived or died over a given period of time. But whether a pregnant cow is sufficiently healthy to survive and be productive in the coming year, requires a strong element of judgement for an answer.

In practice, borderline judgements on the health status of cows may be conditioned partly on the current economic outlook. For example, in times when high profits seem in store, a partially lame cow with a bad

teat, cancer eye and most of her teeth missing may be retained in the herd if there is some prospect that she will be able to wean a calf one year hence. In times when losses are being projected for the herd, such a cow would almost certainly be culled.

It is reasonable to expect that some cows, though surviving until weaning time, will be in such poor health that they will be removed (culled) from the herd regardless of the economic outlook. There is a considerable difference between the revenue expected from the sale of a cow culled for a health problem and the loss expected if she dies while still in the herd. A cow which is judged to have very poor prospects of weaning a calf in the next year is most likely to be culled.

Unimpaired health rates are defined in the present model as the maximum proportion of surviving cows in an age class that would be retained in a herd under the most favorable economic conditions. One might consider this proportion as the complement of seriously impaired health and undesirable characteristics. The role of undesirable characteristics is especially important in the case of rejecting weaned heifers from consideration for retainment and breeding.

In a steady state (constant size) herd, with attrition by natural death and culling for non-conception, only 40 or 50 percent of the weaned heifers will be retained for breeding. However, in times when herd size expansion seems desirable, perhaps as many as 75 or 80 percent of the weaned heifers may be kept for breeding. With unfavorable economic prospects, some herd managers retain none of their weaned heifers (Harrison, 1978). For the national herd, however, perhaps no fewer than 20 or 25 percent of the weaned heifer calves will be kept for breeding.

In the common terminology of animal husbandry, weaned heifers retained for breeding are called "replacement heifers" (Ensminger, 1976, Chapter 22, and Minish and Fox, 1979, pp. 104, 105). The presumption is that these heifers replace the older cows leaving the herd through culling or death. However, they are called replacement heifers even when kept in numbers too small to sustain herd size, or in large enough numbers for accelerated herd growth. A more proper term for these animals, in line with usage in other biological disciplines, would be "recruits".

The minimum proportion of weaned heifers not retained for breeding (but sold as calves) is implicitly included as the complement of the unimpaired health rate for animals of their age (becoming one year old). This is done for computational convenience, as a minimum proportion to be sold also defines a maximum proportion that may be retained for breeding.

The heifers which are selected for retainment will be the cream of the crop with respect to desirable conformation, condition, performance and genetic background. Thus, there is no particular suggestion that the minimum proportion of heifers sold are unhealthy. However, in the cases of the older cow age groups, the unimpaired health rates which define their maximum proportions retained, are based entirely on the expected incidence of serious health problems.

Baker and Quesenberry (1944, p. 80) described causes for culling, in addition to extreme age and conception failure, as poor physical condition, undesirable type and conformation, unsatisfactory calf production, and incidence of diseases such as brucellosis, lumpy jaw and cancer eye.

A multi-state survey of U.S. cattlemen in 1954 was reported by Ensminger, Galgan and Slocum (1955). That study provides estimates of aggregate frequencies of incidence for a comprehensive list of causes of bovine mortality and morbidity. A 14 year study of the life histories of 90 heifers kept for breeding was described by Pope (1967, p. 41). Over those years, 51 of the animals were removed from the herd for known reasons. Another 2 died and 5 were removed for unknown reasons. Of the 51, 24 were removed for failure to wean a calf in 2 successive years and 27 were removed for causes that could be classed as seriously impaired health. These were listed as "cancer eye, spoiled udder, disease, crippled and foreign objects".

Rogers (1971, p. 6) noted that culling diseased and barren cows would influence the age structure of the herd. Exploring this point specifically, Greer, Whitman, Woodward and Yager (1979), and Greer, Whitman and Woodward (1980), summarized the records for about 4,500 cows (including first calf heifers) which identified age at culling and reasons for culling from 1943 through 1976. Data on proportions of cows culled because of physical impairment (by cow age, from 2 to 10 years) was reported in Greer, et al. (1980, Table 8). A quadratic function was fitted to that data by the author after deleting the anomalous high observation for 4 year olds. The rejected observation for 4 year olds was a distant outlier from the otherwise smooth pattern formed by the remaining data points.

$$IH_j = 0.00539 + 0.0010437 j^2 \qquad R^2 = 0.9867$$

where: IH_j = Proportion of cows j years old culled for impaired health
 j = age of cow (years).

It was the practice at the Livestock and Range Research Station at Miles City, Montana, to cull all cows before reaching the age of 11 years (Greer, et al., 1979, p. 4). This was unfortunate since elderly cows (though rarely past 15 years of age) are found in commercial herds. However, the data reported by Greer, et al., are the best available and seem to provide a clear basis for the assumption of rising rates of impaired health with age. The fitted equation given above is used, in a modified form, to provide impaired health rate estimates for cows aged beyond those in the basis data.

The modification of the fitted equation consists of the addition of a hyperbolic term to accommodate the assumption that some minimum proportion (say 20 percent) of weaned heifers will be sold, even under the most favorable economic conditions. The constant term is altered also to give the cows becoming 5 years of age the lowest rates of impaired health. The modified equation is given here:

$$IH_j = -0.045 + \frac{.25}{j} + 0.0010437 j^2$$

For computational convenience in the simulation model the complement of the above equation is used. It is referred to here as the unimpaired health rate function, $g_{2,j}$.

$$g_{2,j} = 1.0 - \left(b_5 + \frac{b_6}{j} + b_7 j^2 \right)$$

where: $g_{2,j}$ = Unimpaired health rate: The maximum proportion of surviving cows or heifers (becoming j years old) that may be retained in the herd for the coming year. $j = 1$ to 15.

$$b_5 = -0.045$$

$$b_6 = 0.25$$

$$b_7 = 0.0010437$$

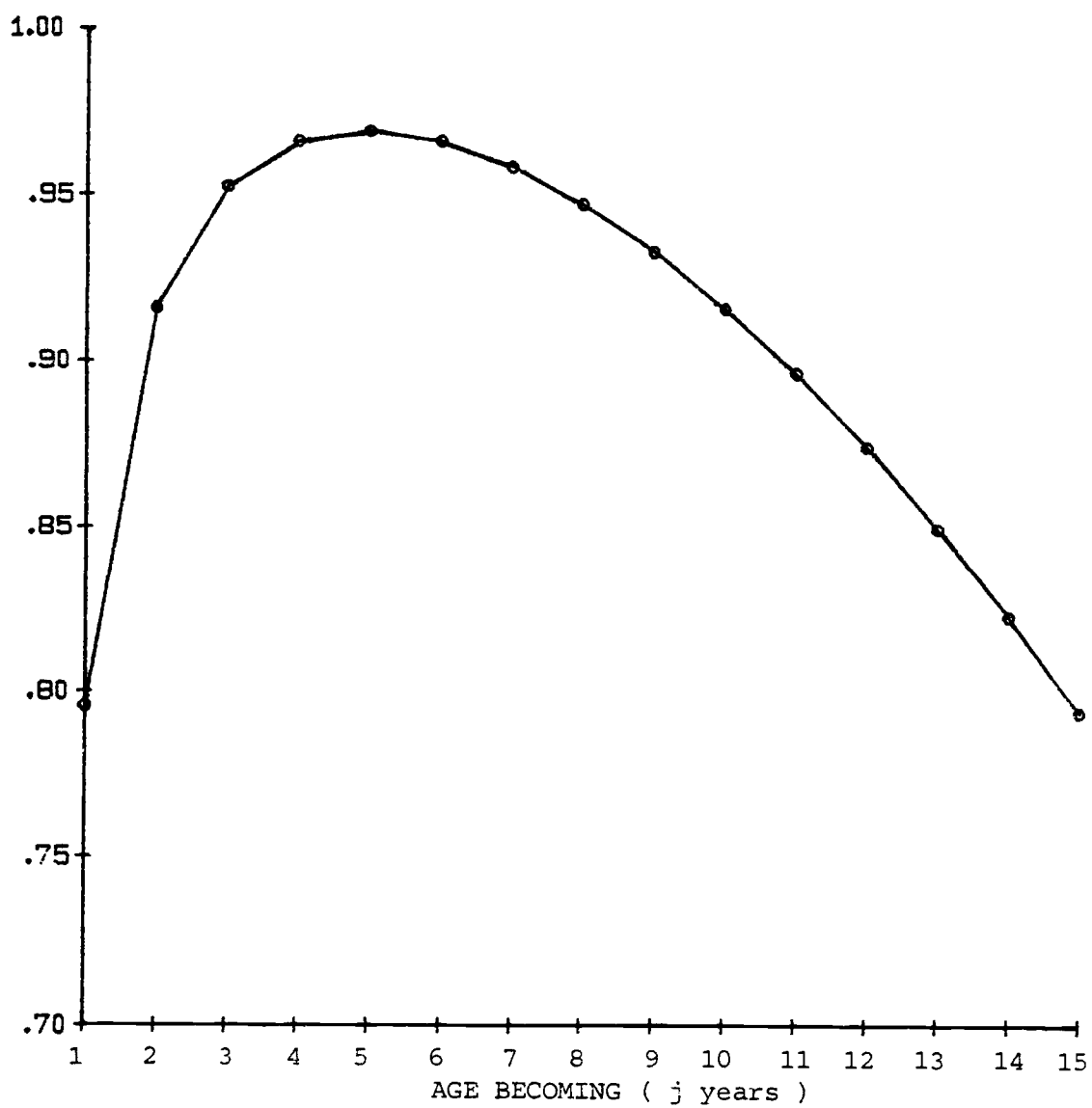
FIGURE 2.2 UNIMPAIRED HEALTH RATES ($g_{2,j}$)

The assumed unimpaired health rate function is plotted in Figure 2.2. The hyperbolic term (b_6/j) gives the equation the desired characteristic of showing progressively increasing maximum rates of retention for the younger age groups. The case of the weaned heifers was discussed above. The case of the heifers becoming 2 years old is one in which yearling heifers face their second selection hurdle. At this stage of maturity their growth performance, since selection as a weaned calf, receives considerable attention as does their conformation and condition. Many young cows, becoming 3 years old, will have experienced their first parturition. Though difficulties with first born calves are common, a particularly troublesome calving can be sufficient cause for culling. Such, but to a lesser degree, can also be the case for cows becoming 4 years old. By the age of 5 years, the normal selection process has eliminated most of the shy breeders, poor producers and weak cows (Baker and Quesenberry, 1944, p. 82). Beyond this age, the wear and tear of time take progressively heavier tolls on health.

Survival Rates by Cow Age

In commercial cow herds the ruthless annual selection and culling process sends most cows to slaughter before natural death can take them. If one includes cow deaths at calving time as accidental, it would be fair to say that most cow deaths on farms (other than intentional slaughter) are accidental and unusual; on the order of 1 to 2 percent in the aggregate. However, in a given year, a particular herd may experience no cow deaths or, in extreme situations of acute disease outbreaks, many.

Ensminger, Galgan and Slocum (1955) reported that their data from a 24 state survey indicated annual cow mortality rates of 0.59 percent from non-nutritional diseases and 0.32 percent from nutritional deficiency diseases and ailments (with bloat as the biggest killer). Greer, et al. (1980, p. 18) reported annual death losses for cows from 2 to 10 years of age at between 0.95 percent and 1.65 percent. Calf death losses are considerably greater, with calf scours and pneumonia as leading causes at ages under 2 months (Ensminger, 1976, p. 694; and Siegmund, 1967, p. 170 and p. 950). Calf death losses are treated in detail later in this chapter.

Lotka (1956, p. 110) stated that "in the populations with which the biologist and the vital statistician deals, the force of mortality varies very decidedly with age". Lotka shows survival curves for several species, including humans and *Drosophila* (pp. 107-109) noting their remarkable similarities. The slopes of such curves are, for the youngest ages, very steep (high mortality rates), gradually flattening to a minimum death rate (with the inflection for humans at about 12 years of age), then becoming steeper (higher death rates) continuously with advancing age.

The onset of puberty in beef females may occur over an extreme range in ages from 4 to 16 months (Preston and Willis, 1970, pp. 210-212), but most commonly at 8 to 12 months. As a safe rule they should be 13 to 14 months of age before they are bred (Ensminger, 1976, p. 1182). By puberty, the period of high post natal mortality is passed and the minimum rates of natural mortality are reached. The expected continuous rise in mortality rates, from puberty onward, however, is considerably

attenuated by the culling and sale of infirm cows. For economic ends, it is usually preferred that beef cows die in the slaughter house.

It is assumed in this study that the modified force of mortality on commercial beef cows can adequately be expressed as an increasing linear function of age. Further, it is assumed that the rate of increase is small; on the order of 0.1 percent per year of age. The complement of mortality is survival; which is, therefore, a decreasing linear function of age, as follows:

$$g_{3,j} = b_8 + b_9 \cdot j$$

where: $g_{3,j}$ = cow survival rate from natural and accidental death in the year prior to age (j). $j = 2$ to 15

j = age in years

$$\left. \begin{array}{l} b_8 = 0.99 \\ b_9 = -0.001 \end{array} \right\} \text{parameters}$$

Other authors (Bentley, et al., 1976, p. 14, and Trapp and King, 1979, p. 5), in analyses of replacement and culling strategies, used the pattern of cow death rates, by age, first assumed by Rogers (1971, p. 3 and 1972, p. 922). This pattern assumes slowly rising death rates, beginning at 2.25 percent, from the ages of 2 to 5 years, followed by a dramatic increase to 6.3 percent at 12 years of age, then leveling off at 6.6 percent by the age of 14 years. Such high mortality rates cannot apply to the national cow herd, in the judgement of the author, though they may have been observed in a particular herd.

Cow Weight by Cow Age

The sale of cull cows represents an important source of revenue, second only to calf sales, for a cow/calf enterprise. The purpose of

this section is to define a set of weight parameters appropriate for simulating culling weights by cow age for the disaggregated national herd.

Carpenter, et al. (1971) and Brown, et al. (1971) estimated parameters for models of cow growth for several breeds of cattle. These models describe growth in cow body weight up to asymptotic mature weight limits by 4 1/2 years of age, while others required more than 7 years. Long, et al. (1971, p. 60) show Hereford cow growth patterns which suggest attainment of peak body weight at about 7 years of age.

The author's analysis of cow weight data from the U.S. Meat Animal Research Center, Clay Center (1974 to 1979) indicates heavier mature weights but slower proportional attainment of maximum weight for exotic crossbreeds than shown for the early maturing common breeds in the studies cited above.

The early-maturing Hereford and Angus breeds represent a large proportion (as much as 62 percent, in 1954) of the gene pool of U.S. commercial beef cattle (Ensminger, et al., 1955, p. 46). In recent years, later maturing, heavier, exotic breeds have made some gains in popularity for crossbreeding programs (Ensminger, 1976, pp. 88-92).

Economic studies by Bentley (1979) and Trapp and King (1979) assumed beef cow growth patterns which fall roughly between those of the early and late maturing breeds when all are plotted as percent of 8 1/2 year weights, as shown in Figure 2.3.

Trapp and King (1979) borrowed their cow weight assumptions from Kay and Rister (1977). They showed a constant mature cow weight (at 1100 pounds), from the 6th through the 11th year of age, followed by

FIGURE 2.3 DATA ON COW BODY WEIGHT BY COW AGE

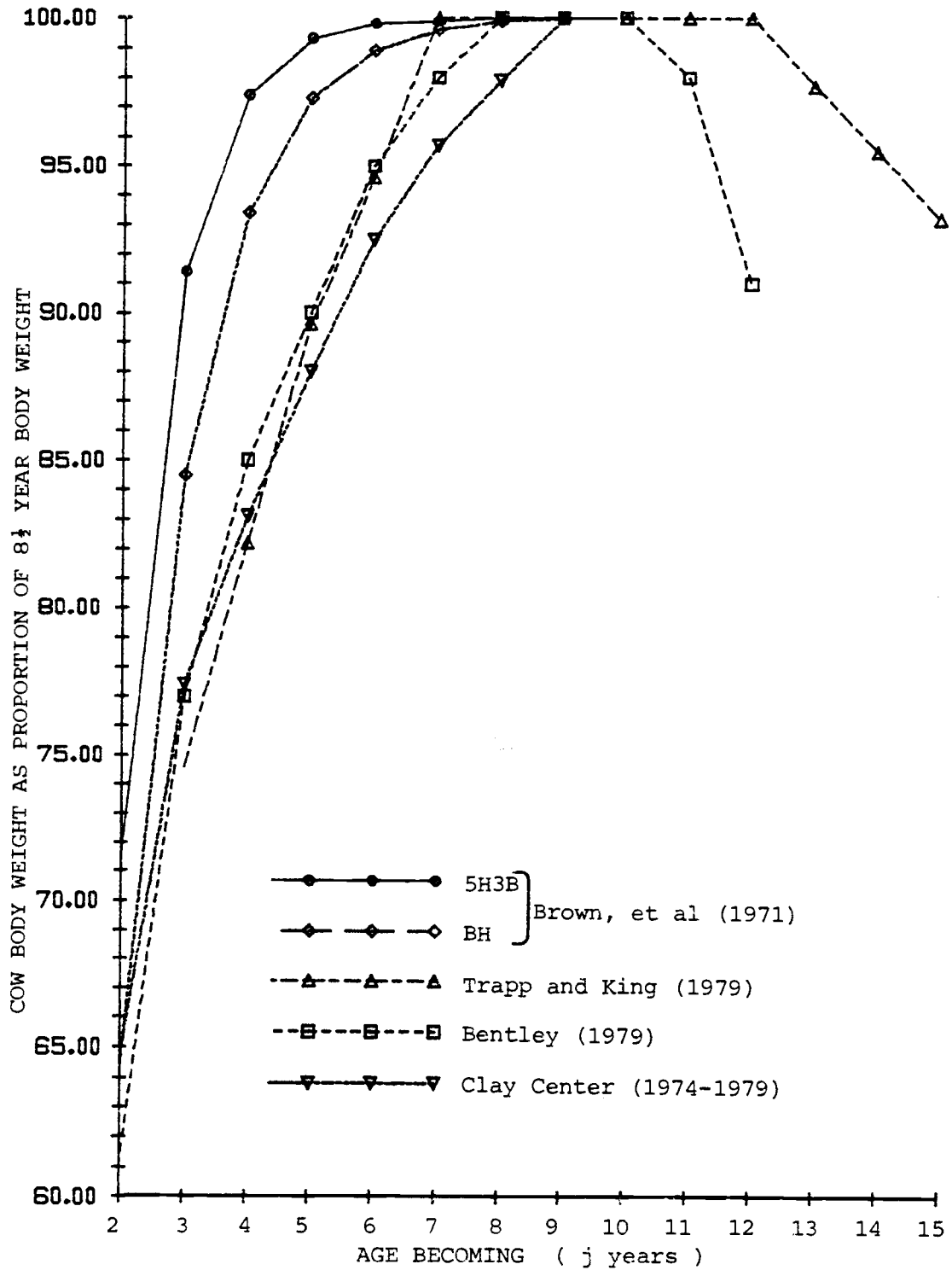

a linear decline (at 25 pounds per year) with further advances in age. Bentley (1979) assumed a constant mature cow weight plateau (at 1091 pounds), from the 7th through the 9th year of age, followed by a 92 pound drop-off over the next 2 years. Other authors have also suggested that weight declines are associated with advancing cow age.

Burke (1954, p. 6) asserted that nine year old cows often have higher salvage values than older cows, because they are in better flesh. Burlakov and Startsev (1961, p. 376) likewise stated that older cows yield carcasses which are lighter and of poorer quality than those of middle aged cows. Rogers (1971, p. 2) also assumed an age-related decline in cow value, but did not separate the weight and price components of the decline. Koger (1967, p. 242), in a budget analysis of culling practices, assumed a lower weight expectation for elderly cows than for non-pregnant cows in general: 950 pounds for cows culled on the basis of non-pregnancy and 900 pounds for cows culled for old age.

In addition to the studies cited above, two others by Pope (1967, p. 278) and Brown, et al. (1980, p. 43), point to the 7 to 10 year old age groups as representative of cows of mature weight.

The author has taken the growth pattern for the 5H3B cows (see Figure 2.3, and Brown, et al., 1971) to represent the extreme for early maturing breeds. It was also assumed that early maturing cow body weight would gradually fall to about 90 percent of maximum by the age of 14 1/2 years. A hyperbolic function of age (EW_j) was fitted by the author to this pattern to describe cow body weight as a proportion of the maximum for early maturing breeds (see Table 2.2 and Figure 2.4).

TABLE 2.2 COW WEIGHT PROPORTIONS BY COW AGE
FOR EARLY AND LATE MATURING BREEDS

Approx. Age	Age Becoming (j)	Proportion of Maximum Mature Cow Body Weight at Age of $j\frac{1}{2}$ Years	
		Early Maturing (EW _j) <u>a/</u>	Late Maturing (LW _j) <u>b/</u>
1½	2	.712	.657
2½	3	.878	.751
3½	4	.950	.826
4½	5	.983	.886
5½	6	.997	.931
6½	7	1.000	.964
7½	8	.996	.985
8½	9	.988	.997
9½	10	.977	1.000
10½	11	.964	.997
11½	12	.948	.989
12½	13	.932	.978
13½	14	.914	.966
14½	15	.896	.953

a/ Early maturing cow body weight as proportion of maximum (ME):

$$EW_j = b_{12} + b_{13}j + b_{14}/j \quad \text{where: } b_{12} = 1.33015$$

$$b_{13} = -0.0239$$

$$b_{14} = -1.1399$$

b/ Late maturing cow body weight as proportion of maximum (ML):

$$LW_j = b_{16} + b_{17}j + b_{18}j^2 + b_{19}j^3 \quad \text{where: } b_{16} = 0.4107$$

$$b_{17} = 0.1446$$

$$b_{18} = -0.01124$$

$$b_{19} = 0.0002673$$

FIGURE 2.4 EARLY AND LATE MATURING COW BODY WEIGHT PATTERNS

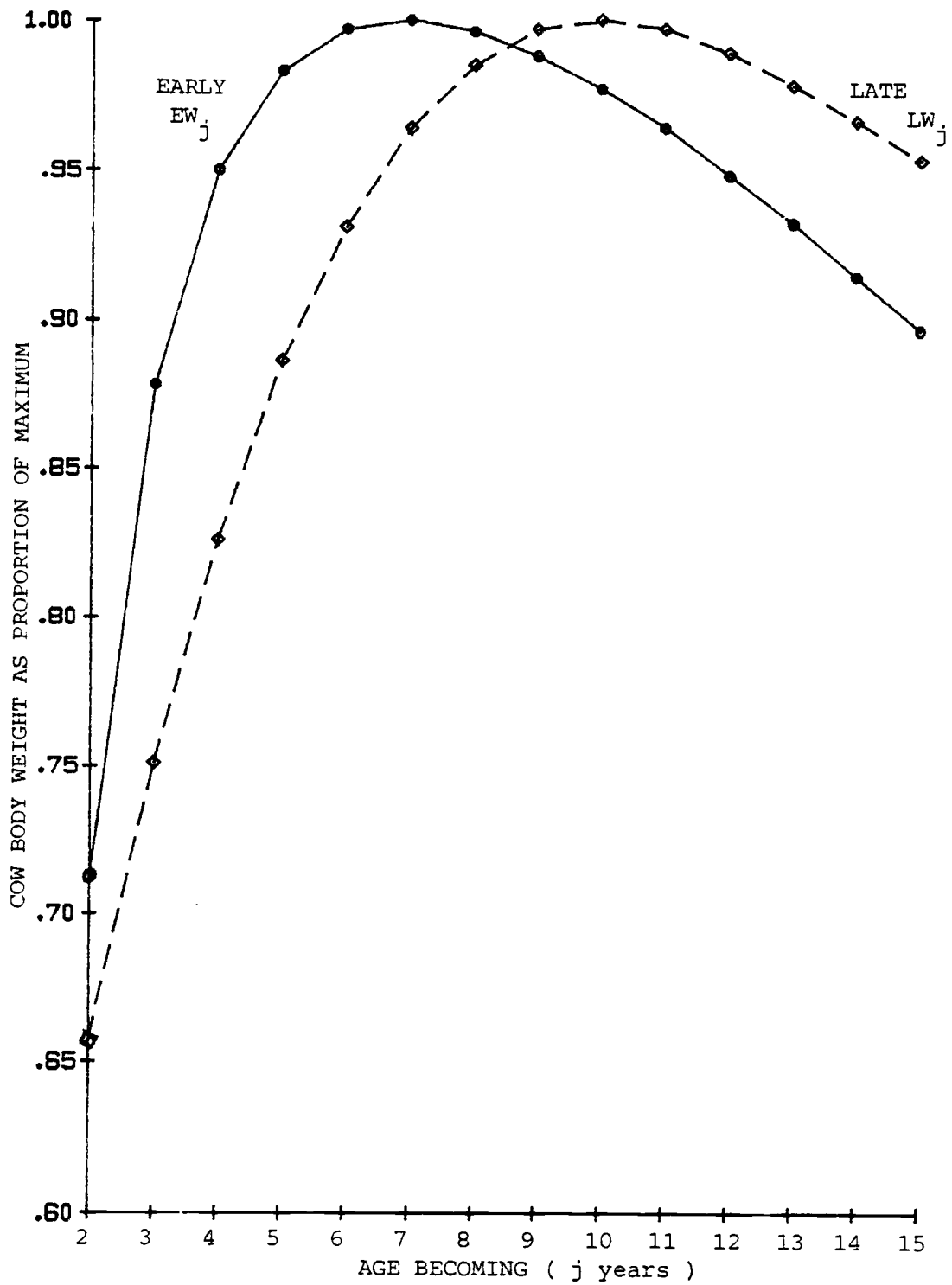

For the late maturing extreme, the author has assumed a growth pattern adapted from the Clay Center data (see Figure 2.3). It was further assumed that late maturing cow weights would gradually decline to about 95 percent of maximum by the age of 14 1/2 years. A cubic function of age (LW_j) was fitted to this pattern (see Table 2.2 and Figure 2.4). Other functional forms were tried and rejected by the author. The ones shown had the best fits to the assumed weight patterns.

Maximum mature cow weights (ME and ML) are specified for early and late maturing breeds, respectively. In order to derive specific culling weight estimates for each age of cow, a linear combination of the two extreme patterns times their respective maximum weights is calculated.

$$CW_j = (E \cdot ME \cdot EW_j) + (1.0 - E)(ML \cdot LW_j)$$

where: CW_j = Culling weight of a cow becoming j years of age = $g_{4,j}$

E = Proportion of the cow herd comprised of early maturing breeds = b_{10}

$(1.0-E)$ = Proportion of the cow herd comprised of late maturing breeds

ME = Maximum mature cow weight of early maturing breeds = b_{11}

ML = Maximum mature cow weight of late maturing breeds = b_{15}

EW_j and LW_j are as described in the text above.

The expanded form of the above cow culling weight function is used in the simulation model. Its terms have already been described above.

$$g_{4,j} = b_{10} b_{11} \left(b_{12} + b_{13}j + b_{14}/j \right) + (1.0 - b_{10}) b_{15} \left(b_{16} + b_{17}j + b_{18}j^2 + b_{19}j^3 \right)$$

The cow culling weight function ($g_{4,j}$) is computationally convenient in that it allows easy experimentation with different patterns across cow ages. The expected cow culling weights are used in the calculation of

expected cull cow sales values, by the functions $g_{13,j}$ and $g_{14,j}$, which are described in Chapter 4.

The cow culling weight formula ($CW_j = g_{4,j}$) has the desirable capacity to produce point estimates along a continuous function for any set of E, ME and ML parameter values. A continuous function is important here for avoiding biases in cow value estimation that could result from any sharp departure from trend in cow weight with age. Also, there seems to be no evidence in the biological literature for anything but a continuous pattern of cow weights with cow age (other than the usual annual fluctuations due to calving, lactation and changes in feed).

It was noted at the beginning of this section that roughly 62 percent of the U.S. beef cow herd in 1954 was comprised of early maturing Hereford and Angus breeds. The author, therefore, takes 0.62 as the initial value of E (b_{10}). The maximum weight of early maturing breeds (ME = b_{11}) is given an initial value of 1050 pounds (Brown, et al., 1980, p. 44). The maximum for late maturing breeds (ML = b_{15}) will be set at 1200 pounds (slightly below the highest Clay Center cow weights).

The aggregate maximum mature cow weight (MA = g_5) is simulated with the terms defined above. Calf weaning weights (discussed in the next section) are keyed to this aggregate maximum cow weight:

$$MA = (E \cdot ME) + (1.0 - E)(ML) = g_5 = b_{10} \cdot b_{11} + (1.0 - b_{10})b_{15}$$

Given the initial values assumed for the terms in MA (g_5), the aggregate maximum mature cow weight would be 1107 pounds. Long, et al. (1975, p. 411) reported an analysis of beef breeding systems which considered small, medium, and large breeds. The mature cow weights were 948, 1102 and 1322 pounds respectively. It is worth noting that their

"medium" cows had mature weights less than half of one percent lighter than the initial MA derived in the present study.

The equation for MA (g_5) will yield an estimate as much as 0.83 percent in excess of the maximum CW_j ($g_{4,1}$) for $1.0 > E = b_{10} > 0$. The reason is that EW_j is maximized at about $j = 7$ while LW_j is maximized at about $j = 10$. Since CW_j ($g_{4,j}$) is an average of these two functions (times their respective maximum weights ME and ML), weighted by E and $(1.0 - E)$, it will be slightly smaller than MA, which is a simple average of ME and ML, weighted by E and $(1.0 - E)$. However, this small bias is inconsequential because it can be corrected in the parameters linking MA to calf weights. The relationship between calf weights and cow age are discussed in the following section.

Calf Weaning Weights by Cow Age

A considerable body of literature indicates calf weaning weight is an important distinguishing characteristic separating cows of different ages. This characteristic is important because calf sales are the chief source of revenue for a commercial beef cow herd. The purpose of this section is to define a weaning weight - cow age relationship appropriate for simulating that of the disaggregated national herd.

A report by the Germ Plasm Evaluation Program at Clay Center, Nebraska (U.S. Meat Animal Research Center, 1974, p. 3) shows calf weaning weight adjustment factors calculated to put cows of various ages on a standard basis. The key indications were that 2 year old cows wean the lightest calves and that weaning weights increase at a decreasing rate with cow age up to 5 years. Pope (1967a, p. 38) shows similarly

shaped patterns of calf weaning weights by cows maintained on low, moderate and very high levels of winter nutrition.

Preston and Willis (1970) have provided a comprehensive review of animal science studies on calf weaning weights. They list the deviations from overall average calf weaning weights, according to cow age, for each of 15 studies. Data from seven of these studies were selected for analysis by the author. Each of the selected studies was based on at least 1300 calf records and average weaning ages of at least 190 days. Table 2.3 shows the selected data and the calf weight indices (I_j) derived from them.

The calf weight indices in Table 2.3 are based on the observation that the heaviest calves were weaned by the 8 year old cows. A cubic function was fitted to these calf weight indices by the author to give smoothed estimates of calf weight, relative to calves weaned by 8 year old cows, for each age of cow. This function (WI_j) yields smoothed calf weaning weight indices across cow ages, as plotted in Figure 2.5.

$$WI_j = b_{21} + b_{22} j + b_{23} j^2 + b_{24} j^3 \quad R^2 = .971$$

where: WI_j = Estimated weaning weight of calf from a cow j years old, as proportion of calf weaning weight from 8 year old cow

$$b_{21} = 0.770156$$

$$b_{22} = 0.0678788$$

$$b_{23} = -0.00642507$$

$$b_{24} = 0.000187646$$

Again, other functional forms were tried and rejected by the author on grounds of poorer fits.

TABLE 2.3 CALCULATION OF CALF WEANING WEIGHT INDICES BY COW AGE

Study No.	No. Of Calf Records In Study	Average Calf St. In Study (Kg.)	Calf Weaning Weight (Kg.) by Age of Dam (j)												
			$(w_{ij})^a/$												
			(i)	$(N_i)^a/$	$(\bar{w}_i)^a/$	j=2	j=3	j=4	j=5	j=6	j=7	j=8	j=9	j=10	j=11
1	1,987	183	159	173	182	188	194	188	188	183	183	178	170	185	175
2	1,306	204	-	190	194	199	202	204	204	204	-	-	-	-	-
3	1,372	266	250	260	267	269	267	268	267	273	273	272	272	272	272
4	2,351	189	164	180	187	191	199	200	201	197	194	190	183	182	182
5	1,627	176	170	170	178	178	181	181	181	181	178	-	-	-	-
6	13,937	189	177	177	189	192	195	196	197	197	196	196	195	196	193
7	2,516	212	192	197	197	207	214	215	221	218	218	218	218	218	218
Calf Weight Index ^{b/} (I_j)			.889	.907	.954	.973	.992	.994	1.000	.996	.992	.989	.978	.988	.973

a/ Source of data (N_i , \bar{w}_i , and w_{ij}): Preston and Willis (1970) pp. 234-235. Study Locations: i = 1, Virginia; i = 2, Hawaii; i = 3, Canada; i = 4, South Dakota; i = 5, Colorado; i = 6, Oklahoma and i = 7, United Kingdom

b/ Calf weight index calculation:

$$I_j = \left(\frac{\sum_{i=1}^{AD_j} N_i w_{ij} / \bar{w}_i}{\sum_{i=1}^{AD_j} N_i} \right) / \left(\frac{\sum_{i=1}^{AD_8} N_i w_{i,8} / \bar{w}_i}{\sum_{i=1}^{AD_8} N_i} \right)$$

where AD_j = available data for j year old cows.

FIGURE 2.5 CALF WEANING WEIGHT BY COW AGE

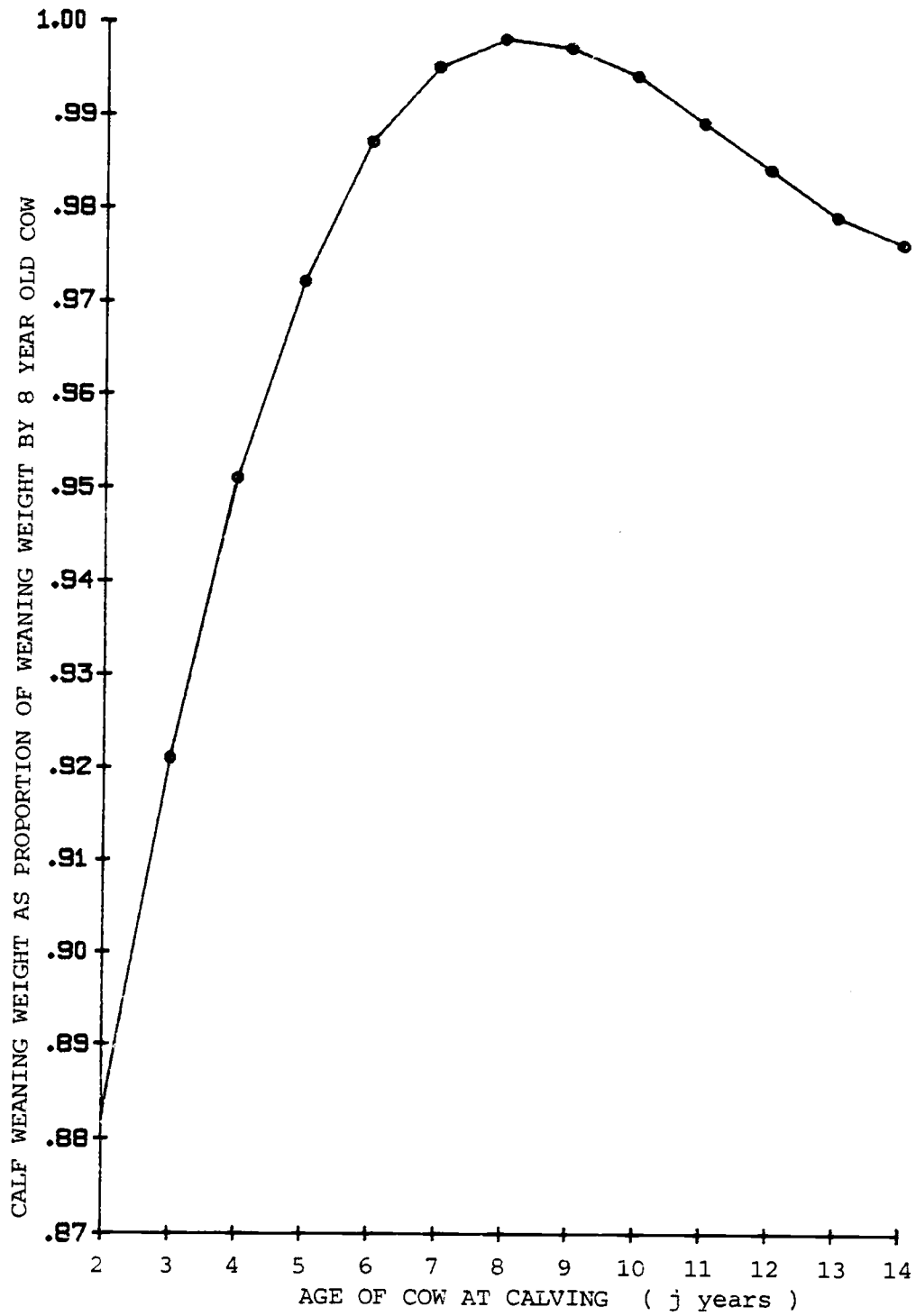

The data in Table 2.3 show that the lightest calves were weaned by the first calf cows and that maximum weaning weights were obtained with cows 6 or more years of age. Only slight declines in calf weaning weights were recorded for cows aged beyond the occurrence of their respective maxima.

Animal scientists have determined that a cow's potential to wean heavier than average or lighter than average calves through her productive life is an inherited trait (Stonaker, 1958, pp. 21-27). Thus, considerable interest has been shown in developing methods for identifying cows in the herd whose progeny will likely express the high weaning weight characteristic when recruited into the breeding herd (Minish and Fox, 1979, pp. 22-34).

The ages of calves weaned from a cow herd in a given year will typically be spread out with a difference of perhaps 2 months between the youngest and the oldest. Because calves gain weight rapidly from birth, weaning weight increases with weaning age. The ages of cows will also be distributed from young to old, generally with more younger than older cows (much more discussion of this later). Weaning weights adjusted to a standard weaning age basis (often 205 days) are usually further adjusted for age of dam to a "mature cow" standard. For this latter adjustment, one finds various recommendations for use of "additive factors" (Minish and Fox, 1979, p. 32) or "multiplicative factors" (Ensminger, 1976, p. 306).

While the recommended adjustments for age of cow generally follow the pattern developed in Table 2.3 (and in the function WI_j), they indicate discontinuities (long linear segments joined at sharp corners)

which could unnecessarily bias an economic study of this sort. In fact, such discontinuous adjustment factors were the basis of assumptions on calf weaning weights in several firm-level management studies (Rogers, 1971; Bentley, Waters and Shumway, 1976; and Trapp and King, 1979).

Rogers (p. 2) assumed a sharp drop in weaning weights after the eighth year of age, while Bentley, et al. (p. 14) assumed a similarly sharp drop for cows beyond ten years of age. It is not surprising that both of these studies pointed to optimal culling of cows at ages no older than the year before assumed calf weaning weights took their respective plunges.

Part of the present study's purpose is to simulate the character of the aggregate cow herd, which is comprised of tens of millions of animals. One would expect no discontinuities across cow ages in a characteristic such as calf weaning weights. Thus, the cubic function (WI_j) shown above is adopted for the present study.

Carpenter, et al. (1971) reported that cows with heavier weights at maturity tend to wean heavier calves. From their data (p. 42), the author has computed the ratios of calf weaning weight to mature cow weight. Based on 16 or fewer cows each, these ratios had an extraordinary range, with the lowest at 0.364 and the highest at 0.502, compared with those derived from other studies. For example, Koger and Warnick (1967) reported 205 day weaning weights for a total of 684 cows, from which a weighted average ratio of calf to cow weights of 0.4796 was calculated. In a budget study elsewhere, Koger (1967, p. 242) assumed calf and cow weights which yield a ratio of 0.437. Trapp and King (1979, p. 5) assumed maximum calf and cow weights which give a ratio of 0.444.

Pope (1967, p. 278) reported calf and mature cow weights which yielded an average ratio of 0.416. A similar ratio (0.4177) is derived by adjusting weaning weight data from Brown et al. (1980) to a 205 day basis and dividing by the mature cow weights they report.

Based on the calf to cow weight ratios noted above, an estimate in the mid to low 40 percent range would seem appropriate for linking mature cow weight to maximum calf weight. Thus, the author assumes a ratio of 0.43 as the initial value for MC (b_{20}); the ratio of maximum calf weight to maximum aggregate mature cow weight in the simulation model.

Weaned heifers selected for potential recruitment into the breeding herd (HKB's) will be among the heaviest calves weaned in a given year, though perhaps slightly lighter than the heaviest of their steer siblings. Thus, the author assumes a ratio of 0.42 as the initial value for HC (b_{25}), the ratio of HKB weight to maximum aggregate mature cow weight.

Calf weaning weights by cow age, and the weight of heifers kept for breeding are keyed to MA (g_5), the maximum aggregate mature cow weight (defined above in the cow weight section), as follows:

$$WW_j = (MA \cdot MC \cdot WI_j) = g_{6,j} = g_5 \cdot b_{20} \cdot (b_{21} + b_{22}j + b_{23}j^2 + b_{24}j^3)$$

and

$$HW = (MA \cdot HC) = g_7 = g_5 \cdot b_{25}$$

where: WW_j = Calf weaning weight for cow aged ($j + 1/2$) years = $g_{6,j}$

HW = Estimated weight of a weaned heifer kept for breeding
(HKB) = g_7

MA = Maximum aggregate mature cow weight = g_5

MC = Maximum calf weight as proportion of MA = b_{20}

HC = HKB weight as proportion of MA = b_{25}

WI_j = Calf weaning weight for a cow aged ($j = 1/2$) years as a proportion of maximum calf weight (described in previous section).

Given an assumed maximum aggregate cow weight ($MA = g_5$) of 1107 pounds, and maximum calf weight as a proportion of MA at .43 ($= MC = b_{20}$), for example, the weaning weight of a calf from an 8 year old cow would be calculated at 475 pounds. In comparison, the calf weaning weight for a cow calving as a 2 year old is calculated to be 420 pounds, while that for a cow calving as a 14 year old would be 464 pounds.

The calf weaning weights, computed by the method above, are assumed to be the average weaning weight of heifer and steer calves for each age of cow. The weight expected for weaned heifers kept for breeding is calculated separately, as described above, at 465 pounds ($= HW = g_7 = g_5 \cdot b_{25} = 1107 \cdot 0.43$).

Cow Age and Calf Survival From Conception to Weaning

Calf deaths constitute very costly losses in the sense of increased overhead expenses per live calf weaned. The costs of retaining and maintaining a pregnant cow which subsequently loses her calf must be borne by other calf and cull cow sales. The purpose of this section is to define the relationship between cow age and calf survival from conception to weaning.

Ensminger, et al., (1955, pp. 48, 49) called "appalling" the 21.3 percent birth-to-weaning calf death losses calculated for all respondents to their large 1954 survey. By regions, they estimated calf losses at: 12.4 percent for the West; 40.8 percent for the South; 11.6 percent in the Great Plains; and 15.8 percent in the Pacific Northwest. High calf

losses have been reported elsewhere, also. Romita (1975, p. 26) estimated beef calf losses at 20 to 30 percent in Italy.

A report by the National Research Council (1968, p. 4) estimated that "over a period of years, the over-all prenatal and neonatal mortality of calves in the United States from conception to about 2 months after birth has been about 10 percent for beef calves". Similar estimates of 11 percent calf mortality, have been reported in the Netherlands (Harmsen, 1975, p. 28), and in the Southern U.S. (Temple, 1967, p. 17).

More recently, the Economics, Statistics and Cooperatives Service of the U.S.D.A. (1979, p. 11) reported an over-all birth to weaning calf mortality rate of 6.4 percent for the U.S. in 1977. The apparent lack of consistency in U.S. calf loss estimates cited above may partly be explained by differences in calf losses by cow age and different herd age structures through time. This point may be explored with the model developed by this thesis when herd age structure changes are simulated.

Ensminger (1976, p. 390) noted that first-calf heifers experience more difficult births and calf losses than older cows. He estimated that heifers lose ten percent of their calves compared with a 6 percent loss for cows of all ages in the U.S. Other sources suggest that losses by heifers are even greater. For example, expectations of 12 to 15 percent calf losses by heifers were reported by Pope (1967b, p. 175) and borne out also in data by the U.S. Meat Animal Research Center, as analyzed by the author in Tables 2.4 and 2.5.

The author has calculated the average percentages of calves weaned of those born for groups of several beef breeds, at cow ages of 2, 3, 4 and 5 or more years (U.S. Meat Animal Research Center, Progress Report No. 3, 1976, Table 2). Those calf survival percentages were 83.5, 91.4, 93.7 and 94.4, respectively. The calf losses implied are 16.4 percent for first calf heifers, down only to 5.6 for cows aged 5 years and older.

Other data on calf losses by cow age were gleaned from Progress Reports of the U.S. Meat Animal Research Center, as shown in Table 2.4. With the assumption that calf numbers were divided evenly among the cow ages, where losses were reported for combined cow age groups in Table 2.4, the author has computed weighted average calf losses for each age of cow. Subtracting each of the resultant estimates from 100, and dividing by 100, gave the average calf survival rates shown in Table 2.5.

A hyperbolic function of cow age was fitted to the average calf survival rate data, for 2 to 10 year old cows, shown in Table 2.5 (other forms were tried and rejected). This function was used to generate the calf survival rate estimates ($CS - g_{8,j}$) for cows 2 through 14 years of age, shown in Table 2.5. The point estimates of calf survival rates across cow ages, given in Table 2.5, are plotted in Figure 2.6. The estimates for the 11 to 14 year old cows are extrapolations beyond the base data set. Though only a slight decline in calf survival rates for the most elderly cows is indicated, there are two sound reasons for allowing these as default estimates.

First, the common practice of selective culling of open (non-pregnant) and unsound cows from the herd each year has the effect of leaving

TABLE 2.4 CALF LOSS DATA BY COW AGE

Age of Cow	Reference ^{a/}		Number of Calves Born (For Weighted Averages)	Calf Losses From Birth to Weaning ^{b/} As % of Calves Born
	Progress Report Number	Table Number		
2	2/2		635	11.6
2	4/26		213	11.8
2	5/4		235	14.9
2	5/11		458	16.7
2	6/25		259	8.7
2	7/5		170	14.5
2	7/7		421	9.7
	Weighted Average for two year old cows			12.48
3	2/4		427	8.7
3	4/1		664	9.0
3	5/9		210	8.0
3	5/13		220	8.5
3	7/9		268	7.4
	Weighted Average for three year old cows			8.51
4 & 5	4/3		714	7.8
4, 5 & 6	5/1		1382	6.8
4, 5, 6 & 7	6/1		2043	7.9
4, 5, 6, 7 & 8	7/1		2678	7.0
4, 5, 6, 7, 8, 9 & 10	4/30		942	5.7

^{a/} Sources: U.S. Meat Animal Research Center, Progress Reports.

^{b/} 100X (percent born* - percent weaned*) / (percent born*)

* Percent of cows alive at calving.

TABLE 2.5 ESTIMATION OF A CALF SURVIVAL FUNCTION
(Calves weaned per calf born)

Cow Age (j)	Average Calf Survival Rate <u>a/</u> by Cow Age	Estimates By Calf Survival Rate Function <u>b/</u> ($CS_j = g_{8,j}$)
2	0.8752	0.8794
3	0.9149	0.9083
4	0.9276	0.9219
5	0.9276	0.9293
6	0.9288	0.9336
7	0.9289	0.9362
8	0.9326	0.9376
9	0.9430	0.9384
10	0.9430	0.9386
11	NA	0.9384*
12	NA	0.9380*
13	NA	0.9373*
14	NA	0.9365*

a/ Derived from Table 2.4 data. See text. NA indicates data not available.

$$\underline{b/} \quad CS_j = g_{8,j} = b_{26} + b_{27} j + b_{28}/j \quad R^2 = .929$$

where: $b_{26} = .975463$

$$b_{27} = -.00184144$$

$$b_{28} = -.184779$$

* Estimates are extrapolations beyond basis data by $g_{8,j}$ function.

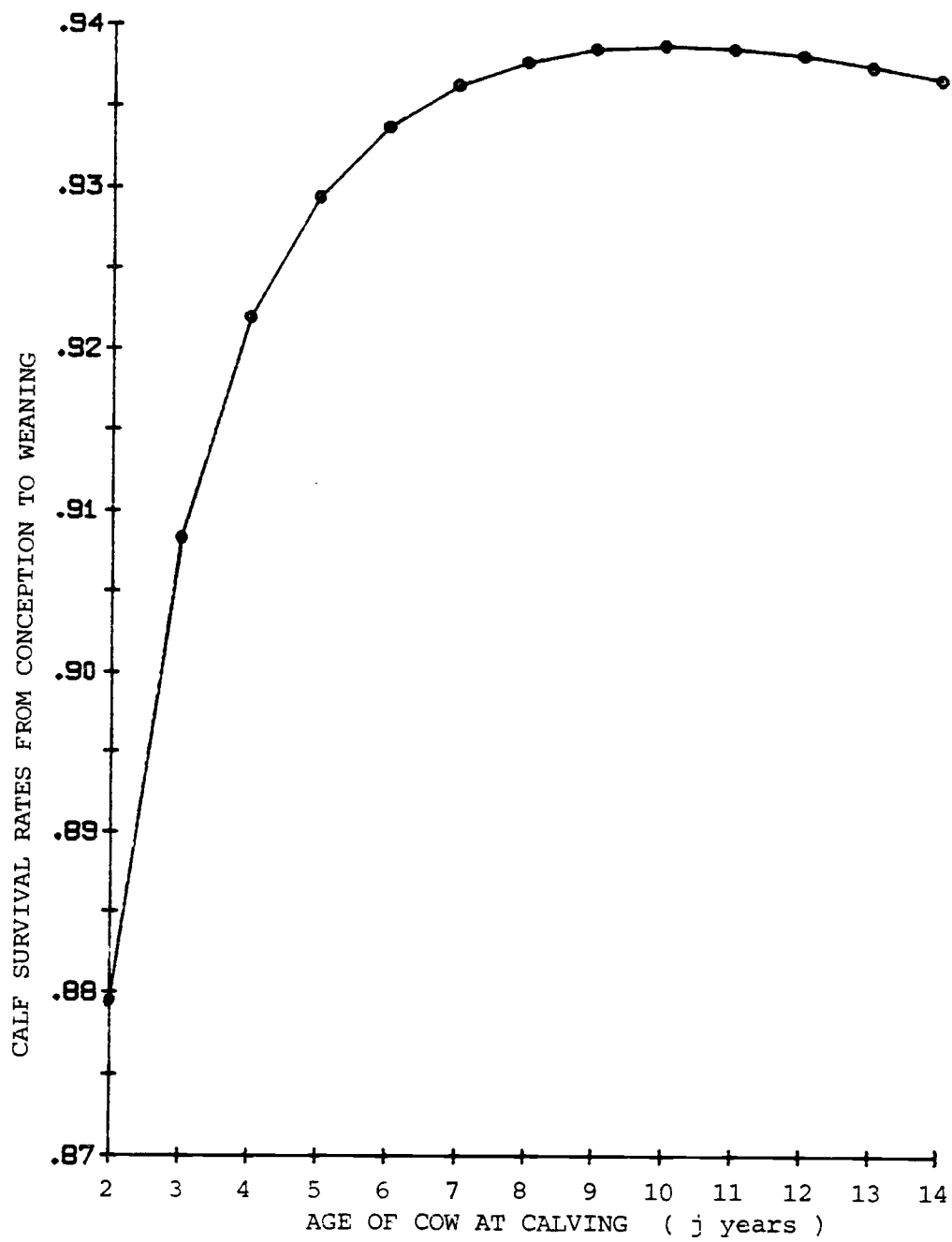
FIGURE 2.6 CALF SURVIVAL RATES ($g_{8,j}$)

only the most exceptional cows in the older age groups (Preston and Willis, 1970, p. 235). Under such culling pressures, a cow which remains with the herd into her teens is one which has truly proven her mothering ability (Baker and Quesenberry, 1944, p. 82). Secondly, there seems to be no basis for assuming a discontinuous pattern of calf survival rates with cow age. As with the other age-related biological parameters discussed in this section, it is very desirable to use point estimates for calf survival rates which lie on a continuous pattern.

Management Expectation Parameters

Intensive interviews of cattlemen by the author revealed a surprising degree of agreement on the practice of culling non-pregnant cows. Of the cow/calf managers questioned on the subject, all said they cull open (non-pregnant) cows soon after pregnancy testing or, if pregnancy testing is not done, as soon as non-pregnant cows are discovered among the calving cows (Buether, 1978; Burnet, 1978; Carlson, 1978; Davis, 1978; Erickson, 1978; Greiner, 1978; Hardie, 1978; Harrison, 1978; Holmes, 1978; Mobley, 1977; and Tatum, 1978). Several of those interviewed mentioned extenuating circumstances for keeping a non-pregnant cow in the herd. For example, "unless it's a good young cow" (Erickson, 1978), or unless "she's a real good cow" (Carlson, 1978), or "awful good" (Harrison, 1978). One said that he may "occasionally" keep an open cow, but that it "was not a good practice" (Greiner, 1978). Hultz (1930, pp. 78-79) noted that good cows which miss being bred in one year are not always dropped from the herd without another trial, while some ranchers make a strict practice of culling out every cow that does not produce a calf.

The admonition to cull all non-pregnant cows from commercial beef herds is found in many animal husbandry textbooks (i.e., Potter, 1930, p. 59; Ensminger, 1976, p. 1122; and Minish and Fox, 1979, p. 105) and extension publications (i.e., Fields and Warnick, 1974, p. 1003.4; and Stonaker, 1958, p. 9). However, from the data tabulated from their 24 state survey, Ensminger, et al. (1955, pp. 59-60) inferred that only about one-fourth of the barren cows in 1954 were culled. This interpretation is not totally supported by their data, in that another reason for culling (age), which would not have been mutually exclusive with barrenness, was listed. It is quite possible that the reason for culling most of the cows in the intersecting set of non-pregnant and older cows would have been reported as age. By this interpretation, the 1954 data could be read as showing that as many as three-fourths of the barren cows were culled.

One of the main themes in the very useful compendium of papers from a short course on factors affecting the calf crop (Cunha, et al., (eds), 1967) was that cows which are not pregnant or do not calve should be culled (specifically see: A.C. Warnick, p. 1, p. 31, and p. 352; Koger, p. 239 and p. 242; Reynolds, p. 259; and Cunha and Warnick, p. 365). These authors cited their own research, and that of others, to demonstrate the benefits of such culling in terms of increased herd productivity. They contrasted the potential productivity levels with the rather poor actual performance of commercial herds in the Southeast.

A consistent summary of the farmer interviews, research papers and textbook admonitions on the question of culling non-pregnant heifers and cows can be given in a few words: we know we should cull them all, but

we can't always bring ourselves to do it. An explicit model rationalizing the retainment of varying proportions of non-pregnant heifers and cows is given in Chapter 4 of this thesis. This seems necessary in the context of simulating the way things were, rather than how they "should have been".

In any budgeting exercise or present value calculation one must make assumptions about the likelihoods of the future occurrence of various states of nature. For example, to budget the expected net revenue from a cow over the coming year, it will be useful to have an estimate of the probability of having cull sale revenue from that cow at the end of the year. Also, where the present value of an expected future stream of costs and revenues for a cow is to be calculated, it is useful to have estimates of the likelihoods of a cow's continued retainment in the herd through the future years. Such estimates are called management expectation parameters in the present study. Their development is discussed here.

Expected Retainment Rates

A minimum of three elements enter the a priori expectation that a cow will be retained in the herd at the end of the coming year: The rates of conception ($g_{1,j}$), unimpaired health ($g_{2,j}$) and survival ($g_{3,j}$). Clearly, the proportion of cows, in a given age group, which die are out of the running. Of the survivors, it is assumed that only those which are both pregnant and healthy will be retained.

It should be emphasized here that retainment expectations defined according to the above assumptions are to be used only in the present value calculations of Chapter 4. The simulated demographic changes in

the cow herd are only indirectly influenced by these retainment expectations as they influence the apparent breeding value of a group of cows relative to their salvage values if sold immediately. Other limitations on the use of these expected retainment rates are imposed in the present value calculations described in Chapter 4.

In order to define the proportion of surviving cows which are both pregnant and healthy, it is assumed that the joint probability is simply the product of the probabilities of the two independent states: pregnancy and unimpaired health. This requires the explicit assumption that, within a given age group, the non-pregnant animals will have the same rate of unimpaired health as those that are pregnant; and that the animals with seriously impaired health will have the same conception rates as those with unimpaired health. These assumptions are adequate in the present application because they capture the essence of the observed process if not the precise proportions (which are not known). What has been observed is that the population of cull beef cows going to slaughter is composed largely of healthy non-pregnant, unhealthy (or unsound) pregnant, and unhealthy, non-pregnant animals. Conditions under which healthy non-pregnant cows may be retained, and conditions under which healthy pregnant cows are culled are examined later in Chapter 4.

Computational convenience has influenced the mathematical expression of expected retainment rates here. The definition of expected retainment rate is based on the expectations for the future of a weaned heifer kept for breeding. With the decision to retain a given weaned heifer for breeding as a 1 year old, the expectation that she will be retained for her first year in the breeding herd equals unity ($g_{9,1} = R_1 = 1.0$).

Now comes the question of the likelihood that this weaned heifer will be retained 1 year hence, for breeding as a 2 year old (that is, for retainment in the second year of her future). According to the assumptions given above, this likelihood may be expressed as:

$$R_2 = R_1 \cdot C_1 \cdot H_2 \cdot S_2 = g_{9,2} = g_{9,1} \cdot g_{1,1} \cdot g_{2,2} \cdot g_{3,2}$$

where: R_2 = expected likelihood that a weaned heifer kept for breeding will be retained (surviving, pregnant and healthy) in the herd for the second year in her future (i.e., for breeding as a 2 year old) ($g_{9,2}$).

$R_1 = 1.0$, by definition above ($g_{9,1}$)

C_1 = conception rate for 1 year olds ($g_{1,1}$)

H_2 = unimpaired health rate for heifers becoming 2 years of age ($g_{2,2}$)

S_2 = survival rate in the past year for heifers becoming 2 years of age ($g_{3,2}$).

Recall that conception rates ($g_{1,j}$), unimpaired health rates ($g_{2,j}$) and survival rates ($g_{3,j}$) were defined in the early sections of this chapter.

The expected likelihood that a weaned heifer will be retained (surviving, pregnant and healthy) for the third year in her future (i.e., for breeding as a 3 year old) may be expressed as:

$$R_3 = R_2 \cdot C_2 \cdot H_3 \cdot S_3 = g_{9,3} = g_{9,2} \cdot g_{1,2} \cdot g_{2,3} \cdot g_{3,3}$$

In general, then, the expected likelihood that a weaned heifer will be retained (surviving, pregnant and healthy) for the j th year in her future (i.e., for breeding as a j year old) may be expressed as:

$$R_j = R_{j-1} \cdot C_{j-1} \cdot H_j \cdot S_j = g_{9,j} = g_{9,j-1} \cdot g_{1,j-1} \cdot g_{2,j} \cdot g_{3,j}$$

This provides a concise definition of what may be regarded as an expected steady-state age structure, based on the likelihood of a weaned

heifer kept for breeding to be retained in the herd for her j th year in the future. It is clear that these retainment rates depend totally on the assumed conception, unimpaired health and survival rate patterns across cow ages. The only safe generalization we can make is that the steady-state age structure pattern (with retainment likelihood on the vertical axis, and cow age on the horizontal) is a monotonic decreasing function of age. That is, $R_1 = 1.0 > R_2 > R_3 \dots > R_{15}$.

Assuming conception rates derived from Burke, and unimpaired health rates and survival rates defined earlier in this chapter, expected retainment rates for a weaned heifer kept for breeding were calculated. These rates are shown in Figure 2.7. The real computational convenience of the present expression of expected retainment rates comes in their use in defining retainment rate expectations for the futures of each of the older age classes.

Here, $R_{i,j}$ is defined as the expected likelihood of retaining a cow, presently becoming j years of age, in the i th year of her future, if she is retained for breeding in the coming year. Using the weaned heifer-based rates, defined above,

$$R_{i,j} = \frac{R_{i+j-1}}{R_j} .$$

Notice that in general, for the first year of the future (i.e., the coming year),

$$R_{1,j} = \frac{R_{1+j-1}}{R_j} = \frac{R_j}{R_j} = 1.0 = \frac{g_{9,j}}{g_{9,j}}$$

The expression above has a simple interpretation. When the decision has been taken to keep a cow for breeding as a j year old in the coming

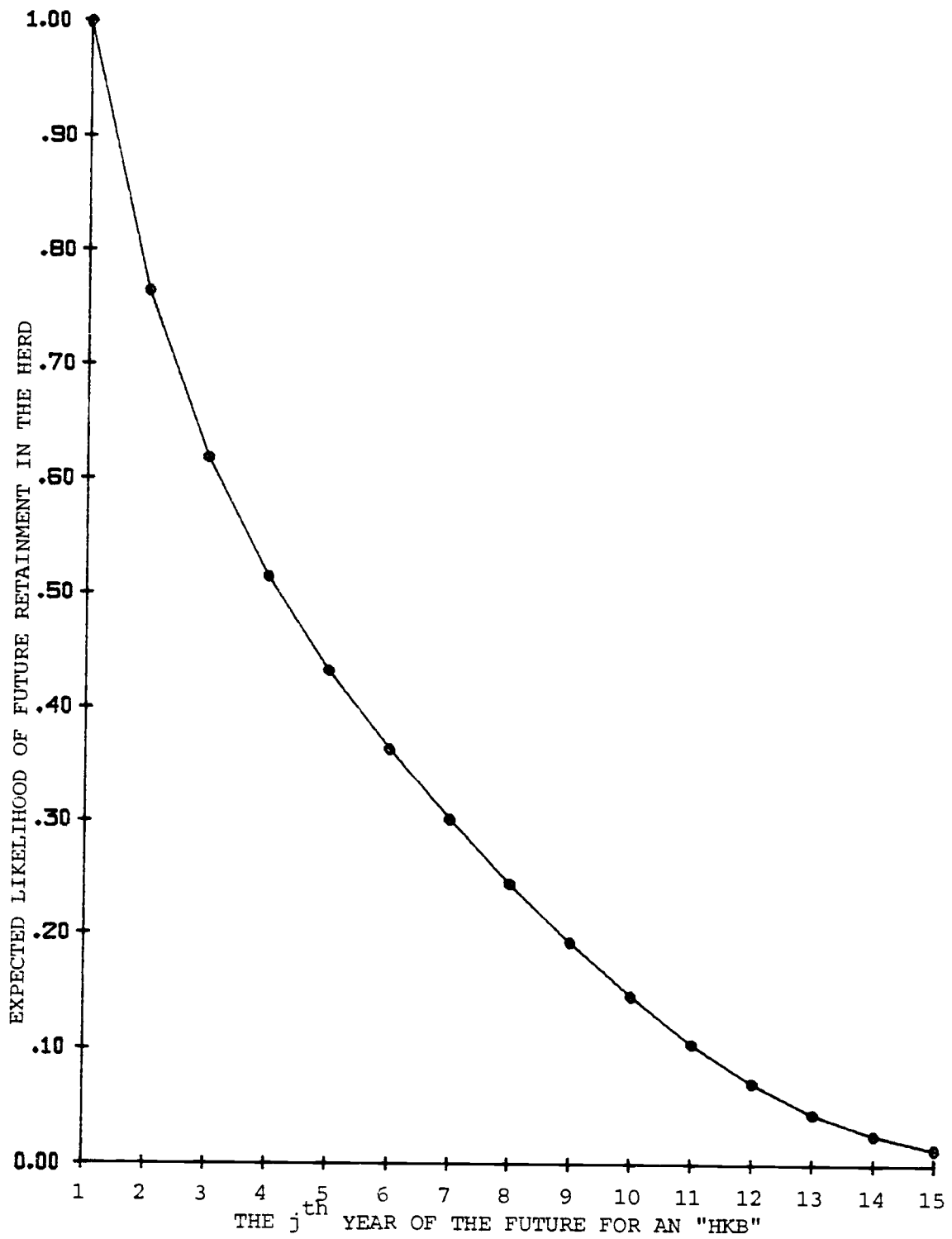
FIGURE 2.7 EXPECTED RETAINMENT RATES ($g_{9,j}$)

year, the retainment rate for the j th year in the future of weaned heifers kept for breeding (R_j) becomes the unity basis of retainment expectations for the future of the j year old cow. Thus, for example, in the case of a cow which is to be kept for breeding as a 5 year old in the coming year, the expected likelihood that she will be retained (surviving, pregnant and healthy) for breeding in the third year of her future is given by:

$$R_{i,j} = R_{3,5} = \frac{R_{i+j-1}}{R_j} = \frac{R_{3+5-1}}{R_5} = \frac{R_7}{R_5} = \frac{g_{9,7}}{g_{9,5}} .$$

The potentials a cow has for future calf production and cull sale are defined largely by her expected retainment rate sequence. In the present value calculations the retainment likelihoods scale down the more distant future cow costs and revenues relative to those expected in the near future. The process is described in Chapter 4.

Expected Fractional Culling Rates

Future cull revenues are weighted by the likelihood of a cull sale at the end of the year. A culling likelihood is calculated for each age group of breeding heifers and cows based on the weaned heifer retainment likelihood series described above. The likelihood that a cow, retained for breeding as a j year old, will survive to the end of the year but not be retained for breeding in the subsequent year, is defined here as the fractional culling likelihood. The fractional culling likelihood is computed as a simple proportional residual:

$$EX_j = \frac{(R_j \cdot S_{j+1}) - R_{j+1}}{R_j} = g_{10,j} = \frac{(g_{9,j} \cdot g_{3,j+1}) - g_{9,j+1}}{g_{9,j}}$$

where: $EX_j = g_{10,j}$ = fractional culling likelihood for next year

$R_j = g_{9,j}$ = weaned heifer-based retainment likelihood for jth year

$S_{j+1} = g_{3,j+1}$ = survival rates expected in the next year for a cow kept for breeding as a j year old.

Because the fractional culling rates are functions of the weaned heifer-based retainment rates, they are also totally dependent on the assumed conception, unimpaired health and survival rates. The fractional culling rates plotted in Figure 2.8 are based on the expected retainment rates shown in Figure 2.7.

The fractional culling rates are used in the calculation of net annual revenue projections for cows of each age and pregnancy class, in the simulation functions $g_{24,j}$ and $g_{25,j}$. These are described in Chapter 4, as part of the Cow Value model.

In the FLEXFORM documentation of the simulation model, given in Appendix A, all of the age-related biological and management expectation parameters developed in this chapter are summarized. The FLEXFORM also provides a function-by-function cross index, showing where each function is used in the model.

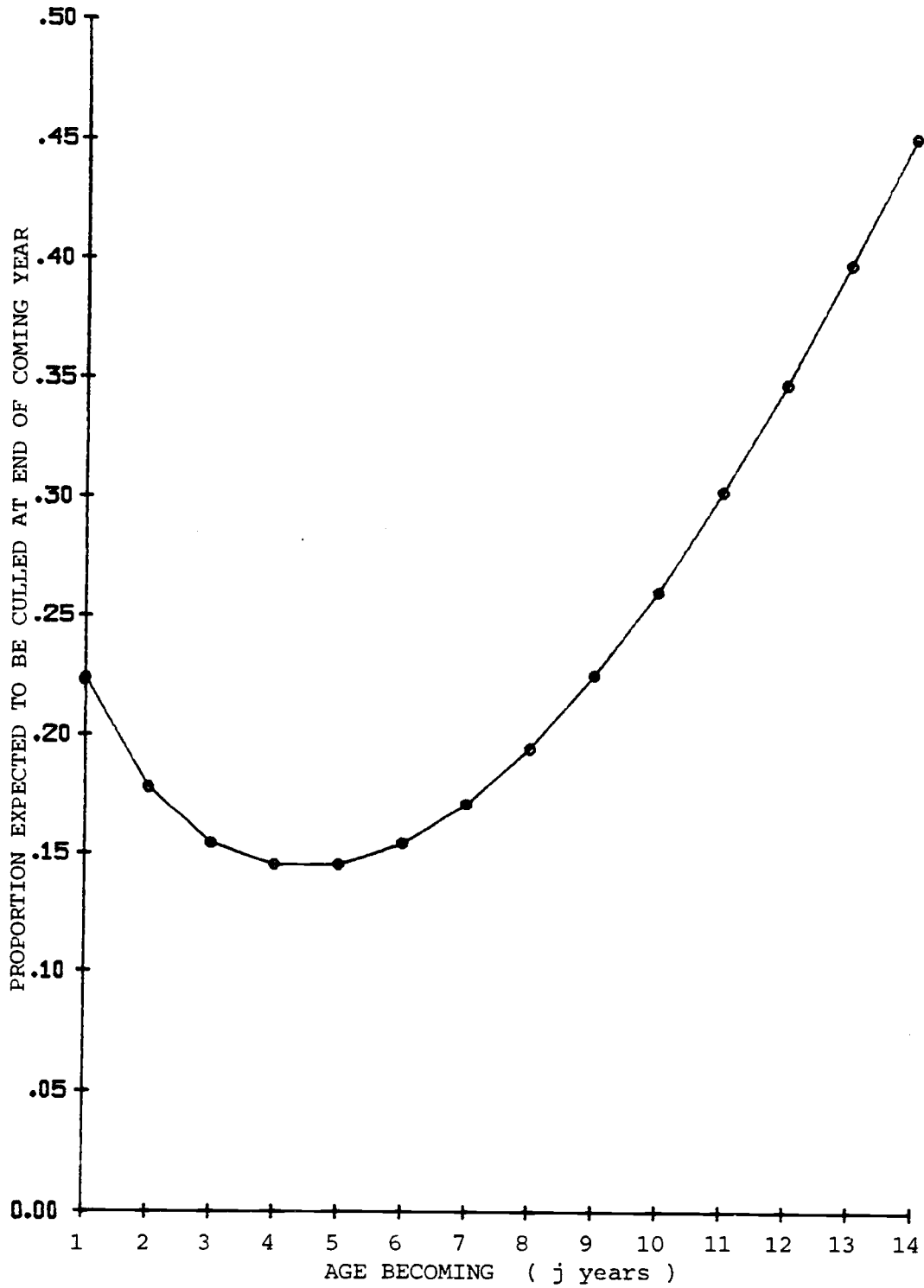
FIGURE 2.8 EXPECTED FRACTIONAL CULLING RATES BY COW AGE ($g_{10,j}$)

CHAPTER 3

DRIVING VARIABLES: PRICE AND COST SERIES

The purpose of this chapter is to describe the sources and means of application of historical price and cost data in the present study. It is clear that calf sales and cull cow sales are the chief sources of revenue for commercial beef cow herds. Not immediately clear are the ways in which weaned calf and cull cow values vary by cow age. These questions are examined here. The variable costs of maintaining pregnant and non-pregnant heifers and cows of different age classes are separately budgeted for the year 1978 as a basis for generating cost budgets in each year of the simulation run. Cost differences between years are simulated by multiplying cost indices developed for each of ten cost categories (for each year of the simulated period 1950-1978) times their respective 1978 base-year-budget amounts.

Calf and cull cow prices, with the cost budgets, are used in the model to generate estimates of net annual revenue for each age heifer and cow (from one to 14 years old) in pregnant and non-pregnant classes in each of the 29 years of simulated time. These net annual revenue values, in turn, are used as part of the basis for generating breeding value measures projected to the future for animals of each age and pregnancy class.

Calf and Cull Cow Prices

Annual average per cwt. prices of Choice feeder steers (600 to 700 pounds at Kansas City) comprise the Z_1 input series for the simulation model. The Z_2 input series is the annual average Utility cow price per cwt. (at Omaha). Both of these price series run from 1950 to 1978, and are listed at the end of this chapter in Table 3.6. They are found in a U.S.D.A. data file (U.S.D.A., E.S.S., T-DAM, 1979), under the variable names "STEPMFEKC6" and "CATPFNF", respectively. The "T-DAM" data file was compiled and updated by the U.S.D.A. for use in large econometric forecasting models (see: Tiegen, 1977; and, Yanagida and Conway, 1980). That file is the source of several other national historical series used in this study.

It is important to note that neither of these input series (Z_1 and Z_2) is applied directly in the value calculations of any class of cows or heifers in the model. Price transformations based on calf gender and cow age occur in a number of functions (g_{13} , g_{14} and g_{25}).

It is assumed in this model that differences in future calf sales values per head across cow ages are due only to differences in calf weights. In other words, the same expected future calf price per cwt. will apply to calves from cows of all ages in a given year.

In estimating future weaned calf sales revenues for cows which are currently pregnant, it is appropriate to use weaning weights representing the average of those expected for steer and heifer calves, by cow age (see discussion of the calf weaning weight function, $g_{6,j}$, in Chapter 2). Likewise, a price representing the average expected for steers

and heifers ought to be projected for these yet unborn sources of potential revenue.

Heifers commonly fetch a lower price per cwt. than steers at all stages, from weaning to slaughter (Ensminger, 1976, p. 1357). In the budget generation equations described in Chapter 4, present salvage opportunity values of weaned heifers kept for breeding are based on prices per cwt. assumed to be 86 percent ($b_{39} = .86$) of those for feeder steers, Z_1 (see Rogers, 1972, p. 922, for similar weighting). Consistent with this assumption, average future calf sales prices are taken to be 93 percent ($b_{38} = .93$) of expected future feeder steer prices ($g_{12,1}$). The 93 percent figure is based on the assumption that half of the calves weaned will be heifers and their price per cwt. will be 86 percent of that for steers.

Normally, some variable proportion of the heifers are kept for breeding and not sold at weaning. However, the model calculations of a cow's value for retainment in the breeding herd anticipate the sale of all calves she will likely wean in the future. Planning horizon limits for these calculations are discussed in Chapter 4.

In the present model, cull cow sales values are taken to be the products of cull cow body weights and cull cow prices per cwt. Body weights are given as a function of cow age only ($g_{4,j}$) while cull cow prices per cwt. are modeled as a function of feeder steer and Utility cow prices as well as cow age. We may safely presume the aggregate population of cull cows going to slaughter in the U.S. is comprised of cows of all age classes, from two to 14 or more years.

It is also safe to assume that cull cow prices per unit of weight are a monotonic decreasing function of age. Burke (1954, p. 6) noted that younger cows tend to be in "better flesh" at culling than older cows, while Burlakov and Startsev (1961, p. 376) likewise stated that the carcasses of older cows are of "poorer quality" than those of middle-aged cows. Koger (1967, p. 242), in a budget analysis of culling practices, assumed culling prices per unit of weight for younger non-pregnant cows to be 25 percent higher than those culled for old age. Rogers (1971, p. 2) wrote that "there is general agreement that the market value of cows decreases with advancing age", noting further that "no published data are available to indicate the nature of this relationship".

Rogers (1971 p.2) assumed that cull cow values (implicitly price times weight) decline with age according to the pattern of a sum-of-the-years-digits accelerated depreciation system. With cull value in units of dollars per head on the vertical axis this pattern is convex to the horizontal age axis.

Bentley, Waters and Shumway (1976, pp. 13-18) tried three alternative cull cow price patterns in their analysis of replacement policies. Their initial alternative assumed the sale of all heifers failing to produce a calf at two years of age (at 950 pounds, after a fattening period, for Good-Choice grade heifer prices), while all other (older) cows would fetch Utility grade prices at a common weight of 1000 pounds. Their other two alternatives assumed linearly declining cull prices over the life of the cow "in an attempt to account for deterioration in carcass quality with age" (p. 17). The first of these was a decline "from the average Good-Choice slaughter heifers and Utility cow prices after the

first calf to Cutter prices after the 14th calf". The second of their linear decline alternatives ranged only from Utility cow prices down to Cutter cow prices (p. 17).

In a discussion of relative salvage values of bred yearling heifers and mature cows, Stonaker (1958 pp. 16, 17) examined the Denver market prices for the second week of November over a 10 year period (1947-1956). He found the mean ratios of Utility grade cow prices (per cwt.) to those for Good to Choice yearling feeder heifers ranged from .6 to .65. Stonaker suggested that a 1000 pound cow leaving the herd would have a salvage value just sufficient to pay for replacing her with a 650 pound bred yearling heifer. Implicit in that suggestion is the questionable assumption that a pregnant yearling heifer could be purchased at her salvage value rather than her value as a breeding animal.

Trapp and King (1979, pp. 4,5) assumed a pattern of relative price declines with cow age, which they attributed to Rogers (1971.) As with the cull value pattern Rogers used, the cull price pattern of Trapp and King has the characteristic of discontinuity at the age of 10 years. That is, cull cow prices were assumed to decrease at a decreasing rate with age until the age of 10 beyond which they remained constant at exactly the level of the Cutter-Canner prices.

As in Bently, Waters and Shumway's study (1976), Trapp and King explicitly separated the weight and price components of cull cow value. The approach of separating the weight and price components of cull cow value is also used in the present study. Here, however, these components are derived as point estimates from continuous functions of cow age.

A Cull Cow Price Function

Yearling heifers, almost 2 years old (and weighing over 700 pounds) at the time of potential cull sale, are assumed in the present model to have cull prices always above those of the older cows and always below those of lighter feeder calves. The cull price of older cows is assumed to fall at first rapidly then progressively slower with advancing age, monotonically decreasing. The most elderly cows, by this process, will have the lowest price per unit of weight and this will be somewhat below Utility grade cow prices, in the neighborhood of the lower grade Canners and Cutters. The latter represent the lowest quality grade of slaughter cattle (McCoy, 1972, pp. 278, 279).

A recent study by Reeves (1980, p. 244) noted serious multicollinearity problems when using both feeder cattle prices and non-fed beef prices as independent variables in the estimation of slaughter cow beef production. Linear regression analysis by the author confirms a high level of correlation between feeder steer prices (Z_1) and Utility cow prices (Z_2) over the study period (1950-1978).

$$Z_2 = -1.8315 + 0.6724 Z_1 \quad R^2 = .9789$$

In general agreement with Stonaker's figures cited above (1978, pp. 16, 17), this equation indicates that Utility cow prices have been somewhat less than 67.2 percent of feeder steer prices on a per unit weight basis. Estimated over a shorter period (1950-1975) the mean annual ratio of Utility cow prices to Canner and Cutter cow prices was 1.08, with a standard deviation of only 0.037. However, over the shorter period (1958-1975) a somewhat smaller ratio (1.059), and standard deviation (0.0175) is noted.

For the purpose of this study, the assumption of a continuous pattern of cull cow price decline with age seems most appropriate. The reason, as with the biological parameters described in the previous chapter, is that there is no a priori justification for the assumption of discontinuous price patterns in so large a population as the number of beef cows sold for slaughter in the U.S.

The present study requires estimates of cull cow prices for each age of cow in each of the 29 years of a simulation run. The following function provides the desired characteristics.

$$\text{Cow } P_j = Z_1 - b_{40}(Z_1 - Z_2) + \frac{b_{40}(Z_1 - Z_2)}{j \cdot b_{41}}$$

where: Cow P_j = current estimate of price per cwt. for a cow if culled just before becoming j years of age, $j = 2$ to 15

Z_1 = current feeder steer price per cwt.

Z_2 = current Utility cow price per cwt.

b_{40} = price spread factor (set at 1.2 initially)

b_{41} = hyperbolic age coefficient (set at 1.0 initially)

Alternative values of the parameters (b_{40} and b_{41}) are discussed in Chapter 4.

This cull cow price model uses the feeder steer-Utility cow prices spread to scale the range of estimates each year, tracing a hyperbolic decline in cull cow price with age. Cull price estimates derived for 1950 and 1978 are plotted in Figure 3.1. The use of the feeder calf prices in this case is justified on the grounds that they are highly but not perfectly correlated with Utility cow prices. The youngest cull cow age class (becoming 2 years old) will fetch prices closer to the feeder calf prices than Utility cow prices. It is argued here that a greater

FIGURE 3.1 CULL COW PRICE ESTIMATES BY COW AGE

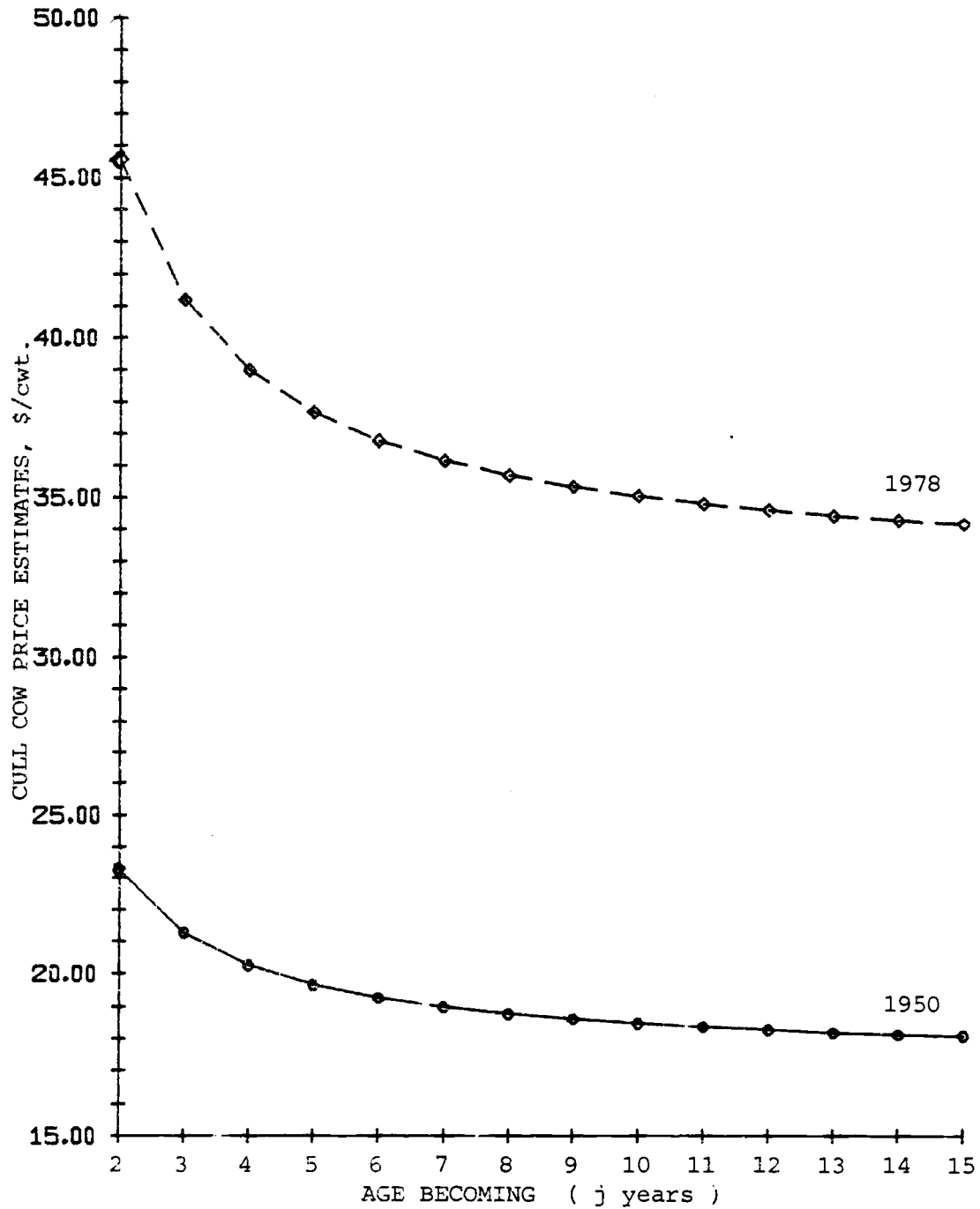

(smaller) than average relative price spread between feeder calf prices and Utility cow prices will be associated with a greater (smaller) relative price spread between the youngest and oldest cull cow age classes. The equation above very simply accomplishes such relative scaling of cull cow prices in each year of the simulation run.

Taking the cull cow price estimates (Cow P_j) in a given year times the respective cull cow weights ($g_{4,j}$, developed in the preceding chapter) results in estimates of present salvage value (PSV) for each age of cow that year. These values are computed in function $g_{14,j}$ of the simulation model. A smooth pattern of cull cow PSV's, concave to the horizontal age axis, is the result. The age at which maximum PSV occurs is a function of the assumed proportions of early and late maturing cow breeds in the national herd as well as the parameters in the cull cow price model described above. The simulation model compares the estimated PSV's with estimated values for breeding in order to make culling and recruitment decisions.

An alternative form of the Cow P_j function is developed in Chapter 4. It uses expected future prices of feeder steers and Utility cows ($g_{12,1}$ and $g_{12,2}$, respectively) in place of the current prices, Z_1 and Z_2 . That function ($g_{13,j}$) generates expected future cull salvage values (FSV $_j$) analogous to the present salvage values ($g_{14,j} = \text{PSV}_j$).

Beef Breeding Animal Maintenance Cost Budgets

Annual maintenance cost budgets are developed in this section for each of five distinct classes of animals in a beef breeding herd:

(1) weaned heifers kept for breeding; (2) pregnant and (3) non-pregnant

yearling heifers (becoming 2 year olds); (4) pregnant and (5) non-pregnant mature cows (becoming 3 years old and over). The cost budgets here are generally based on a herd budget for 1978 estimated for the Great Plains region of the U.S. by the Economics, Statistics and Cooperatives Service of the U.S.D.A. (1979, p. 44), hereafter referred to as the E.S.C.S. herd budget. The herd budget showed cash and non-cash direct costs, ownership costs and other costs on a per-cow and heifer basis. Thus, for the purpose of this study, it was necessary to decompose the E.S.C.S. herd budget to its assumed constituent classes of breeding animals. Of interest here are only the costs which vary with animal numbers, not those which are tied to interest and taxes on land investment or to management costs.

The use of the Great Plains cost data is justified because that region maintains the largest number of beef cows, and has long held that position. It can also be argued that it is more reasonable to assume constant technology within a region than across regions which through time have comprised changing proportions of the national cow herd. It is assumed that net revenues for cows in other regions are highly correlated with those for cows in the Great Plains region.

The cost indexing method used in this study explicitly assumes constant physical proportions of inputs for each class of animals, with only the cost per unit of input changing through time. The 1978 base year budgets developed in this section in effect define the physical proportions of inputs, class by class. Budgets for any particular year of the simulation run are created by applying that year's vector of cost indices (1978 = 1.0) to the base year budgets.

The three sections which follow describe the feed, husbandry and common cost parameters for each class of animal. These are later combined in the simulation model as the 1978 base year cost budgets, to be used with the yearly input cost index vectors. This chapter is concluded with a description of the sources and applications of the historical cost series which comprise the annual cost index vectors.

Feed Costs

Feed cost allocations were based on "animal unit" assumptions as well as assumptions on the age composition of the herd budgeted by the E.S.C.S. From the E.S.C.S. text (1979, pp. 11, 12) it is clear that the per-cow budget assumes 17 bred yearling heifers and 83 cows per 100 cows and heifers in the herd. In order to have 17 bred heifers each year per 83 cows, it is safely assumed that 20 weaned heifers would have to be kept for breeding (allowing for reasonable conception and survival rates for that class). Thus, the budgeted herd is comprised of 83 cows, 17 bred yearling heifers and 20 weaned heifers kept for breeding per "100 cows and heifers".

According to Ensminger (1976, p. 1502) cows and heifers at different levels of maturity can be expected to consume certain quantities of range forage and other feeds. An animal unit month (A.U.M.) is defined as the forage required to support a cow for one month, with or without an unweaned calf at her side, or a heifer 2 years old or older. Young cattle, 1 to 2 years old are supposed to require 0.8 animal units per month while weaned calves to yearlings require only 0.6 animal units per

month. These definitions may be used for estimating the gross feed budgets for the annual time calendar (weaning to weaning) used in this study, though their use has come under justifiable criticism in range-land allocations.

Mature cows are assumed to require feed equivalent to an animal unit year, while the annual budgets for yearling heifers and heifers kept for breeding require further assumptions. Taking the annual feed required for a growing heifer kept for breeding to be comprised of $1/4$ that of a "weaned calf to yearling" class and $3/4$ that of the "young cattle" class, gives 0.75 animal units for the annual average $((1/4)(.6) + (3/4)(.8))$. Similarly, taking the annual feed required for a yearling heifer (becoming 2 years old) to be comprised of $1/4$ that of the "young cattle" class and $3/4$ that of the "mature cow" class we have 0.95 animal units for the annual average $((1/4)(.8) + (3/4)(1))$.

The feed costs from the E.S.C.S. herd budget are decomposed here by allocation factors derived from the above herd composition and the animal unit data. Table 3.1 shows that the sum of the products of animal class numbers per "100 cows and heifers", and their respective "animal unit" requirement per head, equals 114.15 animal unit years for the herd. The feed cost allocation factor for each class of females is derived by dividing their respective number of animal units by this sum of products.

The relevant feed costs (i.e., variable non-land) from the E.S.C.S. (1979, p. 44) budget were multiplied by 100 to derive the herd feed costs shown in Table 3.2. The feed cost allocation factors from Table 3.1 are used in Table 3.2 to estimate the 1978 feed costs attributed to each of the three maturity classes in a herd of "100 cows and heifers".

TABLE 3.1 FEED COST ALLOCATION FACTORS

<u>Herd Composition per "100 Cows & Heifers"</u>		<u>Animal Units per Head</u>	=	<u>Animal Units</u>
83 cows (3 years old and over)	X	1.0	=	83.00
17 yearling heifers (becoming 2 years old)	X	0.95	=	16.15
20 weaned heifers (kept for breeding)	X	0.75	=	15.00
				<hr/>
		A.U.Y. Sum of Products	=	114.15

Feed Cost Allocation Factors

$83.00/114.15 = 0.7271$ for the herd's cows

$16.15/114.15 = 0.1415$ for the herd's 2 year old heifers

$15.00/114.15 = 0.1314$ for the herd's weaned heifers kept for breeding

TABLE 3.2 DECOMPOSITION OF HERD FEED COSTS, GREAT PLAINS, 1978

Feed Category	100 Cows and Heifers			
	1978 Herd Total a/	83 mature cows Allocation Factor (0.7271) b/	17 2-year old heifers Allocation Factor (0.1415) b/	20 weaned heifers Allocation Factor (0.1314) b/
Rented Pasture	\$1,021.00	\$ 742.37	\$144.47	\$134.16
Hay	3,682.00	2,677.00	521.00	483.81
Grain, Concentrate & Silage	712.00	517.69	100.75	93.56
Protein Supplement	48.00	34.90	6.79	6.30
Salt & Minerals	244.00	177.41	34.52	32.06
TOTALS (1978)	\$5,707.00	\$4,149.37	\$807.53	\$749.89

a/ Based on E.S.C.S. Costs of Producing Feeder Cattle in the U.S., U.S.D.A., 1979, p. 44.

b/ Cost allocation factors derived in Table 3.1.

TABLE 3.3 FEED COSTS PER HEAD, BASE YEAR BUDGET PARAMETERS, GREAT PLAINS, 1978 a/

<u>Feed Category</u>	<u>Cows</u>		<u>Weaned Heifers kept for breeding</u>
	<u>(3 years and older)</u>	<u>2 year old heifers</u>	
Rented Pasture	$b_{64} = \$ 8.94$	$b_{55} = \$ 8.50$	$b_{48} = \$ 6.71$
Hay	$b_{65} = 32.25$	$b_{56} = 30.65$	$b_{49} = 24.19$
Grain, Concentrate & Silage	$b_{66} = 6.24$	$b_{57} = 5.93$	$b_{50} = 4.68$
Protein Supplement	$b_{67} = .42$	$b_{58} = .40$	$b_{51} = .32$
Salt & Minerals	$b_{68} = 2.14$	$b_{59} = 2.03$	$b_{52} = 1.60$
TOTALS	\$49.99	\$47.51	\$37.50

a/ Derived from Table 3.2. Parameter Names (b_i) used in the simulation model are shown with their respective values.

Feed costs for 1978 were calculated on a per-head basis for each of the three maturity classes by dividing the class totals in Table 3.2 by the numbers of animals in each class. These per-head costs (shown in Table 3.3) are considered to be the base year feed budget parameters in the simulation model. The parameters names (b_i) are shown with their respective values.

Pregnant or lactating animals may sometimes be given preferential feed treatment in addition to the extra labor and veterinary care normally called for. However, in the present model, it is assumed that pregnant and non-pregnant heifers becoming 2 years old during the year will have the same feed costs. A similar assumption is made in the case of pregnant and non-pregnant cows. Adequate nutritional levels are required by the non-pregnant animals in order to achieve normal conception rates for their age classes.

Husbandry costs

Labor and veterinary care are the cost items which most dramatically distinguish the pregnant animals from their non-pregnant cohorts. These are defined as husbandry costs here. The E.S.C.S. budget categories for labor, veterinary and medicine may be distributed over the three maturity classes according to the numerical compositions used above in combination with some reasonable assumptions regarding intensity of care.

Of 120 females retained for breeding in the budget for "100 cows and heifers", it is assumed that 83 are cows (three years old and over), 17 are heifers (2 years old) and 20 are weaned heifers to be bred at 1 year of age. Thus, the numerical composition of the herd's three

maturity classes is (83/120), (17/120) and (20/120), respectively. It is assumed that most of the mature cows and 2 year old heifers in the E.S.C.S. herd budget would be pregnant at the beginning of the production year (after culling). At that time, of course, none of the weaned heifers would be expected to calve until more than a year in the future.

It is also assumed that the pregnant cows would require labor and veterinary care only slightly in excess of their numerical standing in the herd; say, (85/120) of the herd's requirements. The pregnant heifers (to calve as 2 year olds) however, may be expected to incur such husbandry costs in considerable excess of their numerical standing; say, (25/120) of the herd's requirements. The weaned heifers kept for breeding are expected to require relatively the least amount of attention and veterinary care of all. Their share of the herd's husbandry costs are, therefore, assumed to be only (10/120); that is, a proportion equivalent to one-half their numerical standing in the herd.

The allocation factors of (85/120), (25/120) and (10/120), for the cows, 2 year olds and weaned heifers, respectively, are used in Table 3.4 to decompose the herd's husbandry costs. In the same Table these costs are also calculated on a per-head basis as parameters for use in the simulation model.

The class of weaned heifers kept for breeding is unique in that all these animals begin the year in a non-pregnant state with the prospect of rapid growth and a fair chance of being pregnant at the year's end with little need for labor or veterinary care. In contrast are the cow and 2 year old heifer classes. Pregnant cows and pregnant 2 year old heifers are assumed to have had the prospects of incurring labor and

TABLE 3.4 HUSBANDRY COSTS, BASE YEAR BUDGET PARAMETERS, GREAT PLAINS, 1978 a/

Husbandry cost category	1978 Herd Totals	83 Mature Cows		17 Two Year Olds		20 Weaned Heifers	
		Allocation Factor in herd: (85/120)	Cost per Head <u>b/</u>	Allocation Factor in herd: (25/120)	Cost per Head <u>b/</u>	Allocation Factor in herd: (10/120)	Cost per Head <u>b/</u>
Labor	\$3,227	\$2,285.79	$b_{69} = \$27.54$	\$672.29	$b_{60} = \$39.54$	\$268.91	$b_{53} = \$13.45$
Veterinary and Medicine	392	277.67	$b_{70} = 3.35$	81.67	$b_{61} = 4.80$	32.66	$b_{54} = 1.63$
TOTALS (1978)	\$3,619	\$2,563.46	\$30.89	\$753.96	\$44.34	\$301.57	\$15.08

a/ Based on E.S.C.S. Costs of Producing Feeder Cattle in the U.S., U.S.D.A., 1979, p. 44.

b/ Parameter names (b_i) used in the simulation model are shown with their respective values.

veterinary costs as shown in Table 3.4 for 1978. Non-pregnant cows and non-pregnant two year old heifers, however, are assumed to have had the prospect of requiring far less labor and veterinary care than their pregnant age cohorts. It is assumed that these non-pregnant classes would have had the same minimal husbandry requirements as the younger weaned heifers kept for breeding. Thus, the labor and veterinary base year budget parameters for non-pregnant cows (b_{71} and b_{72}) and non-pregnant two year old heifers (b_{62} and b_{63}) have the same 1978 dollar values as those shown in Table 3.4 for weaned heifers (b_{53} and b_{54} , respectively).

Common Costs

In contrast to the feed and husbandry costs, which vary across cow and heifer maturity or pregnancy classes, are several cost categories assumed to accrue equally to all breeding females on a per head basis. These are: (1) bull depreciation; (2) marketing and hauling costs; (3) fuel, lubrication and electricity; and (4) machinery and building repair.

Bulls are essential to most commercial beef cow/calf enterprises, and the practical concern with proper breeding management is very important to herd managers. However, the attention bulls are given in the present study is slight; that is, only in proportion to their small contribution to operating costs of the female classes.

Bull depreciation costs are treated here as common variable cash operating expenses, at \$10.00 per head in 1978, across all five breeding female classes. This charge is based on the following assumptions: \$1,000.00 bull purchase price; \$400.00 bull salvage price; no bull death

TABLE 3.5 COMMON COSTS, BASE YEAR BUDGET PARAMETERS, GREAT PLAINS, 1978

<u>Common Cost Category</u>	<u>Cost per Head (1978) a/</u>
Bull Depreciation	b ₄₇ = \$10.00
Marketing and Hauling	b ₄₄ = 2.83
Fuel, Lubrication and Electricity	b ₄₅ = 6.76
Machinery and Building Repair	b ₄₆ = 9.22

a/ Except for bull depreciation, these costs are based on E.S.C.S. Costs of Producing Feeder Cattle in the U.S., U.S.D.A., 1979, p. 44, Parameter names (b_i) used in the simulation model are shown with their respective values.

losses; three year useful life for bulls; and a common ratio of 20 cows per bull per year. Bull maintenance costs (feed, labor, etc. are assumed to be included in the cow and heifer budgets implicitly. However, only 1/20 of a bull's maintenance cost would accrue to each cow and heifer (roughly \$7.00 per head per year).

The other three common cost categories are assigned in 1978 dollar values according to the E.S.C.S. herd budget under the assumption that a herd of "100 cows and heifers" actually refers to 83 cows, 17 2 year olds and 20 weaned heifers kept for breeding. The figures shown in Table 3.5 for these categories are simply the herd costs divided by 120 head.

Historical Input Cost Series

Base Year (1978) cost budgets were developed in the preceding three sections of this chapter. In this section the historical input cost series (1950-1978) are described in detail. These input cost series are transformed into (1978=1.0) base year indices (Z_1) which, in combination with the series of feeder steer prices (Z_1) and Utility cow prices (Z_2), discussed earlier, are used to drive the simulation model. In each of the 29 years of the simulation run, nominal cost budgets and net revenues are computed for each age and class of heifers and cows.

Here the source of each of the input cost series is defined individually and the rationale for its selection given. One reason for the choice of the years 1950 through 1978 for the present simulation study was the common availability of relevant cost and price series over that period. The cost series are discussed below in the same order that their associated budget categories were developed in the preceding sections.

Pasture Rental

Much of the feed consumed by beef cows has a very low opportunity cost; that is, unless it is scavenged by cows, it would likely not be used at all. The grazing of unimproved native forage on owned plots of non-arable land, and direct grazing of crop residues such as corn stalks, are examples. The costs of these feed sources (except for the labor and fence maintenance required to make use of them) are not counted in the present study. These fall in the excluded categories of land ownership and management costs.

The pasture costs which are properly counted here are those which require direct out-of-pocket outlays for their maintenance, such as seed and fertilizer, roughly in proportion to cow numbers.

Data on cash rents per acre for pasture land in Kansas were selected for indexing pasture rental costs. The official estimates used were provided by the Kansas Crop and Livestock Reporting Service at Topeka, Kansas. That agency reported their source as unspecified issues of the Economic Research Service (U.S.D.A.) publication; Farm Real Estate Market Developments.

Other measures such as state and regional range condition indices were considered and rejected on the basis of poor geographical representation of the greatest numbers of cows in the nation. These are available for the immense arid rangelands of the West which, though chiefly used for cow/calf production, actually account for only a small fraction of the country's cows (Ensminger 1976, pp. 62-67).

The pasture rental rates for each year of the 1950-1978 series were divided by the 1978 rate of \$9.60 per acre to create the Z_6 index series (1978 = 1.0). The series is listed in Table 3.6 at the end of this section.

Hay

Home grown low quality hay and crop residues comprise large portions of Winter diets for beef cows in this country. Prices paid by farmers for "other hay", as reported in various issues of U.S.D.A. Agricultural Statistics, were used for indexing hay costs in the present study.

"Other hay" refers to hay other than alfalfa.

The hay prices reported by the U.S.D.A. are for national averages weighted by quantities sold and prices paid in the various regions. As in the use of pastures, local weather conditions may affect hay prices. Because of its bulk and low value per unit of weight, hay is seldom worth transporting great distances. However, a national average price for a commodity class used chiefly for cattle feed is appropriate in the present application.

It is worth noting here that a legitimate doubt may be raised about the use of a market price for a commodity which, in large measure, is produced and used without ever passing through market channels.

However, fuel, equipment and labor costs associated with cutting, handling and storing home-grown hay are incurred roughly in proportion to cow numbers. Such costs are also reflected in hay prices. As with the pasture costs discussed above, much hay is produced from forage that may otherwise not be used. Ideally, the hay costs considered in this study

would represent only the out-of-pocket cash costs which could be allocated on a per cow basis.

The "other hay" prices for each year of the 1950-1978 series were divided by the 1978 price of \$52.70 per ton to create the Z_7 index series (1978 = 1.0). The hay cost index series is listed in Table 3.6 at the end of this section.

Grain, Concentrate and Silage

Seasonal average corn prices received by farmers in the U.S. were used for indexing the cost of grain, concentrate and silage. If corn itself was not being used on given farms in the role suggested by the cost budgets, it is safe to assume that whatever took its place had a value positively related to the price of corn.

The source of the corn price series used here was a U.S.D.A. computer data file named "CORPF" (U.S.D.A., E.S.S., T-DAM, 1979). The corn prices for each year of the 1950-1978 series were divided by the 1978 price of \$2.11 per bushel to create the Z_8 index series (1978 = 1.0) for grain, concentrate and silage, listed in Table 3.6.

Salt and Minerals

Salt prices paid by farmers were used for indexing salt and mineral costs. The data source, again, was the U.S.D.A.'s Agricultural Statistics. It is assumed here that the mineral price component of the salt and mineral cost category followed the same price pattern as salt through time.

The salt price for each year of the 1950-1978 series was divided by the 1978 price of \$3.89 per cwt. to create the Z_{10} index series (1978 = 1.0) for salt and minerals, also listed in Table 3.6.

Labor

In order to trace labor costs through time, the U.S. Composite Farm Wage Index was used. The source of this index was a U.S.D.A. computer data file named "WRAHFI" (U.S.D.A., E.S.S., T-DAM, 1979). The base year for the Farm Wage Index was 1967 (1967 = 100). The index for each year of the 1950-1978 series was simply divided by that for 1978 (241) to create the Z_{11} index series (1978 = 1.0) for farm labor (see Table 3.6).

The use of the nation-wide composite farm wage level could be questioned on the grounds that much of the labor used in cow/calf enterprises is provided by the family of the owner at slack times during the year when that labor has low opportunity costs. In 1977, nationally, a mere 21 percent of total labor input for cow/calf enterprises was estimated to be hired labor, yet family labor is counted at the average farm wage rate, just as hired labor, in the E.S.C.S. budgets (1978, p. 8).

Medicine and Veterinary Care

No cost series could be found for veterinary care. The consumer price index for human medical care was assumed to be a close substitute. This index was taken from various issues of the U.S.D.A. Agricultural Statistics.

The base year for the medical care C.P.I. was 1967 (1967 = 100). The index for each year of the 1950-1978 series was divided by that for 1978 (219.4) to create the Z_{12} index series (1978 = 1.0) for medicine and veterinary care, listed in Table 3.6.

Marketing and Handling

The labor cost index (Z_{11}) described above is also used for annual budget estimates of marketing and hauling costs. This reflects the assumption that marketing and hauling costs have changed through time at the same rates as the composite U.S. farm wage rate index.

Fuel, Lubrication and Electricity

A consumer price index for fuel and utilities was used for tracing the cost category of fuel, lubrication and electricity. The base year for this C.P.I. was 1967 (index = 1.0). The index for each year of the 1950-1978 series was divided by that for 1978 (2.16) to create the Z_3 index series (1978 = 1.0) for fuel, lubrication and electricity, listed in Table 3.6. The source of the fuel and utilities C.P.I. was a U.S.D.A. computer data file named "PW051" (U.S.D.A., E.S.S., T-DAM, 1979).

Machinery and Building Repairs

A farm machinery price index was found to cover the period from 1950 through 1972. Beyond 1972 a weighted average of two similar indices for "autos and trucks" and for "other machinery" was used to extend the desired series to 1978. The weighting for this splicing process was based on the relative 1972 levels of the three indices (the basis for all

three was 1910-1914 = 100). The index for each year of the 1950-1978 series was divided by that for 1978 (1,213.0) to create the Z_4 index series (1978 = 1.0) for machinery and building repair costs.

The original three series were found in various issues of the U.S.D.A. Agricultural Statistics. The transformed Z_4 series is listed in Table 3.6 at the end of this section.

Bull Depreciation Charges

Slaughter steer prices, for all weights and grades at Omaha, were used for indexing bull depreciation costs. The source of this data was a U.S.D.A. computer data file named "CATPFFD" (U.S.D.A., E.S.S., T-DAM, 1979).

The slaughter steer price for each year of the 1950-1978 series was divided by the 1978 price of \$52.34 to create the Z_5 index series (1978 = 1.0) for bull charges. This series is also listed in Table 3.6 at the end of this section.

Interest Rates

It is convenient at this point to discuss the Production Credit Association (P.C.A.) interest rate which is the final driving variable (Z_{13}) entering the simulation model. The data sources for this interest rate were various issues of the U.S.D.A. Agricultural Statistics. This interest rate is used in the budget generation equations and as an optional influence on the discount rate for present value calculations of the simulation model. Detailed explanations of these uses are given in Chapter 4.

The Z_{13} input series is comprised of the annual average cost of loans by the P.C.A. (in percent/100). It is assumed that these rates represent those which were being charged for short term production loans to farmers for the purchase of the types of variable cost items described above.

Driving Variable Summary

Table 3.6 gives a complete listing of the vectors of driving variables for the simulation model. The Z_{14} variable indicates the year to which each row (vector) of variables applies. It is used as a flag for the execution of certain calculations and in the model's output reports. Table 3.6 summarizes all the exogenous variables discussed in the present chapter, in the dimensions used by the simulation model.

TABLE 3.6 SIMULATION MODEL DRIVING VARIABLES

z_1	z_2	z_3	z_4	z_5	z_6	z_7	z_8	z_9	z_{10}	z_{11}	z_{12}	z_{13}	z_{14}	
29.2500	19.2600	.3520	.2280	.5330	.2090	.5160	.7200	.3790	.3370	.2120	.2450	.0601	1950	
37.0400	24.0300	.3640	.2460	.6530	.2740	.5840	.7870	.4060	.3570	.2370	.2570	.0608	1951	
31.2900	18.5400	.3700	.2540	.5930	.3490	.6510	.7200	.4740	.3650	.2490	.2710	.0633	1952	
21.0600	12.0400	.3840	.2560	.4190	.3390	.6280	.7010	.4050	.3700	.2530	.2800	.0635	1953	
21.2300	11.1100	.3870	.2570	.4330	.3330	.6020	.6780	.4550	.3780	.2490	.2890	.0636	1954	
21.6100	10.9900	.3940	.2570	.4090	.3590	.5830	.6400	.3700	.3830	.2530	.2950	.0592	1955	
19.6700	10.9100	.4040	.2690	.3850	.3700	.5600	.6110	.3430	.3910	.2660	.3060	.0620	1956	
22.7100	13.4000	.4160	.2820	.4220	.4060	.5540	.5260	.3250	.4010	.2740	.3190	.0666	1957	
29.1000	17.8700	.4250	.2940	.4890	.4270	.5350	.5310	.3540	.4060	.2860	.3340	.0672	1958	
29.7600	17.4700	.4340	.3070	.4990	.4220	.5180	.4970	.3610	.4110	.2990	.3480	.0650	1959	
26.3600	15.3100	.4440	.3150	.4640	.3650	.5500	.4740	.3490	.4140	.3070	.3610	.0725	1960	
25.8600	15.6500	.4500	.3220	.4430	.3390	.5560	.5210	.3850	.4190	.3150	.3710	.0661	1961	
27.0000	15.3700	.4500	.3280	.4860	.3850	.5620	.5310	.3940	.4190	.3240	.3810	.0636	1962	
25.7800	14.7300	.4550	.3340	.4340	.4170	.6110	.6110	.5260	.4230	.4240	.3320	.3900	.0630	1963
21.9200	13.2400	.4560	.3410	.4110	.4380	.6070	.5550	.4210	.4240	.3400	.3980	.0647	1964	
24.1200	14.4400	.4550	.3510	.4650	.4640	.6030	.5500	.4240	.4240	.3570	.4080	.0658	1965	
27.4300	17.8300	.4570	.3640	.4830	.5100	.6110	.5880	.4740	.4320	.3900	.4260	.0687	1966	
26.6800	17.2200	.4630	.3810	.4750	.5000	.6130	.4880	.4580	.4370	.4150	.4560	.0729	1967	
27.9200	17.9400	.4690	.3990	.5050	.5360	.5920	.5120	.4560	.4470	.4560	.4840	.0734	1968	
31.7800	20.2900	.4800	.4200	.5590	.5780	.6020	.5500	.4500	.4580	.5020	.5170	.0779	1969	
33.7000	21.3200	.4980	.4430	.5540	.6090	.6260	.6300	.4800	.4830	.5350	.5500	.0898	1970	
34.8700	21.6200	.5320	.4720	.6120	.5940	.6640	.5120	.4850	.5140	.5560	.5850	.0728	1971	
41.4000	25.2100	.5560	.5060	.6780	.6250	.6960	.7440	.5660	.5370	.5930	.6040	.0702	1972	
53.1700	32.8200	.5880	.5410	.8510	.7290	.8370	1.2090	1.1970	.5760	.6510	.6240	.0809	1973	
37.8800	25.5600	.6950	.6130	.8000	.8960	.9890	1.4310	.8800	.6480	.7180	.6790	.0943	1974	
33.9100	21.0900	.7770	.7490	.8520	.9690	1.0650	1.2040	.7580	.7330	.7880	.7610	.0891	1975	
39.4000	25.3100	.8460	.8490	.7470	.8960	1.1610	1.0190	.9150	.7970	.8630	.8420	.0824	1976	
40.1800	25.3200	.9360	.9310	.7710	.9480	1.1440	.9570	1.1030	.9020	.9340	.9230	.0788	1977	
58.7800	36.7800	1.0000	1.0000	1.0000	1.0000	1.0000	1.0000	1.0000	1.0000	1.0000	1.0000	.0883	1978	

z_1 = Feeder steer prices; z_2 = Utility cow prices; z_3 = Fuel, lubrication and electricity index; z_4 = Machinery and building index; z_5 = Bull charges index; z_6 = Pasture rental index; z_7 = Hay index; z_8 = Grain index; z_9 = Protein supplement index; z_{10} = Salt and mineral index; z_{11} = Labor index; z_{12} = Veterinary and medicine index; z_{13} = P.C.A. interest rate; z_{14} = year

CHAPTER 4

THE BEEF COW VALUE AND DEMOGRAPHY MODEL

In this chapter the body of the value and demography simulation model is described in detail. The value model involves price estimations and projections, budget generation, estimation of present values of future incomes, and development of investment decision variables. These investment decision variables link the value model to the demography model.

The demography model simulates changes in beef cow numbers and age structure of the aggregate herd through time (1950-1978) according to biological constraints and changes in economic incentives. The demography model simulates numbers of cattle in four categories which are comparable to objective historical series. These are: (1) beef cows; (2) "replacement" heifers; (3) cull cows; and (4) calves born to beef cows. The comparisons of simulated numbers to the historical series are described in Chapter 5.

The biological parameters ($g_{1,j}$ through $g_{8,j}$) and management expectation parameters ($g_{9,j}$ and $g_{10,j}$), which were defined in Chapter 2, are all used in the value and demography model. The reader may wish to refer back to the detailed function definitions in Chapter 2 or to the concise FLEXFORM summaries in Appendix A.

The cost and price elements developed in Chapter 3, likewise, are all used in the value model. Again, the budget parameters and the annual price and cost series are summarized in Appendix A. For the details of their development, the reader is referred to Chapter 3.

Estimates of present and future cull salvage values are made for each of 15 discrete age classes of heifers and cows in each of the 29 years of a simulation run, by the value model. Considering input costs each year, the value model generates estimates of the ratios of the present value of future opportunities to present opportunities for each of two discrete classes of animals: V_j^P for pregnant animals becoming j years old, $j = 2$ to 14; and V_j^N for non-pregnant animals becoming j years old, $j = 1$ to 13. Annual decisions (based on these V -ratios) in the demography model determine the proportions of the pre-culling inventories of each class to be retained in the herd.

A distinction between the value model and demography model is made only for the purposes of discussion and computational convenience. Though both consider the same age and pregnancy classes, the value model computes budgets and values on a per head basis, while the demography model deals in units of 100,000 head in the national aggregate herd. The annual calculation sequence for the value and demography models form an unbroken chain of equations from g_{12} through g_{43} . For descriptive convenience the first part of this chapter covers the value model (g_{12} through g_{32}) and the second part, the demography model.

The Beef Cow Value Model

Table 4.1 lists the value model functions with brief descriptions of their respective purposes. Their order of presentation in this chapter generally follows the numerical succession shown in Table 4.1.

Table 4.1 VALUE MODEL FUNCTION LIST

$g_{12,1}$	= Expected future feeder steer price
$g_{12,2}$	= Expected future Utility cow price
$g_{13,j}$	= Expected future cull salvage value (FSV _j)
$g_{14,j}$	= Present cull salvage values (PSV _j)
g_{15}	= Interest charge factor
g_{16}	= Costs common to all budgets
g_{17}	= Cost budget for heifers kept for breeding (HKB's)
g_{18}	= Costs common to yearling heifers
g_{19}	= Cost budget for pregnant yearling heifers
g_{20}	= Cost budget for non-pregnant yearling heifers
g_{21}	= Costs common to cows, aged 3 years and over
g_{22}	= Cost budget for pregnant cows
g_{23}	= Cost budget for non-pregnant cows
g_{24}	= Net annual revenues, non-pregnant classes
g_{25}	= Net annual revenue, pregnant classes
g_{26}	= Discount factor for present value calculations
$g_{27,j}$	= Expected final culling age decisions
$g_{28,j}$	= PVB_j^P calculations
$g_{29,j}$	= $FV_j^P = PVB_j^P / FSV_j$ calculations
$g_{30,j}$	= $V_j^P = PVB_j^P / PSV_j$
$g_{31,j}$	= PVB_j^N calculations
$g_{32,j}$	= $V_j^N = PVB_j^N / PSV_j$ calculations

Future and Present Cull Salvage Values

Simple distributed lag systems allow variable weighting of the preceding and current years' prices for both feeder steers and Utility cows. By changing the weighting parameters, the expected price may be specified as a continuation of the most recent 1-year trend or as a weighted average of the previous and current years' prices. The expected prices, so derived, are used in the projection of future revenues from calf and cull cow sales.

Expected feeder steer prices (\$/cwt.):

$$g_{12,1} = b_{73}m_{4,1} + b_{74}z_1$$

where: $M_{4,1}$ = previous year's feeder steer price (\$/cwt.),

z_1 = current year's feeder steer price (\$/cwt.),

b_{73} and b_{74} are distribution parameters.

Expected Utility cow prices (\$/cwt.):

$$g_{12,2} = b_{75}m_{4,2} + b_{76}z_2$$

Where: $M_{4,2}$ = previous year's Utility cow price (\$/cwt.),

z_2 = current year's Utility cow price (\$/cwt.),

and b_{75} and b_{76} are distribution parameters.

Cull salvage values of different aged cows are functions of both cow body weight and price per cwt. Cow body weight, as a function of age ($g_{4,j}$), has been described in detail in Chapter 2. Cull cow prices per cwt. are assumed to be a function of feeder steer prices and Utility cow prices, and of cow age. This relationship was discussed in detail in Chapter 3. In the functions $g_{13,j}$ and $g_{14,j}$, below, cull cow salvage

values on a \$/hd. basis are expressed in terms of expected future prices (as future salvage value, FSV_j), and in terms of current prices (as present salvage value, PSV_j), respectively.

For $j = 1$ to $15 =$ age becoming,

$$g_{13,j} = FSV_j = \begin{cases} g_{12,1} \cdot g_7 \cdot b_{39} & , \text{ if } j = 1 \\ g_{4,j} \left\{ g_{12,1} - b_{40}(g_{12,1} - g_{12,2}) + \frac{b_{40}(g_{12,1} - g_{12,2})}{j \cdot b_{41}} \right\} & , \text{ if } j > 1 \end{cases}$$

and

$$g_{14,j} = PSV_j = \begin{cases} z_1 \cdot g_7 \cdot b_{39} & , \text{ if } j = 1 \\ g_{4,j} \left\{ z_1 - b_{40}(z_1 - z_2) + \frac{b_{40}(z_1 - z_2)}{j \cdot b_{41}} \right\} & , \text{ if } j > 1 \end{cases}$$

where: FSV_j and PSV_j = expected future salvage value and present salvage value, respectively, for animals becoming j years of age at time of cull sale (\$/hd.),

b_{39} = (heifer price/steer price) factor = 0.86,

g_7 = assumed body weight of a weaned heifer kept for breeding (cwt.),

$b_{4,j}$ = assumed body weight of heifers and cows becoming j years of age (cwt.),

$g_{12,1}$ and $g_{12,2}$ = expected future feeder steer and Utility cow prices, respectively, as defined above (\$/cwt.),

z_1 and z_2 = current feeder steer and Utility cow prices, respectively, (\$/cwt.),

b_{40} = scalar on price spread,

b_{41} = age coefficient

For simulation runs in which it is desirable to differentiate the cull prices of cows by age, the author has found that $b_{40} = 1.2$ and $b_{41} = 1.0$ produce an appropriate pattern (see discussion in Chapter 3). An alternative hypothesis, that all culls becoming 2 years old and over receive the Utility cow price, may be expressed by setting $b_{40} = 99999$. The effect of assigning such a large value to b_{41} , of course, is to cause the last term in $g_{13,j}$ and $g_{14,j}$ to practically vanish.

The future and present salvage value estimates are used in the estimation of net annual revenue budgets, in estimation of the present values of future net incomes, and in investment decision variables.

Annual Cost Budget Generator

Most of the assumptions for defining annual feed, husbandry and common cost budgets for five categories of breeding stock were developed in Chapter 3. Below, the simulation format for the generation of cost budgets is presented.

An interest factor for inflating short-term operating costs is computed first. It is assumed that virtually all the cost items included in the budgets are of a type which may be considered as out-of-pocket cash costs. The Production Credit Association annual average cost of loans (z_{13}) is allowed as a basis for changing interest charges through simulated time. In addition, the parameter b_{36} allows the option of using a constant rate through time, either alone or in combination with some fraction (b_{42}) of the variable P.C.A. rate.

$$g_{15} = (1.0 + (b_{42} \cdot z_{13}) + b_{36})^{b_{43}}$$

where: g_{15} = interest factor for inflating short-term operating costs,
 z_{13} = P.C.A. average cost of loans (%/100),
 b_{42} = constant multiplier of the P.C.A. rate,
 b_{36} = optional constant interest rate,
 b_{43} = exponent representing the fraction of a year for which interest charges are assumed to accrue (initially set = 0.5).

With the exception of the concentrated labor demands at calving, marking, and weaning time, and some of the Winter feed costs, most of the cost items considered are incurred gradually through the course of a year. Thus, no serious biases are introduced by assuming interest charges on the full annual budgets for a half year only.

The interest factor g_{15} is used to inflate the annual cost budgets for each of the five classes of breeding animals defined in the previous chapter. These are: (1) weaned heifers kept for breeding; (2) pregnant yearling heifers; (3) non-pregnant yearling heifers; (4) pregnant mature cows; and (5) non-pregnant mature cows. The composition of these annual budgets proceeds from the common elements to the particular.

The four cost items defined (in Chapter 3) as common to all classes of breeding animals are summarized in the annually calculated function, g_{16} .

$$g_{16} = \left\{ \begin{array}{ll} b_{44} \cdot z_{11} & \text{marketing and hauling costs} \\ + b_{45} \cdot z_3 & \text{fuel, lube., and electricity costs} \\ + b_{46} \cdot z_4 & \text{machinery and bldg. repair costs} \\ + b_{47} \cdot z_5 & \text{bull charges} \end{array} \right\}$$

= costs common to all classes.

The "z" terms in g_{16} are annual cost indices (1978 = 1.0) which are exogenous inputs to the model. The budgeted 1978 common costs (in \$/hd.) are represented by the "b" parameters. The common cost summary (g_{16}) is first used in computing the annual per head cost budget (g_{17}) for a weaned heifer kept for breeding.

$$g_{17} = \left\{ \begin{array}{ll} g_{16} & \text{common costs} \\ + b_{48} \cdot z_6 & \text{pasture rental costs} \\ + b_{49} \cdot z_7 & \text{purchased hay costs} \\ + b_{50} \cdot z_8 & \text{grain and concentrate costs} \\ + b_{51} \cdot z_9 & \text{protein supplement costs} \\ + b_{52} \cdot z_{10} & \text{salt and mineral costs} \\ + b_{53} \cdot z_{11} & \text{labor costs} \\ + b_{54} \cdot z_{12} & \text{veterinary and medicine costs} \\ \cdot g_{15} & \text{short-term interest factor} \end{array} \right.$$

= annual cost budget for weaned heifers kept for breeding (\$/hd.).

The "z" terms are annual input variables (cost indices, 1978 = 1.0), while the "b" terms are the 1978 budget levels for keeping weaned heifers for breeding.

Next, the costs common to pregnant and non-pregnant yearling heifers are calculated.

$$g_{18} = \left\{ \begin{array}{ll} b_{55} \cdot z_6 & \text{pasture rental costs} \\ + b_{56} \cdot z_7 & \text{purchased hay costs} \\ + b_{57} \cdot z_8 & \text{grain and concentrate costs} \\ + b_{58} \cdot z_9 & \text{protein supplement costs} \\ + b_{59} \cdot z_{10} & \text{salt mineral costs} \end{array} \right.$$

= costs common to yearling heifers, pregnant or not.

Here again the "z" terms are annual input variables (cost indices, 1978 = 1.0), and the "b" terms are the 1978 budget levels calculated in Chapter 3. The amount, in \$/hd., computed by the g_{18} function becomes part of the next two functions. These are for computing annual cost budgets specific to pregnant yearling heifers and to non-pregnant yearling heifers.

$$g_{19} = \left\{ \begin{array}{l} g_{16} + g_{18} \\ + b_{60} \cdot z_{11} \\ + b_{61} \cdot z_{12} \\ \cdot g_{15} \end{array} \right\}$$

common costs
labor costs
veterinary and medicine costs
short-term interest factor

= annual cost budget for pregnant yearling heifers.

The budget for non-pregnant yearling heifers differs from the above function only in the cost parameters for labor, veterinary care and medicine. Considerable labor requirements are associated with first-calving heifers.

$$g_{20} = \left\{ \begin{array}{l} g_{16} + g_{18} \\ + b_{62} \cdot z_{11} \\ + b_{63} \cdot z_{12} \\ \cdot g_{15} \end{array} \right\}$$

common costs
labor costs
veterinary and medicine costs
short-term interest factor

= annual cost budget for non-pregnant yearling heifers.

Both the g_{19} and g_{20} budgets are given in units of \$/hd. As usual, the "z" terms are annual input variables (cost indices, 1978 = 1.0), while the "b" terms are the respective 1978 budget values.

The costs common to all cows becoming 3 years old and over, whether pregnant or not, are now computed in g_{21} .

$$g_{21} = \left\{ \begin{array}{l} b_{64} \cdot z_6 \\ + b_{65} \cdot z_7 \\ + b_{66} \cdot z_8 \\ + b_{67} \cdot z_9 \\ + b_{68} \cdot z_{10} \end{array} \right\}$$

pasture rental costs
purchased hay costs
grain and concentrate costs
protein supplement costs
salt and mineral costs

= common costs for cows becoming 3 years old and over, pregnant or not.

Again the annual input variables (cost indices, 1978 = 1.0) are given as the "z" terms above with their respective 1978 budget levels ("b" parameters). The same applies in the final two budgets below. These calculate annual budgets for pregnant and non-pregnant mature cows, respectively.

$$g_{22} = \left\{ \begin{array}{l} g_{16} + g_{21} \\ + b_{69} \cdot z_{11} \\ + b_{70} \cdot z_{12} \end{array} \right\}$$

common costs
labor costs
veterinary and medicine costs
short-term interest factor

= annual cost budget for pregnant mature cows, becoming 3 years old and over.

As in the case of yearling heifers, the budget for non-pregnant mature cows differs from that for their pregnant cohorts only in the cost parameters for labor, veterinary care and medicine. The labor demands associated with calving and subsequent care of the calf account for most of the difference.

$$g_{23} = \left\{ \begin{array}{l} g_{16} + g_{21} \\ + b_{71} \cdot z_{11} \\ + b_{72} \cdot z_{12} \\ \cdot g_{15} \end{array} \right\}$$

common costs

labor costs

veterinary and medicine costs

short-term interest factor

= annual cost budget for non-pregnant mature cows, becoming 3 years old and over.

The annual cost budgets defined above are used next in the calculation of expected net annual revenues for 26 distinct classes of breeding animals: pregnant and non-pregnant heifers and cows, each with 13 age classes.

Expected Net Annual Revenues

Expected calf sales and fractional culling revenues, along with the annual cost budgets developed in the previous section, are used to compute expected net annual revenues. These annual net revenue values are used subsequently in computing estimates of discounted maximum net future income for each of 26 discrete classes of heifers and cows which may be retained in the herd for breeding.

An unusual assumption made in the net annual revenue calculations below is that the annual cost budgets, based on the current year's cost indices, are projected to the indefinite future. In contrast, the revenues expected from calf and cull cow sales are based on expected future prices (see g_{12} and g_{13} definitions above), not simply on the current year's prices. An earlier version of the model projected current calf and cull cow prices to the indefinite future. The poor turning-point tracking of that version suggested a change to the present model structure.

The expected net annual revenues for the non-pregnant yearling heifers and non-pregnant cow classes are computed in the function, $g_{24,j}$. Net annual revenues expected for weaned heifers kept for breeding are computed in the subsequent function ($g_{25,j}$) along with all those for the pregnant cow classes.

The calculation of expected net annual revenues for the non-pregnant classes is simple because no calf sales revenues are anticipated. The only source of revenue for these classes when they are kept for breeding arises from the probability that some fraction of them will be sold as culls one year in the future, either for reasons of impaired health or non-pregnancy. The likelihood of culling an animal next year on such grounds has been defined (in Chapter 2) as a management expectation parameter ($g_{10,j}$). This likelihood, multiplied by the expected future sales value ($g_{13,j}$) of a cow of the appropriate age (becoming $j + 1$ years of age), provides the estimate of fractional cull revenue. Subtracting from this the appropriate annual cost budget results in the estimated annual net revenue for non-pregnant heifers and cows.

For $j = 2$ to $13 =$ age becoming,

$$g_{24,j} = \begin{cases} (g_{10,2} g_{13,3}) - g_{20} & , \text{ if } j = 2 \\ (g_{10,j} g_{13,(j+1)}) - g_{23} & , \text{ if } j > 2 \end{cases}$$

where: $g_{24,2} = \text{NAR}_2^N =$ net annual revenue expected for non-pregnant yearling heifers (becoming 2 years old if kept for breeding) (\$/hd.),

$g_{24,j} = \text{NAR}_j^N =$ net annual revenue expected for non-pregnant cows (becoming j years old if kept for breeding, $j > 2$) (\$/hd.),

$g_{10,j}$ = expected culling rate next year, due to impaired health or non-pregnancy, for heifers and cows presently becoming j years of age,

$g_{13,j}$ = expected future cull salvage value for a cow becoming j years of age at time of sale (\$/hd.),

$g_{20,23}$ = annual cost budgets for yearling heifers and mature cows, respectively (\$/hd.).

The chief feature distinguishing the expected net annual revenues of the pregnant cow classes from those of the non-pregnant classes is the expectation of calf sales revenues. Expected calf sales revenues from pregnant cows vary across cow ages according to differences in calf sales weights and calf survival rates. The likelihood of a pregnant cow (presently becoming j years of age) weaning a calf ($g_{8,j}$), multiplied by the expected calf weaning weight ($g_{6,j}$) and the expected future calf price (\$/cwt. = $g_{12,1} \cdot b_{38}$) determines expected calf sales revenue.

For $j = 1$ to $14 =$ age becoming,

$$g_{25,j} = \begin{cases} (g_{10,1} g_{13,2}) - g_{17} & , \text{ if } j = 1 \\ (g_{10,2} g_{13,3}) - g_{19} + (g_{8,2} g_{6,2} g_{12,1} b_{38}) & , \text{ if } j = 2 \\ (g_{10,j} g_{13,(j+1)}) - g_{22} + (g_{8,j} g_{6,j} g_{12,1} b_{38}) & , \text{ if } j > 2 \end{cases}$$

where: $g_{25,1} = NAR_1^N$ = expected net annual revenue for weaned heifers kept for breeding (\$/hd.),

$g_{25,2} = NAR_2^P$ = expected net annual revenue for pregnant yearling heifers, if retained (\$/hd.),

$g_{25,j} = NAR_j^P$ = expected net annual revenue for pregnant mature cows (becoming j years old if retained, $j > 2$) (\$/hd.),

$g_{8,j}$ and $g_{6,j}$ = calf survival rates and weaning weights, respectively, for cows becoming j years old,

$g_{12,1} \cdot b_{38}$ = expected future calf price (\$/hd.),

g_{17} , g_{19} , g_{22} = annual cost budgets for weaned heifers, pregnant yearling heifers and pregnant mature cows, respectively.

Present Value of Expected Net Future Incomes

Heifer recruitment and cow retainment decisions in the present simulation model are predicated on class by class V-ratios. The V-ratio for a particular age and pregnancy class of heifers or cows is defined here as the ratio of discounted future net income expectations for such a cow (if retained in the herd) to her present cull salvage value, that is, the ratio of future to present income opportunities. Such a measure has a precedent in the cattle investment literature. In their firm-level dynamic optimization study, Trapp and King (1979) considered that the most profitable final culling age for cows (beyond the routine culling for reproductive failure, etc.) may vary between years and would depend on the ratio of discounted future opportunities to present opportunities, by age class. Their productive futures being shorter, the most elderly cows would have the lowest opportunity, or value, ratios. Trapp and King assumed future prices and cost relationships were known with certainty and, on this basis, computed the net income opportunities for cows of each age. The time horizons for these calculations were limited by the age of cow for which the value ratio was less than 1.0. That is, no cows would be kept beyond the age at which they could more profitably be slaughtered.

The present model uses a similar approach in computing expected future net incomes for cows of each age and pregnancy class, though not in an optimization framework, and with future prices and costs only as calculated expectations. Here, estimates of the present value of net future income are computed for pregnant cows; beginning with the oldest age class (becoming 14 years old) and working down through the younger classes. These estimates are referred to as PVB_j^P ; that is "present value for breeding" for pregnant cows becoming j years of age. For each (j) age class of pregnant cows, the V-ratio of PVB_j^P to PSV_j (present cull salvage value) is used later, in the demography model, to determine the proportion of cows in the class which are retained in the breeding herd in a given year of a simulation run. However, in the calculation of PVB_j^P stricter rules are used.

A discount factor is needed in the PVB_j^P calculations to express future years' costs and revenues in terms of current dollars. The discount factor is defined here as the function g_{26} .

$$g_{26} = \frac{1.0}{1.0 + (b_{80} \cdot z_{13}) + b_{37}}$$

where: z_{13} = P.C.A. average cost of loans (%/100), an annual input variable to the model,

b_{80} = a constant scaling factor for z_{13} (initially set at 1.0),

b_{37} = an optional constant discount rate (initially set at zero).

The discount factor (g_{26}) is taken to the power of the i th year of the future in the "present value for breeding" (PVB_j^P) calculations which follow. The P.C.A. interest rate may be usable as an indicator of inter-

mediate term capital opportunity costs through the historical period simulated.

Because an element of expected inflation is implicit in bank loan rates, and because nominal cash costs and prices are used here for projecting future costs and prices, an argument exists for the use of a lower constant discount rate through time. That option is provided by the parameter b_{37} .

In this model, the calculation of PVB_j^P is based on expectations of future prices and performance, as well as some limiting rules. The question of whether a cow retained in the herd for the coming year is expected to be retained again in the subsequent year, is handled by one or more of three rules. The first rule is that all cows are culled before the age of 15 years. Thus, calculations for a cow presently becoming 14 years of age are strictly limited to a one-year horizon, while those for a cow becoming 13 years old are limited to a maximum two-year horizon, and so on.

The second rule is that of an arbitrary optional maximum limit on the planning horizon beyond the first year of the future. A control parameter (b_{81}), provided for this purpose, may be assigned an integer value from 0 to 14. If b_{81} is set at a value of 0 the maximum planning horizon for any age group would be only the first year of the future. If b_{81} is set at a value of 1, the maximum horizon would be 2 years in the future, and so on. Of course, the first rule (on maximum age) still applies.

The third rule limiting the planning horizon in the PVB_j^P calculations for younger cows depends on the FV_j ratio (PVB_j^P / FSV_j^P) of the

older cows, similar to the method used by Trapp and King (1979). FV_j ratios are calculated only for the purpose of defining expected planning horizon limits in the oldest-to-youngest iterative calculation of PVB_j^P in each year of a simulation run. An FV_j ratio less than b_{82} (a parameter initially set at 1.0) would, by the third rule, cause the planning horizon for the PVB_{j-1}^P calculation to be limited to a single year. On the other hand, an FV_j ratio greater than b_{82} would allow the PVB_{j-1}^P calculations to assume the animal would be retained in the herd as a j year old, if not limited to a shorter horizon by one of the other two rules.

The effect of the third rule is a general expectation of culling a cow at the age just beyond which cows appear to be worth more for immediate cull salvage than for retention in the herd. "Expectations" and "apparent worth" are key notions in this model's PVB_j calculations. The expected final culling age of a given class of cows, and their apparent worth as breeding animals, have only an indirect influence on decisions (in the herd demography model) regarding the proportion of the class to be retained in a given year.

A considerable body of literature has evolved on the concepts regarding present value calculations for investments with futures defined in stochastic terms. See for example, Burt (1965), Yotopoulos (1967), Hirshleifer (1970), Perrin (1972), Anderson, et al (1977), Dillon (1977), and Bentley, et al (1976).

The computational algorithm for PVB_j^P involves three basic functions repeated in an iterative series. The operations proceed in the following order:

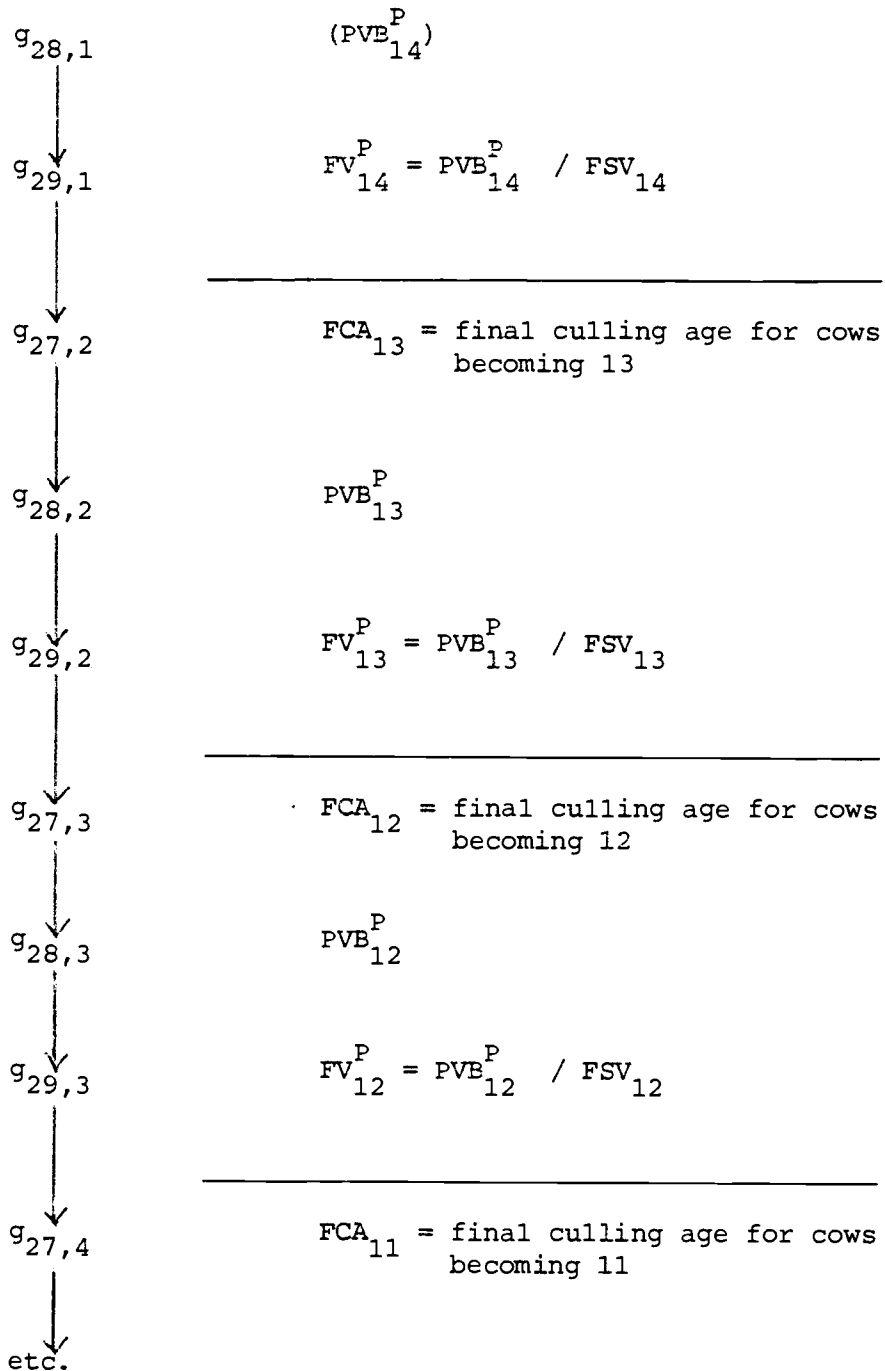

In the three iterative functions ($g_{27,j}$, $g_{28,j}$ and $g_{29,j}$), the second subscript (j) refers to the cow age class; specifically, age becoming = (15- j) years.

The class of pregnant cows becoming 14 years old are a special case in that the planning horizon for them is limited to a maximum of only a

single year, by definition. Calculation of PVB_{14}^P ($g_{28,1}$) begins the iterative chain of calculations.

$$g_{28,1} = \left\{ \underbrace{\left(\frac{g_{9,15}}{g_{9,14}} \right) g_{13,15}}_{\text{expected final culling revenue}} + \underbrace{g_{25,14}}_{NAR_{14}^P} \right\} \cdot \underbrace{g_{26}}_{\text{discount factor}} = PVB_{14}^P$$

The term identified as "final culling revenue" in the equation above is simply the product of the expected future salvage value ($FSV_{15} = g_{13,15}$) of a cow becoming 15 years old when culled, and the likelihood that a cow retained as a pregnant animal becoming 14 years old will be alive, healthy and pregnant when becoming 15 years of age (see Chapter 2 for definition of $g_{9,j}$). By assumption, all cows becoming 15 years old are culled immediately, regardless of their health or pregnancy status. This assumption was made for the sake of computational convenience, but introduces little bias because very few cows (perhaps one percent) survive to this age.

The additive term ($g_{25,14}$) in the PVB_{14}^P equation above is the expected net annual revenue for a pregnant cow becoming 14 years of age (NAR_{14}^P). As defined earlier in this chapter, NAR_j^P ($g_{25,j}$) is computed each year of the simulation run to include expected calf sales and fractional cull sale revenues minus the appropriate annual cost budget estimates. Thus, the expected future disposition of the 14 year old cow is entirely accounted for: if it does not die during the year, it is culled, healthy or not, pregnant or not.

For the pregnant cow becoming 14 years old, the expected final cull sale revenue and the expected net annual revenue are reckoned to occur on

the same date: one year from the time of the present calculation. Therefore, the sum of the two terms is multiplied by the discount factor (g_{26}) to yield an estimate of the present value of future net income for a pregnant cow retained to calve as a 14 year old (PVB_{14}^P). The ratio of this value to the expected future salvage value (FSV_{14}) is computed next in the function $g_{29,1}$ ($= FV_{14}$) for use as a decision variable in determining the expected final culling age (planning horizon limit) for cows becoming 13 years old.

$$g_{29,1} = g_{28,1} / g_{13,14} = FV_{14}^P = PVB_{14}^P / FSV_{14}.$$

The three rules, described in the text above, for limiting the expected planning horizons for the PVB_j^P calculations may be expressed concisely as a conditional equation, $g_{27,j}$ (FCA_j).

For $j = 2$ to 14, (where age becoming = $15 - j$),

$$g_{27,j} = \begin{cases} \min \left\{ 15, (14 + b_{81}) \right\} & , \text{if } j = 2 \text{ and } g_{29,1} \geq b_{82} \\ \min \left\{ g_{27, (j-1)}, (16-j + b_{81}) \right\} & , \text{if } j \geq 2 \text{ and } g_{29, (j-1)} \geq b_{82} \\ (16 - j) & , \text{if } g_{29, (j-1)} < b_{82}. \end{cases}$$

Summarizing the earlier explanation of the variable expected final culling age criteria, it is assumed that: (1) no cows shall be retained in the herd as 15 year olds; (2) a limit (b_{81}) on the length of the planning horizon beyond the first year of a cow's future may be imposed; and (3) culling is planned at an age no older than that at which $FV_j < b_{82}$ (where $b_{82} = 1.0 = \text{critical } PVB_j^P / FSV_j$).

The planned final culling age (FCA_j) for a cow of a given age will be the minimum allowed by the three rules above. For the purposes of

calculating PVB_j^P in a given year of the simulation run, cows of different ages may be expected to have different final culling ages. Furthermore, between years in a simulation run, a given age class of cows (i.e., pregnant 12 year olds) may be assigned different planning horizons, depending on the economic outlook in the particular years.

The PVB_j calculations for pregnant cows becoming 13 years old and under, and for weaned heifers kept for breeding, are carried out in the iterative process described above by a single functional form, $g_{28,j}$. This function has the same type of elements as $g_{28,1}(PVB_{14}^P)$; that is, a summation of discounted expected future net annual incomes and final cull sale revenue. The format is different, however, to allow for the longer potential planning horizons for younger animals. The functional form shown here, in fact, allows up to a 14 year planning horizon for weaned heifers kept for breeding.

For $j = 2$ to 14 (where age becoming = 15-j years)

$$g_{28,j} = \left\{ \left(\frac{g_{9,(g_{27,j})}}{g_{9,(15-j)}} \right) g_{13,(g_{27,j})} \right\} g_{26}^{(g_{27,j}-15+j)} + \sum_{i=1}^{(g_{27,j}-15+j)} \left\{ \left(\frac{g_{9,(14+i-j)}}{g_{9,(15-j)}} \right) g_{25,(14+i-j)} \right\} g_{26}^i$$

} Likelihood that a cow retained as a (15-j) year old will be alive, pregnant and healthy when becoming (g_{27,j}) years old.
} Expected future cull salvage value for a cow becoming (g_{27,j}) years old at culling.
} Discount factor to power of length of planning horizon.

Present value of final cull sales revenue

} Likelihood that a cow retained as a (15-j) year old will be retained in the herd when becoming (14+i-j) years old.
} Expected future net annual revenue for a cow becoming (14+i-j) years old: NAR^P(14+i-j)
} Discount factor to ith power

Present value of the sum of future net annual incomes

$PVB_{(15-j)}^F =$ } }

The PVB_j^P function ($g_{28,j}$) has the most formidable appearance of any in the model, yet has a simple interpretation when considered in its parts. The subscripting scheme allows computation in an iterative loop, proceeding from the oldest to the youngest animals, as described above.

The final step in the iterative process here is calculation of the FV_j ratios (PVB_j^P / FSV_j) for use in the expected final culling age decisions (g_{27}).

For $j = 2$ to 14 (where age becoming = 15 - j),

$$g_{29,j} = g_{28,j} / g_{13,(15-j)} = FV_j \text{ (used in } g_{27,(j+1)}).$$

Decision Variables

The next functional form ($g_{30,j}$) yields the V_j^P ratios (PVB_j^P / PSV_j) which are the key links between the value model and the demography model. These are the ratios of future opportunities to present opportunities for pregnant cows by age classes.

For $j = 2$ to 14 (where $j =$ age becoming),

$$g_{30,j} = g_{28,(15-j)} / g_{14,j} = V_j^P = PVB_j^P / PSV_j.$$

These V-ratios have an interpretation which particularly suits them for use as investment criteria. Any cow (pregnant or not) may be liquidated by immediate sale at the cull salvage value of her age class. This (PSV_j) may be considered as her present value for immediate slaughter (a present and fairly certain opportunity). A pregnant cow obviously has some potential for weaning a calf, which would be sold at the end of the year, and a good chance of surviving herself to be sold or retained, depending on which option appears most profitable. Subtracting the estimated maintenance costs involved in retaining the cow, and discounting

the expected future net revenues back to the present, yields the estimated opportunity value of her retainment (PVB_j). This estimate is unavcidably less certain than that of the cow's present slaughter value.

The comparison of the future to the present opportunities (PVB_j to PSV_j) for a cow representative of a given age and pregnancy class of cows should provide a strong indication of the relative inducements cow owners face in their decisions regarding the disposition of these animals. For example, a V-ratio of less than 1.0 suggests incentives for heavy culling, while a V-ratio of 2.0 suggest very high incentives for retainment.

Another useful feature of the V-ratios defined here is that they provide a common basis for comparison across age classes. They answer the question: for each dollar of present liquid inventory value, how much (in present dollars) will one age class yield in the future versus all other age classes. With a few additional assumptions, described below, V-ratios are computed for the non-pregnant cows. These are directly comparable, in the sense of present liquidity value with those described above for the pregnant cow classes.

The calculation of the present values of future net incomes for the non-pregnant classes (PVB_j^N) differ from those of the pregnant classes only by the discounted net annual incomes for the first year. That is, beyond the first year of their futures, pregnant and non-pregnant cows of the same age are assumed to have the same streams of net annual incomes. The planning horizon limits that apply to the pregnant classes in a given simulation run will also apply to the non-pregnant classes.

The expected net annual income budgets for the non-pregnant and pregnant classes are calculated each year of a simulation run by the functions

$g_{24,j}$ ($= NAR_j^N$) and $g_{25,j}$ ($= NAR_j^P$), which were described earlier in this chapter. The first-year adjustments are carried out in the function $g_{31,j}$ to yield the discounted maximum present values of the expected future net incomes of non-pregnant heifers and cows becoming 2 to 13 years of age (PVB_j^N).

For $j = 2$ to 13 (where $j =$ age becoming),

$$g_{31,j} = g_{28,(15-j)} - \left\{ (g_{25,j} - g_{24,j}) \cdot g_{26,1} \right\}$$

that is, $PVB_j^N = PVB_j^P - (NAR_j^P - NAR_j^N) \cdot \text{discount factor}$

Of course, the main differences in the first-year budgets of the pregnant and non-pregnant classes are due to the expectations of calf sales revenues for the former.

The value model is completed with the following function which calculates the V-ratios for the non-pregnant classes (V_j^N).

For $j = 1$ to 13 (where $j =$ age becoming),

$$g_{32,j} = \begin{cases} g_{28,14} / g_{14,1} & , \text{if } j = 1 \\ g_{31,j} / g_{14,j} & , \text{if } j > 1. \end{cases}$$

The V-ratios for non-pregnant heifers and cows, calculated above, are the basis for the decisions (later, in $g_{38,j}$) on the proportions of animals in these classes to be retained for breeding each year of a simulation run. The V-ratios (PVB_j^N / PSV_j) for non-pregnant animals are directly comparable to those computed for their pregnant age cohorts, having identical denominators; specifically, their present inventory liquidation values (PSV_j).

The case of weaned heifers kept for breeding is distinguished from all other classes. In order to allow consideration of long planning horizons for weaned heifers, their PVB_1^N is computed as the last step ($g_{28,14}$) in the oldest-to-youngest iterative process of PVB_j^P calculations. In that process, the weaned heifers kept for breeding (HKB's) are the only non-pregnant class considered. The computations for all older classes are based on the assumption of current pregnancy. The V_j^N -ratio computations ($g_{32,j}$) for the non-pregnant classes also distinguish the weaned heifers kept for breeding from all older classes using $g_{28,14}$ in the numerator of the former and $g_{31,j}$ in those of the latter.

Synopsis of the Value Model

The description of the value model is now complete and is summarized here. Expected calf and utility cow prices were defined in $g_{12,1}$ and $g_{12,2}$ on a per cwt. basis. Expected future cull values and current cull values were defined on a \$/hd. basis as functions of body weight and price per cwt. (both functions of age) in $g_{13,j}$ and $g_{14,j}$, respectively. Annual cost budgets were defined for five broad classes of breeding animals in the functions g_{15} through g_{23} . Then annual expected net revenue budgets were defined for 26 discrete age and pregnancy classes in the functions $g_{24,j}$ and $g_{25,j}$.

A discount factor (g_{26}) was defined for use in the iterative, oldest-to-youngest, sequence of PVB_j^P calculations. This sequence runs from "expected final culling age" (FCA = g_{27}), to "present value for breeding" (PVB = g_{28}), to "expected future V-ratio" (FV = g_{29}); then repeats for progressively younger classes. The PVB_1^N for weaned heifers kept for

breeding, is the last in this sequence. In this sequence, the planning horizons for present value calculations of future cow incomes are limited by rules which include the assumption that cow retainment will not extend to cow ages beyond which they are expected to be worth more for slaughter than for breeding.

The expected present values of future net incomes ($PVB_j^N = g_{31,j}$) for the non-pregnant classes (other than weaned HKB's) are simply those of their pregnant age cohorts adjusted for the differences in their first year's expected net annual revenues. There is no expectation of calf sales revenues from any of the non-pregnant classes until 2 years in their future. The calculation of V_j^N -ratios ($g_{32,j}$) for the non-pregnant classes completes the value model. These, along with the V_j^P -ratios ($g_{30,j}$) computed for the pregnant classes, provide the major links between the value model and the beef cow demography model described below.

Beef Cow Demography Model

A simple method is developed to account for the numbers of beef heifers and cows in each age and pregnancy class through simulated time. The functions specific to the demography model are listed in Table 4.2 and shown in a flowchart by Figure 4.1. Each year of a simulation run begins with a post culling age structure; that is, the numbers of heifers and cows in each class which are retained in the herd after culling. The number of animals in the beginning inventory of each class are carried by the model as state variables, $x_{1,j}$ and $x_{2,j}$.

Calving, rebreeding, and natural deaths, are assumed to occur during a simulated year. The functions $g_{34,j}$ and $g_{35,j}$ are specified to compute

TABLE 4.2 DEMOGRAPHY MODEL FUNCTION LIST

STATE VARIABLES

- $x_{1,1}$ = Weaned heifers not kept for breeding
- $x_{1,j}$ = Post-culling inventories of pregnant cows ($j = 2$ to 14)
- $x_{2,j}$ = Post-culling inventories, non-pregnant heifers and cows
($j = 1$ to 13)

INTERMEDIATE FUNCTIONS

- $g_{34,j}$ = Pre-culling inventories of pregnant animals
- $g_{35,j}$ = Pre-culling inventories of non-pregnant animals
- $g_{37,j}$ = Proportions of pregnant animals to be retained
- $g_{38,j}$ = Proportions of non-pregnant animals to be retained
- $g_{39,j}$ = Numbers of pregnant animals to be retained
- $g_{40,j}$ = Numbers of non-pregnant animals to be retained
- $g_{41,j}$ = Numbers of pregnant animals to cull
- $g_{42,j}$ = Numbers of non-pregnant animals to cull
- $g_{43,j}$ = Summations for output reports

FLUX FUNCTIONS (Updating State Variables)

$$f_{1,j} = \Delta x_{1,j} \quad \text{and} \quad f_{2,j} = \Delta x_{2,j}$$

Figure 4.1 BEEF COW DEMOGRAPHY FLOWCHART

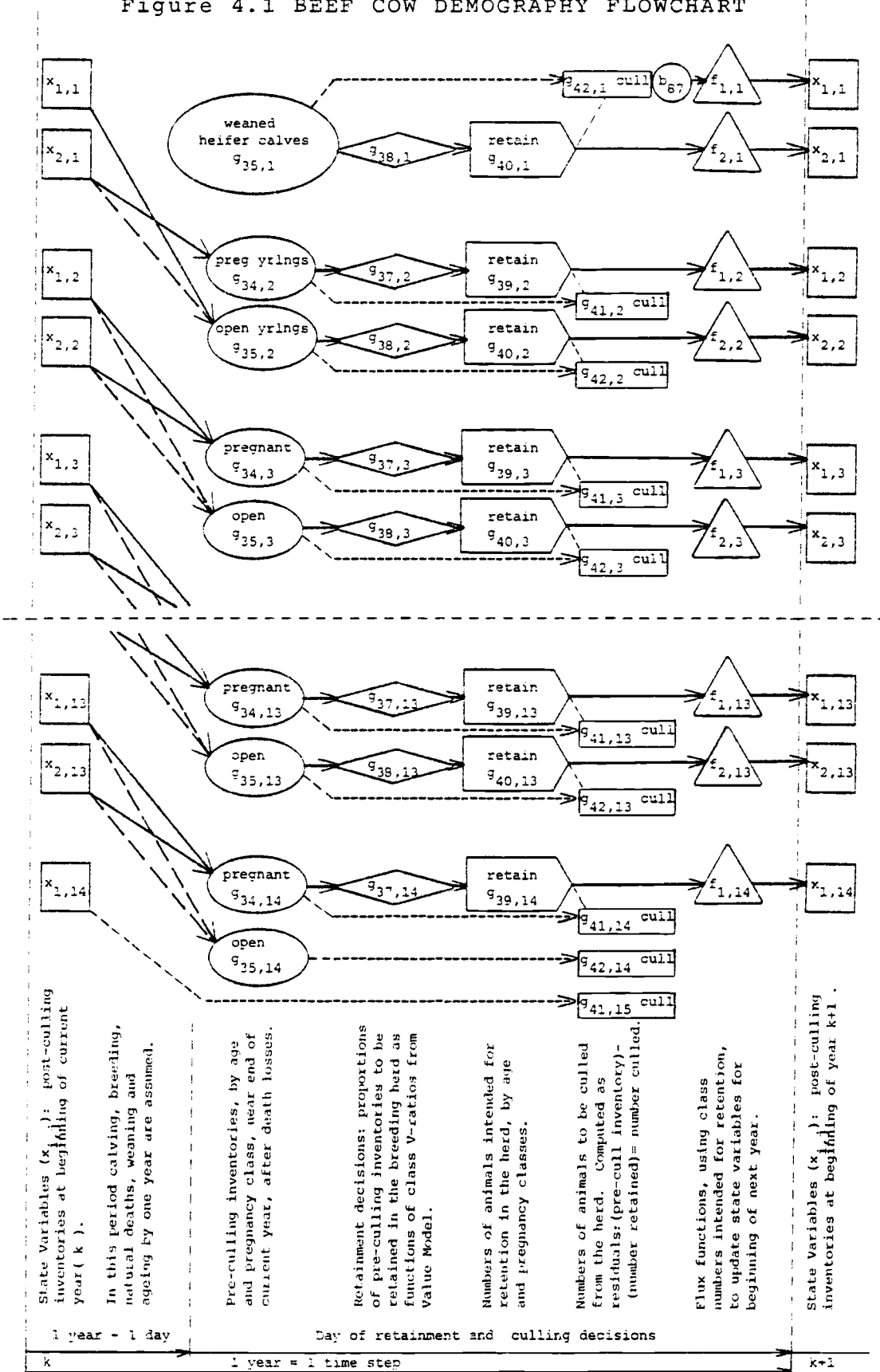

the year-end pre-culling inventories of the (now-one-year-older) new pregnant and non-pregnant classes, respectively. The V-ratios, developed in the value model described above, are used in decision rules ($g_{37,j}$ and $g_{38,j}$) to determine the proportions of each class in the pre-culling inventory to be retained each year of a simulation run.

From the pre-culling inventories and the decisions on what proportions of them to retain, the numbers of animals retained in the post-culling inventories ($g_{39,j}$ and $g_{40,j}$) of pregnant and non-pregnant classes are calculated. The numbers culled from each class are calculated as the residuals ($g_{41,j}$ and $g_{42,j}$) between the pre-culling inventories and the post-culling (retained) inventories.

Other functions are specified to summarize the January 1 inventory numbers of retained cows and heifers, and annual flows of culls and calves born. These numbers are used in the model's output reports and for statistical comparisons with historical inventories and flows. The statistical comparisons are the main subject of Chapter 5. In the remaining pages of the present chapter the details of the demography model are described.

State Variables

Two sets of state variables, $x_{1,j}$ and $x_{2,j}$, are defined to represent the beginning inventory numbers of heifers and cows becoming j years old. With the exception of $x_{1,1}$, all $x_{1,j}$ variables refer to numbers of pregnant animals. Without exception, the $x_{2,j}$ variables refer to numbers of non-pregnant animals. For example $x_{2,5}$ is the number of non-pregnant cows, becoming 5 years old in the beginning inventory of a given year,

while $x_{1,5}$ is the number of pregnant cows, becoming 5 years old. All $x_{i,j}$ variables are in units of 100,000 head.

In the first year of a simulation run, the initial values of these state variables must be specified. That is, some initial age structure must be assumed in terms of numbers of heifers and cows in each age and pregnancy class. The initial age structures used in experimental runs of the model are discussed in Chapter 5. The purpose of the present section is merely to describe the computational structure of the model.

The arbitrary rule of culling all cows becoming 15 years old (pregnant or not) was discussed earlier in this chapter. Another rule has been established which affects only non-pregnant cows becoming 14 years old. The rule is that all of these animals shall be culled, that is, not allowed to enter their 14th year. Thus, for $x_{2,j}$ (the non-pregnant classes), j goes from 1 to 13 year olds, while the pregnant classes go from 2 to 14 year olds.

A special state variable ($x_{1,1}$) has been established for weaned heifers not kept for breeding, but which are potentially available for recruitment as non-pregnant yearlings next year. This was necessary to allow for two phenomena observed in the national herd. The first is the fact that many heifers have been bred to calve for the first time as 3 year olds, particularly in the early half of this century. Over the period examined by this study (1950-1978) it has been more popular to breed heifers to calve as 2 year olds. The second phenomenon is the recruitment of yearling heifers for breeding from the ranks of slaughter-bound steers and heifers. When a year of suddenly bright prospects follows a year in which the future had appeared grim, heifers originally

sold into the slaughter stream as weaned calves may be redeemed as yearlings by newly optimistic breeders.

The national aggregate cow herd is analogous to an individual herd which recruits heifers for breeding from among its own heifer calves and which never purchases cows from the outside. Thus, the demography model portrays an essentially closed herd. For example, the number of cows becoming 3 years old in a given year's post-culling inventory must always be less than the number of heifer calves weaned two years before. Likewise, the number of 5 year olds in the herd next year must always be less than the number of 4 year olds this year. In general, the model requires the numbers of animals in a given age class in a given year to be less than the numbers in the next younger age class the previous year. In-migration to the national breeding herd, as may occur when individual herds purchase cows or heifers, is not allowed in the present model.

Heifer recruitment and cow retention decisions, the ageing process and herd productivity measures are included in the demography model. The first calculations are of the pre-culling inventories of the pregnant and non-pregnant classes. The assumptions that lactating and dry cows of the same ages will have identical rates of conception, unimpaired health and survival were discussed in Chapter 2. These assumptions are given explicit form in the following equations. The pre-culling inventories of the pregnant classes are calculated by the $g_{34,j}$ functions, in 100,000 head units.

For $j = 2$ to $14 =$ age becoming,

$$g_{34,j} = \begin{cases} x_{2,1} g_{3,2} g_{1,1} & , \text{if } j = 2 \\ \left[x_{1,(j-1)} + x_{2,(j-1)} \right] g_{3,j} g_{1,(j-1)} & , \text{if } j > 2 \end{cases}$$

The only animals which may become part of the class of pregnant yearling heifers ($g_{34,2}$) in the pre-culling inventory are those which were weaned heifers kept for breeding (HKB's = $x_{2,1}$) at the beginning of the year, which both survived and conceived, at the rates $g_{3,2}$ and $g_{1,1}$, respectively.

The pregnant animals in any age class becoming 3 or more years of age in the pre-culling inventory are animals which were either pregnant ($x_{1,j}$) or non-pregnant ($x_{2,j}$) in the year's beginning inventory. The total number of animals in the beginning inventory of a given age class is multiplied by the appropriate survival and conception rates ($g_{3,j}$ and $g_{1,(j-1)}$). The proportions of these pregnant animals which are subsequently to be retained in the herd depend on their respective retention functions ($g_{37,j}$). The numbers of these animals retained are then calculated in the $g_{39,j}$ function.

The pre-culling inventories of the non-pregnant classes are determined in a manner similar to those for the pregnant classes. The pool of weaned heifers, from which the youngest recruits to the breeding herd may be selected, are calculated as $g_{35,1}$. This equation calculates the sum of the pregnant cows in each age class of the beginning inventory ($x_{1,j}$) multiplied by their respective calf survival rates ($g_{8,j}$). It is

further assumed that heifers comprise exactly half of the calves born and weaned.

For $j = 1$ to 14

$$g_{35,j} = \begin{cases} (1/2) \left\{ \sum_{i=2}^{14} x_{1,i} g_{8,i} \right\} & , \text{if } j = 1 \\ \left[x_{2,1} g_{3,2} (1 - g_{1,1}) \right] + x_{1,1} & , \text{if } j = 2 \\ \left[x_{1,(j-1)} + x_{2,(j-1)} \right] g_{3,j} (1 - g_{1,(j-1)}) & , \text{if } j > 2 \end{cases}$$

where: $g_{35,j}$ = pre-culling inventory (in 100,000 head units) of non-pregnant animals becoming j years of age.

The class of non-pregnant yearling heifers in the pre-culling inventory ($g_{35,2}$) arises from two sources in the model. The first is the number of weaned heifers kept for breeding in the beginning inventory ($x_{2,1}$) which survive but do not conceive. The second is the special class of heifers ($x_{1,1}$) which were not kept for breeding in the preceding year but remain available for potential recruitment as non-pregnant yearlings.

The numbers of non-pregnant cows becoming 3 years old and over in the pre-culling inventory are calculated in the same manner as for their pregnant age cohorts, except for the use of the complements of conception rates.

The proportions of the pre-culling inventories of non-pregnant heifers and cows which are to be kept for the next breeding season depend on their respective retainment functions ($g_{38,j}$). Calculation of the numbers of non-pregnant animals in each age class are subsequently carried out in the $g_{40,j}$ functions.

Retainment Decisions

The concept of limiting the maximum proportion of animals retained in a given class to those having no serious health impairments was developed in Chapter 2. The proportion of healthy animals retained out of the pre-culling inventory of a given class depends on the class V-ratio. For this purpose three general categories of breeding animals are identified. The first includes pregnant heifers and cows of all ages. The second includes only weaned heifers and non-pregnant yearlings. The third includes all non-pregnant cows becoming 3 years old and over.

The first category, pregnant heifers and cows, is distinguished as that of the successful breeders. The second category, weaned heifers and non-pregnant yearling heifers, is comprised largely of untried animals. That is, most of them will have not yet been exposed for breeding. The third category, non-pregnant mature cows, is distinguished as that of recently unsuccessful breeders. Most of these, however, would have formerly been successful breeders or they would likely have been culled from the herd.

The first, second, and third categories then are characterized as successful, untried and unsuccessful animals, respectively. Based on these characterizations, the three categories of animals in the pre-culling inventory face different strengths of culling pressure, when compared on a V-ratio-by-V-ratio basis. These different strengths are expressed in the three retainment decision functions given below. In general, of course, V-ratios well above 1.0 indicate high incentives for retainment, while V-ratios well below 1.0 suggest incentives for heavy culling. The retainment decisions are modeled here as logistic functions

of V-ratios. These functions have been specified to permit convenient experimentation with a variety of shapes and positions.

For $j = 2$ to $14 =$ age becoming, for pregnant animals,

$$g_{37,j} = b_{88} + \left[\frac{g_{2,j} - b_{88}}{1.0 + e^{b_{83}(g_{30,j} - b_{84})}} \right]$$

Where: $g_{37,j}$ = the proportion of the pre-culling inventory of pregnant animals becoming j years old which are to be retained in the herd (see Figure 4.2),

$g_{2,7}$ = the maximum proportion to be retained = the rate of unimpaired health (asymptotic upper limit) for pregnant animals,

b_{88} = the minimum proportion to be retained (asymptotic lower limit) for pregnant animals,

$g_{30,j} = V_j^P$ -ratios for pregnant animals becoming j years old: The decision variables computed by the value model,

b_{84} = inflection point, establishing the horizontal position of the decision curve for pregnant animals,

b_{83} = a parameter establishing the gentleness or abruptness of the decision curve for pregnant animals.

When the incentives for heavy culling are strong, for a particular age and pregnancy class, only the most exceptional animals in the class will be retained. The asymptotic lower limit to the decision curve expresses the intuition that no matter how grim the future may appear, at least some animals are retained in every age group.

The retainment decisions for the two non-pregnant categories are given in the $g_{38,j}$ functions. The asymptotic upper retainment limits for these animals are constant fractions (b_{94} and b_{91}) of the respective

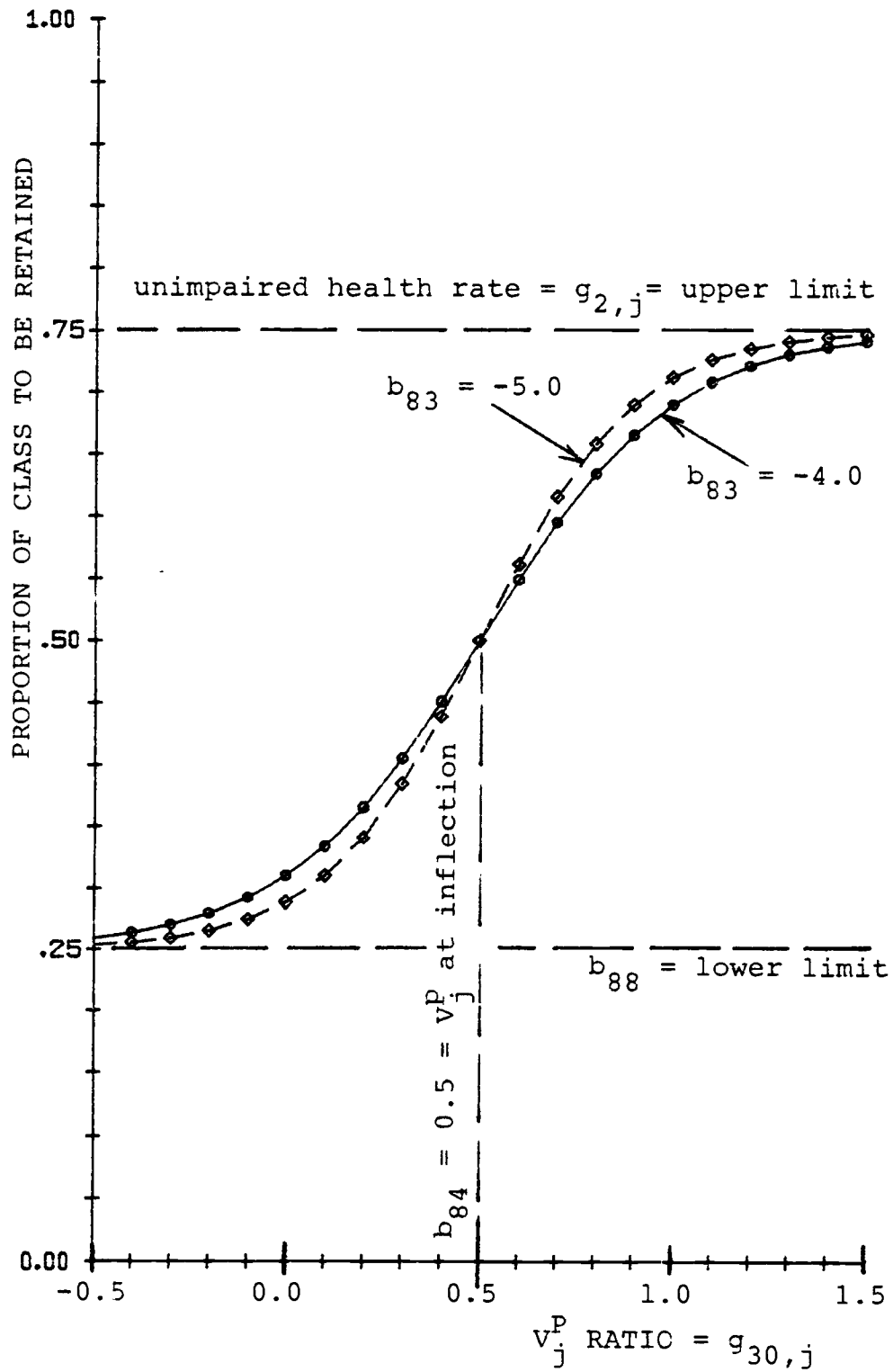
FIGURE 4.2 RETAINMENT DECISION FUNCTION: $g_{37,j}$ 

rates of unimpaired health ($g_{2,j}$). Otherwise, the functional forms are identical to that for the pregnant animals. These distinguishing factors express the author's intuition that there never has been a time when all healthy non-pregnant animals in the nation were retained in the herd.

The second category, weaned heifers and non-pregnant yearling heifers, and the third, all non-pregnant cows becoming 3 years old and over, are considered in separate conditional parts of $g_{38,j}$.

For $j = 1$ to $13 =$ age becoming for non-pregnant heifers and cows;

$$g_{38,j} = \left\{ \begin{array}{l} b_{89} + \frac{(b_{94}g_{2,j}) - b_{89}}{1.0 + e^{b_{92}(g_{32,j} - b_{93})}} \quad , \text{ if } j \leq 2, \\ \text{the second} \\ \text{category} \\ \\ b_{90} + \frac{(b_{91}g_{2,j}) - b_{90}}{1.0 + e^{b_{85}(g_{32,j} - b_{86})}} \quad , \text{ if } j > 2, \\ \text{the third} \\ \text{category} \end{array} \right.$$

where: $g_{38,j}$ = proportion of the pre-culling inventory of non-pregnant animals becoming j years old which are to be retained in the herd,

$b_{94} \cdot g_{2,j}$ and $b_{91} \cdot g_{2,j}$ = maximum proportions to be retained (asymptotic upper limits) for non-pregnant classes,

b_{89} and b_{90} = minimum proportions to be retained (asymptotic lower limits) for non-pregnant classes,

$g_{32,j} = V_j^N$ -ratios for non-pregnant animals becoming j years old: the decision variables computed by the value model,

b_{93} and b_{86} = inflection points establishing the horizontal positions of the decision curves for non-pregnant classes,

b_{92} and b_{85} = parameters establishing the gentleness or abruptness of the decision curves.

Animals with poor, normal and exceptionally good characteristics are distributed within each age and pregnancy class. The class means are represented by the class V-ratios such that the poorest animals of a high V-ratio class may not look as good as the best individuals in a lower V-ratio class. Therefore, the structure of the retainment decision functions allow some cows in low V-ratio classes to be retained while some cows in the higher V-ratio classes are culled.

Numbers Retained and Culled

The numbers of animals to be retained in the post culling inventories of each age and pregnancy class are calculated as the simple products of their respective pre-culling inventories and proportional retainment rates. The post culling inventories of all pregnant classes are calculated first by $g_{39,j}$.

For $j = 2$ to 14 = age becoming for pregnant animals,

$$g_{39,j} = g_{34,j} g_{37,j}$$

Where: $g_{39,j}$ = the number of pregnant animals becoming j years old in the post culling inventory (to be retained in the herd, in 100,000 head units),

$g_{34,j}$ = pre-culling inventory of pregnant animals becoming j years old,

$g_{37,j}$ = the proportion of pregnant animals becoming j years old to be retained in the herd.

Likewise, the post-culling inventories of the non-pregnant classes are calculated in $g_{40,j}$.

For $j = 1$ to 13 = age becoming, for non-pregnant heifers and cows;

$$g_{40,j} = g_{35,j} g_{38,j}$$

where: $g_{40,j}$ = the number of non-pregnant animals becoming j years old in the post culling inventory (to be retained in the herd, in 100,000 head units),

$g_{35,j}$ = pre-culling inventory of non-pregnant animals becoming j years old,

$g_{38,j}$ = the proportion of non-pregnant animals, becoming j years old, to be retained in the herd.

Calculation of the numbers of each class culled is only a matter of finding the difference between the pre-culling inventories and the numbers to be retained for each age and pregnancy class. Thus, all the survivors which are not to be retained are culled. First, numbers culled from the pregnant classes are determined by $g_{41,j}$.

For $j = 2$ to 15 = age becoming for pregnant animals;

$$g_{41,j} = \begin{cases} g_{34,j} - g_{39,j} & , \text{ if } j < 15 \\ x_{1,14} g_{3,15} & , \text{ if } j = 15 \end{cases}$$

where: $g_{41,j}$ = the number of pregnant animals culled prior to becoming j years old (in 100,000 head units),

$g_{34,j}$ = pre-culling inventory of pregnant animals becoming j years old,

$g_{39,j}$ = number of pregnant animals becoming j years old which are to be retained in the herd,

$x_{1,14}$ = beginning inventory of pregnant cows becoming 14 years old,

$g_{3,15}$ = survival rate of cows in the year prior to becoming 15 years old.

Note that all cows are assumed to be culled prior to becoming 15 years old. Similarly, all non-pregnant cows becoming 14 years old are assumed to be culled; there being little justification for maintaining an elderly cow for a full year (with no chance of producing a weaned calf), only to be culled for old age. Their numbers and those of the younger culls are calculated by $g_{42,j}$ in units of 100,000 head.

For $j = 1$ to 14 = age becoming for non-pregnant animals;

$$g_{42,j} = \begin{cases} g_{35,j} - g_{40,j} & , \text{ if } j < 14 \\ g_{35,14} & , \text{ if } j = 14 \end{cases}$$

While the entire pre-culling inventory of non-pregnant cows becoming 14 years old ($g_{35,14}$) are assumed to be culled, culling in the younger classes of non-pregnant animals is simply the difference between their respective pre-culling inventories ($g_{35,j}$) and numbers to be retained ($g_{40,j}$). As with the pregnant classes, all survivors not to be retained are culled. An output summary report is made for the cows culled each year. Beyond this, however, these cows are assumed to be slaughtered and essentially vanish from the demography model.

The total retained breeding herd inventory (pregnant yearlings and cows, and non-pregnant cows) is summed up by the function $g_{43,1}$. The

demography model carries all inventory classes in units of 100,000 head, while here the total brood cow inventory is translated into units of a million head. This "total cow numbers" figure is reported as one of the model's annual output functions, $Y_{1,2}$.

$$g_{43,1} = \left\{ \left(b_{98} g_{39,2} \right) + \left(\sum_{i=3}^{14} g_{39,i} \right) + \left(\sum_{i=3}^{13} g_{40,i} \right) \right\} \quad (0.1)$$

where: $g_{43,1}$ = total brood cow inventory (including first calf heifers), comparable to the U.S.D.A. January 1 inventory of beef cows that have calved (million head units),

$b_{98} g_{39,2}$ = The number of first calf heifers included in the inventory (b_{98} = adjustment factor),

$g_{39,i}$ = pregnant cows, becoming 3 years old and over, to be retained in the herd,

$g_{40,i}$ = non-pregnant cows, becoming 3 years old and over, to be retained in the herd.

The next summary calculation reflects some uncertainty regarding the reporting basis of the U.S.D.A. statistics on heifers kept for breeding. The parameters of $g_{43,2}$ (b_{96} , b_{95} and b_{97}) may be set at any values between 0 and 1.0 as weighting factors for experimental inclusion of various proportions of weaned heifers and pregnant and non-pregnant yearling heifers, respectively, in the sum of heifers recruited.

$$g_{43,2} = \left\{ \left(b_{95} g_{39,2} \right) + \left(b_{96} g_{40,1} \right) + \left(b_{97} g_{40,2} \right) \right\} \quad (0.1)$$

where: $g_{43,2}$ = the number of "heifers for replacements" (in million head units) for comparison with objective historical series from the U.S.D.A., reported as one of the model's output functions, $Y_{1,3}$,

$(b_{95} \cdot g_{39,2})$ = the number of pregnant yearling heifers included in the simulated sum,

$(b_{96} \cdot g_{40,1})$ = the number of weaned heifers kept for breeding that are included in the simulated sum,

$(b_{97} \cdot g_{40,2})$ = the number of non-pregnant yearlings included in simulated sum.

An earlier version of this simulation model only considered yearling heifers in this category and excluded the pregnant yearlings from the beef cow inventory. Comparison of the results of the early-version runs with the objective historical series indicated the need for including the pregnant yearling heifers in the beef cow inventory, and the weaned heifers kept for breeding in the inventory of heifers for "replacement".

As mentioned earlier in the text, the common usage of the term "replacement" is a misnomer. These animals are, more correctly, referred to here as heifers recruited to the breeding herd, or simply "recruits". This is so because heifers are commonly recruited for breeding in numbers too large or too small to sustain a constant rate of growth. In other words, heifers have apparently been recruited to the breeding herd at rates directly related to cow retainment rates. Thus, when cow culling has been intense, heifer recruitment has also declined.

The sum of simulated cull cow numbers is computed in the function $g_{43,3}$, again in million head units, for comparison with the objective historical series on annual beef cow slaughter numbers from the U.S.D.A.

$$g_{43,3} = \left\{ \left(\begin{array}{c} 15 \\ \Sigma \\ i=3 \end{array} g_{41,i} \right) + \left(\begin{array}{c} 14 \\ \Sigma \\ i=3 \end{array} g_{42,i} \right) \right\} \quad (0.1)$$

Where: $g_{43,3}$ = simulated number of culled pregnant and non-pregnant beef cows, becoming 3 years old and over (million head units).

$g_{41,i}$ = culled pregnant cows

$g_{42,i}$ = culled non-pregnant cows

This "cull cows" total is reported in one of the model's annual output functions, $Y_{1,4}$.

The next summary function ($g_{43,4}$) calculates the number of calves weaned in the current year of the simulation, in 100,000 head units. The numbers of pregnant heifers and cows of each age group in the beginning inventory ($x_{1,j}$) are multiplied by their respective calf survival rates ($g_{8,j}$), then summed across ages. The calf survival rates, developed in Chapter 2, account for pre-natal mortality (i.e., spontaneous abortions) from the time of retainment decisions at culling time to the time of calving, as well as deaths at birth and deaths from birth to weaning. Recall that the lowest calf survival rates are assumed to occur with the first calving heifers.

$$g_{43,4} = \sum_{i=2}^{14} (x_{1,i} g_{8,i})$$

The number of calves weaned in a given year, relative to different measures of herd size, are key indications of herd productivity. For example, the simulation model output function $Y_{1,6}$ reports the number of calves weaned in the current year per cow and heifer exposed for breeding the previous year. The output function $Y_{1,7}$ reports calves weaned per cow and heifer becoming 2 years old and over in the beginning inventory of the current year. $Y_{1,8}$ reports calves weaned per pregnant cow and

heifer in the beginning inventory. Finally, $Y_{1,14}$ reports calves weaned per calf born in the current year. The reader may refer to the FLEXFORM model documentation in Appendix A for the specific formulas used in calculating these outputs.

The total number of cows and heifers on inventory at the beginning of the current year as pregnant and non-pregnant animals becoming 2 years old or over is calculated by $g_{43,5}$, in 100,000 head units.

$$g_{43,5} = \left(\begin{array}{c} 14 \\ \Sigma \\ i=2 \end{array} x_{1,i} \right) + \left(\begin{array}{c} 13 \\ \Sigma \\ i=2 \end{array} x_{2,i} \right)$$

This measure of herd size is used in several herd performance statistics including $Y_{1,7}$ mentioned above. Non-pregnant yearling heifers ($x_{2,2}$) are not included in the measure of breeding herd size specified in $g_{43,1}$, while they are included in $g_{43,5}$ which is used in measures of herd efficiency.

The last summary calculation in the demography model is an estimate of the total number of calves born to beef cows in the current year, in million head units. This number should be comparable to a derived objective historical series on beef calves born in the U.S.

$$g_{43,6} = \left\{ \begin{array}{c} 14 \\ \Sigma \\ i=2 \end{array} (x_{1,i} g_{3,(i+1)}) \right\} \quad (0.1)$$

It is assumed that live calf births may be estimated as the sum of the products of pregnant animal beginning inventories ($x_{1,j}$) and their respective cow survival rates ($g_{3,(j+1)}$). In other words, all cow deaths are assumed to take place around calving time and, in pregnant cows, cause the loss of their calves as well. These assumptions are made for

the sake of computational convenience and in the author's opinion ought to cause little bias in the result. In reality, cows may die at any time of the year, and new-born calves do sometimes survive the death of their dams.

FLUX Functions

The updating of state variables through simulated time is accomplished by FLUX (or delta) functions in the FLEX modeling system used here. For each state variable $x_{i,j}$ (cattle inventory class) in the model there is a corresponding FLUX function, $f_{i,j}$. The state variable updating process, where k indicates the current time step, operates very simply:

$$x_{i,j(k+1)} = x_{i,j(k)} + f_{i,j(k)} = x_{i,j(k)} + \Delta X_{i,j(k)}$$

The state variables in the present model are (with the exception of $x_{1,1}$) the post-culling beginning inventories, by age and pregnancy classes, of animals retained in the breeding herd. The numbers of pregnant animals to be retained at the end of the current year are calculated by $g_{39,j}$, while the numbers of non-pregnant animals to be retained are calculated by $g_{40,j}$. A FLUX function is defined to determine the quantity which, when added to the old value of its corresponding state variable, gives the new (updated) value of the state variable. Thus, FLUX functions may have negative or positive real values as the number of animals in a given age class shrinks or grows from one year to the next.

For $j = 1$ to $14 =$ age becoming,

$$f_{1,j} = \begin{cases} (g_{42,1} b_{87}) - x_{1,1} & , \text{ if } j = 1 \\ g_{39,j} - x_{1,j} & , \text{ if } j > 1. \end{cases}$$

The special class ($x_{1,1}$) of weaned heifers not kept for breeding, but potentially considered available for retainment in the future as non-pregnant yearlings, is assigned the FLUX function $f_{1,1}$ shown above. The total number of weaned heifers not to be retained ($g_{42,1}$) times a constant fraction (b_{87}) gives the new value of $x_{1,1}$. Subtracting the old value of $x_{1,1}$ yields the change ($f_{1,1} = \Delta x_{1,1}$) in this state variable from the beginning of the current year to the beginning of the coming year. For $j > 1$, $f_{1,j}$ very simply calculates the change in the size of the $x_{1,j}$ pregnant inventory class from the beginning of the current year to the beginning of the coming year.

FLUX functions for the non-pregnant classes are equally straightforward: for $j = 1$ to 13 = age becoming,

$$f_{2,j} = g_{40,j} - x_{2,j}$$

These functions, of course, calculate the changes in the numbers of non-pregnant animals comprising the $x_{2,j}$ inventory classes from the beginning of the current year to the beginning of the coming year.

The reader is referred again to Figure 4.1 which shows the flow of the cattle inventory change process modeled here. The ageing and attrition of a group of animals, born in a given year, may be clearly traced from the time they were weaned heifers until, 14 years later when a small fraction of them are culled for old age.

This completes the detailed description of the body of the beef cow value and the demography model. The FLEXFORM summary version of the model is given in Appendix A. Included also in the FLEXFORM are additional parameters and statistical functions which compare the simulated and his-

torical numbers of the four key classes of animals: cows ($g_{43,1}$); heifers ($g_{43,2}$); culls ($g_{43,3}$); and calves born ($g_{43,6}$). The objective historical series and the statistical processes for comparing them with the simulated series are defined in Chapter 5.

CHAPTER 5

VALIDATION, RESULTS AND CONCLUSIONS

Behavior of the beef cow value and demography model is evaluated by statistical and graphical methods in this Chapter. Conclusions drawn from the study, their limitations and indications for future research are also discussed. The statistical measures of comparing the simulated and historical series of cows, heifers, culls and calf numbers are presented first.

Historical Data

The objective historical series, against which the simulated numbers are compared, were taken from a U.S.D.A. data source (U.S.D.A., ESS, T-DAM, 1979).

The U.S.D.A. beef cow series were derived, before 1965, as estimates of cows and heifers that have calved, from the historical series on cows and heifers aged 2 years and older. The latter series was discontinued by the U.S.D.A. in 1971. January 1 inventories from 1950 to 1979 are used. The 1950 inventory estimate of 15.95 million cows that have calved is used as the beginning inventory for all simulation runs. The initial age and pregnancy distributions of these animals, for the main example run of this Chapter, are given in the list of state variables in the FLEXFORM (Appendix A). The

January 1 beef cow inventories from 1951 through 1979 are given as parameter values in the FLEXFORM also (b_{101} through b_{129}).

U.S.D.A. estimates of heifer numbers for breeding, on the January 1 inventories from 1951 through 1979, are also given as the parameter values of b_{131} through b_{159} , respectively.

Annual estimates of beef cow slaughter numbers, from 1950 through 1978, are shown as the FLEXFORM parameter values b_{160} through b_{188} , respectively.

The data on numbers of beef calves born were derived from U.S.D.A. estimates of total calves born and dairy cow numbers. It was assumed that the number of dairy cows, multiplied by 0.92, would yield the number of dairy calves born in the U.S. The numbers of beef calves born were thus computed as the residual of the total minus dairy calves. These estimates are given as the values of parameters b_{190} through b_{218} for the years 1950 through 1978, respectively.

The inclusion of the objective series as model "parameters" was only for the sake of convenience in making all statistical comparisons automatically as the model was run each time. The presence of these data have no effect on the operation of the value and demography model except as they allow instant viewing of the differences between simulated and historical series at the completion of a run.

Statistical Comparison of Simulated and Historical Series

A number of quantities are simulated for which no historical data exist, such as the changing age structure of the herd

through time. These provide the most interesting outcomes and are in fact the main reason for using a simulation approach. These are discussed later in this chapter.

The credibility of a simulation model is affected by its theoretical tenability and by objective measures of its ability to track real world behavior. The theoretical tenability of the present model may be judged by the reader based on its presentation in the previous chapters. The measures used to compare the model's outputs with objective historical series are briefly described here. Their computational details are included in the FLEXFORM, Appendix A.

The author made a strategic decision to append the statistical comparison algorithms directly to the simulation model, rather than carry them out in a separate process. This was intended to reduce turn-around time, data manipulation errors and costs. This was weighed against the extra modeling and programming time for including the statistical comparisons in the simulation program. In the hindsight afforded the author, after making over a hundred runs with different versions of the present model, the choice of including the statistical routines has been well vindicated.

It is a simple matter to change parameter values for a new run of the present model. The entire process of calling up the files and the FLEX program, then processing the model and printing out the statistical summaries could be accomplished at a remote computer terminal in under 5 minutes. Only if a simulation run had some feature of particular interest would a full-line printer output be called for or would data files for plotting be saved.

A set of comparison statistics is computed for each of the four simulated series and their respective historical series during a run. The four series compared are, again: January 1 inventories of cows and recruited heifers and the annual numbers of cows culled and calves born. In addition to a side by side listing of the simulated and historical series in each of these classes the annual ratios of simulated to historical numbers are calculated. The model then computes 6 summary statistics comparing the series over the entire 29 year run.

The first is the mean proportional absolute deviation (MPAD) of the simulated series from the historical series. The proportional absolute deviations of the simulated numbers from the respective historical observations are summed, each year of the simulation run, by the use of memory variables:

$$g_{44,i} = m_{3,i} + |S_i - H_i|/H_i$$

where:

S_i = simulated, H_i = historical, $m_{3,i}$ = previous years' sum

$i = 1$ for cow inventories

$i = 2$ for heifer inventories

$i = 3$ for cull cow numbers

$i = 4$ for numbers of calves born

In the last year of a simulation run the mean proportional absolute deviations are computed as output functions:

$$Y_{(7+i),2} = \frac{g_{44,i}}{b_{99}} = \left(\frac{\sum \left| \frac{S_i - H_i}{H_i} \right|}{n} \right)$$

where i is as defined above, and $b_{99} = n = 29$ years. These "average error" statistics are most useful in that their interpretations are straightforward. Because they are in proportional terms, a ten percent deviation early in the run counts as heavily as a ten percent deviation near the end of the run where, for example, cow numbers were historically three times greater.

The remaining comparative statistics are based on transformations of the series into terms of annual proportional changes, P (predicted changes) and A (actual changes). Where S_k and S_{k-1} are the simulated numbers in the current and previous years and (k and $k-1$) respectively, $P = (S_k - S_{k-1})/S_{k-1}$. Likewise, where H_k and H_{k-1} represent the historical numbers for the current and previous years (k and $k-1$) respectively, $A = (H_k - H_{k-1})/H_{k-1}$.

Based on the transformed series P and A , standard deviations, simple correlation coefficient and, in turn, Theil's coefficient of inequality (U), and its decomposition statistics (U^m , U^s , and U^c), are calculated.

Special formulae are used for computing the standard deviations and correlation coefficients of the transformed series. Shown in Appendix B, these formulae are particularly convenient because they may be computed from sums accumulated time-step-by-time-step.

Transformations and summations are carried out at each time step (year) in the course of a simulation run. The sums, sums of squares, sums of products and sums of squared differences are accumulated, as simulated time progresses, to be used at the end of the run in the calculation of summary comparison statistics of the simulated and historical series. The details of this summation process (specific functions) are given in the FLEXFORM (Appendix A).

In general the calculations proceed, each year, in the following manner:

$$g_{4i,1} = P = (S_k - S_{k-1})/S_{k-1}$$

$$g_{4i,2} = A = (H_k - H_{k-1})/H_{k-1}$$

$$g_{4i,3} = m_{i,3} + g_{4i,1} = \Sigma P$$

$$g_{4i,4} = m_{i,4} + (g_{4i,1})^2 = \Sigma P^2$$

$$g_{4i,5} = m_{i,5} + g_{4i,2} = \Sigma A$$

$$g_{4i,6} = m_{i,6} + (g_{4i,2})^2 = \Sigma A^2$$

$$g_{4i,7} = m_{i,7} + (g_{4i,1} g_{4i,2}) = \Sigma PA$$

$$g_{4i,8} = m_{i,8} + (g_{4i,1} - g_{4i,2})^2 = \Sigma (P - A)^2$$

The sequence of transformations and summations shown above is repeated for each of these classes.

where:

$i = 5$ for cow inventory comparisons (in $g_{45,j}$ and $m_{5,j}$)

$i = 6$ for heifer recruitment comparisons (in g_{46} and $m_{6,j}$)

$i = 7$ for cull cow comparisons (in $g_{47,j}$ and $m_{7,j}$)

$i = 8$ for calves-born comparisons (in $g_{48,j}$ and $m_{8,j}$).

The $m_{i,j}$ terms are memory variables which recall the previous year's value of the equations in which they occur (i.e., $m_{5,8}$ recalls the value calculated by $g_{45,8}$ in the previous year).

Calculations of the standard deviations of the year-to-year proportional changes in the simulated (S_P) and historical (S_A) series are carried out only at the end of a simulation run from the sums accumulated during the run. All the terms for these calculations are defined above.

$$g_{4i,9} = (1/28) \sqrt{28 g_{4i,4} - (g_{4i,3})^2} = S_P = (1/n) \sqrt{n \Sigma P^2 - (\Sigma P)^2}$$

and

$$g_{4i,10} = (1/28) \sqrt{28 g_{4i,6} - (g_{4i,5})^2} = S_A = (1/n) \sqrt{n \Sigma A^2 - (\Sigma A)^2}.$$

The derivation of the standard deviation formula used here is shown in Appendix B. The reader is referred to the FLEXFORM for the details of the category-by-category function descriptions.

The standard deviations computed for comparable simulated and historical period-by-period changes are used in calculating the correlation coefficients,

$$g_{4i,j} = \frac{(28 g_{4i,7}) - (g_{4i,3} g_{4i,5})}{(28)^2 g_{4i,9} g_{4i,10}} = r = \frac{n \Sigma PA - (\Sigma P)(\Sigma A)}{n^2 (S_P S_A)}$$

where all terms are as defined above. The derivation of the functional form is shown in Appendix B (see Johnston, 1972, p. 34, for a similar form).

Of course a positive correlation coefficient near 1.0 is highly desirable while near-zero or negative values would be disappointing.

Theil's (1966) inequality coefficient, U, was designed for ex-post evaluation of the quality of single-period forecasts; for example, a sequence of actual (A) and predicted (P) changes in some variable of interest. Theil's method has been adopted, for use in the present simulation validation context, by transforming the simulated (S_k) and historical (H_k) series into a series of single-period proportional changes, A and P, as shown above. Koutsoyiannis (1977) and Paulsen, et al. (1973) offer discussions of Theil's U statistic; while applications similar to the present use are shown by: Crom (1970), Rosen and Mathur (1973), Paulsen, et al. (1973), Mathur and Rosen (1974), Folwell and Shapouri (1977) and Lin (1980).

The formula for Theil's inequality coefficient is given as:

$$U = \sqrt{\frac{(1/n) \sum (P - A)^2}{(1/n) \sum A^2}} = \sqrt{g_{4i,8}/g_{4i,6}}$$

For perfect forecasts, where the predicted changes were all equal to the actual changes, the numerator would vanish, and $U = 0$. In the case of naive forecasts of zero change (as when tomorrow's weather is always forecasted to be like today's), $P = 0$, leaving the numerator identical to the denominator, and $U = 1.0$.

Since it is possible to have forecasting performance worse than by naive (no change) forecasts, Theil's U statistic provides an objective measure of how much worse. Obviously, if one's forecasting method yields U values greater than 1.0, one may objectively state that the naive forecast would be preferred.

Theil (1966, pp. 19-32) also defined the proportions of inequality between the A and P series due to mean bias (U^m), unequal variance (U^S) and imperfect covariance (U^C). These are based on the fact (shown in Appendix B) that the numerator of Theil's inequality coefficient may be decomposed into the following expression:

$$(1/n) \sum (P - A)^2 = (\bar{P} - \bar{A})^2 + (S_P - S_A)^2 + 2(1 - r)(S_P S_A),$$

where $\bar{P} = \sum P/n$, $\bar{A} = \sum A/n$ and the other terms are as defined above. Theil shows that the three terms in this decomposition may be used to indicate the source of inequality as:

$$U^m = \frac{(\bar{P} - \bar{A})^2}{(1/n) \sum (P - A)^2} = \text{proportion of inequality due to mean bias,}$$

$$U^S = \frac{(S_A - S_P)^2}{(1/n) \sum (P - A)^2} = \text{proportion of inequality due to unequal variance, and}$$

$$U^C = \frac{2(1 - r)(S_P S_A)}{(1/n) \sum (P - A)^2} = \text{proportion of inequality due to imperfect covariation,}$$

such that: $U^m + U^S + U^C = 1.0$.

Inequality decomposition statistics, as defined above, are also built into the model for comparing each of the objective series with their respective simulated series.

A Display Simulation Run

The results of one of the better runs of the simulation model are presented here. The initial conditions for this run, and all of its parameter values, are given in the FLEXFORM. Table 5.1 shows the statistics comparing the simulation run numbers of cows, heifers, culls and calves born with the objective historical series. Figure 5.1 gives a visual impression of the tracking behavior of the model over the 29 year run.

Visual inspection reveals that tracking is closest for the cow inventories and numbers of calves born. The mean proportional absolute deviation (MPAD) for cow inventories were the best (lowest) at .029 (or 2.9 percent). The cow inventory tracking also displayed the highest correlation coefficient of single period changes (.889) and the best (lowest) coefficient of inequality ($U = .405$).

Most of the inequality between the historical and simulated cow inventories was due to the imperfect covariance ($U^C = .798$), and nearly all the rest was due to unequal variance in the two series ($U^S = .200$). A small proportion of the inequality was due to mean bias ($U^m = .002$).

In the statistics comparing simulated and historical numbers of calves born, there was an average deviation of 3.6 percent (see: MPAD for calves in Table 5.1). The correlation coefficient

TABLE 5.1 COMPARISON STATISTICS FOR SIMULATED AND HISTORICAL NUMBERS

Comparison Class	Output Functions	j = 2	j = 3	j = 4	j = 5	j = 6	j = 7
		MPAD	r	U	U^m	U^s	U^c
COWS	$Y_{8,j} =$.029	.889	.405	.002	.200	.798
HEIFERS	$Y_{9,j} =$.172	.426	.962	.000	.051	.949
CULLS	$Y_{10,j} =$.261	.545	.842	.015	.572	.412
CALVES BORN	$Y_{11,j} =$.036	.731	.587	.001	.131	.868

FIGURE 5.1 SIMULATED AND HISTORICAL NUMBERS: DISPLAY RUN

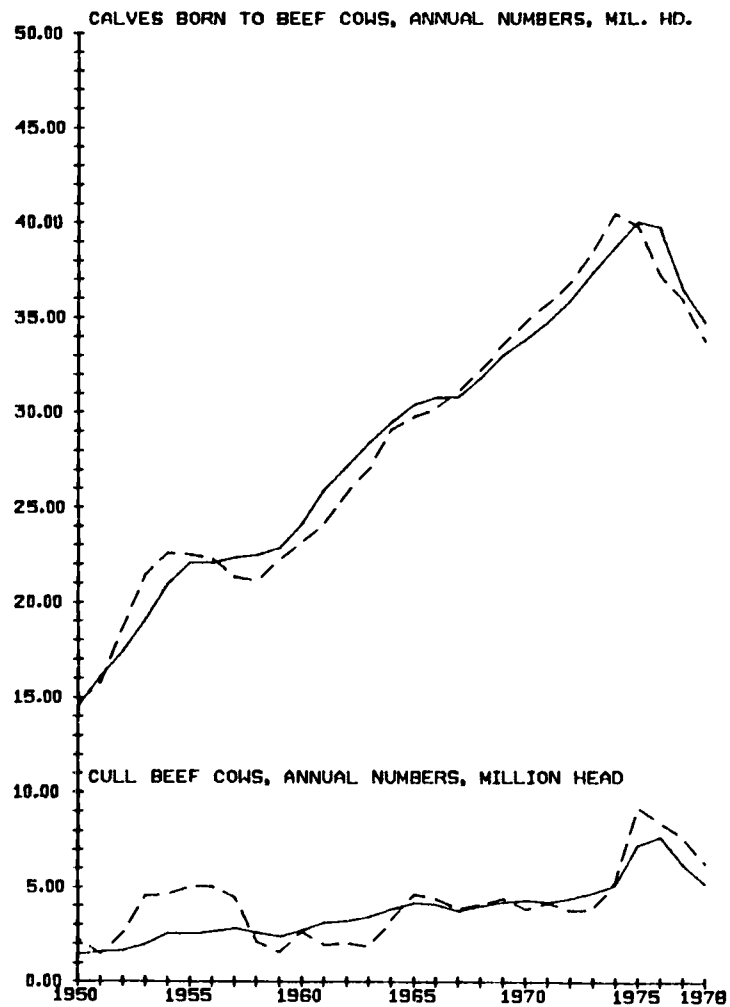
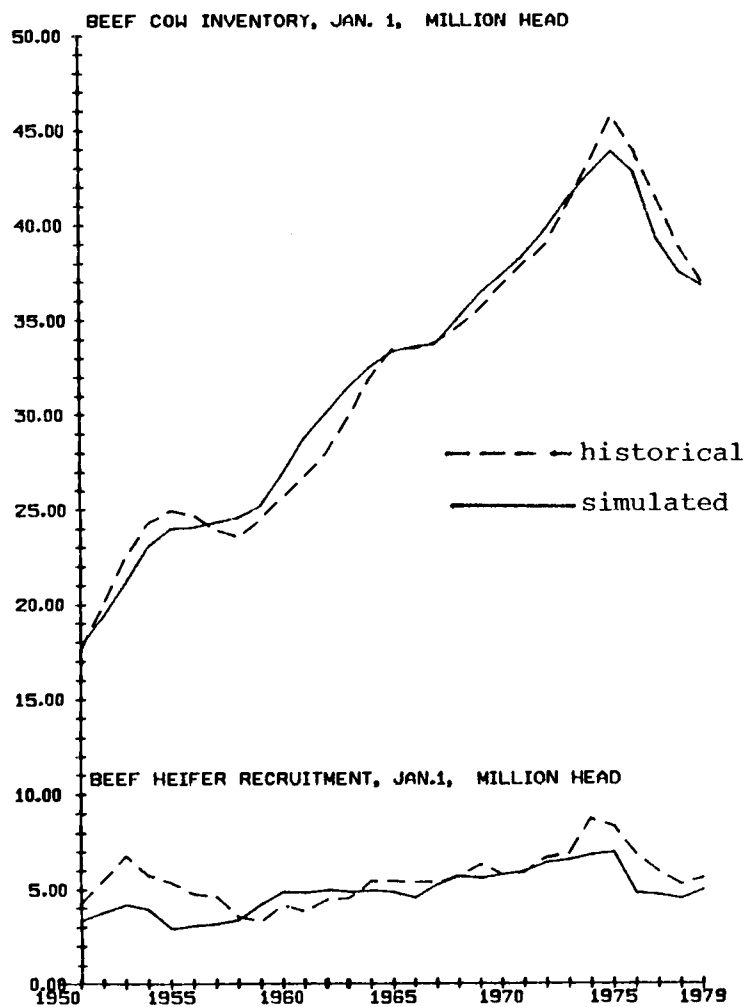

was only second best at .731, to that for cow inventories, likewise in its U statistic.

The tracking performance in heifer and cull numbers were the worst in all respects. The proportion of inequality due to unequal variance was especially marked for culls ($U^S = .572$). This fact is obvious in Figure 5.1 as well. The simulated numbers of culls follow a nearly straight path until the mid-seventies, with an average error of 26.1 percent.

Overall, the simulation performed considerably better than naive forecasting. That is the U statistics were all below 1.0. However, the tracking performance for heifers and culls leaves something to be desired, as their U statistics are uncomfortably close to 1.0.

In this model, the numbers of calves born affect the numbers of heifers retained; recall that variable proportions of the heifers weaned are retained. Numbers of heifers retained affect the cow herd size, as do the numbers culled. Of course herd size and age distribution influence the numbers of calves born. The natural interrelationships between these classes of animals prevents changing the model to improve the tracking of one class without affecting all the others.

Model behavior is most sensitive to changes in the inflection point parameters in the retainment decision functions, $g_{37,j}$ and $g_{38,j}$. Shifting one of these parameters to the left, in the V-ratio dimension, allows greater proportions of animals in the respective class to be retained. The effect is a gradual increase in herd size through many interactions. No mathematical algorithm for approaching

an optimal parameter set was used. Rather, an iterative trial-and-error method of fine tuning, inspection of the comparison statistics, and re-running of parameters was used.

A large number of parameter sets yielded tracking behavior with average errors within 10 percentage points of the values shown here. These were obtained after the present structural form of the model was reached. Therefore, there is no assurance that the parameter set indicated in the FLEXFORM is optimal in a statistical least-squares sense. Had time allowed, in the sense of the author's opportunity costs, further structural refinements and fine tuning may have produced better tracking behavior. The present state of the model is sufficiently revealing for the purpose at hand.

Relative Cow Value Shifts

Figure 5.2 shows the sharply contrasted cow value situations simulated for 1952 and 1976. Cattle prices were high relative to costs in 1952, as reflected in the very "optimistic" relationships of apparent breeding values to slaughter values (PVB_j^P and PVB_j^N relative to PSV_j). Non-pregnant animals 6 years old and younger, appear to be worth as much, or more, if retained in the breeding herd than if sold for immediate slaughter. All pregnant cows have apparent breeding values far above their slaughter values.

The case of 1976 is grim indeed. Only pregnant cows in the prime of productive life (3 to 10 years of age) appear to be worth saving from the slaughter house. Non-pregnant animals have apparent

FIGURE 5.2 OPTIMISTIC AND PESSIMISTIC RELATIVE COW VALUES

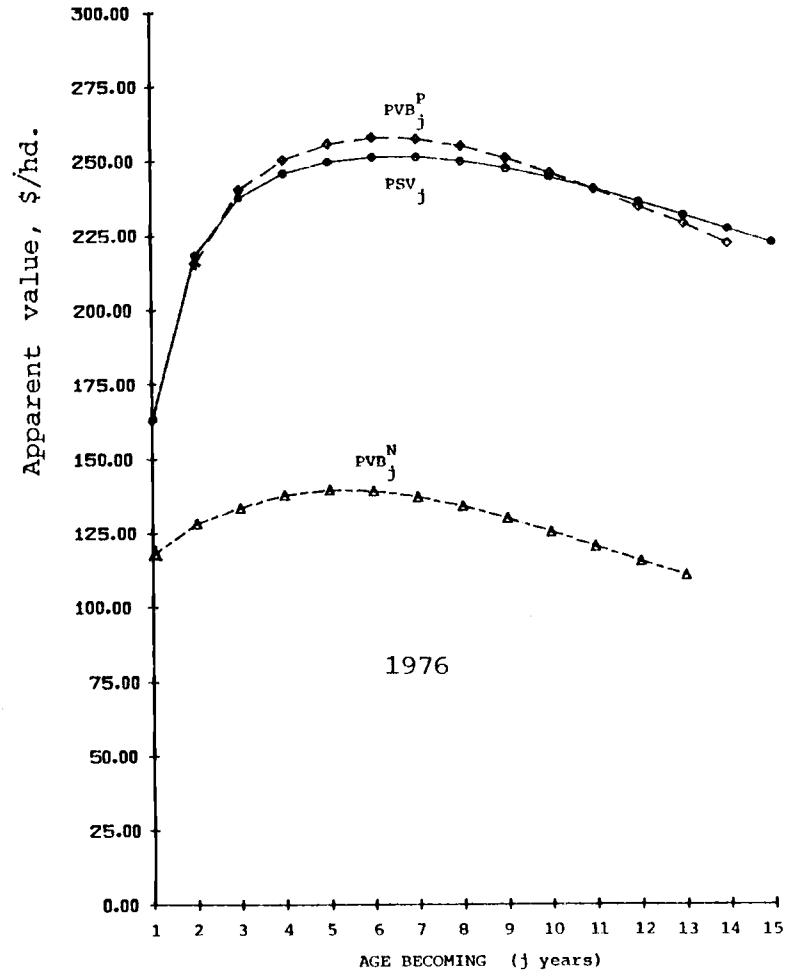
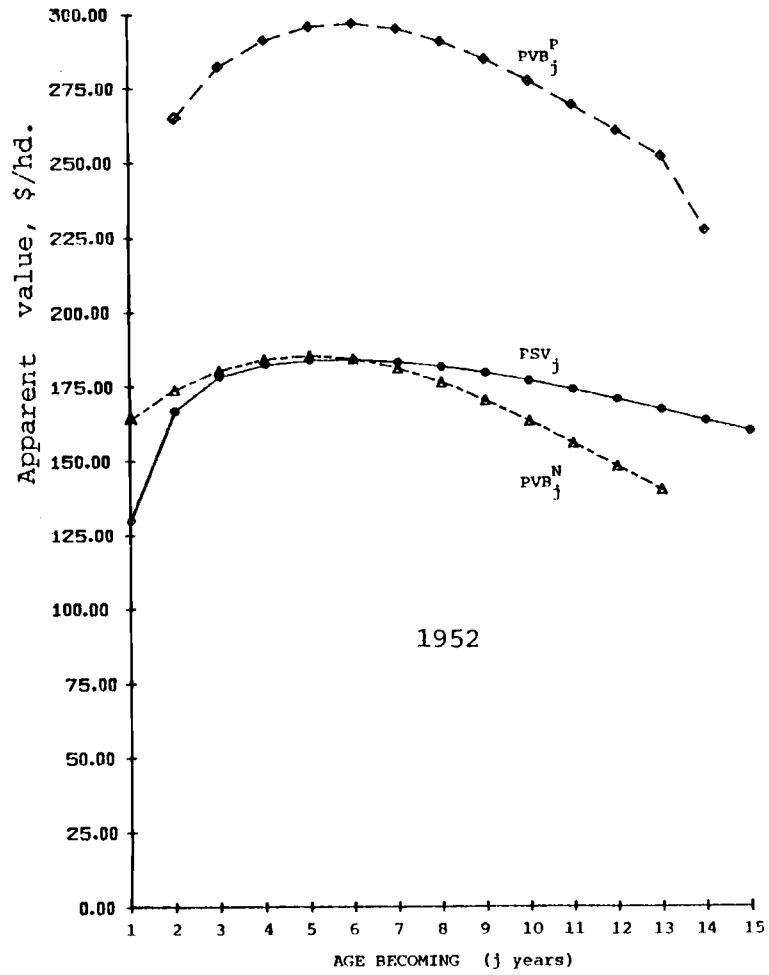

breeding values (PVB_j^N) only about half as high as their immediate slaughter salvage values (PSV_j).

The simulated cow values shown in Figure 5.2 explicitly indicate the wide range of "optimism" and "pessimism" which Walters (1965) mentioned as periodically seizing the cattle industry. In this display simulation run the maximum allowable planning horizon for retainment decisions was 2 years. Recall that in the case of pregnant cows becoming 14 years of age, the maximum planning horizon is limited to a single year. For that reason, a "kink" appears in the PVB_j^P curve for 1952; all younger cows are presumed to have 2 year planning horizons because their futures seem so bright. No "kink" appears in the PVB_j^P curve for 1978 since the future for all classes appears so bad that none are considered for more than a one year planning horizon.

Another point illustrated by Figure 5.2 is the great difference between apparent breeding values of pregnant and non-pregnant animals of the same age. This is due chiefly to the expectation of calf sales from the former in only one year.

Age Structure: Demographic Pulse

In the simulated path of age structure changes, shown in Figure 5.3, dramatic internal waves or pulses occur through time. These are due to the combined effects of variable recruitment of heifers and variable culling pressures across cow ages through time. Figure 5.3 may be compared with the U.S.D.A. figures on the beef cow inventory shown in Figure 1.1 at the beginning of this study. The

SIMULATED CUMULATIVE AGE STRUCTURE OF THE U.S. BEEF COW HERD, 1950-1978

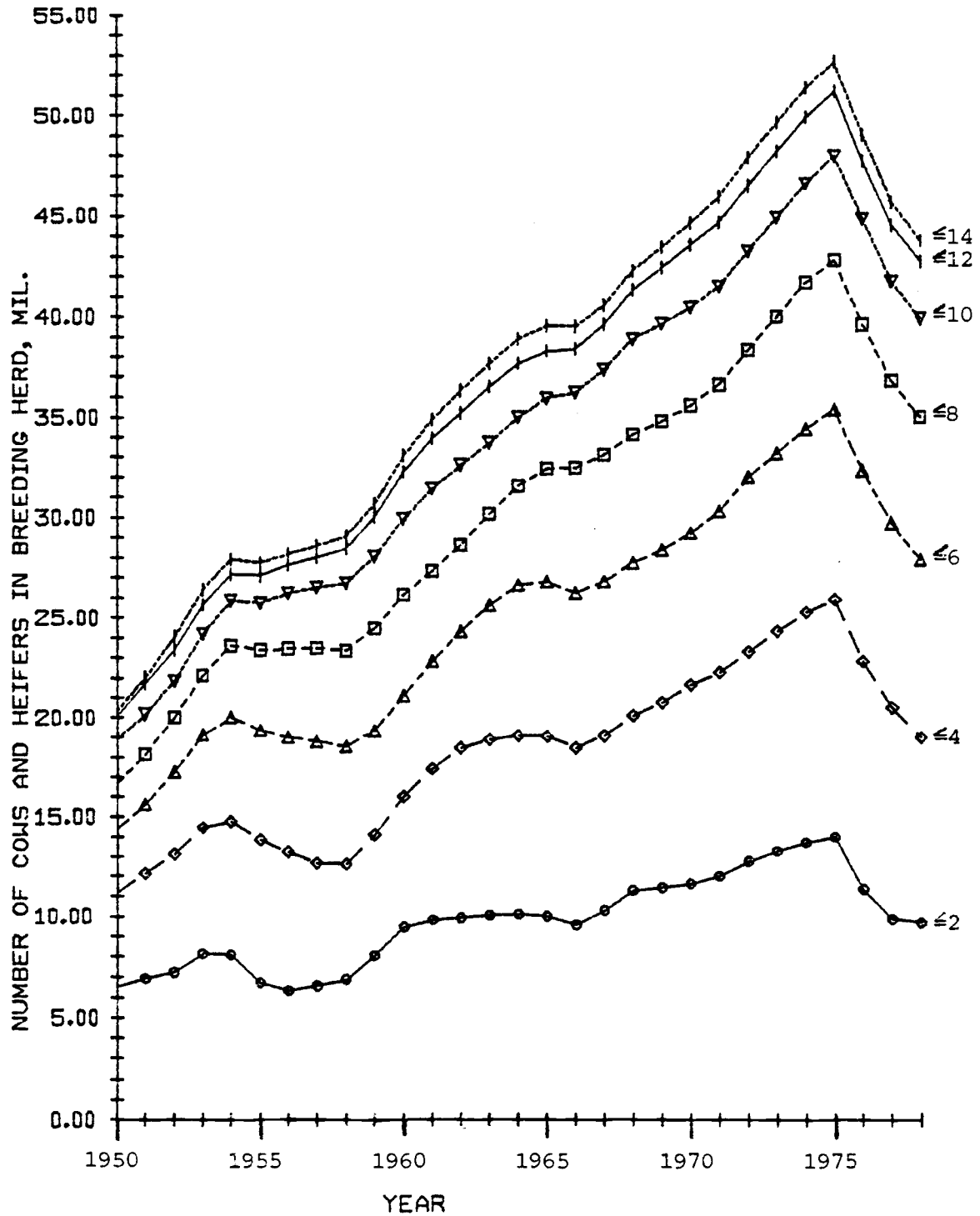

comparison will not be exact because weaned heifers kept for breeding are included in the age structure graph but not in the total cow inventory plot of Figure 1.1.

In the age structure graph, Figure 5.3, the youngest animals are on the bottom and the oldest on the top. Attrition, mainly by intentional culling but partly by death, is apparent as successively older age classes become smaller. The precipitous liquidation of the mid-seventies took cows from all age classes, according to the model, but not all in the same proportions.

In Figure 5.4, the data used to plot the numerical age structure graph have been transformed to percentage terms. In the proportional age structure graph, Figure 5.4, a feature barely visible in the numerical structure plot becomes boldly apparent. A "pulse" in the proportional age composition of the herd, very similar to that hypothesized in Figure 1.2 is simulated. Recruitment-year cohorts are indicated for two successions of heavy (cross-hatched cells) and light (empty cells) recruitment. The cross-hatched cell shown at 1950-51, is comprised of heifers 2 years old and younger recruited into the herd during a time of high cattle prices relative to costs. By 1962-63 representatives of those recruitment-cohorts remain in the herd as 12 to 14 year olds.

Referring still to Figure 5.4, the empty cell at 1955-56 represents heifers recruited during a time of much lower cattle prices than 5 years earlier. The simulated pattern shows a swelling in the proportions of cows in the middle-aged prime cows and constriction in the proportions of elderly cows, during such a period of belt-

FIGURE 5.4 SIMULATED AGE COMPOSITION OF THE U.S. BEEF COW HERD, 1950-1978, WITH RECRUITMENT-YEAR COHORTS

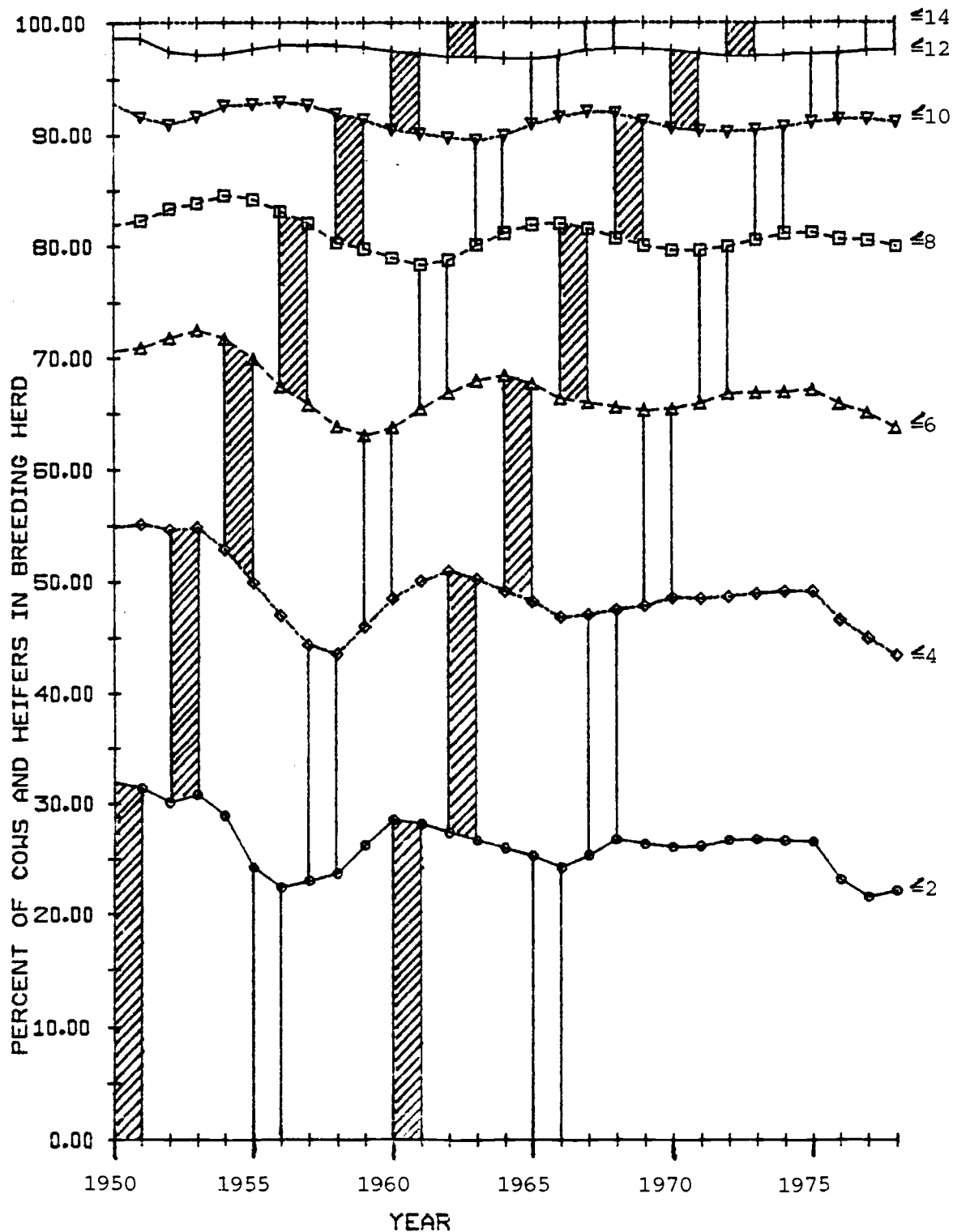

tightening. By 1960-61 the large middle-aged group of the mid-50's has grown old to swell the ranks of the elderly classes. The middle-aged classes comprise a considerably smaller proportion of the herd than did the same age class 5 years earlier.

The process portrayed as the "demographic pulse" is ponderously slow, almost glacial in its movement. Herd owners caught up in the distractions of current expenses, weekly and seasonal cattle price gyrations, could scarcely be expected to appreciate their contribution to the process. With only total cow numbers to deal with, government forecasters may also be forgiven for not having noticed this process, though it seems likely to be a contributing force in the annoyingly regular cattle cycle.

Conclusions

A search of the biological literature revealed strong indications that beef cows perform differently across ages. The major biological differences with economic importance are conception rates, health rates, body weights, calf weaning weights and calf survival rates.

The above biological features of cows in different age classes may be used in models of rational investment behavior by beef cow operators. Earlier firm level models have suffered from the assumption of incorrect biological parameters or management practices far removed from the ordinary. National models, due to real data limitations have unintentionally focused on ageless cow populations.

Simulation models may be used to organize the knowledge already at hand into powerful logical structures for tracing the probable consequences of our manipulation of system elements. The current

study has shown the likely aggregate consequences of investment response toward beef cows, a very peculiar form of productive capital.

The imperfect tracking behavior of the model, with respect to the four objective series, may be due to several factors. The annual budget generator may be too simply specified to capture the true historical aggregate beef cow variable cost history. The cost and price variables which drive the model may lack representativeness. Aggregation errors are undoubtedly present but of unknown dimensions. The "objective" series against which the simulated series are compared may also be in error. Especially suspect are the historical numbers of heifers recruited to the breeding herd.

Tax considerations have also been ignored. Some feel that these have in recent years become increasingly important. The model has not been specified to capture beef cow investment motives other than enterprise profit. Cow investments as tax shelters and inclusions on "hobby farms" for aesthetic gratification, have been ignored here.

Cow performance parameters are assumed to have remained constant over the study period, and across regions. The errors introduced by such simplification are also of unknown dimensions.

Questions of price formation, clearly an important element in the cattle cycle process, have been ignored in the present model. With the evidence at hand there is no support for an assertion that a "demographic pulse" causes cattle cycles or determines their length only that it very likely exists and is susceptible to further study.

A simulation run was made with parameters set to reflect the assumption that cows of all ages have the same performance levels.

The model's ability to track the objective historical series was, in some respects, better than in the display run. For example, an MPAD of 0.024 for cow inventories was shown, compared with 0.029 in the display run. Thus, the null hypothesis that differences across mature cow ages are of no importance in explaining beef cow investment behavior could not be rejected. In the "homogeneous cow" run, however, costs and revenue prospects were still distinguished between weaned heifers kept for breeding, pregnant and non-pregnant yearlings, and pregnant and non-pregnant cows. In all cases, as usual the greatest differences were due to the expectation of calf sales revenues for the pregnant animals.

With its few exogenous price and cost variables, simple management expectations and biological relationships, the model is able to track the historical numbers of beef cows and calves born quite well. The model is very simple in that it considers only the beef cow/calf sector. No information on dairy or other livestock sectors is used and the feedback mechanism through fed cattle and price formation is ignored. Such a biologically constrained investment reaction model may be most useful because of its simplicity.

Indications for Further Research

Both firm level and aggregate research are indicated. The surface has only been scratched with this study.

The author has spoken with farmers who mentioned having been surprised to find that a sizeable proportion of their cows in a given year are very old. It is possible for cattlemen to pay closer attention to their own herd age structures to avoid such surprises. Being conscious of age structure should allow more accurate projection of expected herd performance.

Animal scientists may make valuable contributions to knowledge of age effects by analysis of past herd records. By focusing on the attributes of age associated with economic efficiency, they may provide a more accurate biological picture than that given in Chapter 2. The truer the biological assumptions made by economists, the more useful their findings will be.

Prices and costs are exogenous in the present model. Price formation in the beef industry has long been studied. It is, therefore, possible to construct a combined model of price formation and beef cow investment response. Then projection of estimates could be made for the future, perhaps forecasting age structure situations which may precipitate large liquidations.

Current age structure estimates and forecasts may be derived and published regularly. Such information would be more useful to cattlemen than the too common reports of herd value based on appraisal of the entire cow inventory at current slaughter prices.

BIBLIOGRAPHY

- Anderson, Jock R., John L. Dillon, and Brian Hardaker. Agricultural Decision Analysis. The Iowa State University Press, Ames, Iowa. 1977.
- Aristotle. "History of Animals." Great Books of the Western World. Encyclopedia Britannica, Inc. William Benton, publisher. 1952.
- Arnold, G. W., and C. T. deWit, (Editors). Critical Evaluation of Systems Analysis in Ecosystems Research and Management. Centre for Agricultural Publishing and Documentation. Wageningen, The Netherlands. 1976
- Baker, A. L. and J. R. Quesenberry. "Fertility of Range Beef Cattle." Journal of Animal Science. Vol. 3, No. 1, February, 1944, pp. 78-87.
- Baldwin, K. D. S. Demography for Agricultural Planners. Development Research and Training Service, Policy Analysis Division, Food and Agriculture Organization of the United Nations, Rome, Italy. May, 1975.
- Bentley, Ernest, J. R. Waters, and C. R. Shumway. "Determining Optimal Replacement Age of Beef Cattle in the Presence of Stochastic Elements." Southern Journal of Agricultural Economics. Vol. 8, No. 2, 1976, pp. 13-18.
- Bentley, Ernest. Adaptive Planning for Texas Cattle Producers Facing Uncertain Prices. Unpublished Ph.D. dissertation, Agricultural Economics Department, Texas A & M University, May, 1979.
- Bray, J. O. Beef Productivity Increases in the Southeastern United States Since 1920. Food Research Institute Studies, Vol. VI, No. 1. Stanford University, Palo Alto, California. 1966.
- Breimyer, H. F. "Observations on the Cattle Cycle." Agricultural Economics Research. Vol. VII, No. 1, January, 1955, pp. 1-11.
- Brown, J. E., H. A. Fitzhugh, Jr., T. C. Cartwright, S. E. Carpenter, and E. K. Crouch. Algebraic Models for Describing Growth of Cows. Texas Ag. Experiment Station Progress Report 2979. Texas A & M University. 1971.
- Brown, W. F., J. W. Holloway, and W. T. Butts, Jr. "Patterns of Change in Mature Angus Cow Weight and Fatness During the Year." Journal of Animal Science. Vol. 51, No. 1, 1980, pp. 43-49.

- Buether, Arthur. Wheat farmer/cattleman. Sherman County, Oregon. Personal communication, January, 20, 1978.
- Burke, Louis R. "Effect of Age on Reproduction in Beef Cattle." Proceedings of the Annual Meeting of the Western Section of the American Society of Animal Production. Vol. 5, 1954, pp. 249-270.
- Burlakov, N. M., and D. I. Startsev (eds.). Cattle Husbandry, Vol 1, Breeding and Breeds of Cattle. Translated from Russian by Israel Program for Scientific Translations. Jerusalem, Israel. U.S. Dept. of Commerce, Clearinghouse for Federal Scientific and Technical Information. Springfield, Virginia 22151. 1961.
- Burmeister, C. A. "Cycles in Cattle Numbers." The Livestock and Meat Situation. U.S. Bureau of Agricultural Economics. March, 1949.
- Burnet, Steve. Wheat farmer/cattleman. Sherman County, Oregon. Personal communication, January 21, 1978.
- Burt, Oscar R. "Optimal Replacement Under Risk." Journal of Farm Economics. Vol. 47, No. 2, May, 1965, pp. 324-345.
- Carlson, Gary. Wheat farmer/cattleman. Sherman County, Oregon. Personal communication, January 21, 1978.
- Carpenter, J. A., H. A. Fitzhugh, Jr., J. E. Brown, and E. K. Crouch. Relationships Among Growth Curve Parameters and Measures of Productivity in Beef Cows. Texas Ag. Experiment Station Progress Report 2975, Texas A & M University. 1971.
- Castle, E. N., M. H. Becker, and F. J. Smith. Farm Business Management, the Decision Making Process. Second Edition. Macmillan Publishing Co., Inc., New York. 1972.
- Cattle-Fax. Cattle Economics Report. National Cattlemen's Association. July, 1978.
- Choi, Wonyoung. "The Cattle Cycle." European Review of Agricultural Economics. Mouton Publishers, The Hague, The Netherlands. Vol. 4, No. 2, 1977, pp. 119-136.
- Conable, Daniel B. "Changes in U.S. Meat Import Law." Foreign Agriculture. U.S.D.A. Supplement. July, 1980.
- Crockett, J. R. "Age and Reproduction." Factors Affecting Calf Crop, T. J. Cunha, A. C. Warnick and M. Koger (eds.). University of Florida Press, Gainesville, Florida. 1967.

- Crom, Richard J., and Wilbur R. Maki. "A Dynamic Model of a Simulated Livestock-Meat Economy." Agricultural Economics Research. Vol. 17, No. 3, July, 1965, pp.73-83.
- Crom, Richard J. A Dynamic Price-Output Model of the Beef and Pork Sectors. USDA/ERS Technical Bulletin 1426. Washington, D.C. September, 1970.
- Cunha, T.J., A.C. Warnick, and M. Koger. (eds.) Factors Affecting Calf Crop. University of Florida Press, Gainesville, Florida, 1967.
- Davis, Ronald. Cattleman/hay grower. Gilliam County, Oregon. Personal communication, February 10, 1978.
- DeGraff, Herrell. Beef Production and Distribution. University of Oklahoma Press, Norman, Oklahoma. 1960.
- Dent, J.B. and J.R. Anderson (Eds.) Systems Analysis in Agricultural Management. John Wiley and Sons, Australia Pty. Ltd. 1971.
- Dickerson, G. E., and H. A. Glimp. "Breed and Age Effects on Lamb Production of Ewes." Journal of Animal Science. Vol. 40, No. 3, March, 1975, pp. 397-408.
- Dillon, John L. The Analysis of Response in Crop and Livestock Production. Second Edition. Pergamon Press Inc., Elmsford, New York. 1977.
- Doran, M. H., A. R. C. Low, and R. L. Kemp. "Cattle as a Store of Wealth in Swaziland: Implications for Livestock Development and Overgrazing in Eastern and Southern Africa." American Journal of Agricultural Economics. Vol. 61, No. 1, February, 1979, pp. 41-47.
- Drovers Journal. August 1978. pp. 144-162.
- Economics, Statistics and Cooperatives Service, USDA. Costs of Producing Feeder Cattle in the United States--Final 1977, Preliminary 1978, and Projections for 1979. U.S. Government Printing Office, Wasington, D.C. 1979.
- Egbert, Alvin C., and Shlomo Reutlinger. "A Dynamic Long-Run Model of the Livestock-Feed Sector." Journal of Farm Economics. Vol. 47, No. 5, December, 1965, pp. 1289-1305.

- Ehrich, Rollo L. Economic Analysis of the United States Beef Cattle Cycle. Agricultural Experiment Station Science Monograph 1. University of Wyoming, Laramie, Wyoming. April, 1966.
- Ehrich, Rollo L., and M. Usman. Demand and Supply Functions for Beef Imports. Bulletin 604, Division of Ag. Economics, Ag. Exp. Station, University of Wyoming, Laramie, Wyoming. January, 1974.
- Elam, T. E. "Canadian Supply Functions of Livestock and Meat: Comment." American Journal of Agricultural Economics. Vol. 57, No. 2, May, 1975, pp. 364-65.
- Ensminger, M. E., M. W. Galgan, and W. L. Slocum. Problems and Practices of American Cattlemen. Washington Ag. Experiment Station Bulletin 562. December, 1955.
- Ensminger, M. E. Beef Cattle Science. Fifth Edition. The Interstate Printers and Publishers, Inc. Danville, Illinois. 1976.
- Erickson, Russel. Wheat farmer/cattleman. Gilliam County, Oregon. Personal communication, February 9, 1978.
- Everett, Rodney A., and F. James Vickery. "Commercial Horse Breeding as a Potential Alternative Grazing Use for South Australian Arid Rangelands." Proceedings of the First International Rangeland Congress, Donald N. Hyder (ed.). Denver, Colorado, August 14-18, 1978, pp. 588-591.
- Ezekiel, Mordecai. "The Cobweb Theorem." Quarterly Journal of Economics. Vol. 52, February, 1938.
- Farmbank Research and Information Service. "The Cattle Cycle: New Numbers." Insight, Vol. 3, No. 2, February, 1980.
- Fields, Michael J., and Alvin C. Warnick. "Factors Affecting Calf Crop Percentage." Southern Regional Beef Cow-Calf Handbook. SR1003. Institute of Food and Agricultural Science, University of Florida, Gainesville, Florida. 1974.
- Folwell, Raymond J. "A New Outlook at Demand Analysis for Beef: Comment." American Journal of Agricultural Economics. Vol. 51, No. 4, November, 1969, pp. 947-949.
- Folwell, Raymond J., and H. Shapouri. An Econometric Analysis of the U.S. Beef Sector. Technical Bulletin 89, Washington State University, Pullman, Washington. 1977.

- Franzmann, John R. "Cattle Cycles Revisited." Southern Journal of Agricultural Economics. Vol. 3, No. 1, December, 1971, pp. 69-76.
- Franzmann, John R., and Rodney L. Walker. "Trend Models of Feeder, Slaughter, and Wholesale Beef Cattle Prices." American Journal of Agricultural Economics. Vol. 54, No. 3, August, 1972, pp. 507-512.
- Freebairn, J. W., and G. C. Rausser. "Effects of Changes in the Level of U.S. Beef Imports." American Journal of Agricultural Economics. Vol. 57, No. 4, November, 1975, pp. 676-88.
- Fuller, W. A., and G. W. Ladd. "Dynamic Quarterly Model of the Beef and Pork Economy." Journal of Farm Economics. Vol. 43, Part 1, November, 1961, pp. 797-812.
- Gebremeskel, Tesfaye. Cow-calf Production and Marketing Decisions in East Texas: Application of Risk Constrained Linear Programming and Statistical Decision Theory. Unpublished Ph.D Thesis, Dept. of Ag. Economics, Texas A & M University. May, 1977.
- Gebremeskel, Tesfaye, and C. Richard Shumway. "Farm Planning and Calf Marketing Strategies for Risk Management: An Application of Linear Programming and Statistical Decision Theory." American Journal of Agricultural Economics. Vol 61, No. 2, May, 1979, pp. 363-370.
- Ginn, Bruce A. "Relationships Between Beef and Grain Prices." Economic and Production Problems of the Range Beef Industry. Proceedings of the Western Regional Extension Workshop, Salt Lake City, Utah. July 6-8, 1977.
- Gladwin, Christina H. A Heirarchical Theory of Choice. Unpublished monograph, Stanford University. Spring 1975.
- Gladwin, Christina H. "A View of the Plan Puebla: An Application of Hierarchical Decision Models." American Journal of Agricultural Economics. Vol. 58, No. 5, December, 1976. Proceedings Issue.
- Goodwin, Richard M. "Dynamical Coupling with Especial Reference to Markets Having Production Lags." Econometrica. Vol. 15, No. 3, July 1947, pp. 181-204.
- Gray, James R., and C. V. Plath. Economics of Adjusting to Drought on Eastern Oregon Cattle Ranches. Miscellaneous Paper 48. Agricultural Experiment Station, Oregon State University, Corvallis, Oregon. September, 1957.

- Gray, James R. Ranch Economics. The Iowa State University Press, Ames, Iowa. 1968.
- Greer, R. C., R. W. Whitman, and R. R. Woodward. "Estimation of Probability of Beef Cows Being Culled and Calculation of Expected Herd Life." Journal of Animal Science. Vol. 51, No. 1, July, 1980, pp. 10-19.
- Greer, R. C., R. W. Whitman, R. R. Woodward and W. A. Yager. Reasons for Culling Beef Cows and Estimates of the Proportion Culled for Each Reason. Bulletin 708. Montana Agricultural Experiment Station, Montana State University, Bozeman, Montana. January, 1979.
- Greiner, Thomas. Wheat farmer/cattleman. Gilliam, County, Oregon. Personal communication, February 9, 1978.
- Gruber, Josef, and Earl O. Heady. Econometric Analysis of the Cattle Cycle in the United States. Iowa Agricultural and Home Economics Experiment Station. Research Bulletin 564. July, 1968.
- Gustafson, R., R. Remmele, and C. Shaw. Livestock and Meat Situation. LMS-232. Economics, Statistics, and Cooperative Service, USDA, Washington, D.C. February, 1980.
- Halter, A. N., and G. W. Dean. Simulation of a California Range-Feedlot Operation. Giannini Foundation Research Report No. 282, California Agricultural Experiment Station, University of California and Giannini Foundation of Agricultural Economics. May, 1965.
- Halter, A. N., and G. W. Dean. "Use of Simulation in Evaluating Management Policies Under Uncertainty: Application to a Large Scale Ranch." Journal of Farm Economics. Vol. 47, No. 3. 1965, pp. 557-573.
- Halter, A. N., Stanley F. Miller, Richard De Jongh, and Hugo Estrada R. "Application of Systems - Simulation in the Venezuelan Cattle Industry." Agricultural Systems. Applied Science Publishers Ltd., England. Vol. 1, 1976, pp. 139-162.
- Hardie, William. Wheat farmer/cattleman. Gilliam County, Oregon. Personal communication, February 9, 1978.
- Harmsen, W. L. "Beef and Veal Production in the Netherlands." The Early Calving of Heifers and Its Impact on Beef Production, J. C. Tayler (ed.). Department of Cattle Experiments, National Institute of Animal Science, Copenhagen, Denmark. 1975, pp. 28-34.

- Harrison, Raymond. Wheat farmer/cattleman. Gilliam County, Oregon. Personal communication, February 9, 1978.
- Hayenga, M. L., T. J. Manetsch, and A. N. Halter. "Computer Simulation as a Planning Tool in Developing Economies." American Journal of Agricultural Economics. Vol. 50, No. 5, December, 1978, pp. 1755-1759.
- Helmers, Glenn A. "Effect of Lending Strategy and the Cattle Price Cycle on Growth of Ranch Firms." Proceedings of the 47th Annual Meeting of the Western Agricultural Economics Association. Moscow, Idaho. July 24-26, 1974.
- Hertzler, Greg, and James H. Cothorn. "The Sub-optimality of the Beef Cycle". A paper presented at the American Agricultural Economics Association Annual Meeting. Pullman, Washington. August 1, 1979.
- Hillier, F.S. and G.L. Lieberman. Operations Research. Second Edition. Holden-Day, Inc. San Francisco, California. 1974.
- Hinchy, M. "The Relationship Between Beef Prices in Export Markets and Australian Saleyard Prices." Quarterly Review of Agriculture Economics. Vol. XXXI, Nos. 2-3, April/July, 1978, pp. 83-105.
- Hirshleifer, J. Investment, Interest, and Capital. Prentice-Hall, Inc., Englewood Cliffs, N.J. 1970.
- Holmes, Robert. Wheat farmer/cattleman. Sherman County, Oregon. Personal communication, January 20, 1978.
- Hopkins, John A., Jr. A Statistical Study of the Prices and Production of Beef Cattle. Research Bulletin 101. Iowa Agricultural Experiment Station. December, 1926.
- Hultz, Fred S. Range Beef Production in the Seventeen Western States. John Wiley & Sons, Inc., New York. 1930.
- Jacobs, Victor E. "The Beef Cattle Industry: Structure, Scope, Movement, and Adjustment Mechanisms." Farm Management Newsletter. FM 77-3 Beef Cow Forage Series #29. Cooperative Extension Service, University of Missouri. Columbia, Missouri. March 30, 1977.
- Jacobs, Victor E. "Cows vs. Steers: The Cornerstone Decision of the Beef Cattle Industry." Farm Management Newsletter. FM 77-6. Beef Cow Forage Series #30. Cooperative Extension Service, University of Missouri. Columbia, Missouri. April 22, 1977.

- Jacobs, Victor E. "Cattle Rally: Short or Sharp? Or Extended?" Commodities. June 1978. pp. 23-25.
- Jacobs, Victor E., and Carrol L. Kirtley. "M.I.R. 1977 Costs and Returns in Feeder Cattle Production." Farm Management Newsletter. FM 78-12. Cooperative Extension Service, University of Missouri. Columbia, Missouri. November 17, 1978.
- Jacobs, Victor E. "Cattle Feeding and the Cattle Cycle." Mimeo. Dept. of Agricultural Economics, University of Missouri, Columbia. 1979.
- Jarvis, Lovell S. "Cattle As Capital Goods and Ranchers As Portfolio Managers: An Application to the Argentine Cattle Sector." Journal of Political Economy. Vol. 82, No. 3. May/June, 1974. pp. 489-520.
- Jaske, Michael R. Systems Simulation Modeling of a Beef Cattle Enterprise to Investigate Management Decision Making Strategies. Unpublished Ph.D. Dissertation. Department of Electrical Engineering and Systems Science, Michigan State University. 1976.
- Jenkins, Keith B., and Albert N. Halter. A Multi-Stage Stochastic Replacement Decision Model, Application To Replacement of Dairy Cows. Technical Bulletin 67. Agricultural Experiment Station, Oregon State University. Corvallis, Oregon. 1963.
- Johnston, J. Econometric Methods. 2nd Edition. McGraw-Hill Book Company. New York. 1972.
- Jones, Emrys. Human Geography, An Introduction to Man and His World. Frederick A. Praeger, Publishers. New York, New York. 1965.
- Kay, Ronald D., and Edward Rister. "Income Tax Effects on Beef Cow Replacement Strategy." Southern Journal of Agricultural Economics. Vol. 9, No. 1, July, 1977, pp. 169-172.
- Keith, K., and W. D. Purcell. The Beef Cycle of the 1970's: Analysis, Behavioral Dimensions, Outlook, and Projections. Oklahoma Agr. Exp. Sta. Bul. B-721. Stillwater, Oklahoma. March, 1976.
- Keith, K., and W. D. Purcell. "Possible Implications of Voids in the USDA Cattle Slaughter Data." American Journal of Agricultural Economics. Vol. 58, No. 3, August, 1976, pp. 568-571.

- Keyfitz, Nathan, and Wilhelm Flieger. Population, Facts, and Methods of Demography. W. H. Freeman and Company, San Francisco. 1971.
- Kim, Han Joo. An Analysis of Investment in the United States Beef Cattle Industry. Unpublished Ph.D. Thesis. Department of Agricultural Economics, Oregon State University. Corvallis, Oregon. 1970.
- Klir, George J. An Approach to General Systems Theory. Van Nostrand Reinhold Company, New York. 1969.
- Koger, M. "Selection and Culling in Florida." Factors Affecting Calf Crop, T. J. Cunha, et. al. (eds.). University of Florida Press, Gainesville. 1967, pp. 239-243.
- Koger, M., and A. C. Warnick. "Various Pasture Programs." Factors Affecting Calf Crop, T. J. Cunha, et. al. (eds.). University of Florida Press, Gainesville. 1967, pp. 98-101.
- Koutsoyiannis, A. Theory of Econometrics. Second Ed. Barnes And Noble, Publishers. 1977.
- Kulshreshtha, S. N., and A. G. Wilson. "An Open Econometric Model of the Canadian Beef Cattle Sector." American Journal of Agricultural Economics. Vol. 54, No. 1, February, 1972, pp. 84-91.
- Kulshreshtha, S. N., and A. G. Wilson. "Long Swing Hypothesis For Cattle and Hog Output and Prices in Canada: An Application of Spectral Analysis." Canadian Journal of Agricultural Economics. Vol. 22, No. 1, February, 1974, pp. 12-25.
- Kuznets, Simon, and Dorothy S. Thomas (Eds.). Population Redistribution and Economic Growth, United States, 1870-1950. Vol. 1 Methodological Considerations and Reference Tables. The American Philosophical Society, Philadelphia, Pennsylvania. 1957.
- Larson, A. B. "The Hog Cycle as Harmonic Motion." Journal of Farm Economics. Vol. 46, No. 2, May, 1964, pp. 375-385.
- Lasley, John. F., and Ralph Bogart. Some Factors Influencing Reproductive Efficiency of Range Cattle Under Artificial Breeding Conditions. Missouri Agricultural Experiment Station. Research Bulletin 376. 1943.
- Lin, Tsae-Yun. An Application of Transfer Function and Econometric Procedures to Employment Impact Analysis: Grant County, Oregon. Unpublished M.S. Thesis. Dept. of Agricultural and Resource Economics. Oregon State University, Corvallis. 1980.

- Long, C. R., T. C. Cartwright, and H. A. Fitzhugh, Jr. "Systems Analysis of Sources of Genetic and Environmental Variation in Efficiency of Beef Production: Cow Size and Herd Management." Journal of Animal Science. Vol. 40, No. 3, March, 1975, pp. 409-420.
- Long, C. R., H. A. Fitzhugh, Jr., and T. C. Cartwright. Factors Affecting Efficiency of Beef Production. Texas Ag. Experiment Progress Report 2981. College Station: Texas A & M University. 1971.
- Longworth, J.W. and T. Bos. "The C.P.I.: A Simple Explanation and Some Words of Warning." Review of Marketing and Agricultural Economics. Vol. 46, No. 1, April 1978. pp. 21-36.
- Lorie, James H. "Causes of Annual Fluctuations in the Production of Livestock and Livestock Products." Studies in Business Administration. Vol. 17, No. 1. A supplement to the Journal of Business. University of Chicago. Vol. 20, April, 1947.
- Lotka, Alfred J. Elements of Mathematical Biology. Dover Publications, Inc., New York. 1956.
- Maki, W. R. "Decomposition of Beef and Pork Cycles." Journal of Farm Economics. Vol. 44, No. 3. August, 1962. pp. 731-743.
- Manetsch, T. J., M. L. Hayenga, A. N. Halter, et. al. A Generalized Simulation Approach to Agricultural Sector Analysis, with Special Reference to Nigeria. Michigan State University. East Lansing, Michigan. November 30, 1971.
- Marshall, R. G. Variations in Canadian Cattle Inventories and Marketing. Dept. of Agricultural Economics, Ontario Agricultural College. Guelph, Ontario. June, 1964.
- Martin, Larry, and Karl D. Meilke. "Implications of International Trade on Resources for Animal Production." A paper presented at the annual meeting of the American Association for the Advancement of Science. Houston, Texas. January, 1979.
- Mathur, V.K. and H.S. Rosen. "Regional Employment Multiplier: A New Approach." Land Economics. Vol. 50, 1974. pp. 93-96.
- Matsuda, Tomoyoshi. "A Spectral Analysis of Beef Cycle." The Nokei Ronso. (The Review of Agricultural Economics). Vol. 35. Hokkaido University, Sapporo, Japan. March, 1979, pp.14-32.

- McCoy, John H. Livestock and Meat Marketing. The AVI Publishing Company Inc. Westport, Connecticut. 1972.
- Metzler, L. A. "The Nature and Stability of Inventory Cycles." Review of Economics and Statistics. August, 1941, pp. 113-129.
- Miller, Stanley F., and Albert N. Halter. "Systems-Simulation in a Practical Policymaking Setting: The Venezuelan Cattle Industry." American Journal of Agricultural Economics. Vol. 55, 1973, pp. 420-432.
- Minish, Gary L., and Danny G. Fox. Beef Production and Management. Reston Publishing Company, Inc. Reston, Virginia. 1979.
- Minsky, T., and S. Shellenberger. "Rare Beef; Despite High Prices for Meat, Cattlement Aren't Producing More." The Wall Street Journal. Vol. CIII, No. 19, July 28, 1980.
- Mobley, Vernon. Wheat farmer/cattleman. Wasco County, Oregon. Personal communication, June 30, 1977.
- Mueller, Robert G. Costs of Cow-Calf Ranching in Northern Interior Washington. Washington State University. Agricultural Experiment Station, Circular 481. 1969.
- National Research Council. Prenatal and Postnatal Mortality in Cattle. Publication 1685. National Academy of Sciences. Washington, D.C. 1968.
- Nerlove, M. "Adaptive Expectations and Cobweb Phenomena." Quarterly Journal of Economics. May, 1958, pp. 227-240.
- Nordquist, A., and H. Ottoson. The Beef Cycle. Nebraska Agricultural Experiment Station and USDA Cooperating. E. C. 65-827. 1965.
- Oppenheimer, Harold L. Cowboy Arithmetic, Cattle as an Investment. The Interstate Printers and Publishers, Inc. Danville, Illinois. 1961.
- Oppenheimer, Harold L., and James D. Keast. Cowboy Litigation, Cattle and the Income Tax. 2nd Ed. The Interstate Printers & Publishers, Inc. Danville, Illinois. 1972.
- Ospina, Enrique, and C. Richard Shumway. Modeling Short-run Beef Supply Response. Departmental Information Report: DIR 78, SP-3. Department of Agricultural Economics, Texas A & M University. College Station, Texas. October, 1978.

- Overton, W. Scott. "Definition of Ecosystems--A Systems Theoretic Approach." Proceedings of the American Phytopathological Society. Vol. 1. 1974. Pub. by the American Phytopathological Society, Inc. 3340 Pilot Knob Road, St. Paul, Minnesota, 55121.
- Overton, W. Scott. "The Ecosystem Modeling Approach in the Coniferous Forest Biome." Chapter Six in: Systems Analysis and Simulation in Ecology. Vol. III. Academic Press, Inc. New York. 1975.
- Overton, W. Scott. "A Strategy of Model Construction." Chapter Three in: Hall, Charles A. S., and John W. Day, Jr. (eds.). Ecosystem Modeling in Theory and Practice: An Introduction With Case Histories. John Wiley & Sons, Inc., Publisher. 1977.
- Overton, W. Scott and Curtis White. "Evolution of a Hydrology Model - An Exercise in Modelling Strategy." International Journal of General Systems. Vol. 4, 1978. pp. 89-104.
- Paulsen, A., T. Mann, A. Rahn, G. Futrell, and G. Ladd. A Quarterly Model of the Beef, Pork, Sheep, Broiler and Turkey Sectors. Economic Report Series, No. 6, Department of Economics, Iowa State University, Ames, Iowa. 1973.
- Perrin, R. K. "Asset Replacement Principles." American Journal of Agricultural Economics. Vol. 54, No. 1, February, 1972, pp. 60-67.
- Pope, L. S. "Commercial Beef Production in the United States." Chapter One in: O'Mary, C.C. and I. A. Dyer (eds.). Commercial Beef Cattle Production. 2nd Edition. Lea & Febiger. Philadelphia, Pennsylvania. 1978.
- Pope, L. S. "Winter Feeding and Reproduction in Cows." Factors Affecting Calf Crop, T. J. Cunha, et. al. (eds.). University of Florida Press, Gainesville. 1967a, pp. 32-43.
- Pope, L. S. "Age at First Calving and Performance." Factors Affecting Calf Crop, T. J. Cunha, et. al. (eds.). University of Florida Press, Gainesville. 1967b, pp. 273-279.
- Potter, Ermine L. Western Live-Stock Management. The Macmillan Company. New York. 1930.
- Powers, Terry A. HERDSIM Simulation Model User Manual. Project Methodology Unit. Economic and Social Development Department. Inter-American Development Bank. Washington, D. C. February, 1975.

- Preston, T. R., and M. B. Willis. Intensive Beef Production. Pergamon Press. Oxford, England. 1970.
- Reeves, George Wheatley. Price Stabilization, Bilateral Trade and Institutional Constraints: The Case of Beef in Australia and The United States. Unpublished Ph.D. Dissertation. Department of Agricultural Economics. University of California, Davis. 1980.
- Reutlinger, Shlomo. "Short-Run Beef Supply Response." Journal of Farm Economics. Vol. 48, No. 4, Part 1, November, 1966, pp. 909-919.
- Rietmann, Van. Wheat farmer/cattleman. Gilliam County, Oregon. Personal communication, January 19, 1978.
- Riley, Jim. "Survival in the Mad, Mad, Mad World of the Cattle Cycle." A paper presented at The Range Cow Research Center, Oklahoma State University. October 24, 1979.
- Rogers, LeRoy F. Replacement Decisions for Commercial Beef Herds. Washington Agricultural Experiment Station, Bulletin 736. College of Agriculture, Washington State University. Pullman, Washington. 1971.
- Rogers, LeRoy F. "Economics of Replacement Rates in Commercial Beef Herds." Journal of Animal Science. Vol. 34, No. 6, 1972, pp. 921-925.
- Romita, A. "Some Considerations on the Beef Situation in Italy." The Early Calving of Heifers and Its Impact on Beef Production, J. C. Tayler (ed.). Department of Cattle Experiments, National Institute of Animal Science. Copenhagen, Denmark. 1975, pp. 25-27.
- Rosen, H.S. and V.K. Mathur. "An Econometric Technique Versus Traditional Techniques for Obtaining Regional Employment Multipliers: A Comparative Study." Environment and Planning. Vol. 5, 1973. pp. 273-282.
- Schumpeter, Joseph A. Business Cycles, a Theoretical, Historical, and Statistical Analysis of the Capitalist Process. McGraw-Hill Book Company, Inc. New York. 1939.
- Schwab, G. D. A Computerized Decision-Making Model for the Beef/Forage Enterprise. Unpublished Ph.D. Dissertation. Department of Agricultural Economics. Purdue University. 1974.
- Shirk, Gertrude. "The 9-Year Cycle -- How it Came Out." Cycles. Vol XXVI, No. 2. March 1975. pp. 29-32.

- Siegmund, O. H. (ed.). The Merck Veterinary Manual. Third Edition. Merck and Co., Inc. Rahway, New Jersey. 1967.
- Stimac, Jerry Lynn. A Model Study of a Plant-Herbivore System. Unpublished Ph.D Thesis. Dept. of Entomology, Oregon State University, Corvallis, 1977.
- Stonaker, H. H. Breeding for Beef. Bulletin 501-S. Experiment Station, Colorado State University. Fort Collins, Colorado. December, 1958.
- Suttor, Richard E., and Richard J. Crom. "Computer Models and Simulation." Journal of Farm Economics. Vol. 46, No. 5, December, 1965, pp. 1341-1350.
- Tatum, Robert. Wheat farmer/cattleman. Sherman County, Oregon. Personal communication, January 20, 1978.
- Temple, R. S. (1967) "Reproductive Performance in the South" Cunha, T. J., et al (eds). Factors Affecting Calf Crop. University of Florida Press, Gainesville, 1967. pp. 15-26.
- Theil, Henri. Applied Economic Forecasting. North Holland Publishing Company. Amsterdam, The Netherlands. 1966.
- Thomlinson, Ralph. Population Dynamics: Causes and Consequences of World Demographic Change. Random House, New York, N.Y. 1976.
- Tiegen, Lloyd D. A Linked Model for Wheat, Feed Grain, and Livestock Sectors of the U.S. Working paper, Commodity Economics Division, E.R.S., U.S.D.A. Spetember, 1977.
- Tinbergen, J. "On the Theory of Business Cycle Control." Econometrica. Vol. 6, No. 1. January, 1938. pp. 22-39.
- Tinbergen, J., and J. J. Polak. The Dynamics of Business Cycles. The University of Chicago Press. Chicago, Illinois. 1950.
- Tinbergen, J. "Reformation of Current Business Cycle Theories as Refutable Hypotheses," in: Proceedings of the Conference on Business Cycles. National Bureau of Economic Research. New York, N.Y. 1951. pp. 131-140.
- Trapp, James N., and Clyde S. King. "Cow Culling and Replacement Strategies for Cyclical Price Conditions." Oklahoma Current Farm Economics. Vol. 52, No. 4. Division of Agriculture, Oklahoma State University, Stillwater, Oklahoma. 1979, pp. 3-11.

- Trebeck, D. B., and J. B. Hardaker. "The Integrated Use of Simulation and Stochastic Programming For Whole Farm Planning Under Risk." Australian Journal of Agricultural Economics. Vol. 16, No. 2, 1972, pp. 115-126.
- Trieweiler, John E., and Donald B. Erikson. South Dakota Farm & Home Research. Agricultural Experiment Station, South Dakota State University. Brookings, South Dakota. Vol. 17, No. 2, Spring, 1966.
- Trueman, Richard E. An Introduction to Quantitative Methods for Decision Making. Second Edition. Holt, Rinehart and Winston, New York. 1974.
- Tryfos, Peter. "Canadian Supply Functions of Livestock and Meat." American Journal of Agricultural Economics. Vol. 56, No. 1, February, 1974, pp. 107-113.
- U.S.D.A. Agricultural Statistics. Various issues, 1950 to 1979.
- U.S.D.A., E.S.S., T-DAM Data Bank Logical Group, FGSA. A magnetic tape file of T-DAM records in archive format. 1979.
- U.S.D.A., Livestock and Meat Situation. November, 1962. pp. 11-14.
- U.S. Meat Animal Research Center. Germ Plasm Evaluation Program, Progress Report No. 1. ARS-NC-13, Agricultural Research Service, USDA. March, 1974.
- U.S. Meat Animal Research Center. Germ Plasm Evaluation Program, Progress Report No. 2. ARS-NC-22, Agricultural Research Service, USDA. April, 1975.
- U.S. Meat Animal Research Center. Evaluating Germ Plasm for Beef Production, Cycle 1, Progress Report No. 3. ARS-NC-41, Agricultural Research Service, USDA. April, 1976.
- U.S. Meat Animal Research Center. Germ Plasm Evaluation Program, Progress Report No. 4. ARS-NC-48, Agricultural Research Service, USDA. June, 1976.
- U.S. Meat Animal Research Center. Germ Plasm Evaluation Program, Progress Report No. 5. ARS-NC-55, Agricultural Research Service, USDA. June, 1977.
- U.S. Meat Animal Research Center. Germ Plasm Evaluation Program, Progress Report No. 6. ARM-NC-2, Agricultural Reviews and Manuals, Science Education Administration, USDA. December, 1978.

- U.S. Meat Animal Research Center. Germ Plasm Evaluation Program, Progress Report No. 7. ARM-NC-6, Agricultural Reviews and Manuals, Science and Education Administration, USDA. July, 1979.
- Uvacek, Edward, Jr. Economic Trends in Texas Cattle Feeding. Texas Agricultural Experiment Station Bulletin, B-1055. Texas A&M University. College Station, Texas. August, 1966.
- Uvacek, Edward, Jr. "A New Look at Demand Analysis for Beef." American Journal of Agricultural Economics. Vol. 50, No. 5, December, 1968, pp. 1501-1506.
- Uvacek, Edward, Jr. "New Approaches Needed in Applied Meat-Animal Research." American Journal of Agricultural Economics. Vol. 50, No. 5, December, 1968, pp. 1750-1754.
- Uvacek, Edward, Jr. "A New Look at Demand Analysis for Beef: Reply." American Journal of Agricultural Economics. Vol. 51, No. 4, November, 1969, pp. 949-952.
- Valdes, Alberto, and David L. Franklin. "Evaluation of Design Parameters for Cattle Production in the Columbian Llanos." Chapter Six in Valdes, A., G. M. Scobie, and J. L. Dillon (Eds.). Economics and the Design of Small-Farmer Technology. Iowa State University Press. Ames, Iowa. 1979.
- Vielrose, Egon. Elements of the Natural Movement of Population. Pergamon Press. New York. 1965.
- Voorhies, E. C., and Koughan, A. B. Economic Aspects of the Beef Cattle Industry. Bulletin 461. California Agricultural Experiment Station. November, 1928.
- Vrooman, C. W. "Weaners, Yearlings, or Twos." Journal of Farm Economics. Vol. 38, No. 2, May, 1956, pp. 603-606.
- Wallace, T. D., and G. G. Judge. Econometric Analysis of the Beef and Pork Sectors of the Economy. Technical Bulletin T-75. Experiment Station, Oklahoma State University. August, 1958.
- Walters, Forrest. "Predicting The Beef Cattle Inventory." Agricultural Economics Research. Vol. 17, No. 1, January, 1965, pp. 10-18.
- Waugh, F. V. "Cobweb Models." Journal of Farm Economics. Vol. 46, No. 4, November, 1964, pp. 732-750.

- Weis, G. Stock Raising in The Northwest, 1884. Translated from French, with a historical note, by Herbert O. Brayer. The Branding Iron Press. Evanston, Illinois. 1951.
- Wheeler, Richard O. Optimum Cattle Inventory Systems Under Conditions of Certainty and Uncertainty--Southern Oregon. Unpublished Ph.D. Thesis. Department of Agricultural Economics, Oregon State University. Corvallis, Oregon. 1968.
- White, Curtis. A Comparison of FLEX With Other Model Simulation Systems. (Mimeo) Earth Systems Modeling, Ltd., Corvallis, Oregon, 97330. August, 1977.
- White, Curtis, and W. Scott Overton. Users Manual for the FLEX2 and FLEX3 Model Processors for the FLEX Modelling Paradigm. Forest Research Laboratory, School of Forestry, Oregon State University. Corvallis, Oregon. 1977.
- Whitley, Carol E. Production and Marketing Strategies for Eastern Oregon Rangeland Cattle Producers, 1968 through 1978. Unpublished M.S. Thesis. Dept. of Agricultural and Resource Economics. Oregon State University, Corvallis. 1979.
- Williams, Willard. F., and Thomas T. Stout. Economics of the Livestock-Meat Industry. The Macmillan Company, New York. 1964.
- Wilson, Louise L. Catalogue of Cycles, Part 1 - Economics. Foundation for the Study of Cycles, Inc. Pittsburgh, Pennsylvania. 1964.
- Yager, W.A., R.C. Greer, and O.R. Burt. "Optimal Policies for Marketing Cull Beef Cows". American Journal of Agricultural Economics. Vol. 62. No. 3. August 1980. pp. 456-467.
- Yanagida, John F., and Roger K. Conway. Annual Livestock Model of the United States. National Economic Division, Economics, Statistics, and Cooperative Service, USDA, Washington, D.C. January, 1980.
- Yotopoulos, Pan A. "From Stock to Flow Capital Inputs for Agricultural Production Functions: A Microanalytic Approach." Journal of Farm Economics. Vol. 49, No. 2, May, 1967, pp. 476-495.

APPENDIX A

FLEXFORM

FLEXFORM

AUGUST 1981

Thomas L. Nordblom, Dept. of Ag. and Resource Econ., Oregon State University

TITLE: BEEF COW VALUE AND DEMOGRAPHY MODEL: U.S. 1950 - 1978

PURPOSE: To provide a basis for expressing and testing the hypothesis that the historical patterns of beef cow herd accumulations and liquidations (the cattle cycle) have been related to investment incentive differences across cow ages through time, resulting each year in changes in herd age structure, performance and potentials for adjustment in subsequent years.

TIME RESOLUTION: one year (beginning with post-weaning/culling inventories each year)

STRUCTURE: see GROSS FLOWCHART, FUNCTION CATALOG, and BEEF COW DEMOGRAPHY MODEL FLOWCHART on

following pages. FLEXFORM CONTENTS: $x_{i,j}$ = state variables
 z_i = annual variable inputs
 $m_{i,j}$ = memory variables
 $g_{i,j}$ = intermediate functions
 $f_{i,j}$ = FLUX functions (to update state variables)
 $Y_{i,j}$ = output functions
 b_i = parameter list

BEEF COW VALUE AND DEMOGRAPHY MODEL: GROSS FLOW CHART

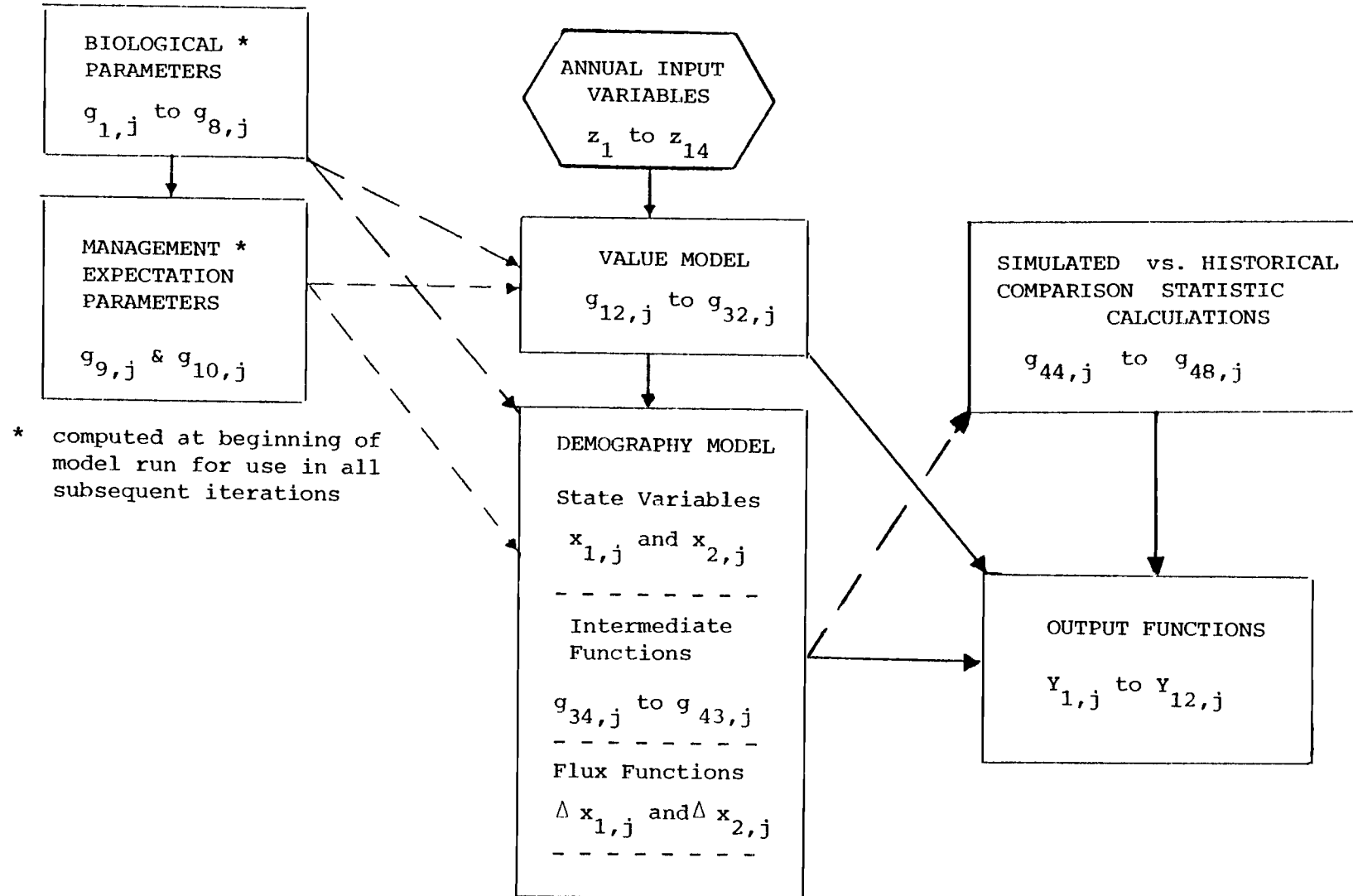

BEEF COW VALUE AND DEMOGRAPHY MODEL
FUNCTION CATALOG

FUNCTION LIST: BIOLOGICAL AND
MANAGEMENT EXPECTATION PARAMETERS

BIOLOGICAL PARAMETERS:

- $g_{1,j}$ = conception rates, by cow age
- $g_{2,j}$ = unimpaired health rates, by cow age
- $g_{3,j}$ = cow survival rates, by cow age
- $g_{4,j}$ = cow culling weights, by cow age
- g_5 = maximum cow body weight
- $g_{6,j}$ = calf weaning weights, by cow age
- g_7 = weaning weight of a heifer kept for breeding
- $g_{8,j}$ = calf survival rates, by cow age

MANAGEMENT EXPECTATION PARAMETERS:

- $g_{9,j}$ = expected retainment rates, by cow age
- $g_{10,j}$ = expected culling rates, by cow age

BEEF COW VALUE MODEL FUNCTION LIST

- $g_{12,1}$ = Expected future feeder steer price
- $g_{12,2}$ = Expected future utility cow price
- $g_{13,j}$ = Expected future cull salvage value (FSV_j)
- $g_{14,j}$ = Present cull salvage values (FSV_j)
- g_{15} = Interest charge factor
- g_{16} = Costs common to all budgets
- g_{17} = Cost budget for heifers kept for breeding (HKB's)
- g_{18} = Costs common to yearling heifers
- g_{19} = Cost budget for pregnant yearling heifers
- g_{20} = Cost budget for non-pregnant yearling heifers
- g_{21} = Costs common to cows, aged 3 years and over
- g_{22} = Cost budget for pregnant cows
- g_{23} = Cost budget for non-pregnant cows
- g_{24} = Net annual revenues, non-pregnant classes
- g_{25} = Net annual revenue, pregnant classes
- g_{26} = Discount factor for present value calculations
- $g_{27,j}$ = Expected final culling age decisions
- $g_{28,j}$ = FVB_j^P calculations
- $g_{29,j}$ = $FV_j^P = FVB_j^P / FSV_j$ calculations
- $g_{30,j}$ = $V_j^P = FVB_j^P / PSV_j$ calculations
- $g_{31,j}$ = FVB_j^N calculations
- $g_{32,j}$ = $V_j^N = FVB_j^N / PSV_j$ calculations

DEMOGRAPHY MODEL FUNCTION LIST

STATE VARIABLES

- $x_{1,1}$ = Weaned heifers not kept for breeding
- $x_{1,j}$ = Post-culling inventories of pregnant cows (j = 2 to 14)
- $x_{2,j}$ = Post-culling inventories, non-pregnant heifers and cows (j = 1 to 13)

INTERMEDIATE FUNCTIONS

- $g_{34,j}$ = Pre-culling inventories of pregnant animals
- $g_{35,j}$ = Pre-culling inventories of non-pregnant animals
- $g_{37,j}$ = Proportions of pregnant animals to be retained
- $g_{38,j}$ = Proportions of non-pregnant animals to be retained
- $g_{39,j}$ = Numbers of pregnant animals to be retained
- $g_{40,j}$ = Numbers of non-pregnant animals to be retained
- $g_{41,j}$ = Numbers of pregnant animals to cull
- $g_{42,j}$ = Numbers of non-pregnant animals to cull
- $g_{43,j}$ = Summations for output reports
- FLUX FUNCTIONS (Updating State Variables)
- $f_{1,j} = \Delta x_{1,j}$ and $f_{2,j} = \Delta x_{2,j}$

OUTPUT FUNCTION LIST

- $Y_{1,j}$ = herd size and performance reports
- $Y_{2,j}$ = herd composition, by age class totals
- $Y_{3,j}$ = PSV_j = present cull salvage value
- $Y_{4,j} = V_j^P = FVB_j^P / PSV_j$
- $Y_{5,j} = V_j^N = FVB_j^N / PSV_j$
- $Y_{6,j}$ = FVB_j^P for pregnant animals
- $Y_{7,j}$ = FVB_j^N for non-pregnant animals
- $Y_{8,j}$ = sim. vs. hist. statistics for cows
- $Y_{9,j}$ = sim. vs. hist. statistics for heifers
- $Y_{10,j}$ = sim. vs. hist. statistics for culls
- $Y_{11,j}$ = sim. vs. hist. statistics for calves
- $Y_{12,j}$ = cumulative age composition of herd

BEEF COW DEMOGRAPHY MODEL FLOWCHART

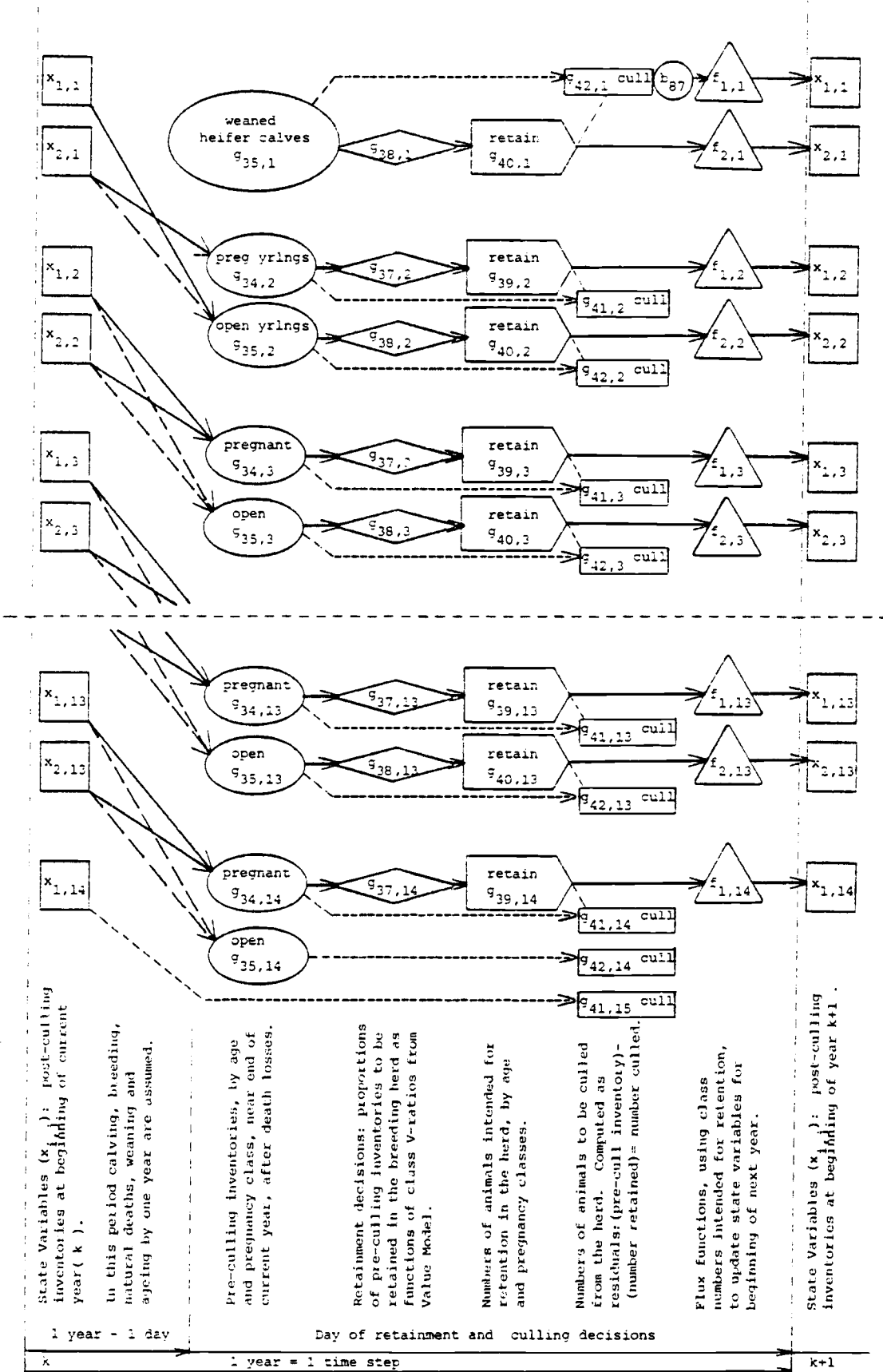

STATE VARIABLE LIST FOR COW VALUE AND DEMOGRAPHY MODEL

State Variable	Initial Value	Units	Description	Used in these functions
x _{1,1}	18.2	100,000 Head	No. of weaned heifers <u>not</u> kept for breeding in the present year but available as yearlings next year	g_{34} g_{43} g_{35} f_1
x _{1,2}	20.7	"	No. of pregnant yearlings kept to calve in the present year as 2 year olds	
x _{1,3}	24.1	"	" " " cows " " " " " " " " 3 " "	
x _{1,4}	19.0	"	" " " " " " " " " " " " 4 " "	
x _{1,5}	15.8	"	" " " " " " " " " " " " 5 " "	
x _{1,6}	14.9	"	" " " " " " " " " " " " 6 " "	
x _{1,7}	11.1	"	" " " " " " " " " " " " 7 " "	
x _{1,8}	10.4	"	" " " " " " " " " " " " 8 " "	
x _{1,9}	10.9	"	" " " " " " " " " " " " 9 " "	
x _{1,10}	8.9	"	" " " " " " " " " " " " 10 " "	
x _{1,11}	7.2	"	" " " " " " " " " " " " 11 " "	
x _{1,12}	2.4	"	" " " " " " " " " " " " 12 " "	
x _{1,13}	1.3	"	" " " " " " " " " " " " 13 " "	
x _{1,14}	1.0	"	" " " " " " " " " " " " 14 " "	
x _{2,1}	35.0	"	No. of weaned heifers kept for breeding (HKB'S) in the present year as 1 year olds	g_{34} g_{35} g_{43} f_2
x _{2,2}	9.2	"	No. of non-pregnant yearlings kept for breeding in the present year as 2 year olds	
x _{2,3}	2.3	"	" " " cows " " " " " " " " 3 " "	
x _{2,4}	1.3	"	" " " " " " " " " " " " 4 " "	
x _{2,5}	.8	"	" " " " " " " " " " " " 5 " "	
x _{2,6}	.7	"	" " " " " " " " " " " " 6 " "	
x _{2,7}	.6	"	" " " " " " " " " " " " 7 " "	
x _{2,8}	.8	"	" " " " " " " " " " " " 8 " "	
x _{2,9}	1.1	"	" " " " " " " " " " " " 9 " "	
x _{2,10}	1.3	"	" " " " " " " " " " " " 10 " "	
x _{2,11}	1.5	"	" " " " " " " " " " " " 11 " "	
x _{2,12}	.7	"	" " " " " " " " " " " " 12 " "	
x _{2,13}	.5	"	" " " " " " " " " " " " 13 " "	

INPUT LIST FOR COW VALUE AND DEMOGRAPHY MODEL

Input	Units		Used in these functions					
z_1	\$/cwt.	weaned calf prices (feeder steer prices)	g_{14}	$g_{12,1}$				
z_2	\$/cwt.	Utility cow prices	g_{14}	$g_{12,2}$				
z_3	Index (78 = 1.0)	fuel, lube, and electricity C.P.I.	g_{16}					
z_4	"	farm machinery C.P.I.	g_{16}					
z_5	"	fed cattle price (for bull charges)	g_{16}					
z_6	"	pasture rental rates	g_{17}	g_{18}	g_{21}			
z_7	"	hay (other hay prices)	g_{17}	g_{18}	g_{21}			
z_8	"	grain (corn price)	g_{17}	g_{18}	g_{21}			
z_9	"	protein supplement (SBOM price)	g_{17}	g_{18}	g_{21}			
z_{10}	"	salt and minerals (salt price)	g_{17}	g_{18}	g_{21}			
z_{11}	"	farm labor wage rate	g_{16}	g_{17}	g_{19}	g_{20}	g_{22}	g_{23}
z_{12}	"	veterinary and medicine	g_{17}	g_{19}	g_{20}	g_{22}	g_{23}	
z_{13}	$\frac{\% \text{ int.}}{100}$	P.C.A. average cost of loans (% interest / 100)	g_{15}	$g_{27,1}$				
z_{14}	years	year counter (beginning in 1950)	$Y_{1,1}$	$g_{44,j}$	$j = 1,4$			
				$g_{4i,2}$	$i = 5,8$			
				$Y_{i,1}$	$i = 8,11$			

MEMORY VARIABLE LIST: STATE VARIABLES IN TIME (k-1)

Memory Variable	Definition	Initial Value	Units	Description	Used in these functions
m _{1,2}	= x _{1,2} (k-1)	159.0	100,000 hd.	Post-culling inventory of pregnant yearlings kept at beginning of previous year	} Y _{1,8} Y _{1,9} Y _{1,10} Y _{1,12} Y _{2,j}
m _{1,3}	= x _{1,3} (k-1)	zero	"	" " " " " cows becoming 3 years old at beginning of previous year	
m _{1,4}	= x _{1,4} (k-1)	"	"	" " " " " " " 4 " " " " " " "	
m _{1,5}	= x _{1,5} (k-1)	"	"	" " " " " " " 5 " " " " " " "	
m _{1,6}	= x _{1,6} (k-1)	"	"	" " " " " " " 6 " " " " " " "	
m _{1,7}	= x _{1,7} (k-1)	"	"	" " " " " " " 7 " " " " " " "	
m _{1,8}	= x _{1,8} (k-1)	"	"	" " " " " " " 8 " " " " " " "	
m _{1,9}	= x _{1,9} (k-1)	"	"	" " " " " " " 9 " " " " " " "	
m _{1,10}	= x _{1,10} (k-1)	"	"	" " " " " " " 10 " " " " " " "	
m _{1,11}	= x _{1,11} (k-1)	"	"	" " " " " " " 11 " " " " " " "	
m _{1,12}	= x _{1,12} (k-1)	"	"	" " " " " " " 12 " " " " " " "	
m _{1,13}	= x _{1,13} (k-1)	"	"	" " " " " " " 13 " " " " " " "	
m _{1,14}	= x _{1,14} (k-1)	"	"	" " " " " " " 14 " " " " " " "	
m _{2,1}	= x _{2,1} (k-1)	zero	"	Post-culling inventory of weaned heifers retained as 1 year olds in previous year	
m _{2,2}	= x _{2,2} (k-1)	"	"	Post-culling inventory of non-pregnant yearlings retained as 2 year olds in previous year	
m _{2,3}	= x _{2,3} (k-1)	"	"	" " " " " " cows " " 3 " " " " " "	
m _{2,4}	= x _{2,4} (k-1)	"	"	" " " " " " " " " 4 " " " " " "	
m _{2,5}	= x _{2,5} (k-1)	"	"	" " " " " " " " " 5 " " " " " "	
m _{2,6}	= x _{2,6} (k-1)	"	"	" " " " " " " " " 6 " " " " " "	
m _{2,7}	= x _{2,7} (k-1)	"	"	" " " " " " " " " 7 " " " " " "	
m _{2,8}	= x _{2,8} (k-1)	"	"	" " " " " " " " " 8 " " " " " "	
m _{2,9}	= x _{2,9} (k-1)	"	"	" " " " " " " " " 9 " " " " " "	
m _{2,10}	= x _{2,10} (k-1)	"	"	" " " " " " " " " 10 " " " " " "	
m _{2,11}	= x _{2,11} (k-1)	"	"	" " " " " " " " " 11 " " " " " "	
m _{2,12}	= x _{2,12} (k-1)	"	"	" " " " " " " " " 12 " " " " " "	
m _{2,13}	= x _{2,13} (k-1)	"	"	" " " " " " " " " 13 " " " " " "	

MEMORY VARIABLE LIST: SUMMATIONS FOR MPAD TEST STATISTICS

Memory Variable	Definition	Initial value	Units	Description	used in these functions
$m_{3,1}$	$= g_{44,1}^{(k-1)}$	Zero	dimensionless	Sum of previous years' proportional absolute deviations of model's estimate of cow numbers from the USDA estimates.	$g_{44,1}$
$m_{3,2}$	$= g_{44,2}^{(k-1)}$	Zero	"	Sum of previous years' proportional absolute deviations of model's estimate of heifer recruitment numbers from the USDA estimates.	$g_{44,2}$
$m_{3,3}$	$= g_{44,3}^{(k-1)}$	Zero	"	sum of the previous years' proportional absolute deviations of model's estimates of cull cow numbers from the USDA estimates.	$g_{44,3}$
$m_{3,4}$	$= g_{44,4}^{(k-1)}$	Zero	"	sum of previous years' proportional absolute deviations of model's estimates of numbers of calves born from estimates derived from historical series.	$g_{44,4}$

NOTE: The above four memory variables are only used to carry forward "sums of proportional absolute deviations" for computation of test statistics. The USDA estimates, to which the estimates of the model are compared, have no influence on the value or demography models.

MEMORY VARIABLE LIST: PAST CATTLE PRICES FOR EXPECTATION MODELS

<u>Memory Variable</u>	<u>Definition</u>	<u>Initial Value</u>	<u>Units</u>	<u>Description</u>	<u>Used in these functions</u>
$m_{4,1}$	= $z_1(k-1)$	23.40	\$/cwt.	Price of feeder steers in previous year.	$g_{12,1}$
$m_{4,2}$	= $z_2(k-1)$	16.65	\$/cwt.	Price of Utility cows in previous year.	$g_{12,2}$

NOTE: The above two memory variables are used in the cattle price expectation functions, $g_{12,1}$ and $g_{12,2}$, to represent a continuation of the most recent one year trend or a weighted average of the previous and present years' prices.

MEMORY VARIABLE LIST; SUMMATIONS FOR TEST STATISTICS ON BEEF COW NUMBERS

Memory Variable	Definition	Initial Value	Units	Description	Used in these functions
$m_{5,1}$	$= g_{43,1}^{(k-1)}$	Zero	million head	Total beef cows (becoming 3 years old and over, and pregnant yearlings) retained at beginning of current year simulated by demography model (S_{k-1}) for computing (P) "predicted changes in cow numbers for comparison with (A) "actual" historical changes.	$g_{45,1}$
$m_{5,2}$	$=$ unassigned	---	----	-----	-----
$m_{5,3}$	$= g_{45,3}^{(k-1)}$	Zero	million head	ΣP	$g_{45,3}$
$m_{5,4}$	$= g_{45,4}^{(k-1)}$	Zero	dimensionless	ΣP^2	$g_{45,4}$
$m_{5,5}$	$= g_{45,5}^{(k-1)}$	Zero	million head	ΣA	$g_{45,5}$
$m_{5,6}$	$= g_{45,6}^{(k-1)}$	Zero	dimensionless	ΣA^2	$g_{45,6}$
$m_{5,7}$	$= g_{45,7}^{(k-1)}$	Zero	dimensionless	ΣPA	$g_{45,7}$
$m_{5,8}$	$= g_{45,8}^{(k-1)}$	Zero	dimensionless	$\Sigma (P-A)^2$	$g_{45,8}$

NOTE:
$$P = \frac{(S_k - S_{k-1})}{S_{k-1}}$$

$$A = \frac{(H_k - H_{k-1})}{H_{k-1}}$$

MEMORY VARIABLE LIST: SUMMATIONS FOR TEST STATISTICS ON HEIFER RECRUITMENT

Memory Variable	Definition	Initial Value	Units	Description	Used in these functions
$m_{6,1}$	$= g_{43,2}^{(k-1)}$	Zero	million head	Total heifers retained for breeding at beginning of current year, simulated by demography model: $\{S_{k-1}\}$ for computing (P) "predicted changes in recruited heifer numbers for comparison with (A) "actual" historical changes.	$g_{46,1}$
$m_{6,2}$	$=$ Unassigned	---	-----	----	-----
$m_{6,3}$	$= g_{46,3}^{(k-1)}$	Zero	million head	$\sum P$	$g_{46,3}$
$m_{6,4}$	$= g_{46,4}^{(k-1)}$	Zero	dimensionless	$\sum P^2$	$g_{46,4}$
$m_{6,5}$	$= g_{46,5}^{(k-1)}$	Zero	million head	$\sum A$	$g_{46,5}$
$m_{6,6}$	$= g_{46,6}^{(k-1)}$	Zero	dimensionless	$\sum A^2$	$g_{46,6}$
$m_{6,7}$	$= g_{46,7}^{(k-1)}$	Zero	dimensionless	$\sum PA$	$g_{46,7}$
$m_{6,8}$	$= g_{46,8}^{(k-1)}$	zero	dimensionless	$\sum (P-A)^2$	$g_{46,8}$

NOTE:

$$P = \frac{(S_k - S_{k-1})}{S_{k-1}}$$

$$A = \frac{H_k - H_{k-1}}{H_{k-1}}$$

MEMORY VARIABLE LIST : SUMMATIONS FOR TEST STATISTICS ON BEEF COW SLAUGHTER NUMBERS

Memory Variable	Definition	Initial Value	Units	Description	Used in these functions
$m_{7,1}$	$= g_{43,3}^{(k-1)}$	Zero	million head	Total beef cows culled (pregnant and non-pregnant, becoming 3 years old and over) at the end of previous year, as simulated by demography model (S_{k-1}) for computing (P) "predicted" changes in cull beef cow numbers for comparison with (A) "actual" historical changes in numbers of beef cows slaughtered.	$g_{47,1}$
$m_{7,2}$	$=$ Unassigned	----	-----	----	-----
$m_{7,3}$	$= g_{47,3}^{(k-1)}$	Zero	million head	ΣP	$g_{47,3}$
$m_{7,4}$	$= g_{47,4}^{(k-1)}$	Zero	dimensionless	ΣP^2	$g_{47,4}$
$m_{7,5}$	$= g_{47,5}^{(k-1)}$	Zero	million head	ΣA	$g_{47,5}$
$m_{7,6}$	$= g_{47,6}^{(k-1)}$	Zero	dimensionless	ΣA^2	$g_{47,6}$
$m_{7,7}$	$= g_{47,7}^{(k-1)}$	Zero	dimensionless	ΣPA	$g_{47,7}$
$m_{7,8}$	$= g_{47,8}^{(k-1)}$	Zero	dimensionless	$\Sigma (P-A)^2$	$g_{47,8}$

NOTE:

$$P = \frac{(S_k - S_{k-1})}{S_{k-1}}$$

$$A = \frac{(H_k - H_{k-1})}{H_{k-1}}$$

MEMORY VARIABLE LIST: SUMMATIONS FOR TEST STATISTICS ON NUMBER OF CALVES BORN TO BEEF COWS

Memory Variable	Definition	Initial Value	Units	Description	Used in these functions
$m_{8,1}$	$= g_{43,6}^{(k-1)}$	Zero	million head	Number of calves born to beef cows and heifers in the previous year as simulated by demography model (S_{k-1}) for computing (P) "predicted" changes in birth numbers for comparison with (A) "actual" historical changes in birth numbers.	$g_{48,1}$
$m_{8,2}$	= Unassigned	----	-----	-----	-----
$m_{8,3}$	$= g_{48,3}^{(k-1)}$	Zero	million head	ΣP	$g_{48,3}$
$m_{8,4}$	$= g_{48,4}^{(k-1)}$	Zero	dimensionless	ΣP^2	$g_{48,4}$
$m_{8,5}$	$= g_{48,5}^{(k-1)}$	Zero	million head	ΣA	$g_{48,5}$
$m_{8,6}$	$= g_{48,6}^{(k-1)}$	Zero	dimensionless	ΣA^2	$g_{48,6}$
$m_{8,7}$	$= g_{48,7}^{(k-1)}$	Zero	dimensionless	ΣPA	$g_{48,7}$
$m_{8,8}$	$= g_{48,8}^{(k-1)}$	Zero	dimensionless	$\Sigma (P-A)^2$	$g_{48,8}$

NOTE: m_9 and m_{10} are unassigned

$$\text{NOTE: } P = \frac{(S_k - S_{k-1})}{S_{k-1}}$$

$$A = \frac{(H_k - H_{k-1})}{H_{k-1}}$$

MEMORY VARIABLE LIST: STATE VARIABLES IN TIME (k-2)

<u>Memory variable</u>	<u>Definition</u>	<u>Initial value</u>	<u>Units</u>	<u>Description</u>	<u>Used in these functions</u>
$m_{11,j}$	$= x_{1,j}^{(k-2)}$	zero	100,000 head	Post-culling inventories of pregnant heifers and cows becoming j years old two years ago. j=2,14	Y _{1,6}
$m_{12,1}$	$= x_{2,1}^{(k-2)}$	zero	100,000 head	Post-culling inventory of weaned heifers kept for breeding (HKB's) two years ago.	Y _{1,6}
$m_{12,j}$	$= x_{2,j}^{(k-2)}$	zero	100,000 head	Post-culling inventory of non-pregnant yearlings and cows becoming j years old two years ago. j = 2,13	Y _{1,6}

INTERMEDIATE FUNCTIONS: BIOLOGICAL PARAMETERS

Description	Units	Used in these functions
<p>$j = 1,14 =$ age at breeding</p> $g_{1,j} = b_1 + b_2(j-b_3) + b_4(j-b_3)^2$ <p>Conception Rate (C_j) as a function of age (j) at breeding</p>	<p>proportion</p> <hr/> <p><u>cows pregnant</u> cows bred</p>	<p>$g_9 \quad g_{34} \quad g_{35} \quad Y_{1,9}$</p>
<p>$j = 1,15 =$ age becoming</p> $g_{2,j} = 1.0 - \left(b_5 + \frac{b_6}{j} + b_7 \cdot j^2 \right)$ <p>Unimpaired health rate (H_j) (complement of the seriously impaired health rate) in the year prior to age j.</p>	<p>proportion</p> <hr/> <p><u>healthy cows</u> now</p> <hr/> <p><u>live cows</u> now</p>	<p>$g_9 \quad g_{37} \quad g_{38}$</p>
<p>$j = 2,15 =$ age becoming</p> $g_{3,j} = b_8 + b_9 \cdot j$ <p>Cow survival rate (S_j) after natural and accidental death in the year prior to age j.</p>	<p>proportion</p> <hr/> <p><u>live cows</u> now</p> <hr/> <p><u>live cows</u> kept one year ago</p>	<p>$g_9 \quad g_{10} \quad g_{34} \quad g_{35}$</p> <p>$g_{41} \quad g_{43,6}$</p>

INTERMEDIATE FUNCTIONS: BIOLOGICAL PARAMETERS (cont.)

Description	Units	Used in these functions
<p>$j = 2, 15 = \text{age becoming}$</p> $g_{4,j} = b_{10} \cdot b_{11} \cdot \left(b_{12} + (b_{13} \cdot j) + \frac{b_{14}}{j} \right) + (1.0 - b_{10}) \cdot b_{15} \cdot \left(b_{16} + (b_{17} \cdot j) + (b_{18} \cdot j^2) + (b_{19} \cdot j^3) \right)$	cwt.	$g_{13} \quad g_{14}$
<p>Cow culling weight (CW_j) at culling time prior to age j.</p>		
<p>$g_5 = b_{10} \cdot b_{11} + (1.0 - b_{10}) \cdot b_{15}$</p> <p>(MA) Maximum aggregate cow body weight (a single value measurement depending on the proportion of early and late maturity breeds.)</p>	cwt.	$g_6 \quad g_7$
<p>$j = 2, 14 = \text{age at calving time}$</p> $g_{6,j} = g_5 \cdot b_{20} \cdot \left(b_{21} + (b_{22} \cdot j) + (b_{23} \cdot j^2) + (b_{24} \cdot j^3) \right)$	cwt.	$g_{25} \quad Y_{1,10}$
<p>(WW_j) Calf weaning weights expected for cows aged (j) years at calving.</p>		

INTERMEDIATE FUNCTIONS: BIOLOGICAL PARAMETERS (cont.)

Description	Units	Used in these functions
$g_7 = g_5 \cdot b_{25}$ Estimated weaning weight for a heifer kept for breeding (HKB) (a single value estimate linked to maximum aggregate cow body weight)	cwt.	g_{13} g_{14}
$j = 2, 14 =$ age at calving	proportion	g_{25} g_{35}
$g_{8,j} = b_{26} + (b_{27} \cdot j) + \left(\frac{b_{28}}{j} \right)$	$\left(\frac{\text{calves weaned}}{\text{pregnant cows}} \right)$	$g_{43,3}$ $Y_{1,10}$
Calf survival rate (CS_j) (calves weaned per pregnant cow kept to calve at age j).		

INTERMEDIATE FUNCTIONS : MANAGEMENT EXPECTATION PARAMETERS

Description	Units	Used in these functions
<p>$j = 1,15 = \text{age becoming}$</p> $g_{9,j} = \begin{cases} 1.0 & , \text{if } j = 1 \\ g_{9,(j-1)} \cdot g_{1,(j-1)} \cdot g_{2,j} \cdot g_{3,j} & , \text{if } j > 1 \end{cases}$	fraction of 1 HKB	g_{10} g_{28}
<p>Expected retainment rate (R_j). The steady state likelihood that an HKB has for being retained in the herd for breeding as a (j) year old cow, subject to natural death, and culling for impaired health and non-pregnancy each year. (That is, for $j = 2,15$; $R_j = R_{(j-1)} \cdot C_{(j-1)} \cdot H_j \cdot S_j$)</p>		
<p>$j = 1,14 = \text{age becoming}$</p> $g_{10,j} = \frac{(g_{9,j} \cdot g_{3,(j+1)}) - g_{9,(j+1)}}{g_{9,j}}$	<p>proportion</p> <p>($\frac{\text{culled next year}}{\text{retained this year}}$)</p>	g_{24} g_{25}
<p>Expected culling rate (EX_j). The steady state likelihood for a cow (becoming j years old) to be culled in the coming year. (that is to survive until the next culling time, then not be retained in the herd:</p>		
$EX_j = \frac{(R_j \cdot S_{(j+1)}) - R_{(j+1)}}{R_j}$		
<p>NOTE: No g_{11} is specified</p>		

INTERMEDIATE FUNCTIONS: EXPECTED PRICES AND EXPECTED SALVAGE VALUES, FSV_j

	Description	Units	Used in these functions
$g_{12,1} = b_{73} \cdot m_{4,1} + (b_{74} \cdot z_1)$	Expected price of feeder steers in future years as a function of their price in the current year (z_1) and in the previous year ($m_{4,1}$).	\$/cwt.	$g_{13,j}$ $g_{25,j}$
$g_{12,2} = b_{75} \cdot m_{4,2} + (b_{76} \cdot z_2)$	Expected price of utility cows in future years as a function of their price in the current year (z_2) and in the previous year ($m_{4,2}$).	\$/cwt.	$g_{13,j}$

NOTE: By altering the b-parameter values in the above functions, the "expected prices" may be defined to represent a continuation of the most recent one year trend or a weighted average of last year's and this year's prices.

$j = 1, 15 =$ age becoming at time of possible salvage sale

$$g_{13,j} = \begin{cases} g_{12,1} \cdot g_7 \cdot b_{39} & , \text{if } j = 1 \\ g_{4,j} \left[g_{12,1} - b_{40} \cdot (g_{12,1} - g_{12,2}) + \frac{b_{40} \cdot (g_{12,1} - g_{12,2})}{j \cdot b_{41}} \right] & , \text{if } j > 1 \end{cases}$$

\$/hd

g_{24} g_{25}

g_{28}

Expected future salvage values (FSV_j), analogous to present salvage values described below, are the product of expected prices and body weights. These values are used in the net annual revenue budgets and in calculations of present values for breeding.

INTERMEDIATE FUNCTIONS: PRESENT SALVAGE VALUE (PSV_j), AND SHORT TERM INTEREST FACTOR

Description	Units	Used in these functions
$j = 1, 15 = \text{age becoming}$ $g_{14,j} = \begin{cases} z_1 \cdot g_7 \cdot b_{39} & , \text{if } j = 1 \\ g_{4,j} \cdot \left[z_1 - b_{40}(z_1 - z_2) + \frac{b_{40}(z_1 - z_2)}{j \cdot b_{41}} \right] & , \text{if } j > 1 \end{cases}$	\$/hd.	$g_{29,1} \quad g_{30}$ $g_{32} \quad y_3$

Present salvage value (PSV_j) estimates. The PSV of an HKB (a weaned heifer kept for breeding), when first retained, is her estimated weight (g₇) times an adjusted feeder steer price (z₁ · b₃₉). The cull sales values of older cows (becoming j=2 to 15 years of age) are the product of their respective body weights (g_{4,j}) and prices. Their respective price estimates are a function of current feeder steer price (z₁) and Utility cow price (z₂), declining hyperbolically with age.

$$g_{15} = \left(1.0 + (b_{42} \cdot z_{13}) + b_{36} \right)^{b_{43}}$$

dimensionless factor

$g_{17} \quad g_{19}$
 $g_{20} \quad g_{22}$
 g_{23}

Factor for inflating operating costs due to short term interest charges. The current P.C.A. average cost of loans (z₁₃, a decimal fraction) is adjusted directly by b₄₂. The exponent b₄₃ represents the fraction of a year for which interest is charged on short term operating costs. The option of using a constant interest rate is allowed with the b₃₆ parameter.

INTERMEDIATE FUNCTIONS: COST CALCULATIONS
Description

	Units	Used in these functions
$g_{16} = (b_{44} \cdot z_{11}) + (b_{45} \cdot z_3) + (b_{46} \cdot z_4) + (b_{47} \cdot z_5)$ <p style="margin-left: 40px;"> \uparrow \uparrow \uparrow \uparrow marketing & fuel, lube & machine & charges hauling costs electric costs building repair </p>	\$/hd./yr	g_{17} g_{19} g_{20} g_{22} g_{23}
Costs common to all budgets.		

$g_{17} = \left[g_{16} + (b_{48} \cdot z_6) + (b_{49} \cdot z_7) + (b_{50} \cdot z_8) + (b_{51} \cdot z_9) + (b_{52} \cdot z_{10}) + (b_{53} \cdot z_{11}) + (b_{54} \cdot z_{12}) \right] g_{15}$ <p style="margin-left: 40px;"> \uparrow \uparrow \uparrow \uparrow \uparrow \uparrow \uparrow \uparrow common pasture Hay Grain & Protein Salt & Labor Veterinary costs rental Cost concentrate supplement mineral costs & medicine cost cost cost cost cost costs \uparrow </p>		g_{25} short term interest factor
Units: \$/hd./yr. Used in these functions:		
Costs peculiar to heifers kept for breeding		

	Units	Used in these functions
$g_{18} = (b_{55} \cdot z_6) + (b_{56} \cdot z_7) + (b_{57} \cdot z_8) + (b_{58} \cdot z_9) + (b_{59} \cdot z_{10})$ <p style="margin-left: 40px;"> \uparrow \uparrow \uparrow \uparrow \uparrow Pasture Hay Grain & Protein Salt & rental Cost concentrate supplement mineral cost cost cost cost </p>	\$/hd./yr	g_{19} g_{20}
Costs common to yearling heifers (pregnant or not)		

INTERMEDIATE FUNCTIONS.: COST CALCULATIONS (cont.)

Description	Units	Used in these functions
$g_{19} = \left[\underset{\substack{\uparrow \\ \text{common} \\ \text{costs}}}{g_{16}} + \underset{\substack{\uparrow \\ \text{labor} \\ \text{costs}}}{g_{18}} + (b_{60} \cdot z_{11}) + (b_{61} \cdot z_{12}) \right] \cdot \underset{\uparrow}{g_{15}}$ <p>Costs peculiar to pregnant yearling heifers.</p>	\$ /hd/yr	g_{25}
$g_{20} = \left[\underset{\downarrow}{g_{16}} + \underset{\downarrow}{g_{18}} + (b_{62} \cdot z_{11}) + (b_{63} \cdot z_{12}) \right] \cdot \underset{\downarrow}{g_{15}}$ <p>Cost peculiar to non-pregnant yearling heifers</p>	\$ /hd/yr	g_{24}
$g_{21} = (b_{64} \cdot z_6) + (b_{65} \cdot z_7) + (b_{66} \cdot z_8) + (b_{67} \cdot z_9) + (b_{68} \cdot z_{10})$ <p style="text-align: center;"> \uparrow \uparrow \uparrow \uparrow \uparrow Pasture Hay Grain & Protein Salt & rental costs concentrate supplement mineral costs costs costs costs </p>	\$ /hd/yr	g_{22} g_{23}
<p>Costs common to mature cows becoming 3 years of age or older, pregnant or not.</p>		
$g_{22} = \left[\underset{\substack{\uparrow \\ \text{common} \\ \text{costs}}}{g_{16}} + \underset{\substack{\uparrow \\ \text{labor} \\ \text{costs}}}{g_{21}} + (b_{69} \cdot z_{11}) + (b_{70} \cdot z_{12}) \right] \cdot \underset{\uparrow}{g_{15}}$ <p>Costs for pregnant mature cows</p>	\$ /hd/yr	g_{25}
$g_{23} = \left[\underset{\downarrow}{g_{16}} + \underset{\downarrow}{g_{21}} + (b_{71} \cdot z_{11}) + (b_{72} \cdot z_{12}) \right] \cdot \underset{\downarrow}{g_{15}}$ <p>Costs for non-pregnant mature cows.</p>	\$ /hd/yr	g_{24}

INTERMEDIATE FUNCTIONS: EXPECTED NET ANNUAL REVENUES, NAR_j^N AND NAR_j^P

	Description	Units	Used in these fcts.
		\$/hd/yr	
$g_{24,j}$	$j = 2,13 = \text{age becoming}$ $\begin{cases} \left[g_{10,2} \cdot g_{13,3} \right] - g_{20} & , \text{if } j = 2 \\ \left[g_{10,j} \cdot g_{13,(j+1)} \right] - g_{23} & , \text{if } j > 2 \end{cases}$		$g_{31,j}$
	<p>Net annual revenue (NAR_j^N) for non-pregnant yearling heifers (becoming 2 years of age if not culled)</p> <p>Net annual revenues (NAR_j^N) for non-pregnant mature cows (becoming j years of age if not culled)</p>		
		\$/hd/yr	
$g_{25,j}$	$j = 1,14 = \text{age becoming}$ $\begin{cases} \left[g_{10,1} \cdot g_{13,2} \right] - g_{17} & , \text{if } j = 1 \\ \left[g_{10,2} \cdot g_{13,3} \right] - g_{19} + (g_{8,2} \cdot g_{6,2} \cdot g_{12,1} \cdot b_{38}) & , \text{if } j = 2 \\ \underbrace{\left[g_{10,j} \cdot g_{13,j+1} \right]}_{\substack{\text{fractional} \\ \text{culling} \\ \text{reserves}}} - g_{22} + \underbrace{(g_{8,j} \cdot g_{6,j} \cdot g_{12,1} \cdot b_{38})}_{\substack{\text{input} \\ \text{costs} \\ \text{calf sales} \\ \text{revenue} \\ (CS_j \cdot WW_j \cdot g_{12,1} \cdot b_{38})}} & , \text{if } j > 2 \end{cases}$		g_{28} g_{31}
	<p>,if j = 1 net annual revenue for HKB's (NAR_1^N)</p> <p>,if j = 2 net annual revenue (NAR_2^P) for pregnant heifers calving as 2 year olds.</p> <p>,if j > 2 net annual revenue (NAR_j^P) for pregnant cows calving as j year olds.</p>		

INTERMEDIATE FUNCTIONS: DISCOUNT RATE AND PVB_{14}^P

Description	Units	Used in these functions
$g_{26,1} = \left(\frac{1.0}{1.0 + (b_{80} \cdot z_{13}) + b_{37}} \right)$	Dimensionless	$g_{28,j}$ $g_{31,j}$
$g_{28,1} = \left[\left(\frac{g_{9,15}}{g_{9,14}} \right) \cdot g_{13,15} + g_{25,14} \right] \cdot g_{26,1}$ <p style="margin-left: 40px;"> ↑ likelihood that a cow becoming 14 years old and retained in the herd will be alive and pregnant next year. </p> <p style="margin-left: 100px;"> ↑ FSV_{15} + includes fractional cull sales revenue of open and unsound cows </p> <p style="margin-left: 100px;"> ↑ NAR_{14}^P includes fractional cull sales revenue of open and unsound cows </p> <p style="margin-left: 100px;"> ↑ discount factor </p>	\$/hd.	$g_{29,1}$ $g_{30,14}$
$PVB_{14}^P =$ The discounted maximum present value expected for a pregnant cow becoming 14 years of age if retained in the herd for one year. It is assumed that all cows becoming 15 years old will be culled, pregnant or not.		
expected final culling revenue		

INTERMEDIATE FUNCTIONS: FV_{14}^P AND FCA_j EXPECTATIONS

	Description	Units	Used in these functions
$g_{29,1} = \frac{g_{28,1}}{g_{13,14}} = FV_{14}^P = \frac{PVB_{14}^P}{FSV_{14}}$	This ratio of future breeding values to future salvage values for cows becoming 14 years old, may be used in limiting the length of the planning horizon for the younger age classes.	dless	$g_{27,2}$
$g_{27,j} = \begin{cases} j=2,14 & \left\{ \begin{array}{l} \min. [15.0, (14.0 + b_{81})] \\ \min. [g_{27,(j-1)}, (16.0 - j + b_{81})] \\ (16.0 - j) \end{array} \right. \end{cases}$	$\begin{cases} , \text{if } j = 2 \text{ and } g_{29,1} \geq b_{82} \\ , \text{if } j > 2 \text{ and } g_{29,(j-1)} \geq b_{82} \\ , \text{if } g_{29,(j-1)} < b_{82} \end{cases}$	years	$g_{27,j}$ $g_{28,j}$

Rules for variable final culling age expectations for cows and heifers becoming 13 years old and younger. These rules assume that (1) no cows shall be retained in the herd as 15 year olds; (2) an arbitrary limit (b_{81}) may be imposed on the length of the planning horizon beyond the first year of the future; and (3) culling shall be planned at an age no older than that at which $FV_j < b_{82}$; nor older than allowed by rules (1) and (2) above.

NOTE: 'dless' indicates a dimensionless constant.

INTERMEDIATE FUNCTIONS: $PVB_{(15-j)}^P$ FOR PREGNANT COWS AND WEANED HKB'S

$j = 2, 14$ (age becoming = 15-j)

Units: \$/head

Used in these functions: g_{29} g_{30} g_{31} Y_6

Description

$$g_{28,j} = \left[\frac{g_{9,(g_{27,j})}}{g_{9,(15-j)}} \right] \cdot g_{13,(g_{27,j})} \cdot g_{26}^{(g_{27,j}-15+j)} + \sum_{i=1}^{g_{27,j}-15+j} \left\{ \frac{g_{9,(14+i-j)}}{g_{9,(15-j)}} \right\} \cdot g_{25,(14+i-j)} \cdot g_{26}^i$$

	↑	↑	↑	↑	↑	↑	↑
	Likelihood that a cow retained as a (15-j) year old will be alive, pregnant and healthy when becoming ($g_{27,j}$) years old.	Expected future cull salvage value for a cow becoming ($g_{27,j}$) years old at culling.	Discount factor to power of length of planning horizon	Likelihood that a cow retained as a (15-j) year old will be retained when becoming (14+i-j) years old.	Expected future net annual revenue for a cow becoming (14+i-j) years old.	Discount factor to the i^{th} power	

$PVB_{(15-j)}^P$ = Present value of final cull sale revenue. + Present value of the sum of future net annual incomes.

INTERMEDIATE FUNCTIONS: FV_j^P and V_j^P

Description	Units	Used in these functions
$j = 2,14$ (age becoming = $15 - j$)	dless	$g_{27,j}$
$g_{29,j} = \frac{g_{28,j}}{g_{13,(15-j)}} = FV_{(15-j)}^P = \frac{PVB_{(15-j)}^P}{FSV_{(15-j)}}$		$j=2,14$

Expected future salvage values ($FSV = g_{13,j}$) are used in computing the present value for breeding (PVB_j^P) and also used here as the denominators of the future expected value ratios (FV_j^P). These value ratios are used only in the final culling age decisions ($FCA_j = g_{27,j}$) to alter the time horizons for the PVB_j calculations. Recall that the sequence of calculation proceeds from the oldest to the youngest. That is, $PVB_{14} \rightarrow FV_{14} \rightarrow FCA_{13} \rightarrow PVB_{13} \rightarrow FV_{13} \rightarrow FCA_{12}$, ect.

$j = 2,14 =$ age becoming	dless	$g_{37,j}$
$g_{30,j} = \frac{g_{28,(15-j)}}{g_{14,j}} = V_j^P = \frac{PVB_j^P}{PSV_j}$		$y_{4,j}$

These ratios of discounted maximum net future revenue (PVB_j^P) to present salvage value (PSV_j) provide the major links between the value model and the demography model. These V-ratios are the criteria on which the retainment rates for the pregnant cow classes are based each year in the demography model.

NOTE: dless indicates a dimensionless constant.

INTERMEDIATE FUNCTIONS; PVB_j^N and V_j^N FOR NON-PREGNANT COWS

Description	Units	Used in these functions
$j = 2, 13 = \text{age becoming}$ $g_{31,j} = g_{28,(15.0-j)} - \left\{ \left(g_{25,j} - g_{24,j} \right) \cdot g_{26,1} \right\} = PVB_j^N$ <div style="display: flex; justify-content: space-around; margin-top: 10px;"> <div style="text-align: center;"> \uparrow (PVB_j^P) </div> <div style="text-align: center;"> \uparrow (NAR_j^P) </div> <div style="text-align: center;"> \uparrow (NAR_j^N) </div> <div style="text-align: center;"> \uparrow discount factor </div> </div>	\$/hd	g_{32} Y_7

This function calculates the discounted maximum present value of future net income expected for non-pregnant cows becoming j years of age, if kept for breeding. This is calculated by adjusting the PVB_j^P for pregnant cows of the same age by the difference in the first years' expected net annual revenues for pregnant and non-pregnant classes. The main difference in each case is due to the likelihood of calf sales revenue accruing to the pregnant cows, but not to the open cows.

$j = 1, 13$ $g_{32,j} = \begin{cases} \frac{g_{28,14}}{g_{14,1}} & , \text{if } j = 1 \\ \frac{g_{31,j}}{g_{14,j}} & , \text{if } j > 1 \end{cases}$	$V_j^n = \frac{PVB_j^N}{PSV_j}$	dimensionless	g_{38} Y_5
---	---------------------------------	---------------	----------------

This function calculates the value ratios (V_j^N) for non-pregnant heifers and cows becoming (j) years of age.

NOTE:

INTERMEDIATE FUNCTIONS: PRE-CULLING INVENTORY OF PREGNANT COWS

leave g_{33} undefined.

	Description	Units	Used in these functions
$j = 2, 14 =$ age becoming		100,000 head	g_{39}
$g_{34,j} =$	$\begin{matrix} \text{(HKB's)} \\ \downarrow \\ x_{2,1} \cdot g_{3,2} \cdot g_{1,1} \end{matrix} \quad , \text{if } j = 2$		
	$\left[\begin{matrix} x_{1,(j-1)} & + & x_{2,(j-1)} \\ \uparrow & & \uparrow \\ \text{pregnant and non-preg-} \\ \text{nant cows (j-1) years} \\ \text{old at breeding.} \end{matrix} \right] \cdot g_{3,j} \cdot g_{1,(j-1)} \quad , \text{if } j > 2$		

This function calculates the number of pregnant animals that would be j years old at calving if not culled now. Here it is assumed that lactating and dry cows have identical survival rates ($g_{3,j}$) and conception rates ($g_{1,j}$), at the same ages.

INTERMEDIATE FUNCTIONS: PRE-CULLING INVENTORIES OF NON-PREGNANT COWS

Description	Units	Used in these functions
$j = 1, 14$	100,000 hd.	g_{40}
$g_{35,j} = \begin{cases} (1/2) \overbrace{\sum_{i=2}^{14} x_{1,i} \cdot g_{8,i}}^{\text{calves weaned}} & , \text{if } j = 1 \\ \left[x_{2,1} \cdot g_{3,2} \cdot (1-g_{1,1}) \right] + x_{1,1} & , \text{if } j = 2 \\ \left[x_{1,(j-1)} + x_{2,(j-1)} \right] \cdot g_{3,j} \cdot (1-g_{1,(j-1)}) & , \text{if } j > 2 \end{cases}$		

This function calculates the number of non-pregnant heifers and cows that would be (j) years old in the next breeding season if not culled now. The proportions of these non-pregnant classes which are retained for breeding in the next season depend on their respective retainment functions. (see g_{38} description below)

NOTE: No g_{36} is specified.

INTERMEDIATE FUNCTIONS: RETAINMENT DECISIONS (linking the calve model with the demography model)

Description	Units	Used in these functions
$j = 2, 14$ $g_{37,j} = b_{88} + \left[\frac{g_{2,j} - b_{88}}{1 + e^{b_{83}(g_{30,j} - b_{84})}} \right]$	dimensionless hd. to keep hd. in pre-culling inventory	$g_{39,j}$
This function determines the proportion of the pre-culling inventory of pregnant cows (becoming j years old) to be retained for calving and rebreeding: depending on V_j^p ($g_{30,j}$) the proportion with unimpaired health, ($g_{2,j}$ = asymptotic max.) and an arbitrary minimum proportion kept.		
(b_{88} = asymptotic min.) (b_{84} = V at inflection.)		

INTERMEDIATE FUNCTION:

RETAINMENT DECISIONS FOR NON-PREGNANT CLASSES

$j = 1, 13$

$$g_{38,j} = \begin{cases} b_{89} + \left[\frac{(b_{94} \cdot g_{2,j}) - b_{89}}{1.0 + e^{b_{92}(g_{32,j} - b_{93})}} \right] & , \text{if } j \leq 2 \\ b_{90} + \left[\frac{(b_{91} \cdot g_{2,j}) - b_{90}}{1.0 + e^{b_{85}(g_{32,j} - b_{86})}} \right] & , \text{if } j > 2 \end{cases}$$

The proportion of weaned and yearling heifers to be kept for breeding; depending on V_j^N ($g_{32,j}$), the proportion with unimpaired health ($g_{2,j}$ = asymptotic max.), and an arbitrary minimum proportion kept (b_{89} = asymptotic min.). b_{94} = max. proportion of healthy weaned heifers that may be kept for breeding. b_{93} = V at inflection.

The proportion of pre-culling inventory of open cows (becoming j years old) to be retained for breeding; depending on V_j^N ($g_{32,j}$), the proportion with unimpaired health ($g_{2,j}$) times an arbitrary factor (b_{91}) (providing an asymptotic max.), and an arbitrary minimum proportion kept (b_{90} = asymptotic min.) b_{86} = V at inflection.

Units
dimensionless

Heifers kept
Heifers on
hand

dimensionless

head to keep
hd. in pre-
culling
inventory

$g_{38,j}$ is used in function $g_{40,j}$

INTERMEDIATE FUNCTIONS: NUMBER OF ANIMALS KEPT FOR BREEDING

Description	Units	Used in these functions
j = 2,14	100,000 hd.	g ₄₁ , g _{43,1}
g _{39,j} = g _{34,j} · g _{37,j}		g _{43,2}
$\left(\begin{array}{l} \text{preculling} \\ \text{inventory of} \\ \text{pregnant cows} \\ \text{becoming } j \text{ years old} \end{array} \right) \times \left(\begin{array}{l} \text{proportion of pregnant cows} \\ \text{kept to calve in the coming} \\ \text{year as } j \text{ year olds.} \end{array} \right) = \left(\begin{array}{l} \text{Number of pregnant cows} \\ \text{kept to calve in the coming} \\ \text{year as } j \text{ year olds.} \end{array} \right)$		f ₁
j = 1,13	100,000 hd	g ₄₂ g _{43,1}
g _{40,j} = g _{35,j} · g _{38,j}		g _{43,2} f ₂
$\left(\begin{array}{l} \text{Pre-culling inventory} \\ \text{of non-pregnant heifers} \\ \text{and cows becoming } j \\ \text{years old.} \end{array} \right) \times \left(\begin{array}{l} \text{Proportion of non-pregnant} \\ \text{cows kept for breeding in} \\ \text{the coming year as } j \text{ year} \\ \text{olds.} \end{array} \right) = \left(\begin{array}{l} \text{Number of non-pregnant} \\ \text{cows kept for breeding in} \\ \text{the coming year as } j \text{ year} \\ \text{olds.} \end{array} \right)$		

INTERMEDIATE FUNCTIONS: NUMBERS OF ANIMALS TO BE CULLED

	Description	Units	Used in these functions
$j = 2, 15 =$ age becoming	number of pregnant animals in preculling inventory (becoming j years old) <u>minus</u> number of pregnant cows kept for calving as j year olds in the coming year gives the number of pregnant cows culled before reaching j years of age.	100,000 head	$g_{43,3}$
$g_{41,j} =$	$g_{34,j} - g_{39,j}$,if $j < 15$		
	$x_{1,14} \cdot g_{3,15}$,if $j = 15$	Number of cows calving as 14 year olds this year <u>times</u> the survival rate for 14 year old cows gives the number of cows which compromise the class of animals becoming 15 years old. The model culls all of these with the arbitrary final culling age rule.	
$j = 1, 14 =$ age becoming		100,000 hd.	
$g_{42,j} =$	$g_{35,j} - g_{40,j}$,if $j < 14$	Number of non-pregnant heifers and cows becoming j years old in pre-culling inventories <u>minus</u> Number of non-pregnant cows to be kept for breeding as j year olds, gives the numbers culled.	$g_{43,3}$ f_1
	$g_{35,14}$,if $j = 14$	Number of non-pregnant cows becoming 14 years old in the pre-culling inventory. All are culled here by the arbitrary rule that non-pregnant $13\frac{1}{2}$ year olds should not be kept another year.	

INTERMEDIATE FUNCTIONS : SUBTOTALS FOR TEST STATISTICS AND OUTPUT REPORTS

Description	Units	used in these functions
$g_{43,1} = \left[(b_{98} \cdot g_{39,2}) + \left(\sum_{i=3}^{14} g_{39,i} \right) + \left(\sum_{i=3}^{13} g_{40,i} \right) \right] (0.1)$ <p>Total pregnant yearling heifers + pregnant cows + non-pregnant cows</p>	million head	$g_{44,1}$ $m_{5,1}$ $g_{45,1}$ $Y_{1,2}$ $Y_{1,13}$
<p>Number retained in herd after this year's culling. This number should simulate the USDA estimates of beef cow numbers in the January 1 inventory in the year ($z_{14}+1$).</p>		
$g_{43,2} = \left[(b_{95} \cdot g_{39,2}) + (b_{96} \cdot g_{40,1}) + (b_{97} \cdot g_{40,2}) \right] (0.1)$ <p>Total pregnant yearling heifers + pregnant heifers breeding + weaned heifers kept for breeding + non-pregnant yearling heifers</p>	million head	$g_{44,2}$ $g_{46,1}$ $Y_{1,13}$ $m_{6,1}$ $Y_{1,14}$
<p>Reported as beef heifers recruited into the breeding herd. The respective weighting factors b_{95}, b_{96}, and b_{97} allow the inclusion of more or less of the numbers simulated in these categories in the total to be compared with the USDA estimates of "heifers for replacement" on January 1 in year ($z_{14}+1$)</p>		
$g_{43,3} = \left[\left(\sum_{i=3}^{15} g_{41,i} \right) + \left(\sum_{i=3}^{14} g_{42,i} \right) \right] (0.1)$	million head	$g_{44,3}$ $g_{47,1}$ $Y_{1,4}$ $m_{7,1}$ $Y_{1,11}$ $Y_{1,15}$
<p>Total cows (pregnant + non-pregnant) culled during the current simulated year. This number should simulate the USDA estimates of beef cow slaughter numbers for the year z_{14}.</p>		

INTERMEDIATE FUNCTIONS: SUBTOTALS FOR TEST STATISTICS AND OUTPUT REPORTS

	Description	Units	Used in these functions
$g_{43,4} = \sum_{i=2}^{14} (x_{1,i} \cdot g_{8,i})$	$\begin{array}{cc} 14 & \\ \uparrow & \uparrow \\ \sum_{i=2}^{14} (x_{1,i} \cdot g_{8,i}) & \\ \text{pregnant calf} & \\ \text{cow survival} & \\ \text{numbers rates} & \end{array}$	100,000 hd.	$Y_{1,5} \quad Y_{1,6}$ $Y_{1,7} \quad Y_{1,8}$ $Y_{1,10} \quad Y_{1,14}$

This function determines the number of calves weaned in the current year, Z_{14} .

$g_{43,5} = \left(\sum_{i=2}^{14} x_{1,i} \right) + \left(\sum_{i=2}^{13} x_{2,i} \right)$	100,000 hd.	$Y_{1,7} \quad Y_{1,9}$ $Y_{1,12}$
<p>Total pregnant and non-pregnant cows and heifers (becoming 2 years old and older) on inventory at beginning of current year.</p>		

$g_{43,6} = \left\{ \sum_{i=2}^{14} (x_{1,i} \cdot g_{3,(i+1)}) \right\} (0.1)$	million head	$g_{48,1}$ $Y_{1,13} \quad Y_{1,14}$ $m_{8,1}$
<p>numbers \times cow survival rates = Estimated number of calves born to beef cows in the current year (total). This number should simulate estimates of calves born to beef cows, derived from USDA data on total calves born and dairy cow numbers.</p>		

INTERMEDIATE FUNCTIONS: TEST STATISTICS (Sum accumulations for MPAD's)

Description	Units	Used in these functions
$g_{44,1} = m_{3,1} + \left \frac{g_{43,1} - b_{(z_{14}-1849)}}{b_{(z_{14}-1849)}} \right $ <p>Previous sum + This years proportional absolute deviation of the model's estimates of cow numbers from the USDA estimates. (b₁₀₁ → b₁₂₉)</p>	dimensionless	m _{3,1} Y _{8,2}
$g_{44,2} = m_{3,2} + \left \frac{g_{43,2} - b_{(z_{14}-1819)}}{b_{(z_{14}-1819)}} \right $ <p>Previous sum + This years proportional absolute deviation of the model's estimates of heifer recruitment numbers from the USDA estimates (b₁₃₁ → b₁₅₉)</p>	dimensionless	m _{3,2} Y _{8,2}
$g_{44,3} = m_{3,3} + \left \frac{g_{43,2} - b_{(z_{14}-1790)}}{b_{(z_{14}-1790)}} \right $ <p>Previous sum + This years proportional absolute deviation of the model's estimates of cull cow numbers from the USDA estimates (b₁₆₀ → b₁₈₈)</p>	dimensionless	m _{3,3} Y _{9,2}
$g_{44,4} = m_{3,4} + \left \frac{g_{43,6} - b_{(z_{14}-1760)}}{b_{(z_{14}-1760)}} \right $ <p>Previous sum + this years proportional absolute deviation of the model's estimates of number of calves born to beef cows from those derived from USDA statistics. (b₁₉₀ → b₂₁₈)</p>	dimensionless	m _{3,4} Y _{11,2}

INTERMEDIATE FUNCTIONS: TRANSFORMATIONS AND SUMMATIONS FOR TEST STATISTICS ON BEEF COW NUMBERS

Note: when $z_{14} = 1950$, $g_{45,1}$ through $g_{45,8}$ are not to be computed.

	Description	Used in these functions
$g_{45,1} = (g_{43,1} - m_{5,1}) / m_{5,1}$	$= P = (S_k - S_{k-1}) / S_{k-1}$ Proportional change in simulated cow numbers	$g_{45,j}$ $j=3,4,7$ & 8
$g_{45,2} = (b_{(z_{14}-1849)} - b_{(z_{14}-1850)}) / b_{(z_{14}-1850)}$	$= A = (H_k - H_{k-1}) / H_{k-1}$ Proportional change in historical beef cow numbers	$g_{45,j}$ $j=5,6,7$ & 8
$g_{45,3} = m_{5,3} + g_{45,1}$	$= \Sigma P$	$g_{45,j}$ $j=9,11$ & 13 $m_{5,3}$
$g_{45,4} = m_{5,4} + (g_{45,1})^2$	$= \Sigma P^2$	$g_{45,9}$ $m_{5,4}$
$g_{45,5} = m_{5,5} + g_{45,2}$	$= \Sigma A$	$g_{45,j}$ $j=10,11$ & 13 $m_{5,5}$
$g_{45,6} = m_{5,6} + (g_{45,2})^2$	$= \Sigma A^2$	$g_{45,j}$ $j=10$ & 12 $m_{5,6}$
$g_{45,7} = m_{5,7} + (g_{45,1} g_{45,2})$	$= \Sigma PA$	$g_{45,11}$ $m_{5,7}$
$g_{45,8} = m_{5,8} + (g_{45,1} - g_{45,2})^2$	$= \Sigma (P-A)^2$	$g_{45,j}$ $j=12,13,14$ & 15 $m_{5,8}$

INTERMEDIATE FUNCTIONS: STANDARD STATISTICS AND THEIL'S MEASURES OF INEQUALITY FOR COW NUMBERS

($b_{100}=28=n$) Note: $g_{45,9}$ through $g_{45,10}$ are computed only when $z_{14}=1978$, otherwise set at zero.

	Description	Used in these functions
$g_{45,9} = \left(\sqrt{(b_{100} g_{45,4}) - (g_{45,3})^2} \right) / b_{100}$	$= S_P = \frac{1}{n} \sqrt{n \Sigma P^2 - (\Sigma P)^2}$ Standard deviation of simulated changes	$g_{45,j}$ $j=11,14 \text{ \& } 15$
$g_{45,10} = \left(\sqrt{(b_{100} g_{45,6}) - (g_{45,5})^2} \right) / b_{100}$	$= S_A = \frac{1}{n} \sqrt{n \Sigma A^2 - (\Sigma A)^2}$ Standard deviation of historical changes	$g_{45,j}$ $j=11,14 \text{ \& } 15$
$g_{45,11} = \frac{(b_{100} g_{45,7}) - (g_{45,3} g_{45,5})}{(b_{100})^2 g_{45,9} g_{45,10}}$	$= r = \left(n \Sigma PA - (\Sigma P)(\Sigma A) \right) / n^2 (S_P S_A)$ Correlation coefficient	$Y_{8,3}$ $g_{45,15}$
$g_{45,12} = \sqrt{g_{45,8} / g_{45,6}}$	$= \text{Theil's } U = \sqrt{\Sigma (P-A)^2 / \Sigma A^2}$	$Y_{8,4}$
$g_{45,13} = \frac{(g_{45,3} - g_{45,5})^2}{(b_{100} g_{45,8})}$	$= \text{Theil's } U^m = \left(\frac{\Sigma P}{n} - \frac{\Sigma A}{n} \right)^2 / \frac{1}{n} \Sigma (P-A)^2$ Proportion of inequality due to mean bias	$Y_{8,5}$
$g_{45,14} = b_{100} (g_{45,9} - g_{45,10})^2 / g_{45,8}$	$= \text{Theil's } U^S = (S_P - S_A)^2 / \frac{1}{n} \Sigma (P-A)^2$ Proportion of inequality due to unequal variance	$Y_{8,6}$
$g_{45,15} = \left(2 b_{100} (1 - g_{45,11}) (g_{45,9} g_{45,10}) \right) / g_{45,8}$	$= 2 (1 - r) (S_P S_A) / \frac{1}{n} \Sigma (P-A)^2$ Theil's $U^C =$ Proportion of inequality due to imperfect covariation	$Y_{8,7}$

INTERMEDIATE FUNCTIONS: TRANSFORMATIONS AND SUMMATIONS FOR TEST STATISTICS ON HEIFER NUMBERS RECRUITED

NOTE: when $z_{14} = 1950$, $g_{46,1}$ through $g_{46,8}$ are not to be computed.

	Description	Used in these functions
$g_{46,1} = (g_{43,2}^{-m_{6,1}}) / m_{6,1}$	$= P = (S_k - S_{k-1}) / S_{k-1}$ Proportional changes in simulated numbers of heifers recruited	$g_{46,j}$ $j=3,4,7\&8$
$g_{46,2} = \left(b_{(z_{14}-1819)}^{-b_{(z_{14}-1820)}} \right) / b_{(z_{14}-1820)}$	$= A = (H_k - H_{k-1}) / H_{k-1}$ Proportional changes in historical numbers of heifers recruited	$g_{46,j}$ $j=5,6,7\&8$
$g_{46,3} = m_{6,3} + g_{46,1}$	$= \Sigma P$	$g_{46,j}$ $j=9,11\&13$ $m_{6,3}$
$g_{46,4} = m_{6,4} + (g_{46,1})^2$	$= \Sigma P^2$	$g_{46,9}$ $m_{6,4}$
$g_{46,5} = m_{6,5} + g_{46,2}$	$= \Sigma A$	$g_{46,j}$ $j=10,11\&13$ $m_{6,5}$
$g_{46,6} = m_{6,6} + (g_{46,2})^2$	$= \Sigma A^2$	$g_{46,j}$ $j=10 \& 12$ $m_{6,6}$
$g_{46,7} = m_{6,7} + [g_{46,1} g_{46,2}]$	$= \Sigma PA$	$g_{46,11}$ $m_{6,7}$
$g_{46,8} = m_{6,8} + [g_{46,1}^{-g_{46,2}}]^2$	$= \Sigma (P-A)^2$	$g_{46,j}$ $j=12,13,14$ $\&15$ $m_{6,8}$

INTERMEDIATE FUNCTIONS: STANDARD STATISTICS AND THEIL'S MEASURES OF INEQUALITY FOR HEIFERS RECRUITED

NOTE $g_{46,9}$ through $g_{46,15}$ are to be computed only when $z_{14} = 1978$, otherwise set at zero

$(b_{100} = 28 = n)$

	Description		Used in these functions
$g_{46,9} = \sqrt{(b_{100} g_{46,4}) - (g_{46,3})^2} / b_{100}$		$= S_P$	$g_{46,j}$ $j=11,14$ & 15
$g_{46,10} = \sqrt{(b_{100} g_{46,6}) - (g_{46,5})^2} / b_{100}$		$= S_A$	$g_{46,j}$ $j=11,14$ & 15
$g_{46,11} = \left((b_{100} g_{46,7}) - (g_{46,3} g_{46,5}) \right) / (b_{100})^2 g_{46,9} g_{46,10}$		$= r$	$g_{46,15}$ $Y_{9,3}$
$g_{46,12} = \sqrt{g_{46,8} / g_{46,6}}$		$= \text{Theil's } U$	$Y_{9,4}$
$g_{46,13} = (g_{46,3} - g_{46,5})^2 / (b_{100} g_{46,8})$		$= \text{Theil's } U^m$	$Y_{9,5}$
$g_{46,14} = (b_{100}) (g_{46,9} - g_{46,10})^2 / g_{46,8}$		$= \text{Theil's } U^S$	$Y_{9,6}$
$g_{46,15} = \left[2 b_{100} (1 - g_{46,11}) g_{46,9} g_{46,10} \right] / g_{46,8}$		$= \text{Theil's } U^C$	$Y_{9,7}$

INTERMEDIATE FUNCTIONS: TRANSFORMATIONS AND SUMMATIONS FOR TEST STATISTICS
ON CULL BEEF COW SLAUGHTER NUMBERS

NOTE: when $z_{14} = 1950$, $g_{47,1}$ through $g_{47,8}$ are not to be computed.

Description	Used in these functions
$g_{47,1} = (g_{43,3}^{-m_{7,1}}) / m_{7,1} \qquad = P = (S_k - S_{k-1}) / S_{k-1}$ <p style="text-align: center;">Proportional change is simulated numbers of beef cows culled.</p>	$g_{47,j} \quad j=3,4,7&8$
$g_{47,2} = \left[(z_{14} - 1790)^{-b} (z_{14} - 1791) \right] / (z_{14} - 1791)^b \qquad = A = (H_k - H_{k-1}) / H_{k-1}$ <p style="text-align: center;">Proportional change in historical numbers of beef cows slaughtered.</p>	$g_{47,j} \quad j=5,6,7&8$
$g_{47,3} = m_{7,3} + g_{47,1} \qquad = \Sigma P$	$g_{47,j} \quad j=9,11,13$ $m_{7,3}$
$g_{47,4} = m_{7,4} + (g_{47,1})^2 \qquad = \Sigma P^2$	$g_{47,9} \quad m_{7,4}$
$g_{47,5} = m_{7,5} + g_{47,2} \qquad = \Sigma A$	$g_{47,j} \quad j=10,11&13$ $m_{7,5}$
$g_{47,6} = m_{7,6} + (g_{47,2})^2 \qquad = \Sigma A^2$	$g_{47,j} \quad j=10 \text{ \& } 12$ $m_{7,6}$
$g_{47,7} = m_{7,7} + [g_{47,1} g_{47,2}] \qquad = \Sigma PA$	$g_{47,11} \quad m_{7,7}$
$g_{47,8} = m_{7,8} + [g_{47,1} - g_{47,2}]^2 \qquad = \Sigma (P-A)^2$	$g_{47,j} \quad j=12,13,14$ $\text{ \& } 15$ $m_{7,8}$

INTERMEDIATE FUNCTIONS: STANDARD STATISTICS AND THEIL'S MEASURES OF INEQUALITY FOR CULL BEEF COW NUMBERS
FOR SLAUGHTER

($b_{100} = 28 = n$) NOTE: $g_{47,9}$ through $g_{47,15}$ are computed only when $z_{14} = 1978$, otherwise, set at zero

	Description		Used in these functions
$g_{47,9} = \sqrt{(b_{100} g_{47,4}) - (g_{47,3})^2} / b_{100}$		= S_P	$g_{47,j}$ $j=11,14,$ & 15
$g_{47,10} = \sqrt{(b_{100} g_{47,6}) - (g_{47,5})^2} / b_{100}$		= S_A	$g_{47,j}$ $j=11,14$ & 15
$g_{47,11} = \left((b_{100} g_{47,7}) - (g_{47,3} g_{47,5}) \right) / (b_{100})^2 g_{47,9} g_{47,10}$		= r	$g_{47,15}$ $Y_{10,3}$
$g_{47,12} = \sqrt{g_{47,8} / g_{47,6}}$		= Theil's U	$Y_{10,4}$
$g_{47,13} = (g_{47,3} - g_{47,5})^2 / (b_{100} g_{47,8})$		= Theil's U^m	$Y_{10,5}$
$g_{47,14} = b_{100} (g_{47,9} - g_{47,10})^2 / g_{47,8}$		= Theil's U^s	$Y_{10,6}$
$g_{47,15} = \left(2 b_{100} (1 - g_{47,11}) g_{47,9} g_{47,10} \right) / g_{47,8}$		= Theil's U^c	$Y_{10,7}$

INTERMEDIATE FUNCTIONS: TRANSFORMATIONS AND SUMMATIONS FOR TEST STATISTICS ON NUMBERS OF CALVES BORN
TO BEEF COWS

NOTE: when $z_{14}=1950$, $g_{48,1}$ through $g_{48,8}$ are not computed

	Description	Used in these functions
$g_{48,1} = (g_{43,6}^{-m_{8,1}}) / m_{8,1}$	$= P = (S_k - S_{k-1}) / S_{k-1}$ Proportional change in simulated numbers of calves born to beef cows	$g_{48,j}$ $j=3,4,7\&8$
$g_{48,2} = \left[b(z_{14}-1760)^{-b(z_{14}-1761)} \right] / b(z_{14}-1761)$	$= A = (H_k - H_{k-1}) / H_{k-1}$ Proportional change in historical numbers of calves born to beef cows	$g_{48,j}$ $j=5,6,7\&8$
$g_{48,3} = m_{8,3} + g_{48,1}$	$= \Sigma P$	$g_{48,j}$ $j=9,11$ & 13 $m_{8,3}$
$g_{48,4} = m_{8,4} + (g_{48,1})^2$	$= \Sigma P^2$	$g_{48,9}$ $m_{8,4}$
$g_{48,5} = m_{8,5} + g_{48,2}$	$= \Sigma A$	$g_{48,j}$ $j=10,11$ & 13 $m_{8,5}$
$g_{48,6} = m_{8,6} + (g_{48,2})^2$	$= \Sigma A^2$	$g_{48,j}$ $j=10$ & 12 $m_{8,6}$
$g_{48,7} = m_{8,7} + [g_{48,1} g_{48,2}]$	ΣPA	$g_{48,11}$ $m_{8,7}$
$g_{48,8} = m_{8,8} + [g_{48,1} - g_{48,2}]^2$	$\Sigma (P-A)^2$	$g_{48,j}$ $j=12,13,$ 14 & 15 $m_{8,8}$

INTERMEDIATE FUNCTIONS: STANDARD STATISTICS AND THEIL'S MEASURES OF INEQUALITY FOR NUMBERS OF CALVES
BORN TO BEEF COWS

NOTE: $g_{48,9}$ through $g_{48,15}$ are computed only when $z_{14} = 1978$, otherwise set at zero. ($b_{100} = 28 = n$)
Used in these functions

	Description		
$g_{48,9} = \sqrt{(b_{100} g_{48,4}) - (g_{48,3})^2} / b_{100}$		= S_P	$g_{48,j}$ $j=11,14$ & 15
$g_{48,10} = \sqrt{(b_{100} g_{48,6}) - (g_{48,5})^2} / b_{100}$		= S_A	$g_{48,j}$ $j=11,14$ & 15
$g_{48,11} = \left((b_{100} g_{48,7}) - (g_{48,3} g_{48,5})^2 \right) / (b_{100})^2 g_{48,9} g_{48,10}$		= r	$g_{48,15}$ $Y_{11,3}$
$g_{48,12} = \sqrt{g_{48,8} / g_{48,6}}$		= Theil's U	$Y_{11,4}$
$g_{48,13} = (g_{48,3} - g_{48,5})^2 / b_{100} g_{48,8}$		= Theil's U^m	$Y_{11,5}$
$g_{48,14} = b_{100} (g_{48,9} - g_{48,10})^2 / g_{48,8}$		= Theil's U^s	$Y_{11,6}$
$g_{48,15} = \left(2 b_{100} (1 - g_{48,11}) g_{48,9} g_{48,10} \right) / g_{48,8}$		= Theil's U^c	$Y_{11,7}$

FLUX FUNCTIONS FOR POST-CULLING INVENTORIES: UPDATING THE STATE VARIABLES $x_{1,j}$ and $x_{2,j}$

	Description	Units
$f_{1,j} = \begin{cases} (g_{42,1} b_{87}) - x_{1,1} & , \text{if } j = 1 \\ g_{39,j} - x_{1,j} & , \text{if } j > 1 \end{cases}$	Fraction of these which may be candidates next year for recruitment to the breeding herd as yearling heifers.	number of animals in the special class of non-pregnant heifers ($x_{1,1}$) which are not selected for breeding as 1 year olds, but are potentially available to join the selection pool of non-pregnant yearling heifers becoming 2 year olds, next year.
		$\left[\begin{matrix} 100,000 \\ \text{head} \end{matrix} \right]$

\uparrow
 Number of pregnant animals to be kept for calving in the coming year as j year olds. = Post-culling inventories of pregnant animals in breeding herd, carried into year $z_{14}+1$

$f_{2,j} = g_{40,j} - x_{2,j}$	number of non-pregnant animals to be kept for breeding in the coming year as j year olds	Post-culling inventories of non-pregnant animals in breeding herd, carried into year $z_{14}+1$	$\left[\begin{matrix} 100,000 \\ \text{head} \end{matrix} \right]$
	\downarrow		

OUTPUT FUNCTIONS

	Description	Units
$Y_{1,1} = z_{14}$	Current year (1950-1978)	years
$Y_{1,2} = g_{43,1}$	Number of cows, (pregnant and non-pregnant, becoming 3 years old and over) retained in the herd after this years culling. These cows will comprise the January 1 inventory in year $z_{14}+1$ comparable to USDA records. (See Y_8 for test statistics.) Also includes pregnant yearlings.	million head
$Y_{1,3} = g_{43,2}$	Number of weaned heifers and pregnant and non-pregnant yearling heifers simulated for comparison with USDA records. These heifers comprise the Jan. 1 inventory of "heifers for replacement" in year $z_{14} + 1$, comparable to USDA records. (See Y_9 for Test statistics)	million head
$Y_{1,4} = g_{43,3}$	Number of cows, (pregnant and non-pregnant, becoming 3 years old and over) culled from the herd in the current year (z_{14}). This number of culls is comparable to USDA records of beef cow slaughter numbers. (See Y_{10} for test statistics.)	million head

OUTPUT FUNCTIONS

	Description	Units
$Y_{1,5} = (g_{43,4}) (0.1)$	Number of calves weaned in the current year	million head
$Y_{1,6} = \frac{g_{43,4}}{\left(\sum_{i=2}^{14} m_{11,i} + \sum_{i=1}^{13} m_{12,i} \right)}$	Number of calves weaned in the current year per cow and heifer exposed for breeding in the previous year.	$\frac{\text{calves}}{\text{cows}}$
$Y_{1,7} = \frac{g_{43,4}}{g_{43,5}}$	Number of calves weaned in current year, per cow and heifer (becoming 2 years old and over, pregnant and non-pregnant) on inventory at beginning of year.	$\frac{\text{calves}}{\text{cows}}$
$Y_{1,8} = \frac{g_{43,4}}{\left(\sum_{i=2}^{14} m_{1,i} \right)}$	Number of calves weaned in current year, per pregnant cow and heifer on inventory at beginning of current year.	$\frac{\text{calves}}{\text{cow}}$

OUTPUT FUNCTIONS

	Description	Units
$Y_{1,9} = \frac{\sum_{i=2}^{14} (m_{1,i} \cdot g_{1,i}) + \sum_{i=1}^{13} (m_{2,i} \cdot g_{1,i})}{g_{43,5} + m_{2,1}}$	Average conception rate of all heifers and cows exposed for breeding in the current year.	proportion
$Y_{1,10} = \left\{ \frac{\sum_{i=2}^{14} (m_{1,i} \cdot g_{6,i} \cdot g_{8,i})}{g_{43,4}} \right\} (100)$	Average calf weaning weight in current year	lbs./hd.
$Y_{1,11} = \left\{ \frac{\sum_{i=3}^{15} (g_{41,i} \cdot g_{4,i}) + \left(\sum_{i=3}^{14} (g_{42,i} \cdot g_{4,i}) \right)}{g_{43,3}} \right\} (10.0)$	Average culling weight of cows culled in current year (that would have become 3 or more years old if not culled.)	lbs./hd.
$Y_{1,12} = \frac{\sum_{i=2}^{14} (i \cdot m_{1,i}) + \sum_{i=1}^{13} (i \cdot m_{2,i})}{(g_{43,5} + m_{2,1})}$	Average age of breeding herd at breeding time in current year. Includes weaned heifers kept for breeding at one year of age.	years of age

OUTPUT FUNCTIONS

	Description	Units
$Y_{1,13} = g_{43,6}$	<p>Number of calves born to beef cows in the current year.</p> <p>This number of calves is comparable to the historical series derived from USDA data on total calf births and dairy cow numbers. This comparison is reported in the output function Y_{11} (Test statistics)</p>	million head
$Y_{1,14} = \left(\frac{g_{43,4}}{g_{43,6}} \right) (0.1)$	<p>Number of calves weaned per calf born to beef cows in the current year.</p>	<p>proportion</p> <p><u>calves weaned</u></p> <p><u>calves born</u></p>

OUTPUT FUNCTIONS

	Description	Units
$j = 1, 14$ $Y_{2,j} = \begin{cases} m_{2,1} & , \text{if } j = 1 \\ m_{2,j} + m_{1,j} & , \text{if } 1 < j < 14 \\ m_{1,14} & , \text{if } j = 14 \end{cases}$	<p>Number of animals becoming (j) years old, in post-culling inventories at beginning of current year. These are totals of pregnant and non-pregnant classes by age groups (for age distribution plots). Used in $Y_{12,j}$</p>	100,000 head
$j = 1, 15 = \text{age becoming}$ $Y_{3,j} = g_{14,j} = PSV_j$	<p>= Present cull salvage value for animals becoming j years old.</p>	\$/head
$j = 2, 14 = \text{age becoming}$ $Y_{4,j} = g_{30,j} = v_j^P = \frac{PVB_j^P}{PSV_j}$	<p>= V-ratios for pregnant classes</p>	dimensionless
$j = 1, 13 = \text{age becoming}$ $Y_{5,j} = g_{32,j} = v_j^N = \frac{PVB_j^N}{PSV_j}$	<p>= V-ratios for non-pregnant classes</p>	dimensionless

OUTPUT FUNCTIONS

Description	Units
<p>$j = 2, 14 =$ age becoming</p> <p>$Y_{6,j} = g_{28, (15 - j)} = PVB_j^P$</p> <p>Present value for breeding for pregnant animals becoming (j) years old. This is the discounted max present value of future net income expected for pregnant heifers or cows becoming (j) years of age if kept for breeding.</p>	\$/head
<p>$j = 1, 13 =$ age becoming</p> <p>$Y_{7,j} = \left\{ \begin{array}{ll} g_{28,14} & , \text{if } j = 1 \\ g_{31,j} & , \text{if } j > 1 \end{array} \right\} = PVB_j^N$</p> <p>Present value for breeding for non-pregnant animals becoming (j) years old.</p>	\$/head

OUTPUT FUNCTIONS; TEST STATISTICS COMPARING SIMULATED AND HISTORICAL BEEF COW NUMBERS:
 January 1 inventory, year $z_{14} + 1$

	Description	Units
$Y_{8,1} = \frac{g_{43,1}}{b(z_{14} - 1849)}$	Simulated number of beef cows as a proportion of the historical number $\left(\frac{S_k}{H_k}\right)$ for each year of the run.	dimensionless
NOTE: $Y_{8,2}$ through $Y_{8,7}$ to computed only when $z_{14} = 1978$, otherwise, set to zero		
$Y_{8,2} = \frac{g_{44,1}}{b_{99}}$	MPAD = mean proportional absolute deviation of simulated (S) cow numbers from historical (H) cow numbers. $= \left(\frac{\sum_{i=1951}^{1979} \left \frac{(S_i - H_i)}{H_i} \right }{29 \text{ years}} \right)$	dimensionless
$Y_{8,3} = g_{45,11}$	r = correlation coefficient between simulated and historical series of beef cow number changes.	dimensionless
$Y_{8,4} = g_{45,12}$	Theil's U = Inequality coefficient for comparing simulated changes with historical changes in beef cow numbers.	dimensionless

OUTPUT FUNCTIONS: BEEF COW NUMBER STATISTICS (cont.)

$Y_{8,5} = g_{45,13}$	Theil's U^m = proportion of inequality due to mean bias.	dimensionless
$Y_{8,6} = g_{45,14}$	Theil's U^s = proportion of inequality due to unequal variance.	dimensionless
$Y_{8,7} = g_{45,15}$	Theil's U^c = proportion of inequality due to imperfect covariation. NOTE: $U^m + U^s + U^c = 1.0$	dimensionless
$Y_{8,8} = g_{43,1}$	} Simulated January 1 inventory of beef cows for year $z_{14}+1$ for plots	million head
$Y_{8,9} = b_{(z_{14}-1849)}$		} Historical January 1 inventory of beef cows for year $z_{14}+1$

OUTPUT FUNCTIONS: TEST STATISTICS COMPARING SIMULATED AND HISTORICAL HEIFER NUMBERS RECRUITED
 January 1 inventory, for year $z_{14}+1$

	Description	Units
$Y_{9,1} = \frac{g_{43,2}}{b(z_{14} - 1819)}$	Simulated number of heifers for replacement as a proportion of historical number $\left(\frac{S_k}{H_k}\right)$ for each year of the run.	dimensionless
NOTE: $Y_{9,2}$ through $Y_{9,7}$ to be computed only when $z_{14} = 1978$, otherwise, set to zero.		
$Y_{9,2} = \frac{g_{44,2}}{b_{99}}$	MPAD = mean proportional absolute deviation of simulated (S) heifer numbers from historical (H) numbers: $= \left(\frac{\sum_{i=1951}^{1979} \left \frac{(S_i - H_i)}{H_i} \right }{29 \text{ years}} \right)$	dimensionless
$Y_{9,3} = g_{46,11}$	r = correlation coefficient between the simulated and historical series of heifer recruitment numbers.	dimensionless
$Y_{9,4} = g_{46,12}$	Theil's U = inequality coefficient for comparing simulated changes with historical changes in numbers of heifers recruited.	dimensionless

OUTPUT FUNCTIONS: HEIFER RECRUITMENT STATISTICS (cont.)

$Y_{9,5} = g_{46,13}$	Theil's U^m = proportion of inequality due to mean bias	dimensionless
$Y_{9,6} = g_{46,14}$	Theil's U^s = proportion of inequality due to unequal variance.	dimensionless
$Y_{9,7} = g_{46,15}$	Theil's U^c = proportion of inequality due to imperfect covariation. NOTE: $U^m + U^s + U^c = 1.0$	dimensionless
$Y_{9,8} = g_{43,2}$	for plots	million head
$Y_{9,9} = b_{(z_{14}-1819)}$		million head

OUTPUT FUNCTIONS: TEST STATISTICS COMPARING SIMULATED AND HISTORICAL ANNUAL CULL BEEF COW
NUMBERS SLAUGHTERED IN THE YEAR z_{14}

	Description	Units
$Y_{10,1} = \frac{g_{43,3}}{b(z_{14}-1790)}$	Simulated number of cull beef cows as a proportion of the historical number of beef cows slaughtered $\left(\frac{S_k}{H_k}\right)$ for each year of run.	dimensionless
NOTE: $Y_{10,2}$ through $Y_{10,7}$ to be computed only if $z_{14} = 1978$, otherwise set to zero		
$Y_{10,2} = \frac{g_{44,3}}{b_{99}}$	MPAD = Mean proportional absolute deviation of simulated (S) cull cow numbers from historical (H) beef cow slaughter numbers: $= \left(\frac{\sum_{i=1950}^{1978} \left \frac{S_i - H_i}{H_i} \right }{29 \text{ years}} \right)$	dimensionless
$Y_{10,3} = g_{47,11}$	r = correlation coefficient between changes in simulated beef cull cow numbers and changes in historical beef cow slaughter numbers	dimensionless
$Y_{10,4} = g_{47,12}$	Theil's U = Inequality coefficient for comparing simulated changes in cull beef cow numbers and historical changes in beef cow slaughter numbers.	dimensionless

OUTPUT FUNCTIONS: CULL COW STATISTICS (cont.)

		units
$y_{10,5} = g_{47,13}$	Theil's U^m = proportion of inequality due to mean bias	dimensionless
$y_{10,6} = g_{47,14}$	Theil's U^s = proportion of inequality due to unequal variance.	dimensionless
$y_{10,7} = g_{47,15}$	Theil's U^c = proportion of inequality due to imperfect covariation.	dimensionless
NOTE: $U^m + U^s + U^c = 1.0$		
$y_{10,8} = g_{43,3}$ $y_{10,9} = b_{(z_{14}-1790)}$	for plots	Simulated number of cull beef cows, annual for year z_{14} million head Historical numbers of beef cows slaughtered, annual for year z_{14} million head

OUTPUT FUNCTIONS: TEST STATISTICS COMPARING SIMULATED WITH HISTORICAL ANNUAL NUMBERS
OF CALVES BORN TO BEEF COWS, YEAR z_{14}

	Description	Units
$Y_{11,1} = \frac{g_{43,6}}{b_{(z_{14}-1760)}}$	<p>Simulated number of calves born to beef cows as a proportion of derived historical numbers. $\left(\frac{S_k}{H_k}\right)$ for each year of run</p>	dimensionless
$Y_{11,2} = \frac{g_{44,4}}{b_{99}}$	<p>MPAD = Mean proportional absolute deviation of simulated (S) calf numbers born to beef cows from derived historical (H) numbers:</p> $= \left(\frac{\sum_{i=1950}^{1978} \left \frac{S_i - H_i}{H_i} \right }{29 \text{ years}} \right)$	dimensionless
NOTE: $Y_{11,2}$ through $Y_{11,7}$ are computed only when $z_{14} = 1978$, otherwise set to zero		
$Y_{11,3} = g_{48,11}$	<p>r = correlation coefficient between changes in simulated numbers of calves born to beef cows and changes in derived historical numbers.</p>	dimensionless
$Y_{11,4} = g_{48,12}$	<p>Theils U= Inequality coefficient for comparing simulated changes in numbers of calves born to beef cows and changes in derived historical numbers.</p>	dimensionless

OUTPUT FUNCTIONS: BEEF CALF BIRTH STATISTICS (cont.)

		Units
$Y_{11,5} = g_{48,13}$	Theil's U^m = proportion of inequality due to mean bias.	dimensionless
$Y_{11,6} = g_{48,14}$	Theil's U^s = proportion of inequality due to unequal variance.	dimensionless
$Y_{11,7} = g_{48,15}$	Theil's U^c = proportion of inequality due to imperfect covariance. NOTE: $U^m + U^s + U^c = 1.0$	dimensionless
$Y_{11,8} = g_{43,6}$ $Y_{11,9} = b_{(z_{14}-1760)}$	for plots { Simulated number of calves born to beef cows, annual for year z_{14} Derived historical number of calves born to beef cows, annual for year z_{14}	million head million head

OUTPUT FUNCTIONS (cont.)

Description	Units
j = 1,14	100,000 head
$Y_{12,j} = \begin{cases} Y_{2,j} & ,\text{if } j = 1 \\ Y_{12,(j-1)} + Y_{2,j} & ,\text{if } j > 1 \end{cases}$	

Cummulative total of heifers and cows, exposed for breeding in the year z_{14} , by age. $Y_{12,4}$, for example, is the number of cows and heifers four years old and younger exposed for breeding in the year z_{14} . These numbers are used in plotting the age compositions of the simulated herd through time.

PARAMETER LIST FOR COW VALUE AND DEMOGRAPHY MODEL

Parameter	Value	Units	Description	Used in these functions
b ₁	.940	prop.	estimate of maximum conception rate	g ₁
b ₂	.01	dless	linear correction factor in conception rate formula	g ₁
b ₃	4.0	years	age of cow at which maximum conception rate is expected	g ₁
b ₄	-.006	dless	parabolic bend coefficient in conception rate formula	g ₁
b ₅	-.045	prop.	intercept term in impaired health rate formula	g ₂
b ₆	.25	dless	1/j coefficient in " " " "	g ₂
b ₇	.00104367	dless	j ² coefficient in " " " "	g ₂
b ₈	.99	prop.	intercept term in survival rate formula	g ₃
b ₉	-.001	dless	j coefficient in survival rate formula	g ₃
b ₁₀	.62	dless	proportion of early maturing cows in nat'l beef herd	g ₄ g ₅
b ₁₁	9.75	cwt.	ME: maximum body weight for early maturing cows	g ₄
b ₁₂	1.33015	dless	intercept term in early maturing cow body weight function	g ₄
b ₁₃	-.0239	dless	j coefficient in " " " " " "	g ₄
b ₁₄	-1.1399	dless	1/j coefficient in " " " " " "	g ₄
b ₁₅	11.0	cwt.	ML: maximum body weight for late maturing cows	g ₄ g ₅
b ₁₆	.4107	dless	intercept term in late maturing cow body weight function	g ₄

NOTE: dless indicates dimensionless constant; prop. indicates a proportion

PARAMETER LIST FOR COW VALUE AND DEMOGRAPHY MODEL (cont.)

Parameter	Value	Units	Description	Used in these functions
b ₁₇	.1446	dless	j coefficient in late-maturing cow body weight function	g ₄
b ₁₈	-.01124	dless	j ² coefficient in " " " " " "	g ₄
b ₁₉	.0002673	dless	j ³ " " " " " "	g ₄
b ₂₀	.43	prop	max. calf weight as a proportion of cow weight	g ₆
b ₂₁	.770156	dless	intercept term in calf weaning weight function	g ₆
b ₂₂	.0678788	dless	j coefficient in " " " "	g ₆
b ₂₃	-.00642507	dless	j ² " " " " " "	g ₆
b ₂₄	.000187646	dless	j ³ " " " " " "	g ₆
b ₂₅	.42	prop.	HKB weight as a proportion of max. aggregate cow body weight	g ₇
b ₂₆	.975463	prop.	calf survival rate intercept	g ₈
b ₂₇	-.00184144	dless	j coefficient in calf survival rate function	g ₈
b ₂₈	-.184779	dless	j ² " " " " " "	g ₈
b ₂₉	--	--	} Unassigned	
b ₃₀	--	--		
b ₃₁	--	--		
b ₃₂	--	--		

NOTE: dless indicates a dimensionless constant; prop. indicates a proportion.

PARAMETER LIST FOR COW VALUE AND DEMOGRAPHY MODEL (cont.)

Parameter	Value	Units	Description	Used in these functions
b ₃₃	--	--	Unassigned	
b ₃₄	--	--		
b ₃₅	--	--		
b ₃₆	zero	dless	optional constant "real" interest rate for inflating cost budgets	g ₁₅
b ₃₇	zero	dless	" " " discount rate for present value calculations	g ₂₆
b ₃₈	.93	dless	ratio of heifer & steer average price to Choice feeder steers	g ₂₅
b ₃₉	.96	dless	ratio of HKB salvage value price to feeder steer price	g ₁₄
b ₄₀	1.2	dless	scaling multiplier for price difference between calves & cull cows	g ₁₃ g ₁₄
b ₄₁	1.0	dless	hyperbolic age factor for " " " " " " " "	g ₁₃ g ₁₄
b ₄₂	1.0	dless	interest rate multiplier for adjusting P.C.A. interest rates for short term operating loans.	g ₁₅
b ₄₃	0.5	years	exponential term in interest factor: represents fraction of year for which interest is charged	g ₁₅
b ₄₄	2.83	\$/hd.	Base year (1978) marketing and hauling cost/hd. for all classes	g ₁₆
b ₄₅	6.76	\$/hd.	" " " fuel, lube & elec. " " " "	g ₁₆
b ₄₆	9.22	\$/hd.	" " " mach. & bldg. repair " " " "	g ₁₆
b ₄₇	10.00	\$/hd.	" " " bull charges " " " "	g ₁₆
b ₄₈	6.71	\$/hd.	" " " pasture rental cost/hd for weaned heifers (HKB)	g ₁₇
b ₄₉	24.19	\$/hd.	" " " hay " " " " "	g ₁₇

NOTE: dless indicated dimensionless constant.

PARAMETER LIST FOR COW VALUE AND DEMOGRAPHY MODEL (cont.)

Parameter	Value	Units	Description							Used in these functions	
b ₅₀	4.68	\$/hd.	Base year (1978)	Grain & concentrate	cost/hd.	for weaned heifers				g ₁₇	
b ₅₁	.32	\$/hd.	"	"	"	Protein supplement	"	"	"	"	g ₁₇
b ₅₂	1.60	\$/hd.	"	"	"	Salt and mineral	"	"	"	"	g ₁₇
b ₅₃	13.45	\$/hd.	"	"	"	Labor	"	"	"	"	g ₁₇
b ₅₄	1.63	\$/hd.	"	"	"	Veterinary & medicine	"	"	"	"	g ₁₇
b ₅₅	8.50	\$/hd.	"	"	"	Pasture rental	"	for yrlnq. heifers			g ₁₈
b ₅₆	30.65	\$/hd.	"	"	"	Hay	"	(pregnant or not)			g ₁₈
b ₅₇	5.93	\$/hd.	"	"	"	Grain & concentrate	"	"	"	"	g ₁₈
b ₅₈	.40	\$/hd.	"	"	"	Protein supplement	"	"	"	"	g ₁₈
b ₅₉	2.03	\$/hd.	"	"	"	Salt & minerals	"	"	"	"	g ₁₈
b ₆₀	39.54	\$/hd.	"	"	"	Labor	"	for preg. yr. heifers			g ₁₉
b ₆₁	4.80	\$/hd.	"	"	"	Veterinary & medicine	"	"	"	"	g ₁₉
b ₆₂	13.45	\$/hd.	"	"	"	Labor	"	" non-preg yr. heifers			g ₂₀
b ₆₃	1.63	\$/hd.	"	"	"	Veterinary & medicine	"	"	"	"	g ₂₀
b ₆₄	8.94	\$/hd.	"	"	"	Pasture rental	"	for mature cows			g ₂₁
b ₆₅	32.25	\$/hd.	"	"	"	Hay	"	(preg or not)			g ₂₁
b ₆₆	6.24	\$/hd.	"	"	"	Grain & concentrate	"	"	"	"	g ₂₁
b ₆₇	.42	\$/hd.	"	"	"	Protein supplement	"	"	"	"	g ₂₁
b ₆₈	2.14	\$/hd.	"	"	"	Salt and minerals	"	"	"	"	g ₂₁

PARAMETER LIST FOR COW VALUE AND DEMOGRAPHY MODEL (cont.)

Parameter	Value	Units	Description	Used in these functions
b ₆₉	27.54	\$/hd	Base Year (1978) labor cost/hd for preg. mature cows	g ₂₂
b ₇₀	3.35	\$/hd.	" " " veterinary & medicine " " " " "	g ₂₂
b ₇₁	13.45	\$/hd.	" " " labor cost/hd for non-preg mature cows	g ₂₃
b ₇₂	1.63	\$/hd.	" " " veterinary & medicine " " " " "	g ₂₃
b ₇₃	.27	dless	weight of previous year's feeder steer price in expected feeder price model	} g _{12,1}
b ₇₄	.73	dless		
b ₇₅	.27	dless	" " previous " Utility cow price in expected utility price model	} g _{12,2}
b ₇₆	.73	dless		
b ₇₇	--	--	Unassigned	
b ₇₈	--	--		
b ₇₉	--	--		
b ₈₀	1.0	dless	multiplier for adjusting P.C.A. interest rate in the discount terms used in PVB calculations	g _{26,1}
b ₈₁	1.0	years	allowable time horizon, beyond first year, for present value calculations (PVB)	} g _{27,j} for j=2,14
b ₈₂	1.0	dless	critical V-ratio (PVB _j / FSV _j) for variable final culling age decisions	

NOTE: dless indicates a dimensionless constant

PARAMETER LIST FOR COW VALUE AND DEMOGRAPHY MODEL (cont.)

Parameter	Value	Units	Description	Used in these functions
b ₈₃	-5.5	dless	exponential v-ratio factor in retainment function for preg. cows	} g ₃₇
b ₈₄	.53	dless	critical v-ratio (inflection) in " " " " "	
b ₈₅	-5.5	dless	exponential v-ratio factor in retainment function for open cows	} g ₃₈
b ₈₆	.535	dless	critical v-ratio (inflection) in " " " " "	
b ₈₇	.5	dless	fraction of weaned heifers not kept for breeding which are possibly available the following year for recruitment for breeding	f _{1,1}
b ₈₈	0	prop	minimum proportion of pregnant cows to be retained	} g ₃₇
b ₈₉	.20	prop	minimum prop. of weaned and non-pregnant yearling heifers to be retained	
b ₉₀	0	prop	minimum prop. of non-pregnant cows allowed to be retained	} g ₃₈
b ₉₁	1.0	prop	maximum prop. of healthy non-pregnant cows to be retained	
b ₉₂	-5.5	dless	exponential v-ratio factor in retainment function for weaned and non-pregnant yearling heifers	
b ₉₃	1.1	dless	critical v-ratio (inflection) in retainment function for weaned and non-pregnant yearling heifers	
b ₉₄	.80	prop	maximum proportion of healthy weaned heifers allowed to be kept for breeding	

NOTE: "dless" indicates a dimensionless constant; "prop" indicates proportion

PARAMETER LIST FOR COW VALUE AND DEMOGRAPHY MODEL (cont.)

<u>Parameter</u>	<u>Value</u>	<u>Units</u>	<u>Description</u>	<u>Used in these functions</u>
b ₉₅	0	prop	proportion of pregnant yearling heifers counted in sum of heifers recruited	g _{43,2}
b ₉₆	1.0	prop	proportion of weaned heifers kept for breeding counted in sum of heifers recruited	g _{43,2}
b ₉₇	0	prop	proportion of non-pregnant yearling heifers counted in sum of heifers recruited	g _{43,2}
b ₉₈	1.0	prop	proportion of pregnant yearling heifers included in beef cow herd inventory	g _{43,1}
b ₉₉	29	years	number of years in a simulation run (1950-1978)	y _{i,2} i=8,9,10,11
b ₁₀₀	28	years	number of periods for which proportional changes are computed in a simulation run, for statistical comparison of simulated and historical series	g _{4i,j} i=5,6,7,8 j=9,10,11,12 13,14,15

NOTE: prop indicates proportion

TEST PARAMETERS: HISTORICAL SERIES ON U.S. BEEF HEIFER NUMBERS FOR BREEDING

Parameter	Value	Units	Description	Used in these functions
b ₁₃₁	4.246	million	Jan. 1, 1951, USDA estimated inventory of beef heifers for breeding.	} g _{44,2} g _{46,2}
b ₁₃₂	5.435	head	1952	
b ₁₃₃	6.780	"	1953	
b ₁₃₄	5.740	"	1954	
b ₁₃₅	5.320	"	1955	
b ₁₃₆	4.716	"	1956	
b ₁₃₇	4.587	"	1957	
b ₁₃₈	3.507	"	1958	
b ₁₃₉	3.281	"	1959	
b ₁₄₀	4.124	"	1960	
b ₁₄₁	3.838	"	1961	
b ₁₄₂	4.457	"	1962	
b ₁₄₃	4.511	"	1963	
b ₁₄₄	5.409	"	1964	
b ₁₄₅	5.397	"	1965	
b ₁₄₆	5.337	"	1966	
b ₁₄₇	5.351	"	1967	
b ₁₄₈	5.710	"	1968	
b ₁₄₉	6.320	"	1969	
b ₁₅₀	5.768	"	1970	
b ₁₅₁	5.864	"	1971	
b ₁₅₂	6.675	"	1972	
b ₁₅₃	6.901	"	1973	
b ₁₅₄	8.692	"	1974	
b ₁₅₅	8.276	"	1975	
b ₁₅₆	6.793	"	1976	
b ₁₅₇	5.904	"	1977	
b ₁₅₈	5.219	"	1978	
b ₁₅₉	5.574	"	1979 Estimated Jan. 1 inventory of beef heifers for replacements (Interpolation between July 1, 1978 and July 1, 1979 inventories in August 1980 <u>Livestock and Meat Situation, P.</u>)	

TEST PARAMETERS : HISTORICAL SERIES ON U.S. BEEF COW SLAUGHTER

Parameter	Value	Units		Used in these functions
b ₁₆₀	2.204	million	1950	SOURCE: USDA data file named "COWKSNF" (USDA, ESS, T-Dam, 1979). Used in test statistics and for plotting against model's total number of cows culled as becoming 3 years old and over.
b ₁₆₁	1.465	head	1951	
b ₁₆₂	2.521	"	1952	
b ₁₆₃	4.535	"	1953	
b ₁₆₄	4.619	"	1954	
b ₁₆₅	5.042	"	1955	
b ₁₆₆	5.027	"	1956	
b ₁₆₇	4.474	"	1957	
b ₁₆₈	2.106	"	1958	
b ₁₆₉	1.577	"	1959	
b ₁₇₀	2.631	"	1960	
b ₁₇₁	1.964	"	1961	
b ₁₇₂	2.064	"	1962	
b ₁₇₃	1.835	"	1963	
b ₁₇₄	3.279	"	1964	
b ₁₇₅	4.629	"	1965	
b ₁₇₆	4.397	"	1966	
b ₁₇₇	3.876	"	1967	
b ₁₇₈	4.099	"	1968	
b ₁₇₉	4.411	"	1969	
b ₁₈₀	3.845	"	1970	
b ₁₈₁	4.174	"	1971	
b ₁₈₂	3.777	"	1972	
b ₁₈₃	3.832	"	1973	
b ₁₈₄	5.298	"	1974	
b ₁₈₅	9.186	"	1975	
b ₁₈₆	8.414	"	1976	
b ₁₈₇	7.657	"	1977	
b ₁₈₈	6.263	"	1978	
b ₁₈₉	unassigned			

^g_{44,3}

^g_{47,2}

TEST PARAMETERS : DERIVED HISTORICAL SERIES ON CALVES BORN TO BEEF COWS IN THE U.S.

Parameter	value	Units	Description	Used in these functions
b ₁₉₀	14.66	million	1950 estimate of number of calves born to beef cows in U.S., derived	} g _{44,4} g _{48,2}
b ₁₉₁	15.77	head	1951 as the residual obtained by subtracting (.92)x Dairy cow	
b ₁₉₂	18.72	"	1952 numbers) from total calves born in the U.S. annually)	
b ₁₉₃	21.44	"	1953	
b ₁₉₄	22.58	"	1954	
b ₁₉₅	22.50	"	1955	
b ₁₉₆	22.28	"	1956 SOURCE: USDA data file named "COWSNMC" and "CALSC",	
b ₁₉₇	21.31	"	1957 for dairy cow numbers and total calves born,	
b ₁₉₈	21.14	"	1958 respectively, (USDA, ESS, T-Dam, 1979). Used in	
b ₁₉₉	22.18	"	1959 test statistics and for plotting against models	
b ₂₀₀	23.18	"	1960 total number of calves born to beef cows.	
b ₂₀₁	24.18	"	1961	
b ₂₀₂	25.72	"	1962	
b ₂₀₃	27.03	"	1963	
b ₂₀₄	29.13	"	1964	
b ₂₀₅	29.77	"	1965	
b ₂₀₆	30.21	"	1966	
b ₂₀₇	31.17	"	1967	
b ₂₀₈	32.25	"	1968	
b ₂₀₉	33.63	"	1969	
b ₂₁₀	34.75	"	1970	
b ₂₁₁	35.78	"	1971	
b ₂₁₂	36.84	"	1972	
b ₂₁₃	38.50	"	1973	
b ₂₁₄	40.47	"	1974	
b ₂₁₅	39.86	"	1975	
b ₂₁₆	37.24	"	1976	
b ₂₁₇	35.93	"	1977	
b ₂₁₈	33.78	"	1978	

APPENDIX B

STATISTICAL FORMULAE

Derivation of a computational formula for the standard deviation of the population, P_i

Beginning with the common form,
$$S_P = \sqrt{\frac{\sum (P - \bar{P})^2}{n}} ,$$

expand to

$$S_P = \sqrt{\frac{\sum (P^2 - 2P\bar{P} + \bar{P}^2)}{n}} ,$$

which may be written as

$$S_P = \sqrt{(\sum P^2 - 2\bar{P} \sum P + \sum \bar{P}^2) / n} .$$

Multiply numerator and denominator by n ,

$$S_P = \sqrt{[(n\sum P^2) - (2n\bar{P}\sum P) + (n\sum \bar{P}^2)] / n^2} .$$

Since $n\bar{P}^2 = \sum \bar{P}^2$, substitute

$$S_P = \sqrt{[(n\sum P^2) - (2n\bar{P}\sum P) + (n^2\bar{P}^2)] / n^2} .$$

Since $\sum P/n = \bar{P}$, substitute

$$S_P = \sqrt{[n\sum P^2 - (2n(\sum P/n)\sum P) + n^2(\sum P/n)^2] / n^2} ,$$

then collect and cancel terms

$$S_P = \sqrt{\frac{n\sum P^2 - (\sum P)^2}{n^2}} \quad \text{or} \quad = \quad \frac{1}{n} \sqrt{n\sum P^2 - (\sum P)^2}$$

These are convenient computational forms because they do not require calculating differences from the mean (\bar{P}). They are used in the functions $g_{45,j}$, $g_{46,j}$, $g_{47,j}$ and $g_{48,j}$; where $j=1$ and 2 (S_P for $j = 1$ and S_A for $j = 2$).

Derivation of a computational formula for the product-moment coefficient of correlation, r , of two series P_i and A_i

Beginning with the common form:
$$r = \frac{\frac{1}{n} \sum (P - \bar{P})(A - \bar{A})}{S_P S_A} ,$$

Expand:

$$r = \frac{\frac{1}{n} \sum (PA - P\bar{A} - \bar{P}A + \bar{P}\bar{A})}{S_P S_A} ,$$

multiply numerator and denominator by n ,

$$r = \frac{\sum PA - (\sum P)\bar{A} - \bar{P}(\sum A) + \sum \bar{P}\bar{A}}{n S_P S_A} ,$$

substitute $n \bar{P}\bar{A} = \sum \bar{P}\bar{A}$, $(\sum P/n) = \bar{P}$ and $(\sum A/n) = \bar{A}$,

$$r = \frac{\sum PA - (\sum P)(\sum A)/n - (\sum P)(\sum A)/n + n(\sum P/n)(\sum A/n)}{n S_P S_A} ,$$

multiply numerator and denominator by n ,

$$r = \frac{n\sum PA - 2(\sum P)(\sum A) + (\sum P)(\sum A)}{n^2 S_P S_A} ,$$

and collect terms,

$$r = \frac{n \sum PA - (\sum P)(\sum A)}{n^2 S_P S_A} .$$

This formula for the correlation coefficient is used in functions $g_{45,11}$, $g_{46,11}$, $g_{47,11}$ and $g_{48,11}$.

Verification of Theil's (1966) decomposition of the numerator in his inequality coefficient, U

Theil asserts: $\frac{1}{n} \sum (P-A)^2 = (\bar{P}-\bar{A})^2 + (S_P - S_A)^2 + 2(1-r) S_P S_A$

expanded first term on RHS: $(\bar{P}-\bar{A})^2 = (\sum P/n - \sum A/n)^2 = (1/n^2) (\sum P - \sum A)^2 = 1/n^2 \left[(\sum P)^2 - 2(\sum P)(\sum A) + (\sum A)^2 \right]$

expand second term on RHS: $(S_P - S_A)^2 = S_P^2 - 2 S_P S_A + S_A^2 = \left(\frac{n \sum P^2 - (\sum P)^2 + n \sum A^2 - (\sum A)^2}{n^2} \right) - 2 S_P S_A$

and expand third term on RHS: $2(1-r) S_P S_A = 2 S_P S_A - 2 S_P S_A \cdot \left\{ \frac{n \sum PA - (\sum P)(\sum A)}{n^2 S_P S_A} \right\}$

recombine the three expanded terms, after cancelling the $(2S_P S_A)$ subterms and factoring out $1/n^2$.

$$1/n^2 \left[(\sum P)^2 - 2(\sum P)(\sum A) + (\sum A)^2 + n \sum P^2 - (\sum P)^2 + n \sum A^2 - (\sum A)^2 - 2n \sum PA + 2(\sum P)(\sum A) \right]$$

collecting terms and factoring gives:

$$1/n^2 \left[n \sum P^2 - 2n \sum PA + n \sum A^2 \right] = (1/n) \left[\sum P^2 - 2 \sum PA + \sum A^2 \right] = (1/n) \sum (P-A)^2$$

Q.E.D.

APPENDIX C

SOURCE FILE CODE

User Notes On The Model Program Source File

The source file code for the beef cow value and demography model has been formulated for FLEX4 processing with FORTRAN IV. Users will note that the first 10 intermediate functions ($g_{i,j}$, $i = 1,10$) are functions of b parameters only. To save computational time of recalculating these in each year of the 29 year run, they are calculated only in the first year as b parameters (b_{225} through b_{338}) which remain constant through the length of the run. In all subsequent time steps of a run, then, the first 10 vectors of g functions are set equal to their corresponding b parameters.

```

SUBROUTINE ZCOMP
COMMON/GLOBAL/IFLAG(30)
COMMON/RNPROC/IDRUN(2),ITIME,MTV(12)
COMMON/MODULE/JC1,JX,JY,JZ,JB,JF,JG,JH,JD2,JJ,K,KP,KPP,
+ IPCR(187),VARD(66),X(2,15),XU(2,15),Y(12,15),Z(1,15),B(340),
+ F(2,15),G(48,15)
C*
DIMENSION ZINIT(14,29)
C*
IF (MTV(1).NE.IFLAG(4)) GO TO 50
DO 3 J=1,29
READ(9,900) (ZINIT(I,J),I=1,13),IZ14
ZINIT(14,J) = FLOAT(IZ14)
3 CONTINUE
900 FORMAT (2F8.4,11F7.4,2X,I4)
JPJ=1
C*
B(282) = B(10) * B(11) + (1. - B(10)) * B(15)
B(296) = B(282) * B(25)
DO 30 J=1,15
AJ = FLOAT(J)
IF (J.GT.1) GO TO 20
B(224+J) = B(1)+B(2)*(AJ - B(3))+B(4)*(AJ - B(3))*(AJ - B(3))
B(238+J) = 1.0 - (B(5)+B(6)/AJ+B(7) * AJ * AJ)
B(309+J) = 1.0
GO TO 30
C*
20 CONTINUE
IF (J.NE.15) B(224+J) = B(1) + B(2) * (AJ - B(3)) +
1 B(4) * (AJ - B(3)) * (AJ - B(3))
B(238+J) = 1.0 - (B(5) + B(6)/AJ + B(7) * AJ * AJ)
B(252+J) = B(8) + B(9) * AJ
B(266+J) = B(10) * B(11) * (B(12) + B(13)*AJ + B(14)/AJ) +
1 (1.0 - B(10)) * B(15) * (B(16) + B(17) * AJ + B(18) * AJ * AJ +
2 B(19) * AJ * AJ * AJ)
IF (J.NE.15) B(281+J) = B(282) * B(20) * (B(21) + B(22) * AJ +
1 B(23) * AJ * AJ + B(24) * AJ * AJ * AJ)
IF (J.NE.15) B(295+J) = B(26) + B(27) * AJ + B(28)/AJ
B(309+J) = B(308+J) * B(223+J) * B(238+J) * B(252+J)
C*
30 CONTINUE
C*
DO 40 J=1,14
B(324+J) = (B(309+J) * B(253+J) - B(310+J)) / B(309+J)
C*
50 DO 60 I=1,14
WRITE(12,801) I,ZINIT(I,JPJ)
801 FORMAT(2X,*THIS IS Z(1,*,I2,*) = *,F20.10)
60 Z(1,I)=ZINIT(I,JPJ)
JPJ=JPJ+1
C*
RETURN
END
SUBROUTINE GCOMP
COMMON/MODULE/JD1,JX,JY,JZ,JB,JF,JG,JH,JD2,JJ,K,KP,KPP,
+ IPCR(187),VARD(66),X(2,15),XU(2,15),Y(12,15),Z(1,15),B(340),
+ F(2,15),G(48,15)
C*
IZ14 = IFIX(Z(1,14))
DO 10 J=1,JJ
IF (J.NE.15) G(1,J) = B(224+J)
G(2,J) = B(238+J)
IF (J.NE.1) G(3,J) = B(252+J)

```



```

IF (J.NE.1) G(4,J) = B(266+J)
IF (J.NE.1.AND.J.NE.15) G(6,J) = B(281+J)
IF (J.NE.1.AND.J.NE.15) G(8,J) = B(295+J)
G(9,J) = B(309+J)
IF (J.NE.15) G(10,J) = B(324+J)
10 CONTINUE
G(5) = B(282)
G(7) = B(296)
G(12,1) = B(73)*ZM(1,1,1) + B(74)*Z(1,1)
G(12,2) = B(75)*ZM(1,1,2) + B(76)*Z(1,2)
DO 30 J=1,15
IF (J.EQ.1) G(13,J) = G(12,1)*G(7)*B(39)
IF (J.NE.1) G(13,J) = G(4,J)*(G(12,1)-B(40)*(G(12,1)-G(12,2)) +
1 B(40)*(G(12,1)-G(12,2))/(FLOAT(J)*B(41)))
IF (J.EQ.1) G(14,J) = Z(1,1) * G(7) * B(39)
IF (J.NE.1) G(14,J)=G(4,J)*(Z(1,1)-B(40)*(Z(1,1) - Z(1,2)) +
1 B(40) * (Z(1,1) - Z(1,2))/(FLOAT(J) * B(41)))
30 CONTINUE
G(15) = (1.0 + B(42) * Z(1,13) + B(36)) ** B(43)
G(16) = B(44) * Z(1,11) + B(45) * Z(1,3) + B(46) * Z(1,4) +
1 B(47) * Z(1,5)
G(17) = (G(16)+B(48)*Z(1,6) + B(49) * Z(1,7) + B(50) * Z(1,8) +
1 B(51) * Z(1,9) + B(52) * Z(1,10) + B(53) * Z(1,11) +
2 B(54) * Z(1,12)) * G(15)
G(18) = B(55) * Z(1,6) + B(56) * Z(1,7) + B(57) * Z(1,8) +
1 B(58) * Z(1,9) + B(59) * Z(1,10)
G(19) = (G(16) + G(18)+B(60) * Z(1,11)+B(61) * Z(1,12)) * G(15)
G(20) = (G(16) + G(18)+B(62) * Z(1,11)+B(63) * Z(1,12)) * G(15)
G(21) = B(64) * Z(1,6)+B(65) * Z(1,7)+B(66) * Z(1,8) +
1 B(67) * Z(1,9)+B(68) * Z(1,10)
G(22) = (G(16) + G(21)+B(69) * Z(1,11)+B(70) * Z(1,12)) * G(15)
G(23) = (G(16) + G(21)+B(71) * Z(1,11) + B(72) * Z(1,12)) * G(15)
DO 40 J=1,14
IF (J.LT.2.OR.J.GT.13) GO TO 35
IF (J.EQ.2) G(24,J) = G(10,2) * G(13,3) - G(20)
IF (J.GT.2) G(24,J) = G(10,J) * G(13,J+1) - G(23)
35 IF (J.EQ.1) G(25,J) = G(10,1) * G(13,2) - G(17)
IF (J.EQ.2) G(25,J) = G(10,2) * G(13,3) - G(19) + G(8,2)*G(6,2) *
1 G(12,1) * B(38)
IF (J.GT.2) G(25,J) = G(10,J) * G(13,J+1) - G(22) + G(8,J)*G(6,J) *
1 G(12,1) * B(38)
40 CONTINUE
G(26,1) = 1.0/(1.0 + B(80) * Z(1,13) + B(37))
G(28,1) = (G(9,15)/G(9,14) * G(13,15) + G(25,14)) * G(26,1)
G(29,1) = G(28,1)/G(13,14)
DO 50 J= 2,14
IF (J.EQ.2.AND.G(29,J-1).GE.B(82)) G(27,J)=AMIN1(15.0,14.0+B(81))
IF (J.GT.2.AND.G(29,J-1).GE.B(82)) G(27,J) = AMIN1(G(27,J-1),16.0
1 - FLOAT(J) + B(81))
IF (J.GT.1.AND.G(29,J-1).LT.B(82)) G(27,J) = 16.0 - FLOAT(J)
IG = IFIX(G(27,J))
G(28,J) = G(9,IG)/G(9,15-J) * G(13,IG) * (G(26,1)) ** (IG-15+J)
IGG = IG - 15 + J
DO 45 I=1,IGG
45 G(28,J) = G(28,J)+(G(9,14+I-J)/G(9,15-J)*G(25,14+I-J))*G(26,1)**I
G(29,J) = G(28,J)/G(13,15-J)
50 CONTINUE
DO 60 J=1,13
JKK = J + 1
G(30,JKK) = G(28,15-JKK)/G(14,JKK)
IF (J.NE.1) G(31,J) = G(28,15-J) - (G(25,J) - G(24,J)) * G(26,1)
IF (J.EQ.1) G(32,J) = G(28,14)/G(14,1)
IF (J.GT.1) G(32,J) = G(31,J)/G(14,J)

```

```

IF (JKK.EQ.2) G(34,JKK) = X(2,1) * G(3,2) * G(1,1)
IF (JKK.GT.2) G(34,JKK) = (X(1,JKK-1) + X(2,JKK-1)) * G(3,JKK) * G(1,JKK-1)
60 CONTINUE
DO 70 J=1,14
IF (J.NE.1) GO TO 62
G(35,J) = 0.0
DO 61 I=2,14
G(35,J) = G(35,J) + X(1,I) * G(8,I)
61 CONTINUE
G(35,J) = .5 * G(35,J)
GO TO 65
62 IF (J.NE.2) GO TO 64
G(35,J) = X(2,1) * G(3,2) * (1.0 - G(1,1)) + X(1,1)
GO TO 65
64 G(35,J) = (X(1,J-1) + X(2,J-1)) * G(3,J) * (1.0 - G(1,J-1))
65 CONTINUE
IF (J.NE.1) G(37,J) = B(88) + (G(2,J) - B(88)) / (1.0 + EXP(B(83) *
1 (G(30,J) - B(84))))
IF (J.LT.3) G(38,J) = B(89) + (B(90) * G(2,J) - B(89)) / (1.0 + EXP(B(92) *
1 (G(32,J) - B(93))))
IF (J.GT.2.AND.J.NE.14) G(38,J) = B(90) + (B(91) * G(2,J) - B(90)) /
1 (1.0 + EXP(B(85) * (G(32,J) - B(86))))
IF (J.NE.1) G(39,J) = G(34,J) * G(37,J)
IF (J.NE.14) G(40,J) = G(35,J) * G(38,J)
70 CONTINUE
DO 71 J=1,14
JKK = J + 1
IF (JKK.LT.15) G(41,JKK) = G(34,JKK) - G(39,JKK)
IF (JKK.EQ.15) G(41,JKK) = X(1,14) * G(3,15)
IF (J.LT.14) G(42,J) = G(35,J) - G(40,J)
IF (J.EQ.14) G(42,J) = G(35,14)
71 CONTINUE
DO 72 J=1,14
72 G(43,J) = 0.0
G(43,1) = B(98) * G(39,2) * 0.1
DO 75 I=2,15
IF (I.GE.3.AND.I.LE.13) G(43,1) = G(43,1) + (G(39,I) + G(40,I)) * 0.1
IF (I.EQ.14) G(43,1) = G(43,1) + G(39,I) * 0.1
IF (I.GE.3.AND.I.LE.14) G(43,3) = G(43,3) + (G(41,I) + G(42,I)) * 0.1
IF (I.EQ.15) G(43,3) = G(43,3) + G(41,I) * 0.1
IF (I.GE.2.AND.I.LE.14) G(43,4) = G(43,4) + X(1,I) * G(8,I)
IF (I.GE.2.AND.I.LE.13) G(43,5) = G(43,5) + X(1,I) + X(2,I)
IF (I.EQ.14) G(43,5) = G(43,5) + X(2,I)
IF (I.GE.2.AND.I.LE.14) G(43,6) = G(43,6) + X(1,I) * G(3,I+1) * 0.1
75 CONTINUE
G(43,2) = (B(95) * G(39,2) + B(96) * G(40,1) + B(97) * G(40,2)) * 0.1
G(44,1) = GM(44,1,1) + ABS(G(43,1) - B(IZ14-1849)) /
1 B(IZ14-1849)
G(44,2) = GM(44,1,2) + ABS(G(43,2) - B(IZ14-1819)) /
1 B(IZ14-1819)
G(44,3) = GM(44,1,3) + ABS(G(43,3) - B(IZ14-1790)) /
1 B(IZ14-1790)
G(44,4) = GM(44,1,4) + ABS(G(43,6) - B(IZ14-1760)) /
1 B(IZ14-1760)
IF (IZ14.EQ.1950) GO TO 100

C
G(45,1) = (G(43,1) - GM(43,1,1)) / GM(43,1,1)
G(45,2) = (B(IZ14-1849) - B(IZ14-1850)) / B(IZ14-1850)
G(45,3) = GM(45,1,3) + G(45,1)
G(45,4) = GM(45,1,4) + G(45,1) * G(45,1)
G(45,5) = GM(45,1,5) + G(45,2)
G(45,6) = GM(45,1,6) + G(45,2) * G(45,2)
G(45,7) = GM(45,1,7) + G(45,1) * G(45,2)

```

$G(45,8) = GM(45,1,8) + (G(45,1) - G(45,2)) * (G(45,1) - G(45,2))$
C
 $G(46,1) = (G(43,2) - GM(43,1,2))/GM(43,1,2)$
 $G(46,2) = (B(IZ14-1819) - B(IZ14-1820))/B(IZ14-1820)$
 $G(46,3) = GM(46,1,3) + G(46,1)$
 $G(46,4) = GM(46,1,4) + G(46,1) * G(46,1)$
 $G(46,5) = GM(46,1,5) + G(46,2)$
 $G(46,6) = GM(46,1,6) + G(46,2) * G(46,2)$
 $G(46,7) = GM(46,1,7) + G(46,1) * G(46,2)$
 $G(46,8) = GM(46,1,8) + (G(46,1) - G(46,2)) * (G(46,1) - G(46,2))$
C
 $G(47,1) = (G(43,3) - GM(43,1,3))/GM(43,1,3)$
 $G(47,2) = (B(IZ14-1790) - B(IZ14-1791))/B(IZ14-1791)$
 $G(47,3) = GM(47,1,3) + G(47,1)$
 $G(47,4) = GM(47,1,4) + G(47,1) * G(47,1)$
 $G(47,5) = GM(47,1,5) + G(47,2)$
 $G(47,6) = GM(47,1,6) + G(47,2) * G(47,2)$
 $G(47,7) = GM(47,1,7) + G(47,1) * G(47,2)$
 $G(47,8) = GM(47,1,8) + (G(47,1) - G(47,2)) * (G(47,1) - G(47,2))$
C
 $G(48,1) = (G(43,6) - GM(43,1,6))/GM(43,1,6)$
 $G(48,2) = (B(IZ14-1760) - B(IZ14-1761))/B(IZ14-1761)$
 $G(48,3) = GM(48,1,3) + G(48,1)$
 $G(48,4) = GM(48,1,4) + G(48,1) * G(48,1)$
 $G(48,5) = GM(48,1,5) + G(48,2)$
 $G(48,6) = GM(48,1,6) + G(48,2) * G(48,2)$
 $G(48,7) = GM(48,1,7) + G(48,1) * G(48,2)$
 $G(48,8) = GM(48,1,8) + (G(48,1) - G(48,2)) * (G(48,1) - G(48,2))$
C
IF (IZ14.NE.1978) GO TO 100
C
 $G(45,9) = \text{SQRT}(B(100) * G(45,4) - G(45,3) * G(45,3))/B(100)$
 $G(45,10) = \text{SQRT}(B(100) * G(45,6) - G(45,5) * G(45,5))/B(100)$
 $G(45,11) = (B(100) * G(45,7) - G(45,3) * G(45,5)) /$
1 $(B(100) * B(100) * G(45,9) * G(45,10))$
 $G(45,12) = \text{SQRT}(G(45,8)/G(45,6))$
 $G(45,13) = (G(45,3) - G(45,5)) * (G(45,3) - G(45,5)) / (B(100) * G(45,8))$
 $G(45,14) = B(100) * (G(45,9) - G(45,10)) * (G(45,9) - G(45,10)) / G(45,8)$
 $G(45,15) = 2.0 * B(100) * (1.0 - G(45,11)) * G(45,9) * G(45,10) / G(45,8)$
C
 $G(46,9) = \text{SQRT}(B(100) * G(46,4) - G(46,3) * G(46,3))/B(100)$
 $G(46,10) = \text{SQRT}(B(100) * G(46,6) - G(46,5) * G(46,5))/B(100)$
 $G(46,11) = (B(100) * G(46,7) - G(46,3) * G(46,5)) /$
1 $(B(100) * B(100) * G(46,9) * G(46,10))$
 $G(46,12) = \text{SQRT}(G(46,8)/G(46,6))$
 $G(46,13) = (G(46,3) - G(46,5)) * (G(46,3) - G(46,5)) / (B(100) * G(46,8))$
 $G(46,14) = B(100) * (G(46,9) - G(46,10)) * (G(46,9) - G(46,10)) / G(46,8)$
 $G(46,15) = 2.0 * B(100) * (1.0 - G(46,11)) * G(46,9) * G(46,10) / G(46,8)$
C
 $G(47,9) = \text{SQRT}(B(100) * G(47,4) - G(47,3) * G(47,3))/B(100)$
 $G(47,10) = \text{SQRT}(B(100) * G(47,6) - G(47,5) * G(47,5))/B(100)$
 $G(47,11) = (B(100) * G(47,7) - G(47,3) * G(47,5)) /$
1 $(B(100) * B(100) * G(47,9) * G(47,10))$
 $G(47,12) = \text{SQRT}(G(47,8)/G(47,6))$
 $G(47,13) = (G(47,3) - G(47,5)) * (G(47,3) - G(47,5)) / (B(100) * G(47,8))$
 $G(47,14) = B(100) * (G(47,9) - G(47,10)) * (G(47,9) - G(47,10)) / G(47,8)$
 $G(47,15) = 2.0 * B(100) * (1.0 - G(47,11)) * G(47,9) * G(47,10) / G(47,8)$
C
 $G(48,9) = \text{SQRT}(B(100) * G(48,4) - G(48,3) * G(48,3))/B(100)$
 $G(48,10) = \text{SQRT}(B(100) * G(48,6) - G(48,5) * G(48,5))/B(100)$
 $G(48,11) = (B(100) * G(48,7) - G(48,3) * G(48,5)) /$
1 $(B(100) * B(100) * G(48,9) * G(48,10))$
 $G(48,12) = \text{SQRT}(G(48,8)/G(48,6))$

```

G(48,13) = (G(48,3)-G(48,5))*(G(48,3)-G(48,5))/(B(100)*G(48,8))
G(48,14) = B(100)*(G(48,9)-G(48,10))*(G(48,9)-G(48,10))/G(48,8)
G(48,15) = 2.0 * B(100)*(1.0 - G(48,11))*G(48,9)*G(48,10)/G(48,8)
C
100 CONTINUE
C
RETURN
END
SUBROUTINE FCOMP
COMMON/GLOBAL/IFLAG(30),MAP(8,81)
COMMON/RNPROC/IDRUN(2),ITIME,MTV(12),IGPTR,IMPTR,IERR
COMMON/MODULE/JD1,JX,JY,JZ,JB,JF,JG,JH,JD2,JJ,K,KP,KPP,
+ IPCR(187),VARD(66),X(2,15),XU(2,15),Y(12,15),Z(1,15),B(340),
+ F(2,15),G(48,15)
IF(IPCR(76).NE.0)GO TO 5
CALL POP2
RETURN
5 CONTINUE
WRITE(3,201)
201 FORMAT(1X,*SUBROUTINES PROCESSED*)
IM=ITIME+1
MTV(IM)=MTV(IM)+1
CALL POP2
RETURN
END
SUBROUTINE FCOMP
COMMON/MODULE/JD1,JX,JY,JZ,JB,JF,JG,JH,JD2,JJ,K,KP,KPP,
+ IPCR(187),VARD(66),X(2,15),XU(2,15),Y(12,15),Z(1,15),B(340),
+ F(2,15),G(48,15)
C*
DO 10 J=1,14
IF (J.EQ.1) F(1,J) = G(42,1) * B(87) - X(1,1)
IF (J.NE.1) F(1,J) = G(39,J) - X(1,J)
IF (J.NE.14) F(2,J) = G(40,J) - X(2,J)
10 CONTINUE
DO 110 I=1,2
110 WRITE(10,903) I,(F(I,J),J=1,15)
903 FORMAT(* F(*,I2,*, J) =*,15(F8.3))
C*
RETURN
END
SUBROUTINE HCOMP
COMMON/MODULE/JD1,JX,JY,JZ,JB,JF,JG,JH,JD2,JJ,K,KP,KPP,
+ IPCR(187),VARD(66),X(2,15),XU(2,15),Y(12,15),Z(1,15),B(340),
+ F(2,15),G(48,15)
RETURN
END
SUBROUTINE YCOMP
COMMON/MODULE/JD1,JX,JY,JZ,JB,JF,JG,JH,JD2,JJ,K,KP,KPP,
+ IPCR(187),VARD(66),X(2,15),XU(2,15),Y(12,15),Z(1,15),B(340),
+ F(2,15),G(48,15)
C
IZ14 = IFIX(Z(1,14))
IF (IPCR(49).NE.0) GO TO 1
905 FORMAT(*1*/4X,*J = *,3X,15(3X,I3,2X))
C
1 CONTINUE
C
904 FORMAT(*-,3X,*TIME = *,I4)
IF (IPCR(49).EQ.0) GO TO 100
Y(1,1) = Z(1,14)
Y(1,2) = G(43,1)
Y(1,3) = G(43,2)

```

```

Y(1,4) = G(43,3)
Y(1,5) = G(43,4) * 0.1
SUM = 0.0
DO 20 I=1,13
20 SUM = SUM + XM(1,2,I+1) + XM(2,2,I)
IF (SUM.NE.0.0) Y(1,6) = G(43,4) / SUM
IF (G(43,5).NE.0.0) Y(1,7) = G(43,4) / G(43,5)
C
DO 25 J=8,12
25 Y(1,J) = 0.0
C
DO 30 I=1,13
II = I + 1
III = I + 2
Y(1,8) = Y(1,8) + XM(1,1,II)
Y(1,9) = Y(1,9) + XM(1,1,II) * G(1,II) + XM(2,1,I) * G(1,I)
Y(1,10) = Y(1,10) + XM(1,1,II) * G(6,II) * G(8,II)
IF(III.NE.15) Y(1,11) = Y(1,11)+G(41,III) * G(4,III)
1 + G(42,III) * G(4,III)
IF(III.EQ.15) Y(1,11) = Y(1,11) + G(41,III) * G(4,III)
Y(1,12) = Y(1,12) + FLOAT(II) * XM(1,1,II) + FLOAT(I) * XM(2,1,I)
30 CONTINUE
C
IF (Y(1,8) .NE. 0.0) Y(1,8) = G(43,4) / Y(1,8)
IF (G(43,5)+XM(2,1,1).NE.0.0) Y(1,9)=Y(1,9) / (G(43,5)+XM(2,1,1))
IF (G(43,4).NE.0.0) Y(1,10) = Y(1,10) * 100.0 / G(43,4)
IF (G(43,3).NE.0.0) Y(1,11) = Y(1,11) * 10.0 / G(43,3)
IF (G(43,5)+XM(2,1,1).NE.0.0) Y(1,12)=Y(1,12)/(G(43,5)+XM(2,1,1))
Y(1,13) = G(43,6)
IF (G(43,6).NE.0.0) Y(1,14) = G(43,4) * 0.1 / G(43,6)
C
DO 40 J=1,15
IF (J.EQ.15) GO TO 35
IF (J.EQ.1) Y(2,J) = XM(2,1,1)
IF (J.GT.1.AND.J.LT.14) Y(2,J) = XM(2,1,J) + XM(1,1,J)
IF (J.EQ.14) Y(2,J) = XM(1,1,14)
35 Y(3,J) = G(14,J)
IF (J.GE.2.AND.J.LE.14) Y(4,J) = G(30,J)
IF (J.GE.1.AND.J.LE.13) Y(5,J) = G(32,J)
IF (J.GE.2.AND.J.LE.14) Y(6,J) = G(28,15-J)
IF (J.EQ.1) Y(7,J) = G(28,14)
IF (J.GE.2.AND.J.LE.13) Y(7,J) = G(31,J)
40 CONTINUE
C
IF (B(IZ14-1849).NE.0.0) Y(8,1) = G(43,1) / B(IZ14-1849)
IF (IZ14.NE.1978) GO TO 50
IF (B(99).NE.0.0) Y(8,2) = G(44,1) / B(99)
Y(8,3) = G(45,11)
Y(8,4) = G(45,12)
Y(8,5) = G(45,13)
Y(8,6) = G(45,14)
Y(8,7) = G(45,15)
50 Y(8,8) = G(43,1)
Y(8,9) = B(IZ14 - 1849)
C
IF (B(IZ14-1819).NE.0.0) Y(9,1) = G(43,2) / B(IZ14-1819)
IF (IZ14.NE.1978) GO TO 60
IF (B(99).NE.0.0) Y(9,2) = G(44,2) / B(99)
Y(9,3) = G(46,11)
Y(9,4) = G(46,12)
Y(9,5) = G(46,13)
Y(9,6) = G(46,14)
Y(9,7) = G(46,15)

```

```

60  Y(9,8) = G(43,2)
    Y(9,9) = B(IZ14 - 1819)
C
    IF (B(IZ14-1790).NE.0.0) Y(10,1) = G(43,3) / B(IZ14-1790)
    IF (IZ14.NE.1978) GO TO 70
    IF (B(99).NE.0.0) Y(10,2) = G(44,3) / B(99)
    Y(10,3) = G(47,11)
    Y(10,4) = G(47,12)
    Y(10,5) = G(47,13)
    Y(10,6) = G(47,14)
    Y(10,7) = G(47,15)
70  Y(10,8) = G(43,3)
    Y(10,9) = B(IZ14 - 1790)
C
    IF (B(IZ14-1760).NE.0.0) Y(11,1) = G(43,6) / B(IZ14-1760)
    IF (IZ14.NE.1978) GO TO 80
    IF (B(99).NE.0.0) Y(11,2) = G(44,4) / B(99)
    Y(11,3) = G(48,11)
    Y(11,4) = G(48,12)
    Y(11,5) = G(48,13)
    Y(11,6) = G(48,14)
    Y(11,7) = G(48,15)
80  Y(11,8) = G(43,6)
    Y(11,9) = B(IZ14 - 1760)
C
    DO 96 J=1,14
    IF (J.EQ.1) Y(12,J) = Y(2,J)
    IF (J.GT.1) Y(12,J) = Y(12,J-1) + Y(2,J)
96  CONTINUE
C
    WRITE(12,905) (I,I=1,15)
    WRITE(12,904) IZ14
C
    IF (B(340).NE.1.0) GO TO 100
C
    DO 97 I=1,48
97  WRITE(12,901) I,(G(I,J),J=1,15)
901  FORMAT(* G(*,I2,*, J) =*,15(F8.3))
C
100  CONTINUE
    WRITE(10,905) (I,I=1,15)
    WRITE(10,904) IZ14
    DO 105 I=1,12
105  WRITE(10,902) I,(Y(I,J),J=1,15)
902  FORMAT(* Y(*,I2,*, J) =*,15(F8.3))
    DO 110 I=1,2
110  WRITE(10,903) I,(X(I,J),J=1,15)
903  FORMAT(* X(*,I2,*, J) =*,15(F8.3))
C
    WRITE(11,906) Y(1,1),Y(8,8),Y(8,9),Y(9,8),Y(9,9),
    +Y(10,8),Y(10,9),Y(11,8),Y(11,9)
906  FORMAT(1X,F5.0,2X,8F7.2)
C
    RETURN
    END

```