

**THE ELECTRIC BALANCE TECHNIQUE FOR MEASURING
THE MASS AND CHARGE OF CLAY PARTICLES**

by

EUGENE RAYMOND PERRIER

A THESIS

submitted to

OREGON STATE COLLEGE

in partial fulfillment of
the requirements for the
degree of

MASTER OF SCIENCE

June 1957

APPROVED:



Associate Professor of Soils
In Charge of Major



Head of Soils Department



Chairman of School Graduate Committee



Dean of Graduate School

Date thesis is presented May 8, 1957

Typed by Joann Brady

TABLE OF CONTENTS

| | Page |
|---|------|
| INTRODUCTION | 1 |
| OBJECTIVES OF STUDY | 3 |
| MILLIKAN OIL DROP APPARATUS AND PROCEDURE | 4 |
| CLAY PARTICLE CONSIDERATIONS | 10 |
| EXPERIMENTAL PROCEDURE | 18 |
| RESULTS AND DISCUSSION | 22 |
| CONCLUSIONS | 30 |
| BIBLIOGRAPHY | 31 |

LIST OF TABLES

| | Page |
|--|------|
| 1. An example of the calculations of the mass by the electric balance technique and the mass involving Stokes' law | 21 |
| 2. Experimental results | 23 |

LIST OF FIGURES

| | Page |
|--|------|
| 1. Schematic diagram of the Millikan oil drop apparatus. | 5 |
| 2. Electron micrograph of a kaolinite clay particle showing the hexagonal shape. | 15 |
| 3. Electron micrograph showing halloysite that is present in the standard sample used. | 16 |
| 4. Electron micrograph of kaolinite particles showing the result of shadow casting (angle = $19^{\circ} 51'$) and showing the presence of aggregated particles. | 17 |
| 5. A plot of the mass as measured by the electric balance technique versus the mass as calculated using Stokes' law. | 25 |
| 6. A plot of the mass of a given particle as measured by the electric balance technique versus the initial number of charges on the particle. | 26 |

ACKNOWLEDGEMENT

The author wishes to express his sincere appreciation to Dr. Daniel D. Evans for his guidance and council in the preparation of this thesis. A special word of thanks is extended to Dr. Albert W. Marsh without whose assistance this study would not have been performed.

A special acknowledgement is accorded Dr. Moyle E. Harward for his helpful criticisms and suggestions in the preparation of the manuscript.

A special acknowledgement is also accorded to Dr. James J. Brady for his helpful suggestions and for the use of his laboratory facilities and equipment.

The author wishes to express his thanks to John G. Skinner through whose efforts the electron micrographs were made available.

THE ELECTRIC BALANCE TECHNIQUE FOR MEASURING THE MASS AND CHARGE OF CLAY PARTICLES

INTRODUCTION

The mass and charge of clay particles determine to a large extent the chemical and physical behavior of the particles. In soil, the amount of clay as well as the size and electric charge of the clay particles influences the behavior and productivity of the soil. Therefore, the measurement of these two properties is of primary importance to chemists and physicists whose interests are in examining the basic properties of clays, other colloids and soils.

The mass of clay particles is usually calculated from the density of the particles and the volume of the particles. The volume is obtained from an effective radius determined by the use of Stokes' law which relates the velocity of fall of a sphere through a fluid to the radius of the sphere. The effective radius of a clay particle is the radius of a sphere that would have the same velocity of fall as that of the clay particle. Since the clay particles are not normally spherical in shape, the effective radius may not describe accurately the dimensions of the particles. Also, there are several assumptions made in the derivation of Stokes' law which may not be valid for the fall of soil particles. The magnitude of the error included in using Stokes' law has not been previously evaluated.

The electric charge of clay particles is normally negative and is believed to be due to broken bonds and isomorphous substitution. The electric charge is assumed to be balanced by exchangeable ions

adsorbed to the particles surface. The magnitude of the charge is related to the cation exchange capacity of most clay particles.

The electrical balance technique, utilizing the Millikan oil drop apparatus, lends itself to the simultaneous measurement in air of the electric charge and mass of a particle. The mass may be determined with or without the use of Stokes' law. The electric charge measured by the electric balance technique is due to bonds unsatisfied by exchangeable ions and not the same as that which is related to the cation exchange capacity which is due to the clay particle itself.

OBJECTIVES OF STUDY

1. To determine the electric charge on dry kaolinitic clay particles in air.
2. To determine the mass of dry kaolinitic clay particles by the electric balance technique and by the use of Stokes' law.
3. To determine the error involved in determining the mass of particles due to the assumptions made in the derivation of Stokes' law.

MILLIKAN OIL DROP APPARATUS AND PROCEDURE

Millikan (8, pp. 45-114) devised the apparatus as shown in figure 1 and was able to determine the charge of an electron. By his procedure he was able to determine the total charge that is given to an oil droplet by blowing an oil spray into the chamber C with the aid of an atomizer. Minute droplets, most of them having diameters of about one micron, fall slowly in the chamber and a few find their way through the pinhole p in the middle of the circular brass plate M. The oil droplets which enter through p are illuminated by a light beam which enters at c. The droplets appear as bright stars on a black background as the scattered light is observed. These oil droplets are found, in general, to be strongly charged by the frictional process involved in atomizing the oil. A difference of potential, ranging from 0 to 10,000 volts, is placed across the two plates, M and N causing an induced electric field. When the electric field is induced in the proper direction and exceeds a certain magnitude the droplets are pulled toward M. One droplet is selected for study and just before the drop strikes M the plates are short-circuited and the drop is allowed to fall under gravity until it is close to N, then the direction of motion is again reversed by inducing the electric field. The droplet may be easily controlled by varying the voltage and balanced against the force of gravity.

The total charge on the droplet is changed by short-circuiting

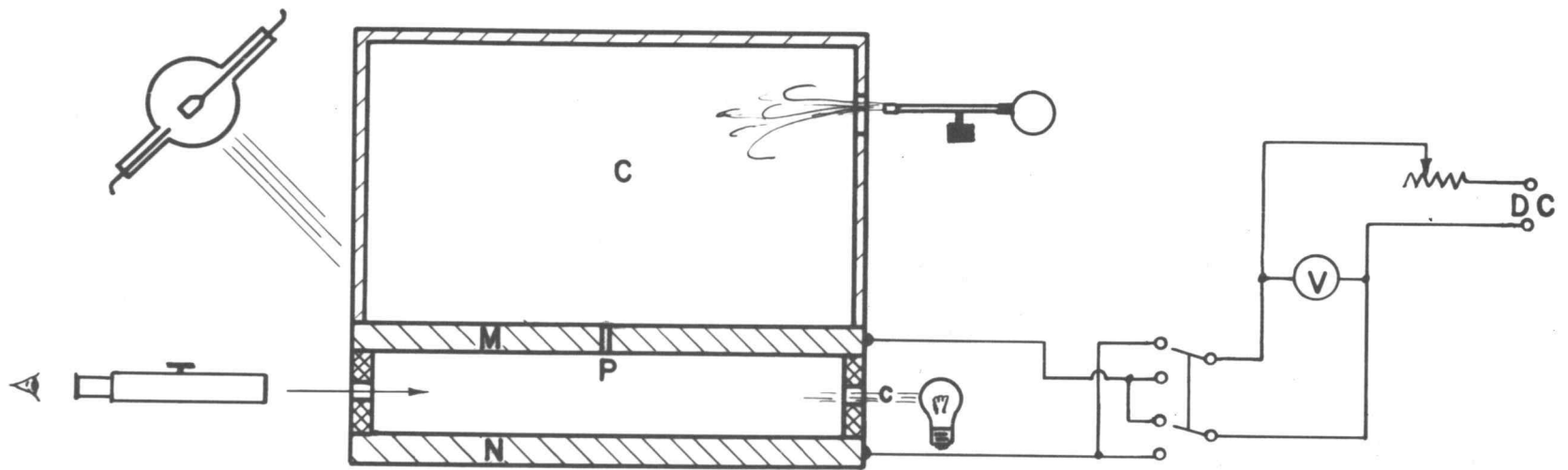

Figure 1. Schematic diagram of the Millikan oil drop apparatus.

the plates and allowing x-rays to pass between the plates. The x-rays act as an ionizing agent to produce uniform ionization in the gas between the plates. In this way more or less charge may be placed upon the drop, the theory of which will be discussed later. After the charge on a drop has been changed the drop is again balanced against the force of gravity and the voltage recorded. The procedure is repeated several times using the same particle.

In order to evaluate the magnitude of the number of charges, n , at the various voltages recorded, it is necessary to arrange the voltages in descending order. If ΔV^{-1} is the reciprocal of the voltage change and Δn is the change in charge, then

$$\Delta V^{-1} \sim \Delta n \quad (1)$$

When $\Delta n = 1$, then ΔV^{-1} is at the lowest difference of potential measurable for a unit charge on the particular droplet being studied. It is necessary to make several voltage changes to establish $\Delta n = 1$. The procedure will be outlined in greater detail and an example given.

Using the data obtained for calculating the electric charge on an oil droplet it is possible to calculate the mass of the oil droplet. Millikan states, "This device is simply an electrical balance in place of a mechanical one, and it will weigh accurately and easily to one ten-billionth of a milligram." In the derivation of equation (6) below, which is the equation used for calculating

the mass, the force of gravity is balanced against the force due to the electric field. The force of gravity, F , is given by Newton's second law,

$$F = mg, \quad (2)$$

where m is the mass and g is the acceleration due to gravity. The force due to an electric field is given by the equation

$$F = nEe, \quad (3)$$

where n is the number of charges, E is the electric field strength and e is the charge of an electron. Since the two forces are equal when the particle is at rest, equations (2) and (3) may be combined as

$$nEe = mg \quad (4)$$

Also,

$$E = \frac{V}{d} \quad (5)$$

where V is the difference of potential and d is the distance between the plates (M and N). Therefore, substituting (5) into (4) and solving for the mass we have

$$m = \frac{neV}{gd} \quad (6)$$

This measurement of mass does not involve the shape of the particle, the type of medium or the assumptions involved in the derivation of Stokes' law. It is only necessary to determine the number of

charges and to measure the difference of potential necessary to overcome the force due to gravity.

To calculate the mass of the droplet using Stokes' law, the derivation of which will be described in detail later, it is necessary to measure the velocity. This is accomplished by timing the fall of the particle through a distance fixed by two cross-hairs that are mounted in the telescope that can be seen in figure 1. To calculate the mass we have

$$m = V\rho = \frac{4}{3} \pi r^3 \rho. \quad (7)$$

where V is the volume of the droplet, r is the radius as determined from Stokes' law and ρ is the density of the droplet.

As previously stated, Millikan changed the total charge on the droplet by allowing x-rays to pass between the plates, which means that either free electrons or ions are being attached or removed from the oil droplet under observation. The x-rays ionize the air by two principal processes the most important of which is the photoelectric effect. Possibly some ionization is due to the Compton effect.

As stated by Lapp and Andrews (5, pp. 114-118) when an x-ray quantum or photon collides with an atom, it may impinge upon an orbital electron and transfer all of the energy of the photon to the atom by ejecting an electron from the atom. If the incident photon carried more energy than that necessary to remove the orbital electron from the atom, it imparts to the electron its

additional energy in the form of kinetic energy. This process is known as the photoelectric effect and obeys the Einstein photoelectric equation,

$$E = h\nu = \phi + E_k \quad (8)$$

where h is plank's constant, ν is the frequency of the impinging photon, and the product of the two is the total energy E . ϕ is the energy required to remove the electron from its atom and E_k is the kinetic energy of the ejected electron. Electrons thus ejected from atoms are called photoelectrons, and the remaining atom in the air becomes an ion.

In explanation of the interaction between electromagnetic radiation and a particular electron, Compton made the assumption that this process is an elastic collision between the photon and the electron. If a photon is properly incident upon a loosely bound electron of an atom it may itself be scattered by the electron and suffer a loss in energy. The electron takes up the difference in energy between the incident and scattered photon and is ejected with this recoil energy. Electrons thus ejected from atoms are called Compton electrons or Compton recoil electrons, and the remaining atom in the air becomes an ion.

CLAY PARTICLE CONSIDERATIONS

In the mathematical derivation of Stokes' law, Sears and Zemansky (9, p. 258) have stated that when a viscous fluid flows past a sphere with a streamline flow or when a sphere moves through a viscous fluid at rest, a resisting force is exerted on the sphere. A force is experienced by a body of any shape but only for a sphere is the expression for force readily calculable. First, the derivation of the equation for a sphere falling through a viscous fluid will be considered. The resisting force is given by

$$F = 6\pi\eta r v, \quad (9)$$

where η is the viscosity of the fluid, r is the radius of the sphere, and v is the relative velocity of the sphere to the fluid. If the sphere is released from rest where $v = 0$, the viscous force at the start is zero. The other forces on the sphere are gravity and bouyancy. If ρ is the density of the sphere and ρ_0 the density of the fluid the mathematical expression for the two forces are

$$\text{gravity force} = mg = \frac{4}{3}\pi r^3 \rho g, \quad (10)$$

and

$$\text{bouyancy force} = \frac{4}{3}\pi r^3 \rho_0 g. \quad (11)$$

Since there is a net downward force on the sphere, it is accelerated and as a result of the acceleration, the sphere acquires a downward velocity and therefore experiences a retarding force.

As the velocity increases, the retarding force also increases in direct proportion, and eventually a velocity is reached such that the downward force and the retarding forces are equal, that is

$$\text{gravity force} = \text{resisting force} + \text{bouyance force} \quad (12)$$

The sphere then ceases to accelerate and moves with a constant velocity called its terminal velocity. This velocity can be found by setting the downward force equal to the retarding forces.

$$\frac{4}{3}\pi r^3 (\rho - \rho_0) g = 6\pi\eta r v, \quad (13)$$

or

$$v = \frac{2}{9} r^2 g (\rho - \rho_0) / \eta . \quad (14)$$

This relation was first deduced by Sir George Stokes in 1845 and is called Stokes' law.

In the above derivation of Stokes' law, which gives the velocity of fall of a spherical particle under the influence of gravity, the following five assumptions are made:

1. That the inhomogeneities in the medium are small in comparison with the size of the sphere.
2. That the sphere falls as it would in a medium of unlimited extent.
3. That the sphere is smooth and rigid.
4. That there is no slipping of the medium over the surface of the sphere.

5. That the velocity with which the sphere is moving is small so that the resistance to the motion is all due to the viscosity of the medium and not at all due to the inertia of such portion of the media as is being pushed forward by the motion of the sphere through it.

The assumptions are generally considered valid for spheres, within a certain size range depending upon the fluid used. Clay particles are not spherical but the assumptions are generally considered valid. The assumptions will be discussed as they apply to clay particles falling in air.

Aside from the fact that clay particles are not spherical, assumption 1 does not hold throughout the entire size range. The assumption is probably valid for the larger particles but may be in error for the smaller particles. Millikan (8, pp. 98-102) observed that as the size of the oil drop used in the experiments diminished the velocity in air increased over that predicted by equation (14). He stated that this increase in velocity was due to the diminishing radius of the drop beginning to compare with the mean size of the holes in the air. Millikan used the "mean free path" of the gas molecule to correct equation (14) which reads as follows:

$$v = \frac{2}{9} g r^2 (\rho - \rho_0) / \eta \left(1 - \frac{b}{pr} \right), \quad (15)$$

where b is a constant determined by graphical analysis and equal to 1.67×10^{-4} for oil droplets and p is the pressure of the air in

centimeters of mercury. This correction factor is negligible for particles falling in a liquid since the mean free path of liquid molecules is much less than for gas molecules; but in this study the correction factor was considered.

Assumption 2 is considered valid if the concentration of particles is not too great. Assumption 3 is generally considered valid and is the assumption to be evaluated in this study. Assumption 4 is considered valid since air is adsorbed to the particles. Assumption 5 is probably not too important even with clay particles; because of their relatively small size no turbulence is expected.

Oil droplets are nearly spheres while clay colloids are not spherical in shape. Grim (4, pp. 46-49) states that kaolinite, which is the clay type to be used in this study, is a well-crystallized, six-sided flake, frequently with a prominent elongation in one direction. Electron micrographs as shown in figures 2, 3, and 4 demonstrate the clay type used in this experiment. It can be noted that the particles appear as aggregates as well as individual particles.

Marshall (7, p. 68) states that the particle size distribution from a sample of standard kaolinite to be about, (total material

$< 2 \mu = 100\%$)

| | | | | |
|---------------|------------------|--------------------|---------------------|---------------|
| 2 - 0.5 μ | 0.5 - 0.25 μ | 0.25 - 0.125 μ | 0.125 - 0.062 μ | < 0.062 μ |
| 46% | 42% | 5% | 3% | 3% |

This size distribution corresponds to the sizes examined in this study as most of the particles are within the 2 - 0.25 micron range.

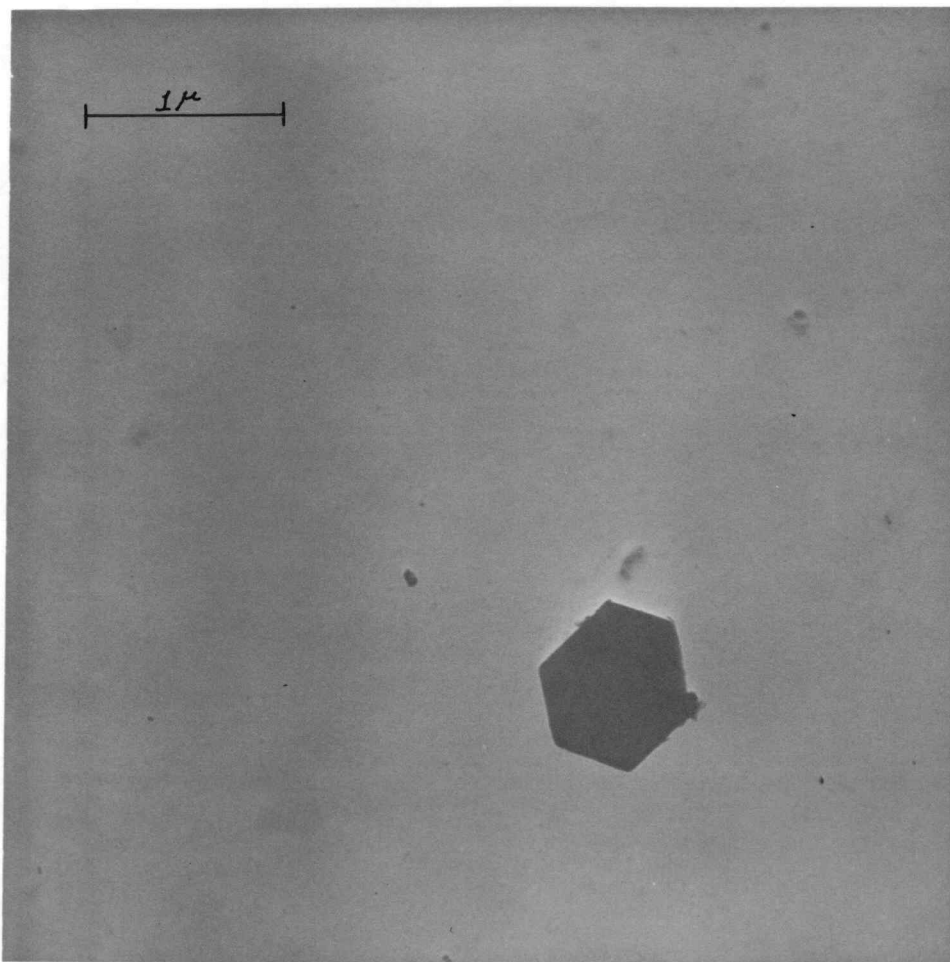

Figure 2. Electron micrograph of a kaolinite clay particle showing the hexagonal shape.

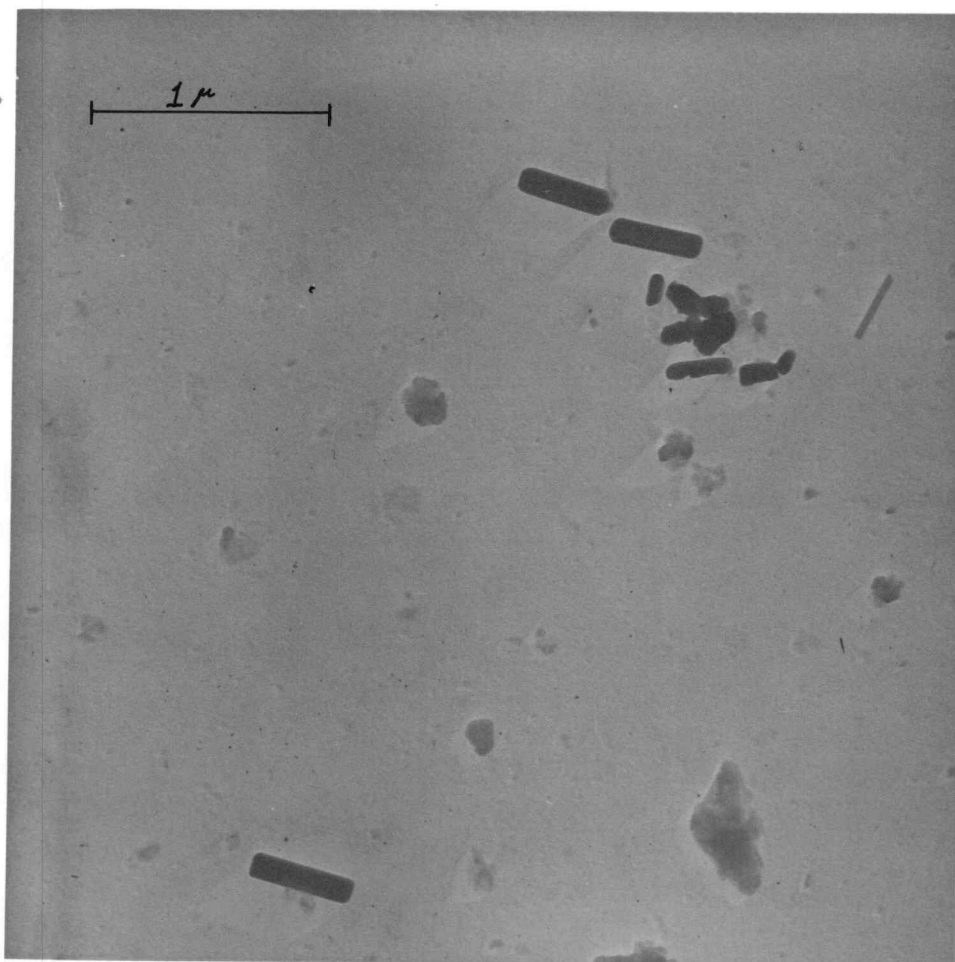

Figure 3. Electron micrograph showing halloysite that is present in the standard sample used.

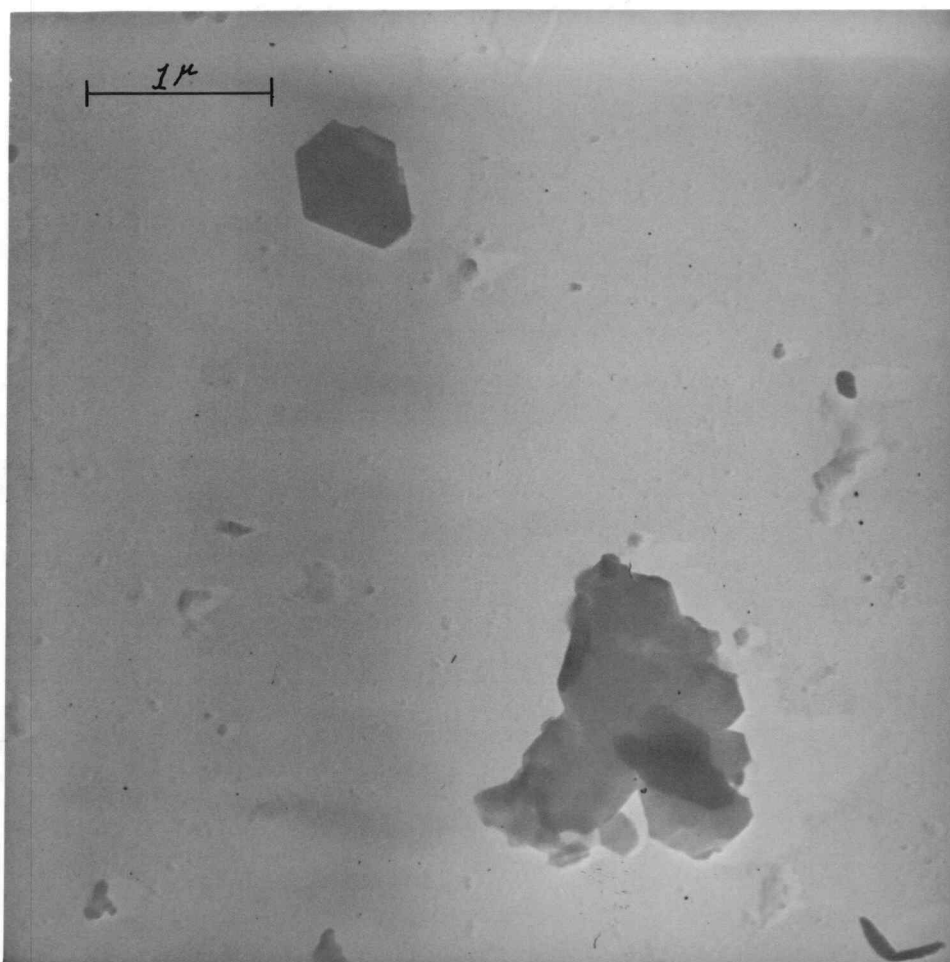

Figure 4. Electron micrograph of kaolinite particles showing the result of shadow casting (angle $19^{\circ} 51'$) and showing the presence of aggregated particles.

EXPERIMENTAL PROCEDURE

The kaolinite clay used throughout this experiment was a standard Georgian kaolinite, number 2023, obtained from the Georgian Kaolin Company at Dry Branch, Georgia. It can be noted from the electron micrograph, figure 3, that the sample apparently contained some Halloysite which was estimated to be 7% of the sample used. The Halloysite can be seen in the shape of rods.

The particles were prepared for study by making a liter solution of 10% Kaolinite and 2% sodium chloride and was allowed to stand for at least 8 hours. Whereupon a portion of the clay remaining in suspension was decanted off, filtered, rinsed thoroughly with distilled water and dried in an oven at 105 degrees centigrade. It was then ground in a mortar and placed in a dust proof container.

The apparatus which was used in this study was similar to that shown in figure 1. The distance between the plates M and N is 0.8 centimeters. The voltage varied from 0 to 3000 volts which was adequate for the size range studied. The voltage was measured by a previously calibrated wall type ballistic galvanometer. The clay was placed on a 300-mesh brass sieve which was electrically grounded and the particles were shaken over plate M, and a few found their way through pinhole p. The rest of the procedure was as described previously for the Millikan oil drop apparatus.

The results of each step of the procedure used for calculating

the mass and charge of kaolinitic particles is given in table 1. The data are for one particle and is presented as an example. The voltages are given in column one as they were obtained, that is, the successive changes in the voltage due to the changes in the charge by x-rays. The second column shows the voltages as they must be arranged in descending order. The third column gives the reciprocal of the voltages in column two. The fourth column gives the successive changes in the voltage due to the gain in electrons. The fifth column corresponds to the gain of one or several distinct electrons.

It can be seen from column four that 2.2×10^{-5} is the lowest difference of potential measured, therefore, this difference of potential corresponds to the change of one electron. Then each reciprocal of the change in voltage, ΔV^{-1} , is divided by 2.2×10^{-5} to obtain the change in the number of charges, Δn .

The sixth column represents the successive values of the total charge carried by the particle. This column is determined by dividing the value of ΔV^{-1} that corresponds to $\Delta n = 1$ into the values of column 3. The seventh column gives the mass as calculated by the use of equation (6). Column eight gives the time the particle took to fall 0.2 centimeters in air. The last column, nine, gives the mass as calculated by equation (7) which involves Stokes' law plus the relationship of volume and density. The density of Kaolinitic clay was taken from Grim (4, p. 313) who stated the density to be about 2.65 grams per cubic centimeter.

The standard deviation for the mass as calculated by each method is presented at the bottom of the table.

Table 1. An example of the calculations of the mass by the electric balance technique and the mass involving Stokes' law.

| 1 Recorded voltages | 2 Volts | 3 v^{-1} | Electric Balance | | | 6 n | 7 Mass (gms x 10 ¹¹) | Stokes' Law | |
|---------------------------|------------|---------------|----------------------|-----------------|-------------------------|--------|--|--|--|
| | | | 4 Δv^{-1} | 5 Δn | 8 Time (secs) | | | 9 Mass (gms x 10 ¹¹) | |
| 125.8 | 728.1 | 0.001373 | 0.000039 | 2 | 62 | 9.213 | 1.74 | 8.045 | |
| 587.5 | 708.5 | 0.001412 | 0.000022 | 1 | 63 | 9.109 | 1.70 | 8.331 | |
| 218.8 | 697.5 | 0.001434 | 0.000021 | 1 | 64 | 9.110 | 1.75 | 7.977 | |
| 541.2 | 689.2 | 0.001455 | 0.000045 | 2 | 65 | 9.142 | 1.73 | 8.115 | |
| 456.1 | 671.2 | 0.001490 | 0.000212 | 10 | 67 | 9.178 | 1.66 | 8.634 | |
| 335.4 | 587.5 | 0.001702 | 0.000124 | 5 | 77 | 9.232 | 1.69 | 8.405 | |
| 697.5 | 547.7 | 0.001826 | 0.000022 | 1 | 82 | 9.166 | 1.67 | 8.557 | |
| 397.9 | 541.2 | 0.001848 | 0.000194 | 11 | 83 | 9.167 | 1.60 | 9.124 | |
| 467.2 | 489.8 | 0.002042 | 0.000051 | 2 | 92 | 9.196 | 1.73 | 8.115 | |
| 541.2 | 477.7 | 0.002093 | 0.000047 | 2 | 94 | 9.164 | 1.74 | 8.045 | |
| 290.1 | 467.2 | 0.002140 | 0.000052 | 2 | 96 | 9.153 | 1.73 | 8.115 | |
| 708.5 | 456.1 | 0.002192 | 0.000321 | 14 | 99 | 9.215 | 1.80 | 7.646 | |
| 467.2 | 397.9 | 0.002513 | 0.000278 | 13 | 113 | 9.176 | 1.71 | 8.258 | |
| 728.1 | 358.3 | 0.002791 | 0.000191 | 8 | 126 | 9.213 | 1.72 | 8.186 | |
| 280.3 | 335.4 | 0.002982 | 0.000465 | 21 | 134 | 9.172 | 1.64 | 8.791 | |
| 456.1 | 290.1 | 0.003447 | 0.000121 | 7 | 155 | 9.176 | Ave. | 8.254 | |
| 697.5 | 280.3 | 0.003568 | 0.001002 | 45 | 161 | 9.210 | Std. Dev. = \pm 0.367 | | |
| 489.8 | 218.8 | 0.004570 | 0.001045 | 147 | 206 | 2.198 | | | |
| 587.5 | 178.1 | 0.005615 | 0.002334 | 5 | 353 | 9.196 | | | |
| 689.2 | 125.8 | 0.007949 | | | 358 | 9.191 | | | |
| 178.1 | | | | | Ave. | 9.179 | | | |
| 547.7 | | | | | Std. Dev. = \pm 0.033 | | | | |
| 587.2 | | | | | | | | | |
| 477.7 | | | | | | | | | |
| 358.3 | | | | | | | | | |
| 671.2 | | | | | | | | | |

RESULTS AND DISCUSSION

The described procedure has been used to determine the mass, by the two methods, and the electric charge on a number of kaolinitic clay particles. The results for 19 particles are shown in table 2. The initial charge on each particle is given in column 2. The range of charges is from 14 to 369. The masses as determined by the electric balance technique and by calculations involving Stokes' law are presented in column 3 and 5 respectively. Each figure is a mean of several determinations, an average of 20 voltage changes for the electrical balance technique and 15 times of fall for the procedure using Stokes' law. The standard deviation for each mean is given with the mass of each particle. It can be noted that the electric balance technique weighs the particles with an accuracy of about 3 significant figures and in the region of 10^{-13} gram, whereas the mass measurements involving Stokes' law give an accuracy of about 2 significant figures and in the region of 10^{-12} gram. The variance of the electric balance technique is probably due to the difficulty in detecting whether or not the particle is in balance at the time of measurement and there is a slight error involved in reading the galvanometer. The variance in the Stokes' law calculations is probably due to the shape of the particles plus a slight error in operating the stop watch.

Column 7 of table 2 gives the level of significance of the

Table 2. Experimental results (n = number of charges initially measured, M_e = mass as determined by the electric balance technique, S_e = standard deviation of M_e , M_s = mass as determined by the use of Stokes' law, S_s = standard deviation of M_s , per cent difference = $100 \times (M_e - M_s) / M_e$)
 Column 10 describes whether or not the particle deviated from a vertical drop.)

| 1 Particle No. | 2 n | 3 M_e (gms x 10^{11}) | 4 S_e (gms x 10^{11}) | 5 Mass x 10^{11} gms M_s | 6 S_s (gms x 10^{11}) | 7 Sign M_e vs M_s | 8 Per cent difference | 9 Scintillation ² | 10 Vertical- drop |
|----------------------|----------|----------------------------------|----------------------------------|------------------------------------|----------------------------------|-----------------------------|-----------------------------|---------------------------------|-------------------------|
| 1 | 165 | 9.653 | 0.043 | 8.329 | 0.417 | ** | 13.71 | 3 | No |
| 2 | 38 | 4.165 | 0.039 | 2.669 | 0.109 | ** | 35.92 | 2 | No |
| 3 | 16 | 4.663 | 0.049 | 3.627 | 0.121 | * | 22.22 | 3 | Yes |
| 4 | 28 | 7.878 | 0.034 | 7.280 | 0.259 | ** | 7.59 | 2 | Yes |
| 5 | 358 | 9.179 | 0.033 | 8.254 | 0.367 | ** | 10.08 | 3 | No |
| 6 | 62 | 10.40 | 0.040 | 10.15 | 0.043 | NS | 2.40 | 2 | Yes |
| 7 | 70 | 4.446 | 0.024 | 4.285 | 0.461 | * | 3.62 | 2 | Yes |
| 8 | 75 | 6.418 | 0.036 | 1.265 | 0.060 | ** | 80.54 | 3 | No |
| 9 | 108 | 6.059 | 0.056 | 5.983 | 0.290 | NS | 1.25 | 2 | Yes |
| 10 | 74 | 6.574 | 0.033 | 5.127 | 0.240 | ** | 22.01 | 1 | Yes |
| 11 | 108 | 4.289 | 0.001 | 4.141 | 0.319 | ** | 3.45 | 4 | No |
| 12 | 36 | 2.726 | 0.056 | 2.618 | 0.062 | ** | 3.96 | 3 | Yes |
| 13 | 369 | 11.86 | 0.041 | 11.70 | 0.638 | NS | 1.35 | 2 | Yes |
| 14 | 26 | 0.5531 | 0.016 | 0.5251 | 0.012 | NS | 5.06 | 3 | Yes |
| 15 | 14 | 2.000 | 0.018 | 1.807 | 0.207 | ** | 9.65 | 2 | Yes |
| 16 | 334 | 12.00 | 0.020 | 11.70 | 0.520 | NS | 2.50 | 1 | No |
| 17 | 40 | 10.20 | 0.172 | 10.25 | 0.604 | NS | 0.05 | 1 | Yes |
| 18 | 98 | 10.20 | 0.002 | 9.460 | 0.710 | * | 7.30 | 3 | Yes |
| 19 | 168 | 12.79 | 0.021 | 12.81 | 1.020 | ** | 0.02 | 2 | No |

Amount of scintillation

- 1 - Small
- 2 - Average
- 3 - High
- 4 - Extreme

Level of Significant Difference

- * Significant at 5%
- ** Significant at 5% and 1%
- NS Not Significant

difference between the two mass determinations. Column 8 presents the percentage difference between the two masses. The amount of scintillation and deviation from a vertical drop was noted and is recorded in columns 9 and 10.

Figure 5 is a graph showing mass measured by the electric balance technique plotted against the mass calculated using Stokes' law. It can be seen that in nearly all cases the mass as obtained by the use of Stokes' law is less than the mass as obtained by the electric balance technique. The direction of difference is due to the plate shape nature of clay particles which offers more resistance to fall than the same mass in the form of a sphere. This indicates that assumption 3 of Stokes' law (see page 11) does not hold for all kaolinitic clay particles. It can be seen from figure 5 that no definite pattern exists which would suggest a possible correction factor to be used for Stokes' law. The random arrangement of the comparative values for mass is reasonable when the irregular shape of the particles as noted in figures 2, 3, and 4 is taken into account.

Figure 6 shows that there is the possibility of a relationship between the mass of the particles as calculated by the electric balance technique and the number of initial charges on the particles. No statistical analysis was made on these data due to the degree of scatter. This is also complicated by the fact that it is not known whether the measurement was made on a single particle or an aggregate.

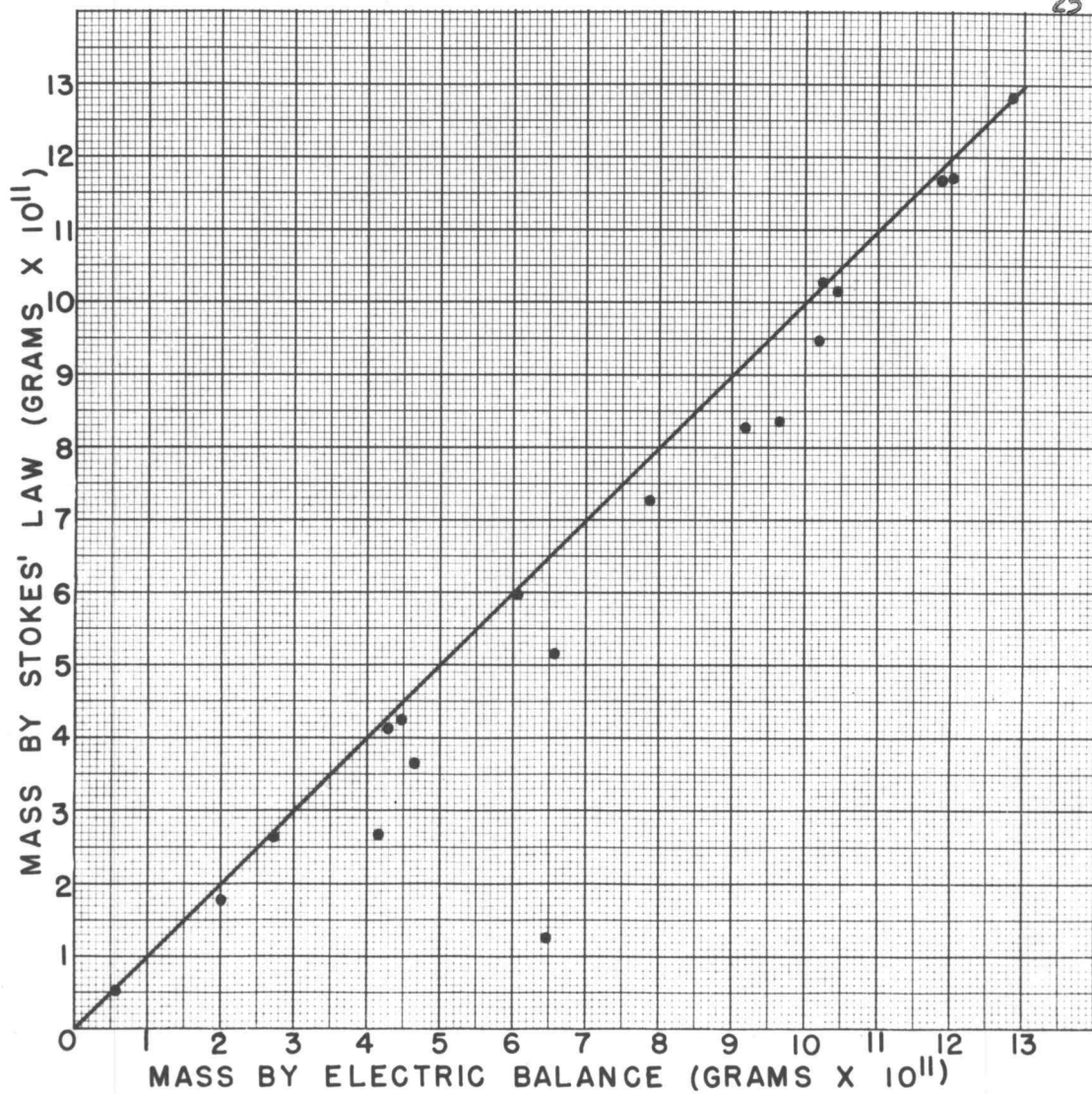

Figure 5. A plot of the mass as measured by the electric balance technique versus the mass as calculated using Stokes' law. (The line has the slope of unity.)

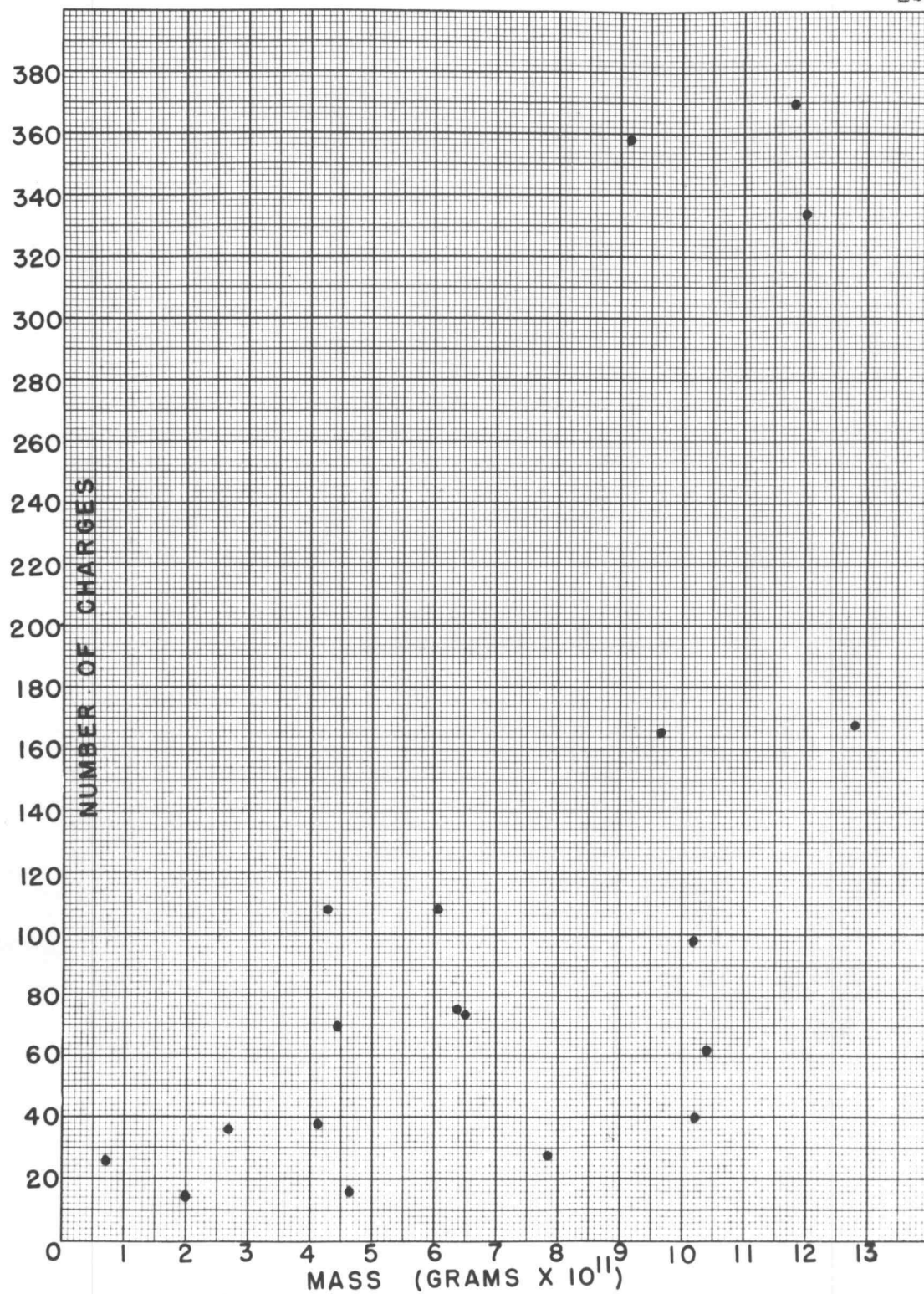

Figure 6. A plot of the mass of a given particle as measured by the electric balance technique versus the initial number of charges on the particle.

It has been generally assumed that exchangeable cations satisfy all of the negative charges on clay particles and that no external charges remain. This study indicates this is not true, although the total number of charges are relatively small compared to the overall charge available for cation exchange in liquid. As a comparison of the magnitudes of both charges an example is given.

We will assume that we have a kaolinitic clay particle whose mass when measured by the electric balance technique is 6.00×10^{-11} gram and it requires initially 500 volts to balance the particle against the force of gravity. Lyon, Buckman and Brady (6, p. 101) have stated that the average cation exchange capacity for kaolinite is about 8 milliequivalents per 100 grams. Therefore, when 8 me/100 gms. is multiplied by Avogadro's number and divided by 10^5 we have remaining 4.82×10^{19} charges per gram of kaolinitic clay. As the particle weighs 6.00×10^{-11} gram and when multiplied by 4.82×10^{19} charges per gram we have estimated that the particle when in solution should have 2.89×10^9 charges available for cation exchange.

As previously stated this particle required 500 volts to balance against gravity. The following relationship from equation 6 is used to calculate the number of charges on the particle,

$$n = \frac{mgd_1}{eV} \quad (16)$$

In this case the total number of charges in an air-dry atmosphere is 59. This demonstrated that in air-dry conditions some charge does exist but the magnitude of the charge is small compared to the charge associated with the cation exchange capacity as measured in water.

During the process of measurement the air pressure was recorded from a wall type mercury barometer. This information was necessary to calculate the mass using the correction factor developed by Millikan and expressed in the form of equation 15. The calculations made on the particles did not change the masses as calculated from the non-corrected form of Stokes' law, equation 14, and, therefore, this information was not included due to the small effect of the air pressure on the size of the particles measured.

While observing a kaolinitic clay particle in the Millikan apparatus it can be noted that the particle twinkles and moves in and out of focus of the telescope. The particle appears to roll and otherwise be in constant motion during the period of measurement. The motion of these small particles is commonly referred to as Brownian motion in honor of Robert Brown who first made mention of this movement in 1827. Semat (10, p. 28) states that Brownian motion is based on the assumption that the particles in suspension are continually bombarded by the molecules of the fluid and that this bombardment produces an unbalanced force which accelerates the particle. Dallavalle (2, p. 164) states that when the particles are suspended in a gas they follow the relationship

$$PV = (n/N) RT, \quad (17)$$

where P is the pressure, V the volume, n the number of particles into which one gram-molecule of the disperse phase is disintegrated, N the number of gas molecules per gram-molecule of a gas (Avogadro's number), R the gas constant and T the absolute temperature.

Gibbs (3, p. 46) has given the following essential information with regard to particles in Brownian motion:

1. the particle moves with uniform velocity;
2. smaller particles move more rapidly than larger ones;
3. particles in high concentration move more rapidly than those in dilute concentrations;
4. particles move more rapidly through media of lower viscosity;
5. for constant viscosity the amplitude of the motion is directly proportional to the absolute temperature;
6. due to gravity, particles gradually arrange themselves so that their concentration is greatest at the lowest layer.

Although Brownian movement can be easily detected by the use of Millikan's apparatus the extent and magnitude was not determined.

CONCLUSIONS

The following conclusions may be drawn from this study:

1. The assumption made in the derivation of Stokes' law, that the sphere is smooth and rigid, is not valid for kaolinitic clay particles.
2. Stokes' law gives lower values for the calculation of the mass than those values measured by the electric balance technique.
3. The electric balance technique measures the mass of kaolinitic clay particles with much less error involved than the method utilizing Stokes' law.
4. There is an electric charge present on sodium saturated kaolinitic clay particles and in air is readily determinable. For the particles measured, the number of charges ranged from 14 to 369.
5. There is a relationship indicated between the total number of electrical charges present and the mass of kaolinitic clay particles.

BIBLIOGRAPHY

1. Bever, L. D. Soil physics. New York, Wiley, 1956. 489 p.
2. Dallavalle, J. M. Micromeritics. New York, Pitman, 1948. 555 p.
3. Gibbs, W. E. Clouds and smokes. Philadelphia, Blakiston, 1924.
240 p.
4. Grim, R. E. Clay mineralogy. New York, McGraw-Hill, 1953.
384 p.
5. Lapp, R. E. and H. L. Andrews. Nuclear radiation physics. New Jersey, Prentice-Hall, 1956. 532 p.
6. Lyon, T. L., H. O. Buckman, and N. C. Brady. The nature and properties of soils. New York, MacMillan, 1953. 591 p.
7. Marshall, C. E. The colloid chemistry of the silicate minerals. New York, Academic, 1949. 195 p.
8. Millikan, R. A. Electrons (+ or -), protons, photons, neutrons, mesatrons, and cosmic rays. Chicago, University of Chicago, 1947. 642 p.
9. Sears, F. W. and M. W. Zemansky. College physics. Cambridge, Massachusetts, Addison-Wesley, 1955. 912 p.
10. Semat, H. Introduction to atomic physics. New York, Rinehart, 1946. 412 p.