

An Abstract of the Thesis of

No-Soo Kim for the degree of Doctor of Philosophy in Chemistry
presented on June 8, 1992.

Title: Approaches to the Synthesis of Trichothecenes

Abstract approved: Redacted for Privacy

U
Dr. James D. White

Trichothecenes are secondary fungal metabolites which have potential medicinal importance. In this study, a novel approach to the synthesis of these sesquiterpenoids is presented.

A B-A-C route was investigated in which the C ring was constructed using a [2+2] photoaddition reaction between acetylene and an AB ring synthon, 6-carbomethoxy-9,9-diethoxy-5-oxo-8-(2'-trimethylsilyl)ethoxy-methoxy-2-oxabicyclo[2.2.0]deca-3-ene (**111**).

Ring expansion of photoadducts to afford the trichothecene skeleton was attempted using several methodologies. In one attempt, *cis-anti-cis*-8-carbomethoxy-11,11-diethoxy-7 β -hydroxy-7 α -methyl-10-[2'-(trimethylsilyl)-ethoxy]methoxy-2-oxatricyclo[6.4.0.0^{3,6}]dodec-4-ene (**137**) was treated with formic acid under typical solvolysis conditions. This reaction did not lead to formation of the desired carbon skeleton.

In an alternative approach, *cis-anti-cis*-8-carbomethoxy-11,11-ethylenedioxy-6-methyl-7-oxo-2-oxatricyclo[6.4.0.0^{3,6}]docec-4-ene (**176**) was subjected to *p*-toluenesulfonic acid in refluxing benzene in a variation of the Cargill reaction. This reaction yielded lactone **178**, processing the apotrithothecen skeleton.

Approaches to the Synthesis of Trichothecenes

by

No-Soo Kim

A Thesis
submitted to
Oregon State University

in partial fulfillment of
the requirements for the degree of
Doctor of Philosophy

Completed June 8, 1992
Commencement June 1993

APPROVED:

Redacted for Privacy

Professor of Chemistry

Redacted for Privacy

Chairman of Department of Chemistry

Redacted for Privacy

Dean of Graduate School

Date thesis is presented June 8, 1992

Typed by No-Soo for No-Soo Kim

Acknowledgements

I would like to thank professor James D. White for his help and guidance throughout my graduate work at Oregon State University. I also wish to thank the present and past members of the White group, especially Gary Bolton, Alan Johnson, Fraser Fleming, Hyunik Shin and Frank Stappenbeck for their help and discussions.

My thanks also go out to my parents and family, especially my wife Yeon-sil, for their support and for giving me the opportunity to achieve this long trip.

Finally I must also thank Jesus who is my Lord.

TABLE OF CONTENTS

INTRODUCTION	1
DISCUSSION	23
EXPERIMENTAL	60
BIBLIOGRAPHY	91

LIST OF FIGURES

<u>Figure</u>	<u>Page</u>
1. Representative Members of the Trichothecene Family	2
2. <i>p</i> -Bromobenzoate Derivative of Trichodermol (8)	3
3. Retrosynthetic Scheme for T-2 toxin	24
4. Huckel-type Transition State of an Aromatic	25
5. ORTEP of 124	32
6. Regiochemistry of [2+2] photoaddition of Cyclohexenone with 1,1-Dimethoxyethylene	33
7. Solvolytic Rearrangement of a Bicyclo[4.2.0]oct-7-ene to a Bicyclo[3.2.1]oct-2-ene	36
8. Approach Trajectories of a Nucleophile to the Ketone Carbonyl of 133	38
9. Nuclear Overhauser Enhancement of H1 and H5 Upon Irradiation of the C7 Methyl Group	38
10. Cargill Rearrangement of 6-Methylbicyclo[4.2.0]oct-7-en-2-one (163) to 1-Methylbicyclo[3.2.1]oct-6-en-8-one (166)	46
11. Nuclear Overhauser Enhancement of Ha and Hb Upon Irradiation of Hc	49
12. ORTEP of 178	51

APPROACHES TO THE SYNTHESIS OF TRICHOTHECENE

I. INTRODUCTION

Trichothecenes are a family of secondary fungal metabolites produced by organisms such as *Trichothecium*, *Cephalosporium*, *Myrothecium* and *Fusarium* species. The fungi responsible for producing these trichothecenes have been implicated in certain diseases of humans, animals, and plants such as alimentary toxic aleukia and red-mould disease.^{1,2,3} These diseases can result from consumption of contaminated foodstuff.⁴ The biological activity of the trichothecenes, ranging from antibacterial to antifungal to cytotoxic, has created widespread interest in their pharmacological profiles. For example, T-2 toxin (1) was found to be an effective inhibitor of L 1210 leukemia and KB human epidermal carcinoma *in vitro*. Other trichothecenes were shown to inhibit the growth of experimental tumors in rats and to inhibit protein synthesis in *Hela* and *Ehrlich ascites* tumor cells.

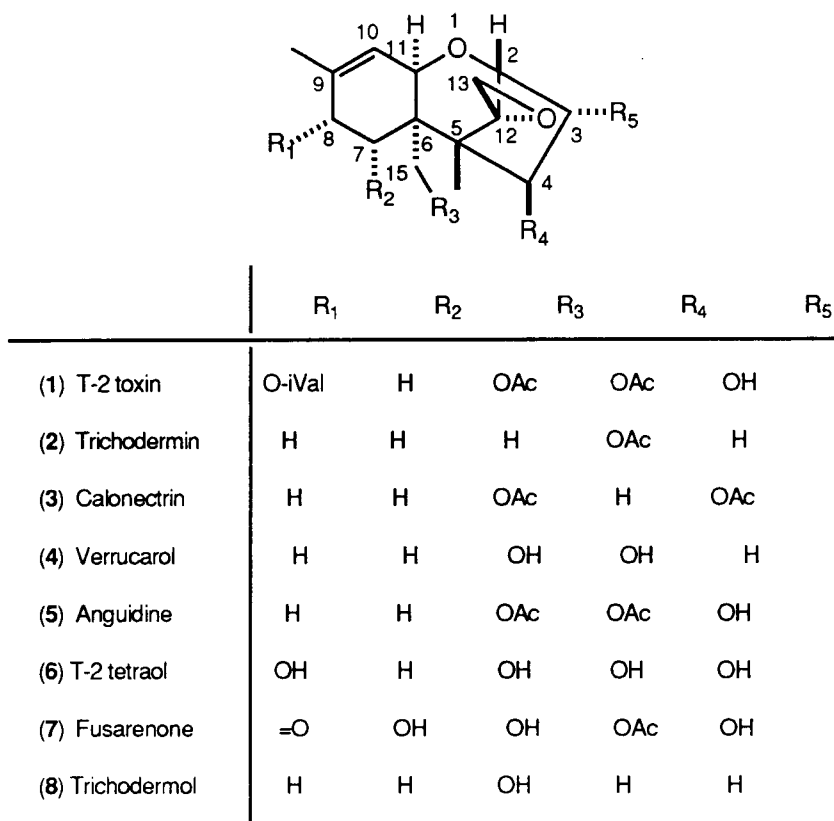

Figure 1 : Representative Members of the Trichothecene Family

The simplest trichothecenes are tetracyclic sesquiterpenes containing a relatively unreactive oxirane moiety. The more complex trichothecenes bear macrocyclic rings linked by ester linkages at the oxygenated C4 and C15 positions of the sesquiterpene nucleus. The structures of several representative non-macrocyclic trichothecenes including T-2 toxin (1) are recorded in Figure 1. Structure-activity relationships for some of the trichothecenes have been examined.⁵ The minimal structural feature required for biological activity in T-2 toxin, for example, is the presence of the C12-C13 epoxide and C9-C10 double bond functionalities. Reduction of the epoxide leads to biologically inactive derivatives while reduction of the olefin greatly diminishes activity.⁶ The epoxide and olefin functionalities have been

implicated in the interaction of trichothecenes with the 60S subunit of an intact 80S ribosome/*mRNA* complex that interferes with peptidyl transferase.⁷ The hydroxyl or ester substituent at C4 is also necessary for *in vitro* inhibition of peptidyl transferase. However, structurally similar trichothecenes can inhibit protein synthesis in fundamentally different ways and, at the present time, there is only a poor understanding of the molecular basis for these activities.

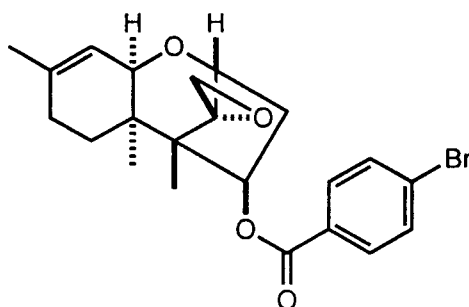

Figure 2 : *p*-Bromobenzoate Derivative of Trichodermol (**8**)

The structure of the first reported trichothecene, trichodermol (**8**), was initially based on spectroscopic analysis and chemical studies. The original structure of trichodermol was later shown to be incorrect. A single-crystal X-ray analysis of the *p*-bromobenzoate derivative of trichodermol (**8**)⁸ revealed its structure as that shown in Figure 2. The spirocyclic epoxide at C12 has been found to be characteristic of all the trichothecenes.

Despite the identification of over 80 non-macrocyclic trichothecenes, only a few have yielded to total synthesis. The first synthesis of a trichothecene sesquiterpenoid was that of trichodermin (**2**), reported by Raphael and Colvin in 1971.⁹ Subsequently, Brooks¹⁴ reported an enantioselective synthesis of the trioxygenated trichothecene anguidine (**5**) in 1983. More recently, several polyhydroxylated trichothecenes have been successfully assembled. Syntheses of calonectrin (**3**) by Kraus,¹¹ and of

verrucarol (**4**) by Schlessinger,¹⁰ Trost¹² and Roush¹³ are especially noteworthy. The most recent efforts in this area have involved an approach to the skeleton of anguidine reported by Ziegler¹⁵ and the synthesis of the tetraacetate of T-2 tetraol (**6**) reported by Colvin in 1990.¹⁶

Previous Strategies for Trichothecene Synthesis

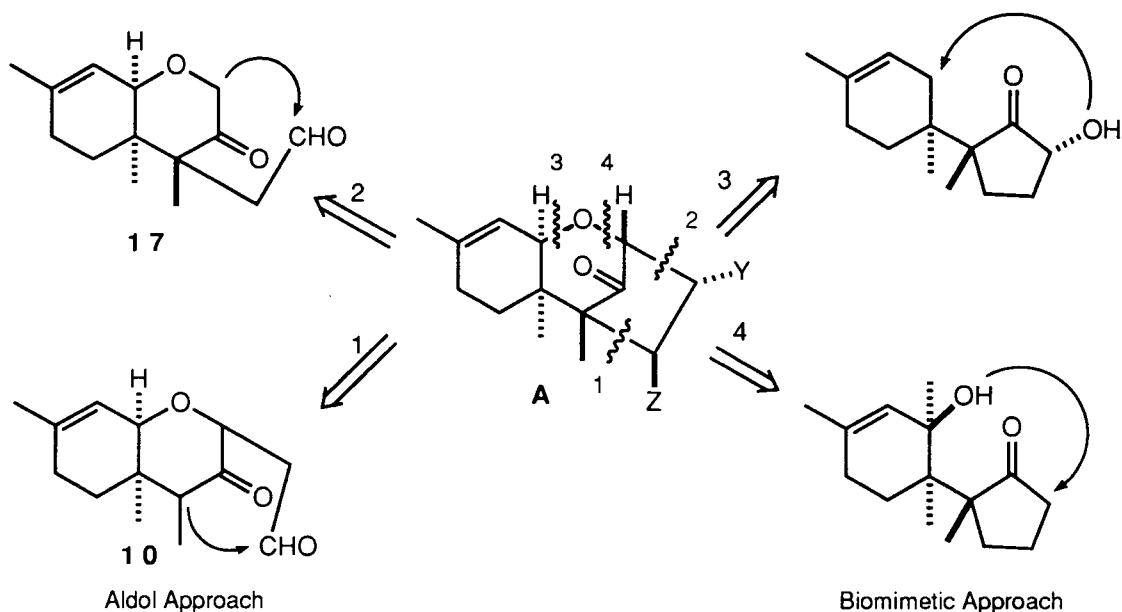

Scheme 1

A survey of trichothecene syntheses in the literature reveals that approaches to the sesquiterpenoid nucleus can be categorized by the type of reaction used to construct the tricyclic ring system from a bicyclic precursor. In a retrosynthetic sense four different disconnections have been employed for assembling the trichothecene skeleton (Scheme 1). Disconnections 1 and 2 imply an aldol approach, while disconnections 3 and 4 represent a biomimetic approach.

The Aldol Approach : Disconnection 1

The first successful synthesis of a trichothecene, that of trichodermin (**2**), involved the aldol disconnection 1. The key intermediate in Colvin's synthesis of **2**⁹ (Scheme 2) was keto aldehyde **10**, which was prepared from *p*-cresol methyl ether (**9**). However, all attempts to effect an aldol cyclization of aldehyde **10** to the tricyclic **A** (Scheme 1) were unsuccessful. Fortunately, a modified approach gave better results; the conversion of **10** to the enol ester **11** and subsequent treatment with one equivalent of lithium tri-*t*-butoxyaluminum hydride of **11** gave the desired aldol product **12** in 7% yield. Trichodermin was synthesized from **12** via a series of five steps.

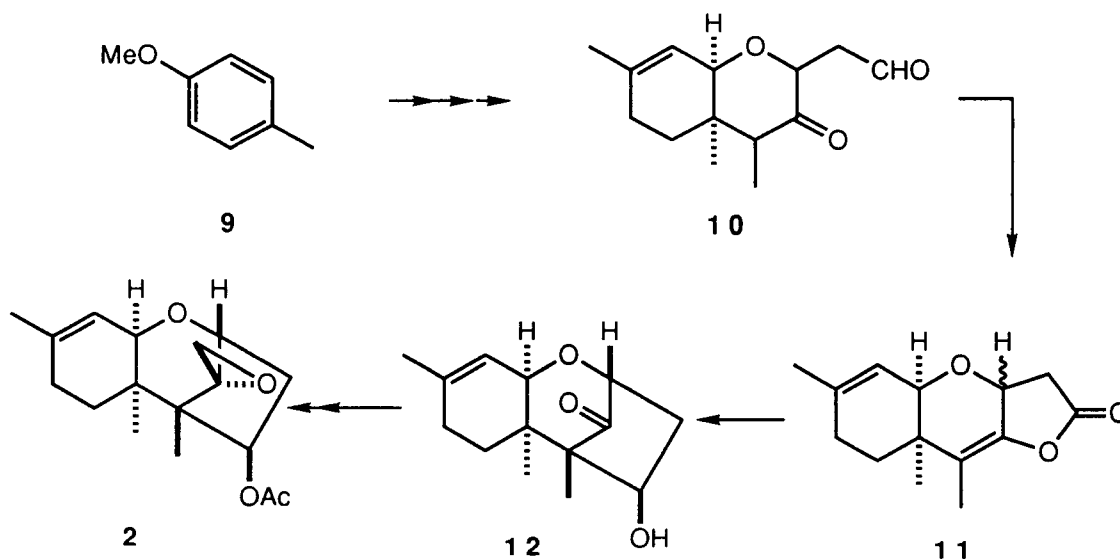

Scheme 2

Colvin and Raphael failed to extend this aldol approach to a synthesis of verrucarol (**4**). In retrospect, the aldol approach represented by disconnection 1, although providing the first successful synthesis of a

trichothecenoid, ranks as the least versatile method for construction of the trichothecene ring system.

An Alternative Aldol Approach : Disconnection 2

Fujimoto and Tatsuno¹⁷ were the first to examine the aldol approach symbolized in disconnection 2 as an entry to the trichothecene skeleton. They employed this stratagem as the key step in their 1974 synthesis of 12,13-epoxytrichothec-9-ene (**19**). The synthesis began with the hydrochromanone **14**, prepared from the keto ester **13** in eight steps (Scheme 3). The stereocontrolled formation of the quaternary center at C5 was achieved via the Claisen rearrangement of enol ether **15**, giving the desired isomer of ketone **16** in 60% yield. The key aldol cyclization of **17** to **18** proceeded in 90% yield. After removal of the 3-hydroxy group of **18**, the C12-C13 epoxide of **19** was formed with the correct stereochemistry via epoxidation of the exo olefin.

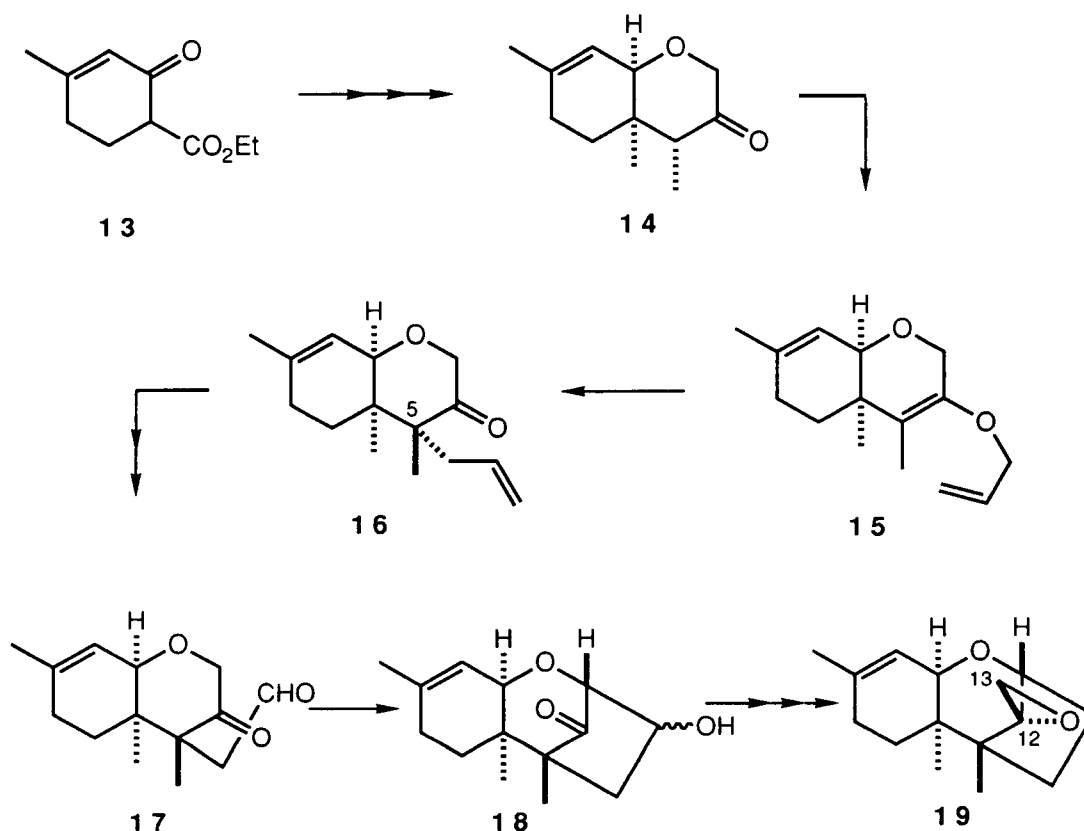

Scheme 3

The same aldol approach has also been used by Kraus and Roth¹¹ to synthesize calonecristin (**3**) (Scheme 4). The synthesis began with preparation of the cyclohexene **22**, constructed via a Diels-Alder reaction, which served to introduce two of the requisite stereogenic centers. Transformation of Diels-Alder adduct **22** to the hydrochromanone **23** was accomplished in 11 steps, highlighted by an intramolecular Knoevenagel condensation. Acylation and O-silylation of **23** yielded **24**, which underwent a fluoride-induced intramolecular alkylation to afford **25** with a high degree of stereocontrol at C5. The key aldol cyclization of **26**, obtained from the reduction and oxidation of **25**, introduced the two carbon bridge of the C ring of **27**.

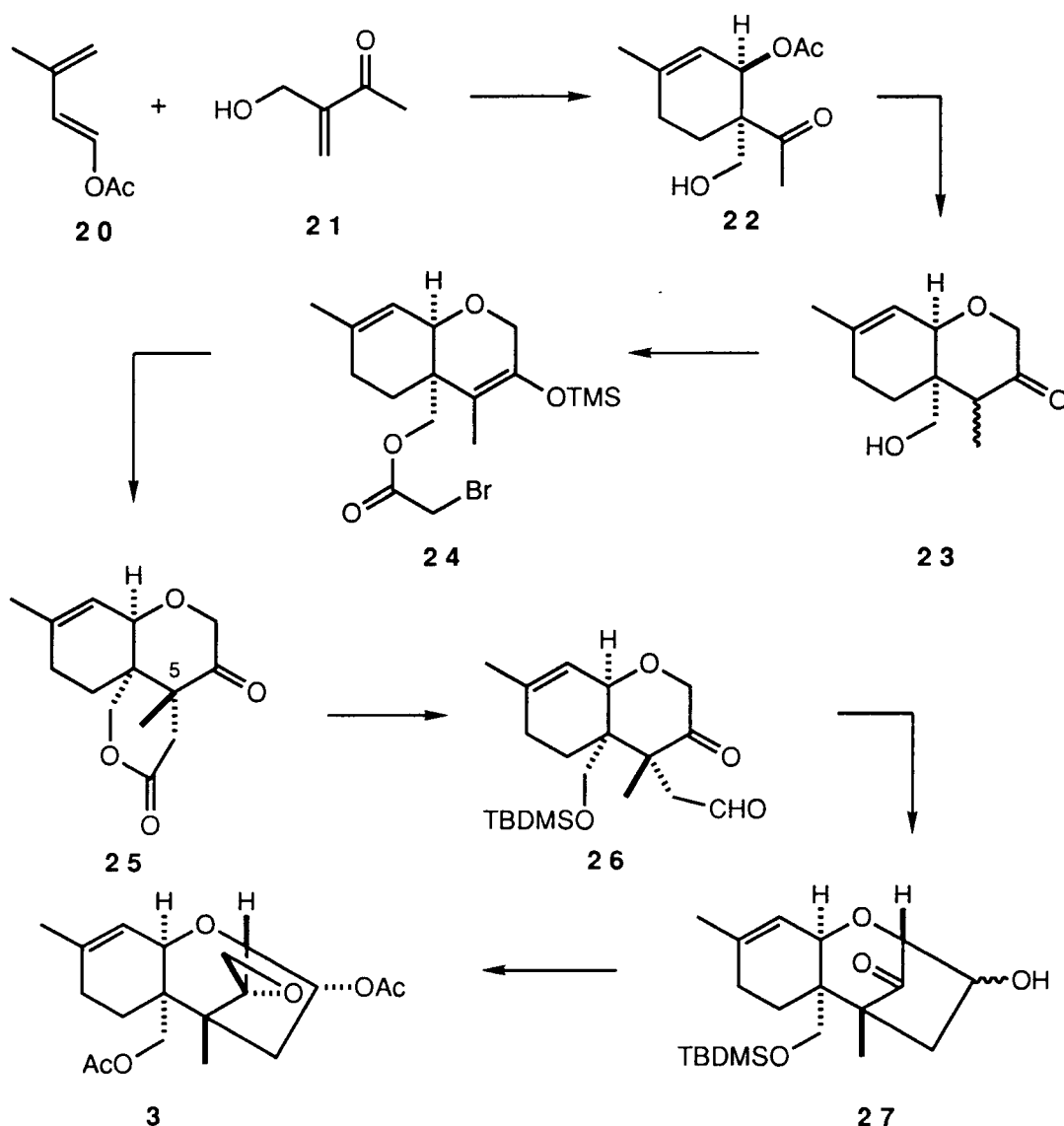

Scheme 4

The synthesis of the tetraacetate **34** of T-2 tetraol (**6**) was reported by Colvin¹⁶ using this variation of the aldol approach 17 years after his trichodermin synthesis was completed (Scheme 5).⁶ The strategy is quite similar to that employed in Fujimoto's synthesis of 12,13-epoxytrichothec-9-ene (**19**).¹⁷ Thus, Claisen rearrangement of **30**, prepared by Diels-Alder addition of isoprene **28** to methyl coumalate (**39**), provided the α -allyl ketone **31**. Catalytic osmylation, followed by periodic acid treatment of **31**, then

resulted in keto aldehyde **32**. Aldol cyclization of **32** followed by alcohol protection gave the tricyclic system **33**, from which **34** was obtained by straightforward means.

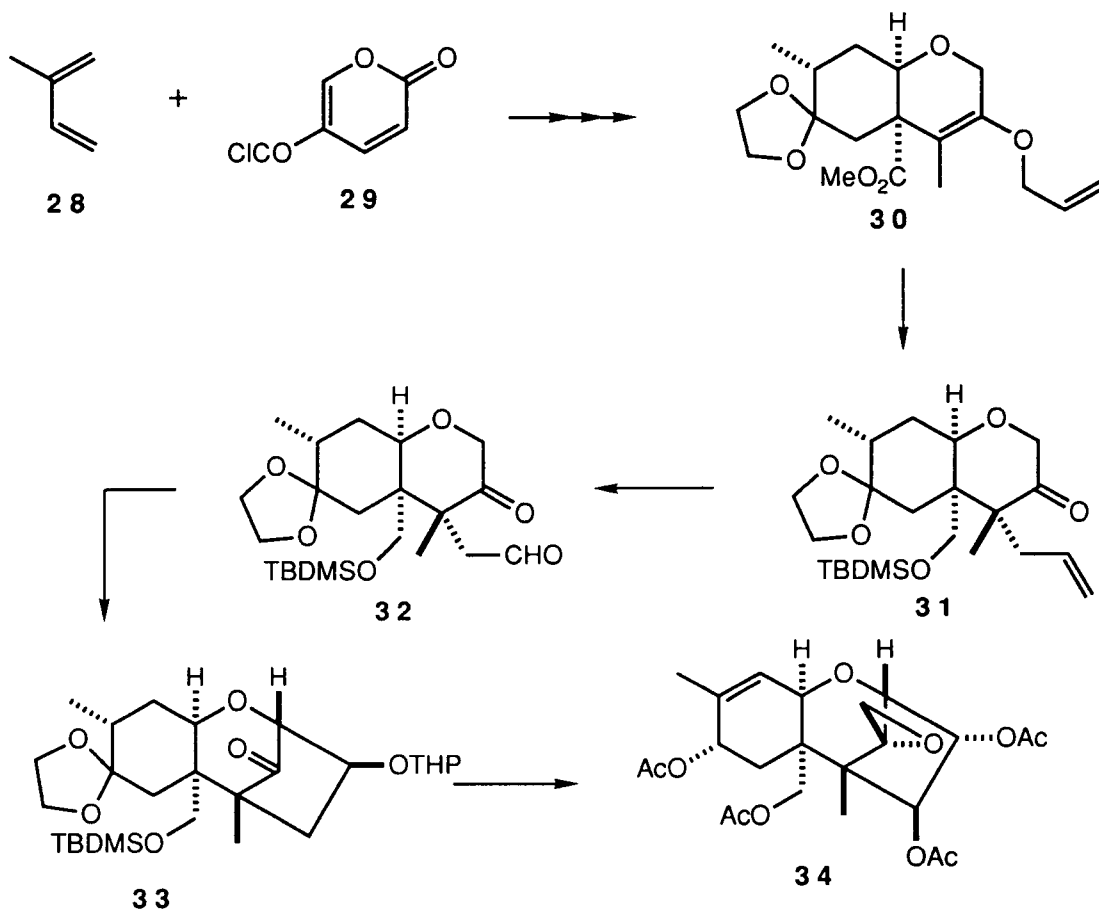

Scheme 5

Several studies have been undertaken in order to elucidate the biosynthesis of trichothecenes. Isotopic labelling experiments using radioactive precursors such as [3-³H]-geranyl pyrophosphate, [2-¹³C]-mevalonic acid (**35**) and [2-³H]-farnesyl pyrophosphate have delineated the biosynthetic pathway to trichodiene (**38**).¹⁸ Feeding experiments using C2-labelled mevalonic acid **35** led to 6,7-*trans*-farnesol pyrophosphate (**36**) labelled as shown in Scheme 6 and thus to **37**. The isolation of trichodiene

(**38**) and trichodiol (**39**) from *Trichothecium roseum*¹⁹ has been rationalized via the Wagner-Meerwein shifts in structure **37**. A pair of 1,2-methyl shifts and a 1,4-hydride shift would give trichodiene (**38**).²⁰ Hanson suggested the trichodiol epoxide **39** as an intermediate in the conversion of **38** into 12,13-epoxytrichothec-9-ene (**40**).^{18b}

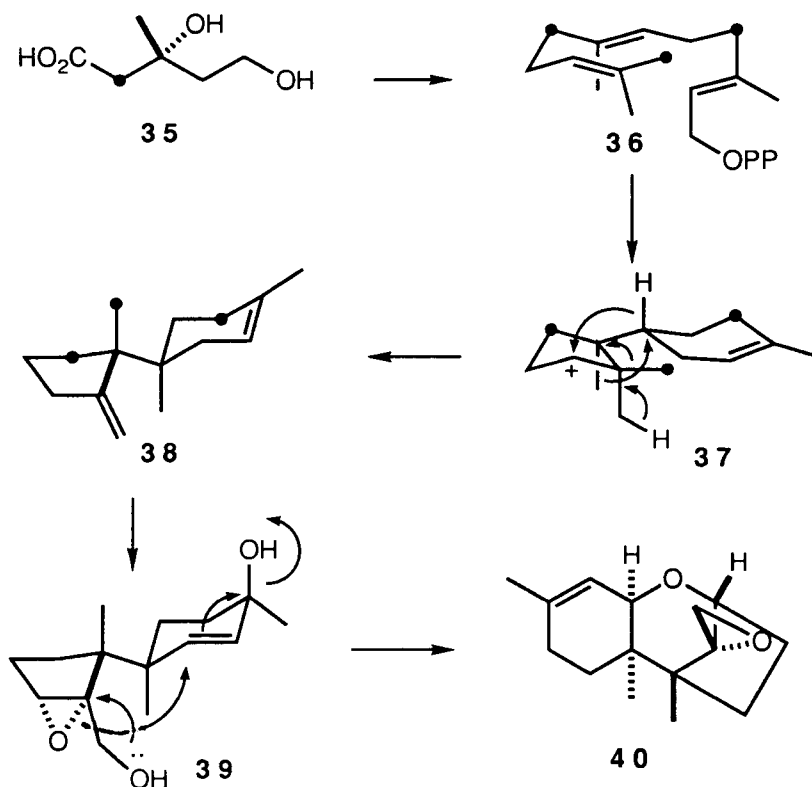

Scheme 6

The Biomimetic Approach : Disconnection 3

A biomimetic approach along lines of disconnection 3 has been the most popular route to the trichothecene skeleton. This biomimetic cyclization can proceed via either an allylic carbonium ion (path A) or a Michael reaction (path B). While path A yields the desired C9-C10 olefin directly, path B yields

a C9 keto group which must then be transformed into the olefin (Scheme 7). Hence, path A, which can also be entered from the enone, is the superior route. The principal challenge of this biomimetic approach has been control of the relative stereochemistry at the two quaternary centers C5 and C6.²¹

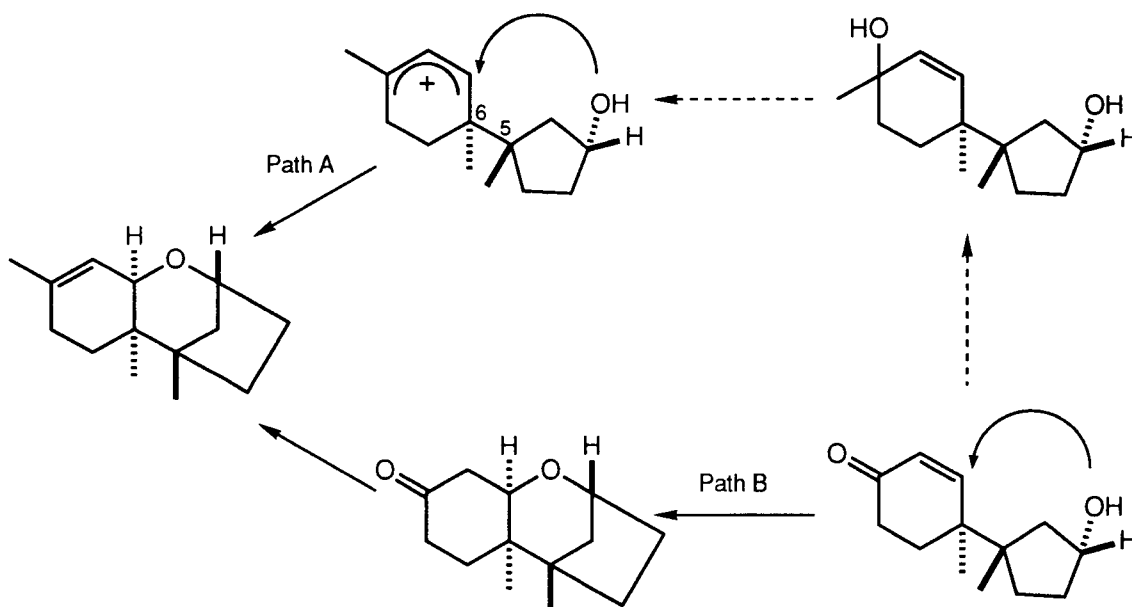

Scheme 7

Masuoka and Kubota^{21a} reported the synthesis of the mycotoxin 12,13-epoxytrichothec-9-ene (**19**) based on this biomimetic strategy (Scheme 8). The desired configuration at C5 and C6 was obtained by a [2+2] photoaddition, and the photoadduct **43**, when hydrolyzed by acid, underwent fragmentation to yield dione **44**. After subsequent manipulations involving 8 steps, sodium borohydride reduction of the keto function yielded alcohol **45** with the incorrect stereochemistry for cyclization. This problem was circumvented by an alcohol inversion sequence. Methylation then furnished diol **46** which, upon exposure to acid, yielded the trichothecene **47**. This ring closure as applied to the trichothecene series yielded only *cis* fused product.

Treatment of the trichothecene **47** with *m*-chloroperbenzoic acid resulted in 12,13-epoxytrichothec-9-ene (**19**).

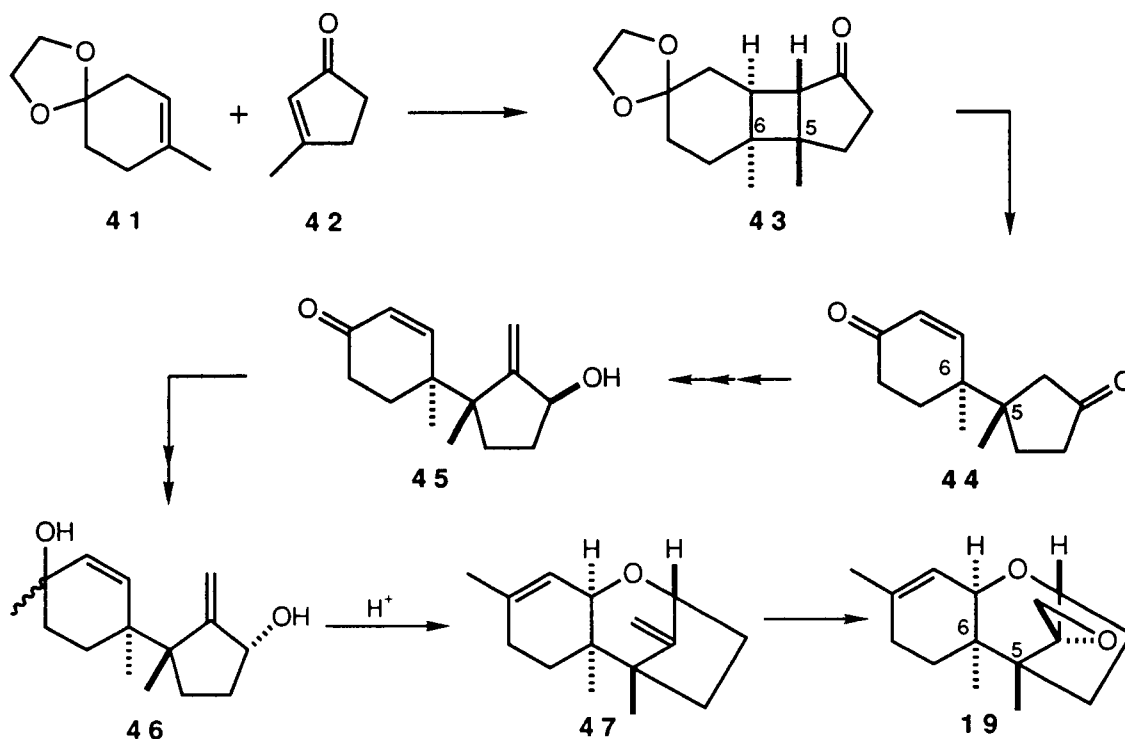

Scheme 8

Still and Tsai^{21b} also exploited disconnection 3 of Scheme 1 in their trichodermol (**8**) synthesis (Scheme 9). The unique feature of their plan was Favorskii ring contraction of the Diels-Alder adduct **50** to cyclopentenone **51** via basic epoxidation and Grob fragmentation of the hydroxy mesylate **52** to the bicyclic **53**. The latter established the desired configurational relationship between C5 and C6. After removal of the benzoate group from **53**, hydroxyl directed epoxidation of the cyclopentene double bond yielded **54**. Acidic hydrolysis of epoxide **54** furnished the trichothecene skeleton **55** in 60% yield. Six steps involving standard reactions were required to complete the synthesis of **8** from **55**.

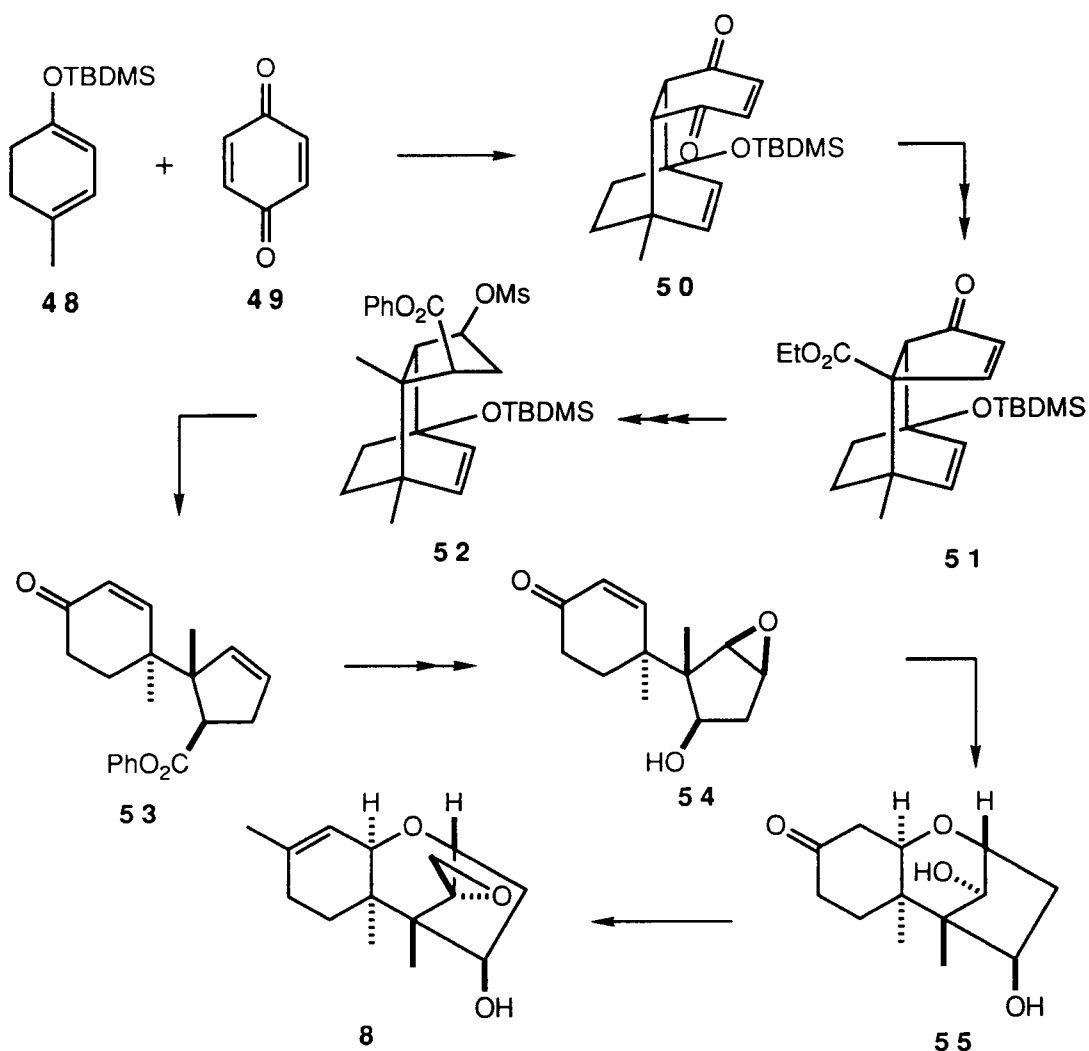

Scheme 9

The dienylm iron complex **56** was utilized by Pearson^{21c} to obtain a 1:1 mixture of the bicyclic diene diastereomers **58** and **59** in his model trichothecene synthesis (Scheme 10). The ketone carbonyls were reduced to alcohols **60** and **61** by sodium borohydride and the alcohols were equilibrated to a mixture in which the desired diastereomer predominated. After a further series of manipulations, a tandem epoxide opening-cyclization of **62** led to the trichothecene skeleton **63**.

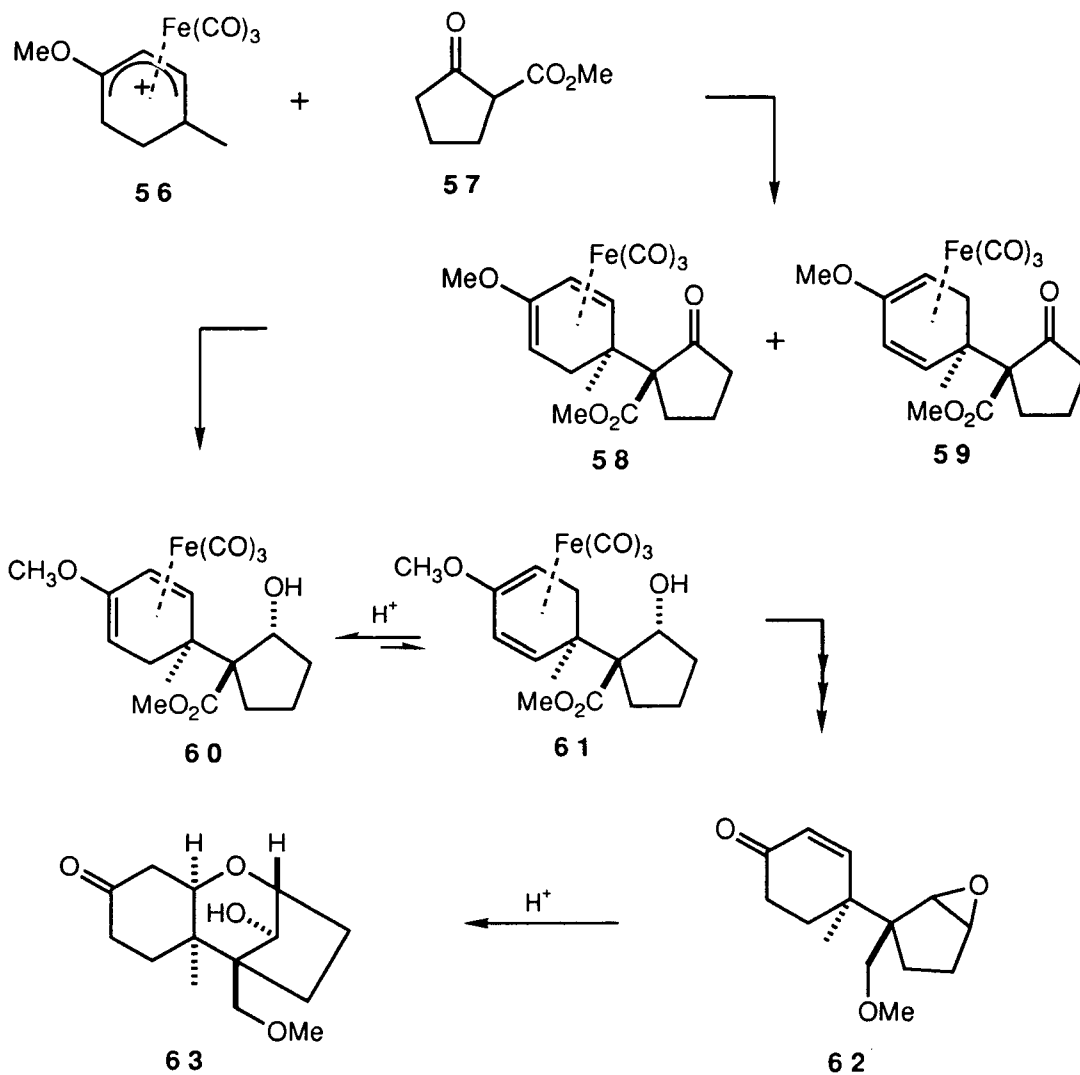

Scheme 10

Schlessinger^{21d} reported a synthesis of verrucarol (**4**) based on a biomimetic approach (Scheme 11). He prepared as a key intermediate the bicyclic lactone **65** in ten steps from the dione **64**. The Diels-Alder reaction of **65** with 1-methoxy-3-(trimethylsilyloxy)-1,3-butadiene (**66**), followed by hydrolysis and elimination, furnished the enone **67**. Selective addition of methyl lithium to **67** afforded **68**. Reduction of **68** with lithium aluminum hydride yielded **69** which was cyclized under acidic catalysis to give **70**. The tricyclic diene **70** was converted to verrucarol (**4**) via a series of four steps.

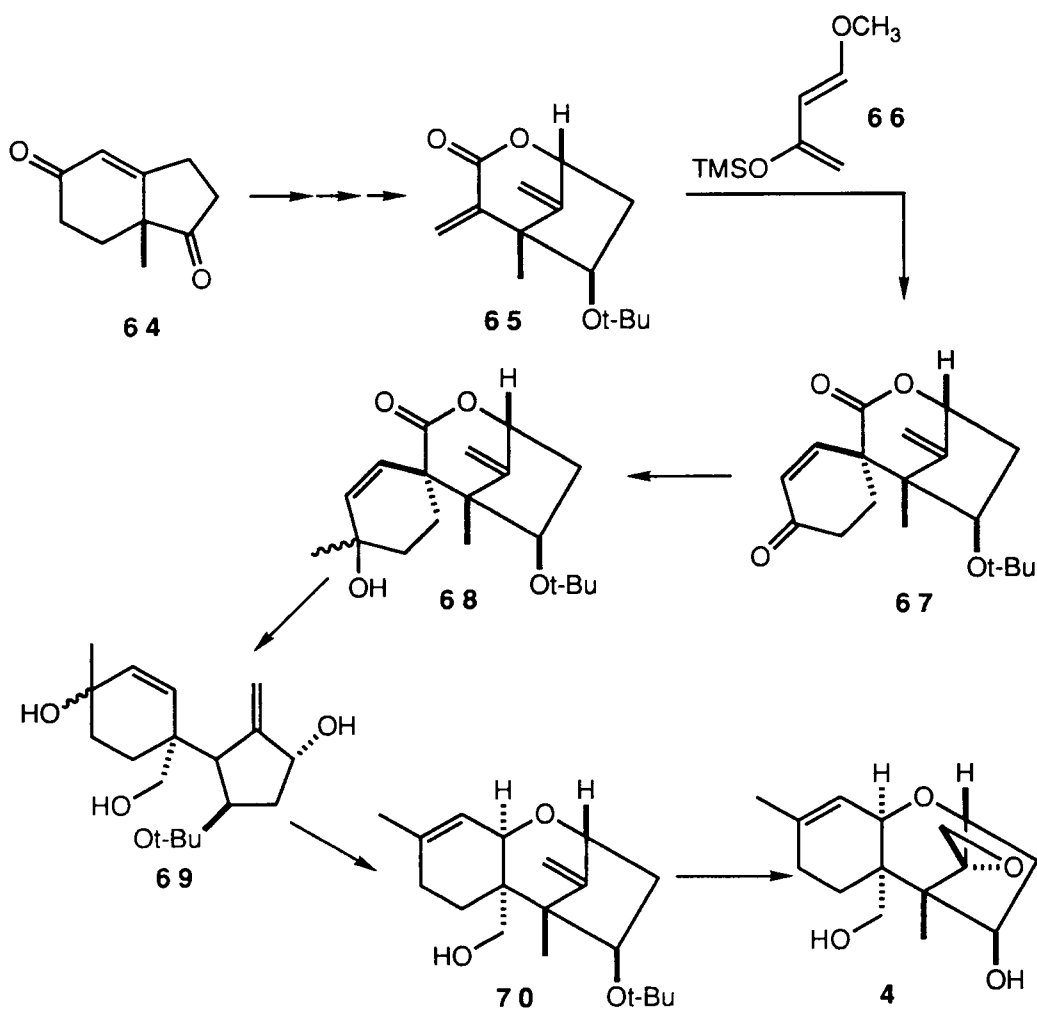

Scheme 11

Roush¹³ reported a synthesis of verrucarol (4) which closely parallels the route of Schlessinger described above. The diol **72** was obtained from 1-trimethylsilyl-3-methylcyclopentadiene (**71**) in ten steps (Scheme 12). After protection of diol of **72**, the lactone **73** was reacted with 1-acetoxy-3-methyl-1,3-butadiene (**74**) to give **75** as a mixture of diastereomers. Reduction of **75** with lithium aluminum hydride yielded triol **76**, which upon exposure to acid gave the skeleton of verrucarol. The triol **77** was converted to verrucarol (**4**) in six steps.

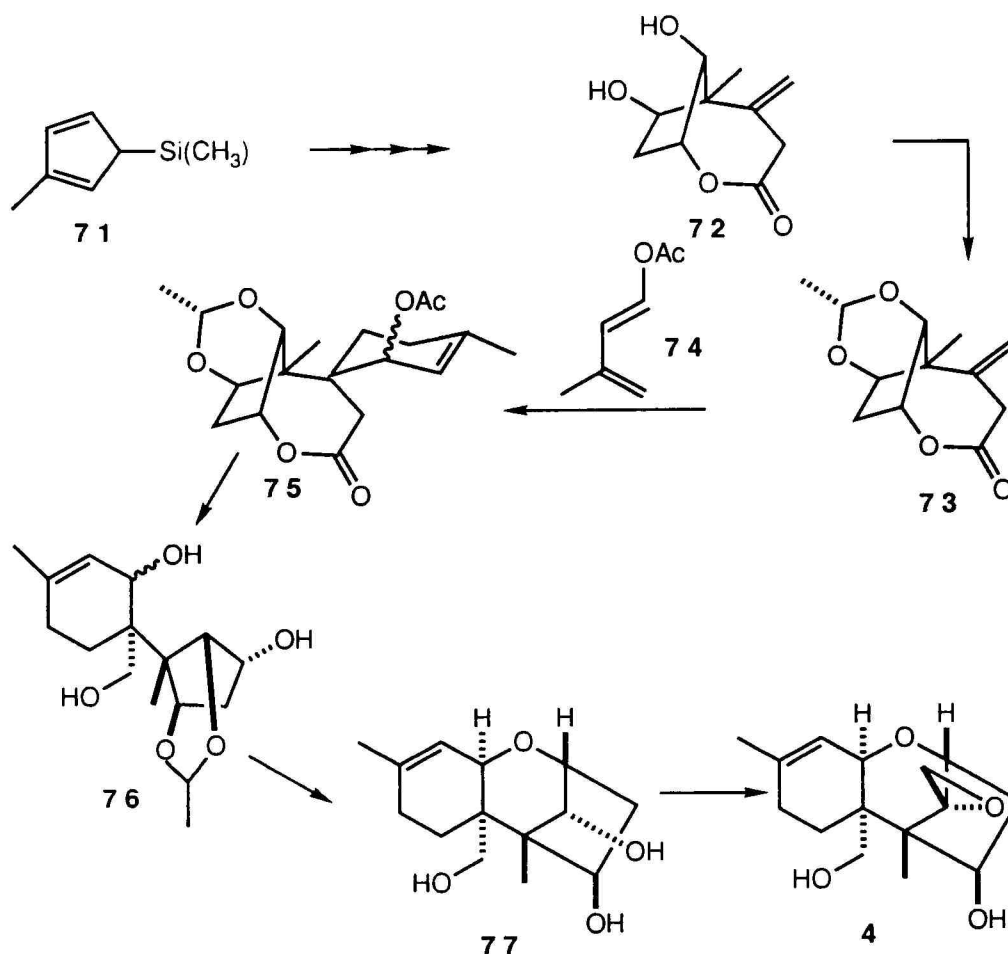

Scheme 12

The first chiral synthesis of a trichothecene, anguidine (**5**), was reported by Brooks and Grothaus.¹⁴ Their synthesis started with an enantioselective microbial reduction of dione **78** yielding the undesired stereoisomer of alcohol **79** (Scheme 13). After an alcohol inversion sequence, a series of seven steps furnished the optically pure cyclopentane **80**. Further elaboration of **80** led to the heavily substituted oxabicyclo[3.2.1]octane **81**. The A ring was incorporated by a Robinson annulation which provided the desired stereochemistry at C5 and C6 in **82**. Reduction of **82** yielded the precursor **83** for cyclization to the trichothecene nucleus after protection of the primary alcohol. Cyclization smoothly afforded the 13-nortrichothecene **84**. A series of

standard reactions completed the synthesis yielding the natural antipode of anguidine (**5**).

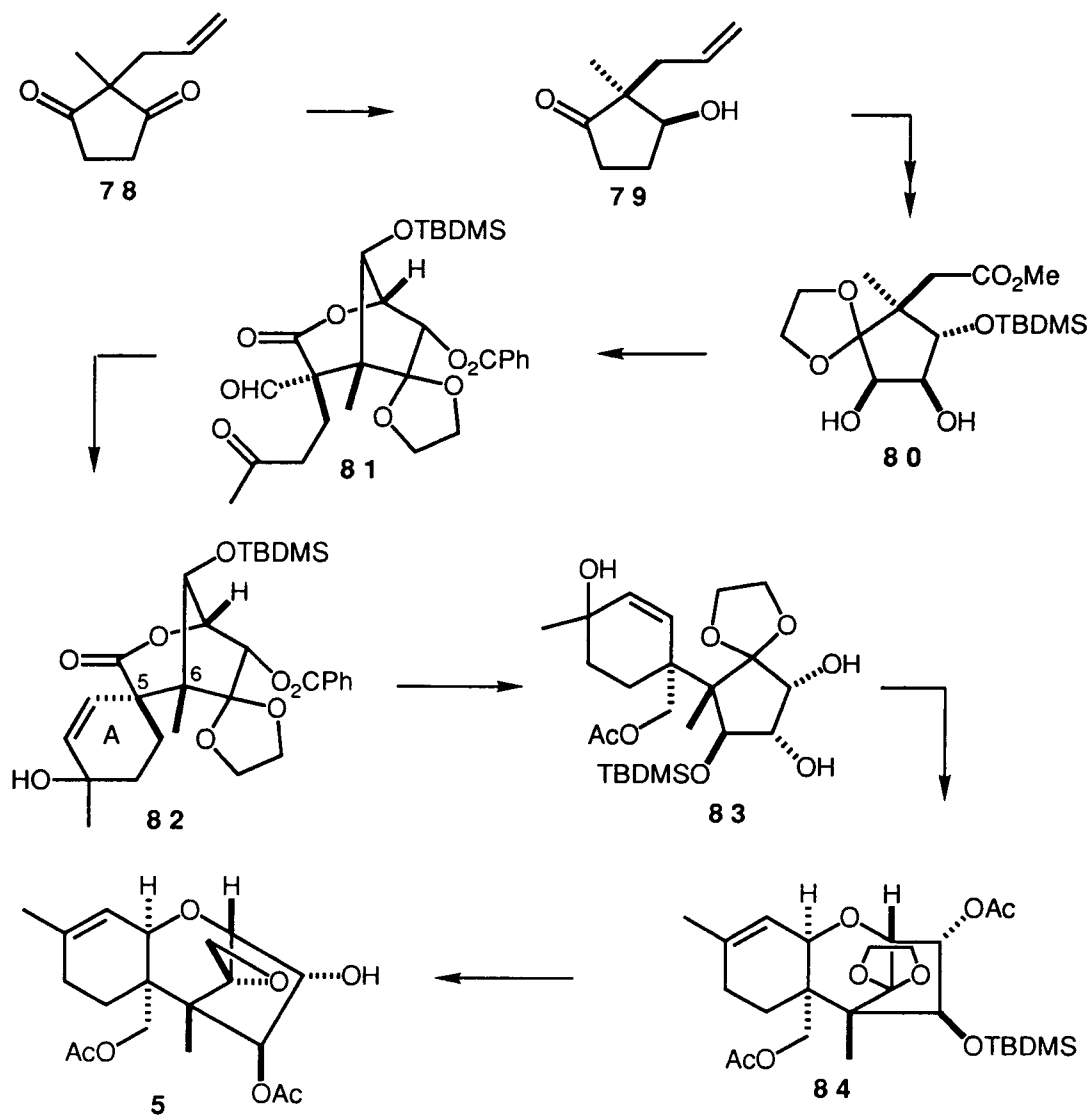

Scheme 13

Biomimetic Approach : Disconnection 4

Trost and McDougal¹² successfully applied this biomimetic approach to the synthesis of verrucarol (**4**). As shown in Scheme 14, their synthesis started with the conversion of 2-methyl-1,3-cyclopentadione (**85**) to the acrylate **86** in which the quaternary carbon was installed by a Claisen rearrangement. Diels-Alder reaction of **86** with the diene **87** afforded **88**. Further heating of **88** yielded the tricyclic compound **89** via an intramolecular ene reaction. After reduction and oxidation, a retro ene reaction furnished **90**. Following introduction of bromine at C2 in **90**, the stereochemistry at C11 was inverted with trifluoroacetic acid, yielding **91**. The key cyclization of **91** was carried out in 70% yield using fluoride ion as a catalyst, thus completing the carbon skeleton of verrucarol (**4**). A series of 8 steps closed out the synthesis of **4**.

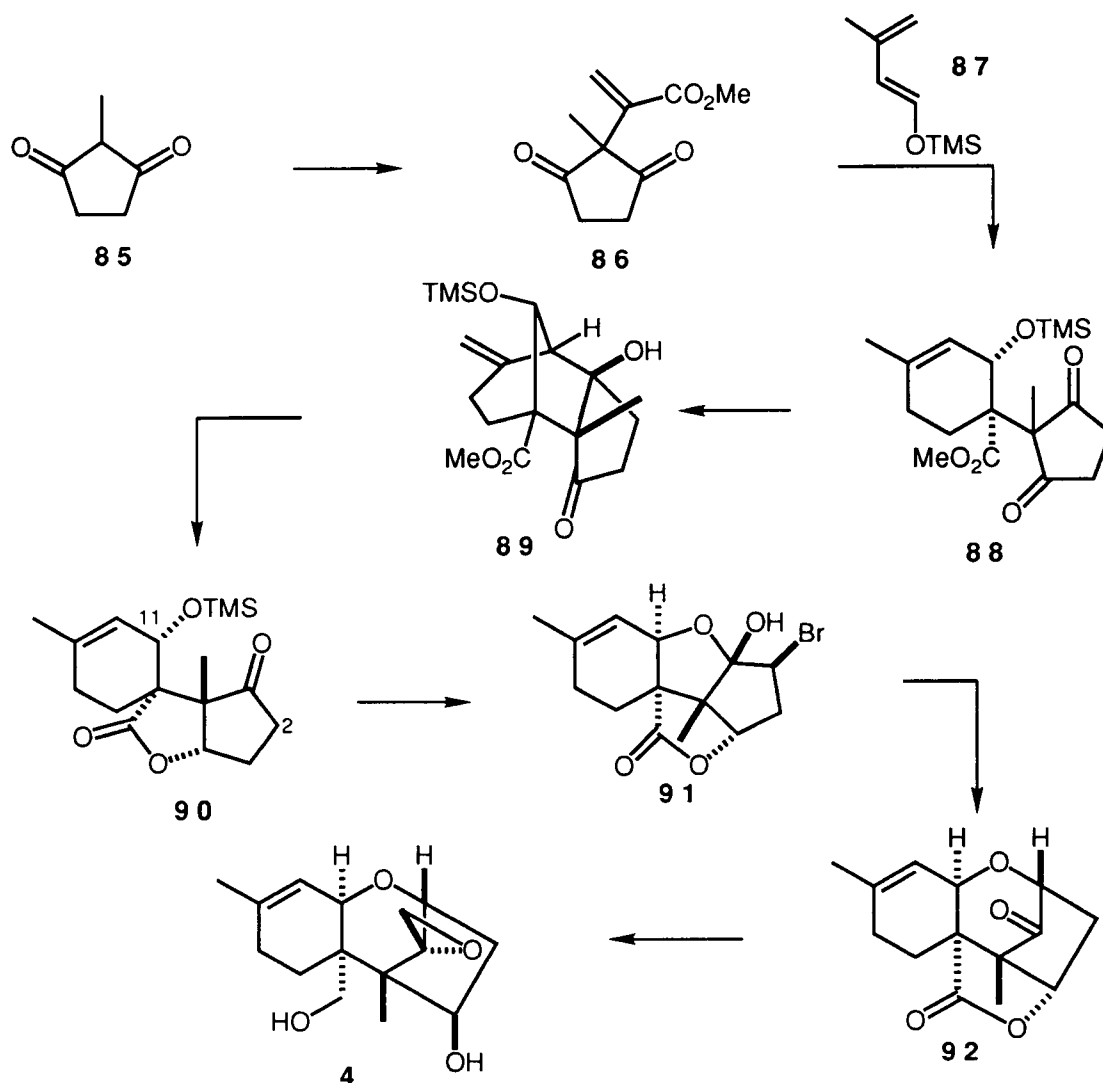

Scheme 14

In 1990, Ziegler¹⁵ reported a synthesis of the carbon ring skeleton of anguidine (**5**) based on the disconnection 4 approach (Scheme 15). A Lewis acid-catalyzed carbonyl ene reaction of **93** afforded, after reduction, silylation and methoxymethylation, the cyclohexane **94**. Reaction of **94** with singlet oxygen provided the diol **95**, which was desilylated with tetra-*n*-butylammonium fluoride. Bromoetherification with 2,3,3,6-tetrabromocyclohexadienone then gave **96**. Treatment of **96** with *m*-chloroperbenzoic acid gave an epoxide which was transformed into its

diacetate **97** for the critical cyclization. Opening of epoxide **97** with boron trifluoride etherate yielded **98**. Deprotection, selective acetylation, and Dess-Martin periodinane oxidation of **98** resulted in **99**. Subsequent reductive cleavage of the bromo ether residue of **99** with zinc dust generated the hydroxyl and olefin functionality of **100**. However, Ziegler failed to accomplish isomerization of this exocyclic olefin to the required C9-C10 endocyclic double bond of **101** at the final stage of his approach to anguidine.

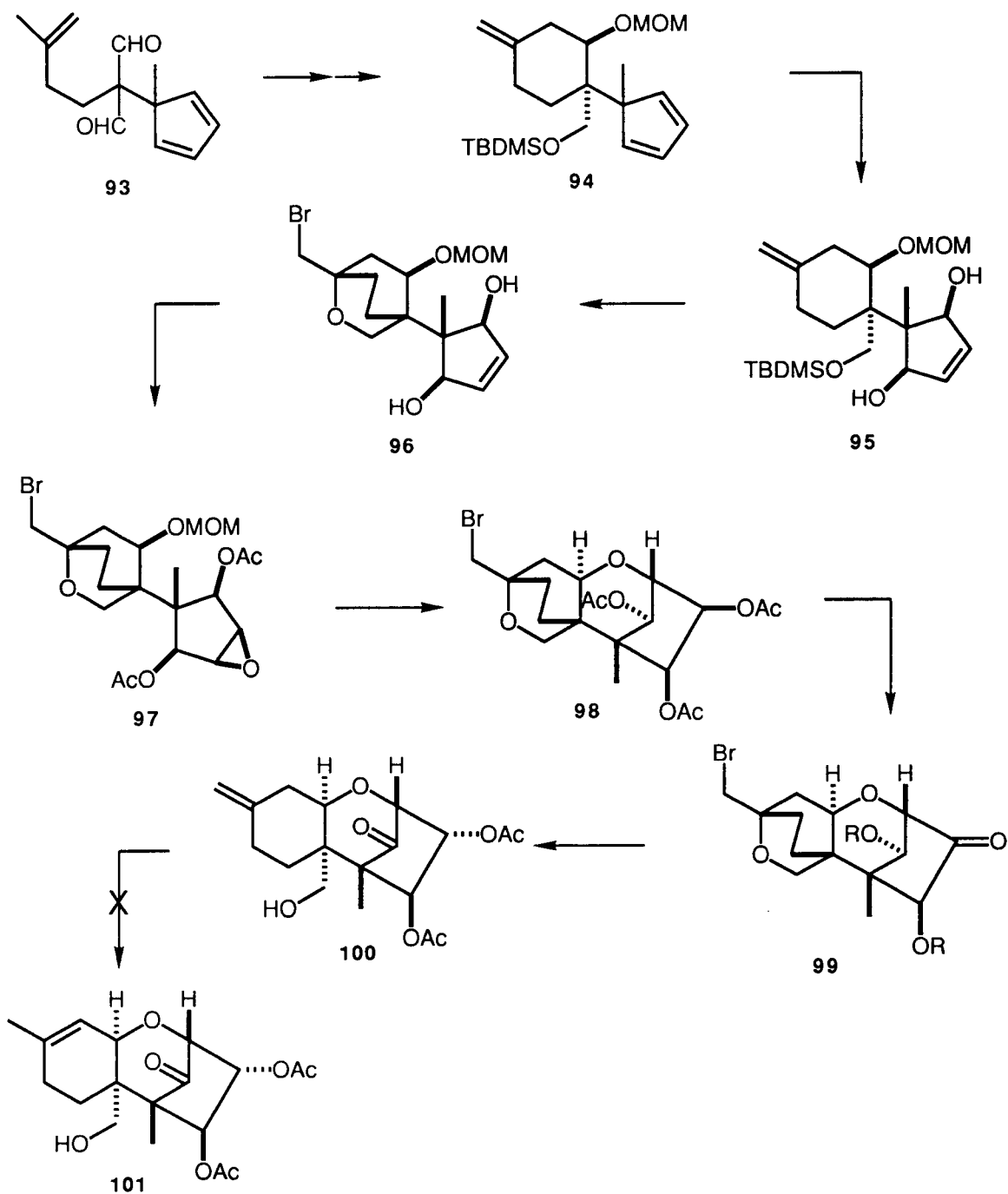

Scheme 15

With this substantial background of previous synthetic effort in the trichothecene area, the goal of this research became the development of a conceptually different method for the synthesis of trichothecenoids. The initial

objective was formation of the carbon skeleton of T-2 toxin (**1**), but it was envisioned that the route chosen would be amenable to modifications leading to other members of this class of sesquiterpenes.

II. DISCUSSION

Our plan, in retrosynthetic format, directed toward T-2 toxin (**1**) is represented in Figure 3. It can be described as a "B-A-C" approach in which the A-B ring system is formed first via a Diels-Alder reaction. The five-membered C ring would then be constructed via a [2+2] photoaddition with acetylene followed by ring enlargement of the resulting cyclobutene. The key ring expansion was expected to proceed via solvolytic rearrangement of a cyclobutenyl carbinol. Transposition of the enone function would be necessary prior to [2+2] photoaddition. The A ring methyl group at C9 and the C9-C10 double bond would be incorporated via Grignard reaction at the C9 carbonyl (trichothecene numbering) followed by elimination of the resulting tertiary alcohol. A Prevost reaction was envisioned as the source of the diol at C3, C4.²² Finally, the oxirane unit would be formed from an exocyclic olefin, which would be obtained by Wittig reaction of a C12 ketone employing methodology used by Trost in his verrucarol synthesis.²³

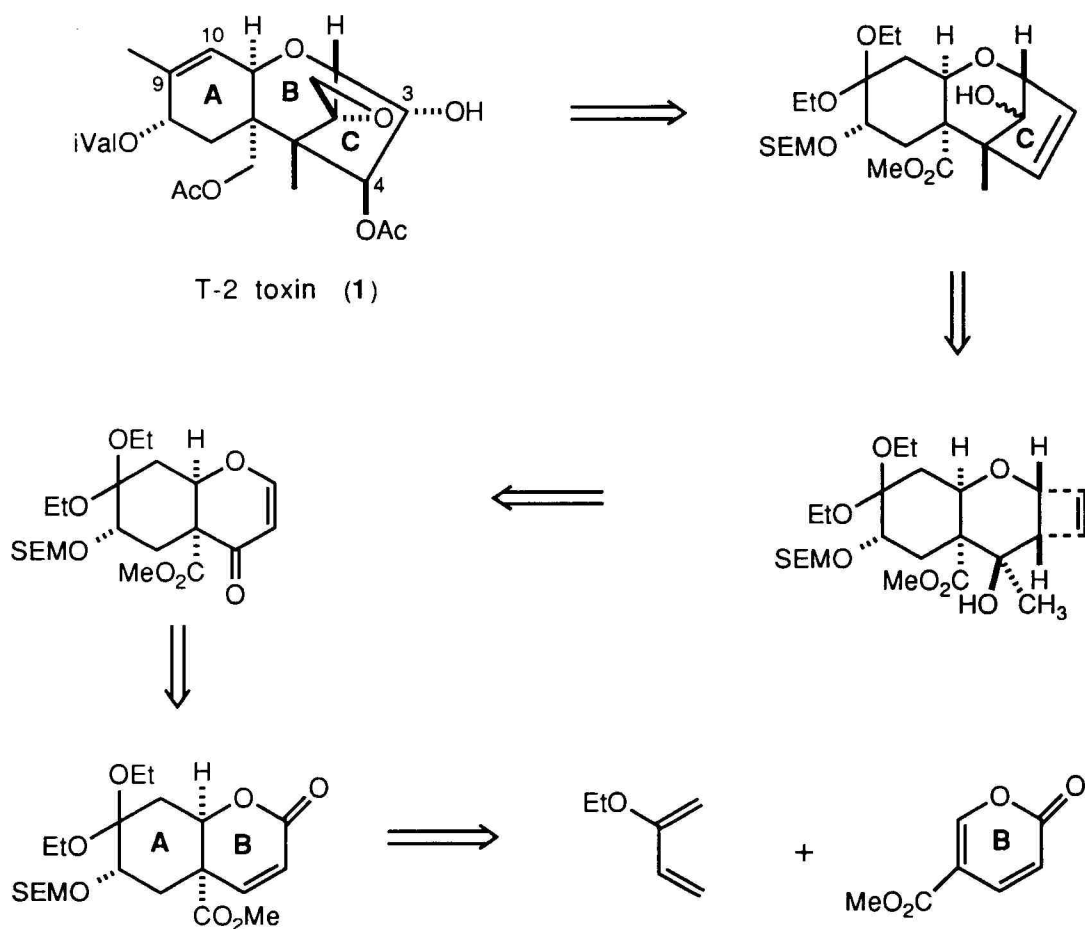

Figure 3: Retrosynthetic Scheme for T-2 toxin

Construction of the AB ring system began with the Diels-Alder reaction of 2-ethoxy-1,3-butadiene (**102**) with methyl coumalate (**103**) to yield adduct **105**.²⁴ The regiochemistry of this [4+2] cycloaddition is governed by the directing groups present in the diene and dienophile. In the case of 2-substituted dienes such as 2-ethoxy-1,3-butadiene the regiochemistry of Diels-Alder addition to an olefin which is activated by an electron withdrawing group (EWG) is known to be predominantly "para". The regiochemistry can be explained using molecular orbital theory.²⁵ In an aromatic, Huckel-type transition state like that shown in Figure 4, complementarity can occur between the electron-withdrawing and electron-donating substituents when

they are "para". Therefore, **105** and not **104** is the expected product from the reaction of **103** with **102**. Diels-Alder adduct **105** was treated with *p*-toluenesulfonic acid in ethylene glycol to afford **106**. Physical data for **106** were identical with those reported for the ketal²⁶ which had been prepared from methyl enol ether **107** in the same manner as ethyl enol ether **105** (Scheme 16). An X-ray crystal structure of **106** obtained from **107** had been obtained previously and had shown the compound to possess the expected regiochemistry.²⁷

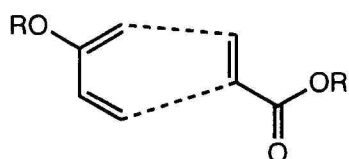
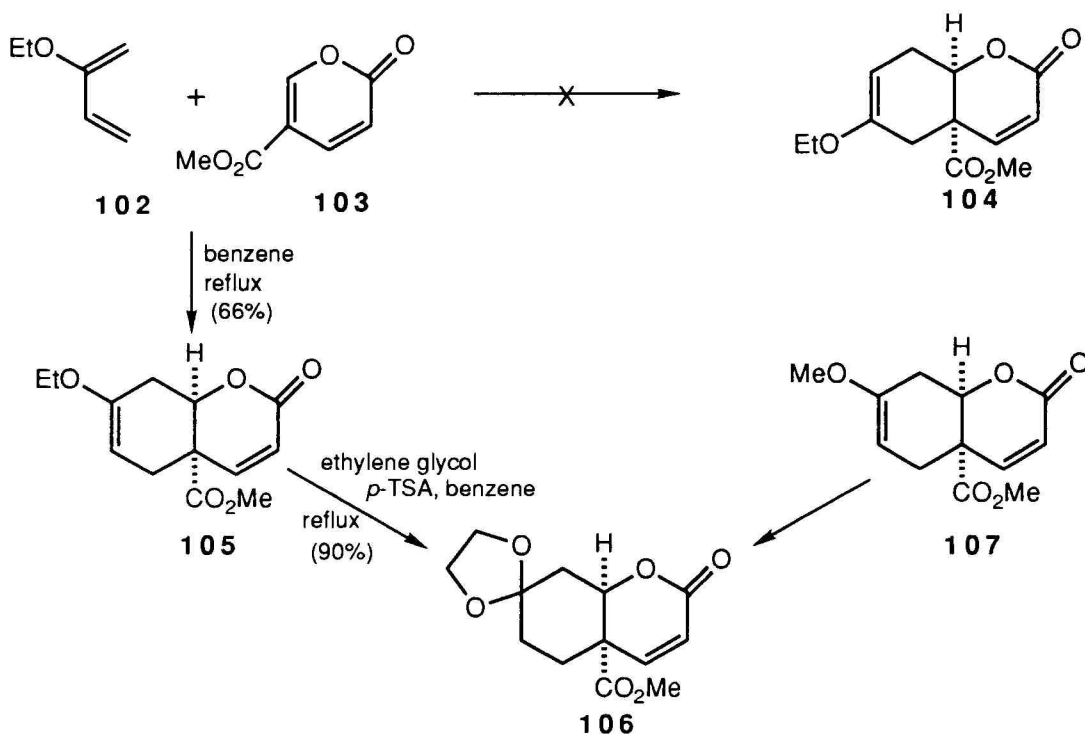
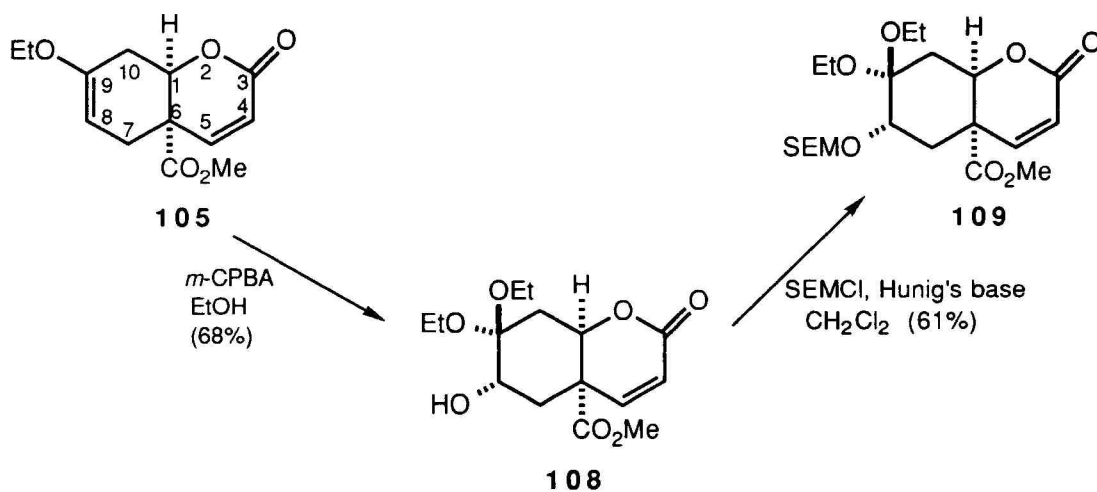

Figure 4 : Huckel-type Transition State of an Aromatic



Scheme 16

The *cis*-fused bicyclic lactone **105** appeared to be a versatile precursor to the AB ring system of the trichothecenes, including T-2 toxin. Epoxidation of **105** using *m*-chloroperbenzoic acid in ethanol²⁸ was expected to occur at the more electrophilic olefin site in ring A from the less hindered *exo* face. Alcoholysis would then yield a hydroxy group at C8 needed for synthesis of the A ring of T-2 toxin and related trichothecenes. Treatment of **105** with *m*-chloroperbenzoic acid in ethanol afforded **108**, and the alcohol was protected as its 2-(trimethylsilyl)ethoxymethyl ether yielding **109** (Scheme 17).²⁹



Scheme 17

In order to annulate a cyclobutene on to C3-C4 of this bicyclic core structure, transposition of the enone function of **109** to that of **111** was required (Scheme 18). Since transpositions of allylic alcohols are well known,³⁰ **109** was reduced with diisobutylaluminum hydride to the lactol **110** with the intention of oxidizing this substrate to effect rearrangement. Oxidation with pyridinium chlorochromate (PCC)³¹ is one of the most frequently used methods for this process. However, chromium (VI) oxidation of allylic lactol

110 using pyridinium chlorochromate or Collins' reagent³² gave back lactone **109** rather than the desired 4-pyranone **111**. The reluctance of **110** to undergo oxidation with transposition can be attributed to the fact that the intermediate, bulky chromate ester will not migrate to the more sterically hindered C5 position.

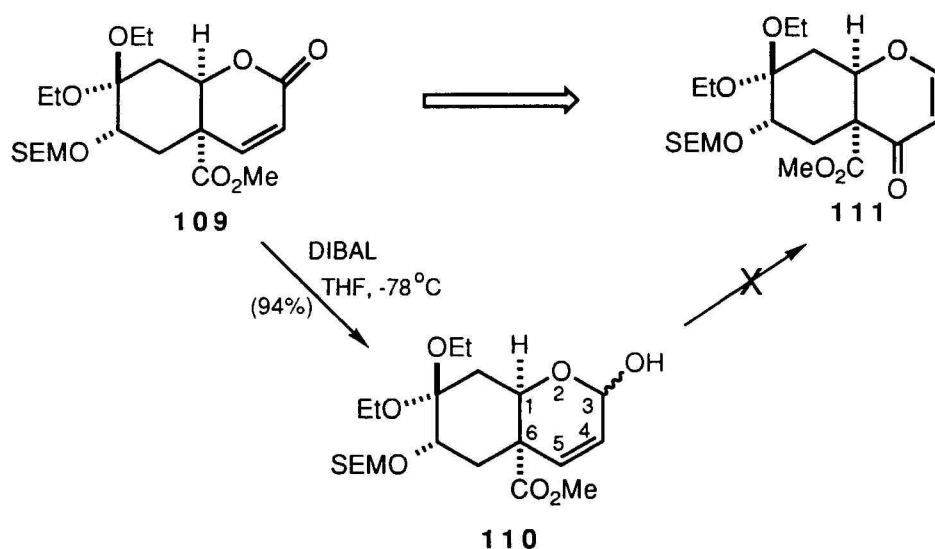

Scheme 18

An alternative possibility for converting **110** to **111** would be [2.3]-sigmatropic rearrangement using phenyl sulfenyl chloride³³ or [3.3]-sigmatropic rearrangement employing N,N-dimethyl thiocarbamoyl chloride.³⁴ However, only the starting material **110** was recovered from attempted sulfenate-sulfoxide rearrangement, and treatment of **110** with sodium hydride and N,N-dimethyl thiocarbamoyl chloride resulted in decomposition.

Palladium(II)-catalyzed transposition of allylic acetates has been developed independently by Henry^{35a} and by Overman,^{35b} and Grieco has exploited this rearrangement with conversion of **112** into **113** in his approach to prostaglandins (Scheme 19).³⁶ Following this protocol, lactol

110 was acetylated with acetic anhydride to afford allylic acetate **114** (Scheme 20). However, attempts to effect Pd(II)-catalyzed rearrangement of **114** using Pd(OAc)₂, Pd(CH₃CN)₂Cl₂ or Pd(OAc)₂(PPh₃)₂ resulted in no reaction. Usually, the driving force for Pd(II)-catalyzed rearrangement is the formation of a thermodynamically more stable olefin or the removal of steric congestion at the site of the acetate group.^{35b,36} Allylic acetate **114** appears to have little effective driving force for rearrangement on this basis but it is, nevertheless, surprising that none of the isomeric acetate **115** is present in this presumed equilibration process.

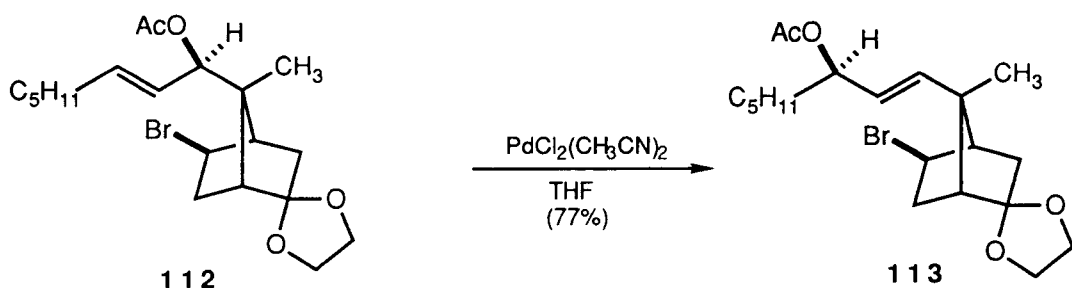

Scheme 19

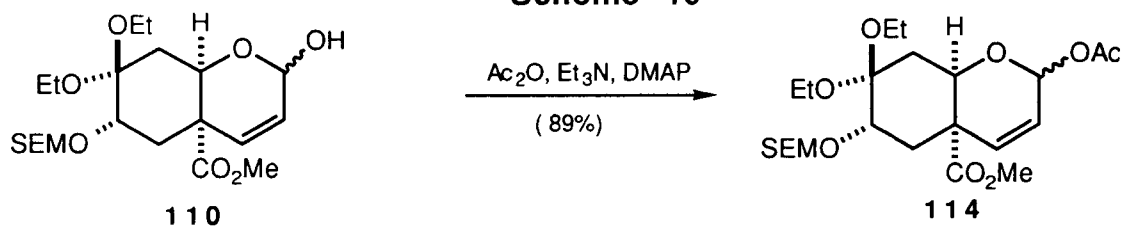

Scheme 20

Since attempts to prepare **111** had been unsuccessful, an alternative approach to this pyranone derivative was sought. Although there was no precedent in which a 4-pyranone operated as a dienophile in the Diels-Alder reaction,³⁷ 3-carbomethoxy-4-pyranone (**116**) was thought to be a good candidate as an effective dienophile because of the activation of the C2-C3 double bond by the carbomethoxy group (Scheme 21).

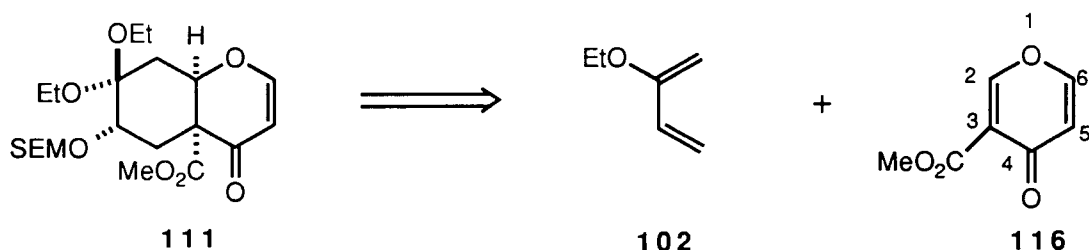

Scheme 21

At the outset of this work preparative routes to 4-pyranones bearing a carboalkoxy function at C-3 position were not well known, and consequently a general method for synthesizing these useful dienophiles was developed. The 4-pyranone **116** was readily prepared from methyl 3,3-dimethoxypropionate (**117**) in four steps in 39% overall yield.

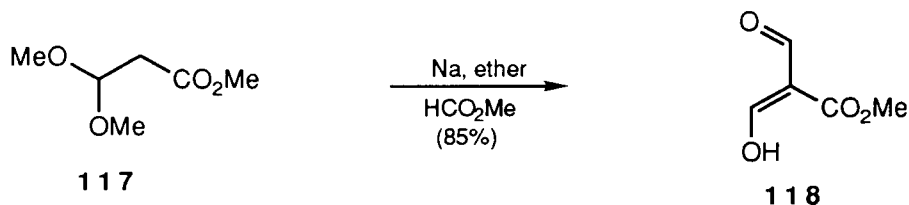

Scheme 22

The first step in the sequence entailed the known formylation of **117** in high yield using sodium sand and methyl formate (Scheme 22)³⁸ and gave the diformyl ester **118** upon acidic work-up. Hetero Diels-Alder reactions in which α,β -unsaturated carbonyl compounds serve as heterodienes are

characterized by "inverse electron demand". In these cycloadditions the electronic roles of the addends are reversed compared to the normal Diels-Alder reaction. The introduction of an electron-withdrawing group at the α -position of the α,β -unsaturated carbonyl compound would be expected to lower the LUMO energy, and therefore increase the reactivity of such a heterodiene.³⁹ In fact, the hetero Diels-Alder⁴⁰ reaction of **118** with ethyl vinyl ether (**119**), an electron-rich diene, afforded dihydropyran **120** in good yield. Oxidation of **120** with pyridinium dichromate (PDC) in the presence of powdered molecular sieves and anhydrous acetic acid⁴¹ gave **121** in higher than 90% yield. Finally, elimination of ethanol from **121** catalyzed by trifluoroacetic acid afforded the desired pyranone **116** (Scheme 23).

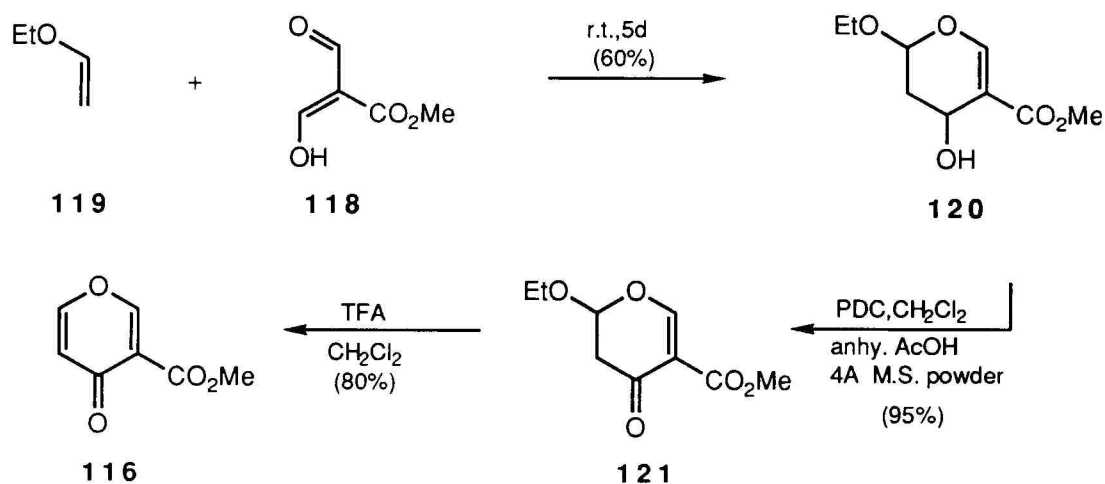

Scheme 23

3-Carbomethoxy-4-pyranone (**116**) reacted cleanly with 2-ethoxy-1,3-butadiene (**102**) at 200°C in a pressure tube, yielding the Diels-Alder adduct **122** in 85% yield. Epoxidation of **122** using *m*-chloroperbenzoic acid (*m*-CPBA) in the presence of ethanol²⁸ afforded a mixture of alcohols **123** and **124** in a ratio of ca 2.5:1, which were separated by flash column

chromatography. An X-ray crystallographic analysis of **124** elucidated the configuration of alcohols **123** and **124** as well as the regiochemistry of Diels-Alder adduct **122** as shown in Scheme 24. The ORTEP of **124** is shown in Figure 5. The relatively low selectivity for formation of **123** is attributed to the near planarity of the A ring of the bicyclic Diels-Alder adduct **122** which results in a low degree of curvature to this *cis* fused structure. In order to avoid complications from the free hydroxyl, alcohol **123** was protected as its 2-(trimethylsilyl)ethoxymethyl (SEM) ether to give **111**.

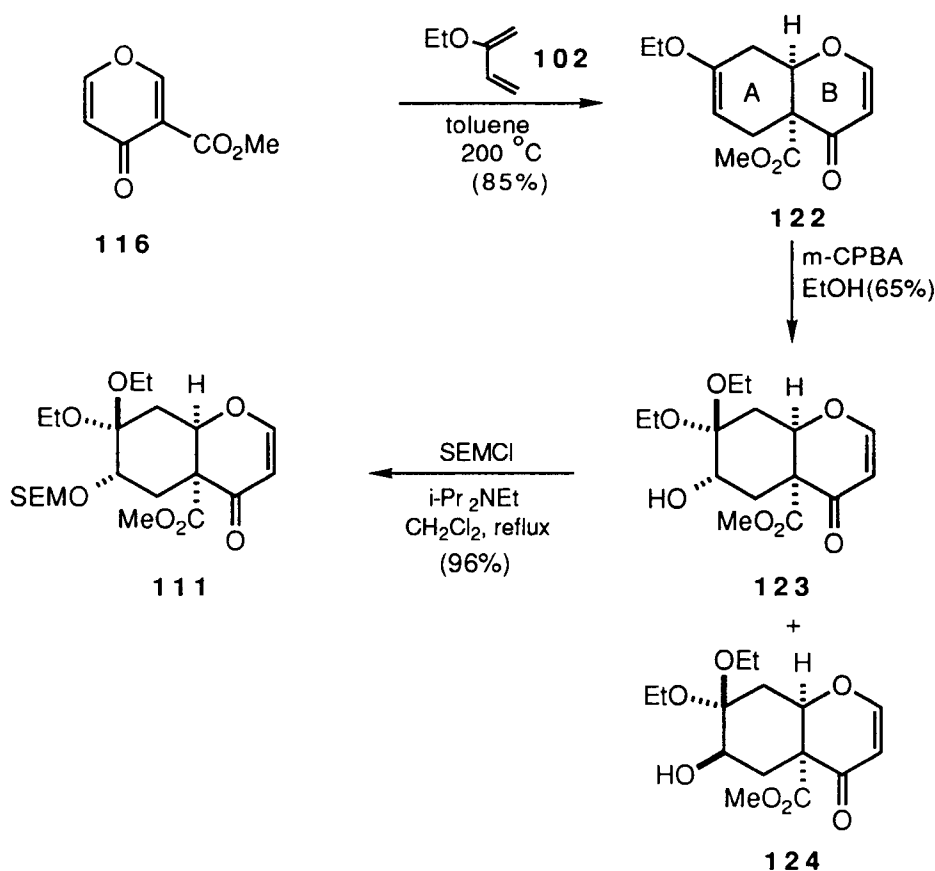

Scheme 24

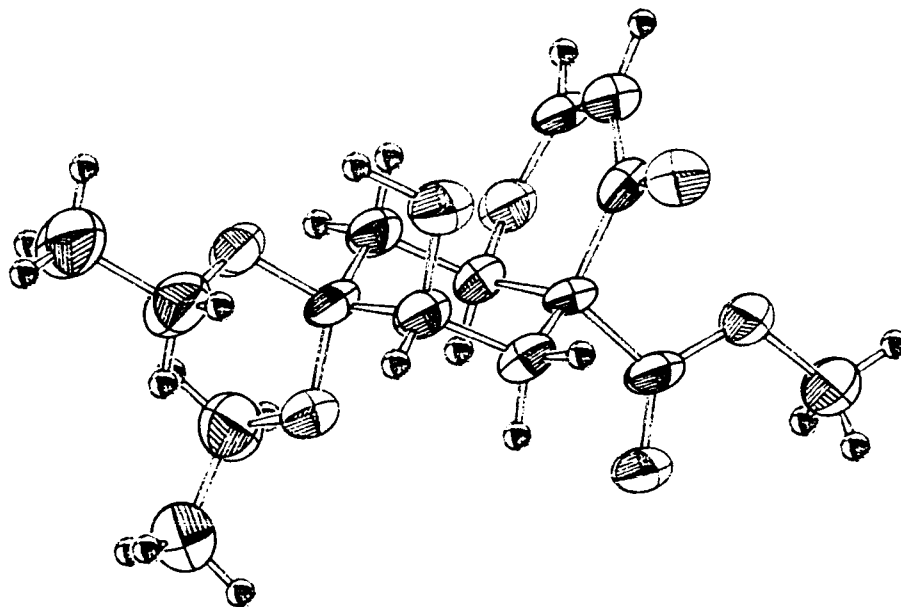
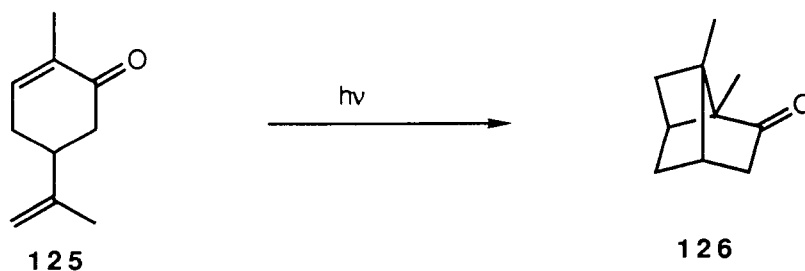

Figure 5 : ORTEP of 124

The [2+2] photoaddition of α,β -unsaturated ketones to olefins and acetylenes has been known since 1908 when Ciamician reported conversion of carvone (**125**) to carvone camphor (**126**) upon exposure to Italian sunlight (Scheme 25).⁴² More recent work on the photoreaction has led to partial elucidation of the mechanism and to a fair ability to predict the stereo- and regiochemistry of addition. The generally accepted mechanism is outlined in Figure 6.⁴³ In brief, the α,β -unsaturated ketone moiety E absorbs a quantum of light and is excited ($n \longrightarrow \pi^*$) to a singlet state S_1 , which undergoes intersystem crossing to the triplet state T_1 . The T_1 triplet state of E then interacts reversibly with a molecule of alkene A to give an exciplex which can lead to [2+2] product EA via either a concerted or a diradical pathway.



Scheme 25

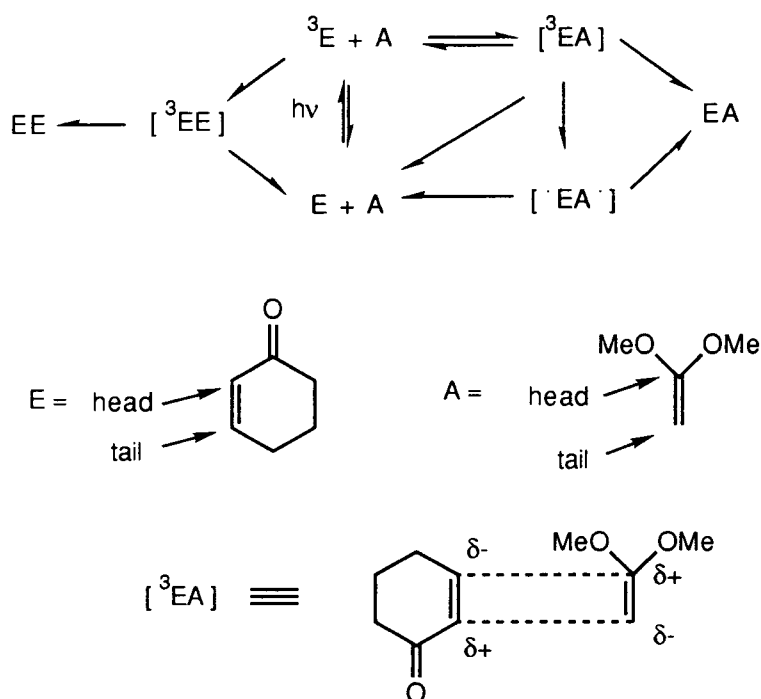
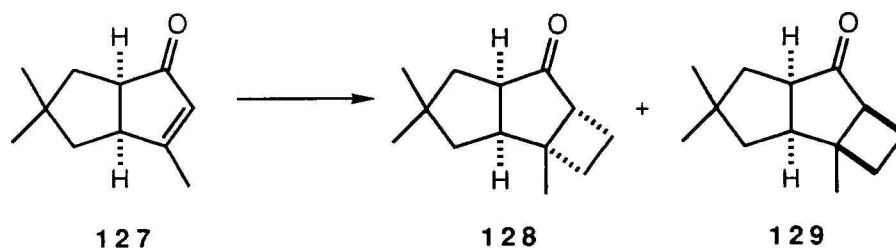

Figure 6 : Regiochemistry of [2+2] photoaddition of Cyclohexenone with 1,1-Dimethoxyethylene

The regiochemistry of addition is controlled largely by dipolar interactions in the exciplex, although solvent polarity is known to play a role. For example, an exciplex of cyclohexenone and ketene dimethyl acetal would have the molecular orientation shown in Figure 6. The polarity of the α,β -unsaturated ketone in the excited state is the opposite of its ground state polarization. Thus, this exciplex would be expected to give the "head to tail" product. The stereochemistry of [2+2] photoaddition is influenced by the

polarity of the alkene and by the presence or absence of a substituent on the β -carbon of the enone. Thus, while electron-rich olefins such as ketene dimethyl acetal yield a preponderance of *trans*-fused product upon addition to unsubstituted enones, the presence of a β -methyl group in 3-methylcyclohex-2-enone leads exclusively to *cis*-fused product with ketene dimethyl acetal.⁴⁴ The use of alkynes such as acetylene is known to lead to exclusive formation of the *cis*-fused photo adduct.⁴⁵ The photochemical addition of alkene partners to *cis*-fused bicyclic enones gives tricyclic products possessing the *cis-anti-cis* configuration. For example, addition of ethylene to **127** led to a 75:8 ratio of **128** to **129** (Scheme 26).^{46,47}



Scheme 26

Substituents at the α -carbon of conjugated enones have little effect in photoadditions to cyclopentenone systems, but they prevent or dramatically retard photoadditions to cyclohexenone.⁴⁸ This has been attributed to a facile conversion of triplet cyclohexenone to a vibrationally excited, twisted ground state.⁴⁹ Such a process is less accessible to the corresponding cyclopentenone. In contrast to 2-methylcyclohex-2-enone, 6-methyluracil derivative **130** underwent efficient cycloaddition to isobutylene (Scheme 27).⁵⁰ A possible explanation for this result involves the increased tendency of

uracil derivatives to maintain planarity and thus deprive the uracil excited state of energy-wasting deactivation via a twisted ground state.

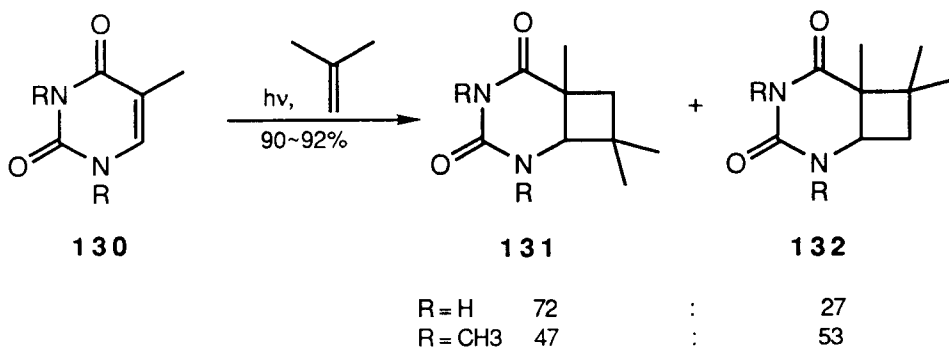

Scheme 27

Addition of a photopartner to the A-B framework of **111** was anticipated to occur from the α or exo face yielding the cyclobutene **133** as a major product.^{46,51} A solution of **111** in acetone was saturated with a slow stream of acetylene and then irradiated with a 450 Watt medium-pressure Hanovia mercury lamp through a Pyrex filter. This yielded a mixture of cyclobutenes **133** and **134** in a ratio of 10:1, which was separated by flash column chromatography (Scheme 28).

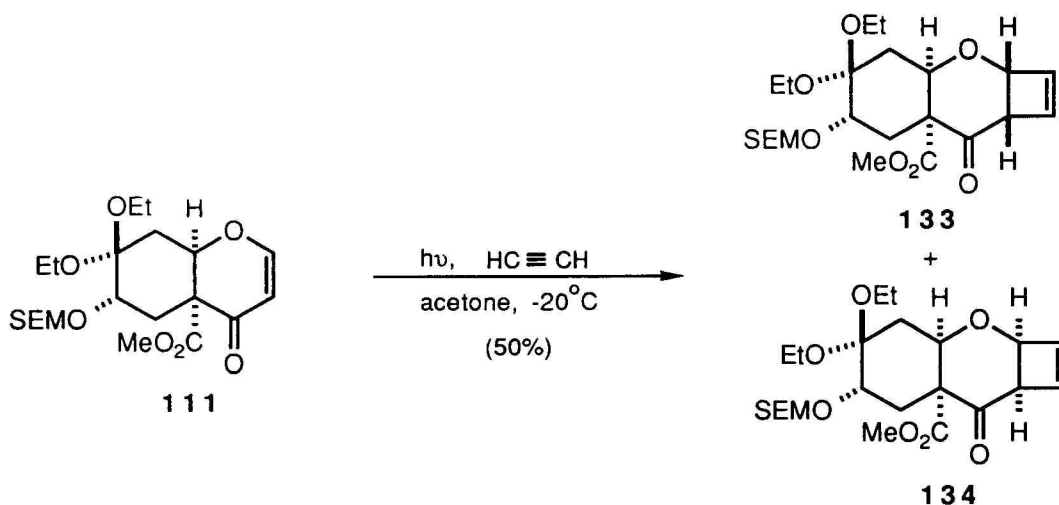

Scheme 28

Solvolytic rearrangement of a cyclobutenyl carbinol in a bicyclo[4.2.0] skeleton to a cyclopenten-4-ol in a bicyclo[3.2.1] system is represented schematically as **135** \longrightarrow **136** (Figure 7). It was intended to use this rearrangement to convert an oxabicyclo[4.2.0]octene system to the oxabicyclo[3.2.1]octene framework of the trichothecenoids. Expansion of the cyclobutene to a cyclopentene would be driven by release of the high strain energy of the four-membered ring (28.5 Kcal/mol).⁵² First, **133** was converted to the methyl carbinol **137** and exposure of **133** to either methylmagnesium bromide or methyllithium at 0°C or at -78°C respectively produced **137** in good yield (Scheme 29).

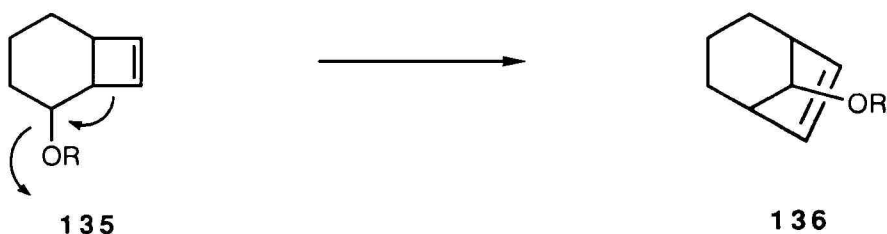
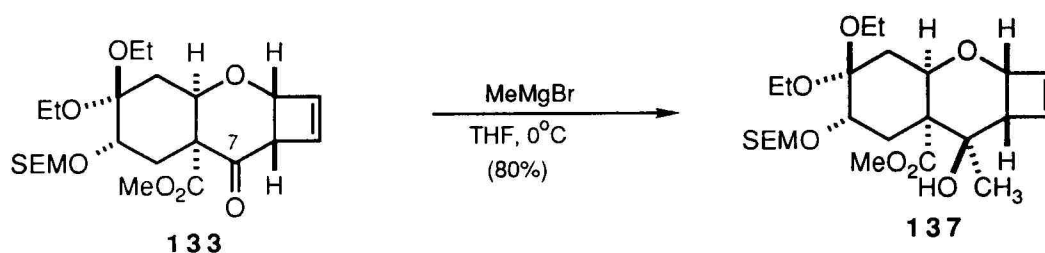

Figure 7 : Solvolytic Rearrangement of a Bicyclo[4.2.0]oct-7-ene to a Bicyclo[3.2.1]oct-2-ene



Scheme 29

The high stereoselectivity of attack of the Grignard reagent at the ketone carbonyl (C7) of **133** can be rationalized by both steric and stereoelectronic factors. The α -face of the ketone is sterically more accessible to the Grignard reagent than the β -face. Further, α attack by the Grignard reagent is in accord with the Cieplak effect. In 1981, Cieplak proposed a hyperconjugative stereoelectronic effect to explain the selectivity of nucleophilic addition to ketones.⁵³ He postulated that the critical factor determining the stereoselectivity of the reaction is a low-lying vacant σ^* orbital in the transition state associated with the σ bond being formed. Electronic delocalization into that orbital will stabilize the transition state and thereby enhance the reaction rate. According to this postulate, stereoselectivity is controlled by the donor ability of the C-C bond and the C-H bond in hyperconjugative interactions with the developing σ^* orbital. The Baker-Nathan effect has established that the relative donor ability of a C-H bond is better than a C-C bond.⁵⁴ Thus, the Cieplak effect argues that an axial approach is preferred over an equatorial approach to the carbonyl since the C-H bond contributes a greater hyperconjugative stabilization of the σ^* orbital than the C-C bond (Figure 8). The combination of steric and stereoelectronic factors predict β -alcohol **137** as the major product from **133** and this is, indeed, the case. In fact, none of the epimeric C-7 alcohol was detected.

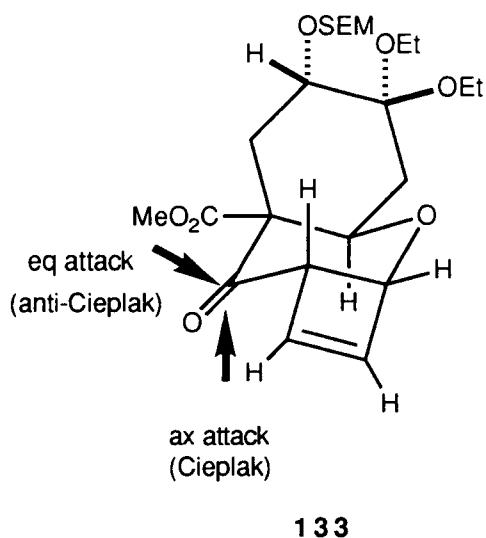

Figure 8 : Approach Trajectories of a Nucleophile to the Ketone Carbonyl of **133**

The configuration of the tertiary alcohol at C7 was confirmed to be β by a difference n.O.e. (nuclear Overhauser effect) experiment. Irradiation of the methyl group at C7 induced an enhancement of peak height of the vinyl hydrogen at C5 (3.5%) and the ring angular hydrogen at C1 (5.2%). As shown in the conformational representation of **137**, the 7α methyl group is situated spatially in close proximity to hydrogens at C1 and C5 (Figure 9).

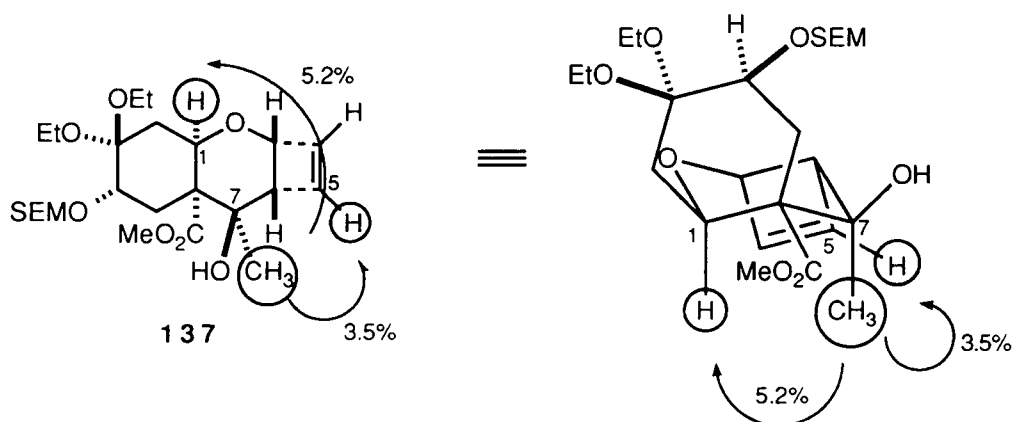
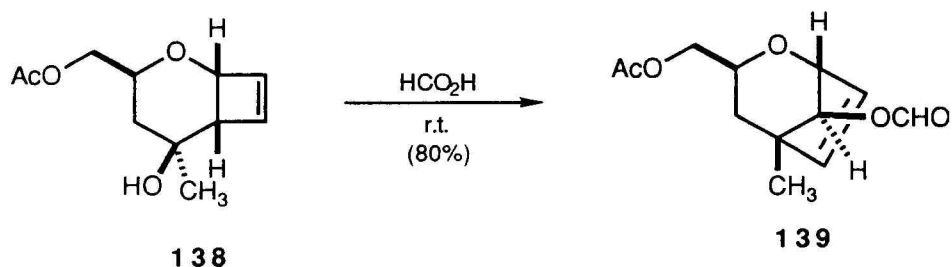

Figure 9 : Nuclear Overhauser Enhancement of H1 and H5 Upon Irradiation of the C7 Methyl Group

Although solvolytic ring enlargement of cyclobutyl carbinols is well precedented,⁵⁵ few examples involving a cyclobutene^{51,56} appear to have been described. However, one example of this rearrangement has been reported in a 4-oxa system similar to **137**, in which acid-catalyzed rearrangement of **138** to **139** was claimed by Fetizon (Scheme 30).⁵⁶



Scheme 30

Hess found that an 80:20 mixture of tosylates **140** and **141** rearranged to give an 80:16:4 mixture of **142**, **143** and **144** upon refluxing in acetic acid (Scheme 31).⁵⁷ Although **140** and **141** were not solvolyzed separately, a plausible assumption is that **142** arises from **140** via synchronous shift of the 1,8 bond and displacement of tosylate. The resulting carbonium ion was trapped by acetic acid from the endo face, presumably due to a stereoelectronic effect in which the developing positive charge is partially delocalized into the pi system of the ethylene bridge.⁵⁸ Correspondingly, **143** and **144** arise from a synchronous shift of the 1,6 bond of **141** with displacement of tosylate, followed by trapping of the resulting allylic cation with acetic acid.

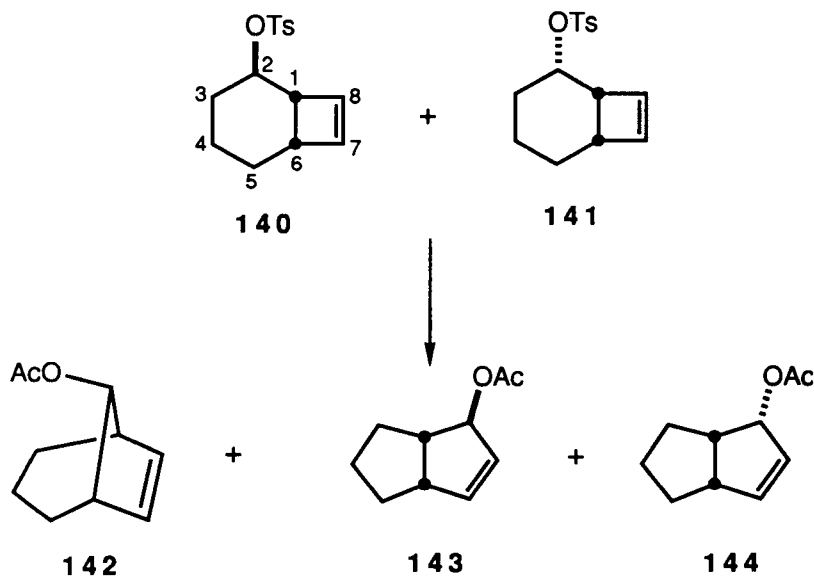

Scheme 31

The results obtained upon solvolysis of pure isomers **145** and **147** containing a saturated bicyclo[4.2.0]system supports this mechanistic picture (Scheme 32). For example, solvolysis of **145** gave **146** as the sole product whereas solvolysis of **147** furnished only **148**.⁵⁹ Thus, the equatorial mesylate rearranges by migration of bond a to give a bicyclo[3.3.0]octane ring system whereas the axial mesylate rearranges by migration of bond b to give a bicyclo[3.2.1]octane ring system. The products of these specific rearrangements are in good agreement with a concerted mechanism which requires an antiperiplanar alignment of the migrating C-C bond and the leaving group.

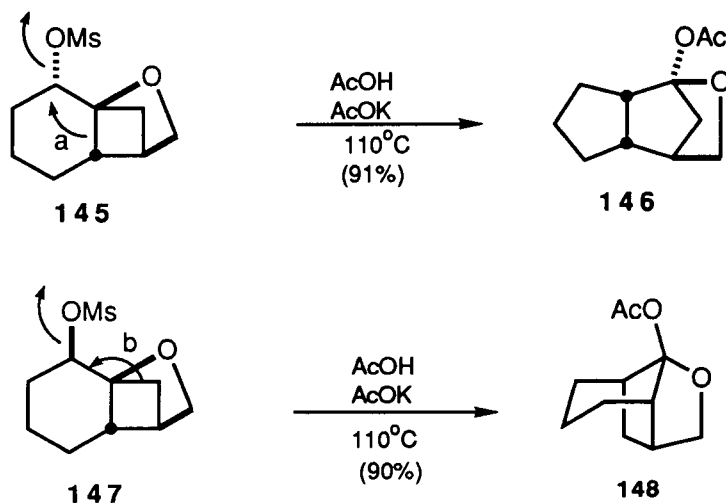

Scheme 32

Based on the precedent seen in the rearrangement of **147** to **148** it was hoped that transformation of **137** to the trichothecene nucleus could be effected under acid-catalysis. However, attempts to effect rearrangement of **137** to **150** using 98% formic acid or *p*-toluenesulfonic acid in aqueous acetone failed. An attempt to convert the trifluoroacetate **149**, which was prepared from **137** and trifluoroacetic anhydride, into **150** via rearrangement was also unsuccessful. These reactions yielded only the ketone **151** or **152** in which the ketal had been hydrolyzed (Scheme 33). An alternate substrate, tricyclic compound **155** was prepared from Diels-Alder adduct **122** via ketalization with ethylene glycol, photoaddition with acetylene and addition of methyl lithium. Again acid treatment of **155** afforded no evidence of rearrangement but resulted only in ketal hydrolysis (Scheme 34).

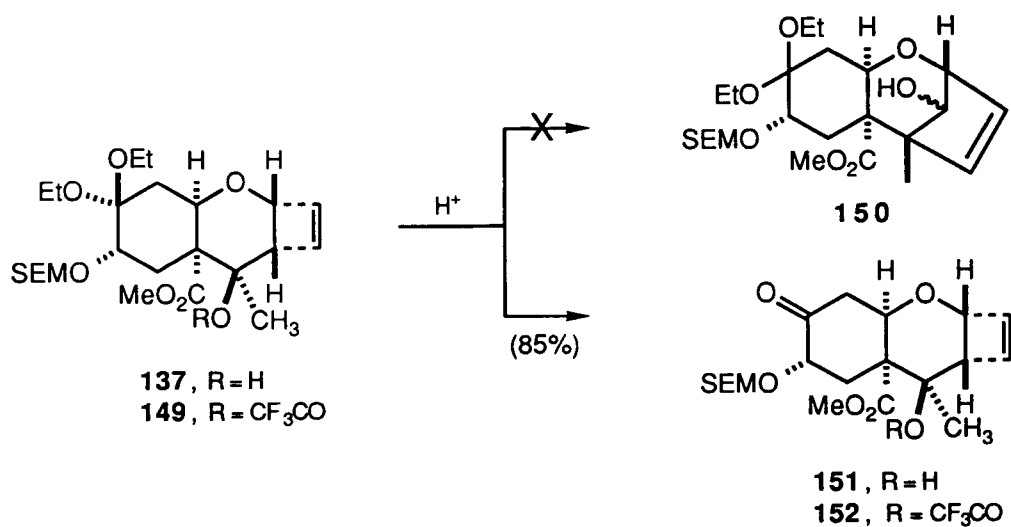

Scheme 33

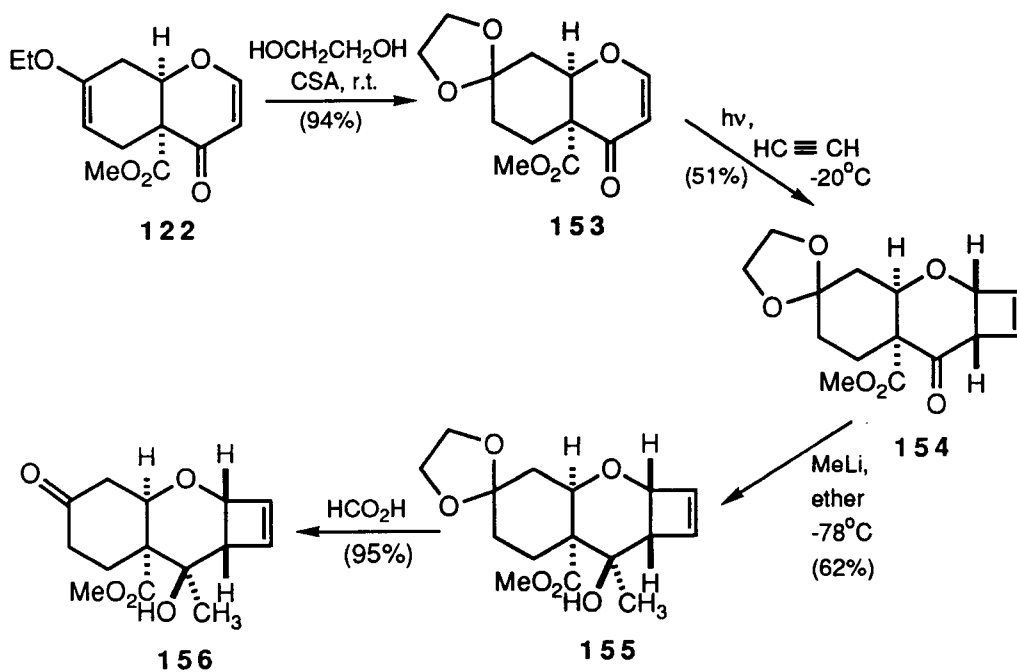

Scheme 34

A plausible explanation for the failure of these cyclobutenyl carbinols to undergo rearrangement is that the migrating C5-C6 bond of **137**, **149**, and **155** is not well aligned, i.e. antiperiplanar, to the leaving hydroxy group, a factor which would make the rearrangement unfavorable.

In order to compare the efficacy of sp^3 hybridized carbon in ring enlargement of our trichothecene precursor with that of sp^2 carbon, solvolytic rearrangement of the cyclobutanylcarbinol **158** was examined. The olefin of the cyclobutene in **133** was hydrogenated to afford **157** in almost quantitative yield, and the latter was reacted with methyllithium to give tertiary alcohol **158**. However, treatment of **158** with formic acid again yielded only **159** in which the ketal was hydrolyzed. No product from ring enlargement was observed (Scheme 35).

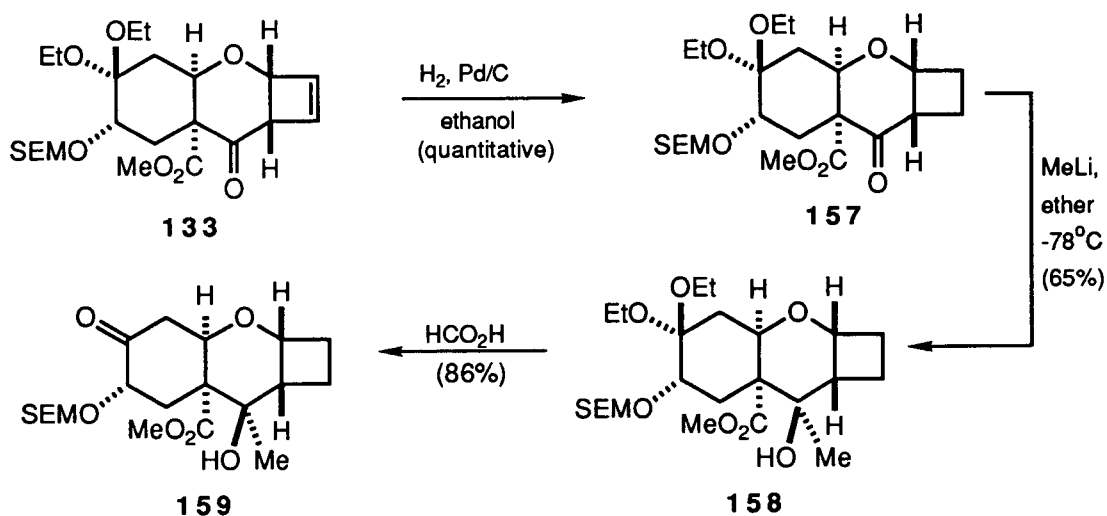

Scheme 35

Reasoning that the tertiary alcohol terminus towards which migration was desired might be the source of our problem, we next considered other functionality at this site. For example, transformation of the ketone carbonyl of **133** into an exo methylene group would provide an sp^2 terminus whereas conversion of **133** to an exo oxirane would afford a precursor possessing ring strain which could assist rearrangement.

Treatment of **133** with methylenetriphenylphosphorane under conventional conditions⁶⁰ yielded unreacted starting material and a small amount of a fragmentation product **161** resulting from a retro-Dieckmann condensation (Scheme 36). An alternative methylenation procedure described by Lombardo using zinc, dibromomethane, and titanium tetrachloride,⁶¹ when performed on **133**, gave a complex mixture of products in which **160** was not present. Attempted epoxide formation from **133** with dimethylsulfonium methylide⁶² also gave the retro Dieckmann product **161** rather than the desired oxirane **162** (Scheme 37).

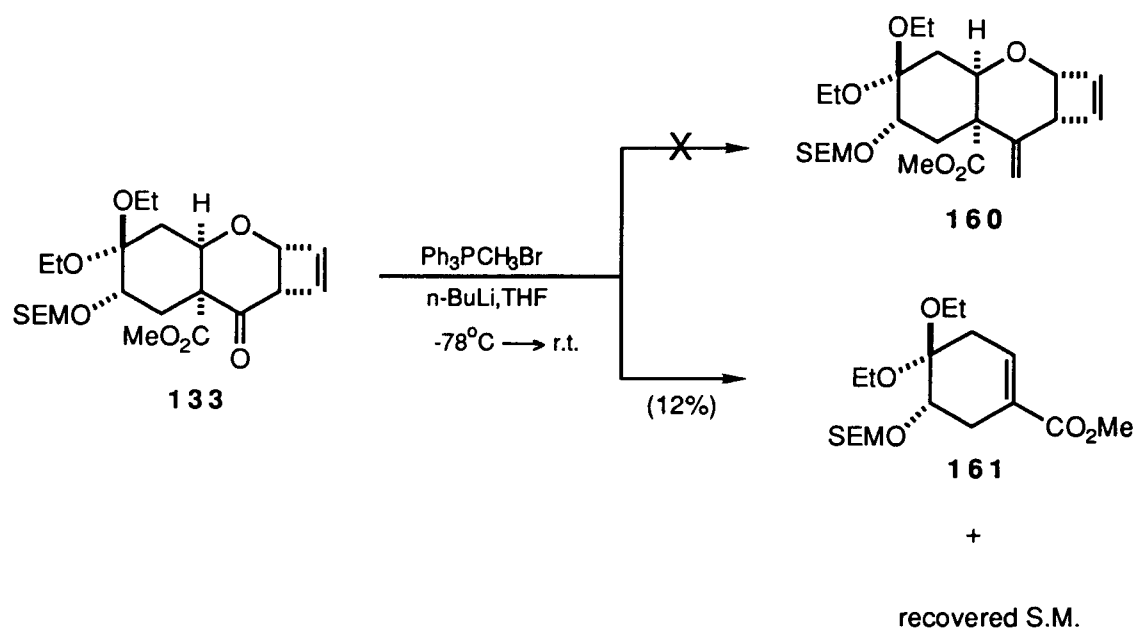

Scheme 36

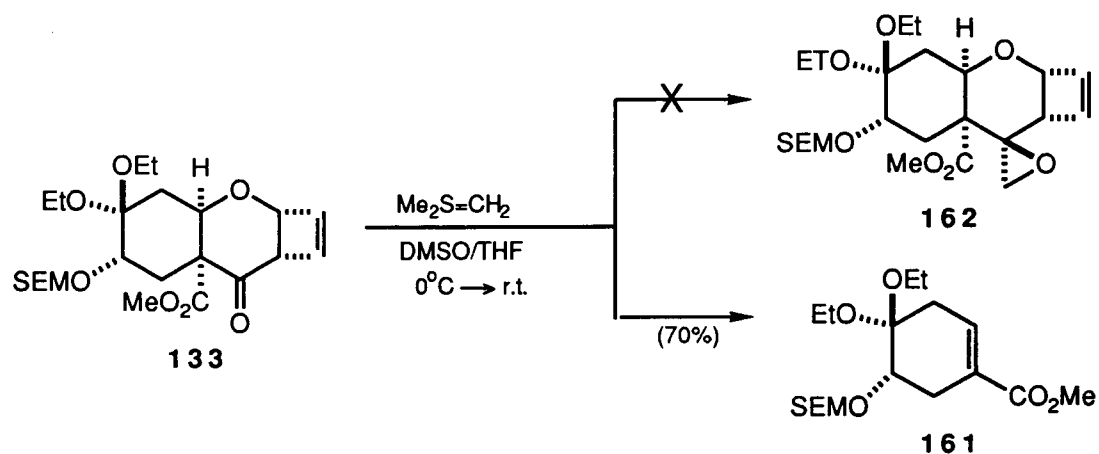

Scheme 37

A rearrangement discovered by Cargill⁶³ has been shown to be a useful method for converting a bicyclo[4.2.0]octene system to the bicyclo[3.2.1]octene framework and we therefore decided to examine the application of this process for constructing the oxabicyclo[3.2.1]octene system present in the trichothecene nucleus. An example of Cargill rearrangement is shown in Figure 10 where 6-methylbicyclo[4.2.0]oct-7-en-2-one (**163**) undergoes transformation in the presence of an acid catalyst to 1-methylbicyclo[3.2.1]oct-6-en-8-one (**166**).⁶⁴ The mechanism of this rearrangement is thought to involve initial migration of the C1-C6 bond of **163** to the C2 center via the protonated intermediate **164** affording **165**. The intermediate **165** undergoes further bond reorganization, as shown in Figure 10, to afford the bicyclo[3.2.1]octene system of **166**.

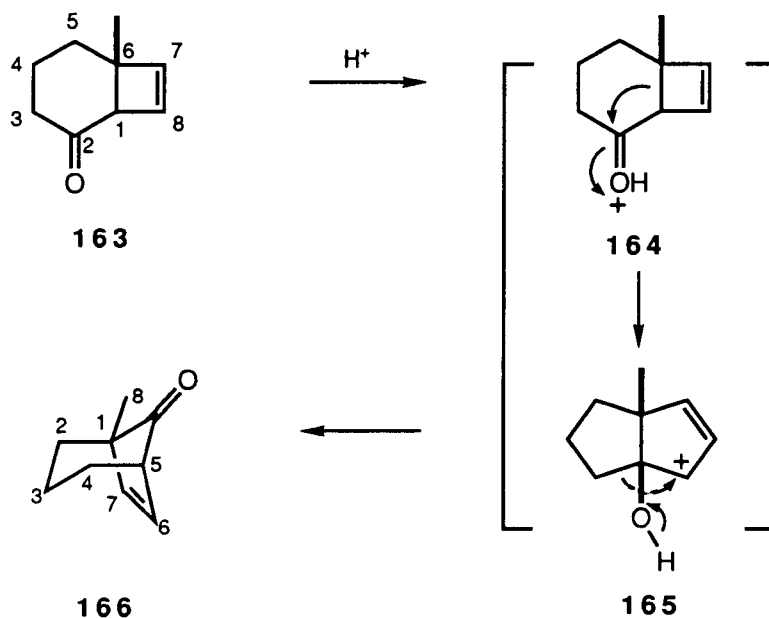
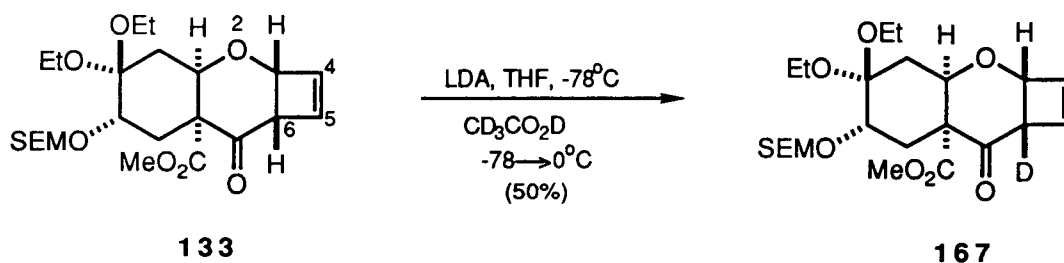

Figure 10 : Cargill Rearrangement of 6-Methylbicyclo[4.2.0]-oct-7-en-2-one (**163**) to 1-Methylbicyclo[3.2.1]-oct-6-en-8-one (**166**)

In order to apply this strategy to **133**, introduction of a methyl group at C6 is necessary prior to the rearrangement. Although deuterium exchange of the angular hydrogen in bicyclo[4.2.0]octene systems is known,⁶⁵ the corresponding alkylation at this ring position is not preceded. Therefore, prior to undertaking attempts at methylation at C6 of **133**, enolization of the ketone carbonyl was examined. Exposure of **133** to lithium diisopropylamide, followed by addition of tetradeuterioacetic acid, resulted in a 50% incorporation of deuterium into **167** at C6 (Scheme 38). By contrast, neither methylation nor phenylsulfenylation at this site in **133** could be accomplished and only starting material was recovered after neutralization of the enolate.



Scheme 38

An alternative approach to incorporating a methyl group at C6 of **133**, would be through the use of 3-carbomethoxy-5-methyl-4-pyranone (**169**) as the starting material. A Diels-Alder reaction of 2-ethoxy-1,3-butadiene (**102**) with **169**, followed by photoaddition with acetylene (**170**) would lead to **168**, the methylated analogue of **133** (Scheme 39).

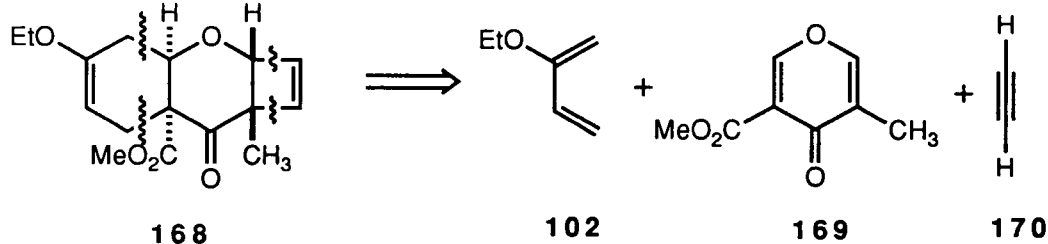

Scheme 39

The methyl substituted 4-pyranone **169** was prepared by a procedure analogous to that used for 3-carbomethoxy-4-pyranone (**116**). Hetero Diels-Alder reaction of **118** with ethyl 1-propenyl ether **171** (mixture of *cis* and *trans* isomers) afforded **172** as a mixture of four diastereomers in 70% yield. Oxidation of **172** with pyridinium dichromate, followed by acid-catalyzed elimination of ethanol, resulted in **169** (Scheme 40).

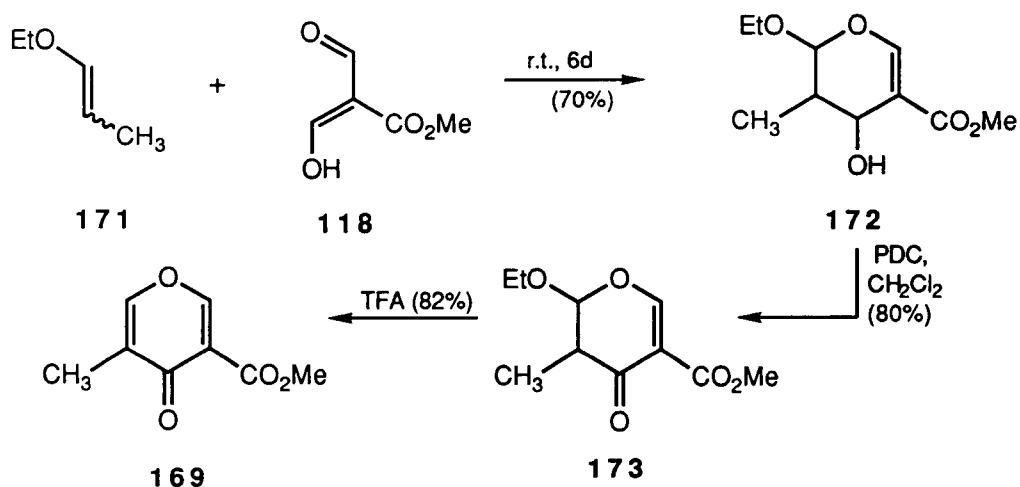

Scheme 40

The reaction of **169** with 2-ethoxy-1,3-butadiene (**102**) afforded the bicyclic adduct **174**, further illustrating the utility of a 4-pyranone-3-carboxylate as a Diels-Alder dienophile. At this point it was decided to forego introduction of the hydroxyl group at C8 of the trichothecene nucleus since its presence is not critical for testing the BC ring construction. Enol ether **174** was therefore converted directly to the corresponding ketal **175** by stirring in ethylene glycol with a small amount of camphorsulfonic acid. Irradiation of **175** in the presence of acetylene with a Hanovia 450 Watt mercury lamp at -20°C yielded the photoadduct **176** in 44% yield based on recovered starting material (Scheme 41).

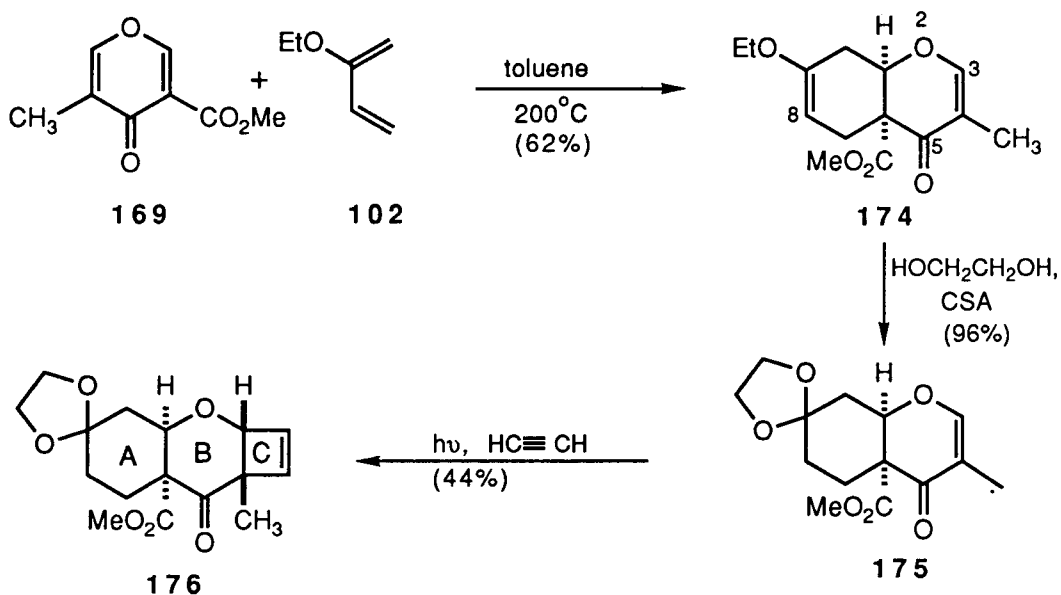

Scheme 41

The stereochemistry of the BC ring fusion in **176** was determined by a series of difference nuclear Overhauser experiments (Figure 11). Irradiation of the signal due to Hc caused the enhancement of signals due to the protons Ha and Hb by 3.7 and 3.4%, respectively. In addition, irradiation of Ha induced a 3.7% peak enhancement of Hc. These experiments define a stereochemical relationship between the cyclobutene and the A ring of **176** which is anti.

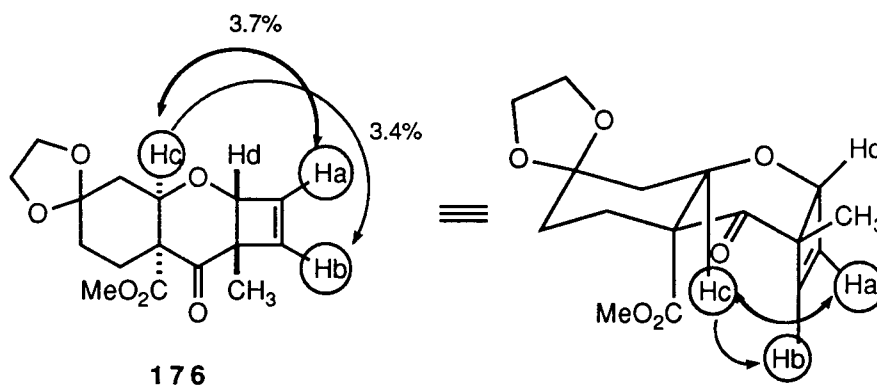
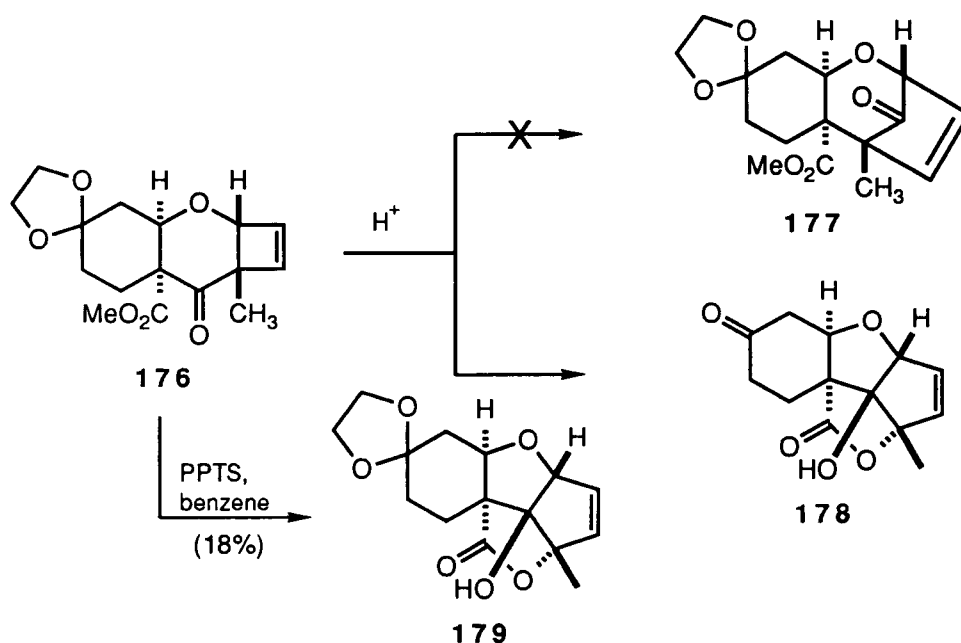

Figure 11: Nuclear Overhauser Enhancement of Ha and Hb Upon Irradiation of Hc

Having developed a stereocontrolled route to cyclobutene **176**, the Cargill rearrangement of this material was next examined. To this end, **176** was exposed to a variety of Bronsted and Lewis acids, including *p*-toluenesulfonic acid, boron trifluoride etherate, and aqueous 2N sulfuric acid. In virtually all cases it was found that acidic treatment of **176** gave the interesting product **178**, often in high yield (23~80%) (Scheme 42).



Scheme 42

The structure of **178** was unambiguously determined by X-ray crystallography. An ORTEP is shown in Figure 12. The proposed mechanism of the conversion of **176** to **178** is shown in Scheme 43. The first bond migration of the Cargill rearrangement which connects C3 with C7 occurs rapidly but is followed by intramolecular trapping of the resulting tertiary, allylic carbocation by the carbomethoxy group of **181** rather than by the desired pinacol rearrangement of C8 to C6. The carbomethoxy group of **181** is located in an ideal position on the endo face of **181** to interrupt the second

migration, and the relatively unstrained conformation of lactone **178** reflects the favorable geometry for this participation by the angular ester group.

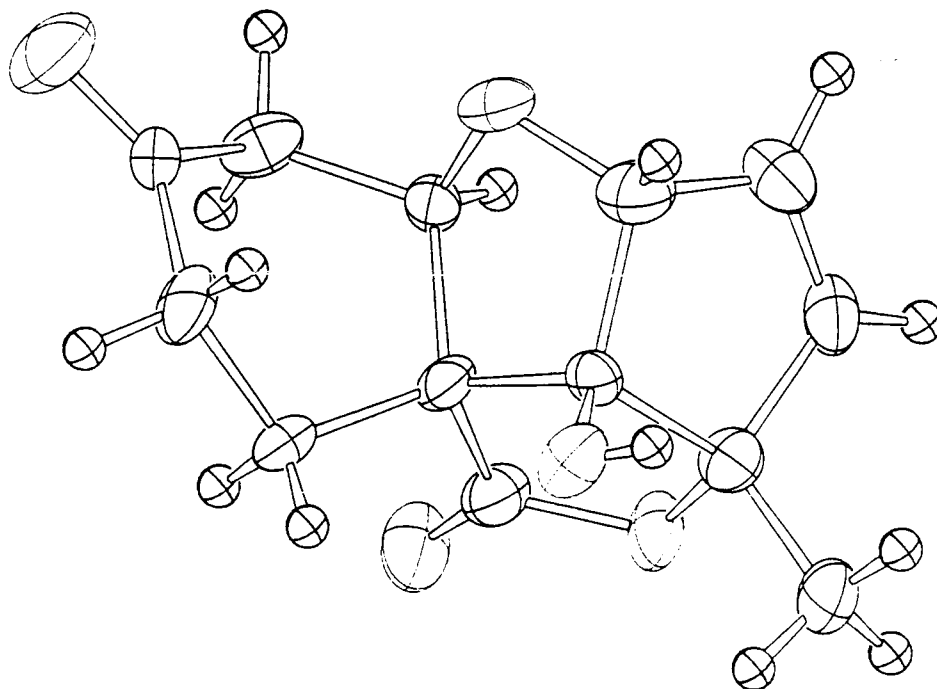
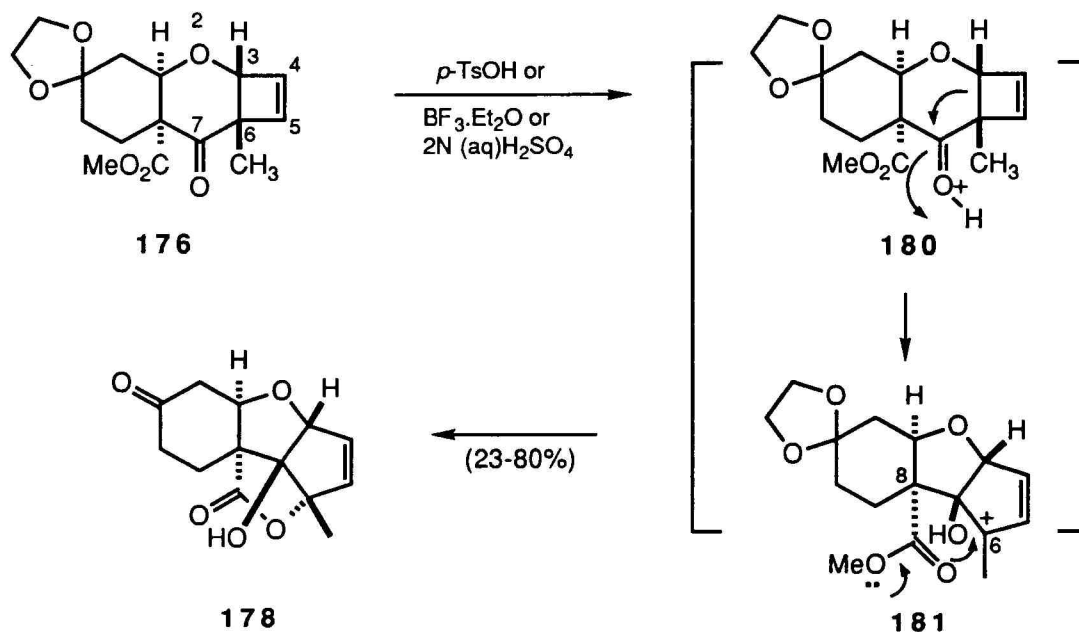
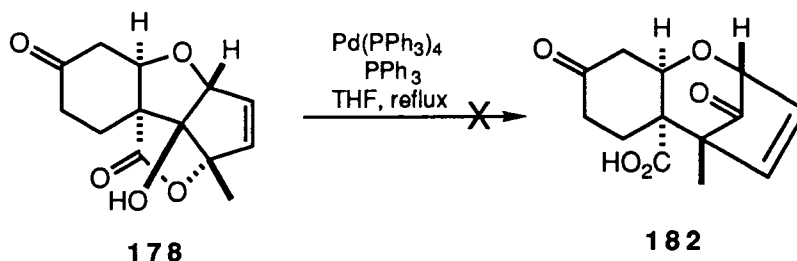

Figure 12 : ORTEP of 178



Scheme 43

It was hoped that the Cargill rearrangement might be continued from **178** towards the desired trichothecene skeleton, eg **182**, using a palladium catalyst since it is well known that Pd(0) forms π -allyl complexes with allylic acetates. In principle, Pd(0) could regenerate the equivalent of allylic carbocation **181** through formation of a π -allyl complex.⁶⁶ Palladium-catalyzed alkylation of allylic acetates usually results in net retention of configuration in the product since formation of the intermediate π -allyl complex occurs with inversion and nucleophilic alkylation of the complex also occurs with inversion.⁶⁷ The double inversion of this sequence is, of course compatible with the transformation of **178** to **182**. However, no rearrangement of the very stable lactone **178** could be induced with Pd(PPh₃)₄, the only result being complete recovery of starting material (Scheme 44).



Scheme 44

We were nevertheless encouraged by the fact that, in the conversion of **176** to **178**, the first step of our planned rearrangement had taken place. It was hoped that some appropriate variation of this strategy could circumvent interception of **181** by the angular ester grouping and thus lead to completion of the skeletal reorganization.

First, acid-catalyzed rearrangement of **176** was attempted in solvents such as methanol and glacial acetic acid (Scheme 45). *p*-Toluenesulfonic acid catalyzed rearrangement of **176** in methanol resulted in a mixture of **178** and **183** in a ratio of 1:3, whereas treatment of **176** with glacial acetic acid alone yielded **184**, **185** and **186**. In all cases, C3 migration has occurred to yield the presumed allylic carbocation intermediate **181**. However, the allylic carbocation was again trapped internally by the carbomethoxy group at C6 to produce **178**, **184**, and **186** or was intercepted by intermolecular attack of solvent at C4 to produce the methyl ether **183** or the acetate **185**.

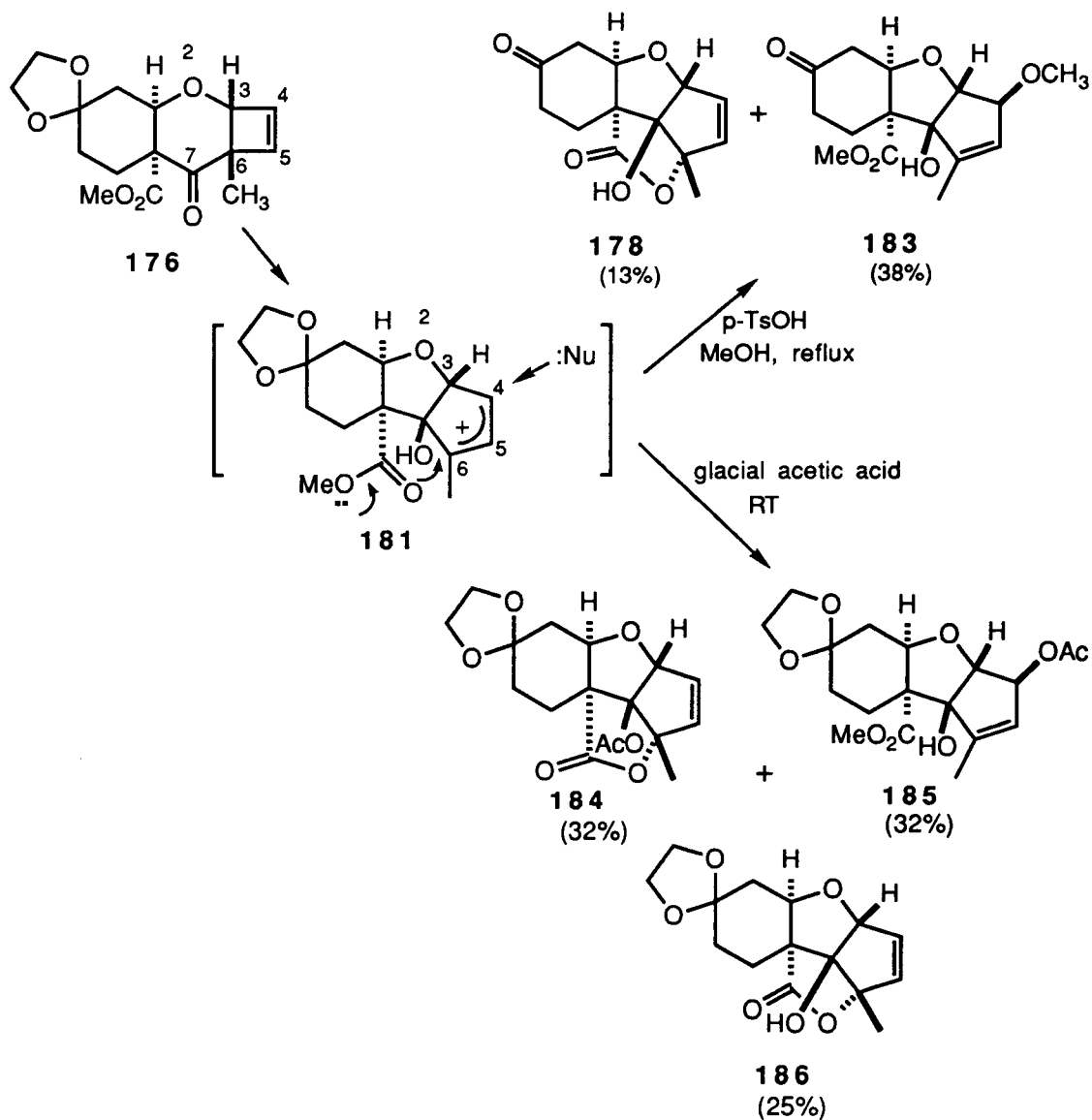

Scheme 45

The possibility that a base-catalyzed rearrangement of **185** could lead to the desired oxabicyclo[3.2.1]system was also considered (Scheme 46). However, treatment of **185** with sodium hydride was found to give ester **189** in good yield rather than **177**. This result is consistent with formation of alkoxide **187** which subsequently undergoes consecutive retro aldol fission via **188**. The expected byproduct **190** was not isolated from this reaction

perhaps due to the fact that this species may also be unstable in the presence of base.

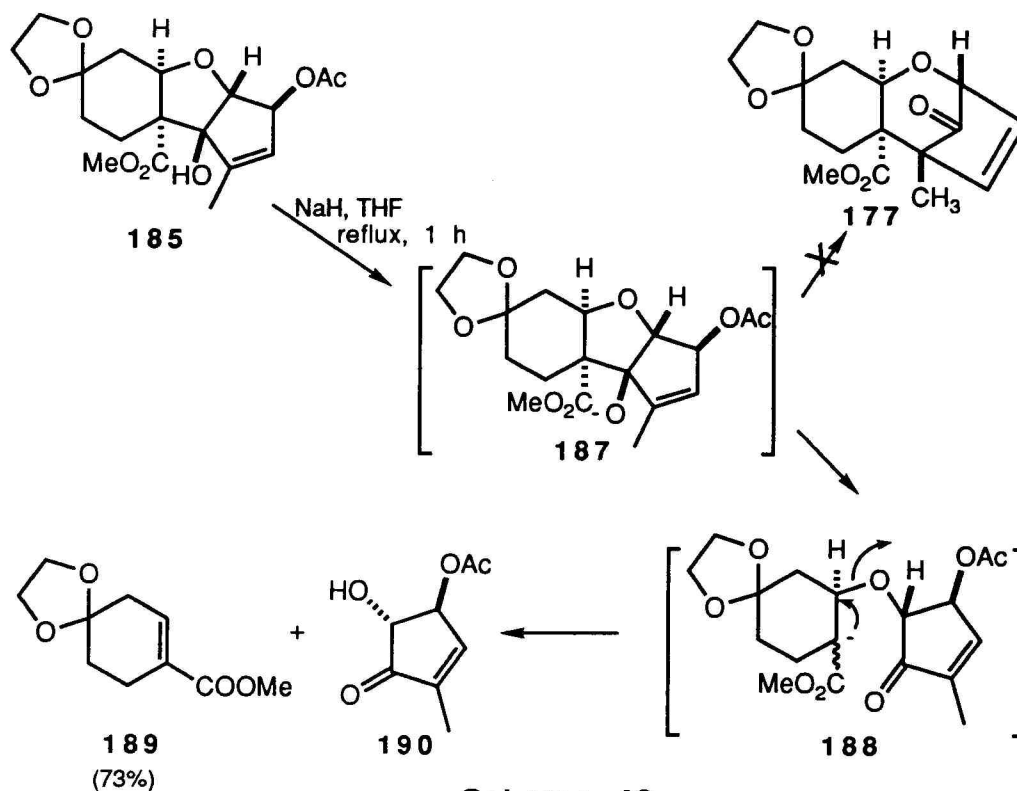

Scheme 46

An alternative tactic for circumventing formation of the γ -lactone **178** would entail conversion of the carbomethoxy function at C8 in **176** into a non-participating functional group before attempting the acid-catalyzed rearrangement. A methyl substituent at this position would obviously prevent interception of the allylic carbocation resulting from Cargill rearrangement of **176** and, although this simplification removes T-2 toxin (**1**), verrucarol (**4**) and other trichothecenes from our range of targets, many natural trichothecenoids contain a C8 methyl group. It was, therefore, decided to attempt conversion of the carbomethoxy group of **176** into a methyl group using Barton's deoxygenation procedure.⁶⁸ Reduction of **176** with lithium aluminum hydride

proceeded smoothly to afford the alcohol **191** in 85% yield. Selective thioacylation of the primary alcohol of **191** with thiocarbonyl diimidazole was unsuccessful, affording the thionocarbonate **193** rather than the desired imidazole derivative **192**. In contrast, reaction of **191** with phenyl chlorothionoformate (**194**)⁶⁹ gave the 2'-phenoxythiocarbonyl ester **195** in 59% yield. Surprisingly, treatment of **195** with tributyltin hydride under standard reduction conditions⁷⁰ resulted the formation of carbonate **197**. No evidence for the desired reduction product **196** was found (Scheme 47).

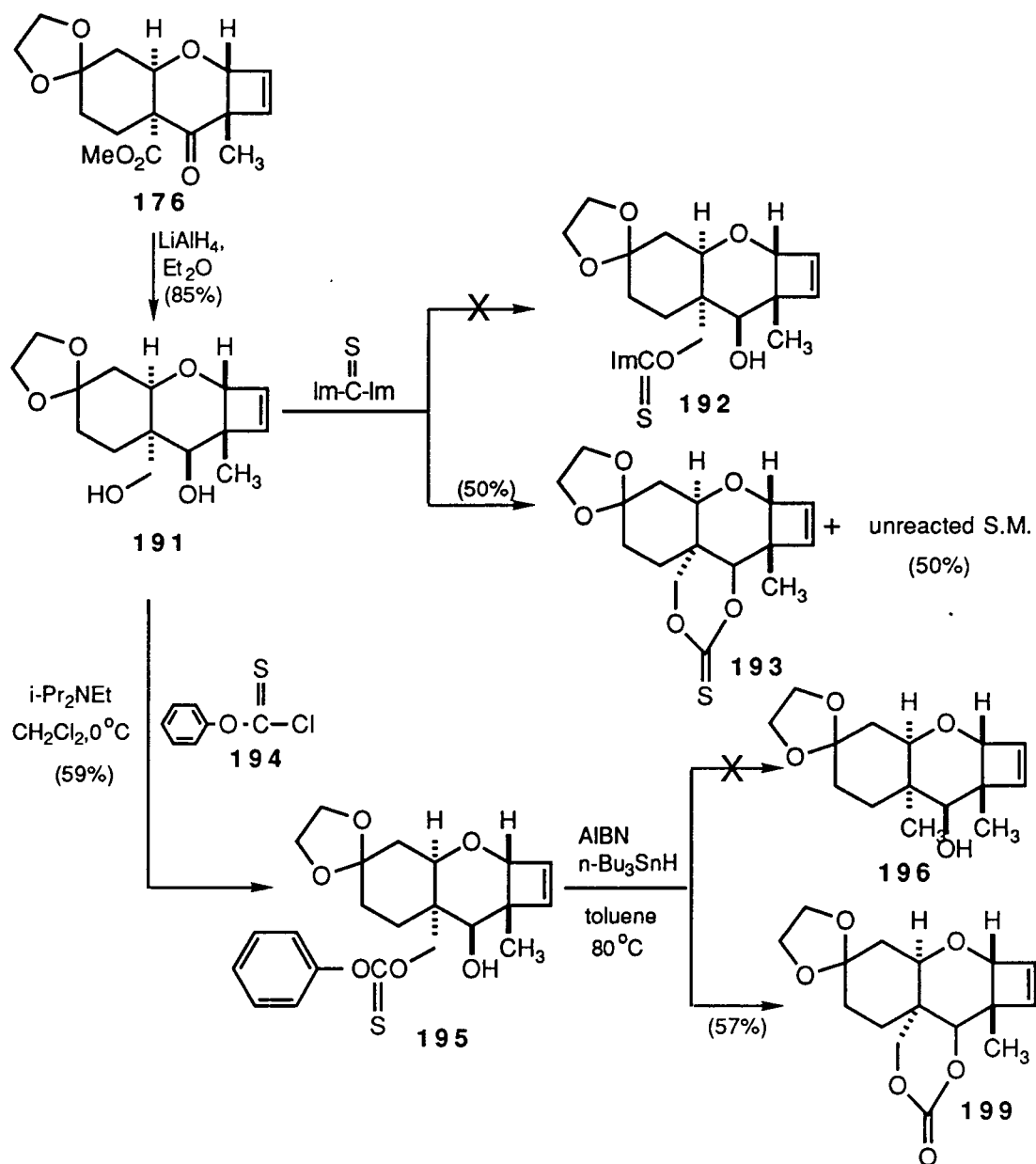

Scheme 47

In view of these unsuccessful attempts to remove the hydroxyl group from the C8 primary alcohol of **191**, an alternative plan involving protection of this functionality was explored. For this purpose the hydroxymethyl group of **191** was converted to its acetate **198** and to the benzyl ether **199** (Scheme 48). Oxidation of **198** and **199** with pyridinium dichromate afforded new substrates **200** and **201** on which rearrangement could be tested. It was

assumed that neither acetate **200** nor benzyl ether **201** would interfere with the rearrangement process previously interrupted at allylic cation **181** by the angular ester and that conversion to the desired oxabicyclo[3.2.1]octene system would ensue. However, to our surprise, treatment of both **200** and **201** with *p*-toluenesulfonic acid resulted in the formation of the tetracyclic ether **204**. It is evident from these results that the very favorable geometry for participation by the angular acetate in cation **202** and benzyl ether in **203** overrides all other factors which might encourage migration of C8 to C6.

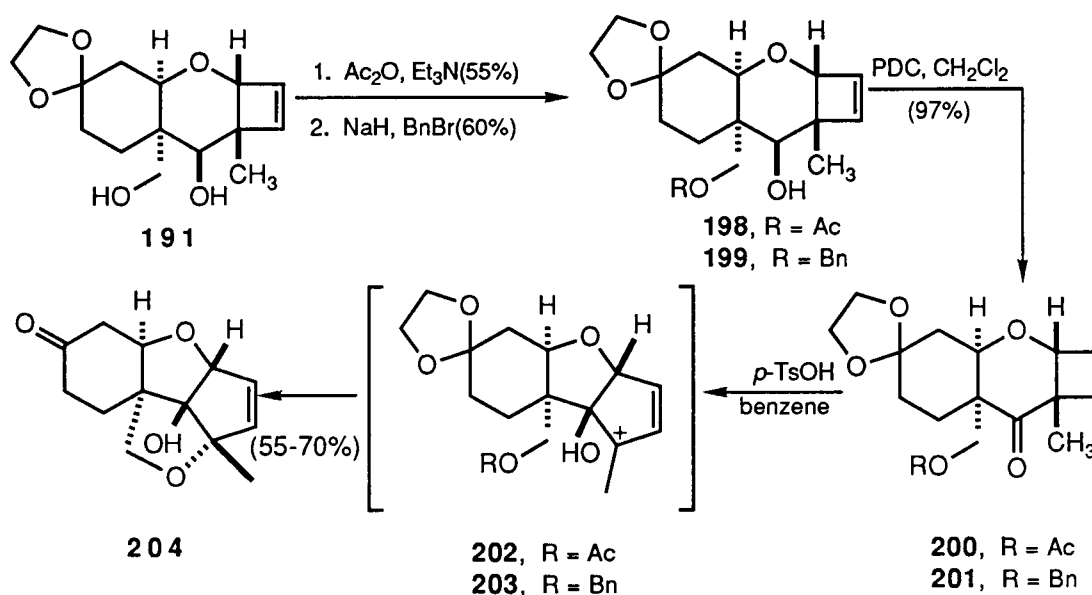

Scheme 48

Reasoning that a tosylate, being less nucleophilic than either an acetate or benzyl ether, would be less likely to intercept the allylic cation during rearrangement, the primary alcohol of **191** was selectively converted to its *p*-toluenesulfonate **205**. This was followed by oxidation with pyridinium dichromate to give ketone **206**. Treatment of this ketone again produced an unexpected result, for although the tosyl group in **206** did not participate in

rearrangement, the diene **208** resulting from elimination of a proton from cation **207** was the principal outcome (Scheme 49).

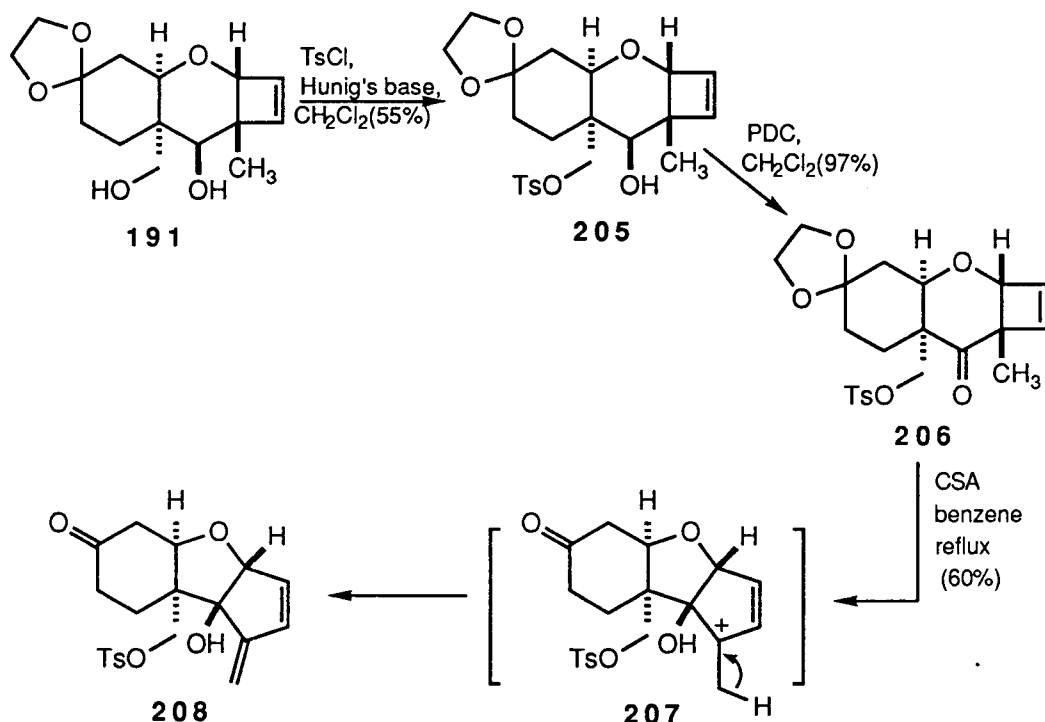

Scheme 49

It must be concluded from the failure of many attempts to effect the transformation of the linear, fused tricyclic structures **176**, **200**, **201** and **206** to the bridged framework found in the trichothecenes that Cargill-type rearrangement in these systems is opposed by factors that are poorly understood. There is no doubt that the first step of the rearrangement, driven by relief of strain in the cyclobutene, occurs rapidly. The second step, although it has no direct precedent, would be a variant of the pinacol rearrangement, but the carbocationic species unfortunately finds other exits. Any future development of this strategy for synthesis of the trichothecene nucleus must reckon with the intransigence of this rearrangement.

III. EXPERIMENTAL

General

Starting materials and reagents purchased from commercial suppliers were generally used without further purification. When necessary, liquids were distilled under argon and solids were recrystallized from the appropriate solvent. Solvents were dried by distillation from the appropriate drying agent immediately prior to use. Tetrahydrofuran (THF) and diethyl ether were distilled from potassium and benzophenone under an argon atmosphere. Diisopropylamine, triethylamine, diisopropylethylamine, dimethylsulfoxide (DMSO), hexamethylphosphoramide (HMPA), toluene, benzene and dichloromethane were distilled from calcium hydride under argon. Acetone was distilled from calcium sulfate. Methanol and ethanol were distilled from magnesium turnings. Pyridine was distilled from barium oxide under argon. All solvents used for routine isolation of products and chromatography were reagent grade and glass distilled. Moisture and air sensitive reactions were carried out under an atmosphere of argon.

Concentration under reduced pressure refers to the use of a rotary evaporator at water aspirator pressure. Residual solvent was removed by vacuum pump at pressures less than 2 torr. Reaction flasks were flame dried under a stream of argon. Syringes were oven dried at 160°C and cooled to room temperature in a dessicator over anhydrous calcium sulfate.

Analytical thin layer chromatography (TLC) was conducted using 1.5 x 5.0 cm precoated aluminum E. Merck TLC plates (0.2 mm layer thickness of silica gel 60 F-254). Spots were visualized by ultraviolet light, exposure to iodine vapor, or by heating the plate after dipping in a 3-5% solution of

phosphomolybdic acid in ethanol, or a 1% solution of vanillin in 0.1M H₂SO₄ in methanol. Flash chromatography was carried out using E. Merck silica gel 60 (230-400 mesh ASTM).

Melting points were measured using a Buchi melting point apparatus and are uncorrected. Infrared (IR) spectra were recorded with a Nicolet 5DXB FT-IR spectrometer. All chemical shifts are reported in parts per million (ppm) downfield from tetramethylsilane using the δ scale. ¹H NMR spectral data are reported in the order of: chemical shift, number of protons, multiplicity, (s = singlet, d = doublet, t = triplet, q = quartet, m = multiplet, and br = broad), and coupling constant (J) in Hertz. Mass spectra (MS) were obtained using either a Varian MAT CH-7 or a Finnigan 4500 spectrometer at an ionization potential of 70 eV. High resolution mass spectra were recorded using a Kratos MS-50 TC spectrometer. Elemental analyses were performed by Desert Analytics, Tucson, Arizona.

6-Carbomethoxy-9-ethoxy-3-oxo-2-oxabicyclo[4.4.0]deca-4,8-diene (105). Methyl coumalate (212 mg, 1.38 mmol) and 2-ethoxy-1,3-butadiene (269.6 mg, 2.75 mmol) was heated in 5 mL of benzene in a pressure-tube at 100°C. After 20 h, the solvent was evaporated under reduced pressure to leave 410 mg of crude product. This was chromatographed on silica-gel with hexane/ethyl acetate (3:1) as eluent to give 230.7 mg (66%) of **105**: mp 106°C; IR (KBr) 2980, 1731, 1664, 1438, 1248, 1223, 1195, 1038 cm⁻¹; ¹H NMR (400MHz, CDCl₃) δ 6.91 (1H, d, J=10Hz), 6.05 (1H, d, J=10Hz), 5.03 (1H, dd, J=6, 2Hz), 4.61 (1H, m), 3.78 (3H, s), 3.69 (2H, q, J=7Hz), 2.80 (2H, m), 2.42 (1H, m), 2.27 (1H, m), 1.27 (3H, t, J=7Hz); ¹³C NMR (75MHz, CDCl₃) δ 171.6, 163.1, 151.5, 149.3, 120.9,

90.3, 76.2, 62.3, 53.0, 46.3, 31.6, 29.7, 14.4; MS m/z 252 (M^+), 221, 193, 175, 155, 123, 98 (100%), 83, 70; HRMS 252.0998 (calcd for $C_{13}H_{16}O_5$ 252.0998); Anal. calcd for $C_{13}H_{16}O_5$; C, 61.9; H, 6.19. Found: C, 62.02; H, 6.29

6-Carbomethoxy-9,9-ethylenedioxy-2-oxabicyclo[4.4.0]deca-4-ene-3-one(106). Diels-Alder adduct **105** (50 mg, 0.19 mmol) was refluxed in 6 mL of benzene containing 1.3 mL of ethylene glycol and 10 mg of *p*-toluenesulfonic acid for 24 h with removal of water with a Dean-Stark trap. The product mixture was washed with saturated sodium bicarbonate solution (x3) and brine. The organic layer was dried over magnesium sulfate and solvent was removed under reduced pressure to leave 49 mg of crude product. This was chromatographed on silica-gel with hexane/ethyl acetate (1:1) as eluent to give 47.7 mg (90%) of **106**: IR (neat) 2980, 1731, 1728, 1246, 1226, 1047 cm^{-1} ; 1H NMR (400 MHz, $CDCl_3$) δ 6.70 (1H, d, $J=10Hz$), 6.11 (1H, d, $J=10Hz$), 3.97 (4H, m), 3.75 (3H, s), 2.16 (2H, m), 2.03 (2H, m), 1.62 (2H, m)

6-Carbomethoxy-9,9-diethoxy-8-hydroxy-3-oxo-2-oxabicyclo[4.4.0]deca-4-ene (108). To a solution of **105** (299 mg, 1.19 mmol) in dry ethanol (5.3 mL) was added *m*-chloroperbenzoic acid (307 mg, 1.78 mmol) and the resulting solution was stirred for 3.5 h at room temperature. After the solvent was evaporated under reduced pressure, the remaining material was dissolved in ethyl acetate (20 mL). The solution was washed with saturated sodium bicarbonate solution and the aqueous phase was extracted with ethyl acetate (x2). The combined ethyl acetate extract was dried over sodium sulfate, filtered, and the solvent was evaporated to leave

529 mg of crude product. This was chromatographed on silica-gel with hexane/ethyl acetate (1:1) as eluent to give 253 mg (68%) of **108**: IR (neat) 3478, 2877, 1731, 1729, 1252, 1072 cm^{-1} ; ^1H NMR (300MHz, CDCl_3) δ 6.81 (1H, d, $J=9\text{Hz}$), 6.02 (1H, d, $J=9\text{Hz}$), 5.02 (1H, m), 3.85 (1H, br s), 3.78 (3H, s), 3.4-3.57 (4H, m), 2.0-2.6 (4H, m), 1.17 (6H, m); ^{13}C NMR (75MHz, CDCl_3) δ 172.0, 162.6, 148.6, 120.9, 98.9, 75.9, 67.6, 57.1, 55.0, 52.7, 44.0, 33.8, 29.6, 15.3, 15.0; Anal. calcd for $\text{C}_{15}\text{H}_{20}\text{O}_7$; C, 57.32; H, 7.05. Found: C, 57.12; H, 6.78

6-Carbomethoxy-9,9-diethoxy-3-oxo-8-(2'-trimethylsilyl)ethoxymethoxy-2-oxabicyclo[4.4.0]deca-4-ene (109).

To **108** (932 mg, 2.97 mmol) in dry dichloromethane (11 mL) was added diisopropylethylamine (1.6 mL) and 2-(trimethylsilyl)ethoxymethyl chloride (1.04 mL). The solution was refluxed overnight and then washed with saturated sodium bicarbonate solution. The dichloromethane layer was dried over magnesium sulfate, filtered, and the solvent was evaporated to leave 1.1 g of crude product. This was chromatographed on silica-gel with hexane/ethyl acetate (3:1-2:1) as eluent to give 792 mg (61%) of **109**: IR (neat) 2957, 1736, 1436, 1370, 1251 cm^{-1} ; ^1H NMR (300 MHz, CDCl_3) δ 6.73 (1H, d, $J=10\text{Hz}$), 6.02 (1H, d, $J=10\text{Hz}$), 5.06 (1H, m), 4.65 (1H, d, $J=7\text{Hz}$), 4.55 (1H, d, $J=7\text{Hz}$), 3.9 (1H, m), 3.74 (3H, s), 3.71 (2H, m), 3.35-3.58 (4H, m), 2.53 (1H, m), 2.33 (2H, br s), 2.02 (1H, dd, $J=2, 4\text{Hz}$), 1.17 (3H, t, $J=7\text{Hz}$), 1.15 (3H, t, $J=7\text{Hz}$), 0.91 (2H, m), 0.02 (9H, s); ^{13}C NMR (75 MHz, CDCl_3) δ 171.9, 162.6, 148.4, 129.0, 98.2, 92.9, 76.0, 70.8, 66.3, 56.2, 54.8, 52.9, 44.6, 32.4, 30.4, 18.1, 15.1, 15.0, -1.4 (x3); MS m/z 444 (M^+), 386, 371, 297, 270, 252, 207, 155, 139, 129, 116 (100%), 98, 89, 73; HRMS 444.2180 (calcd for $\text{C}_{21}\text{H}_{36}\text{O}_8\text{Si}$

444.2180); Anal. calcd for $C_{21}H_{36}O_8Si$: C, 56.73; H, 8.16. Found: C, 56.81; H, 8.25

6-Carbomethoxy-9,9-diethoxy-3-hydroxy-8-(2'-trimethylsilyl)ethoxymethoxy-2-oxabicyclo[4.4.0]deca-4-ene (110).

To a solution of **109** (18.9 mg, 0.043 mmol) in 2 mL of dry THF was added diisobutylaluminum hydride (1M solution in hexane; 0.1 mL) slowly at $-78^{\circ}C$. The reaction mixture was stirred at this temperature for 1 h and quenched with 0.5 mL of methanol. The product mixture was poured into 10 mL of water, and the aqueous phase was extracted with ether (x3). The combined ether extract was dried over anhydrous magnesium sulfate and filtered, and the solvent was evaporated to give 17.9 mg (94%) of **110** as a mixture of diastereomers: IR (neat) 3500, 2952, 1735, 1437, 1249, 1132, 1113 cm^{-1} ; 1H NMR (300 MHz, $CDCl_3$) δ 5.85 (2H, m), 5.82 (1H, m), 4.68 (1H, m), 4.65 (1H, ds, $J=7Hz$), 3.88 (1H, m), 3.77-3.69 (2H, m), 3.67 (3H, s), 3.47 (4H, m), 2.93 (1H, d, $J=4Hz$), 2.45-1.92 (4H, m), 1.15 (3H, t, $J=7Hz$), 1.12 (3H, t, $J=7Hz$), 0.97-0.86 (2H, m), 0.01 (9H, s); ^{13}C NMR (75MHz, $CDCl_3$) δ 174.1, 133.0, 126.6, 98.9, 92.5, 88.0, 70.5, 65.9, 64.8, 55.9, 54.3, 52.1, 44.0, 31.1, 30.8, 18.1, 15.2, -1.4; Anal. calcd for $C_{21}H_{34}O_7$: C, 56.48; H, 8.58. Found: C, 56.79; H, 8.31

3-Acetoxy-6-carbomethoxy-9,9-diethoxy-8-(2'-trimethylsilyl)ethoxymethoxy-2-oxabicyclo[4.4.0]deca-4-ene (114).

To a solution of lactol **110** (107.4 mg, 0.24 mmol) in 6 mL of dry ether was added triethylamine (0.67 mL), acetic anhydride (0.23 mL) and a catalytic amount of 4-dimethylaminopyridine. The reaction mixture was stirred at room temperature overnight. The mixture was washed with 5% sodium bicarbonate

solution and the aqueous phase was extracted with ether (x2). The combined ether extract was dried over anhydrous sodium sulfate and filtered, and the solvent was evaporated to leave 110.7 mg of crude product. This was chromatographed on silica-gel with hexane/ethyl acetate (2:1) as eluent to give 104.4 mg (89%) of **114**: mp 83°C; IR (neat) 2953, 1738, 1245, 1129, 1056 cm^{-1} ; ^1H NMR (400 MHz, CDCl_3) δ 6.22 (1H, d, $J=3\text{Hz}$), 5.98 (1H, d, $J=10\text{Hz}$), 5.80 (1H, dd, $J=10, 3\text{Hz}$), 4.66 (1H, d, $J=7\text{Hz}$), 4.59 (1H, s), 4.48 (1H, d, $J=7\text{Hz}$), 3.88 (1H, m), 3.52-3.78 (2H, m), 3.68 (3H, s), 3.33-3.52 (4H, m), 2.44 (1H, m), 2.26 (1H, dd, $J=6, 4\text{Hz}$), 2.14 (1H, m), 2.08 (3H, s), 1.98 (1H, m), 1.17 (3H, t, $J=3\text{Hz}$), 1.12 (3H, t, $J=3\text{Hz}$), 0.92 (2H, m), 0.01 (3H, s); ^{13}C NMR (75MHz, CDCl_3) δ 173.7, 170.0, 134.2, 123.9, 98.6, 92.5, 88.4, 70.5, 67.5, 66.1, 56.0, 54.1, 52.2, 43.7, 31.1, 30.2, 21.3, 18.1, 15.1, -1.4 (x3); MS m/z 488 (M^+), 443, 415, 387, 355, 325, 314, 253, 177, 155, 139, 129, 116 (100%), 89; HRMS 488.2498 (calcd for $\text{C}_{23}\text{H}_{40}\text{O}_9\text{Si}$ 488.2498); Anal. calcd for $\text{C}_{23}\text{H}_{40}\text{O}_9\text{Si}$: C, 56.53; H, 8.25. found: C, 56.85; H, 8.48

Methyl Diformylacetate (118). To 5.25 g of sodium sand in 120 mL of dry ether was transferred a solution of methyl 3,3-dimethoxypropionate (16.7 g, 0.11 mol) and 57 mL of methyl formate in dry ether (60 mL) via cannula under an argon gas stream. The resulting mixture was stirred at room temperature for 24 h. Additional methyl formate (57 mL) in 60 mL of dry ether was added to the solution, and the resulting mixture was stirred for 24 h under an argon atmosphere. The reaction mixture was diluted with water and the aqueous phase was made basic with 10% NaOH solution. After washing with ether, the aqueous phase was acidified with aq. HCl and extracted with ether. The ether was washed with brine (x3), dried over sodium sulfate and filtered. Removal of

solvent under reduced pressure yielded 12.5 g (85%) of crude **118**, that was used without further purification : ^1H NMR (300 MHz, CDCl_3) δ 9.14 (2H, s), 3.82 (3H, s)

5-Carbomethoxy-3,4-dihydro-2-ethoxy-4-hydroxy-2H-pyran (120).

A solution of crude **118** (2 g) in 100 mL of ethyl vinyl ether was stirred at room temperature for 5 days. After the excess ethyl vinyl ether was evaporated under reduced pressure, the residual material was chromatographed on silica-gel with hexane/ethyl acetate (4/1 then 2/1) as eluents to give 11.8 g of **120** (mixture of isomers) in 60% yield. Spectroscopic data were obtained for one of four isomers: IR (neat) 3500, 2980, 1708, 1625, 1440, 1171, 1093 cm^{-1} ; ^1H NMR (300 MHz, CDCl_3) δ 7.49 (1H, s), 5.13 (1H, dd, $J=8$, 2Hz), 4.64 (1H, m), 3.96 (1H, dq, $J=9$, 7Hz), 3.75 (3H, s), 3.66 (1H, dq, $J=9$, 7Hz), 3.01 (1H, s), 2.1 (1H, ddd, $J=14$, 4, 2Hz), 1.93 (1H, m), 1.25 (3H, t, $J=7\text{Hz}$); ^{13}C NMR (75 MHz, CDCl_3) δ 167.8, 154.6, 109.3, 99.0, 65.5, 59.9, 51.4, 34.5, 15.0; MS m/z 202(M^+), 185, 171, 156, 139, 125, 99, 85, 72 (100%); HRMS 202.0844 (calcd for $\text{C}_9\text{H}_{14}\text{O}_5$ 202.0841).

5-Carbomethoxy-3,4-dihydro-2-ethoxy-2H-pyran-4-one (121). To a solution of **120** (6.3 g, 0.03 mol) in 150 mL of dry dichloromethane was added pyridinium dichromate (17.9 g, 0.045 mol), activated 4A molecular sieves powder (18 g), followed by 2.8 mL of glacial acetic acid. The resulting suspension was stirred at room temperature for 1 h. The product mixture was diluted with dry ether and stirred with Celite for 10 min. The ethereal solution was filtered through anhydrous magnesium sulfate and Celite. The filtrate was diluted with ether and stirred with Celite again. This was filtered once more

through magnesium sulfate and Celite. Removal of the solvent under reduced pressure left 5.74 g of **121**, which was used without further purification: ^1H NMR (300 MHz, CDCl_3) δ 8.23 (1H, s), 5.54 (1H, dd, $J=5, 10\text{Hz}$), 3.92 (1H, m), 3.81 (3H, s), 3.68 (1H, m), 2.78 (2H, m), 1.23 (3H, t, $J=6\text{Hz}$)

3-Carbomethoxypyran-4-one (116). To a solution of **121** (720 mg, 3.6 mmol) in 11 mL of dry dichloromethane was added 0.5 mL of trifluoroacetic acid and the resulting solution was stirred for 1h at room temperature. After removal of solvent, the crude product was passed through a short column of silica-gel column with ethyl acetate as eluent. The product mixture was re-chromatographed on short silica-gel with hexane/ethyl acetate(1:3) as eluent to give 448 mg of **116** (81%) as a solid: mp 84°C ; IR (KBr) 1739, 1661, 1440, 1323, 1292, 1202, 1090 cm^{-1} ; ^1H NMR (300 MHz, CDCl_3) δ 8.50 (1H, d, $J=1\text{Hz}$), 7.73 (1H, dd, $J=6, 1\text{ Hz}$), 6.48 (1H, d, $J=6\text{Hz}$), 3.90 (3H, s); ^{13}C NMR (75 MHz, CDCl_3) δ 173.7, 163.4, 161.4, 154.3, 121.1, 119.9, 52.5; MS m/z 154(M^+), 136, 123, 112, 96 (100%), 79, 69; HRMS 154.0266 (calcd for $\text{C}_7\text{H}_6\text{O}_4$ 154.0266); Anal. calcd for $\text{C}_7\text{H}_6\text{O}_4$; C, 54.55; H, 3.92. Found: C, 54.80; H, 4.04

6-Carbomethoxy-9-ethoxy-5-oxo-2-oxabicyclo[4.4.0]-3,8-decadiene (122). A solution of 4-pyranone **116** (640 mg, 4.15 mmol) and 2-ethoxy-1,3-butadiene (4.3 g, 43.9 mmol) in 5 mL of toluene was sealed under vacuum after degassing. The sealed tube was heated to 200°C for 20 h. The solvent and excess diene was evaporated under reduced pressure to leave 1.02 g of a viscous product. This was chromatographed on silica-gel with hexane/ethyl acetate (6:1) as eluent to give 890 mg (85%) of **122**: mp 99-

101°C; IR (KBr) 2980, 1754, 1731, 1677, 1598, 1216 cm^{-1} ; ^1H NMR (300 MHz, CDCl_3) δ 7.33 (1H, d, $J=6\text{Hz}$) 5.42 (1H, d, $J=6\text{Hz}$), 5.16 (1H, dd, $J=5.2, 8\text{Hz}$), 4.69 (1H, d, $J=5\text{Hz}$), 3.77 (3H, s), 3.70 (2H, dq, $J=7, 2\text{Hz}$), 2.77 (1H, dd, $J=5.2, 8\text{Hz}$), 2.52-2.40 (3H, m), 1.27 (3H, t, $J=7\text{Hz}$); ^{13}C NMR (75 MHz, CDCl_3) δ 191.1 169.2 162.2 149.8 104.8, 91.9, 78.2, 62.2, 56.3, 52.9, 30.3, 24.9, 14.5; MS m/z 252 (M^+), 220, 193 (100%), 181, 175, 147, 119, 94, 67; HRMS 252.0998 (calcd for $\text{C}_{13}\text{H}_{16}\text{O}_5$ 252.0998); Anal. calcd for $\text{C}_{13}\text{H}_{16}\text{O}_5$; C, 61.90; H, 6.39. Found: C, 61.68 ; H, 6.45.

6-Carbomethoxy-9,9-diethoxy-8-hydroxy-5-oxo-2

oxabicyclo[4.4.0]-deca-3-ene (123). To a solution of **122** (149 mg, 0.59 mmol) in 6 mL of dry ethanol was added *m*-chloroperbenzoic acid (141 mg; 1.2 equivalent). The mixture was stirred at room temperature for 3.5 h. After the solvent was evaporated under reduced pressure, the residue was taken up into ethyl acetate and organic solution was washed with saturated sodium bicarbonate solution. The aqueous layer was extracted with ethyl acetate (5 mL x 2) , and the combined ethyl acetate extract was dried over sodium sulfate. The crude product was chromatographed on silica-gel with hexane/ethyl acetate (2:1) as eluent to give 86.2 mg (46%) of **123** and 34.5 mg (19%) of **124**: IR (neat) 3500, 2995, 1737, 1681, 1678, 1601, 1266 cm^{-1} ; ^1H NMR (300MHz, CDCl_3) δ 7.20 (1H, d, $J=6\text{Hz}$), 5.39 (1H, d, $J=6\text{Hz}$), 5.16 (1H, dd, $J=5, 8\text{Hz}$), 3.8-3.75 (1H, m), 3.75 (3H, s), 3.66-3.53 (4H, m), 2.53 (1H, br s, $J=13\text{Hz}$); ^{13}C NMR (75MHz, CDCl_3) δ 187.9, 170.1, 161.2, 104.8, 98.7, 78.0, 69.7, 57.2, 56.2, 55.3, 53.0, 31.7, 30.5, 15.4, 15.3; MS m/z 314 (M^+), 244, 213, 155, 139, 116 (100%), 89; HRMS 314.1366 (calcd for $\text{C}_{15}\text{H}_{22}\text{O}_7$

314.1366); Anal. calcd for C₁₅H₂₂O₇: C, 57.31; H, 7.05. Found: C, 57.34; H, 6.84

6-Carbomethoxy-9,9-diethoxy-5-oxo-8-(2'-trimethylsilyl)ethoxymethoxy-2-oxabicyclo[2.2.0]deca-3-ene (111).

To a solution of **123** (293 mg, 0.93 mmol) in 20 mL of dry dichloromethane was added diisopropylethylamine (0.81 mL, 5.0 equiv.), followed by 3.0 equiv. of 2-(trimethylsilyl)ethoxymethyl chloride (0.49 mL) and the resulting solution was refluxed overnight. The mixture was washed with 5% sodium bicarbonate solution and the aqueous layer was extracted with dichloromethane. The dichloromethane extract was washed with brine, and dried over anhydrous magnesium sulfate. Removal of the solvent left 97 mg of crude product which was chromatographed on silica-gel with hexane/ethyl acetate (2:1) as eluent to give 76 mg (96%) of **111**: mp 63-64°C; IR (KBr) 2995, 1739, 1684, 1604, 1262, 1238, 1108 cm⁻¹; ¹H NMR (300 MHz, CDCl₃) δ 7.18 (1H, d, J=7Hz), 5.38 (1H, d, J=7Hz), 5.23 (1H, m), 4.73 (1H, d, J=7Hz), 4.68 (1H, br s), 3.72 (3H, s), 3.73-3.45 (6H, m), 2.60-2.35 (1H, br s), 2.25-1.87 (3H, br m), 1.16 (3H, t, J=7Hz), 1.13 (3H, t, J=7Hz), 0.93 (2H, m), 0.01 (9H, s); ¹³C NMR (75 MHz, CDCl₃) δ 187.4, 169.6, 161.1, 104.8, 99.0, 94.0, 78.2 (x2), 65.7, 56.1 (x2), 52.9, 29.8, 18.0 (x2), 15.5, 15.3 (x2), -1.43 (x3); MS m/z 444 (M⁺), 371, 313, 299, 281, 270, 252, 145, 129, 116 (100%), 89; HRMS 444.2180 (calcd for C₂₁H₃₆O₈Si 444.2180); Anal. calcd for C₂₁H₃₆O₈Si: C, 56.7; H, 8.16. Found: C, 56.98; H, 8.20

***cis-anti-cis*-8-Carbomethoxy-11,11-diethoxy-10-[2'-(trimethylsilyl)ethoxy]methoxy-2-oxatricyclo[6.4.0.0^{3,6}]dodec-4-**

ene-7-one (133). A solution of **111** (21 mg, 0.047 mmol) in 120 mL of dry acetone was flushed with argon for 15 min and with acetylene for 0.5 h. The solution was irradiated with a 450 watt Hanovia mercury lamp at -20°C for 0.5 h while acetylene was passed through the solution. After the solvent was obtained which was evaporated under reduced pressure, 39 mg of a pale yellow oil was chromatographed on silica-gel with hexane/ethyl acetate (6:1) as eluent to afford 10.8 mg (45%) of **133** as a colorless oil: IR (neat) 2995, 1706, 1129, 1113, 1088, 1066 cm^{-1} ; ^1H NMR (300 MHz, CDCl_3) δ 6.40 (1H, d, $J=3\text{Hz}$), 6.13 (1H, dd, $J=3, 1\text{Hz}$), 5.09 (1H, dd, $J=4, 4\text{Hz}$), 5.00 (1H, d, $J=3\text{Hz}$), 4.74 (1H, d, $J=7\text{Hz}$), 4.53 (1H, d, $J=7\text{Hz}$), 4.84 (1H, dd, $J=5, 2\text{Hz}$), 3.72 (2H, m), 3.69 (3H, s), 3.63 (1H, d, $J=3\text{Hz}$), 3.47 (4H, m), 2.46 (1H, ddd, $J=14, 5, 1\text{Hz}$), 2.19 (1H, dd, $J=14, 2\text{Hz}$), 2.08 (2H, d, $J=4\text{Hz}$), 1.15 (3H, t, $J=7\text{Hz}$), 1.13 (3H, t, $J=7\text{Hz}$), 0.99 (2H, m), -0.00 (9H, s); ^{13}C NMR (75 MHz, CDCl_3) δ 204.0, 169.0, 143.0, 136.2, 98.3, 92.8, 74.0, 71.7, 67.9, 66.0, 58.6, 56.3, 54.7, 54.6, 5.6, 31.2, 29.7, 19.5, 15.9 (x2), -1.4 (x3); MS m/z 471(M+1), 426, 425 (100%), 398, 397, 367, 353, 277, 117; HRMS 471.2413 (calcd for $\text{C}_{23}\text{H}_{39}\text{O}_8\text{Si}$ 471.2414); Anal. calcd for $\text{C}_{23}\text{H}_{38}\text{O}_8\text{Si}$: C, 58.7; H, 8.14. Found: C, 58.77; H, 8.23

cis-anti-cis-8-Carbomethoxy-11,11-diethoxy-7b-hydroxy-7a-methyl-10-[2'-(trimethylsilyl)ethoxy]methoxy-2-oxatricyclo-[6.4.0.0^{3,6}]dodec-4-ene (137) To a solution of 46 mg of **133** in 1.5 mL of dry tetrahydrofuran was added methylmagnesium bromide (3.0 M solution in ether: 1.5 equivalent) at 0°C. The reaction mixture was stirred at this temperature for 2.5 h. The mixture was quenched with saturated ammonium chloride solution, diluted with ether, and washed with saturated ammonium

chloride solution. The organic layer was dried over anhydrous magnesium sulfate and the solvent was evaporated. The crude product was chromatographed on silica-gel with hexane/ethyl acetate (4:1) as eluent to give 32.2 mg (68%) of **137**: IR (neat) 3500, 1701, 1262, 1063, 1038, 979, 836 cm^{-1} ; ^1H NMR (300 MHz, CDCl_3) δ 6.36 (1H, dd, $J=3$, 3Hz), 6.19 (1H, d, $J=3\text{Hz}$), 4.86 (1H, dd, $J=3$, 3Hz), 4.71 (1H, br s), 4.58 (1H, d, $J=7\text{Hz}$), 4.49 (1H, d, $J=7\text{Hz}$), 3.95 (1H, br s), 3.81 (1H, br s, D_2O exchanged), 3.71 (3H, s), 3.65 (2H, m), 3.48 (4H, m), 3.16 (1H, d, $J=4\text{Hz}$), 2.62 (1H, m), 2.15 (3H, m), 1.19 (6H, m), 1.14 (3H, s), 0.91 (2H, m), 0.01 (9H, s); ^{13}C NMR (75 MHz, CDCl_3) δ 175.9, 139.9, 139.8, 98.7, 92.7, 73.5, 72.6 (x2), 70.4, 65.9, 55.6, 54.4, 52.5, 51.4, 49.3, 33.6, 27.7, 23.8, 18.1, 15.6, 15.2, -1.4 (x3); Anal. calcd for $\text{C}_{24}\text{H}_{42}\text{O}_8\text{Si}$: C, 58.23; H, 8.7. Found: C, 58.29; H, 8.36

cis-anti-cis-8-Carbomethoxy-11,11-diethoxy-7b-trifluoroacetoxy-7a-methyl-10-[2'-(trimethylsilyl)ethoxy]methoxy-2-oxatricyclo

[6.4.0.0^{3,6}]dodec-4-ene (149). To a solution of **137** (4.6 mg, 0.01 mmol) in 0.5 mL of pyridine was added trifluoroacetic anhydride (20 equivalents: 29 mL) at 0°C , followed by a catalytic amount of 4-dimethylaminopyridine. After 10 min, the mixture was diluted with ether and washed with saturated cupric sulfate solution and saturated sodium bicarbonate solution. The organic layer was dried over anhydrous magnesium sulfate. Removal of the solvent under reduced pressure left 5.8 mg (98%) of **149**: IR (neat) 2995, 1781, 1728, 1218, 1168, 1155, 1126, 1063 cm^{-1} ; ^1H NMR (300 MHz, CDCl_3) δ 6.48 (1H, dd, $J=3$, 3Hz), 6.24 (1H, d, $J=3\text{Hz}$), 4.98 (1H, dd, $J=3$, 3Hz), 4.90 (1H, br s), 4.69 (1H, d, $J=7\text{Hz}$), 4.55 (1H, d, $J=7\text{Hz}$), 4.00 (1H, br s), 3.74-3.59 (2H, m) 3.69 (3H, s), 3.56-3.42 (4H, m), 3.27 (1H, d, $J=4\text{Hz}$), 2.78 (1H, dd, $J=15$, 2Hz), 2.22~2.03

(3H, m), 1.52 (3H, s), 1.19 (3H, t, J=7Hz), 2.22-2.03 (3H, m), 1.52 (3H, s), 1.19 (3H, t, J=7Hz), 1.16 (3H, t, J=7Hz), 0.92 (2H, m), 0.02 (9H, s)

6-Carbomethoxy-9,9-ethylenedioxy-5-oxo-2-oxabicyclo[4.4.0]

deca-3-ene (153). To a solution of **122** (0.53 g, 2.1 mmol) in 35 mL of ethylene glycol was added 10 mg of camphorsulfonic acid. The resulting solution was stirred at room temperature for 24 h. The mixture was diluted with water and extracted with dichloromethane (x2). The combined dichloromethane extract was washed with water and dried over anhydrous magnesium sulfate. Removal of the solvent under reduced pressure yielded 0.53 g (94%) of **153**: IR (neat) 2959, 1734, 1680, 1601, 1254, 1240, 1096, 1034 cm^{-1} ; ^1H NMR (300 MHz, CDCl_3) δ 7.23 (1H, d, J=6Hz), 5.43 (1H, d, J=6Hz), 5.24 (1H, dd, J=10Hz), 4.01-3.95 (4H, m), 3.75 (3H, s), 2.49-2.41 (1H, m), 2.17 (1H, dd, J=13, 10Hz), 2.04-1.82 (2H, m), 1.66-1.61 (2H, m); ^{13}C NMR (75 MHz, CDCl_3) δ 188.4, 170.4, 161.0, 107.7, 105.3, 79.2, 64.6, 64.4, 56.4, 53.0, 34.6, 31.1, 25.0; MS m/z 268 (M+1), 198, 183, 167, 155, 99, 86 (100%); HRMS 268.0947 (calcd for $\text{C}_{13}\text{H}_{16}\text{O}_6$ 268.0947); Anal. calcd for $\text{C}_{13}\text{H}_{16}\text{O}_6$: C, 58.20; H, 6.01. Found ; C, 58.00; H, 6.06

***cis-anti-cis*-8-Carbomethoxy-11,11-ethylenedioxy-7-oxo-2-**

oxatricyclo[6.4.0.0^{3,6}]dodec-4-ene (154). A solution of **153** (40 mg, 0.15 mmol) in 110 mL of acetone was flushed with argon for 0.5 h, and was then acetylene for 0.5 h. The solution was irradiated with a 450 Watt Hanovia mercury lamp in a stream of acetylene at -20°C for 40 min. The solvent was evaporated under reduced pressure to leave a pale yellow residue. This residue was chromatographed on silica-gel with hexane/ethyl acetate (2:1) as

eluent to afford 23.5 mg (51%) of **154**: IR (neat) 2957, 1745, 1704, 1437, 1272, 1245, 1163, 1133, 1094, 1020, 731 cm^{-1} ; ^1H NMR (300 MHz, CDCl_3) δ 6.35 (1H, d, $J=2.7\text{Hz}$), 6.18 (1H, d, $J=2.7\text{Hz}$), 5.16 (1H, d, $J=3.4\text{ Hz}$), 4.92 (1H, dd, $J=8, 4\text{Hz}$), 4.09-4.86 (4H, m), 3.73 (3H, s), 3.60 (1H, dd, $J=3, 1\text{Hz}$), 2.14-1.97 (3H, m), 1.92-1.73 (3H, m); ^{13}C NMR (75 MHz, CDCl_3) δ 204.2, 269.8, 142.1, 136.6, 107.0, 73.8, 69.2, 65.0, 63.9, 61.0, 52.8, 52.7, 37.0, 31.5, 24.8; MS m/z 295 (M^+ , 100%), 251, 199, 167, 99; HRMS 295.1182 (calcd for $\text{C}_{15}\text{H}_{19}\text{O}_6$ 295.1182); Anal. calcd for $\text{C}_{15}\text{H}_{19}\text{O}_6$: C, 61.61; H, 6.40. Found: C, 61.97; H, 6.05

cis-anti-cis-8-Carbomethoxy-11,11-diethoxy-7b-hydroxy-7a-

methyl-2-oxatricyclo[6.4.0.0^{3,6}]dodec-4-ene (155). To a solution of **154** (22.1 mg, 0.075 mmol) in 1 mL of dry ether was added methyllithium (80 mL ; 1.4 M solution in ether) at -78°C . The reaction mixture was stirred at this temperature for 1 h, and quenched with saturated ammonium chloride solution. The mixture was diluted with ether and was washed with saturated ammonium chloride solution and brine. The organic layer was dried over anhydrous magnesium sulfate. After the solvent was evaporated under reduced pressure, the crude product was chromatographed on silica-gel with hexane/ethyl acetate (1:2-2:3) as eluent to give 8 mg of **155**: IR (neat) 3502, 2951, 1722, 1290, 1256, 1224, 1207, 1176, 1115, 1091, 1041 cm^{-1} ; ^1H NMR (300 MHz, CDCl_3) δ 6.29 (1H, d, $J=3\text{Hz}$), 6.14 (1H, d, $J=3\text{Hz}$), 5.00 (1H, d, $J=4\text{Hz}$), 4.51 (1H, dd, $J=2, 2\text{Hz}$), 4.10-3.83 (4H, m), 3.76 (3H, s), 3.12 (1H, d, $J=4\text{Hz}$), 2.83 (1H, br s; D_2O exchange), 2.25-1.82 (6H, m), 1.21 (3H, s); MS m/z 311($\text{M}+1$), 309, 293(100%), 279, 249, 227, 199, 99; HRMS 311.1495

(calcd for C₁₆H₂₃O₆ 311.1495). In addition, 10 mg of recovered **154** was also isolated.

cis-anti-cis-8-Carbomethoxy-7b-hydroxy-7a-methyl-11-oxo-2-oxatricyclo[6.4.0.0^{3,6}]dodec-4-ene (156). A solution of **155** (7.1 mg, 0.023 mmol) in 0.5 mL of 98 % formic acid was stirred overnight at room temperature. The solvent was evaporated under reduced pressure to leave a yellow residue. This residue was chromatographed on silica-gel using hexane/ethyl acetate (1:1) as eluent to give 5.8 mg (95%) of **156**: IR (neat) 3450, 2995, 1719, 1289, 1252, 1150, 1117 cm⁻¹; ¹H NMR (300 MHz, CDCl₃) for the major isomer δ 6.29 (1H, d, J=3Hz), 6.09 (1H, d, J=3Hz), 4.88 (1H, d, J=4Hz), 4.49 (1H, m), 3.82 (3H, s), 3.13 (1H, d, J=4Hz), 2.89 (1H, dd, J=12, 3Hz), 2.60-2.06 (5H, m), 1.30 (3H, s); ¹³C NMR (75 MHz, CDCl₃) δ 209.1, 174.3, 140.3, 139.3, 73.2, 69.8, 54.6, 52.2, 51.9, 51.0, 45.1, 38.2, 26.7, 24.9

cis-anti-cis-8-Carbomethoxy-11,11-diethoxy-10-[2'-(trimethylsilyl)ethoxy]methoxy-2-oxatricyclo[6.4.0.0^{3,6}]dodec-7-one (157). To a solution of **133** (11mg, 0.023 mmol) in 0.4 mL of ethanol was added 2 mg of 10% palladium-on-carbon at 0°C. The resulting suspension was stirred under a hydrogen atmosphere at room temperature for 0.5 h. The mixture was filtered through anhydrous magnesium sulfate. Removal of the solvent under reduced pressure yielded 11.2 mg (100%) of **157**: IR (neat) 2952, 1739, 1708, 1122 cm⁻¹; ¹H NMR (300 MHz, CDCl₃) δ 4.83 (1H, dd, J=10, 4Hz), 4.72 (1H, d, J=7Hz), 4.68 (1H, d, J=7Hz), 4.58 (1H, m), 3.77 (3H, s), 3.74-3.46 (7H, m), 3.52 (1H, m), 2.52 (1H, dd, J=13, 4Hz), 2.38-2.12 (3H, m), 2.09-1.59 (2H, m), 1.68-1.56 (2H, m); ¹³C NMR (75 MHz,

CDCl₃) δ 205.7, 170.8, 99.0, 73.1, 71.5, 65.7, 59.9, 56.5, 56.3, 52.6, 44.9, 33.6, 29.7, 26.4, 18.0, 15.5, 15.4, -1.4 (x3)

cis-anti-cis-8-Carbomethoxy-11,11-diethoxy-7b-hydroxy-7a-methyl-10-[2'-(trimethylsilyl)ethoxy]methoxy-2-oxatricyclo-

[6.4.0.0^{3,6}]dodecane (158). To a solution of **157** (7.7 mg, 0.016 mmol) in 0.5 mL of dry ether was added methyllithium (12mL, 0.016 mmol; 1.6 M solution in ether) at -78°C. The mixture was stirred at this temperature for 1 h and quenched with saturated ammonium chloride solution at -78°C. The mixture was diluted with ether and washed with saturated ammonium chloride solution and brine. The organic layer was dried over anhydrous magnesium sulfate and the solvent was evaporated. The crude product was chromatographed on silica-gel using hexane/ethyl acetate (4:1) as eluent to give 4.6 mg (65% based on recovered starting material) of **158**: IR (neat) 3600, 2950, 1725, 1250, 1233, 1125 cm⁻¹; ¹H NMR (300 MHz, CDCl₃) δ 4.79 (1H, m), 4.66 (1H, d, J=7Hz), 4.48 (1H, d, J=7Hz), 4.44 (1H, dd, J=14, 7Hz), 3.89 (1H, m), 3.80-3.59 (2H, m), 3.69 (3H, s), 3.55-3.35 (4H, m), 2.40-1.72 (9H, m), 1.19 (3H, s), 1.15 (3H, t, J=7Hz), 1.13 (3H, t, J=7Hz), 0.89 (2H, m), 0.00 (9H, s); ¹³C NMR (75 MHz, CDCl₃) δ 173.6, 98.8, 92.7, 72.4, 71.3, 67.6, 67.3, 66.0, 55.6, 54.3, 51.7, 49.6, 41.2, 32.6, 28.3, 26.5, 24.6, 18.2, 16.0, 15.3, 15.2, -1.4 (x3) ; MS m/z 487 (M⁺), 443, 415, 399, 385, 369, 325, 301, 295, 225, 181 (100%), 117. In addition, 0.7 mg of recovered **157** was also isolated.

Methyl 4,4-Diethoxy-5-[2'-(trimethylsilyl)ethoxy]methoxy cyclohexene carboxylate (161). A suspension of sodium hydride (5 mg, 60% dispersion in mineral oil) in 0.3 mL of dimethylsulfoxide was heated

under an argon atmosphere at 70°C for 20 min. The solution was cooled to room temperature and diluted with 0.5 mL of tetrahydrofuran. To this solution was added a solution of 25.5 mg of trimethylsulfonium iodide in 0.5 mL of dimethylsulfoxide at 0°C, and the mixture was stirred for 1 min. To the above solution was added a solution of **133** (14.7 mg, 0.03 mmol) in 0.5 mL of tetrahydrofuran. The reaction mixture was stirred for 10 min at 0°C and for 7 h at room temperature. The mixture was diluted with water and extracted with ether (x2). The combined ether extract was washed with water and brine. The organic layer was dried over potassium carbonate and the solvent was evaporated under reduced pressure. The crude product was chromatographed on silica-gel with hexane/ethyl acetate (6:1) as eluent to give 8.3 mg of **161**: IR (neat) 2970, 1722, 1150, 1129, 1040, 803 cm^{-1} ; ^1H NMR (300 MHz, CDCl_3) δ 6.85 (1H, m), 4.79 (1H, d, $J=7\text{Hz}$), 4.73 (1H, d, $J=7\text{Hz}$), 4.04 (1H, m), 3.71 (3H, s), 3.65-3.53 (4H, m), 3.47 (2H, q, $J=7\text{Hz}$), 2.71-2.62 (1H, m), 2.58-2.47 (3H, m), 1.18 (3H, t, $J=7\text{Hz}$), 1.11 (3H, t, $J=7\text{Hz}$), 1.13 (2H, t, $J=5\text{Hz}$), 0.00 (9H, s); ^{13}C NMR (75MHz, CDCl_3) δ 167.4, 136.1, 127.2, 99.5, 93.8, 70.8, 65.3, 55.7, 55.6, 51.6, 31.4, 29.7, 29.5, 18.0, 15.4, 15.3, -1.4 (x3); MS m/z 374(M^+), 301, 258, 226, 213, 199, 181, 139, 116, 101, 73 (100%); HRMS 374.2125 (calcd for $\text{C}_{18}\text{H}_{34}\text{O}_6\text{Si}$ 374.2125).

5-Carbomethoxy-3,4-dihydro-2-ethoxy-4-hydroxy-3-methyl-2H-

pyran (172). A solution of **118** (2.0 g, 0.015 mol) in 80 mL of ethyl propenyl ether (**171**) was stirred at room temperature for 5 days. After removal of excess ethyl propenyl ether, the residue was chromatographed on silica-gel using hexane/ethyl acetate (2:1) as eluent to yield 2.28 g (65%) of **172** as a mixture of four diastereomers: IR (neat) 3442, 2995, 1713, 1633, 1439, 1300, 1177,

1139, 1121, 1094, 1071, 891 cm^{-1} ; ^1H NMR (300 MHz, CDCl_3) for the major isomer δ 7.47(1H, s), 4.39 (1H, d, $J=14\text{Hz}$), 4.27 (1H, m), 3.82 (1H, m), 3.77 (3H, s), 3.55 (1H, m), 1.26 (3H, s), 2.02 (1H, m), 1.23 (3H, t, $J=7\text{Hz}$)

5-Carbomethoxy-3,4-dihydro-2-ethoxy-3-methyl-4-oxo-2H-pyran

(173). To a solution of **172** (2.28 g, 0.01 mol; a mixture of four diastereomers) in 50 mL of dry dichloromethane was added 6.08 g of pyridinium dichromate, followed by 6.2 g of 4A molecular sieves powder and 1 mL of glacial acetic acid. The resulting mixture was stirred for 1 h at room temperature. The mixture was diluted with ether and stirred with Celite for 10 min. The ethereal solution was filtered through anhydrous magnesium sulfate and Celite. The filtrate was diluted with ether, stirred with Celite again, and filtered once more through magnesium sulfate and Celite. Removal of the solvent left 1.8 g (80%) of **173** as mixture of two diastereomers: IR (neat) 2997, 1744, 1706, 1595, 1437, 1389, 1295, 1180, 1129, 1107, 1076 cm^{-1} ; ^1H NMR (300 MHz, CDCl_3) for the major isomer δ 8.16 (1H, s), 5.40 (1H, d, $J=3.4\text{Hz}$), 3.79 (3H, s), 3.73-3.60 (2H, m), 1.20 (3H, m); ^{13}C NMR (75 MHz, CDCl_3) for the major isomer δ 188.6, 167.3 (x2), 110.6, 105.8, 65.9, 51.7, 44.8, 14.6, 8.4

3-Carbomethoxy-5-methyl-4-oxo-2H-pyran (169). To a solution of **173** (1.8 g, 0.08 mol) in 80 mL of dry dichloromethane was added 3 mL of trifluoroacetic acid at room temperature. The mixture was stirred for 2.5 h and the solvent was evaporated under reduced pressure to yield a crude yellow solid. This was passed through a short silica-gel pad with ethyl acetate as eluent. The mixture was re-chromatographed on a short column of silica-gel with hexane/ethyl acetate (1:3) as eluent to afford 1.15 g (82%) of **169**: mp 100-101 $^\circ\text{C}$; IR (KBr) 1747, 1654, 1445, 1409, 1326, 1291, 1124, 1028 cm^{-1} ;

^1H NMR (300 MHz, CDCl_3) δ 8.49 (1H, s), 7.73 (1H, s), 3.91 (3H, s), 1.96 (3H, s); ^{13}C NMR (75 MHz, CDCl_3) δ 174.7, 163.9, 161.3, 150.7, 128.5, 119.3, 52.4, 30.9, 11.0; MS m/z 168 (M^+), 150, 136,(100%), 122, 110, 80; HRMS 168.0420 (calcd for $\text{C}_8\text{H}_8\text{O}_4$: 168.0423); Anal. calcd for $\text{C}_8\text{H}_8\text{O}_4$: C, 57.14; H, 4.80. Found: C, 57.11; H, 4.77

6-Carbomethoxy-9-ethoxy-4-methyl-5-oxo-2-oxabicyclo[4.4.0]

deca-3,8-diene (174). A mixture of **169** (410 mg, 2.4 mmol) and 2-ethoxy-1,3-butadiene (1.2 g, 0.012 mol) in 6 mL of toluene was heated in a pressure-tube at 200°C for 21 h. After removal of the solvent under reduced pressure, the crude product was chromatographed on silica-gel with hexane/ethyl acetate (6:1) as eluent to yield 320 mg (86%) of **174**: mp 105°C; IR (KBr) 2978, 1930, 1754, 1730, 1674, 1622, 1383, 1195 cm^{-1} ; ^1H NMR (300 MHz, CDCl_3) δ 7.21 (1H, s), 5.09 (1H, dd, $J=3$, 3Hz), 4.69 (1H, br d, $J=5$ Hz), 3.76 (3H, s), 3.69 (2H, q, $J=7$ Hz), 2.74 (1H, dd, $J=16$, 5Hz), 2.50-2.35 (3H, m), 1.67 (3H, s), 1.26 (3H, t, $J=7$ Hz); ^{13}C NMR (75 MHz, CDCl_3) δ 191.7, 169.5, 158.4, 149.9, 111.5, 92.0, 78.0, 56.0, 52.7, 30.5, 24.8, 14.4, 10.5; MS m/z 266 (M^+), 237, 207 (100%), 182, 161, 151, 121, 95, 85, 77; HRMS 266.1149 (calcd for $\text{C}_{14}\text{H}_{18}\text{O}_5$ 266.1154); Anal. calcd for $\text{C}_{14}\text{H}_{18}\text{O}_5$: C, 63.15; H, 6.81. Found: C, 63.06; H, 6.77

6-Carbomethoxy-9,9-ethylenedioxy-4-methyl-5-oxo-2-

oxabicyclo[4.4.0]deca-3-ene (175). To a solution of **174** (90 mg, 0.34 mmol) in 30 mL of ethylene glycol was added 4 mg of camphorsulfonic acid. The mixture was stirred at room temperature for 24 h, diluted with dichloromethane and washed with water (100 mL x 2) and brine. The organic

layer was dried over anhydrous magnesium sulfate and the solvent was evaporated. Removal of the solvent under reduced pressure yielded 90.1 mg (96%) of **175**: IR (neat) 2958, 1734, 1674, 1624, 1241, 1174, 1097 cm^{-1} ; ^1H NMR (300 MHz, CDCl_3) δ 7.10 (1H, d, $J=1\text{Hz}$), 5.15 (1H, dd, $J=10, 5\text{Hz}$), 3.98-3.91 (4H, m), 3.74 (3H, s), 2.45-2.35 (1H, m), 2.13 (1H, dd, $J=14, 10\text{Hz}$), 1.96-1.88 (2H, m), 1.68 (3H, d, $J=1\text{Hz}$), 1.65-1.57 (2H, m); ^{13}C NMR (75 MHz, CDCl_3) δ 189.2, 170.5, 157.2, 112.0, 107.7, 78.9, 64.5, 64.3, 56.1, 52.9, 34.8, 31.1, 24.9, 10.7; MS m/z 282 (M^+), 251, 223, 198, 183, 167, 99, 86 (100%); HRMS 282.1098 (calcd for $\text{C}_{14}\text{H}_{18}\text{O}_6\text{Si}$ 282.1103); Anal. calcd for $\text{C}_{14}\text{H}_{18}\text{O}_6\text{Si}$: C, 59.57; H, 6.43. Found: C, 59.00; H, 6.59

cis-anti-cis-8-Carbomethoxy-11,11-ethylenedioxy-6-methyl-7-oxo-2-oxatricyclo[6.4.4.0^{3,6}]dodec-4-ene (176). A solution of **175** (87 mg, 0.3 mmol) in 120 mL of acetone was flushed with argon for 0.5 h and with acetylene for 0.5 h. The solution was irradiated with a 450 Watt Hanovia mercury lamp for 1.5 h while acetylene was passed through the solution. After the solvent was evaporated under reduced pressure a yellow oil was obtained, which was chromatographed on silica-gel with hexane/ethyl acetate (6:1) as eluent to yield 20.7 mg (21%) of **176**: IR (neat) 2957, 1745, 1700, 1248, 1183, 1098, 1048, 1009 cm^{-1} ; ^1H NMR (300 MHz, CDCl_3) δ 6.28, (1H, d, $J=2.7\text{Hz}$), 6.09 (1H, d, $J=2.7\text{Hz}$), 4.90 (1H, dd, $J=3.6, 3.5\text{Hz}$), 4.76, (1H, s), 4.13-4.05 (1H, m), 4.01-3.85 (3H, m), 3.72 (3H, s), 2.11-1.74 (6H, m), 1.35 (3H, s); ^{13}C NMR (75 MHz, CDCl_3) δ 206.9, 169.8, 141.2, 139.2, 107.0, 79.8, 69.2, 65.1, 63.8, 60.8, 56.9, 52.6, 37.0, 31.6, 24.7, 19.3; MS m/z 310 (M^+ , 100%), 307, 295, 291, 277, 265, 228, 211, 200, 199, 167, 156, 140, 112, 100, 60; HRMS 309.1337 (calcd for $\text{C}_{16}\text{H}_{21}\text{O}_6$ 309.1338).

9,15-Dioxo-5-hydroxy-4-methyl-4,15-epoxyapotrichothec-2-ene

(178). A solution of **176** (12 mg, 0.039 mmol) in 2.5 mL of dry benzene was stirred with 3 mg of *p*-toluenesulfonic acid at room temperature for 48 h. The solvent was evaporated under reduced pressure to leave a crude solid residue. This was chromatographed on silica-gel with hexane/ethyl acetate (1:1) as eluent to afford 5.5 mg (57%) of **178**: mp 214-215°C; IR (KBr) 3429, 2937, 2908, 1759, 1733, 1710, 1689, 1406, 1354, 1264, 1253, 1105, 1088, 1049, 1019 cm⁻¹; ¹H NMR (300 MHz, CDCl₃) δ 6.11 (1H, d, J=6Hz), 5.82 (1H, dd, J=6, 2Hz), 4.94 (1H, d, J=2Hz), 4.37 (1H, dd, J=3, 3Hz), 2.70 (2H, d, J=3Hz), 2.53 (1H, s; D₂O exchange), 2.48-2.30 (4H, m), 1.55 (3H, s); ¹³C NMR (75 MHz, CDCl₃) δ 208.4, 176.3, 138.6, 130.8, 95.0, 93.8, 93.2, 79.1, 57.0, 40.6, 34.7, 21.3, 19.3; MS m/z 251(M+1, 100%), 233, 205, 169, 141, 111; HRMS 251.0915 (calcd for C₁₃H₁₅O₅ 251.0919).

9,9-Ethylenedioxy-6-hydroxy-4-methyl-15-oxo-4,15-

epoxyapotrichothec-3-ene (179). A solution of **176** (11 mg, 0.04 mmol) in 1 mL of dry benzene was stirred with a catalytic amount of pyridinium *p*-toluenesulfonate. The mixture was stirred at room temperature for 5 days. After removal of the solvent the crude product was chromatographed on silica-gel with hexane/ethyl acetate (1:1) as eluent to yield 1.9 mg (20%) of **179**: IR (neat) 3422, 2997, 1761, 1742, 1268, 1120, 1102, 1080, 930 cm⁻¹; ¹H NMR (300 MHz, CDCl₃) δ 6.05 (1H, d, J=6Hz), 5.84 (1H, dd, J=6, 2Hz), 4.92 (1H, d, J=2Hz), 4.34 (1H, dd, J=5, 5Hz), 4.06-3.91 (4H, m), 2.36 (1H, s; D₂O exchange), 2.14-1.82 (6H, m), 1.51 (3H, s); ¹³C NMR (75 MHz, CDCl₃) δ 176.9, 138.7, 131.4, 107.2, 94.4, 93.4, 92.8, 80.5, 64.7, 65.0, 55.1, 35.2, 29.9,

21.7, 19.5; MS m/z 294 (M^+), 183, 165, 153, 115, 99 (100%), 86; HRMS 294.1103 (calcd for $C_{15}H_{18}O_6$ 294.1103); Anal. calcd for $C_{15}H_{18}O_6$; C, 61.22; H, 6.16. Found: C, 60.99; H, 5.95. In addition, 7.5 mg of recovered **176** was also isolated.

7-Hydroxy-4-methoxy-8-(methoxycarbonyl)-6-methyl-11-oxo-2-oxatricyclo[6.4.0.0^{3,7}]docec-5-ene (183). To a solution of **176** (10 mg, 0.03 mmol) in 1.5 mL of dry methanol was added a catalytic amount of *p*-toluenesulfonic acid. The mixture was refluxed overnight and the solvent was evaporated under reduced pressure to leave a light brown residue, which was chromatographed on silica-gel with hexane/ethyl acetate (1:1-1:2) as eluent to give 3.3 mg of **183**: IR (neat) 3340, 2897, 1723, 1265, 1096, 1062, 1020 cm^{-1} ; 1H NMR (300 MHz, $CDCl_3$) δ 5.82 (1H, m), 4.45 (1H, m), 4.18 (1H, s), 3.97 (1H, t, $J=2Hz$), 3.82 (3H, s), 3.39 (3H, s), 2.68-2.12 (6H, m), 1.68 (3H, m); ^{13}C NMR (75 MHz, $CDCl_3$) δ 208.3, 172.4, 143.5, 132.5, 94.9, 90.3, 87.2, 79.6, 57.0, 54.8, 52.3, 41.4, 37.7, 27.1, 12.0; MS m/z 297 (M^+), 278, 264, 214, 205, 179, 154, 142, 125 (100%), 111, 85, 82; HRMS 297.1340 (calcd for $C_{15}H_{21}O_6$ 297.1340); Anal. calcd for $C_{15}H_{21}O_6$; C, 60.80; H, 6.80. Found: C, 60.71; H, 6.65

5-Acetoxy-9,9-ethylenedioxy-4-methyl-15-oxo-4,15-epoxyapotrichothec-2-ene (184). A solution of **176** (70.3 mg, 0.23 mmol) in 3 mL of glacial acetic acid was stirred at room temperature overnight. The solvent was evaporated under reduced pressure and the residual material was chromatographed on silica-gel with hexane/ethyl acetate (1:1) as eluent to give 19.6 mg (26%) of **184**: IR (neat) 2980, 1768, 1755, 1230, 1105,

1082, 1043 cm^{-1} ; ^1H NMR (300 MHz, CDCl_3) δ 6.09 (1H, d, $J=6\text{Hz}$), 5.87 (1H, br s), 5.63 (1H, br s), 4.20 (1H, t, $J=4\text{Hz}$), 3.47 (4H, m), 2.15 (3H, s), 2.18-2.01 (6H, m), 1.48 (3H, s); ^{13}C NMR (75 MHz, CDCl_3) δ 175.4, 169.8, 137.4, 131.1, 106.8, 99.6, 93.4, 87.7, 78.0, 64.9, 64.0, 55.9, 34.6, 55.9, 34.6, 29.7, 21.8, 21.1, 19.6; MS m/z 336 (M^+), 232, 165, 153, 115, 99 (100%), 86; HRMS 336.1209 (calcd for $\text{C}_{17}\text{H}_{20}\text{O}_7$ 336.1209); Anal. calcd for $\text{C}_{17}\text{H}_{20}\text{O}_7$: C, 60.71; H, 5.99. Found: C, 60.99; H, 5.95

Methyl 4,4-Ethylenedioxcyclohexene Carboxylate (189). To a solution of **185** (14.8 mg, 0.04 mmol) in 1.5 mL of dry tetrahydrofuran was added 1.8 mg of sodium hydride (60% in mineral oil) at room temperature. The reaction mixture was refluxed for 1 h and was washed with saturated sodium bicarbonate solution. The organic layer was dried over magnesium sulfate, and the solvent was evaporated. The crude product was chromatographed on silica-gel with hexane/ethyl acetate (2:1) as eluent to give 5.8 mg (78%) of **189**: IR (neat) 2951, 1715, 1256, 1140, 1119, 1088, 1061, 1014 cm^{-1} ; ^1H NMR (300 MHz, CDCl_3) δ 6.87 (1H, m), 4.01 (4H, s), 3.72 (3H, s), 2.58-2.49 (2H, m), 2.47-2.43 (2H, m), 1.81 (2H, t, $J=7\text{Hz}$); ^{13}C NMR (75 MHz, CDCl_3) δ 167.3, 136.5, 129.8, 107.2, 64.5, 51.6, 36.1, 30.7, 23.6, 14.1; MS m/z 198 (M^+), 183, 167, 86 (100%); HRMS 198.0891 (calcd for $\text{C}_{10}\text{H}_{14}\text{O}_4$ 198.0892).

***cis-anti-cis*-11,11-Ethylenedioxy-7-hydroxy-8-hydroxymethyl-6-methyl-2-oxatricyclo[6.4.4.0^{3,6}]dodec-4-ene (191).** To a solution of **176** (102 mg, 0.33 mmol) in 12 mL of dry ether was added lithium aluminum hydride (87 mg, 2.3 mmol). The resulting suspension was stirred at room

temperature for 3 h and then refluxed for 1 h. The mixture was quenched with saturated sodium sulfate solution cautiously, and filtered through Celite and anhydrous magnesium sulfate. Removal of the solvent under reduced pressure yielded 80 mg (85%) of **191**: IR (neat) 3439, 2961, 1152, 1133, 1096, 1066, 997, 731 cm^{-1} ; ^1H NMR (300 MHz, CDCl_3) δ 6.31 (1H, d, $J=3\text{Hz}$), 5.96 (1H, d, $J=3\text{Hz}$), 4.52 (1H, s), 4.14 (1H, s), 4.08-3.79 (4H, m), 3.67 (1H, dd, $J=3, 3\text{Hz}$), 3.52 (2H, br s), 3.48 (1H, s, D_2O exchangeable), 1.87 (2H, d, $J=3\text{Hz}$), 1.81-1.67 (4H, m), 1.18 (3H, s); ^{13}C NMR (75 MHz, CDCl_3) δ 147.0, 135.7, 108.3, 79.7, 79.5, 70.2, 66.6, 64.9, 63.5, 49.6, 41.1, 36.6, 30.4, 18.3, 17.7; MS m/z 283 (M^+ , 100%), 265, 247, 203, 175, 153, 99; HRMS 283.1543 (calcd for $\text{C}_{15}\text{O}_5\text{H}_{23}$ 283.1546); Anal. calcd for $\text{C}_{15}\text{H}_{22}\text{O}_5$; C, 63.81; H, 7.85. Found: C, 63.64; H, 7.70

cis-anti-cis-11,11-Ethylenedioxy-6-methyl-7,15-O-thionyl-2-oxatricyclo[6.4.4.0^{3,6}]dodec-4-ene (193). To a solution of **191** (24.5 mg, 0.087 mmol) in 2 mL of dry dichloromethane was added 19 mg of 1,1-thiocarbonyldiimidazole at 0°C . The mixture was stirred at this temperature under argon for 2.5 h. After removal of the solvent under reduced pressure the residual material was chromatographed on silica-gel with hexane/ethyl acetate (1:5) as eluent to give 13.8 mg (50%) of **193**: IR (neat) 2957, 1273, 1267, 1242, 1214, 1101, 1052, cm^{-1} ; ^1H NMR (300 MHz, CDCl_3) δ 6.37 (1H, d, $J=3\text{Hz}$), 6.10 (1H, d, $J=3\text{Hz}$), 4.70 (1H, s), 4.63 (1H, s), 4.58 (1H, d, $J=11\text{Hz}$), 4.12-3.80 (4H, m), 4.04 (1H, d, $J=11\text{Hz}$), 3.77 (1H, m), 2.12-1.99 (2H, m), 1.91 (1H, m), 1.71 (1H, m), 1.61 (2H, m), 1.35 (3H, s); ^{13}C NMR (75 MHz, CDCl_3) δ 189.1, 145.8, 137.1, 107.0, 86.7, 79.9, 74.3, 70.9, 65.2, 63.8, 47.7, 36.5, 34.7, 30.1, 17.9, 17.5; MS m/z 325 (M^+), 303, 293, 265, 247, 233, 203, 155, 154,

153, 111, 99, 95, 86, 69 (100%); HRMS 325.1110 (calcd for C₁₆H₂₁O₅S 325.1110); Anal. calcd for C₁₆H₂₀SO₅; C, 59.06; H, 6.50. Found: C, 59.25; H, 6.13

cis-anti-cis-8-Benzoyloxymethyl-11,11-ethylenedioxy-7-hydroxy-6-methyl-8-phenoxythiocarbonyloxymethyl-2-oxatricyclo[6.4.4.0^{3,6}]dodec-4-ene (195). To a solution of **191** (25.9 mg, 0.09 mmol) in 2 mL of dry dichloromethane was added 35 mL of diisopropylethylamine, 14 mL of phenyl chlorothionoformate and a catalytic amount of 4-dimethylaminopyridine. The mixture was stirred at 0°C for 2 h and the solvent was evaporated under reduced pressure to leave an oily residue. This was chromatographed on silica-gel with hexane/ethyl acetate (1:2) as eluent to yield 21.5 mg (59%) of **195**: IR (neat) 3482, 2964, 1292, 1216, 1203, 1155, 1096, 1043, 1019, 732 cm⁻¹; ¹H NMR (300 MHz, CDCl₃) δ 7.41 (2H, m), 7.32 (1H, m), 7.08 (2H, m), 6.35 (1H, d, J=3Hz), 6.04 (1H, d, J=3Hz), 4.81 (1H, d, J=11Hz), 4.62 (1H, d, J=11Hz), 4.56 (1H, s), 4.09 (2H, m), 4.02-3.84 (4H, m), 2.11-1.55 (6H, m), 1.25 (3H, s); ¹³C NMR (75 MHz, CDCl₃) δ 194.9, 153.2, 147.0, 135.8, 129.6, 126.6, 121.7, 108.0, 79.8, 74.3, 73.6, 69.0, 64.9, 63.7, 49.8, 41.1, 36.5, 30.7, 19.8, 19.0, 64.9, 63.7, 49.8, 41.1, 36.5, 30.7, 19.8, 19.0

cis-anti-cis-11,11-Ethylenedioxy-7,15-O-carbonyl-6-methyl-2-oxatricyclo[6.4.4.0^{3,6}]dodec-4-ene (197). To a solution of **195** (14.1 mg, 0.034 mmol) in 0.5 mL of toluene was added azo-bisisobutyronitrile (1.5 mg) with 1 mL of toluene. The mixture was flushed with an argon gas for 10 min. To the above solution was added 21 mL of tri-*n*-butylstannane. The

resulting mixture was heated to 80°C for 1 h. After the solvent was evaporated under reduced pressure the residual material was chromatographed on silica-gel with hexane/ethyl acetate (1:4) as eluent to yield 5.9 mg (57%) of **197**: IR (neat) 3040, 1758, 1212, 1139, 1114, 1098 cm⁻¹; ¹H NMR (300 MHz, CDCl₃) δ 6.36 (1H, d, J=3Hz), 6.10 (1H, d, J=3Hz), 4.70 (1H, s), 4.58 (1H, s), 4.51 (1H, d, J=11Hz), 4.12 (1H, m), 4.03-3.81 (4H, m), 3.74 (1H, br s), 2.08-1.58 (6H, m), 1.31 (3H, s); ¹³C NMR (75 MHz, CDCl₃) δ 148.1, 146.0, 136.9, 107.2, 85.4, 79.9, 72.5, 71.1, 65.2, 63.8, 48.1, 36.7, 34.6, 30.1, 17.4 (x2)

cis-anti-cis-8-Acetoxymethyl-11,11-ethylenedioxy-7-hydroxy-6-methyl-2-oxatricyclo[6.4.4.0^{3,6}]dodec-4-ene (198). To a solution of **191** (11.4 mg, 0.04 mmol) in 1 mL of dry dichloromethane was added 12 mL of triethylamine and 4 mL of acetic anhydride at 0°C. The mixture was stirred at this temperature for 2 h and washed with saturated sodium bicarbonate solution. The organic layer was dried over anhydrous magnesium sulfate and the solvent was evaporated. The crude product was chromatographed on silica-gel with hexane/ethyl acetate (1:2) as eluent to afford 6.6 mg (50%) of **198**: IR (neat) 3482, 2990, 1739, 1241, 1098, 1035 cm⁻¹; ¹H NMR (300 MHz, CDCl₃) δ 6.35 (1H, d, J=3Hz), 6.04 (1H, d, J=3Hz), 4.55 (1H, s), 4.47 (1H, d, J=12Hz), 4.13 (1H, d, J=12Hz), 4.11-4.04 (1H, m), 3.99-3.82 (5H, m), 2.21 (1H, d, J=7Hz), 2.08 (3H, s), 2.07-1.93 (3H, m), 1.81-1.79 (1H, m), 1.69 (1H, dd, J=14, 4Hz), 1.60-1.50 (1H, m), 1.24 (3H, s); ¹³C NMR (75 MHz, CDCl₃) δ 171.4, 147.2, 135.7, 108.0, 79.8, 74.1, 69.5, 64.9, 64.8, 63.7, 49.7, 40.8, 36.6, 30.6, 20.9, 19.9, 18.9; MS m/z 373 (M⁺, 100%), 371, 356, 337, 325, 311, 295, 281, 265, 263, 259, 247, 235, 221, 203, 154; HRMS 373.2014 (calcd for C₂₂H₂₉O₅ 373.2015). These was also isolated 2.1 mg of a diacetate: IR

(neat) 2992, 1742, 1371, 1242, 1102, 1053, 1029 cm^{-1} ; ^1H NMR (300 MHz, CDCl_3) δ 6.39 (1H, d, $J=3\text{Hz}$), 6.02 (1H, d, $J=3\text{Hz}$), 5.09 (1H, s), 4.06 (1H, s), 4.18 (1H, d, $J=14\text{Hz}$), 4.14 (1H, d, $J=14\text{Hz}$), 4.12-4.08 (1H, m), 4.05 (1H, m), 3.97-3.82 (3H, m), 2.09 (3H, s), 2.05 (3H, s), 2.09-1.52 (6H, m), 1.05 (3H, s); ^{13}C NMR (75 MHz, CDCl_3) δ 170.9, 170.7, 147.2, 135.5, 107.7, 79.7, 75.1, 68.8, 65.1, 63.6, 63.5, 48.5, 39.1, 36.2, 30.5, 20.8, 20.6, 19.1; MS m/z 367 (M^+), 353, 307, 265, 247, 117, 99, 87, 73, 59 (100%); HRMS 367.1757 (calcd for $\text{C}_{19}\text{H}_{26}\text{O}_7$ 367.1757).

cis-anti-cis-8-Benzoyloxymethyl-11,11-ethylenedioxy-7-hydroxy-6-methyl-2-oxatricyclo[6.4.4.0^{3,6}]dodec-4-ene (199). To a solution of **191** (35 mg, 0.12 mmol) in 4 mL of dry tetrahydrofuran was added 11 mg of sodium hydride (60% in mineral oil) at 0°C . The suspension was stirred at this temperature for 0.5 h. To this mixture was added 16 mL of benzyl bromide at 0°C . The resulting mixture was stirred at room temperature overnight. The mixture was quenched with saturated ammonium chloride solution and washed with brine. The organic layer was dried over anhydrous magnesium sulfate and the solvent was evaporated. The crude product was chromatographed on silica-gel with hexane/ethyl acetate (1:1) as eluent to give 13.6 mg (30%) of **199**: IR (neat) 3498, 2957, 2926, 1098, 1065, 1045, 1028 cm^{-1} ; ^1H NMR (300 MHz, CDCl_3) δ 7.33 (5H, m), 6.34 (1H, d, $J=3\text{Hz}$), 5.99 (1H, d, $J=3\text{Hz}$), 4.52 (2H, m), 4.14 (1H, s), 4.09 (1H, m), 3.99-3.79 (4H, m), 3.70 (1H, dd, $J=3, 3\text{Hz}$), 3.54 (1H, d, $J=2\text{Hz}$), 3.34 (1H, d, $J=9\text{Hz}$), 1.95-1.79 (4H, m), 1.67-1.56 (2H, m), 1.20 (3H, s); ^{13}C NMR (75 MHz, CDCl_3) δ 147.6, 137.2, 135.2, 128.6 (x2), 108.3, 80.8, 78.5, 74.5, 74.1, 69.8, 65.0, 63.6,

49.2, 41.3, 36.8, 30.6, 18.6, 18.3; MS m/z 325 (M^+), 307, 265, 247, 203, 118, 88, 60(100%); HRMS 325.1652 (calcd for $C_{17}H_{25}O_6$ 325.1651).

cis-anti-cis-8-Acetoxyethyl-11,11-ethylenedioxy-6-methyl-7-oxo-2-oxatricyclo[6.4.4.0^{3,6}]dodec-4-ene (200). To a solution of **198** (9.3 mg, 0.03 mmol) in 1.5 mL of dry dichloromethane was added pyridinium dichromate (16.5 mg, 0.045 mmol) and 17 mg of 4A sieves powder. The mixture was stirred at room temperature for 1h, diluted with ether and stirred with Celite to precipitate residual chromium salts. The supernatant material was filtered through magnesium sulfate and Celite. Removal of the solvent under reduced pressure left 9.5 mg of crude product. This was chromatographed on silica-gel with hexane/ethyl acetate (1:1) as eluent to give 8.7 mg (95%) of **200**: IR (neat) 2990, 1743, 1700, 1375, 1236, 1183, 1103, 1082, 1054, 1040 cm^{-1} ; 1H NMR (300 MHz, $CDCl_3$) d 6.31 (1H, d, $J=3Hz$), 6.03 (1H, d, $J=3Hz$), 4.70 (1H, s), 4.57 (1H, m), 4.45 (1H, d, $J=14Hz$), 4.39 (1H, d, $J=14Hz$), 4.11-4.06 (1H, m), 3.97-3.88 (3H, m), 2.21-2.01 (3H, m), 1.98 (3H, s), 1.72-1.58 (2H, m), 1.45-1.37 (1H, m), 1.35 (3H, s); ^{13}C NMR (75 MHz, $CDCl_3$) d 211.0, 170.5, 140.6, 139.1, 107.1, 79.8, 68.6, 65.1 (x2), 63.9, 57.8, 51.3, 36.1, 30.5, 25.6, 20.7, 19.2; Anal. calcd for $C_{17}H_{22}O_6$: C, 63.34; H, 6.88. Found: C, 63.31; H, 6.96

cis-anti-cis-8-Benzoyloxyethyl-11,11-ethylenedioxy-6-methyl-7-oxo-2-oxatricyclo[6.4.4.0^{3,6}]dodec-4-ene (201). To a solution of **199** (3.2 mg, 0.009 mmol) in 0.5 mL of dry dichloromethane was added 5.1 mg of pyridinium dichromate and 5.0 mg of 4A sieves powder. The mixture was stirred at room temperature for 1 h, diluted with ether and was further stirred

with 20 mg of Celite. The suspension was filtered through anhydrous magnesium sulfate and Celite. Removal of the solvent under the reduced pressure left 4mg of crude product. This was chromatographed on silica-gel with hexane/ethyl acetate (1:1) as eluent to give 3.1 mg (97%) of **201**: IR (neat) 2956, 2927, 1698, 1097, 1051 cm^{-1} ; ^1H NMR (300 MHz, CDCl_3) δ 7.38-7.19 (5H, m), 6.28 (1H, d, $J=3\text{Hz}$), 6.01 (1H, d, $J=12\text{Hz}$), 4.84 (1H, dd, $J=3, 3\text{Hz}$), 4.69 (1H, s), 4.48 (1H, d, $J=12\text{Hz}$), 4.37 (1H, d, $J=12\text{Hz}$), 4.09 (1H, m), 3.98-3.86 (3H, m), 3.96 (1H, d, $J=9\text{Hz}$), 3.59 (1H, d, $J=9\text{Hz}$), 2.09-1.93 (2H, m), 1.68-1.53 (2H, m), 1.42-1.31 (2H, m), 1.34 (3H, s); ^{13}C NMR (75 MHz, CDCl_3) δ 212.2, 140.9, 138.8, 138.2, 128.2 (x2), 127.5, 127.1 (x2), 107.3, 79.9, 73.4, 71.2, 68.6, 65.0, 63.8, 57.7, 52.5, 36.0, 30.8, 25.6, 19.3; Anal. calcd for $\text{C}_{22}\text{H}_{26}\text{O}_5$: C, 70.33; H, 7.07. Found: C, 70.28; H, 7.07

5-Hydroxy-4-methyl-9-oxo-4,15-epoxyapotrichothec-2-ene (204).

To a solution of **201** (7.3 mg, 0.023 mmol) in 1.2 mL of dry benzene was added a catalytic amount of *p*-toluenesulfonic acid. The resulting mixture was stirred at room temperature for 40 h. After removal of the solvent the crude product was chromatographed on silica-gel with hexane/ethyl acetate (1:1-1:2) as eluent to yield 3.5 mg (55%) of **204**: IR (neat) 3400, 1713, 1104, 1044, 991 cm^{-1} ; ^1H NMR (300 MHz, CDCl_3) δ 5.88 (1H, d, $J=6\text{Hz}$), 5.69 (1H, dd, $J=6, 2\text{Hz}$), 4.73 (1H, d, $J=2\text{Hz}$), 4.29 (1H, dd, $J=4, 3\text{Hz}$), 3.81 (1H, d, $J=9\text{Hz}$), 3.71 (1H, d, $J=9\text{Hz}$), 2.70 (1H, dd, $J=17, 4\text{Hz}$), 2.60-2.48 (2H, m), 2.33-2.22 (2H, m), 2.12-2.05 (1H, m), 1.68-1.57 (1H, m), 1.36 (3H, s); ^{13}C NMR (75 MHz, CDCl_3) δ 210.2, 139.3, 130.2, 97.8, 94.8, 91.9, 80.7, 75.6, 55.5, 41.4, 36.0, 22.4, 18.7; MS m/z 236 (M^+), 208, 191, 177, 160, 151, 145, 136, 121, 111, 103, 95, 87, 79 (100%); HRMS 236.1049 (calcd for $\text{C}_{13}\text{H}_{16}\text{O}_4$ 236.1049).

cis-anti-cis-11,11-Ethylenedioxy-6-methyl-7-hydroxy-8-p-toluenesulfonyloxymethyl-2-oxatricyclo[6.4.4.0^{3,6}]dodec-4-ene (**205**). To a solution of **191** (75 mg, 0.27 mmol) in 8 mL of dry dichloromethane was added 0.14 mL of diisopropylethylamine, 55.6 mg of *p*-toluenesulfonyl chloride and a catalytic amount of 4-dimethylaminopyridine. The mixture was stirred at 0°C for 6 h and washed with saturated sodium bicarbonate solution. The organic layer was dried over anhydrous magnesium sulfate and the solvent was evaporated. The crude product was chromatographed on silica-gel with dichloromethane/ethyl acetate (2:1) as eluent to give 58 mg (55%) of **205**: IR (neat) 3350, 3059, 1359, 1176, 1097, 953, 838 cm⁻¹; ¹H NMR (300 MHz, CDCl₃) δ 7.78 (1H, d, J=8Hz), 7.37 (1H, d, J=8Hz), 6.26 (1H, d, J=3Hz), 6.01 (1H, d, J=3Hz), 4.50 (1H, s), 4.27 (1H, d, J=10Hz), 4.09 (1H, d, J=10Hz), 4.06 (1H, s), 4.07-4.01 (1H, m), 3.89 (2H, m), 3.71 (2H, m), 2.46 (3H, s), 2.04-1.83 (2H, m), 1.81-1.62 (2H, m), 1.48-1.37 (2H, m); ¹³C NMR (75 MHz, CDCl₃) δ 147.0, 145.2, 135.8, 132.4, 130.1, 130.0, 127.9, 79.7, 72.7, 69.9, 68.8, 64.8, 63.7, 50.0, 41.1, 36.2, 30.5, 21.7, 19.8, 19.0; MS m/z 437 (M+1), 419, 391, 371, 265, 247, 217, 173 (100%), 153, 125, 113, 109; HRMS 437.1633 (calcd for C₂₂H₂₉O₇S 437.1634).

cis-anti-cis-11,11-Ethylenedioxy-6-methyl-7-oxo-8-p-toluenesulfonyloxymethyl-2-oxatricyclo[6.4.4.0^{3,6}]dodec-4-ene (**206**). To a solution of **205** (13.7 mL, 0.03 mmol) in 3 mL of dry dichloromethane was added 18 mg of pyridinium dichromate and 19 mg of 4A sieves powder. The mixture was stirred at room temperature for 1 h, diluted with 3 mL of diethyl ether and stirred with Celite. The suspension was filtered through Celite and anhydrous magnesium sulfate. Removal of the solvent

under reduced pressure left 13.4 mg (98%) of **206**: IR (neat) 3059, 1700, 1364, 1178, 1101, 1053, 953 cm^{-1} ; ^1H NMR (300 MHz, CDCl_3) δ 7.72 (1H, d, $J=8\text{Hz}$), 7.36 (1H, d, $J=8\text{Hz}$), 6.29 (1H, d, $J=3\text{Hz}$), 5.94 (1H, d, $J=3\text{Hz}$), 4.68 (2H, s), 4.41 (1H, d, $J=9\text{Hz}$), 4.19 (1H, d, $J=9\text{Hz}$), 3.98 (1H, m), 3.95-3.83 (3H, m), 2.59 (3H, s), 2.08 (1H, m), 2.00 (2H, d, $J=4\text{Hz}$), 1.58-1.28 (4H, m), 1.43 (3H, s); ^{13}C NMR (75 MHz, CDCl_3) δ 209.7, 145.0, 140.5, 139.4, 132.3, 129.9, 127.9, 106.8, 79.7, 70.2, 67.8, 65.1, 63.9, 57.7, 51.1, 35.7, 30.5, 25.3, 21.7, 19.0; MS m/z 435($M+1$), 345, 263, 173 (100%), 151, 93; HRMS 435.1478 (calcd for $\text{C}_{22}\text{H}_{27}\text{O}_7\text{S}$ 435.1478).

7-Hydroxy-6-methylene-11-oxo-8-*p*-toluenesulfonylmethyl-11-oxo-2-oxatricyclo[6.4.0.0^{3,7}]dodec-4-ene (208). To a solution of **206** (34.1 mg, 0.08 mmol) in 3.5 mL of dry benzene was added 15 mg of camphorsulfonic acid. The mixture was refluxed for 1.5 h, and the solvent was evaporated under reduced pressure. The residual material was chromatographed on silica-gel with dichloromethane/ethyl acetate (2:1-1:2) as eluent to leave 18.5 mg (60%) of **208**: IR (neat) 3470, 1717, 1361, 1176, 1099, 988, 961, 791 cm^{-1} ; ^1H NMR (300 MHz, CDCl_3) δ 7.78 (1H, d, $J=8\text{Hz}$), 7.37 (1H, d, $J=8\text{Hz}$), 6.37 (1H, d, $J=6\text{Hz}$), 5.39 (1H, m), 5.22 (1H, s), 5.16 (1H, s), 4.87 (1H, d, $J=2\text{Hz}$), 4.03 (1H, d, $J=10\text{Hz}$), 3.98 (1H, d, $J=10\text{Hz}$), 3.85 (1H, m), 2.61-2.13 (4H, m), 2.47 (3H, s), 2.01-1.93 (2H, m); ^{13}C NMR (75 MHz, CDCl_3) δ 209.3, 153.5, 145.4, 136.6, 133.8, 132.3, 130.1, 127.8, 109.5, 92.6, 78.7, 71.6, 48.1, 41.4, 36.3, 23.4, 21.7; MS m/z 390, 279, 218, 200, 155, 125, 109 (100%), 91, 81; HRMS 390.1138 (calcd for $\text{C}_{20}\text{H}_{22}\text{O}_6\text{S}$ 390.1138); Anal. calcd for $\text{C}_{20}\text{H}_{22}\text{O}_6\text{S}$: C, 61.52; H, 5.68. Found: C, 61.14; H, 5.77

IX. BIBLIOGRAPHY

1. Ueno, Y. *Adv. Nutr. Res.* **1980**, *3*, 301.
2. Bamburg, J.R. Mycotoxins and other Fungal Related Food Problems. *Adv. Chem. Ser. No. 149*, American Chemical Society; Washington, D.C., **1976**.
3. Tamm, C. *Fortschr. Chem. Org. Nat.* **1974**, *31*, 64.
4. a) Cole, R.J.; Cox, R.H. In *Handbook of Toxic Fungal Metabolites*; Academic: New York, **1981**; Chapter 5.
b) Ueno, Y. *Trichothecenes - Chemical, Biological and Toxicological Aspects*; *Developments in Food Science 4*; Elsevier: New York, **1983**; Chapters 1, 5, 6.
5. Anderson, D.W.; Black, R.M.; Lee, C.G.; Pottage, C.; Rickard, R.L.; Sanford, M.S.; Webber, T.D.; Williams, N.E. *J. Med. Chem.* **1989**, *32*, 555.
6. a) Grove, J.F.; Martumer, P.H. *Biochem. Pharmacol.* **1969**, *18*, 1473.
b) Freeman, G.G. *J. Gen. Microbiol.* **1955**, *12*, 213.
7. Doyle, T.W.; Brander, W.T. In *Anticancer Agents Based on Natural Products*; Cassady, J. M.; Douros, J.D., Eds.; Academic: New York: **1980**; Vol. 6, p 43.
8. Abrahamsson, S.; Nilsson, B. *Proc. Chem. Soc.* **1964**, 188.
9. Colvin, E.W.; Malchenco, S.; Raphael, R.A. ; Roberts. J. S. *J. Chem. Soc. Perkin Trans. I*, **1973**, 1989.
10. Schlessinger, R. H.; Nugent, R. A. *J. Am. Chem. Soc.* **1982**, *104*, 1116.
11. Kraus, G. A.; Roth, B.; Frazier, K.; Shimagaki, M. *J. Am. Chem. Soc.* **1982**, *104*, 1114.

12. a) Trost, B. M.; McDougal, P. G.; Haller, K. J. *J. Am. Chem. Soc.* **1984**, *106*, 383.
b) Trost, B. M.; McDougal, P. G. *J. Am. Chem. Soc.* **1982**, *104*, 6110.
13. a) Roush, W. R.; D'Ambra, T. E. *J. Org. Chem.* **1980**, *45*, 3927.
b) Roush, W. R.; D'Ambra, T. E. *J. Am. Chem. Soc.* **1983**, *105*, 1059.
14. Brooks, D. W.; Grothaus, P. G.; Mazdiyasn, H. *J. Am. Chem. Soc.* **1983**, *105*, 4472.
15. Ziegler, F. E.; Sobolov, S. B. *J. Am. Chem. Soc.* **1990**, *112*, 2749.
16. Colvin, E. W.; Egan, M. J.; Kerr, F. W. *J. Chem. Soc., Chem. Commun.* **1990**, 1200.
17. Fujimoto, Y.; Yokura, S.; Nakamura, T.; Morikawa, T.; Tatsuno, T. *Tetrahedron Lett.* **1974**, *15*, 2523.
18. a) Cane, D.E.; Croteau, R. In *Methods Enzymol* **1984**, *110*, 383-405.
b) Cane, D.E.; Ha, H.J. *J. Am. Chem. Soc.* **1986**, *108*, 3097.
c) Hanson, J.R.; Achilladelis, B.A.; Adams, P.M. *J. Chem. Soc. Perkin Trans. I* **1972**, 1425.
19. a) Nozoe, S.; Machida, Y. *Tetrahedron Lett.* **1970**, *11*, 1177.
b) Nozoe, S.; Machida, Y. *Tetrahedron Lett.* **1970**, *11*, 2671.
20. Jones, E.R.H.; Lowe, G. *J. Chem. Soc.* **1960**, 3959.
21. a) Masuoka, N.; Kamikawa, T. *Tetrahedron Lett.* **1976**, *17*, 1691.
b) Still, W. C.; Tsai, M. -Y. *J. Am. Chem. Soc.* **1980**, *102*, 3654.
c) Pearson, A. J.; Ong, C. W. *J. Am. Chem. Soc.* **1981**, *103*, 6686.
d) Schlessinger, R. H.; Nugent, R. A. *J. Am. Chem. Soc.* **1982**, *104*, 1116.
22. a) Wilson, C.V. *Org. React.* **1957**, *9*, 332.
b) Gunstone, F.D. *Adv. Org. Chem.* **1960**, *1*, 103.

23. Trost, B.M.; McDougal, J. *J. Am. Chem. Soc.* **1982**, *104*, 6110.
24. a) Nakahara, Y.; Tatsuno, T. *Chem. Pharm. Bull.* **1980**, 1981.
b) Matsui, T.; Inoue, J.; Nakayama, M.; White, J.D. *Bull. Chem. Soc., Japan* **1983**, *56*, 647.
25. Dewar, M.J.S.; Dougherty, R.C. *The PMO theory of Organic Chemistry*, Plenum, N.Y., **1975**, p. 339.
26. Hill, David E. *Ph.D. Dissertation*, Oregon State University, 1986.
27. Shoemaker, C.B.; Shoemaker, D.P.; Barowski, S.L.; French, R.J.; Kazerouni, M.R. *Acta Crystallogr., Sect. C.: Crys. Struct. Commun.* **1983**, *C39*, 1676.
28. Frimer, A. *Synthesis*, **1977**, 578.
29. Lipshutz, B.H.; Pegram, J.J. *Tetrahedron Lett.* **1980**, *2*, 3343.
30. a) Evans, D.A.; Andrews, G.L.; Sims C.L. *J. Am. Chem. Soc.* **1971**, *93*, 4956.
b) Dauben, W.G.; Michino, D.M. *J. Org. Chem.* **1977**, *42*, 682.
31. a) Corey, E.J.; Suggs, J.W. *Tetrahedron Lett.* **1975**, *16*, 2647.
b) Piancatelli, G.; Scettri, A.; D'Auria, M. *Synthesis* **1982**, 245.
32. Collins, J.C.; Hess, W.W.; Frank, F.J. *Tetrahedron Lett.* **1968**, *9*, 3363.
33. Reischl, W.; Okamura, W.H.; *J. Am. Chem. Soc.* **1982**, *104*, 6115.
34. a) Nakai, T. *Tetrahedron Lett.* **1977**, 2425.
b) Hacker, R.E.; Balko, T.W. *J. Org. Chem.*, **1973**, *38*, 2106.
35. a) Henry, P.M. *J. Am. Chem. Soc.* **1972**, *94*, 5200
b) Overman, L.E.; Knoll, F.M. *Tetrahedron Lett.* **1979**, 321.
36. a) Grieco, P.A.; Takigawa, T.; Bongers, S.L.; Tanaka, H. *J. Am. Chem. Soc.* **1980**, *102*, 7588.
b) Grieco, P.A.; Tuthill, P.A.; Sham, H.L. *J. Org. Chem.* **1981**, *46*, 5005.

37. a) Aziz, G. *J. Org. Chem.* **1962**, *27*, 2954.
b) Alder, K. In "*Newer Methods of Preparative Organic Chemistry*" New York, **1948**, p. 501.
38. a) Buchi, G.; Carlson, J.A.; Powell, J.E.; Tietze, L.-F. *J. Am. Chem. Soc.* **1973**, *95*, 540.
b) Panizzi, L. *Gazz. Chim. Ital.* **1946**, *76*, 56.
39. a) Fleming, I. In "*Frontier Orbitals and Organic Chemical Reactions*" Wiley, London, **1976**, p 114-127.
b) Sutstmann, R.; Tril, H. *Angew. Chem., Int. Ed. Engl.*, **1972**, *11*, 838.
40. a) Schmidt, R.R.; Maier, M. *Tetrahedron Lett.* **1985**, *26*, 2605.
b) Tietze, L.-F.; Glusenkamp, K.H. *Angew. Chem., Int. Ed. Engl.*, **1983**, *22*, 887
c) Tietze, L.-F.; Glusenkamp, K.H.; Harms, K.; Remberg, G. *Tetrahedron Lett.* **1982**, *23*, 1147.
41. Czernecki, S.; Georgoulis, C.; Stevens, C.L.; Vijayakumaran, K. *Tetrahedron Lett.* **1985**, *26*, 1699.
42. Ciamician, G.; Silber, P. *Chem. Ber.* **1908**, *41*, 1928.
43. Baldwin, S.W. In *Organic Photochemistry*, Padwa, A. Ed., Marcel Dekker, N.Y., **1981**, vol. 5, p 123.
44. Cantrell, T.S.; Haller, W.S.; Williams, J.C. *J. Org. Chem.* **1969**, *34*, 509.
45. Serebryakov, E.P. *Acad. Nauk. SSSR Div. Chem. Sci.* **1984**, *33*, 120.
46. Kagawa, S.; Matsumoto, S.; Nishida, S.; Yu, S.; Morita, J.; Ichihara, T.; Shirahama, H.; Matsumoto, T. *Tetrahedron Lett.* **1969**, *10*, 3973.
47. Ohfune, Y.; Shirahama, H.; Matsumoto, T. *Tetrahedron Lett.* **1975**, *16*, 4377.

48. Corey, E.J.; Bass, T.D.; LeMahieu, R.; Mitra, R.B. *J. Am. Chem. Soc.* **1964**, *86*, 5570.
49. Devaquiet, A. *J. Am. Chem. Soc.* **1972**, *94*, 5160.
50. Wexler, A.J.; Hyatt, J.A.; Reynolds, P.W.; Cottrell, C.; Swenton, I.S. *J. Am. Chem. Soc.* **1978**, *100*, 512.
51. White, J.D.; Matsui, T.; Thomas, J.A. *J. Org. Chem.* **1981**, *46*, 3376.
52. a) Cox, J.D. *Tetrahedron* **1963**, *19*, 1175.
b) Turner, R.B. *J. Am. Chem. Soc.* **1968**, *90*, 4315.
c) Wilberg, K. B. *J. Am. Chem. Soc.* **1968**, *90*, 3395.
53. Cieplak, A.S. *J. Am. Chem. Soc.* **1981**, *103*, 4540.
54. a) Bake, J.W. In "*Hyperconjugation*"; Oxford University Press; London, 1952.
b) Taft, R.W.; Lewis, I.C. *Tetrahedron*, **1959**, *5*, 210.
55. a) Corey, E.J.; Nozoe, S. *J. Am. Chem. Soc.* **1964**, *86*, 1652.
b) Ohfuné, Y.; Shirahama, H.; Matsumoto, T. *Tetrahedron Lett.* **1978**, *34*, 1207.
c) Duc, D.K.M.; Fetizon, M.; Lazare, S. *Tetrahedron Lett.* **1978**, *34*, 1207.
d) Pirrung, M.C. *J. Am. Chem. Soc.* **1981**, *103*, 82.
56. Fetizon, M.; Khac, D.D.; Tho, N.D. *Tetrahedron Lett.* **1986**, *27*, 1777.
57. Hess, B.A. *J. Am. Chem. Soc.* **1971**, *93*, 1000.
58. Miller, J.A.; Ullah, G.M. *J. Chem. Soc., Chem. Commun.* **1982**, 874.
59. Ikeda, M.; Kido, M. *J. Org. Chem.* **1983**, *48*, 4241.
60. Corey, E.J.; Chaykovsky, M. *J. Am. Chem. Soc.* **1965**, *87*, 1353.
61. Lombardo, L. *Tetrahedron Lett.* **1982**, *23*, 4293.
62. Corey, E.J.; Greenwald, R.; Chaykovsky, M.J. *J. Org. Chem.* **1963**, *28*, 1128.

63. Cargill, R.L.; Jackson, T.E.; Peet, N.P.; Pond, D.M. *Acc. Chem. Research* **1974**, *7*, 106.
64. a) Cargill, R.L.; Crawford, R.L. *Tetrahedron Lett.* **1967**, 169.
b) Cargill, R.L.; Crawford, R.L. *J. Org. Chem.* **1970**, *35*, 356.
65. Paquette, L.A. *J. Am. Chem. Soc.* **1990**, *112*, 239.
66. Trost, B.M.; Klum, T.P. *J. Am. Chem. Soc.* **1981**, *103*, 1864.
67. Trost, B.M.; Verhoeven, T.R. *J. Am. Chem. Soc.* **1980**, *102*, 4730.
68. Barton, D.H.R.; AcCombie, S.W. *J. Chem. Soc., Perkin Trans. I*, **1975**, 1574.
69. a) Robins, M.J.; Wilson, I.S. *J. Am. Chem. Soc.* **1981**, *103*, 932.
b) Robins, M.J.; Wilson, I.S.; Hansske, F.J. *J. Am. Chem. Soc.* **1983**, *105*, 4059.
70. Hartwig, W. *Tetrahedron*, **1983**, *39*, 2609.