

# GUIDE TO DETERMINING SLOPE OF GRAIN IN LUMBER AND VENEER

**Information Reviewed and Reaffirmed**

**May 1955**  
INFORMATION REVIEWED  
AND REAFFIRMED  
1960

**No. 1585**

LOAN COPY

Please return to:

Wood Engineering Research  
Forest Products Laboratory  
Madison, Wisconsin 53705

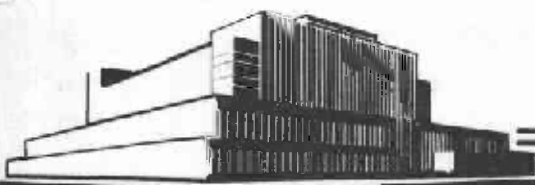

FOREST PRODUCTS LABORATORY  
MADISON 5, WISCONSIN

UNITED STATES DEPARTMENT OF AGRICULTURE  
FOREST SERVICE

In Cooperation with the University of Wisconsin

TABLE OF CONTENTS

	<u>Page</u>
<b>SUMMARY</b>	
Condensed Guide for Determining Slope of Grain in Kinds of Lumber Used in Aircraft Construction .....	1
Diagonal Grain .....	1
Spiral Grain .....	1
Condensed Guide for Determining Slope of Grain in Kinds of Veneer Used in Aircraft Construction .....	2
<b>INTRODUCTION</b>	
Meaning of Slope of Grain .....	2
Objections to Excessive Slope of Grain .....	3
<b>PART I -- LUMBER</b>	
Detecting Slope of Grain .....	3
Slope of Grain in the Radial Plane -- Diagonal Grain .....	4
Indicators of Diagonal Grain on Radial Surfaces .....	5
1. Annual growth rings .....	5
2. Pores or magnified fibers .....	5
3. Boundary between sapwood and heartwood .....	5
4. Pitch pockets .....	5
5. Longitudinal discolored streaks .....	6
6. Ink, scribe, pick, and splitting tests .....	6
Indicators of Diagonal Grain on Tangential Surfaces .....	6
7. Frequencies of intersection of annual rings with surface .....	6
8. Chipped surface .....	6
9. Length of pores or resin ducts .....	6
10. Pick test .....	7
Slope of Grain in the Tangential Plane -- Spiral Grain .....	7
Indicators of Spiral Grain on Tangential Surfaces .....	8
11. Seasoning checks .....	8
12. Rays .....	8
13. Pores, resin ducts, or magnified fibers .....	9
14. Ink test .....	9
15. Scribe test .....	10
16. Pick test .....	11
17. Splitting test .....	11
18. Longitudinal discolored streaks .....	12
19. Alignment of apexes of annual rings .....	12
Indicators of Spiral Grain on Radial Surfaces .....	12
20. Chipped surface .....	12
21. Length of pores .....	12
22. Pick test .....	12
Measuring Slope of Grain .....	13
Diagonal Grain .....	13
When a Radial Surface is Present .....	13
When a Radial Surface is not Present .....	14

TABLE OF CONTENTS (Continued)

	<u>Page</u>
Spiral Grain .....	15
When a Tangential Surface is Present .....	15
When a Tangential Surface is not Present .....	15
Combined Slope of Grain .....	17
When Radial and Tangential Surfaces are Present .....	17
When Radial and Tangential Surfaces are not Present .....	18
Correction for Taper .....	21
Aids in Measuring Slope of Grain on the Surface .....	21
 <b>PART II -- VENEER</b>	
Detecting Slope of Grain in Veneer .....	22
Slope of Grain in Quarter-sliced Veneer .....	23
Indicators of Direction of Grain with Respect to the Edge, or in the Plane of the Sheet (Diagonal Grain) .....	23
23. Tearing .....	23
Indicators of Direction of Grain with Respect to the Face, or Through the Sheet (Natural or Artificial Spiral Grain) .....	23
24. Fractures .....	23
Slope of Grain in Rotary-cut and Flat-sliced Veneer .....	24
Indicators of Direction of Grain with Respect to the Edge, or in the Plane of the Sheet (Natural or Artificial Spiral Grain) .....	24
25. Tearing .....	24
Indicators of Direction of Grain with Respect to the Face, or Through the Sheet (Diagonal Grain) .....	24
26. Intersection of annual rings with the surface .....	24
Measuring Slope of Grain .....	25
In the Plane of the Sheet .....	25
Through the Sheet .....	25

GUIDE TO DETERMINING SLOPE OF GRAIN

IN LUMBER AND VENEER<sup>1</sup>

By

ARTHUR KOEHLER

Chief, Division of Silvicultural Relations

-----  
SUMMARY

Condensed Guide for Determining Slope of Grain in  
Kinds of Lumber Used in Aircraft Construction

Diagonal Grain

The slope of diagonal grain can usually be determined in rough and surfaced lumber by means of the annual rings (pages 4, 13 and 14). For additional features for use when the annual rings are indistinct or when only tangential surfaces are visible, as in inner plies of laminated beams made of edge-grain lumber, see paragraphs 7 to 10, inclusive.

Spiral Grain

Spiral grain frequently is more difficult to detect than diagonal grain because the features used for that purpose usually are not so distinct as the annual rings. Furthermore, for different kinds of wood different features may have to be considered. Table 1 gives the features by which spiral grain can be detected and measured in different kinds of lumber. In rough lumber it may be necessary, for accurate observation, to smooth off an area with a knife or hand plane. If seasoning checks are not present and splitting is not permissible, look for one of the other features that are listed as indicators of spiral grain of the kind of wood being examined. Having determined the direction in which the grain runs, ascertain its slope as directed on pages 15 to 17.

---

<sup>1</sup>This is one of a series of progress reports prepared by the Forest Products Laboratory relating to aircraft. Results here reported are preliminary and may be revised as additional data become available. (out of print since 1966)

## Condensed Guide for Determining Slope of Grain in

### Kinds of Veneer Used in Aircraft Construction

First, determine what kind of wood the veneer is made of and then determine whether it is rotary cut, flat sliced, or quarter sliced. Next, determine whether the grain slopes excessively with respect to the edge, that is, in the plane of the sheet, by means of one of the features listed in table 5 under the heading "slope with edge" which occurs under quarter-sliced veneer and again under rotary-cut and flat-sliced veneer. If there is any question as to whether the slope is greater or less than the maximum permitted, measure the slope as instructed on pages 22 to 25. If the grain slopes more than is permissible the sheet of veneer should be discarded and no further observations need be made.

If the slope of grain with respect to the edge is within the permissible limit, determine whether it is excessive with respect to the face, that is, through the sheet, by means of one of the features listed in table 5 under the heading "slope through sheet" which occurs under quarter-sliced veneer and again under rotary-cut and flat-sliced veneer. Questionable slopes should be measured as instructed on pages 22 to 25.

It should be possible, after some experience is gained, to decide by visual inspection whether the grain slopes more or less than is permitted, and it should be necessary to use the more precise methods herein described only in border-line or disputed cases.

#### INTRODUCTION

Slope of grain in wood and veneer is a complicated subject. There is no simple and easily understood way of presentation. The purpose of this mimeograph is to provide a thorough guide for recognizing and determining slope of grain. It is intended for the person beginning a study of wood as well as for those further advanced.

Wood inspectors, particularly, must thoroughly understand slope of grain or they cannot make proper decisions. For their use this mimeograph presents a detailed discussion with numerous illustrations.

#### Meaning of Slope of Grain

Slope of grain in lumber refers to the inclination of the fibers, usually with respect to the major axis or one of the longitudinal corners

in a rectangular piece of wood with parallel sides and edges.<sup>2</sup> In veneer slope of grain is with respect to the faces and edges. It applies not only to the inclination of the annual rings<sup>3</sup> but also to the inclination of the fibers in the plane of the annual rings. Figure 1 shows the inclination of the annual rings and of the fibers in the plane of the annual rings with respect to a longitudinal corner of a piece of lumber.

### Objections to Excessive Slope of Grain

The principal objections to excessive slope of grain in lumber, dimension stock, and veneer are that it reduces the strength, it may cause warping with change in moisture content, and it makes it difficult to surface lumber smoothly when planing against the grain (figs. 2, 3, and 5).

## PART I -- LUMBER

### Detecting Slope of Grain

Since the true slope of the fibers on the inside of a piece of wood cannot be seen unless it is properly split, nor can it be directly ascertained by examining only one surface, it is necessary, therefore, to determine component slopes separately in two planes, more or less at right angles to each other and parallel to the direction of the fibers. The component slopes together give the combined, or true, slope. The two planes may be either parallel and at right angles to the annual rings, or at right angles to two adjacent surfaces irrespective of the annual rings, or one of each may be used.

Because the annual rings facilitate determination of slope of grain in the radial plane, and seasoning checks, rays, and splitting facilitate its determination especially in the tangential plane, these two planes of reference are commonly used in lumber and dimension stock for determining

---

<sup>2</sup>"Side" refers to the broad surface and "edge" to the narrow surface at right angles to it. "Longitudinal corner" refers to the line along which a side and edge meet.

<sup>3</sup>"Annual rings" is used to designate the yearly layers of growth in wood as seen on longitudinal as well as transverse surfaces.

the slope of grain.<sup>4</sup> Slope of grain in the radial plane is designated as diagonal grain, and that in the tangential plane as spiral grain.

For some purposes, it is simpler to determine the slope of the fibers on two adjacent surfaces without considering how the annual rings run. This applies particularly when the slope of grain is determined on the sides (without reference to the ends) of a piece of wood that does not have radial and tangential surfaces.

In such a piece of wood it is not strictly proper to refer to the two components of the grain slope as diagonal and spiral grain but rather as the slopes of the fibers on two of its adjacent surfaces. For convenience, however, the slope of the fibers on the surface most nearly radial can be referred to as diagonal grain and that on the surface most nearly tangential as spiral grain.

If the surfaces of a rectangular piece of wood are truly radial and tangential, the determination of the direction of grain is relatively simple in most woods, but if the surfaces are intermediate between these two planes, as they often are, it is more complicated. The discussion that follows under "measuring the slope of grain" therefore gives separate consideration to the two types of surfaces.

The direction in which the grain extends can be determined by a number of features in wood but the determinations most easily applied to some woods and wood products are not necessarily applicable or suitable for others. Hence, a discussion of slope of grain in wood in general requires consideration of all practical methods, and the inspector should apply the method that gives the best combination of accuracy and speed for any particular kind of wood and type of wood product.

### Slope of Grain in the Radial

#### Plane -- Diagonal Grain

Diagonal grain is deviation of the plane of the annual rings from parallelism with the longitudinal axis of a piece of wood. It is due to such natural causes as crook, bulges, butt swell, pitch and bark pockets, blister grain, some types of curly grain, healing over of knots and injuries, and to the common practice of sawing tapered logs parallel to the pith instead of to the bark (fig. 4). For convenience, the slope of grain in the

---

<sup>4</sup>The radial plane corresponds to a strictly edge-grain, vertical-grain, rift-sawn, or quarter-sawn surface (R in fig. 1A); the tangential plane corresponds to a strictly flat-grain, or plain-sawn surface (T in fig. 1A). To avoid repetition of synonymous terms the words "radial" and "tangential" are used here to designate the two principal longitudinal planes, or surfaces, of wood.

radial plane, no matter what its cause, is usually spoken of as diagonal grain. Since diagonal grain is usually more easily detected than spiral grain, examination should first be made for diagonal grain. If its slope is greater than permissible, an examination for spiral grain need not be made.

### Indicators of Diagonal Grain on Radial Surfaces

1. Annual growth rings.--If annual rings are present and distinct they are the best indication of slope of grain in the radial plane since the fibers always run parallel to the plane of the annual rings.<sup>2</sup> If the annual rings are not pronounced, as in sweetgum, water tupelo, yellowpoplar, birch, and basswood, they often can be seen better by tilting the surface to the light and looking along it at an acute angle from the end.

It must be remembered that the annual rings show the slope of diagonal grain directly only on surfaces that are radial or nearly so (fig. 19). On surfaces intermediate between radial and tangential, annual rings show a greater slope, but they can be used to determine the slope of diagonal grain (fig. 20).

2. Pores or magnified fibers.--When definite boundaries to the annual rings are indistinct or are entirely absent, as in many tropical woods, and splitting is not permissible, the direction of the pores, or of the fibers under magnification if the pores are not distinct, may be used to determine the slope of diagonal grain as described for spiral grain in paragraph 13. Resin ducts need not be considered, since species of wood having resin ducts also have distinct annual rings.

3. Boundary between sapwood and heartwood.--Although the outer limit of the heartwood often does not closely follow the annual rings around the tree trunk on cross sections, it usually follows the annual rings fairly well longitudinally, for several feet at least, and is a good indicator of slope of grain on radial surfaces of species that have a marked contrast in color between sapwood and heartwood. There is no such contrast in eastern spruce, western hemlock, noble fir, Port Orford white-cedar, and basswood. The sapwood and heartwood boundary should not be considered on surfaces that deviate considerably from radial.

4. Pitch pockets.--In spruce, Douglas-fir, larch, and pine, the pith side of pitch pockets, which is fairly straight and parallel to the annual layers of growth in edge-grain lumber, can be used to determine the slope of grain. This is helpful in rough lumber of these woods in which the annual rings may not be distinctly visible.

---

<sup>2</sup>If the annual rings run obliquely across the ends so that a strictly radial surface is not present, and spiral or diagonal grain is present, it may appear on longitudinal surfaces as if the direction of the fibers as indicated by other features cuts across the annual rings (figs. 20, 22, and 27) but actually such is not the case in the interior of the piece.



5. Longitudinal discolored streaks.--Pitch streaks, mineral streaks, and some stained areas if much longer than wide, usually indicate the direction of the grain on the radial surfaces, but when the annual rings are distinctly visible they constitute a much better criterion of slope of grain than do such streaks.

6. Ink, scribe, pick, and splitting tests.--These tests are usually not necessary to detect diagonal grain on radial surfaces since in nearly all woods used in airplane construction either the annual rings or the pores are sufficiently distinct to indicate whether any diagonal grain is present. In rough lumber with indistinct annual rings the pick test may sometimes be used to advantage. For methods of applying these tests see paragraphs 14, 15, 16, and 17.

#### Indicators of Diagonal Grain on Tangential Surfaces

7. Frequencies of intersection of annual rings with surface.--If diagonal grain is present it will show in most woods on strictly tangential surfaces by the presence of numerous ellipses or parabolas due to the intersection of the annual rings with the surface (fig. 18). This applies also to round stock on which strictly tangential surfaces can always be found. Figure 22, C, shows slight diagonal grain on a rounded tangential surface.

If there is no truly tangential surface in rectangular stock then the rings will come to a point on the longitudinal corners nearest to and farthest from the center of the tree, if diagonal grain is present (fig. 1,B).

The relationship of the distance between the intersections of a number of rings on a tangential surface or a longitudinal corner to the width of the same rings on the end or truly radial surface is a measure of the slope of grain (table 6).

8. Chipped surface.--Diagonal grain is frequently indicated on tangential surfaces by the chipped appearance when planed against the grain (fig. 5,A). It is not practical to determine the degree of slope thereby, however, and the radial surface should be examined for that purpose.

9. Length of pores or resin ducts.--When diagonal grain is present in a piece of wood, the pores in hardwoods, or the resin ducts in spruce, Douglas-fir, larch, and pine, are cut through slantingly on the tangential surfaces and appear shorter than in straight-grained stock, the visible length decreasing with increasing slope of grain (fig. 6 and table 2). Although the length of the pores or resin ducts on either surface can be used for roughly determining the amount the grain slopes, it is much simpler and more reliable to determine the slope on the radial face. This feature, therefore, on tangential surfaces is more useful as an indication of slope than for evaluating it, except for inner, edge-grain plies of laminated stock in which it is one of the few means available for even approximate determination of slope of grain.

It can be seen from table 2 that when the pores in mahogany or birch are about 0.17 inch, or 4 millimeters, in length and when the resin ducts in spruce are about 0.06 inch, or 1-1/2 millimeters in length, the slope of grain is about 1 in 15. In determining the length of pores at least 10 should be measured and averaged in a local area of a square inch or two. In determining the length of resin ducts as many as possible up to 10 within any particular area under consideration for slope of grain should be measured and averaged.

10. Pick test.--The pick test can be used on tangential surfaces for determining the presence of diagonal grain by the angle that the lower edge of slivers pulled up by a pick make with the surface, but if radial surfaces are visible they give a much more reliable indication. For a more detailed description of the pick test, see paragraph 16.

### Slope of Grain in the Tangential

#### Plane -- Spiral Grain

Spiral grain is a deviation of the direction of the fibers in the plane of the annual rings from parallelism with the longitudinal axis of a piece of wood. It is caused either naturally, particularly by one-way spirial, interlocked, wavy, and curly grain, and knots around which the grain curves; or artificially, in pieces cut obliquely out of straight-grained tree trunks so that the grain in the tangential planes is not parallel to the major axis of the piece.<sup>6</sup> Spiral grain is also produced locally by sawing lengthwise of a log through a crook in the log (fig. 7, B). Any slope of grain in the tangential plane, no matter what the cause, is, for convenience, here referred to as spiral grain. Natural spiral grain usually increases in slope from the center of the tree out. Therefore, for maximum slope of grain in the tangential plane the surface farthest from the center of the tree should be examined. The slope of spiral grain as seen on the surface of a piece of wood farthest from the center of the tree may be either right- or left-handed (fig. 1 and fig. 3). Spiral grain cannot be said to be characteristic of any one species but presumably may occur in any species of hardwood or softwood.

---

<sup>6</sup>Artificial spiral grain can usually be distinguished from natural spiral grain by the fact that in artificial spiral grain the apexes of the parabolas formed by the intersection of the annual rings with the tangential surface when diagonal grain is present line up parallel with the direction of the grain, (fig. 18), whereas when natural spiral grain is present the grain takes a somewhat different course (fig. 32). Artificial spiral grain is of about the same slope on the inner and outer tangential surfaces of a piece of wood, whereas natural spiral grain usually has a greater slope on the outer surface. Consequently a piece of wood having only artificial spiral grain splits in a straight surface radially, but a piece with natural spiral grain when split radially shows a twisted surface.

Occasionally the slope of spiral grain varies back and forth from the center of the tree out, especially at the butt, giving the appearance of mild interlocked grain although the slope is all either left- or right-handed in the same general direction (fig. 8).

Interlocked grain is characteristic of sweetgum, water tupelo, blackgum, sycamore, mahogany, khaya, and many other species of tropical origin. The slope may vary from left, through straight, to right, and therefore may not be maximum on either tangential surface (fig. 9). It may have to be determined on the radial surfaces by the methods described in paragraphs 20, 21, and 22. At present, of all the species characteristically having interlocked grain only mahogany and khaya are used in the form of solid wood in airplane construction.

### Indicators of Spiral Grain on Tangential Surfaces

11. Seasoning checks.--Seasoning checks nearly always extend radially and follow the grain longitudinally. When present, they are a good indication of the direction in which the grain runs on surfaces that are tangential or nearly so, even if diagonal grain is present (fig. 15, A). If the surface, on which a seasoning check appears, deviates considerably from being tangential, the direction of the check on the surface is not a direct indication of the slope of spiral grain, or of the slope of the fibers on the surface (fig. 21), but it can be used to determine the slope of grain if it extends to or can be projected to the end, as explained on page 16. In this respect seasoning checks fall in the same category with radial splits.

Other cracks may occur in wood due to stresses developed in felling trees and due to other causes but they usually cut across the annual rings obliquely, not radially, and often do not follow the grain longitudinally. Cracks or splits, therefore, should be used with caution in determining slope of grain, unless they are known to be seasoning checks. Seasoning checks are particularly helpful in determining slope of spiral grain in rough lumber in which other indicators often are obscure.

12. Rays.--The orientation of the rays as seen on tangential surfaces, in which they appear as lines or dashes, is a reliable indication of slope of grain since the fibers run parallel to the rays. In oak the rays are from a fraction of an inch to several inches long on tangential surfaces. In other native woods with prominent rays they range in length up to the following dimensions on tangential surfaces: sycamore, 1/6 inch; beech, 1/8 inch; and maple, barely 1/16 inch (fig. 10). In other native commercial species the structure of the wood must be magnified to determine the orientation of the rays on tangential surfaces.

The orientation of the rays can be used for determining slope of grain only on surfaces that are tangential or nearly so. On surfaces that deviate considerably from being tangential ray orientation is difficult to trace correctly.

13. Pores, resin ducts, or magnified fibers.--In hardwoods in which the pores are distinctly visible on longitudinal surfaces, as in oak, ash, hickory, pecan, walnut, mahogany, khaya, and birch, the direction of their longest dimension as seen on the surface is a highly reliable indication as to the direction of the grain, since the pores run parallel to the fibers.

In spruce, Douglas-fir, larch, and pine the direction of longitudinal resin ducts indicates the direction of grain since the ducts run parallel to the fibers. The resin ducts appear as brownish lines from a fraction of an inch to several inches in length on the surface (fig. 15, A).

Although the orientation of the fibers in wood is the basic determinant of the direction of the grain, the fiber direction itself cannot be seen on any surface without magnification. A hand lens magnifying 7 to 10 diameters having good illumination is desirable for the purpose.<sup>1</sup> An ordinary reading glass is not strong enough. Even at a magnification of 10 diameters it is nearly impossible to distinguish individual fibers but their orientation is clearly discernible. Figure 12 shows a surface of spruce magnified 7-1/2 diameters.

Even in rough lumber the direction of fibers can be seen on magnified longitudinal surfaces provided that only those not loosened from their original position are considered. Such undisturbed groups of fibers usually can be found in depressions where overlying disturbed fibers have been torn out by the saw.

Determination of slope of fibers on the surface, whether strictly tangential or not, is facilitated by viewing them through a piece of flat glass on which a line is drawn parallel and near to a straight edge. By rotating the glass until the line appears parallel to the fibers, the apparent slope of the grain on the surface can then be indicated by drawing a line on the wood along the edge of the glass.

The orientation of pores, resin ducts, or fibers on the surface gives their orientation only on that surface and not necessarily the slope of spiral grain unless the surface is tangential or nearly so. The slope of the fibers on surfaces deviating up to 45 degrees from tangential, however, can be used to determine the slope of spiral grain if the grain can be traced to the end so that the orientation of the annual rings can be seen (fig. 21).

14. Ink test.--In those softwoods which do not have resin ducts and in those hardwoods in which the pores and rays are so minute as to be seen only with the aid of a magnifying glass, an ink test may be helpful in ascertaining the grain slope. This test is made by drawing a fairly heavy line across the surface of a board with some solution which flows readily along the grain. There undoubtedly are a number of solutions which are satisfactory. An alcohol solvent (about 3/4 alcohol and 1/4 water) and a

---

<sup>1</sup>A hand magnifier magnifying about 7 diameters and with a built-in light operated either by dry cells in the handle or from an electric light current can be obtained for about \$21.00, if a preference rating of AA-3 or better can be secured (fig. 11).

dye, such as safranin, gives good results. Equally good, if not better, results can be obtained by using certain commercial fountain-pen inks, that are of the quickly penetrating variety. Ordinary black ink is not satisfactory as it does not flow adequately along the grain.

The amount of solution to be used can be determined only by trial. Sometimes making a rather wide line with a coarse pen is sufficient, while at other times it may be desirable to apply the solution with a medicine dropper drawing the dropper slowly across the piece. As the ink or dye spreads along the fibers many minute lines appear (fig. 13). By drawing an extended line in the general direction of the fine lines formed by the spreading solution, the slope of the grain is more definitely shown.

15. Scribe test.--This test<sup>8</sup> consists in drawing a sharply pointed steel scribe, in the direction in which the grain seems to run. Enough pressure must be applied so that the point will penetrate the wood slightly and freedom of lateral movement must be enough to allow the point to follow the grain. When properly used, the scribe test is one of the best methods for determining the direction in which the grain runs on a surface of a piece of wood if slight scratching of the surface is permissible.

Figure 14 illustrates four scribes that are satisfactory. In A and B the point trails about 5 inches behind the vertical handle by which it is pulled, giving somewhat greater freedom of lateral movement than can be obtained with C or D. Scribe A has advantages over B in that the handle is swiveled; the point, which is a phonograph needle, can easily be replaced; and the long tapered head on the set screw that holds the phonograph needle in place can be used to line up the direction in which the scribe is pulled with the path it has recently traversed. Scribes B and C are simpler to construct since they are made of one piece of drill rod with one end tapered and hardened. Since the point must be a perfect cone in order to function well, B is more difficult to sharpen properly than C. Scribe D consists of a phonograph needle held in a mechanical pencil. The point follows the grain best if it is inclined 10° to 20° from the vertical toward the direction in which it is pulled.

In using the scribe it is advantageous to make one trial scratch, pulling the scribe in the direction in which the grain appears to run and then making a second scratch near the first one by pulling the scribe in the direction parallel to the first one unless it obviously did not follow the grain. When bands of summerwood deflect the scribe from following the true course of the fibers, a number of short scratches should be made in the springwood only.

---

<sup>8</sup>This test was developed by Cross, Austin, and Ireland of Brooklyn, N. Y., who employed a straight scribe. L. W. Smith of the Forest Service developed the swiveled model which was further modified by the Forest Products Laboratory.

Figure 15 shows a number of scratches made with three of the scribes. Their approximate parallelism for each scribe indicates a high degree of consistency. The way they follow the split, wavy edges of birch veneer (fig. 15, B) indicates accuracy in following the true direction of the grain.

Scratches made by the scribes follow the grain as it runs on the surface and do not necessarily indicate the true slope of spiral grain, unless the surface is tangential or nearly so.

16. Pick test.--Woods without resin ducts or distinct pores, especially in rough lumber, offer unusual difficulties in determining slope of spiral grain. The pick test is often helpful in such cases. It is usually applied to large cants in the rough, green condition so that unsuitable material may be detected and rejected as early as possible, but it is also applicable to dry and dressed lumber in smaller sizes.

The test is applied by means of a narrow chisel or similar small, sharp-pointed hand tool, such as a sharpened screw driver. The tool is pushed into the wood at an angle of about  $45^\circ$  to a depth of not more than  $1/4$  inch and then subjected to a prying action so that the point lifts up a little group of fibers (fig. 16). The general direction of the line of separation between these fibers and the rest of the test piece indicates the slope of grain in the plane of the surface. The approximate slope on the face of a piece can be determined by drawing a line in the direction of the fibers (as determined by the pick test) and measuring the slope with reference to the edge. This test also indicates roughly whether the grain slopes into the piece (par. 22). More often than not the two types of cross grain exist in combination in the same piece rather than singly. The mutilation caused by the pick test limits its recommended use to rough lumber.

17. Splitting test.--A split in wood, especially in the radial direction, usually follows the grain although when made close to an edge or corner it may run out at a steeper slope than the fibers. When this happens, it is likely to be recognized by the appearance of the surface of the split and allowance can be made for the deviation. In wood with interlocked grain a split across the rings cannot follow all of the various directions of the fibers and some must be cut or torn across. Figure 13 shows how splits follow the grain, as indicated by other features.

Splitting should be used as a last resort in testing for slope of grain, unless it can be done on relatively short pieces that can be spared from the ends, since splitting usually mutilates a piece seriously.

To determine the slope of spiral grain the split should be made squarely across the rings, following the rays, with a wedge-shaped tool. Splitting is particularly helpful in determining the slope of spiral grain in pieces that do not have truly tangential surfaces. As a rule, splitting is not necessary to determine the slope of diagonal grain since that is indicated by the orientation of the annual rings.

18. Longitudinal discolored streaks.--Pitch streaks, mineral streaks, and some stains usually extend along the grain for much greater distances than across the grain. If they are sufficiently elongated they usually indicate the direction of the grain, although they hardly can be used to determine the slope within narrow limits (fig. 17). Nevertheless, if such elongated discolorations indicate severe slope of grain, the inspector should apply some of the more reliable methods for determining the slope.

19. Alignment of apexes of annual rings.--As a rule, the lateral boundaries of the annual rings as seen on tangential surfaces are of no value in determining slope of grain. However, when diagonal grain also is present and the successive apexes of the parabolas formed by the intersection of the annual rings with the tangential surface line up in a direction not parallel with the long axis they indicate that artificial spiral grain is present and closer inspection should be made for slope of grain (fig. 18). In wood with natural spiral grain the successive apexes of the emerging annual rings do not follow the grain (fig. 32). Artificial spiral grain may accompany natural spiral grain and increase or decrease its slope.

#### Indicators of Spiral Grain on Radial Surfaces

20. Chipped surface.--Deviations of grain in the tangential plane often can be detected on radial surfaces by the chipped appearance of the surface if planed against the grain, although the degree of slope cannot be determined very well thereby (fig. 5, B). Hardwoods with interlocked grain frequently are chipped on quarter-sawed surfaces in alternate bands an inch, more or less, in width. No matter which way such wood is run through the planer the planing will be against the grain in alternate bands.

21. Length of pores.--When spiral grain is present it runs out on the radial surfaces. On the radial surface, therefore, the pores in hardwoods with spiral grain will appear shorter than the pores in straight-grained wood. Since the actual slope of the grain can be more easily determined on tangential surfaces, short pores on radial surfaces should be considered only as an indication of spiral grain and should not be used to determine the degree of slope except for inner portions of wood with interlocked grain and the inner plies of laminated stock. Paragraph 9 gives the length of pores for different slopes of grain. The length of resin ducts on radial surfaces of spruce, Douglas-fir, and larch is not reliable for determining the slope of spiral grain because several resin ducts usually occur in tangential rows which makes it nearly impossible to measure the length of individual ducts on the radial surface.

22. Pick test.--This test, described in paragraph 16, can be used on radial surfaces to determine whether the grain is straight or runs out, that is, whether spiral grain is present. The degree of slope can be determined approximately by measuring the slope on a large splinter. The pick test is applicable to rough lumber and questionable surfaced lumber with wide radial and narrow tangential surfaces.

## Measuring Slope of Grain<sup>9</sup>

### Diagonal Grain

#### When a Radial Surface is Present

To measure the slope of diagonal grain in a rectangular piece draw a line on a radial surface along an annual ring from one end to the corner toward which the ring slopes, as bo in figure 19, A. The ratio of the distance ab to ao is the slope of diagonal grain. For example, if ab measures 0.8 inch and ao 20 inches, then the slope is 0.8 in 20, or 1 in 25.

If it is desirable to determine the slope of diagonal grain some distance from the ends, as between a' and o, draw a line perpendicular to the corner at a' to the annual ring that comes to the corner at o, as a'b'. The ratio of the distance a'b' to a'o is the slope of grain. It is not necessary to follow the grain to the corner; for example, the ratio of the difference between ab and a'b' to the distance aa' also is the slope of diagonal grain.

For measuring the slope of diagonal grain in the inner plies of laminated edge-grain stock, measure the width of a certain number of rings on the end and the length of the tangential surface in which the same rings intersect the surface. The ratio of the width to the length gives the slope of diagonal grain (table 6).

In a piece round or oval in cross section which does not contain the pith, the slope of diagonal grain can be determined by following an annual ring from its apex on a tangential surface (two tangential surfaces are always present) to the end and across the end, as bco in figure 19, B. The ratio of the maximum radial distance from this ring to the circumference, as ad, to the distance from the end to the apex of the annual ring selected, as ao, is the slope of diagonal grain.

If it is desirable to determine the slope of diagonal grain some distance from the ends of a round or oval piece, that can be done by measuring the deviation of the plane of an annual ring from a line drawn parallel to the central axis, as a'b' in figure 19, B, on a radial surface (two radial surfaces are always present) in a certain distance along the axis, as a'o'. The ratio of distance a'b' to a'o' is the slope of diagonal grain. It may, at times, be preferable to determine the slope of grain in half of the diameter or the entire diameter. The diameter can easily be measured with a caliper.

---

<sup>9</sup>The instructions for measuring diagonal, spiral, and combined slope of grain refer to pieces with parallel sides. For measuring slope of grain in tapered pieces see page 21.



When a Radial Surface  
is not Present

When a rectangular piece does not have a truly radial surface, trace an annual ring from one of the two corners, on which the rings run to a point, to the end; as bo in figure 20, and then across the end, as bc. On the end, draw a line from the corner to the ring in a radial direction, or nominally at right angles to the annual ring, as ad. The ratio of the distance ad to ao gives the true slope of diagonal grain.

The slope of diagonal grain can also be determined by multiplying the slope of the annual rings on the surface by the sine of the angle that the rings make with the surface, as seen on the end. For example, if the slope of the annual rings on the surface is 1 in 10 with respect to a longitudinal corner, and the rings make an angle of  $60^\circ$  with the surface on the end, the true slope of diagonal grain is 0.866 in 10, or 1 in 11.5, 0.866 being the sine of  $60^\circ$  as determined from trigonometric tables of functions of angles. On surfaces that are not radial, the slope of the annual rings is always greater than the true slope of diagonal grain within the piece irrespective of whether spiral grain is present.

If it is desirable to measure the slope of diagonal grain some distance from the ends, then from one of the two longitudinal corners to which the rings run to a point, draw a perpendicular line 1 or 2 inches or other units in length on that adjacent surface on which the annual rings appear widest, as a'b', figure 20. From the end of this line follow an annual ring to the longitudinal corner, as b'o, follow it back on the other adjacent surface to a line at right angles to the longitudinal corner, at the point a', as a'c'. Measure the distance a'c', which will be less than a'b'. With a'b' equal to 1 or 2 inches or other units, and the length of a'c' known, the length of the imaginary radial line a'd' can be determined from table 3. The slope of grain can be expressed as the ratio of the distance a'd' to a'o. In this case a'd' is equal to the sine of the angle of which a'c' is equal to the tangent when a'b' = 1. It is not equal to the square root of the sum of the squares of a'b' and a'c', and therefore table 4 does not apply here.

Since it is difficult to determine, except by splitting, whether spiral grain also is present when the diagonal grain runs out at a longitudinal corner, and since it is virtually impossible similarly to measure spiral grain alone some distance from the end, it may be better to forget about diagonal and spiral grain and instead determine the true slope of the fibers on two surfaces adjacent to the longitudinal corner toward which the grain runs out, as directed for combined slope of grain on page 18.

## Spiral Grain

### When a Tangential Surface is Present

Select the tangential surface farthest from the center of the tree as indicated by the curvature or the outer boundaries of the annual rings on the end.

To measure the slope of spiral grain in a rectangular piece, draw a line on the tangential surface parallel to the direction of the grain, as determined by the most applicable of the methods described in paragraphs 11 to 16, from one end to the longitudinal corner toward which the grain slopes, or to a line parallel to it, as bo in figure 22, A or 22, B. The ratio of the distance ab to ao is the slope of grain. For example, if ab measures 1.2 inches and ao 18 inches, then the slope is 1.2 in 18, or 1 in 15.

If it is desirable to determine the slope of spiral grain some distance from the ends, as between a' and o, figure 22, A, draw a line perpendicular to the corner at a' to a line parallel to the slope of the grain extending to o, as a'b', in which case the ratio of the distance a'b' to a'o is the slope of grain. It is not necessary to follow the direction of the fibers to the corner, for example, the ratio of the difference between ab and a'b' to the distance aa' also is a measure of the slope of spiral grain.

In a piece round or oval in cross section the slope of the grain on the outer tangential face (which is always present) with respect to the long axis or a line parallel to it gives the slope of spiral grain, as ab to ao in figure 22, C.

If splitting is permissible, it often is simpler to split off a piece, in which case the split must be started on a radial line, as bc in figure 22, A and b'c' in figure 22, C. The ratio of the maximum width of the piece split off to its original external length, if the split followed the grain, is the slope of spiral grain. If the split did not follow the grain to the point, a correction should be made for it as accurately as possible.

### When a Tangential Surface is not Present

When a rectangular piece of wood does not have a truly tangential surface, select the surface which is most nearly tangential, as indicated by the orientation of the annual rings on the end or the greatest width of annual rings on the surface. This will also be the surface farthest from the center of the tree. If seasoning checks are not present, determine the direction of the grain on this surface by the most applicable method described in paragraphs 13 to 16. Draw a line parallel to the direction of the grain

from the longitudinal corner which is next to farthest from the center of the tree to the end toward which the grain runs, as ob in figure 21. This line will cut across the annual rings on the surface, unless diagonal grain of a particular slope is also present, as indicated in figure 27.

On the end drop a perpendicular line from b (fig. 21), to the annual ring that extends to the corner at o, which will also meet the corner at a if no diagonal grain is present, as bd. The line do represents the true direction of the fibers within the piece because it is in a vertical plane parallel to the direction of the fibers on the surface and in a plane of an annual ring, both of which extend to o. The ratio of the distance ad to ao is the slope of spiral grain.

The true slope of spiral grain also can be determined by dividing the slope of the fibers on the surface by the cosine of the angle that the rings, as seen on the end, make with the same surface. For example, if the slope of the fibers on the surface is 1 in 10 with respect to a longitudinal corner, and the rings make an angle of 30° with the surface on the end, the true slope

of spiral grain is  $\frac{1}{0.866} = 1.155$  in 10, or 1 in 8.66, 0.866 being the cosine of 30° as determined from trigonometric tables of functions of angles. On surfaces that are not tangential, the slope of the fibers always is less than the true slope of spiral grain within the piece if diagonal grain is not present. If diagonal grain is present it may be greater or less.

If a line is drawn parallel to a seasoning check (par. 11), as b''o, in figure 21, the line on the end must be extended radially (not perpendicularly from the surface) to the annual ring that comes out at o, as b''d. The same result also can be obtained by multiplying the slope of a seasoning check on the surface by the cosine of the angle the annual rings, as seen on the end, make with the same surface. For example, if the slope of a seasoning check is 1.33 in 10 with respect to a corner, and the rings make an angle of 30° with the surface on the end, the true slope of spiral grain is  $1.33 \times 0.866 = 1.155$  in 10, or 1 in 8.66. On surfaces that are not tangential, the slope of seasoning checks always is greater than the true slope of spiral grain within the piece irrespective of whether diagonal grain is present.<sup>10</sup>

If it is desirable to determine the slope of spiral grain without reference to the end, this can be done by determining the slope of the fibers (not seasoning checks) on two adjacent surfaces toward a common point on the corner on which the grain runs out, as b'o and c'o, in figure 21. The slope of spiral grain (if no diagonal grain is present) is the ratio of the length of the imaginary line a'd' to a'o. The length of the line a'd' is equal to the square root of the sum of  $(a'b')^2$  and  $(a'c')^2$ . Table 4 can be used for determining the resultant slope without complicated calculations. This method is the same as that described for determining the combined slope of diagonal and spiral grain on page 19.

---

<sup>10</sup>This statement assumes that the actual slope of spiral grain does not increase appreciably within the piece of wood, as it might if the slope is determined on the surface nearer to the center of the tree or in wood with interlocked grain.

If it is permissible to split the wood to determine the slope of spiral grain, split off that one of the two corners which is neither farthest from nor nearest to the center of the tree toward which the grain runs out, starting the split along a radial line, as b''c'' in figure 21. If the split runs out at a steeper slope than the grain near the point, as at o, as frequently happens, the point o must be located by projecting the straight portions of the split surfaces. The ratio of the maximum thickness of the portion split off, as ad, to its length, as ao, is the slope of spiral grain.

#### Combined Slope of Grain

If both spiral and diagonal grain are present in a piece of wood, either the slope of each may be determined separately and the combined slope determined therefrom or the combined slope may sometimes be determined directly.

#### When Radial and Tangential Surfaces are Present

On the radial surface trace an annual ring from a longitudinal corner where it runs out some distance from the end, to the end, as oc, in figure 23. Next determine the direction of spiral grain on the tangential surface and draw a line parallel to it from o to the end, as ob. On the end, draw a radial line from b to the annual ring that comes out at o, as bd. The line do represents the true slope of the fibers in the piece because it is in a radial plane and in a tangential plane to both of which the fibers are parallel, and the ratio of the distance ad to ao represents the combined, or true, slope of grain. If desirable, the combined slope may also be obtained by determining the slope of diagonal and spiral grain separately and referring to table 4.

If measurement of the slope of grain is made without reference to the end surface, as between a' and o in figure 23, the slope of diagonal grain, as a'c' in a'o, and the slope of spiral grain, as a'b' in a'o must be determined separately. The combined, or true, slope can then be calculated by taking the square root of the sum of the slope of diagonal grain squared and the slope of spiral grain squared. To avoid making complicated calculations the combined slope for various slopes of diagonal grain and spiral grain is given in table 4.

The principle involved is illustrated in figure 23 in which ad represents the slope of grain in the distance ao. Since ad is the diagonal of a rectangle, two adjacent sides of which are ab and ac, it is equal to

$$\sqrt{(\underline{ab})^2 + (\underline{ac})^2} .$$

If splitting is permitted, split off a wedge-shaped piece directly across the rings, as along be, in figure 23. From one of the points of the wedge trace an annual ring back to the end on the split surface, as do.

This line represents the true direction of the fibers and the ratio of ad to ao represents the true slope of the fibers within the piece with respect to a longitudinal corner and the longitudinal axis if the piece is not tapered.

### When Radial and Tangential Surfaces are not Present

Since it is easy to determine whether diagonal grain is present even when no radial surfaces occur on a piece of wood, as described on page 14 and shown in figure 20, the slope of diagonal grain should first be determined, and if it is greater than the amount permissible no further examination for spiral grain or combined slope of grain need be made.

If splitting is not permissible, proceed as follows:

Since it is extremely difficult to determine without splitting whether spiral grain is present if diagonal grain is present, it is best to disregard spiral grain in wood without tangential surfaces and determine the combined slope directly. To do this, find out toward which of the four longitudinal corners the grain slopes on two adjacent surfaces. This can be done most simply by selecting one of the two corners toward which the annual rings slope to a point, as ap in figure 24, and determining the slope of the fibers by the most applicable of the methods described in paragraphs 13 to 15 (the annual rings, seasoning checks, or rays will not do for this purpose) on that one of the two adjacent surfaces which is most nearly tangential as app'a'. If the slope of the fibers on the surface, as mn, with respect to the corner selected is less than that of the annual rings on the surface, as bo, near the longitudinal corner, the slope of the fibers in the interior is toward the same corner. If the slope of the fibers, as m'n', is greater than but in the same direction as that of the annual rings, the slope of the fibers in the interior is toward the corner a"p". If the slope of the fibers, as m"n", is in the reverse direction, namely, toward the corner a'p', the slope of the fibers in the interior is toward that corner also.

Having found the longitudinal corner toward which the grain actually slopes, on that one of the adjacent surfaces which is most nearly tangential draw a line parallel to the direction of the fibers from the corner toward the end, as bo, in figures 25 or 26. On the end surface draw a line, as bd, perpendicular to the longitudinal surface, to the annual ring that runs out at o, as ef. An imaginary line connecting d and o indicates the true direction of the fibers since it is at the intersection of the plane of an annual ring and a vertical plane parallel to the direction of the fibers on the surface. The ratio of the distance ad to ao is the true, or combined, slope of grain.

If it is desirable to determine the combined slope of grain some distance from the ends so that it is not practical to refer to them, draw a line parallel to the direction of the fibers (not annual rings or seasoning checks) on each of the surfaces adjacent to the longitudinal corner toward

which the fibers slope to a common point on the corner, as b'o and c'o in figures 25 or 26. The ratio of the distance a'b' to a'o is one surface component of the true slope of the fibers and the ratio of a'c' to a'o is the other component. These do not represent spiral and diagonal grain in this case. The combined, or true, slope is the square root of the sum of the squares of the two slopes. Consult table 4 for determining the combined slope as though for spiral and diagonal grain. The same procedure could be applied at the end, but is simpler to use an annual ring as a plane of reference on the end than to find the slope of the fibers on the surface which is more nearly radial.

In occasional pieces the fibers may appear to slope toward a longitudinal corner on one surface, as bo, figure 27, and be parallel to the corner on the adjacent surface, as eh. Then the combined slope of diagonal and spiral grain (both are present if the annual rings run diagonally across the end) is expressed by the ratio of the distance ab to ao, or a'b' to a'o if the slope is measured without reference to the end. The slope of the fibers on one surface coincides with the true slope in this case and is parallel to an annual ring on that surface, as bo. The slope of diagonal grain is represented by the ratio of ad to ao, and the slope of spiral grain by bd to ao. Being the hypotenuse of a right-angled triangle, the combined slope,

$$\underline{ab}, = \sqrt{(\underline{ad})^2 + (\underline{bd})^2}, \text{ all with respect to the distance } \underline{ao}.$$

If splitting is permissible, proceed as follows:

Method 1. Of the two longitudinal corners which are neither farthest from nor nearest to the center of the tree, split off that one toward which the spiral grain runs out, being sure to start the split along a radial line, as bc in figure 28, A or 29, A. Measure the maximum thickness of the piece split off, as ae, figure 28, B or 29, B, and the distance along the original corner from the end to where the split runs out, as ao. The ratio of the distance ae to ao gives the slope of spiral grain. If the split surface does not follow the grain all the way but turns out near the corner, make allowance for that in determining the position of the point o.

Next, select the longitudinal corner which is farthest from or the one which is nearest to the center of the tree toward whichever the diagonal grain runs out, as a'o', figures 28, A or 29, A. It is not necessary to split off the corner but instead the slope of diagonal grain is indicated by the ratio of the radial distance a'd' to a'o'. The combined, or true, slope is the square root of the sum of the squares of the two slopes (table 4).

Method 2. If it is desirable to determine the combined slope of grain on the same longitudinal corner, as might happen in wide pieces or if only one corner may be mutilated, make a radial split at the corner toward which the spiral grain runs out, as along bc, figure 28, A.

If one of the annual rings visible on the split surface extends to the apex, draw a line on the piece split off along that annual ring from the apex to the end, as do, figure 28, B. This line represents the true direction of

the fibers because it lies at the intersection of a radial plane (the split surface) and a tangential plane (tangent to an annual ring), both of which are parallel to the fibers. Since the line do runs out on the corner ao, the true, or combined, slope of grain is the ratio of the distance ad to ao. If no diagonal grain were present, the annual ring ae would come out at o. Therefore, de, which is equal to a'd' if a'o' equals ao, represents the slope of diagonal grain, and since ae represents the slope of spiral grain, the combined slope, ad, being the hypotenuse of a right-angled triangle, ade, is equal to the square root of the sum of the squares of spiral and diagonal grain, or  $\sqrt{(ae)^2 + (de)^2}$  all with respect to the distance ao. This is cited merely as proof, since the calculations indicated are not necessary, as the combined slope is determined directly.

If method 2 is used and none of the annual rings on the split surface run out at the apex, as in figure 29, A, it means that the grain within the piece slopes to one of the adjacent longitudinal corners, as a'o', but the slope can be determined on the split corner as follows:

On the split surface of the piece split off, draw a line from the annual ring on the end that extends to the corner, as ae, figure 29, B, to the apex of the splinter, namely o. That is the direction the annual rings would take if no diagonal grain were present. Determine the midpoint of the line eo, as o'', and draw a line parallel to the annual rings from o'' to the end, as o''c'. Twice the distance c'e represents the slope of diagonal grain in the length ao. The slope of spiral grain in the same length is represented by the distance ae, and the combined slope is the square root of the sum of the squares of the two slopes (table 4).

An alternative is to determine the combined slope of grain on either the longitudinal corner that is farthest from or the one that is nearest to the center of the tree, on whichever the annual rings run out. Split off that corner along an annual ring, as bco, figure 30, A. Determine the direction of the grain on the split surface of the piece split off, by the most applicable of the methods for determining slope of grain in the tangential plane, as given in paragraphs 11 to 15. Draw a line parallel to the direction of the grain from o toward the end, as od. This line represents the true direction of fibers because it is in the plane of an annual ring and parallel to the direction of the fibers in that plane, and, since it runs out at o, the ratio of the distance ad to ao represents the true, or combined, slope of grain.

It does not follow that the combined slope of grain can always be determined by splitting off one of the corners farthest from or nearest to the center of the tree, since if no line parallel to the fibers passes through o on such corners, it means that the slope must be determined on one of the corners neither farthest from nor nearest to the center of the tree, as in figure 28. Therefore, it is preferable to begin by splitting off one of the corners neither nearest to nor farthest from the center of the tree since, on account of the edge view of the annual rings there, it can quickly be determined toward which corner the fibers actually are inclined.

## Correction for Taper

When a piece of wood is uniformly tapered, one-half of the taper must be subtracted from or added to (whichever gives the proper correction) the slope of grain as determined with respect to a surface or longitudinal corner. The taper must be measured in the plane in which the slope of grain is measured. If only spiral grain is present the taper must be measured in the tangential plane, and if only diagonal grain is present it must be measured in the radial plane, through the central axis, whether these planes are parallel to a surface, run diagonally from corner to corner, or are oriented between the two. If the combined slope of grain is measured directly, the taper must be measured in the plane in which combined slope lies.

### Aids in Measuring Slope of Grain on the Surface

Whether the slope of diagonal or spiral grain in pieces with radial and tangential surfaces, or the slope of the fibers on any surface is acceptable or not, can be determined rather simply by using a piece of glass or transparent plastic with lines on it indicating the maximum permissible slopes of grain. On such a transparent plate a middle line should be drawn perpendicular to one edge, and on each side of the middle line one should be drawn a short distance from it having the maximum permissible slope to the right and to the left, respectively<sup>11</sup> (fig. 31). By placing the squared edge of the glass against a square, the other arm of which is lined up with the side or edge of the board (fig. 11) it can quickly be determined whether the slope of grain on any surface is greater than the maximum permissible in any portion of the board that can be covered by the square. If the slope of grain on one surface is greater than the amount permissible, the slope on other surfaces need not be considered. If truly radial and tangential surfaces are not present, the annual rings and seasoning checks cannot be used for this purpose. The direction of the fibers on the surface must be ascertained instead.

If the combined slope of grain is to be determined, a similar device, with lines indicating slopes from 1 in 30 to 1 in 5, by intervals of 5 units, to the right and to the left can be used for determining the slope of the fibers on each of two adjacent surfaces by proper interpolation between the lines (fig. 31). From the two individual slopes the combined slope can be determined by the use of table 4.

---

<sup>11</sup>Instead of drawing the lines directly on glass they may be drawn on paper or tracing cloth, photographed, and positives made on a glass plate or thick film. An emulsion and developer which makes clear high lights should be used.



The slopes of grain may also be determined in degrees with a protractor. The length of the piece in which the slope of grain deviates one unit from parallelism with the axis is equal to the cotangent of the angle, as determined from trigonometric tables of function of angles. For example, if the grain slopes  $3\text{-}1/2$  degrees, it deviates 1 inch in 16.35 inches, 16.35 being the cotangent of  $3^{\circ} 30'$ .

## PART II -- VENEER

### Detecting Slope of Grain in Veneer

In veneer and plywood the slope of grain is determined with respect to the edge, that is, in the plane of the sheet, and with respect to the face, that is, through the sheet, irrespective of whether the surfaces are truly radial or tangential. In rotary-cut veneer the face is virtually a tangential surface and the edge a radial surface, but in sliced veneer the face and edge may be either, or intermediate.<sup>12</sup>

Nearly all of the features described in paragraphs 1 to 22 in Part I for detecting the slope of grain in lumber can also be used in veneer, although the pick test is not applicable to thin veneer. Additional features or methods not applicable to lumber are here described.

---

<sup>12</sup>Rotary-cut veneer can be recognized by the fact that the knife marks extend more or less at right angles to the edges and the pattern of the annual rings often weaves back and forth for considerable distances across the face of the sheet forming several series of ellipses or parabolas (fig. 32). Usually the rays extend through the veneer at right angles to the face as seen with a magnifying glass on a smoothly cut end. In sliced veneer the knife marks extend more or less diagonally across the grain (fig. 33). In flat-sliced veneer the annual rings do not extend long distances across the face of the sheet, but at most they describe one series of parabolas flanked on both sides by growth layers narrowing toward the edges (fig. 33). The rays run through the veneer at angles of  $90^{\circ}$  to  $45^{\circ}$ , or less, with the face. In quarter-sliced veneer the annual rings appear as narrow, more or less parallel bands running lengthwise of the sheet, making an angle of  $45^{\circ}$  to  $90^{\circ}$  with the face of the sheet as seen on the end. The rays run more or less parallel to the face, rarely deviating therefrom more than  $45^{\circ}$ . Knife marks are seen best by side lighting.

## Slope of Grain in Quarter-sliced Veneer

### Indicators of Direction of Grain with Respect to the Edge, or in the Plane of the Sheet (Diagonal Grain)

Slope of grain with respect to the edges of quarter-sliced veneer, which amounts to diagonal grain, can be detected on the face by means of the annual rings, pores, boundary between sapwood and heartwood, pitch pockets, longitudinal discolored streaks, and the scribe, ink, and pick tests, as on radial surfaces of lumber (par. 1, 2, 3, 4, 5, and 6). The ink, scribe, and pick tests are more fully described in paragraphs 14, 15, and 16.

23. Tearing.--If the annual rings are not distinct or the cut deviates considerably from the truly radial plane so that the annual rings do not indicate the true slope of grain with respect to the edge, tearing may be resorted to for determining slope of grain with the following reservations. In sliced veneer the tear is likely to go diagonally across the grain on the face of the sheet if the veneer is torn with one hand pulling down and the other up, whereas if the reverse movement of the hands is used it will follow the grain (fig. 34). This difference in tearing is due to the fine checks produced on the open side, which in sliced veneer run diagonally along the sheet because the flitches usually are put on the log bed of the slicer in an inclined position so that the knife passes diagonally through the flitch. Since these checks follow the rays slantingly into the sheet, the tear will follow the diagonal checks on the face if they are pulled apart but will follow the grain if the pull in tearing is in the opposite direction so as to close them (fig. 35). When severe slope of grain occurs through the sheet a tear also may not follow the grain accurately. Such veneer, however, would usually be thrown out of airplane stock because of "short grain."

### Indicators of Direction of Grain with Respect to the Face, or Through the Sheet (Natural or Artificial Spiral Grain)

Slope of grain through the sheet of quarter-sliced veneer, which amounts to spiral grain, can be detected on the face by means of the length of the pores and the pick test, as spiral grain is detected on radial surfaces of lumber (par. 21 and 22). On the edge it can be detected by the orientation of the rays, pores, resin ducts, and magnified fibers, and the way ink spreads (par. 12, 13, and 14). These features indicate the slope of grain near the edge only, not on the interior of the sheet, but they are the only means for determining the slope of grain in the inner plies of plywood without tearing it apart.

24. Fractures.--When the slope of grain through the sheet approximates 1 in 10, a strip cut from dry veneer, if bent sufficiently, will break diagonally along the grain provided the wood is not brash due to low specific gravity, decay, compression failures, or other causes. The ratio of the

thickness of the veneer to the length of the break measured parallel to the edge and to the face, not diagonally through the sheet, gives the slope of grain through the sheet. The length of the break can be measured either on the face or on the edge (fig. 36). This method will not work well for veneer thinner than 1/32 inch. The width of the strip should be about 1/2 inch and it should be cut parallel to the edge. The break should follow the grain and terminate in a sharp edge on both sides of the veneer. If any part of the break extends across the grain it cannot be used for this purpose and another break should be made. In more nearly straight-grained veneer the break frequently extends more or less across the grain, and hence this method cannot be applied to measuring small slopes of grain. If the grain also slopes with respect to the edge, that should be taken care of separately as so much slope in the plane of the sheet.

### Slope of Grain in Rotary-cut and Flat-sliced Veneer

#### Indicators of Direction of Grain with Respect to the Edge, or in the Plane of the Sheet (Natural or Artificial Spiral Grain)

Slope of grain with respect to the edge of rotary-cut and flat-sliced veneer, which amounts to spiral grain, can be detected on the face by means of seasoning checks, rays, pores, resin ducts, magnified fibers, the ink, scribe, pick, and splitting tests, longitudinal discolored streaks, and the alignment of apexes of annual rings, as spiral grain is detected on tangential surfaces of lumber (par. 11, 12, 13, 14, 15, 16, 17, 18, and 19).

25. Tearing.--Tearing is reliable for determining direction of grain provided serious slope of grain through the sheet is not present.

#### Indicators of Direction of Grain with Respect to the Face, or Through the Sheet (Diagonal Grain)

Slope of grain through the sheet of rotary-cut and flat-sliced veneer, which amounts to diagonal grain, can be detected on the face by means of length of pores and resin ducts and the pick test, as diagonal grain is detected on tangential surfaces of lumber, and by slope of fractures and the intersection of annual rings with the surface in veneer (par. 9, 10, and 24). On the edge it can be detected by the orientation of the annual rings, pores, and fibers, and by the ink test (par. 1, 2, and 14).

26. Intersection of annual rings with the surface.--(a) In rotary and flat-sliced veneer the presence of frequent parabolas, formed by the intersection of numerous annual layers of growth with the surface of the veneer, as described for lumber in paragraph 7, is an indication of considerable slope of grain through the sheet, but they cannot be used very well to determine the exact slope since it is extremely difficult to determine the width of the rings in veneer. If the ring widths can be determined, however,

then the distances between two or several apexes of such parabolas on the surface of the veneer and the widths of the same rings as measured radially across the grain are indicative of the slope of grain, independent of the thickness of the veneer (table 6). For example, if the average width of the annual rings is 0.12 inch and the average distance between successive apexes on the surface is 1.20 inch, the slope of grain is 1 in 10.

(b) If the distance between the apexes of intersection of the same annual ring on the two sides of a piece of veneer can be determined, then the ratio of the thickness of the veneer to that distance gives the slope of grain through the sheet, as ab to ao in figure 36. The distance must be measured in the direction parallel to the face of the veneer, not diagonally through it. The boundary of the same annual ring can be identified on the two sides in thin veneer and the distance measured by holding the veneer against a strong light, marking the boundaries of the ring with a soft, sharp pencil. In thicker veneer the difference can be ascertained by measuring the distances of the apexes from the end, care being taken to use the same annual ring on the two sides. The boundary of an annual ring on one side of veneer also can be indicated on the other side by a pin prick through the veneer.

Table 7 gives the slope of grain for various thicknesses of veneer. For example, if the thickness of veneer is 1/16 inch and the distance between the apexes of the same annual ring on opposite sides is 1/2 inch, the slope of grain is 1 in 8.

### Measuring Slope of Grain

#### In the Plane of the Sheet

After the direction in which the grain runs in the plane of the sheet has been ascertained, its slope with respect to a trimmed edge or a line parallel to it can be measured in the same manner as described for diagonal grain and spiral grain in lumber on pages 13 and 15, and illustrated in figures 19, A, 22, A, and 22, B, or its slope can be determined directly by means of a protractor or other device indicating various slopes of grain, as described on page 21.

#### Through the Sheet

If the slope of grain through the sheet cannot be determined directly on the face by the length of pores or resin ducts or the width of annual rings, as described in paragraphs 9 and 26, measurement may be made on the edge. It is helpful to clamp the edge of the veneer flush between two blocks of wood and with the aid of a magnifying glass draw a line parallel to the grain, as indicated by annual rings, pores, magnified fibers, and ink test (pars. 1, 2, and 14). The ratio of the deviation of this line from the face of the veneer, or a line parallel to it, in a certain distance along the length of the edge is the slope of grain (fig. 36). This method, however, gives only the slope at the edge and is not necessarily reliable for some distance from the edge. The same procedure may also be used for measuring the length of fractures (par. 24).

Table 1.--Features useful for determining slope of spiral grain in lumber on more or less tangential surfaces (unless otherwise stated) in different kinds of wood

Paragraph references in text	11	12	13	13	13	14	15	16,22	17	18	18	18	19	20	21
Kind of wood	Seasoning checks, if present	Ray orientation	Core orientation	Resin ducts	Magnified fibers	Ink test	Scribe test	Block test (tangential and radial surfaces)	Splitting radially, if permissible	Mineral streaks, if present	Pitch streaks, if narrow and long	Alignment of apexes of annual rings if artificial spiral grain is present	Chipped radial surface, if present	Length of pores on radial surface	
Ash, all species	X		X		X	X	X	X	X			X	X	X	X
Baldcypress	X				X	X	X	X	X			X	X	X	X
Basswood	X				X	X	X	X	X	X		X	X	X	X
Beech, American	X	X			X	X	X	X	X			X	X	X	X
Birch, all species	X		X		X	X	X	X	X	X		X	X	X	X
Cedar, Alaska	X				X	X	X	X	X			X	X	X	X
Cherry, black	X		X		X	X	X	X	X			X	X	X	X
Cottonwood	X		X		X	X	X	X	X		X	X	X	X	X
Douglas-fir	X			X	X	X	X	X	X			X	X	X	X
Elm, all species	X		X		X	X	X	X	X			X	X	X	X
Fir, all true fir species	X				X	X	X	X	X			X	X	X	X
Hemlock, western	X				X	X	X	X	X			X	X	X	X
Hickory, all species	X		X		X	X	X	X	X	X		X	X	X	X
Incense-cedar	X				X	X	X	X	X			X	X	X	X
Khaya ("African mahogany")	X		X		X	X	X	X	X			X	X	X	X
Larch, western	X				X	X	X	X	X		X	X	X	X	X
Magnolia, southern	X				X	X	X	X	X		X	X	X	X	X
Mahogany	X				X	X	X	X	X			X	X	X	X
Maple, all species	X	X			X	X	X	X	X			X	X	X	X
Oak, all species	X		X		X	X	X	X	X			X	X	X	X
Pecan	X		X		X	X	X	X	X			X	X	X	X
Pine, all species	X				X	X	X	X	X			X	X	X	X
Redcedar, western	X			X	X	X	X	X	X		X	X	X	X	X
Redwood	X				X	X	X	X	X			X	X	X	X
Spruce, all species	X			X	X	X	X	X	X		X	X	X	X	X
Sweetgum	X				X	X	X	X	X			X	X	X	X
Sycamore	X	X			X	X	X	X	X			X	X	X	X
Tupelo, water	X				X	X	X	X	X			X	X	X	X
Walnut, black	X		X		X	X	X	X	X			X	X	X	X
White-cedar, northern	X				X	X	X	X	X			X	X	X	X
White-cedar, Port Orford	X				X	X	X	X	X			X	X	X	X
Yellowpoplar	X				X	X	X	X	X		X	X	X	X	X

The darker streaks in figured gum, which may be mistaken for mineral streaks, often do not follow the grain.

Table 2.--Length of pores and resin ducts as seen on the tangential surface of wood having various slopes of diagonal grain

Slope of grain	Visible length of pores				Visible length of resin ducts	
	Mahogany		Birch		Sitka spruce	
	Inch	Millimeters	Inch	Millimeters	Inch	Millimeters
1:5	0.06	1.4	0.03	0.7	0.02	0.6
1:10	.11	2.8	.09	2.2	.04	1.0
1:15	.17	4.2	.15	3.7	.06	1.4
1:20	.22	5.6	.20	5.2	.08	2.1
1:25	.28	7.0	.27	6.8	.12	3.1
1:30	.33	8.5	.33	8.3	.18	4.5

Table 3.--Resultant distance of annual ring from longitudinal corner for various surface components, assuming that ring is not curved appreciably

Length of shorter surface component	Resultant when longer surface component is		Length of shorter surface component	Resultant when longer surface component is	
	1 inch	2 inches		1 inch	2 inches
Inch	Inch	Inch	Inch	Inch	
0.05	0.05	0.05	1.05	0.93	
.10	.10	.10	1.10	.96	
.15	.15	.15	1.15	1.00	
.20	.20	.20	1.20	1.03	
.25	.24	.25	1.25	1.06	
.30	.29	.30	1.30	1.09	
.35	.33	.34	1.35	1.12	
.40	.37	.39	1.40	1.15	
.45	.41	.44	1.45	1.17	
.50	.45	.49	1.50	1.20	
.55	.48	.53	1.55	1.23	
.60	.51	.57	1.60	1.25	
.65	.54	.62	1.65	1.27	
.70	.57	.66	1.70	1.30	
.75	.60	.70	1.75	1.32	
.80	.62	.74	1.80	1.34	
.85	.65	.78	1.85	1.36	
.90	.67	.82	1.90	1.38	
.95	.69	.86	1.95	1.40	
1.00	.71	.89	2.00	1.41	

Table 4.-- Combined slope of spiral and diagonal grain

		How to Determine Combined Slope of Spiral and Diagonal Grain																																					
		First, determine slopes of spiral and of diagonal grain separately. To determine the combined, or resultant, slope find the column headed by the greater of the two slopes and in this column locate the figure in line with the lesser of the two slopes as given in the left-hand column. This figure represents the length in inches (or other units) in which the grain deviates 1 inch (or other unit) with respect to the central axis of the piece. Examples: If the slope of spiral grain is 1 in 20 and the slope of diagonal grain is 1 in 25, the combined slope is 1 in 15.6, or if the slope of diagonal grain is 1 in 16 and the slope of spiral grain is 1 in 22, the combined slope is 1 in 13.9.																																					
		Slope of spiral or diagonal grain, whichever is greater																																					
		1-10:	1-11:	1-12:	1-13:	1-14:	1-15:	1-16:	1-17:	1-18:	1-19:	1-20:	1-21:	1-22:	1-23:	1-24:	1-25:	1-26:	1-27:	1-28:	1-29:																		
1-10	7.1	7.1	7.8	8.1	8.5	8.8	9.1	9.5	9.9	10.2	10.6	11.0	11.4	11.8	12.2	12.6	13.0	13.4	13.8	14.1	14.5	14.9	15.2	15.6	16.0	16.3	16.6	17.0	17.3	17.7	18.0	18.4	18.7	19.1	19.4	19.8	20.1	20.5	
1-11	7.4	7.4	8.1	8.4	8.8	9.1	9.5	9.9	10.2	10.6	11.0	11.4	11.8	12.2	12.6	13.0	13.4	13.8	14.1	14.5	14.9	15.2	15.6	16.0	16.3	16.6	17.0	17.3	17.7	18.0	18.4	18.7	19.1	19.4	19.8	20.1	20.5		
1-12	7.7	7.7	8.4	8.7	9.1	9.5	9.9	10.2	10.6	11.0	11.4	11.8	12.2	12.6	13.0	13.4	13.8	14.1	14.5	14.9	15.2	15.6	16.0	16.3	16.6	17.0	17.3	17.7	18.0	18.4	18.7	19.1	19.4	19.8	20.1	20.5			
1-13	8.1	8.1	8.7	9.1	9.5	9.9	10.2	10.6	11.0	11.4	11.8	12.2	12.6	13.0	13.4	13.8	14.1	14.5	14.9	15.2	15.6	16.0	16.3	16.6	17.0	17.3	17.7	18.0	18.4	18.7	19.1	19.4	19.8	20.1	20.5				
1-14	8.4	8.4	9.0	9.4	9.8	10.1	10.5	10.9	11.3	11.7	12.0	12.4	12.8	13.1	13.5	13.9	14.2	14.6	15.0	15.3	15.7	16.0	16.4	16.7	17.1	17.4	17.8	18.1	18.5	18.8	19.2	19.5	19.9	20.2	20.6	21.0	21.3	21.7	22.0
1-15	8.7	8.7	9.3	9.7	10.1	10.5	10.9	11.3	11.7	12.0	12.4	12.8	13.1	13.5	13.9	14.2	14.6	15.0	15.3	15.7	16.0	16.4	16.7	17.1	17.4	17.8	18.1	18.5	18.8	19.2	19.5	19.9	20.2	20.6	21.0	21.3	21.7	22.0	
1-16	9.0	9.0	9.6	10.0	10.4	10.8	11.2	11.6	12.0	12.3	12.7	13.0	13.4	13.7	14.1	14.4	14.8	15.1	15.5	15.8	16.2	16.5	16.9	17.2	17.6	17.9	18.3	18.6	19.0	19.3	19.7	20.0	20.4	20.7	21.1	21.4	21.8	22.1	
1-17	9.3	9.3	9.9	10.3	10.7	11.1	11.5	11.9	12.3	12.6	13.0	13.3	13.7	14.0	14.4	14.7	15.1	15.4	15.8	16.1	16.5	16.8	17.2	17.5	17.9	18.2	18.6	18.9	19.3	19.6	20.0	20.3	20.7	21.0	21.4	21.7	22.1	22.4	
1-18	9.6	9.6	10.2	10.6	11.0	11.4	11.8	12.2	12.5	12.9	13.2	13.6	13.9	14.3	14.6	15.0	15.3	15.7	16.0	16.4	16.7	17.1	17.4	17.8	18.1	18.5	18.8	19.2	19.5	19.9	20.2	20.6	20.9	21.3	21.6	22.0	22.3	22.7	
1-19	9.9	9.9	10.5	10.9	11.3	11.7	12.1	12.5	12.8	13.2	13.5	13.9	14.2	14.6	15.0	15.3	15.7	16.0	16.4	16.7	17.1	17.4	17.8	18.1	18.5	18.8	19.2	19.5	19.9	20.2	20.6	20.9	21.3	21.6	22.0	22.3	22.7	23.0	
1-20	10.2	10.2	10.8	11.2	11.6	12.0	12.4	12.7	13.1	13.4	13.8	14.1	14.5	14.8	15.2	15.5	15.9	16.2	16.6	16.9	17.3	17.6	18.0	18.3	18.7	19.0	19.4	19.7	20.1	20.5	20.9	21.2	21.6	21.9	22.3	22.6	23.0	23.3	
1-21	10.5	10.5	11.1	11.5	11.9	12.3	12.7	13.0	13.4	13.7	14.1	14.4	14.8	15.1	15.5	15.8	16.2	16.5	16.9	17.2	17.6	17.9	18.3	18.6	19.0	19.3	19.7	20.0	20.4	20.8	21.1	21.5	21.8	22.2	22.5	22.9	23.2	23.6	
1-22	10.8	10.8	11.4	11.8	12.2	12.6	13.0	13.3	13.7	14.0	14.4	14.7	15.1	15.4	15.8	16.1	16.5	16.8	17.2	17.5	17.9	18.2	18.6	18.9	19.3	19.6	20.0	20.3	20.7	21.0	21.4	21.7	22.1	22.4	22.8	23.1	23.5	23.8	24.2
1-23	11.1	11.1	11.7	12.1	12.5	12.9	13.3	13.6	14.0	14.3	14.7	15.0	15.4	15.7	16.1	16.4	16.8	17.1	17.5	17.8	18.2	18.5	18.9	19.2	19.6	20.0	20.3	20.7	21.0	21.4	21.7	22.1	22.4	22.8	23.1	23.5	23.8	24.2	24.5
1-24	11.4	11.4	12.0	12.4	12.8	13.2	13.5	13.9	14.2	14.6	14.9	15.3	15.6	16.0	16.3	16.7	17.0	17.4	17.7	18.1	18.4	18.8	19.1	19.5	19.8	20.2	20.5	20.9	21.2	21.6	21.9	22.3	22.6	23.0	23.3	23.7	24.0	24.4	24.7
1-25	11.7	11.7	12.3	12.7	13.1	13.5	13.8	14.2	14.5	14.9	15.2	15.6	15.9	16.3	16.6	17.0	17.3	17.7	18.0	18.4	18.7	19.1	19.4	19.8	20.1	20.5	20.8	21.2	21.5	21.9	22.2	22.6	22.9	23.3	23.6	24.0	24.3	24.7	25.0
1-26	12.0	12.0	12.6	13.0	13.4	13.8	14.1	14.5	14.8	15.2	15.5	15.9	16.2	16.6	16.9	17.3	17.6	18.0	18.3	18.7	19.0	19.4	19.7	20.1	20.4	20.8	21.1	21.5	21.8	22.2	22.5	22.9	23.2	23.6	23.9	24.3	24.6	25.0	25.3
1-27	12.3	12.3	12.9	13.3	13.7	14.0	14.4	14.8	15.1	15.5	15.8	16.2	16.5	16.9	17.2	17.6	18.0	18.3	18.7	19.0	19.4	19.7	20.1	20.4	20.8	21.1	21.5	21.8	22.2	22.5	22.9	23.2	23.6	23.9	24.3	24.6	25.0	25.3	25.7
1-28	12.6	12.6	13.2	13.6	14.0	14.3	14.7	15.0	15.4	15.7	16.1	16.4	16.8	17.1	17.5	17.8	18.2	18.5	18.9	19.2	19.6	19.9	20.3	20.6	21.0	21.3	21.7	22.0	22.4	22.7	23.1	23.4	23.8	24.1	24.5	24.8	25.2	25.5	25.9
1-29	12.9	12.9	13.5	13.9	14.3	14.6	15.0	15.3	15.7	16.0	16.4	16.7	17.1	17.4	17.8	18.1	18.5	18.8	19.2	19.5	19.9	20.2	20.6	20.9	21.3	21.6	22.0	22.3	22.7	23.0	23.4	23.7	24.1	24.4	24.8	25.1	25.5	25.8	26.2

Based on formula: Combined slope of grain =  $\sqrt{(\text{slope of spiral grain})^2 + (\text{slope of diagonal grain})^2}$





Table 6.--Slope of grain through rotary-cut or flat-sliced veneer as determined by the distance between apexes of parabolas formed by the intersections of two or more annual rings with a face, and the radial width of the same rings

Radial width of an annual ring or average of several :	Distance between apexes of parabolas on the face in inches									
	1/4	3/8	1/2	5/8	3/4	1	1-1/4	1-1/2	2	2-1/2
	0.25	0.375	0.50	0.625	0.750	1.00	1.25	1.50	2.00	2.50
Corresponding slope of grain										
Inch	:	:	:	:	:	:	:	:	:	:
0.25	1-1	1-2	1-2	1-2	1-3	1-4	1-5	1-6	1-8	<u>1-10</u>
.17	1-1	1-2	1-3	1-4	1-4	1-6	1-8	1-9	<u>1-12</u>	<u>1-15</u>
.12	1-2	1-3	1-4	1-5	1-6	1-8	<u>1-10</u>	<u>1-12</u>	<u>1-15</u>	1-20
.10	1-2	1-4	1-5	1-6	1-8	<u>1-10</u>	<u>1-12</u>	<u>1-15</u>	1-20	1-25
.08	1-3	1-4	1-6	1-8	1-9	<u>1-12</u>	1-15	1-18	1-24	1-30
.07	1-4	1-5	1-7	1-9	<u>1-11</u>	1-14	1-18	1-21	1-28	1-35
.06	1-4	1-6	1-8	<u>1-10</u>	<u>1-12</u>	1-16	1-20	1-24	1-32	1-40
.05	1-5	1-8	<u>1-10</u>	<u>1-12</u>	1-15	1-20	1-25	1-30	1-40	1-50
.04	1-6	1-9	<u>1-12</u>	1-16	1-19	1-25	1-31	1-38	1-50	1-62
.03	1-8	<u>1-11</u>	1-15	1-19	1-23	1-30	1-38	1-45	1-60	1-75
	:	:	:	:	:	:	:	:	:	:

Underlined slopes are nearest maximum permissible slope.

Table 7.--Slope of grain through rotary-cut and flat-sliced veneer as determined by the distance between the apexes of the parabolas formed by the intersection of the same annual ring with opposite sides of the veneer

		Distance between apexes of parabolas on opposite sides in inches									
Thickness of veneer	-----										
	: 1/8 ; 1/4 ; 3/8 ; 1/2 ; 5/8 ; 3/4 ; 1										
		: 0.125 : 0.25 : 0.375 : 0.50 : 0.625 : 0.75 : 1.00									
Nominal	Decimal	-----									
thick-	thick-	Corresponding slope of grain									
ness	ness	-----									
Inch	Inch	:	:	:	:	:	:	:	:	:	:
1/10	0.095	1-1	1-3	1-4	1-5	1-7	1-8	1-11			
1/12	.080	1-2	1-3	1-5	1-6	1-8	1-9	1-12			
1/14	.068	1-2	1-4	1-6	1-7	1-9	1-11	1-15			
1/16	.060	1-2	1-4	1-6	1-8	1-10	1-12	1-17			
1/20	.047	1-3	1-5	1-8	1-11	1-13	1-16	1-21			
1/24	.040	1-3	1-6	1-9	1-12	1-16	1-19	1-25			
1/28	.034	1-4	1-7	1-11	1-15	1-18	1-22	1-29			
1/32	.030	1-4	1-8	1-12	1-17	1-21	1-25	1-33			
1/48	.020	1-6	1-12	1-19	1-25	1-31	1-38	1-50			
1/84	.011	1-11	1-23	1-34	1-45	1-57	1-68	1-91			
		:	:	:	:	:	:	:	:	:	:

Underlined slopes are nearest maximum permissible slope.

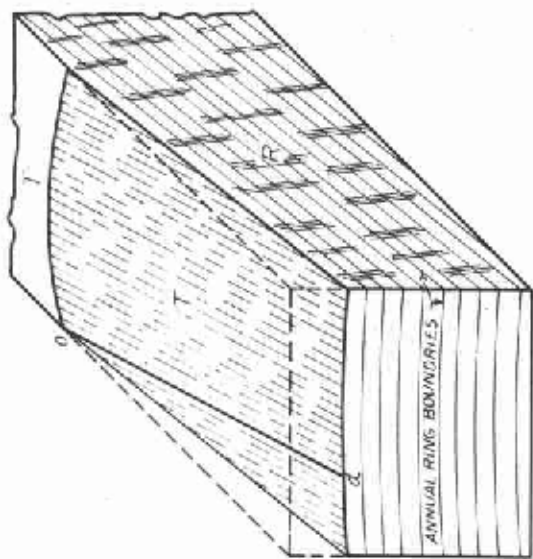

A

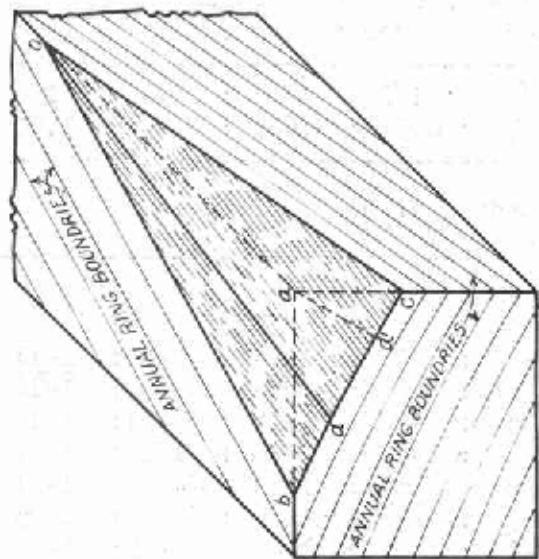

B

Figure 1.—Interior views of two pieces of wood showing inclination of the annual rings (diagonal grain) and inclination of fibers in the plane of the annual rings (spiral grain). The line  $d$  indicates the direction of the fibers in each piece with respect to a longitudinal corner. A, A piece of wood with radial and tangential surfaces and with left-handed spiral grain. R, radial surface, T, tangential surface and with right-handed spiral grain. If spiral and tangential surfaces and with right-handed spiral grain. If spiral grain were not present the direction of the fibers would be parallel to a line from  $d'$  to  $o$ ,  $d'$  being at the base of a perpendicular line from the corner  $a$  to the annual ring  $bc$ .

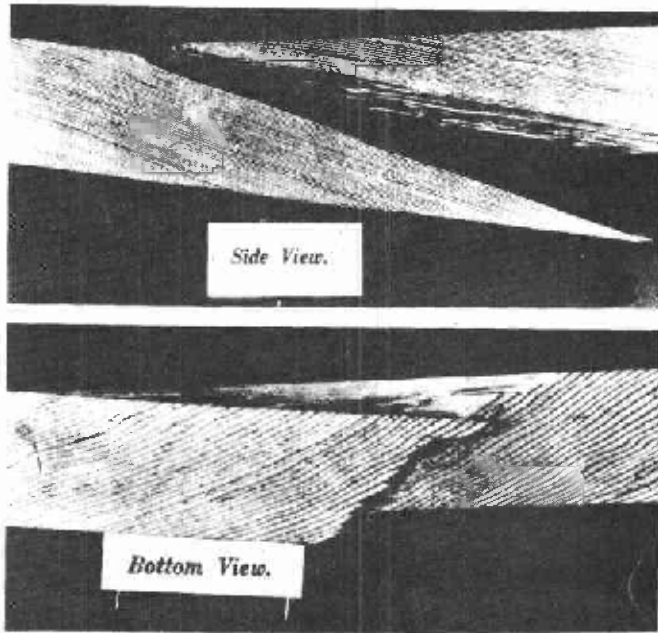

A

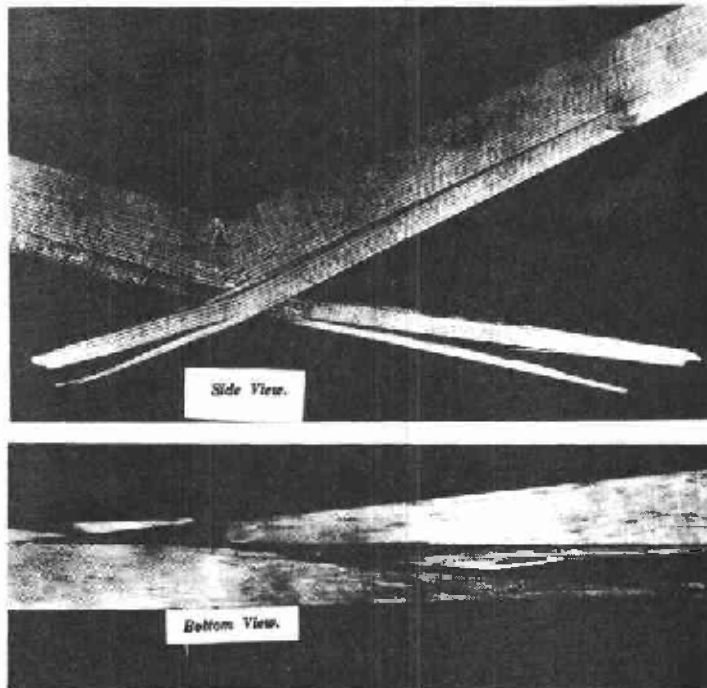

B

Figure 2.--A, Fracture in diagonally grained wood (Douglas-fir);  
B, fracture in spirally grained wood (Sitka spruce).  
Z M 48833 F

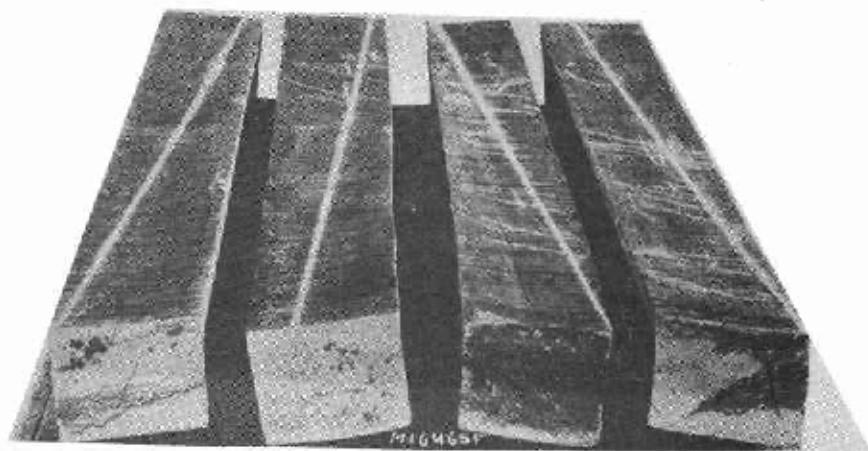
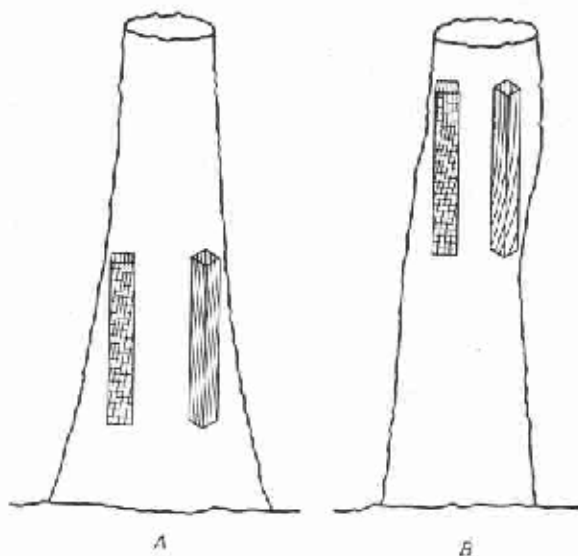

Figure 3.—Twisting of spirally grained wood during seasoning. The two pieces to the left have right-handed spiral grain and the two to the right have left-handed spiral grain, as indicated by the chalk lines on the upper surfaces, which are on the side toward the bark. The lower edges of the farther ends are horizontal (oak).



4 41/07 F

Figure 4.—How diagonal grain may be produced in lumber. A, By not sawing parallel to the bark, especially when the trunk has much taper; B, because of crook in the tree trunk.



A



B

Figure 5.--A, Chipped tangential surface indicating diagonal grain (Sitka spruce); B, chipped radial surface indicating spiral grain (Sitka spruce).

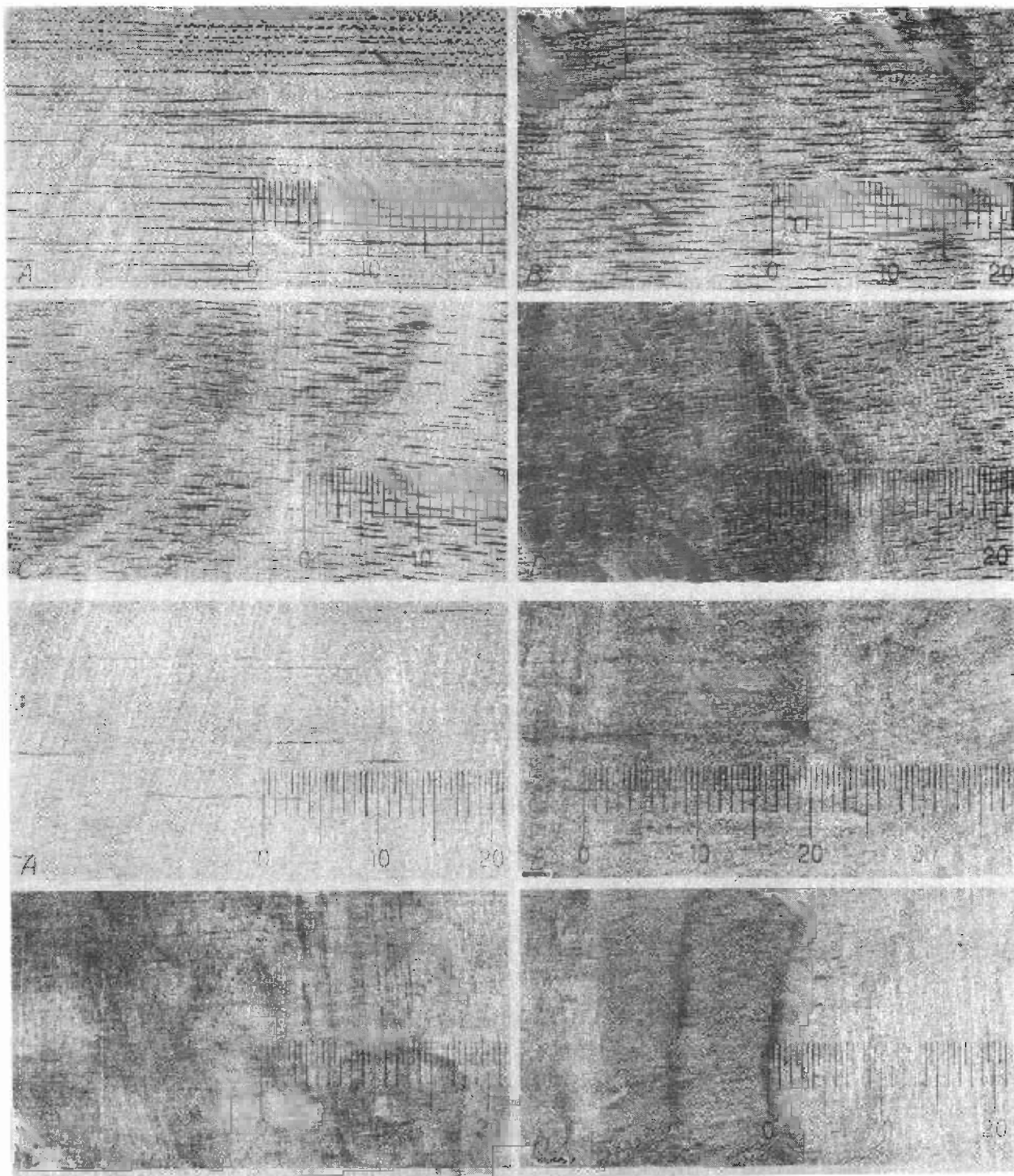

Figure 6.—Comparative length of pores on tangential surfaces of mahogany (top four illustrations) and of resin ducts on tangential surface of Sitka spruce (bottom four illustrations) with following slopes of diagonal grain: A, straight; B, 1-20; C, 1-10; and D, 1-5. The smallest division on each scale represents 1/2 millimeter.

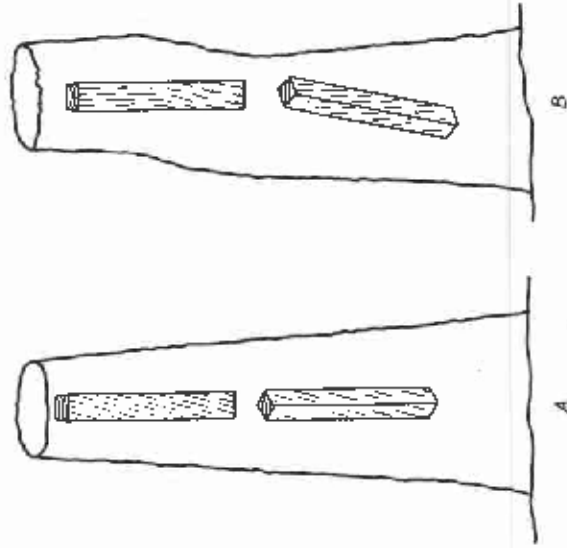

Figure 7.--How spiral grain may be produced in lumber.  
 A, As a result of spiral arrangement of the fibers in the tree trunk -- natural spiral grain; B, because of crook in a tree trunk -- natural spiral grain, or not sawing parallel to the direction of the fibers, even when the trunk is not spirally grained -- artificial spiral grain.

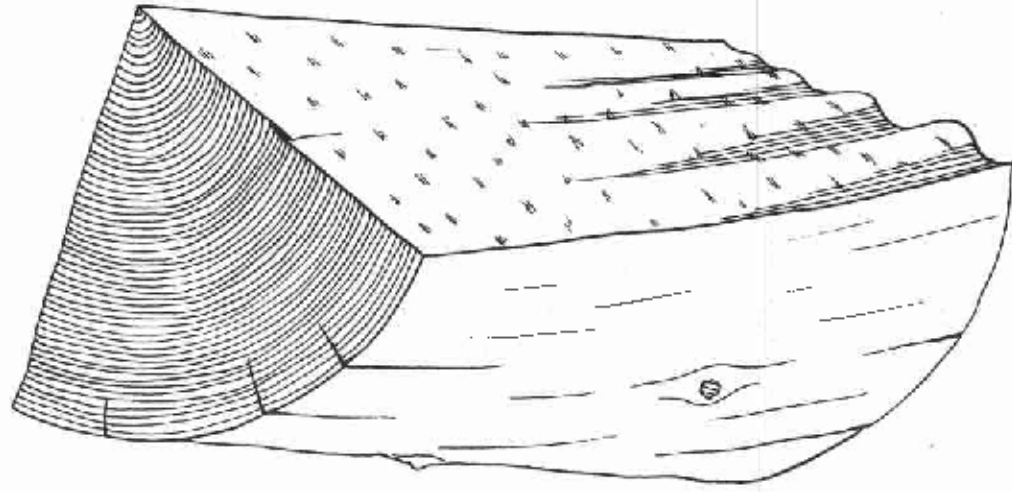

Figure 8.--Spiral grain of varying slope in the same general direction simulating interlocked grain, often found at butt of tree.



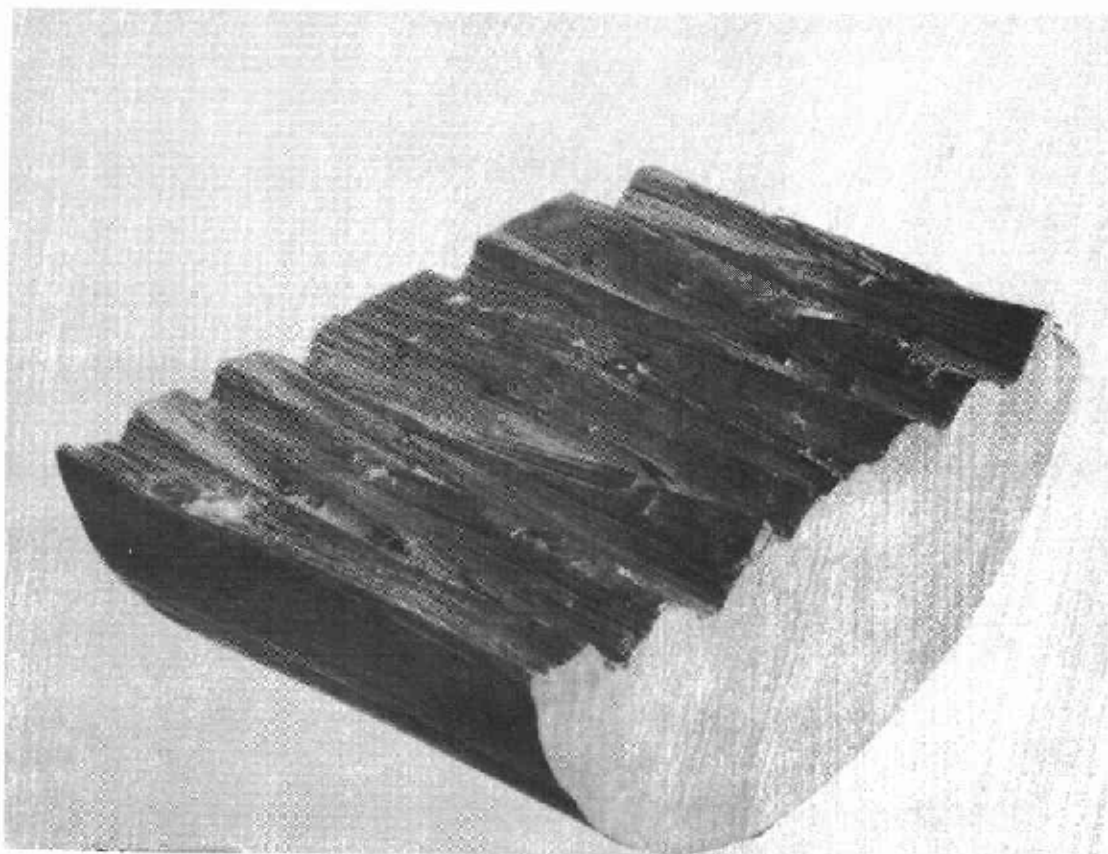
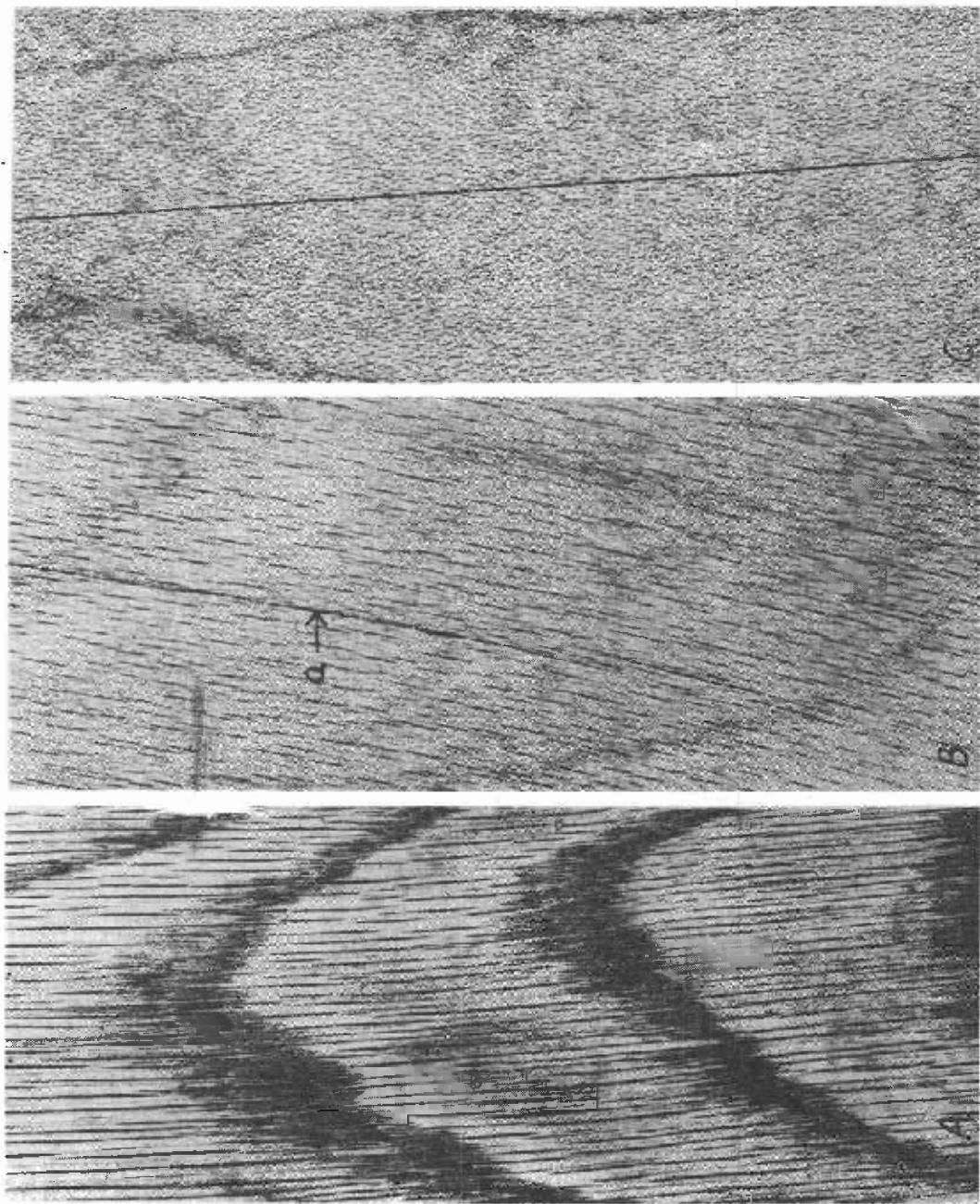

Figure 9.--Interlocked grain as indicated by split radial surface (black tupelo).

Z M 48838 F



**Figure 10.**---Orientation of rays on a tangential surface indicating direction of grain. A, Red oak, natural size (the rays are the dark lines 1 inch, more or less, in length); B, beech, magnified 3 times (the rays are the dark dashes 1/4 inch, more or less, in length) parallel to seasoning check (a); C, sugar maple, magnified 3 times (the rays are the dark dashes, 1/16 inch, more or less, in length), the ruled line is drawn parallel to the rays and indicates the direction of the grain.

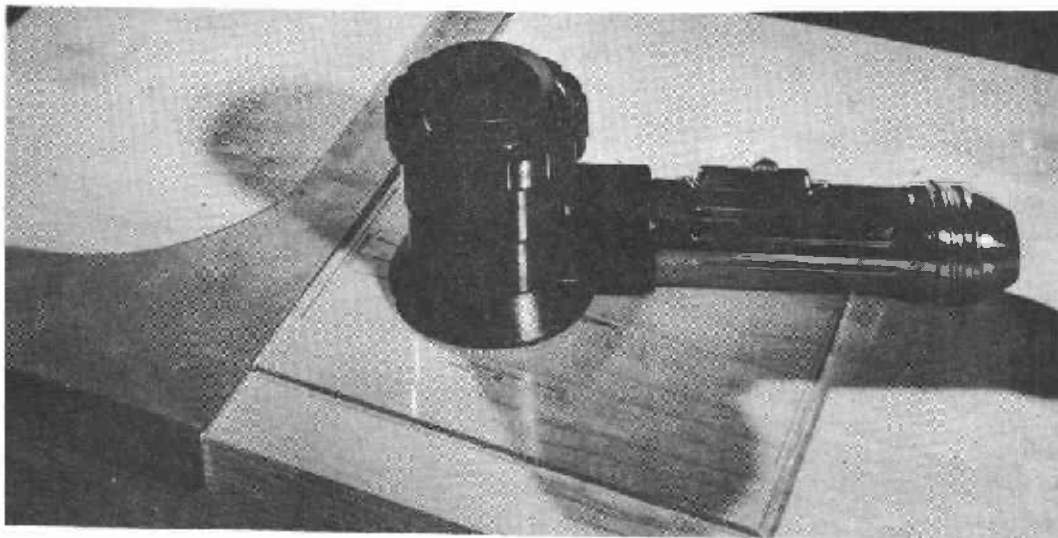
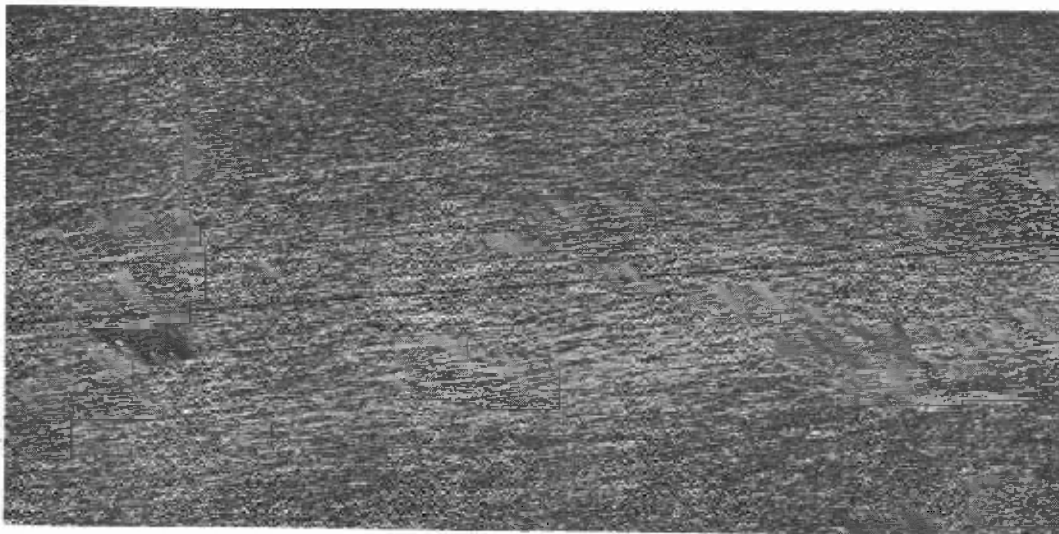

Figure 11.--Illuminated hand magnifier set over ruled glass, lined up with edge of lumber by means of a square, to determine slope of fibers.



2 M 48840 F Figure 12.--Tangential surface of Sitka spruce showing fibers magnified  $7\frac{1}{2}$  diameters. The ruled line is drawn parallel to the fibers.

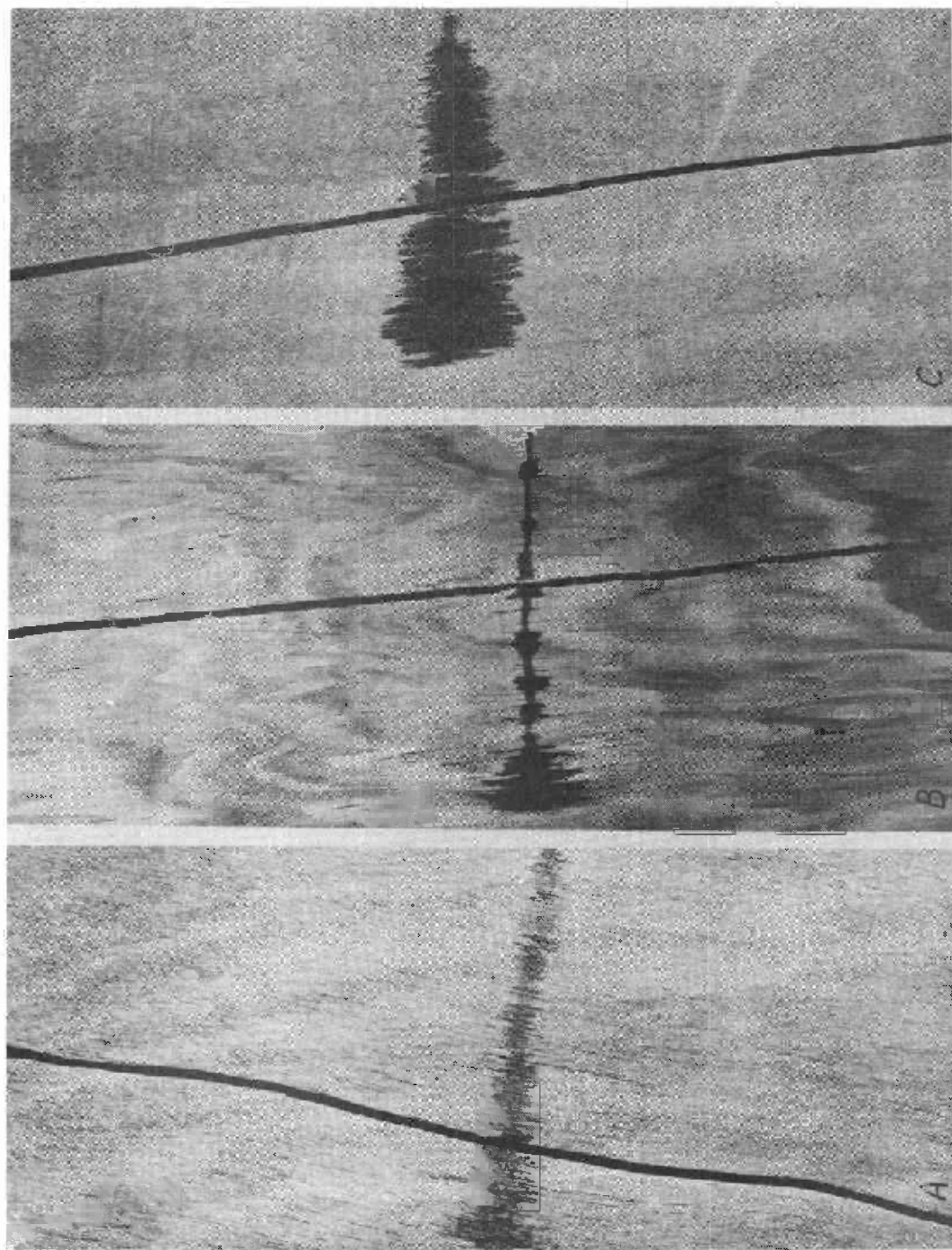

Figure 13.--Ink test for determining direction of grain on tangential surfaces also determined by splitting in all three samples and by orientation of pores in A and of resin ducts in B. A, Yellow birch; B, Douglas-fir; C, yellow poplar.

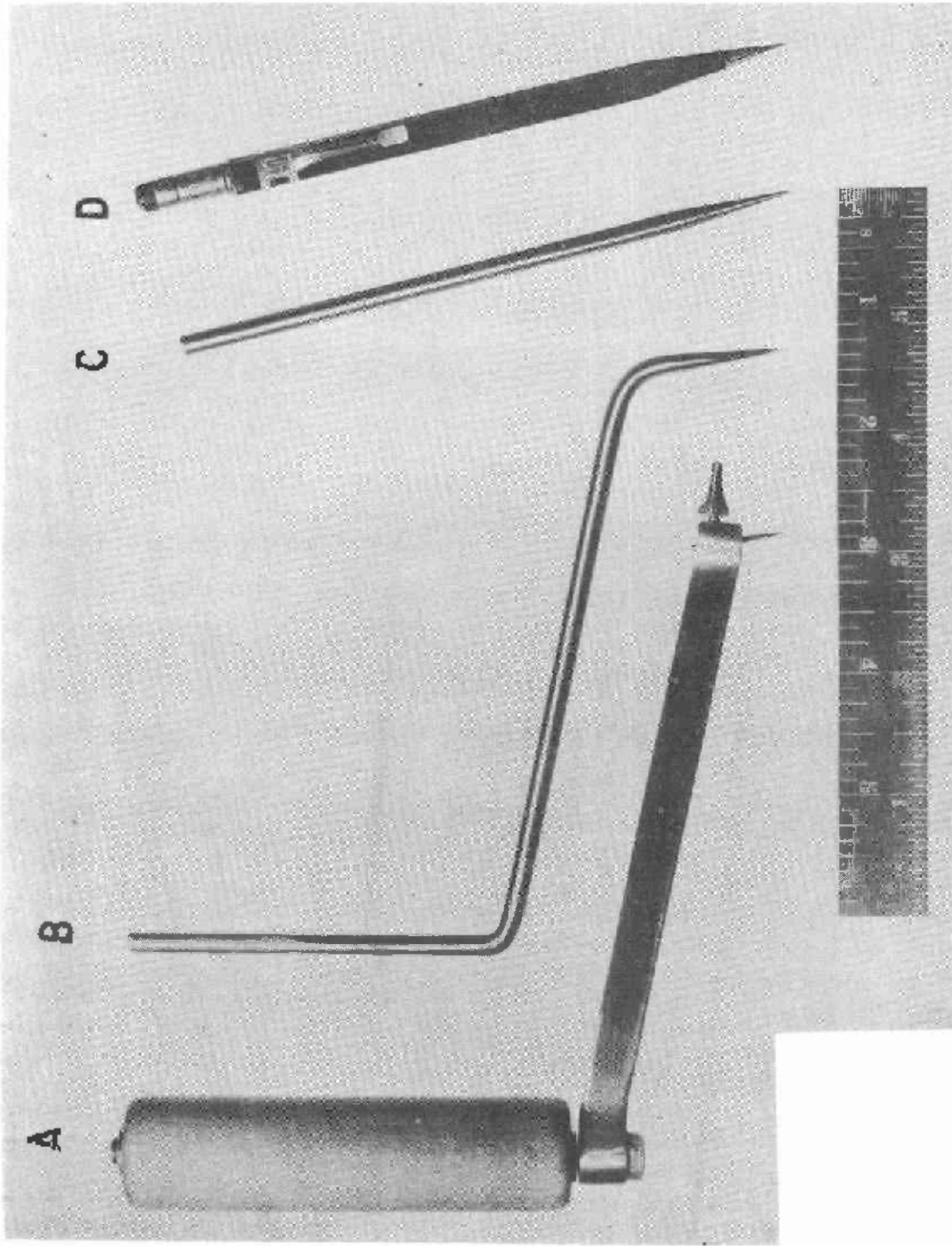
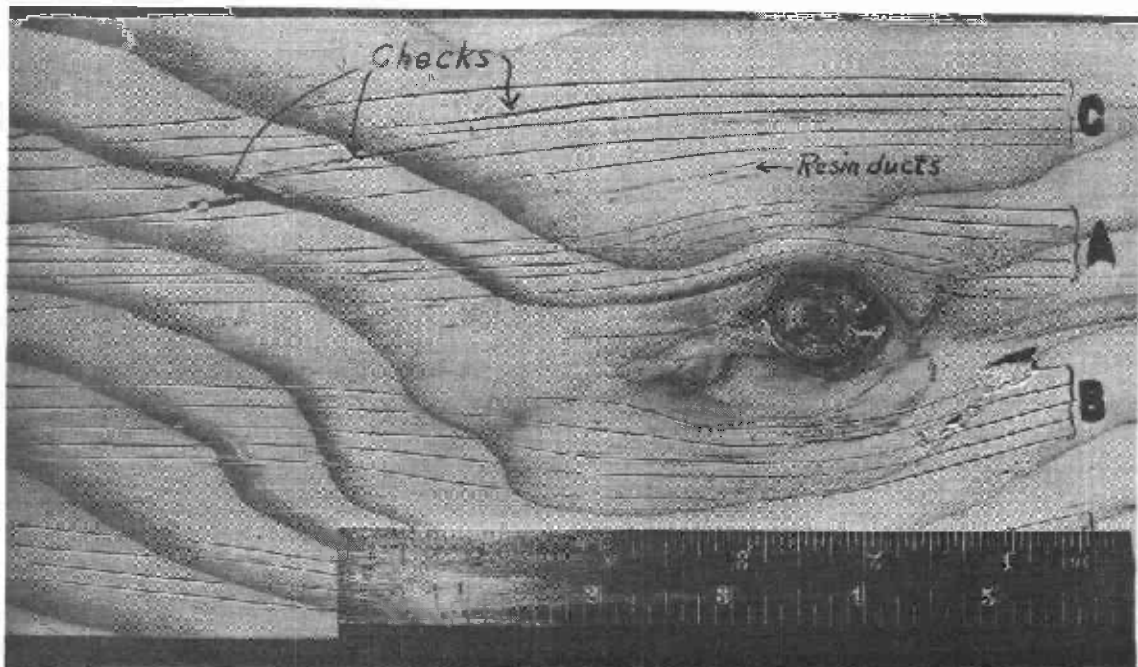
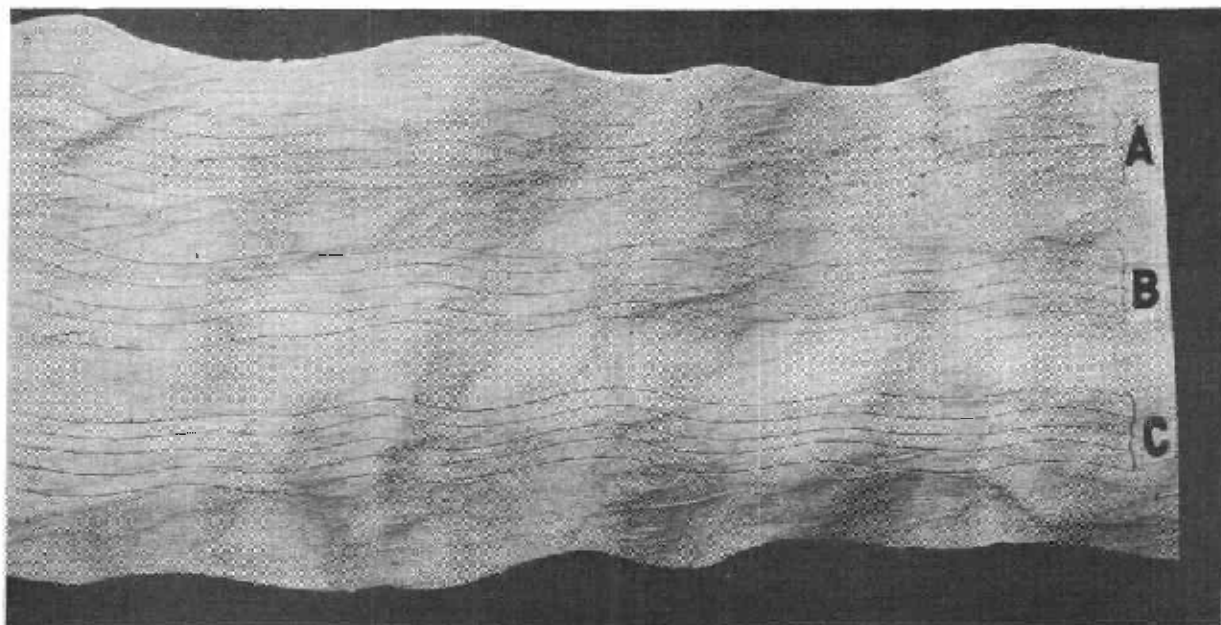

Figure 14.--Scribes for determining direction of the fibers on the surface of wood. A, Swivel-handled scribe with phonograph needle point; B, one-piece drill rod bent to shape and point slightly hardened; C, a straight piece of drill rod with point slightly hardened; D, mechanical pencil with phonograph needle point.



A



B

Figure 15.--Tangential surfaces of wood tested with scribes A, B, and C (fig. 14) to determine direction of grain. Note parallelism of scribe marks in same areas. A, Douglas-fir, showing relation of scribe marks to checks and resin ducts; B, wavy-grained birch veneer showing parallelism of scribe marks to split edges and to pores.

ZM 48843 F

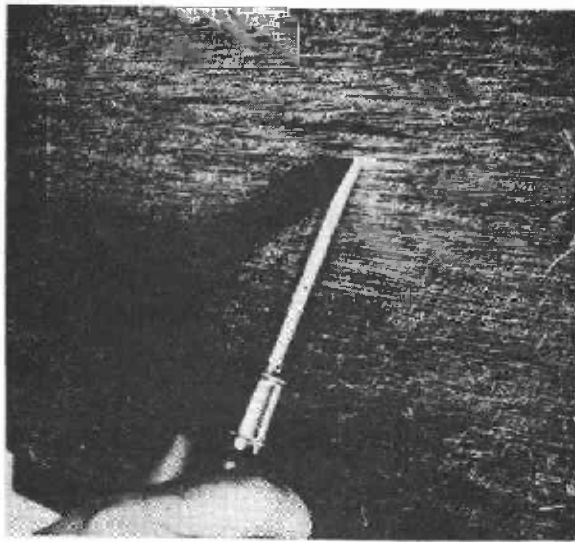
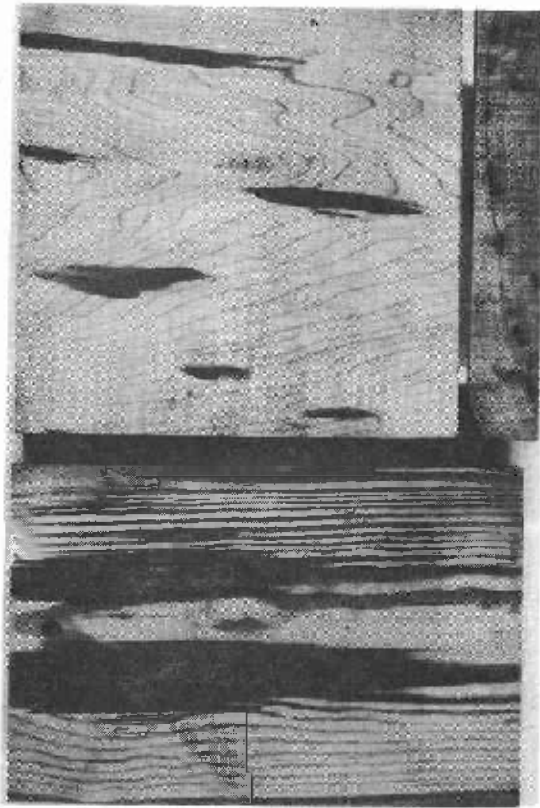

Figure 16.--Pick test for determining slope of  
Z M 48244 P grain in rough lumber.



A

B

Figure 17.--A, Pitch streak in yellow pine; B, mineral streaks in  
sugar maple showing general direction of grain.

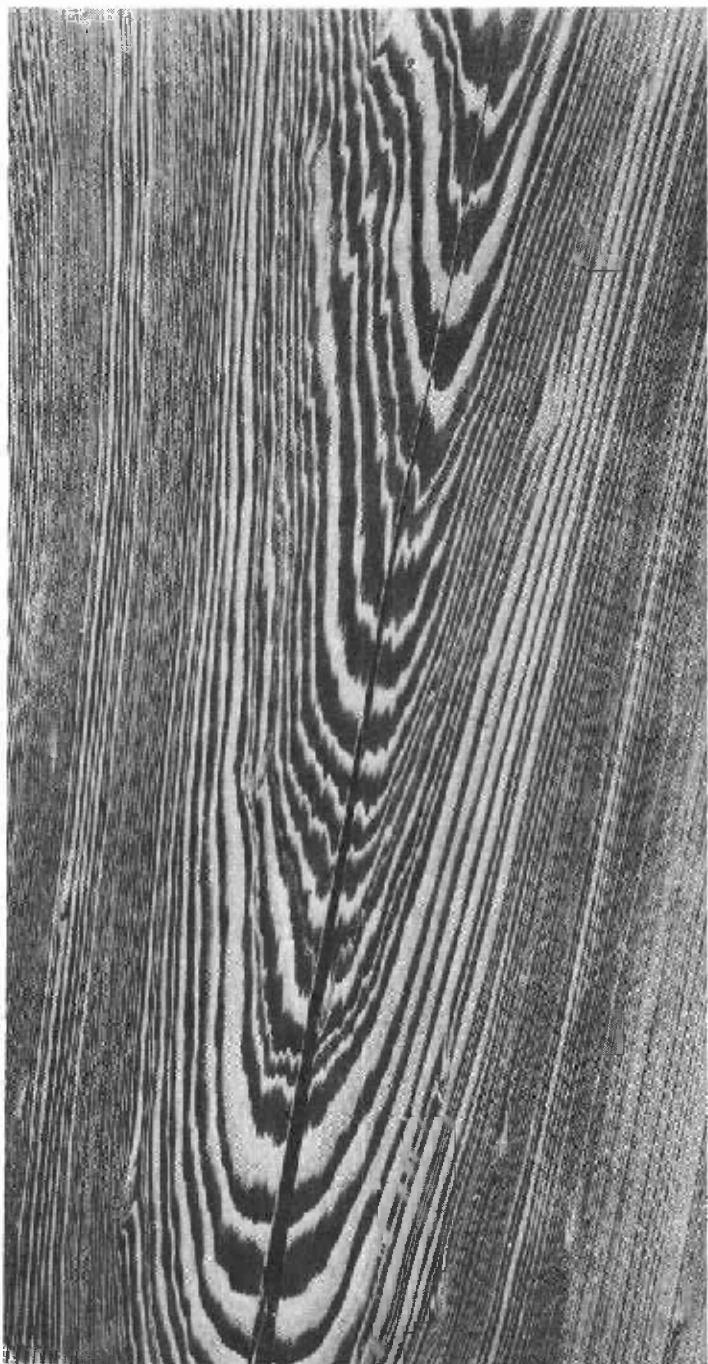

**Figure 18.**--Artificial spiral grain in baldcypress as indicated by alignment of apexes of annual rings on the tangential surface (when diagonal grain is present) with direction of fibers as shown by the radial split.

Z M 48845 F



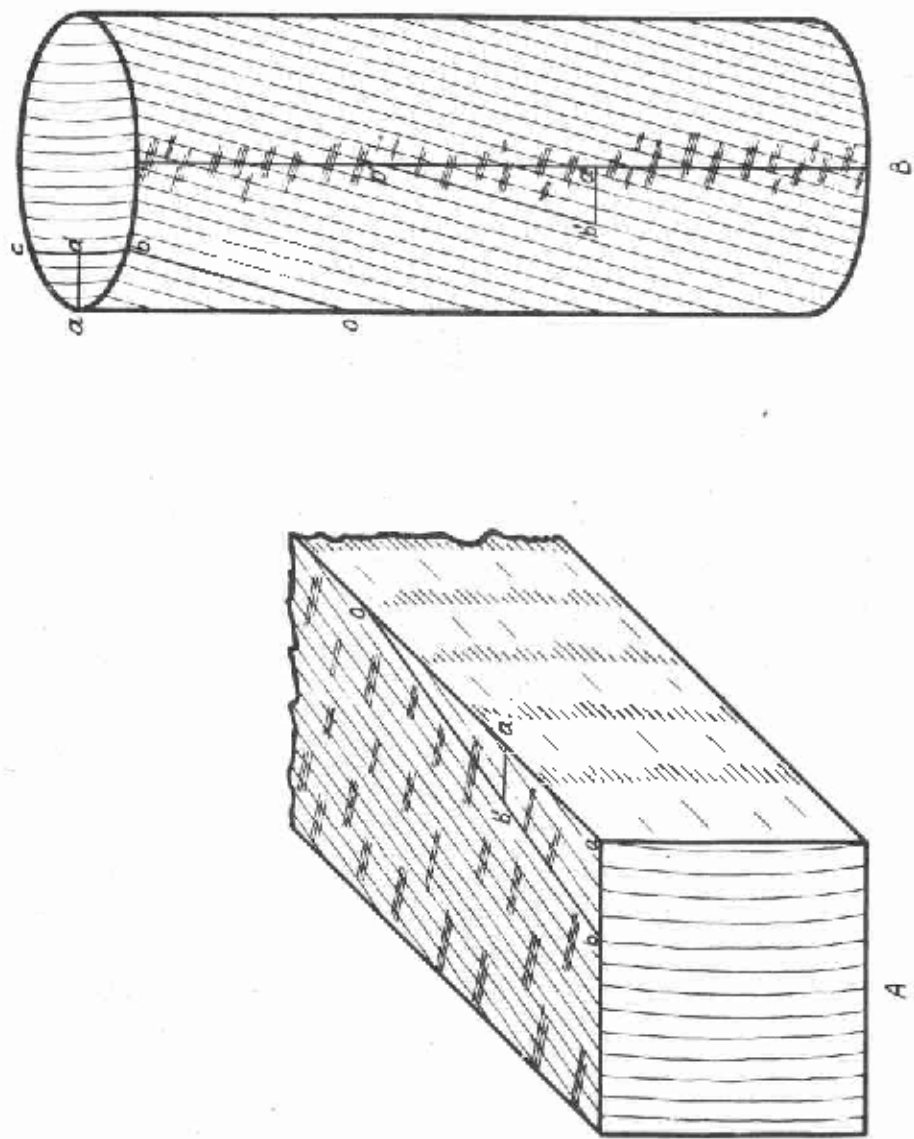

Figure 19.--Method of determining slope of diagonal grain in wood with a radial surface. A, Rectangular piece; B, cylinder.

2 of 48846 F

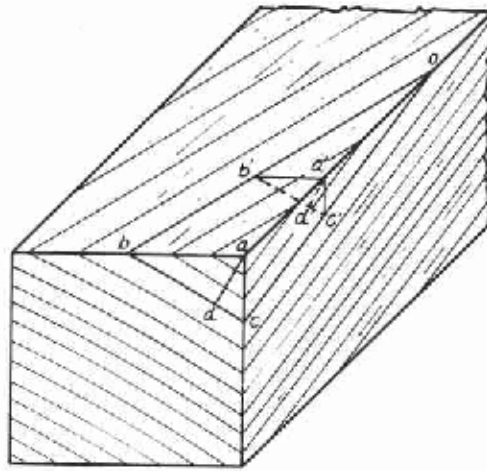

Figure 20.--Method of determining slope of diagonal grain in wood without a radial surface.

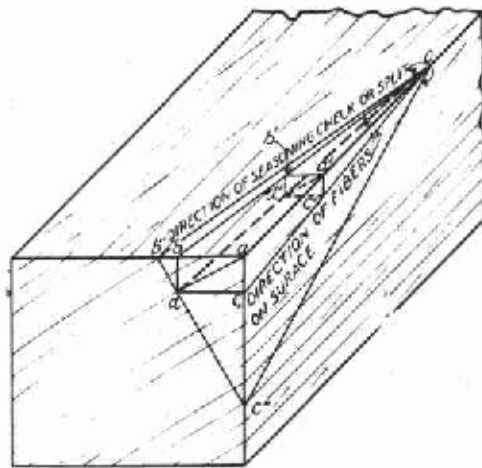

Figure 21.--Method of determining slope of spiral grain in wood without a tangential surface. The line  $d$  indicates the direction of the fibers in the interior.  
 2 M 48947 F

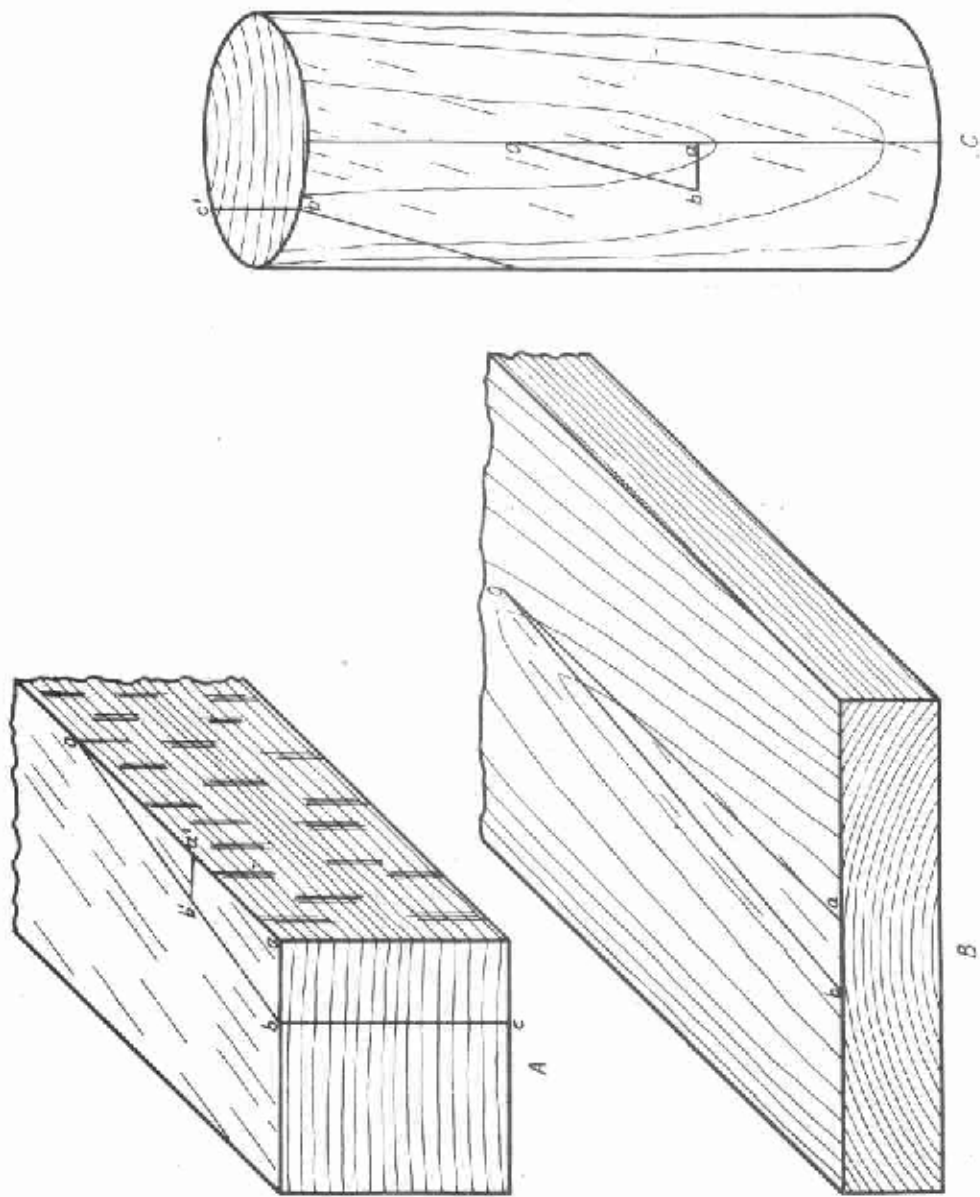

Figure 22.--Method of determining slope of spiral grain in wood with a tangential surface. A, Rectangular piece; B, board; C, cylinder.

Z M 4384B F

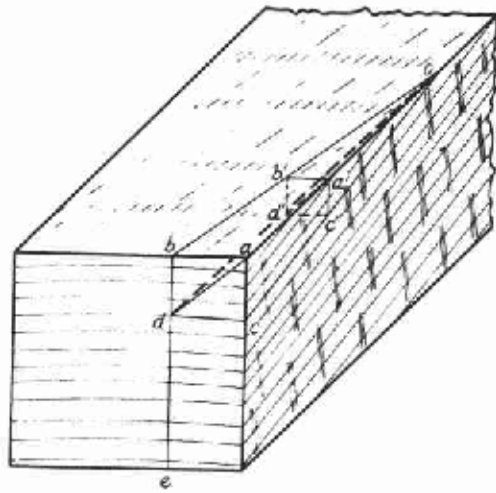

Figure 23.--Method of determining combined slope of diagonal and spiral grain in wood with radial and tangential surfaces. The line do indicates the combined slope, or true direction, of the fibers in the interior.

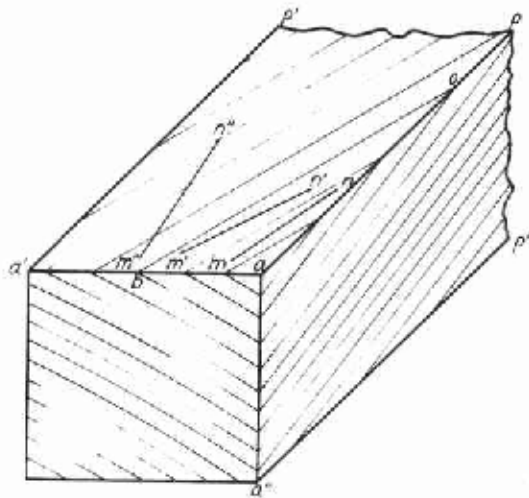

Figure 24.--Method of determining toward which longitudinal corner the grain slopes in wood with diagonal and spiral grain without radial or tangential surface.

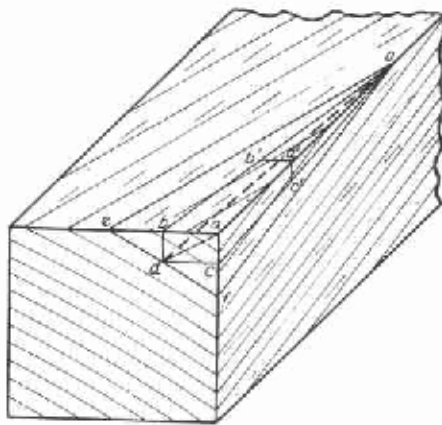

Figure 25.—Method of determining combined slope of diagonal and spiral grain in wood without radial and tangential surfaces on longitudinal corner farthest from or corner nearest to the center of the tree. The line do indicates the combined slope, or true direction, of the fibers in the interior.

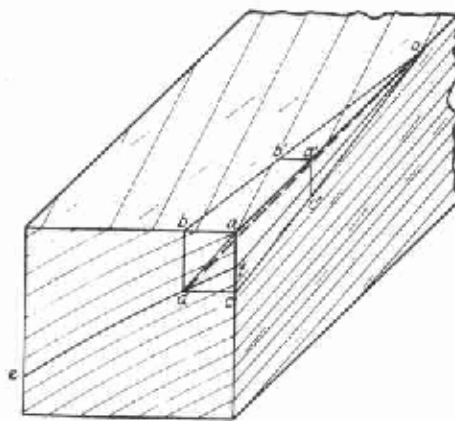

Figure 26.—Method of determining combined slope of diagonal and spiral grain in wood without radial and tangential surfaces on a longitudinal corner neither farthest from nor nearest to the center of the tree. The line do indicates the combined slope or true direction, of the fibers in the interior.

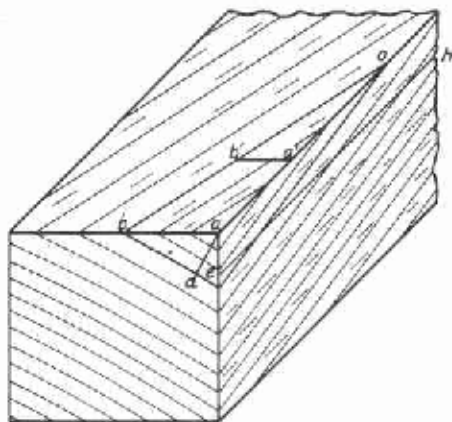

Figure 27.—Method of determining combined slope of diagonal and spiral grain in wood without radial and tangential surfaces if the fibers are parallel to one surface, a special case. The line *bo* indicates the combined slope, or true direction, of the fibers.

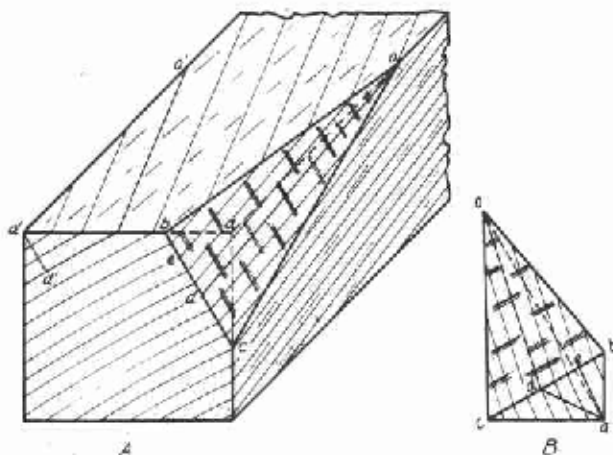

Figure 28.—Method of determining combined slope of diagonal and spiral grain in wood without radial and tangential surfaces by splitting off one corner radially when slope of spiral grain is large in comparison with diagonal grain. The line *bo* indicates the combined slope, or true direction of the fibers.



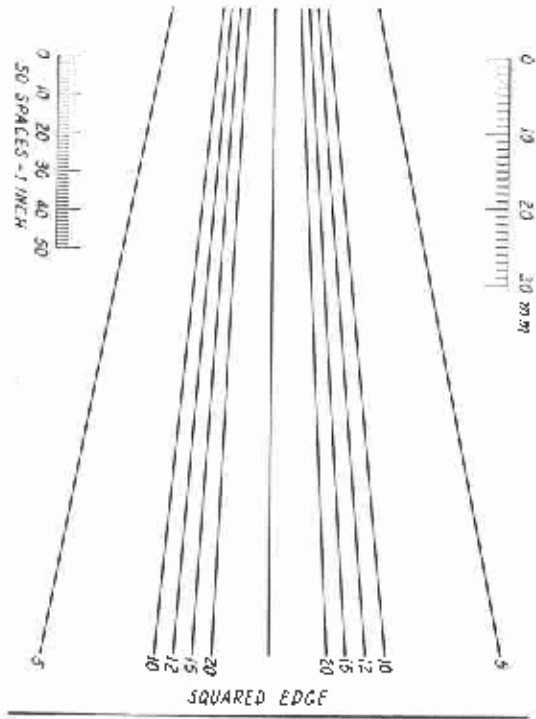

Figure 31.--Transparent plate with lines of various slopes to the right and left with respect to a middle line which is perpendicular to one edge.

Z H 48855 F





Figure 32.--Rotary-cut birch veneer showing broad annual ring pattern across the grain and knife marks at right angles to the edges; also spiral grain as indicated by split which is not parallel with alignment of apexes of annual rings due to diagonal grain.

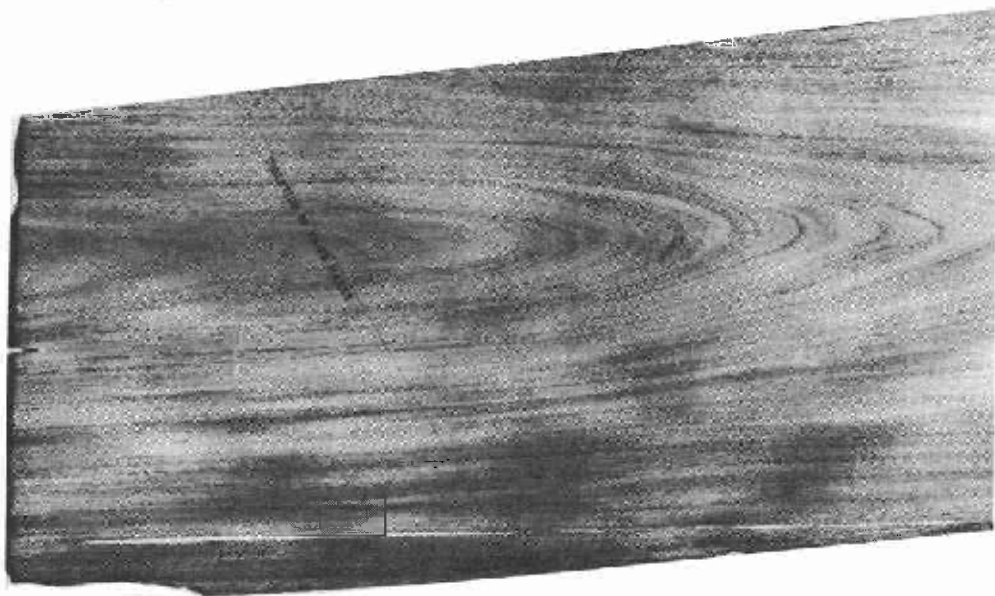

Z M 48854 P

Figure 33.--Flat-sliced mahogany veneer showing typical annual ring pattern and knife marks inclined to the grain.

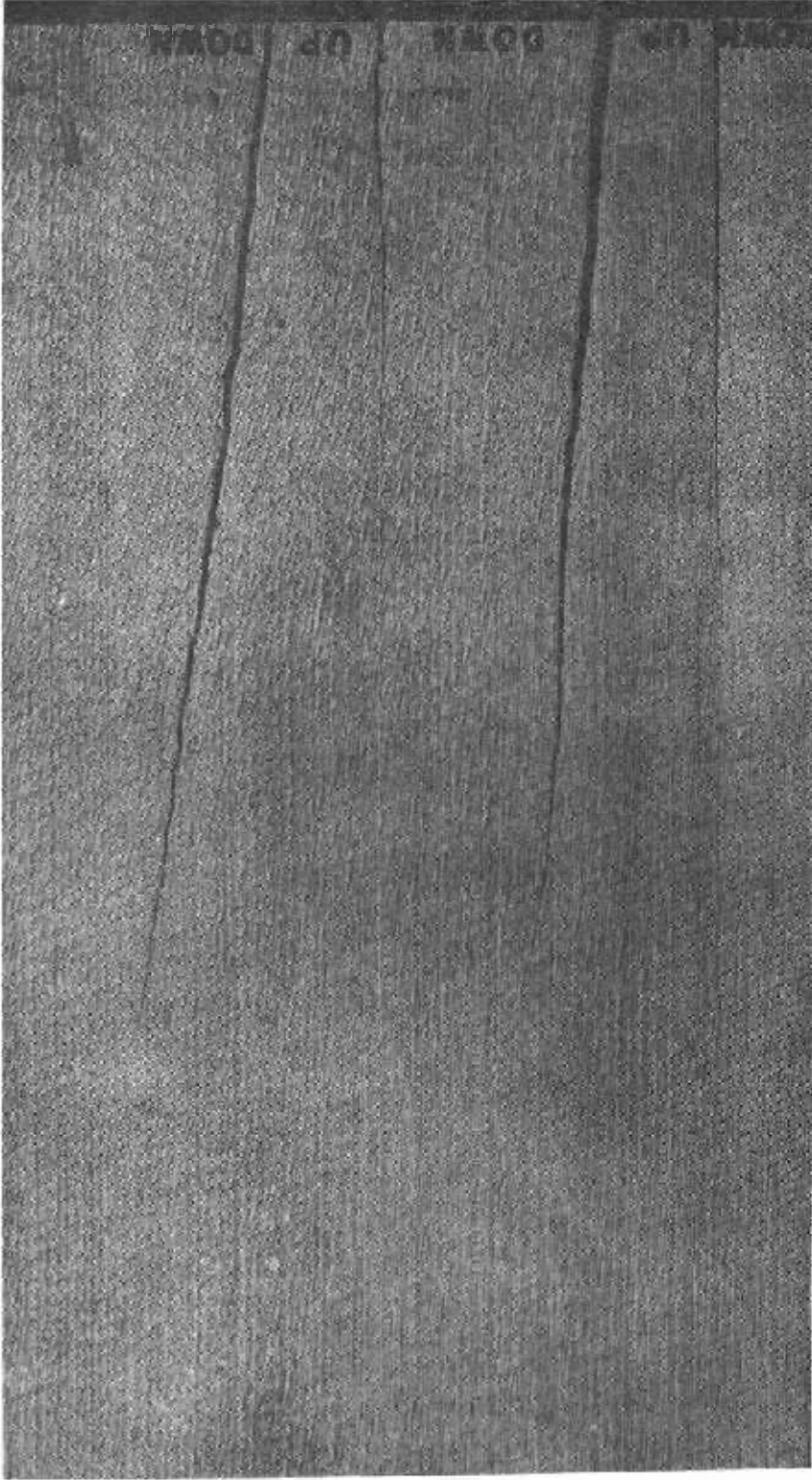

Figure 34.--Difference in direction of tear of Douglas-fir veneer sliced nearly radially, depending on whether right or left hand is pulled up or down.

Z M 48855 F

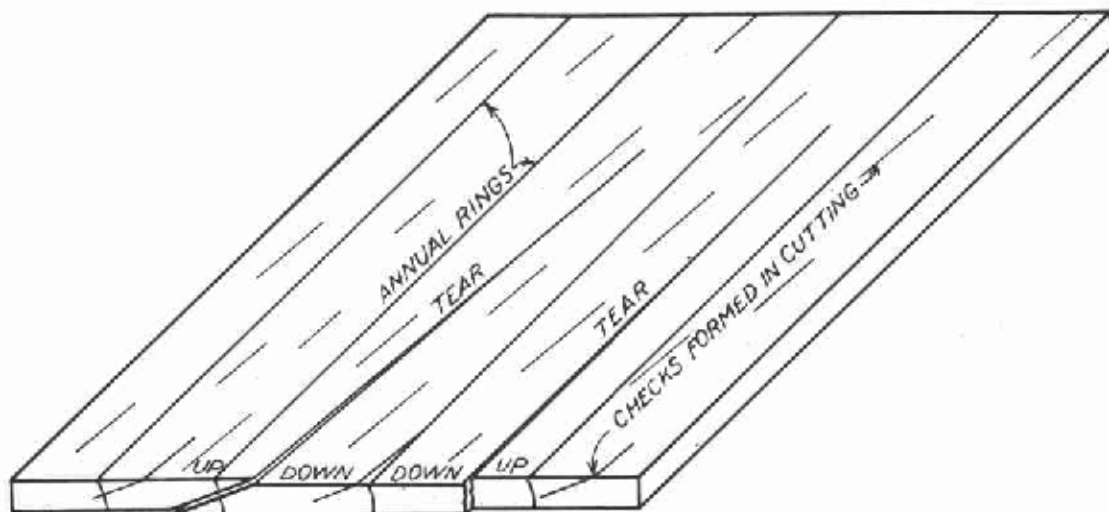

Figure 35.--View of back, or open, side of a piece of veneer sliced nearly radially showing direction of checks due to cutting and their influence on direction of tear.

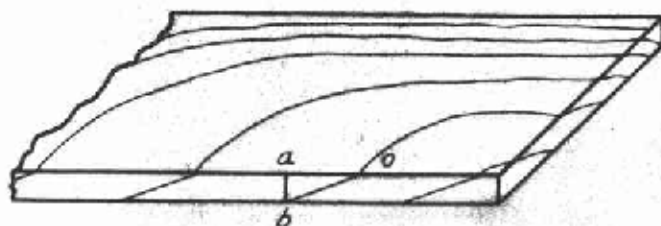

Figure 36.--Method of measuring slope of grain through a sheet of veneer. The line ba represents the direction of the grain through the sheet as indicated by annual rings, pores, fibers, or fracture. The line ab represents the thickness of the veneer.