



# 4-H DRESSAGE MANUAL

## Introduction to 4-H Dressage

**W**hat is dressage? Somehow this word has developed an aura of mystery among youth and adults in the 4-H Horse Program. In simple terms, dressage is not unlike the basic training given to armed-forces recruits. Dressage is a French word that means “training” or “schooling.” All the aids (hands, seat or weight, and legs) are used in varying degrees to guide the horse through a set of maneuvers that are natural to the horse. Dressage teaches a horse to be obedient, willing, supple, and highly responsive to the wishes of the rider.

Not every horse schooled in dressage will become a Grand Prix horse destined for Olympic competition, but every horse, regardless of its size, disposition, or ultimate use, can benefit from dressage. Keep in mind the first horse you worked with in the 4-H program. You started training that horse with some basics you learned from your 4-H leader or your parents. As you and your horse learned from each other, you advanced in your skills and abilities one step at a time. Dressage competition is a similar process. Dressage is a combination of equitation and horsemanship; knowing how to produce each movement until you and your horse move as one.

The object of dressage is the harmonious development of the physique and ability of the horse. A dressage rider becomes precisely tuned to the movements of the horse’s body. Through progressive exercises of both horse and rider, the horse becomes calm, supple, obedient, and highly skilled, achieving a perfect understanding with its rider.



## Contents

<b>Introduction to 4-H Dressage</b> .....	<b>1</b>
Why ride dressage?.....	2
<b>Illustrated Glossary</b> .....	<b>3</b>
<b>Levels of Competition</b> .....	<b>18</b>
U.S. levels.....	18
International levels .....	19
<b>How to Ride Dressage</b> .....	<b>20</b>
Where to get dressage training .....	20
<b>General Rules</b> .....	<b>21</b>
Dress .....	21
Saddlery and equipment .....	21
Dressage competitions.....	22
Arenas.....	22
<b>Riding Your Training Level Test</b> .....	<b>23</b>
<b>How the Test Is Judged</b> .....	<b>25</b>
Causes for elimination .....	25
More on how the test is judged.....	25
Collective marks .....	26
<b>Resources</b> .....	<b>27</b>

Revised by Joyce T. Stride, Oregon Dressage Society 4-H representative; Donna Longacre, dressage judge; Tammy Bowers, Snohomish County dressage coordinator, Washington; Roberta Lundeberg, program coordinator, Oregon State University; and Pat Pehling, Washington State 4-H Equine Advisory Committee chair.

Originally written (1990) by Joyce T. Stride, Oregon Dressage Society 4-H representative, and Bradford J. Jeffreys, former Extension specialist, 4-H youth development, Oregon State University; S. Marina Schrader, Oregon 4-H leader and horse judge; Barbara Tuohino Funk, Oregon Dressage Society 4-H representative; and Esther Cate, Oregon 4-H horse show judge. Reviewed by Linda Coates-Markle, former senior instructor in animal science and former director, Horse Center, Oregon State University.

## Why ride dressage?

Through your participation in a 4-H horse club, you'll learn to enjoy your horse more than you ever have. Your project horse will become a better performer and more enjoyable to ride. At the beginning level (Training Level), the movements are not difficult, but doing them correctly enables you to advance to the upper levels of dressage competition. By doing well at the training level, the horse will be prepared mentally and physically for each advancement in the dressage levels.

Dressage keeps you interested in riding because there is always more to learn. You'll find out why the horse moves the way it does and how you can improve its response. As a rider of dressage, you'll discover how to communicate movements to your horse with patience and tact. Dressage will help you and your horse work together as a team.

After you have completed the beginning stages, you'll begin to see the overall picture and to determine where your horse's talents lie: advanced dressage, jumping, cross country, western riding, etc. You can apply dressage training to any style of riding. Your reward will be a keenly disciplined pleasure horse that is ready to pursue any type of competition.

This publication briefly introduces the concept of dressage, terminology, levels of competition, how to ride a test, how the test will be judged, and equipment and general rules used in competitions.

To properly begin dressage work, a thorough knowledge of the terms used in dressage tests is essential. On the following pages, you'll find illustrations and terms that your 4-H leader and dressage judge use to evaluate your progress and performance in the arena.

## Illustrated Glossary

Words in **bold** are included in the Glossary.

### Above the bit

An **evasion** characterized by the horse raising its head and stretching forward with its neck, so that the mouth and bit are above the rider's hands. The back **hollows** and stiffens and the hocks trail out behind.

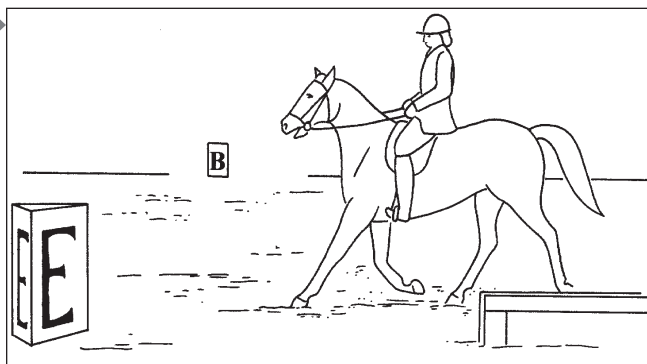

### Against the hand

Horse going up against the bit too strongly (but not above the bit).

### Aids

Signals the rider uses to convey instructions to the horse. There are two types:

1. Natural—The hands through the reins, the rider's legs, the rider's seat and balance, and the **voice**.
2. Artificial—Whips and spurs.

### Asking down

Giving soft little tugs on one rein by closing and opening the fingers or bending and straightening the wrist. The bit remains in contact with the hand throughout the motion. The result is the horse lowering its head and softening its jaw and neck muscles.

### Behind the bit, behind the aids, behind the leg

An evasion in which the horse retracts or shrinks back from the bit/contact, avoiding stepping forward into the contact. The head may or may not be **behind the vertical**.

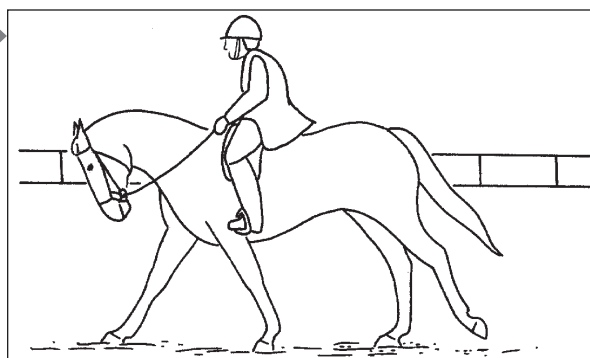

### Behind the vertical

The head position in which the horse's nostril falls behind the imaginary line dropped from the horse's eye (i.e., toward the chest). The horse may or may not be behind the bit.

### Bend

The laterally arced position in which the horse's body appears to form an even curve from poll to tail. Examples of faulty bend are bending only in the neck, only at the base of the neck, or bent toward the wrong direction.

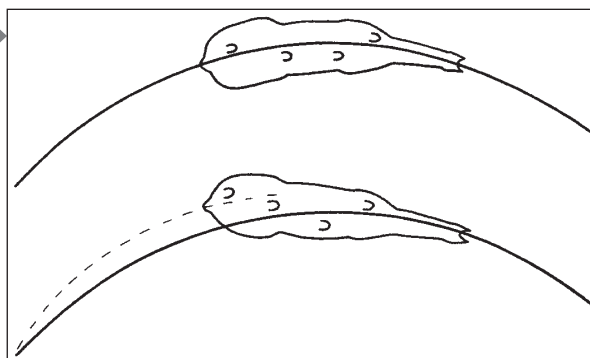

One horse is bent correctly. Both body and neck are curved and the hind feet are following the forefeet. The other horse has bent only its neck. Its body is straight and its hindquarters are falling out.

### Cadence

A clarity of rhythm in which movements are well marked, rhythmic, and harmonious.

### Canter

A pace of three beats—the footfalls are as follows (for the right lead): Left hind, left diagonal pair (simultaneously left fore and right hind), right fore, followed by a moment of suspension with four feet in the air before the next stride begins. The canter should always be light, cadenced, and regular. The general impression indicates quality. It originates in the acceptance of the bridle with a supple poll, the engagement of the hindquarters with active hock action, and the ability to maintain the same rhythm and natural balance, even after the transitions. The horse should always remain straight on straight lines, without the haunches falling in or out.

### Cavesson (or noseband)

An adjustable device made of leather used to keep the horse's mouth shut.

### Change of lead through the trot

A change of **canter** leads, in which the horse is brought back to the trot and, after two to three steps, is restarted into a canter with the other side leading.

### Change of rein

A change of direction; to go around the arena in the opposite direction or to change from one curve to another. The most common way is to change rein across the **diagonal**.

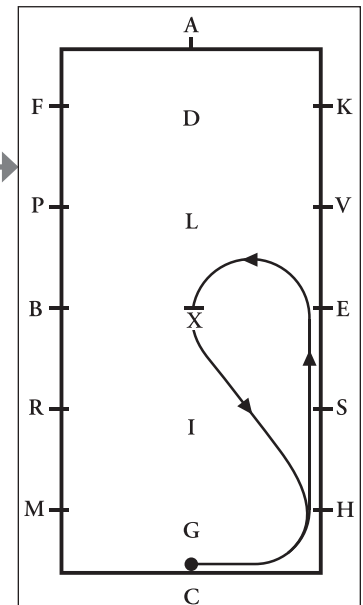
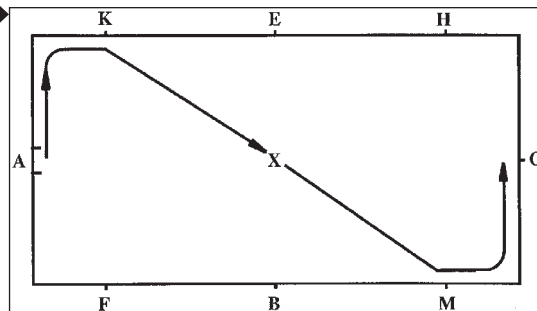

### Circle

A round figure, generally in the standard sizes of 20 meters, 15 meters, 10 meters, and 6 meters, with consistent bending of the horse to the inside of the circle from nose to tail. The circle touches the track at only four points, and each quarter circle is the same. (1 meter = 3.3 feet.)

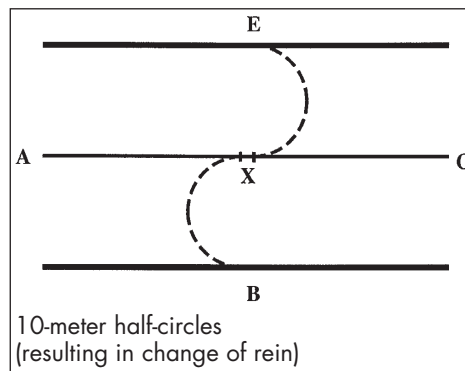
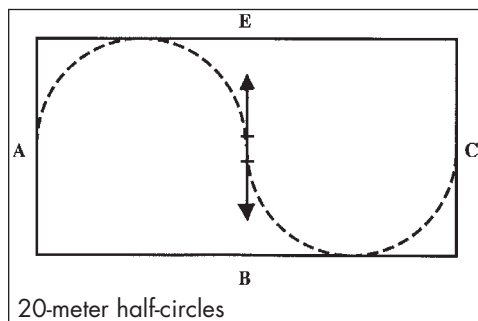
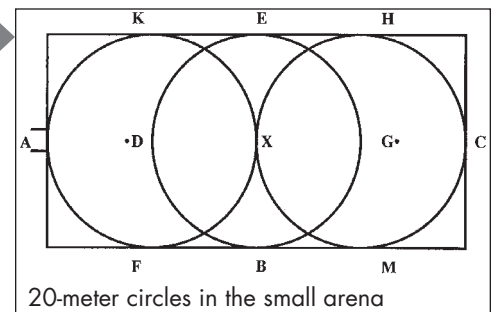

## Collection

State in which the horse is gathered together. It is a matter of degree closely related to the particular exercise and training level of the horse. Relative to working and medium paces, the strides are shorter (yet powerful), the outline appears shorter with the neck rising unrestrained out of lifted withers, and the engagement (support phase) is more marked. The face is slightly in front of the vertical, and the horse is on the bit.

## Collective remarks

Judging scores awarded after the test is completed for (1) regularity of gaits; (2) **impulsion**; (3) submission; and (4) the rider's position and seat, correctness, and effect of the aids. Collectives are given a coefficient that doubles the score for gaits, impulsion, and submission, and triples the score for rider's position.

## Contact

The horse's stretching forward onto the bit and accepting the rein pressure as a means of communication with the rider's hands.

## Crookedness

The crooked horse's hind feet are not tracking in the prints of the front feet.

## Diagonal

1. Of the horse, a diagonal pair of legs.
2. Of the school or arena, corner to corner (K to M or F to H, crossing the centerline at X) (see diagram on page 4).
3. The rising phase of the rising trot that corresponds to the shoulder of the horse moving forward; can be the right or the left diagonal.

## Disunited

A wrong sequence of footfalls at the canter; the front legs are leading correctly and the hind legs are on the wrong lead, or vice versa. Sometimes associated with the term "cross-firing."

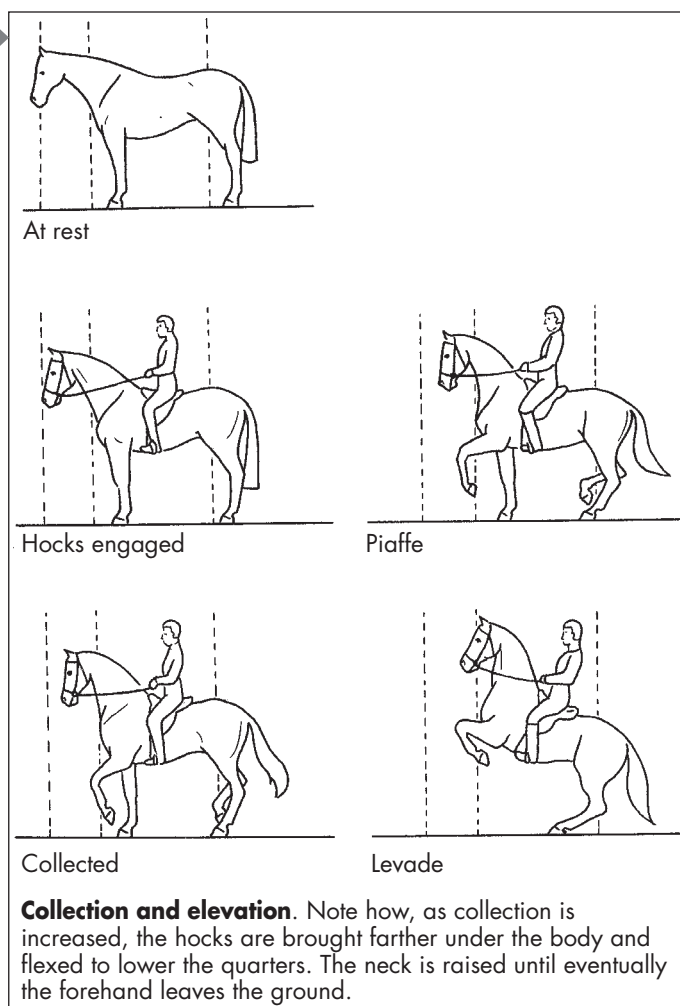

**Collection and elevation.** Note how, as collection is increased, the hocks are brought farther under the body and flexed to lower the quarters. The neck is raised until eventually the forehead leaves the ground.

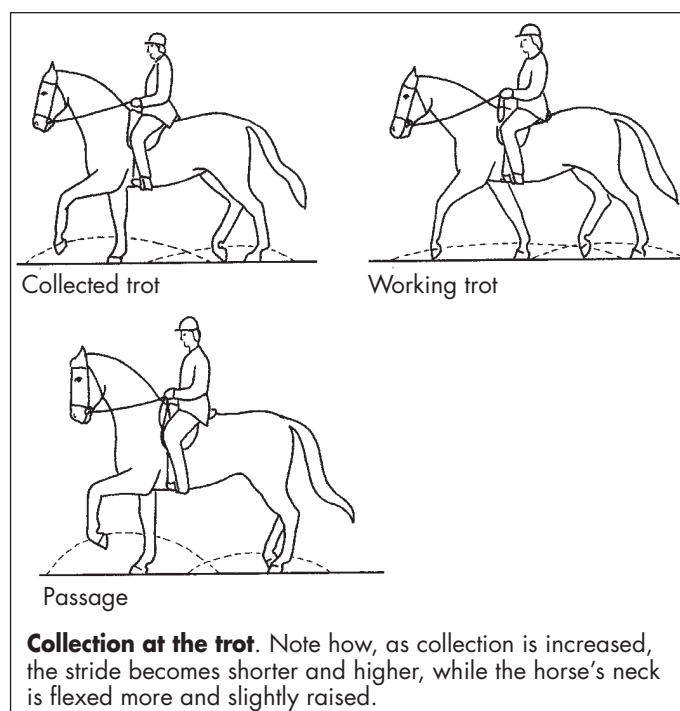

**Collection at the trot.** Note how, as collection is increased, the stride becomes shorter and higher, while the horse's neck is flexed more and slightly raised.

## Dressage arena

A rectangular area measuring 20 x 60 meters (standard) or 20 x 40 meters (small). Training level tests are often ridden in the small arena. The arena is enclosed by a low fence, and specific locations are marked by a standard system of letters placed around the outside on markers. The judge sits at C and the rider enters through a removable portion at A.

If there is more than one judge, they are placed according to USEF rules.

## Dressage test

A standard score sheet of specific movements, directions, and transitions, upon which the judge's comments are recorded to arrive at a score for judging the competence of a horse and rider at a specific skill level.

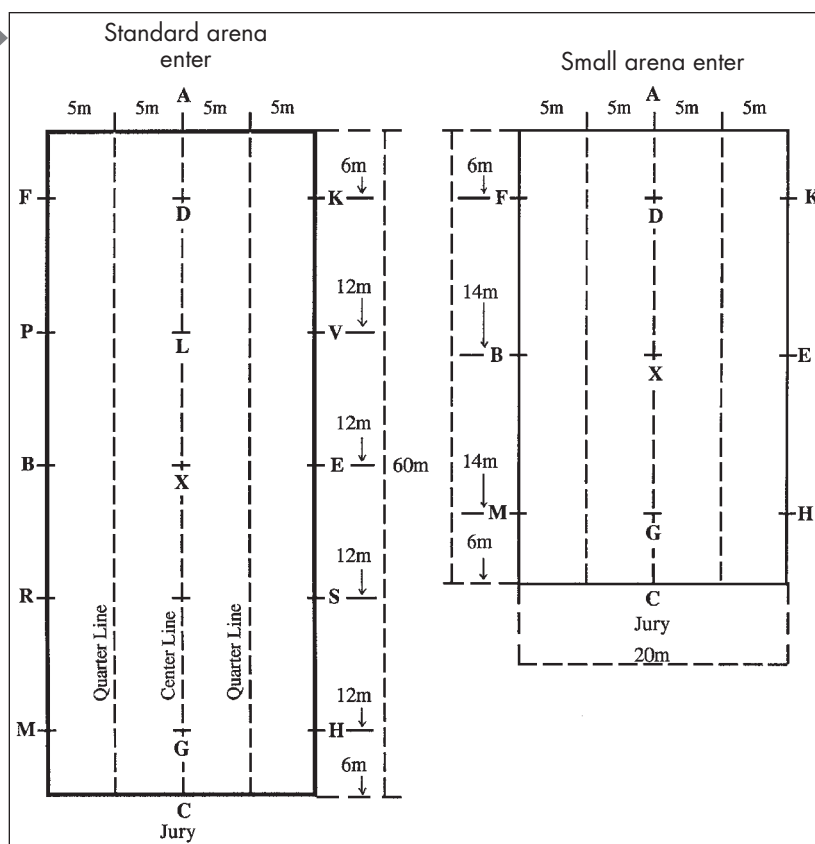

## Dropped noseband

A noseband that buckles beneath the bit. Used only with a snaffle bridle, it helps prevent a horse from opening its mouth or crossing its jaws to evade the action of the bit.

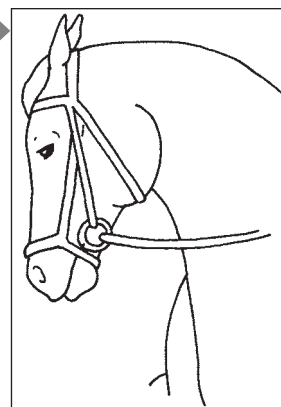

## Engagement/to engage the haunches

To bring each hind leg well forward under the body before placing it on the ground and pushing forward. It requires the horse to track up and bend the three joints in its hind leg (lowering the croup).

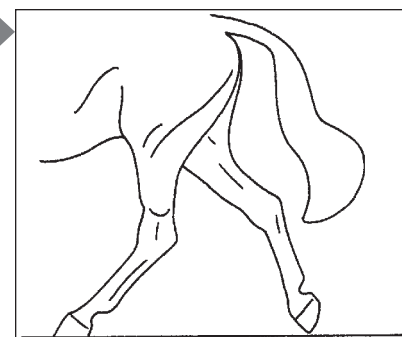

## Error of the course

When the rider wrongfully executes the direction of a movement in a test, i.e., takes the wrong turn or omits a movement. A bell or whistle sounds, and the judge shows the rider, if necessary, the point at which the rider must resume the test and the next movement executed. The rider then continues on his/her own. However, it is up to the judge to decide whether to sound the bell or not. Every error is penalized: first time—2 points; second time—4 points; third time—results in elimination; rider may continue the performance to the end, the marks being awarded not to count due to elimination.



## Error of the test

When a rider wrongly executes a movement, such as rising trot instead of sitting trot, not taking the reins in one hand during the salute, or leaving the arena after the test is completed in another way than prescribed in the test (such as trotting out after completion of the test). If the judge has not noted the error, the rider has the benefit of the doubt. The rider is penalized as for an “error of the course.”

## Evasion

Willful maneuver by the horse at the walk, trot, or canter with or without a change of rhythm, tempo, or regularity in order to escape the rider’s aids.

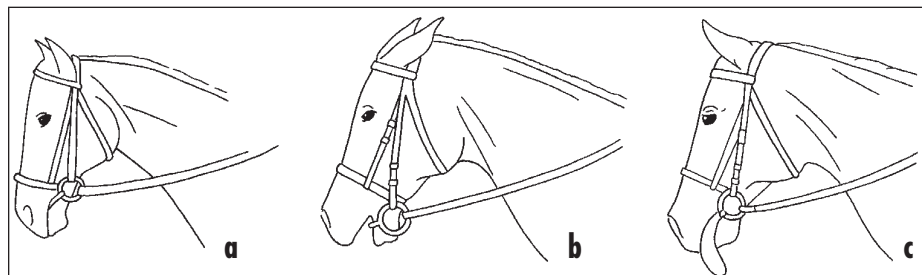

**Evasion. (a) Broken neck.** Flexion too far behind the poll. Though so-called, it has probably little to do with dislocated vertebrae, but is a wrongly developed muscular formation caused by forcing the horse into flexion too early in its training. **(b) Mouth open.** Shows lack of relaxation and non-acceptance of the bit. Ears laid back, unwillingness or resistance. In this case, the bit is too low in the horse’s mouth, causing discomfort. **(c) Tongue protruding.** The tongue probably has got over the bit—a bad fault and difficult to cure; generally caused by rough hands in the early stages. If the tongue protrudes for short periods, without being over the bit, the fault is not so serious. The trouble may be due to insufficient room for the tongue under the bit.

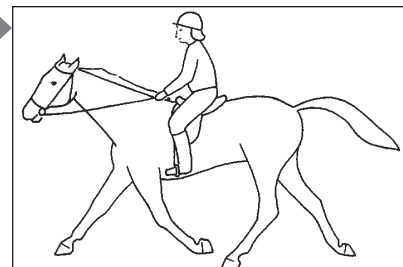

**Evasion: Running.** The horse pokes its nose, kicks the soles of the hind feet out backward, and hurries; all the weight is on the forehead. Produced in a mistaken attempt to lengthen the stride at the trot.

## Extension

Stretching and lengthening of the topline and stride and, in trot and canter, an increased phase of suspension. The horse covers as much ground as possible with each stride, but maintains the same tempo.

## Figure eight

A movement which consists of two circles of equal size in different directions as prescribed in the test, joined at the center of the “eight.” The rider should make the horse straight astride before changing direction at the center of the figure.

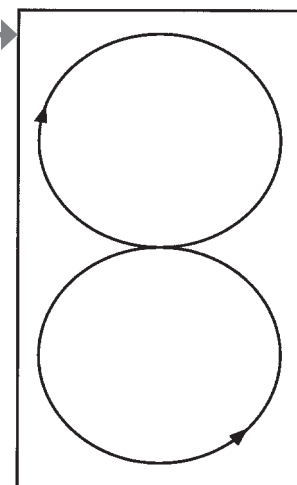

## First Level

A competitive designation to determine that the correct foundation is being laid for the successful training of the riding horse. The horse moves forward in a relaxed manner and with rhythm, its spine always parallel to the track of the prescribed movement. It accepts the bit and obeys simple aids of the rider.

First Level tests require not only the obedience and relaxation shown at the Training Level, but also a “soft response” to the aids. Examples of this response are softening of the jaw, some **flexion** at the poll, **lateral** bending, and quiet **transitions**. Current test requirements are **serpentine** at the trot, lengthened strides at the trot, 10-meter **circles** at the trot, lengthened strides at the canter, transitions that are less progressive (such as trot to halt with no walk steps), and change of leg at the canter through the trot.

### Flash noseband

An extra strap attached to a regular cavesson and fastened below the bit. This noseband keeps the bit stable in the horse's mouth by not allowing it to open its mouth or cross its jaw to evade the bit.

### Flexibility

The ability to bend laterally (from side to side) or longitudinally (front to back).

### Flexion

1. The bending of the horse's joints, specifically the poll and the jaw, while yielding to the influence of the leg and the hand by flexing at the poll and relaxing the jaw.
2. The **lateral** bending of the horse's spine.

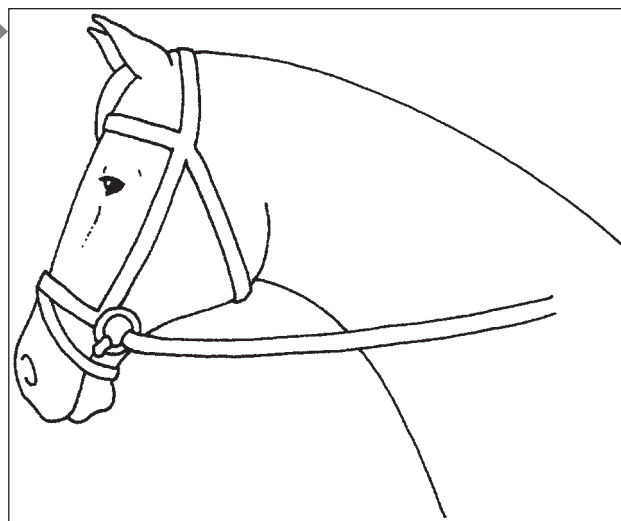

### Forging

Clicking the hind shoe against the front—a fault indicating fatigue, lack of muscle, sloppy or unbalanced riding, poor footing or shoeing, or conformation fault.

### Frame (outline)

The longer or shorter outline of the horse dictated by the relative degree of **extension** or collection.

### Freedom of movement

The extent to which a horse can reach forward with its hip joints and shoulders by virtue of a lively **impulsion** and the suppleness of its joints, showing freedom from resistance.

### Free walk

A pace of relaxation in which the horse is allowed complete freedom to lower and stretch out its head and neck without interference from rein; however, a light contact should be maintained.

*Free walk on a long rein.* The rider maintains light contact with the horse actively seeking the bit.

### Gait

A regular repeating sequence of footfalls. The horse has three gaits that form the basis of dressage: the **walk**, the **trot**, and the **canter**.

### Go large

To come off the circle and proceed around the arena on the rail.

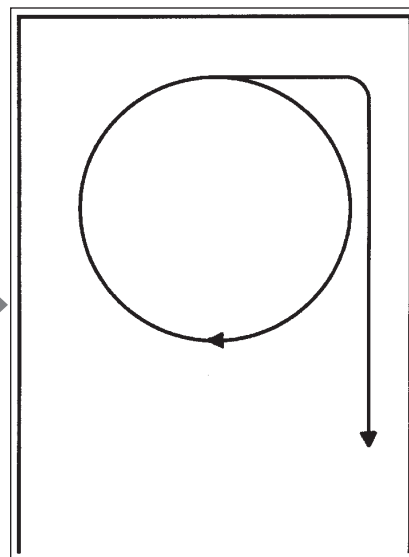



## Half-halt

A hardly visible, almost simultaneous, coordinated action of the seat, legs, and hands of the rider, with the object of increasing the attention and balance of the horse before the execution of a new movement, transitions to a lower or higher pace, or to rebalance. In shifting more weight to the hindquarters, the engagement of the hindquarters is increased and results in a lightness of the forehand and the horse's balance as a whole. To perform a half-halt:

1. Sit in a correct upright position.
2. Close the lower legs into a restraining but giving hand.
3. Lighten the seat.
4. Close the legs again and give slightly with the hands as the horse responds.
5. Apply the aids for the next movement required, or stay in the current pace.

## Halt

The horse should stand attentive, motionless, and straight, with its weight evenly distributed over all four legs, which are in pairs abreast (a square halt). The neck should be raised, the poll high, and the head slightly in front of the vertical. While remaining on the bit with a light and soft contact with the rider's hand, the horse may quietly

chew the bit and should be ready to move off at the slightest indication of the rider. A square halt is achieved by the **engagement** of the hindquarters by an increasing action of the seat and legs of the rider, driving the horse toward a more and more restraining but giving hand, causing an almost instantaneous but not abrupt halt at the point designated in the test.

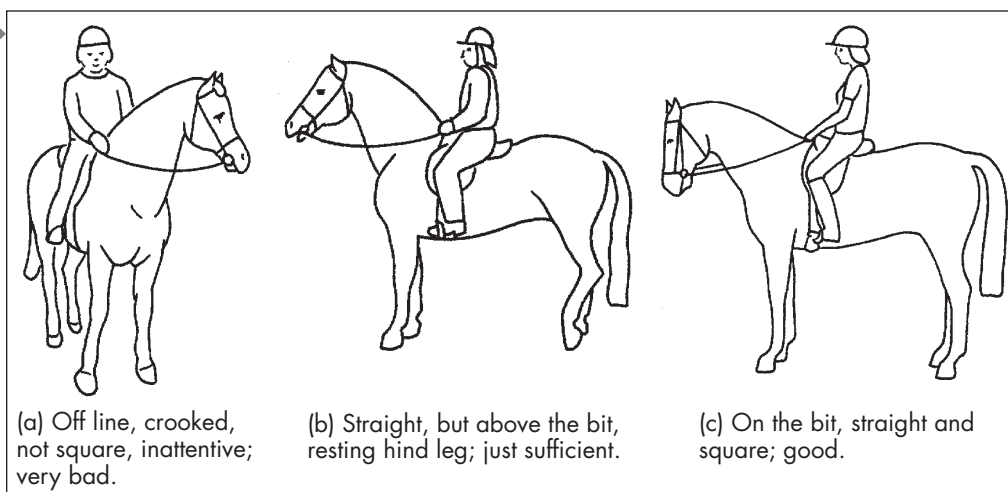

## Hollow

The raising of the horse's head and neck, resulting in a dropped or hollow back.

## Impulsion

Thrust: the elastic springing of the horse off the ground, beginning in the joints of the haunches flowing into a swinging back and ending in a soft mouth. Impulsion causes very energetic gaits. In order to show impulsion, the horse must be willing to go forward and must travel straight.

## Inside

The side toward which a horse is bending.

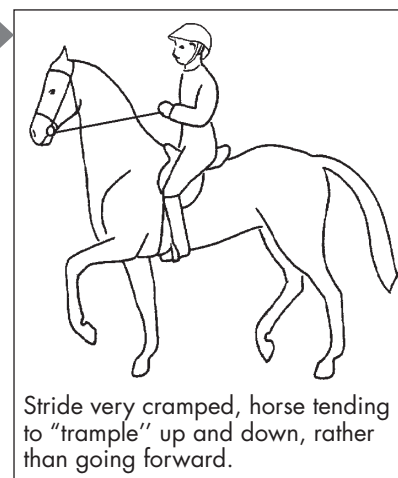
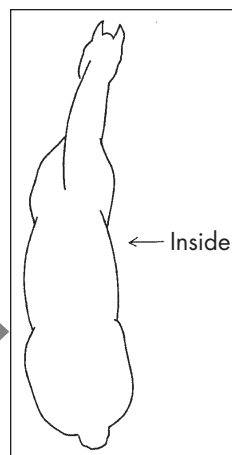

**Lateral**

1. To the side, as in flexion, bend, suppleness, or direction of the movement.
2. Impurity in walk (ambling or pacing) or canter; rarely trot.

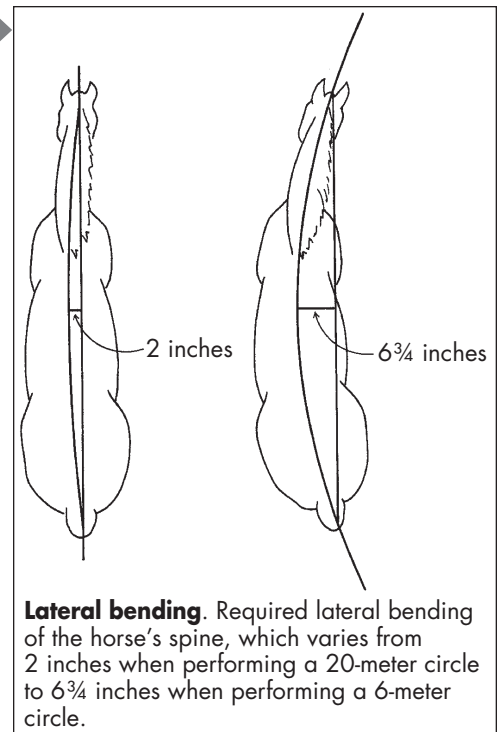
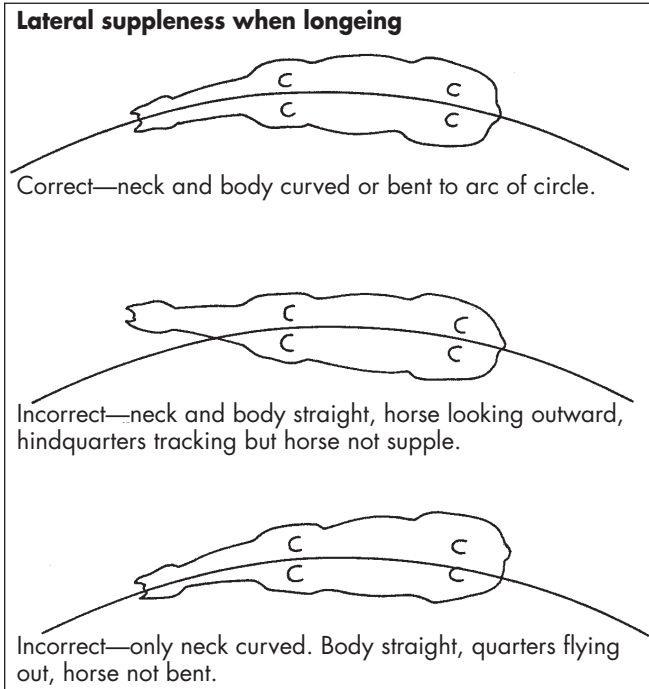

**Lateral movements**

Any work on two tracks, such as **leg-yielding**, **shoulder-in**, **travers**, **renvers**, and half-pass. Used to supple the horse and engage the hindquarters to aid collection.

**Leg-yield**

A lateral movement in which the horse moves forward and sideways, but is slightly bent away from the direction of movement. **Collection** is not required for leg-yielding.

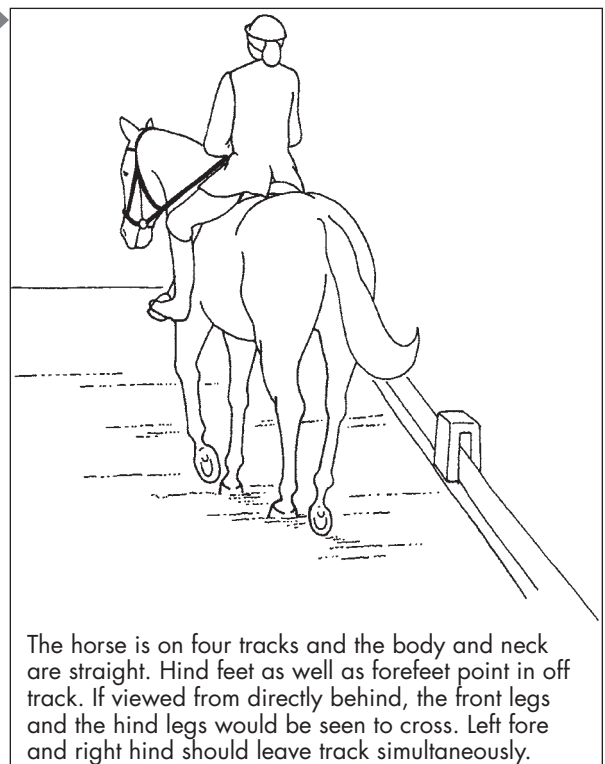
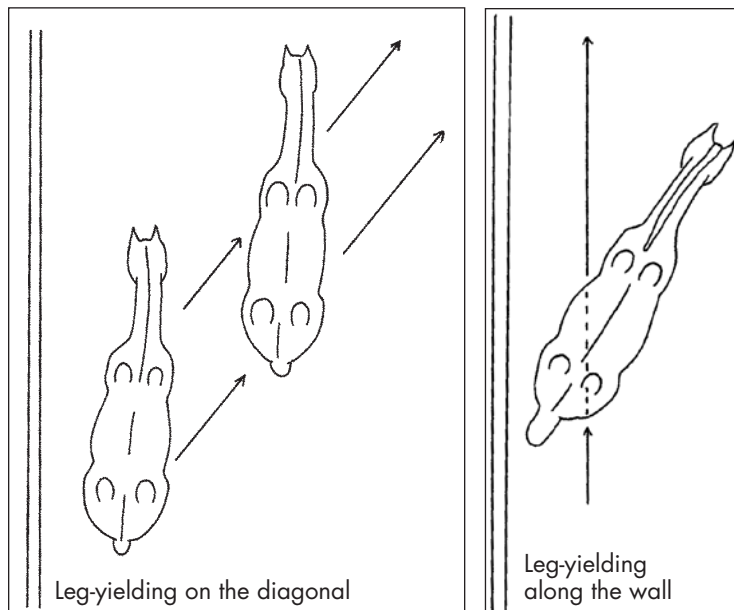

## Leg-yield (continued)

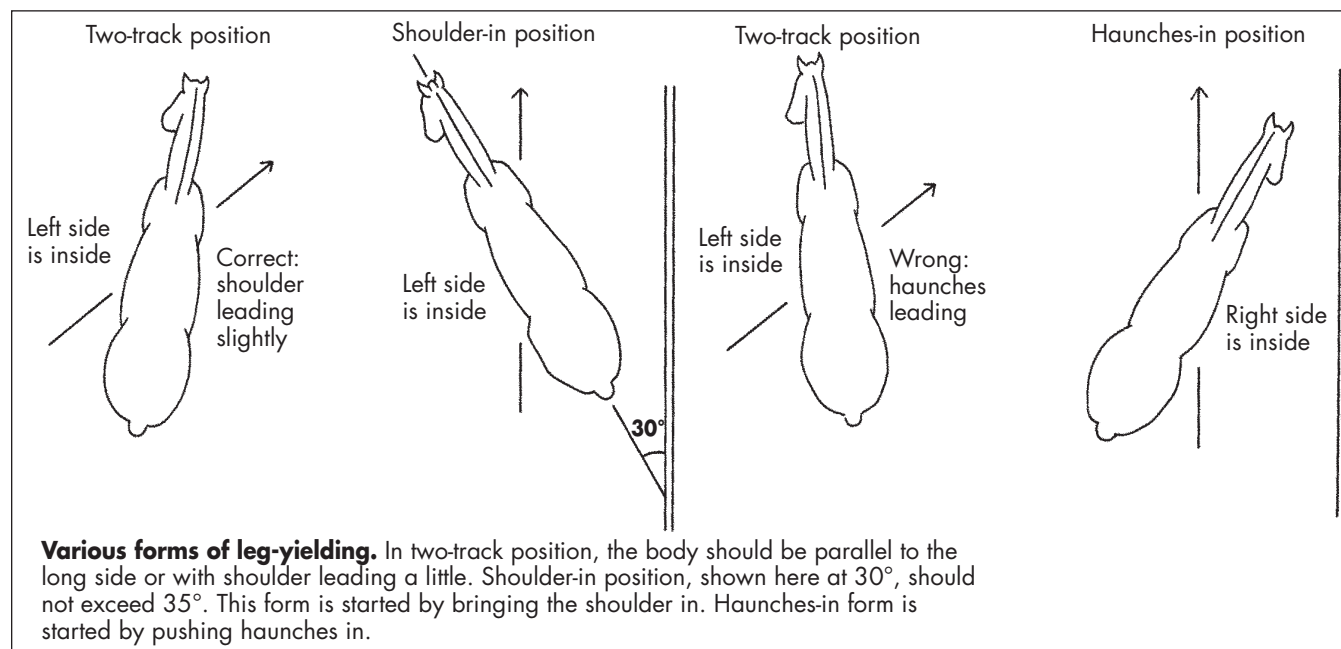

## Lengthened trot

While maintaining the same cadence as a working trot, the horse lengthens its steps as a result of increased impulsion from the hindquarters. The rider allows the horse, while remaining on the bit without leaning on it, to lengthen its **frame** and to gain ground. The forefeet should touch the ground on the spots toward which they are pointing. The hind feet should overstep the front feet by at least a hoofprint.

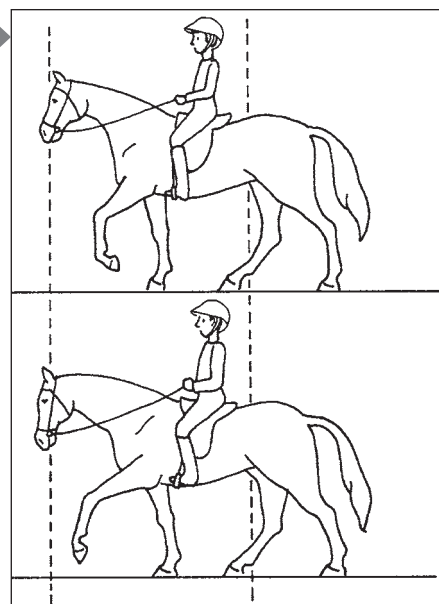

## Lightness

The horse's ability to move with agility and ease as a result of impulsion, suppleness, balance, and freedom of movement.

## Longitudinal bending

The bending of the spine in a vertical plane by the flexing of the poll, raising the neck, rounding the back, and lowering the croup. Required in **collection**.

## Medium canter

The horse goes forward with free, balanced, and moderately extended strides and an obvious impulsion from the hindquarters. The rider allows the horse, while remaining on the bit, to carry its head a little more in front of the vertical than at the collected and working canter. At the same time, the horse is allowed to lower its head and neck slightly. The strides should be as long and even as possible and the whole movement balanced and unconstrained.

## Medium trot

A pace between the working and extended trot but more "round" than the latter. The horse goes forward with free and moderately extended steps and an obvious impulsion from the hindquarters. The horse remains on the bit, carrying its head a

little more in front of the vertical, with head and neck lowered slightly. The strides should be as even as possible with movement balanced and unconstrained.

### Medium walk

(Training through Second Level)

A regular and unconstrained walk. The horse should walk energetically but calmly, with even and determined steps, the hind feet touching the ground in front of the footprints of the forefeet. The rider should maintain a light, soft, and steady contact with the horse's mouth.

### On the aids

The horse responds instantly and generously to all aids, accepting the contact and maintaining connection from croup through the back to the poll.

### On the bit

The horse's neck is raised and arched, according to the stage of training and the **extension** or collection of the pace, and the horse accepts the bridle with a light and soft contact while remaining submissive throughout. The head should remain in a steady position slightly in front of the vertical, with a supple poll as the highest point of the neck. The horse should offer no resistance to the rider.

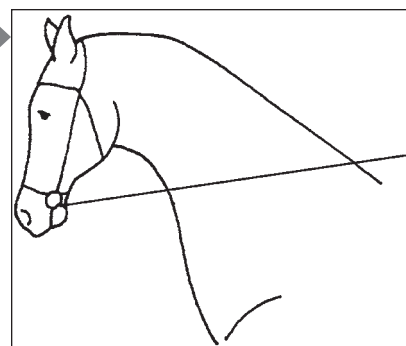

### Outside

The side away from which the horse is bending.

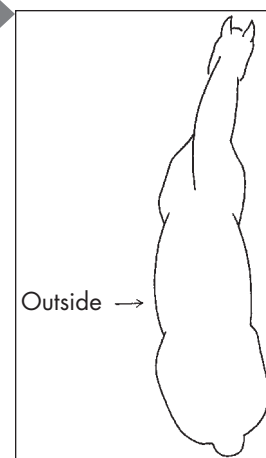

### Overbent

Excessive lateral displacement of the neck relative to the body, occurring in the neck itself or at the base of the neck, causing lack of apparent uniformity of the lateral curve of the horse.

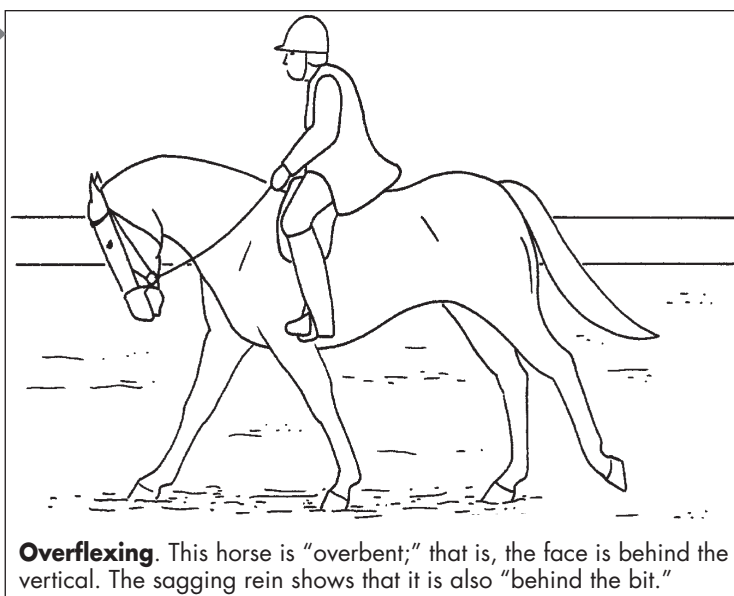

**Overflexing.** This horse is "overbent;" that is, the face is behind the vertical. The sagging rein shows that it is also "behind the bit."

### Position

The direction in which the horse looks. While flexed at the poll, the horse can be positioned with the rider's leg to the left or the right. The rider sees the outside edge of the horse's eye and nostril on the side to which he is positioned. The horse can be ridden forward in position left or right as a suppling exercise.

### Reading the test by a caller

All tests may be called except at any final or championship class, or during the dressage phase of a combined test. If the tests are announced, it is the responsibility of the competitor to arrange for a person to call the test. Lateness and errors on the part of the caller will not relieve the rider from “error penalties.” Calling is limited to reading the movement exactly as it is written, one time only. Repeating of movements constitutes unauthorized assistance, which is prohibited and is cause for elimination. If there is reasonable doubt that the rider did not hear the original call, it may be repeated without penalty.

### Regularity

Refers to either the repeated rhythm in the horse’s gaits as they are defined or to the regularity of the tempo.

### Renvers

The inverse movement in relation to **travers**, with the haunches instead of the head to the wall.

### Rhythm

The order of the footfalls. The beat of the gait. The **walk** has four beats, the **trot** has two beats, and the **canter** has three beats plus suspension.

### Riding through a corner

The horse should adjust the bend of its body to the curve of the line it follows, remaining supple and following the direction of its rider without any resistance or change of pace, rhythm, or **frame**.

### Salute

A movement executed at the **halt** to signal the beginning and ending of a test. The rider must take the reins and whip in one hand, letting the other arm drop loosely along the body, and then nod the head forward in a slight bow.

### Scale of marks/scoring

A system for awarding scores to all movements as well as **collective marks** and certain transitions from one to another in a judged test. Scores range from 0 to 10, with 0 being the lowest and 10 the highest. See page 25 for a description of the marks.

### Self-carriage

The natural and correct carriage of a horse without taking support or balancing on the rider’s hand.

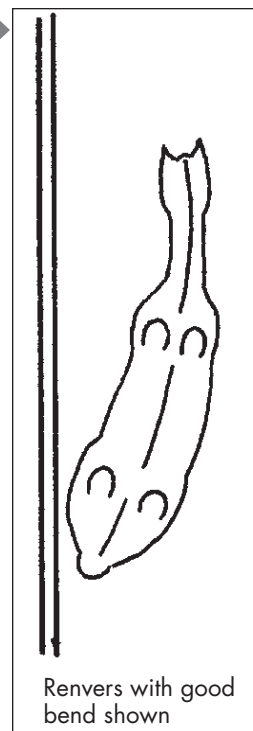

### Serpentine

A movement of at least three equal half-circles performed on a line changing the bend upon crossing an imaginary center line beginning at A or C as indicated on the test.

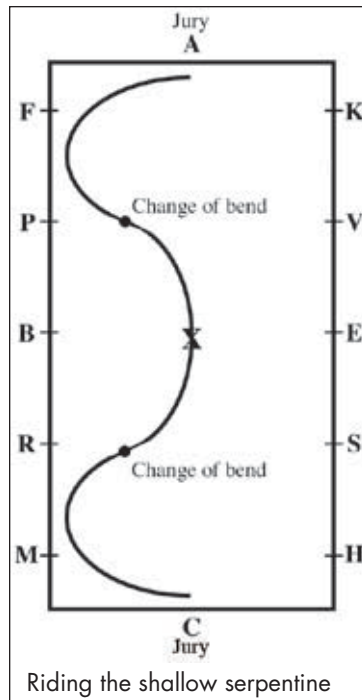
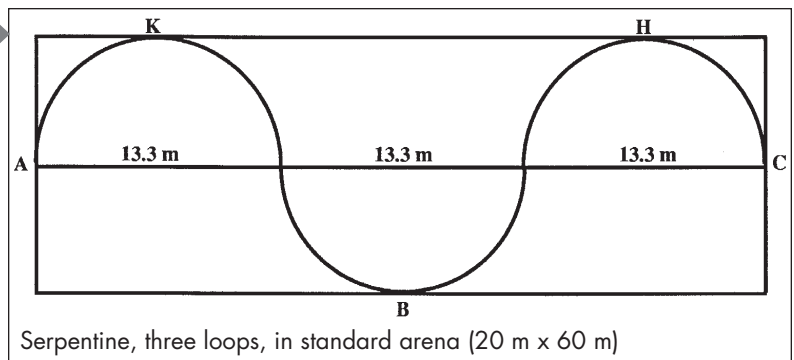
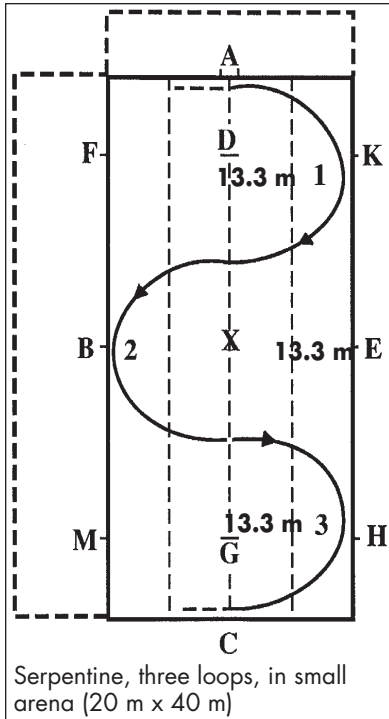

### Shoulder-in

The horse is slightly bent round the inside leg of the rider. The horse's inside foreleg passes and crosses in front of the outside leg; the inside hind leg is placed in front of the outside leg. The horse is looking away from the direction from which it is moving.

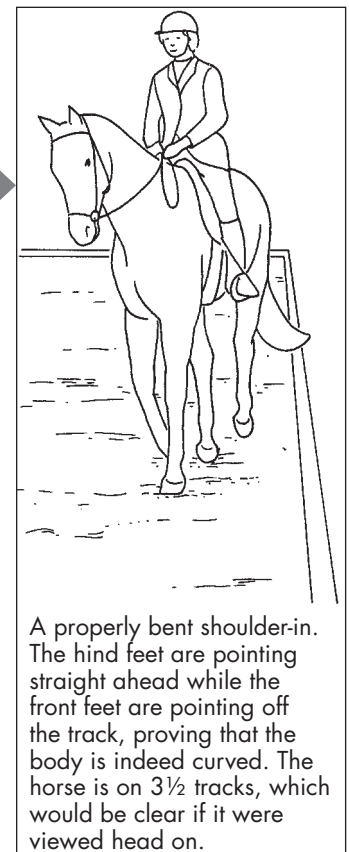
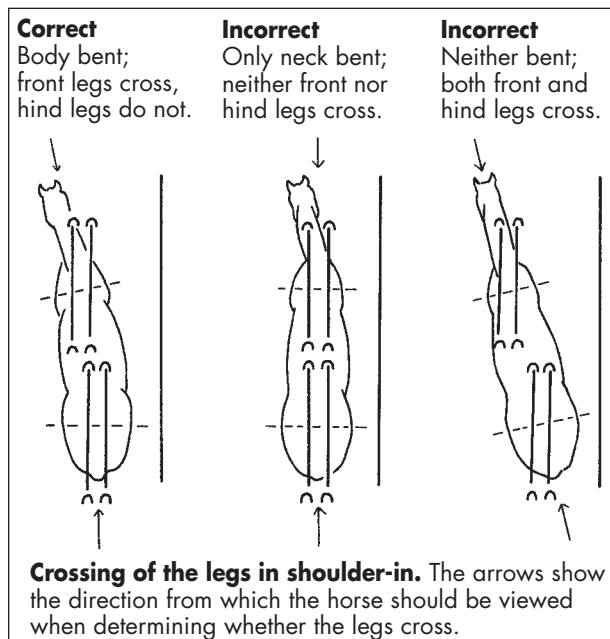

### **Simple change of lead at the canter (dressage only)**

Change of lead where the horse is brought back into a walk and after two to three steps is restarted with the other leg leading.

### **Snaffle bit**

Any bit with a direct pull on the mouth and no leverage. The bit may or may not be jointed.

### **Submission**

The degree of submission is demonstrated by the way the horse accepts the bridle with a light and soft contact and a supple poll, while being responsive to the aids, willing to go forward balanced, and showing acceptance of the task at hand.

### **Suppleness**

The physical ability of the horse to shift the point of its equilibrium smoothly forward and back as well as laterally without stiffness or resistance. Suppleness is manifested by the horse's fluid response to the rider's restraining and positioning **aids** of the rein and to the driving aids of the leg and seat. Best judged in the **transitions**.

### **Suspension**

The moment or phase of the trot or canter in which the horse has no feet on the ground.

### **Tempo**

The rate of repetition of the rhythm. Tempo is not synonymous with speed (miles per hour).

### **Tracking up/overtracking/overstepping/overstriding**

The hind foot comes down on, or in front of, the print of the forefoot on the same side, at the walk or the trot, as a result of **engagement** of the hindquarter.

### **Training Level**

A level of competition to introduce the rider and horse to the basic principles of dressage competition. Requires obedience to the **aids** of the rider without fight or **evasion** when ridden on light contact. Desirable qualities are free, rhythmic, forward movement; relaxation and obedience; and stretching into the bit in a calm, receptive manner. Current test requirements are basic gaits, free walk, circles of 20-meter diameter, and progressive transitions (from the trot to halt through a few steps of walk).

### **Transition**

The change from one gait to another. Change of gait and/or speed should be shown clearly at the letter. Gaits should be precise, smooth, and not abrupt. The rhythm of a gait should be maintained up to the moment when the gait is changed or the horse halts. The horse should remain calm and light in hand and should maintain a correct position.

*Downward.* Such as, change canter to trot, or trot to walk.

*Upward.* Such as, change walk to trot, or trot to canter.



### Travers

A movement in which the horse is slightly bent round the inside leg of the rider. The horse's outside legs pass and cross in front of the inside legs. The horse is looking in the direction in which it is moving at an angle of 30°.

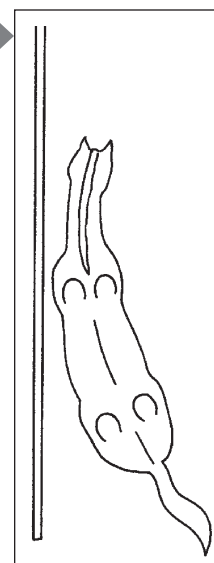

### Trot

A gait of "two-time" on alternate diagonal legs (i.e., left fore and right hind) separated by a moment of suspension. Steps should be free, active, and regular. The quality is judged by the general impression, the regularity and elasticity of the steps (which originate from a supple back and a well-engaged hindquarter), and the ability to maintain the same rhythm and natural regularity.

### Trot rising

When the rider rises at each alternate stride; posting.

### Turn on the forehand

A schooling exercise executed from the halt to teach the horse obedience. The horse's hindquarters are moved in regular, quiet steps in a circle around its forehand. The movement may be executed through 90°, 180°, or 360°. The rider draws his or her right leg back and applies it to the horse's side to move its quarters away to the left, pivoting on the "off foreleg," which should remain absolutely still. The horse is bent slightly to the right.

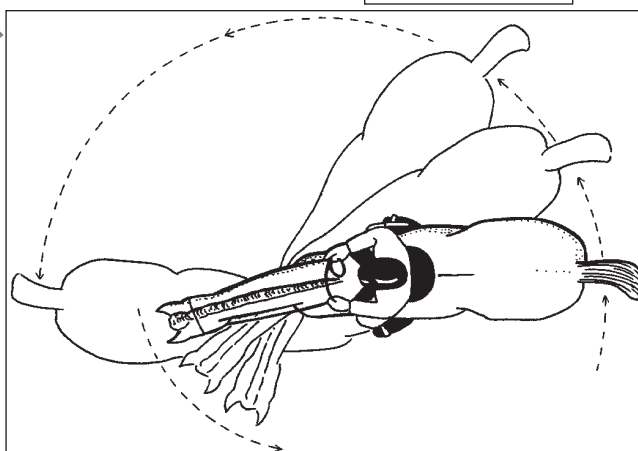

This turn is a pivoting movement with little impulsion or forward movement. From a standstill, the horse moves its quarters away from the rider's leg and thereby pivots round one foreleg. The turn can be through 90°, 180°, or 360°.

### Turn on the haunches

A schooling exercise that can be executed from the **halt** or a **walk**. The horse's forehand moves in even, quiet, and regular steps around its inside hind leg while maintaining the rhythm of the walk. In the half-turn on the haunches, the horse is not required to step with its inside hind leg in the same spot each time it leaves the ground, but may move slightly forward. Backing or loss of rhythm are severe faults. Movement may be executed through 90°, 180°, or 360°.

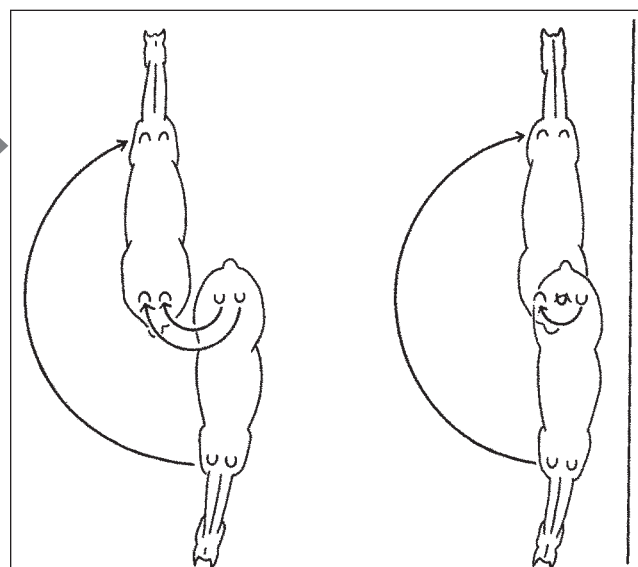

**Half-turn on the haunches to the right.** The diagram shows both the lower level half-turn, with the inside hind foot making a small circle, and the more advanced pirouette, in which it steps on one spot.

### Überstreichen

A clear release of contact where the horse maintains self-carriage, rhythm, straightness, and quality of canter.

### Unevenness

Irregularity of rhythm or gait whereby one diagonal moves deeper than the other.

### Unlevel

The horse dropping more heavily on one leg; possible lameness.

### Voice

In performing a test, the rider using his or her voice in any way or clicking his or her tongue will result in the deduction of 2 points for each occurrence from the marks that otherwise would have been awarded for the movement.

### Volte

A circle 6 meters in diameter. If larger than 6 meters, use the term "circle" and state the diameter.

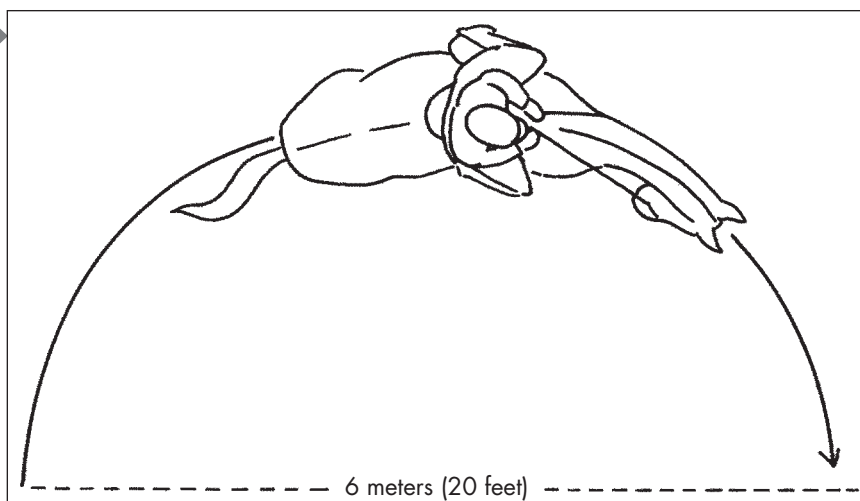

### Walk

A marching gait in which the footfalls of the horse's feet follow one another in "four-time," well-marked and maintained in all work at the walk. Faults: when the four beats cease to be distinctly marked, even, and regular, becoming disunited, broken, or **lateral**.

### Wandering

Deviation from a straight line.

### Working canter

A regular canter, in which a horse not yet ready for collected movements shows itself properly balanced and remaining "on the bit," and goes forward with even, light, and cadenced strides and good hock action, with **impulsion** originating from the activity of the hindquarters.

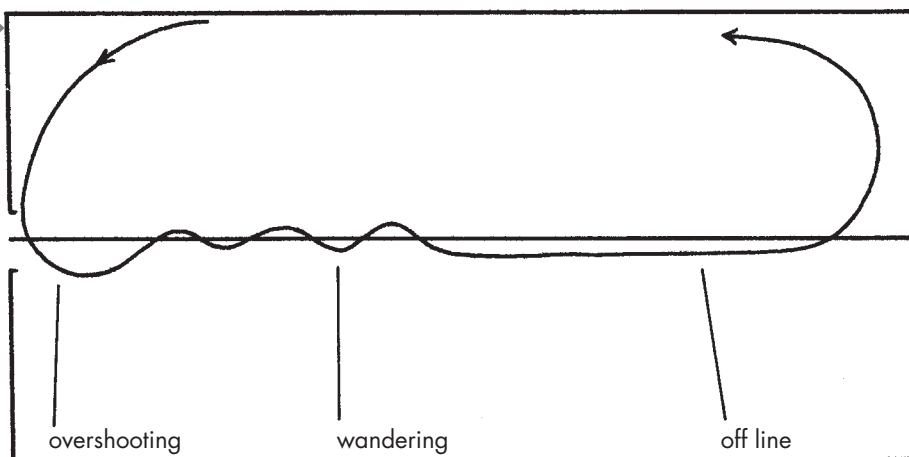

### Working trot

A regular trot, in which a horse not yet ready for collected movements shows itself properly balanced and remaining "on the bit," and goes forward with even, elastic steps and good hock action, with **impulsion** originating from the activity of the hindquarters.

# Levels of Competition

## U.S. levels

Dressage in the United States is governed by the following groups, which set standards and rules for the sport:

- United States Equestrian Federation (USEF)
- United States Dressage Federation (USDF)
- United States Equestrian Team (USET)
- Federation Equestre Internationale (FEI).

These organizations standardize tests and rules of competitions and set standards of judging.

In the United States, there are six levels of competition. Each is successively harder than the preceding one. All lead to the international levels of competition.

The objectives and standards of the Dressage Levels are as follows.

### **Introductory Level**

USDF Introductory Level Tests provide an opportunity for the horse and/or rider new to dressage to demonstrate the elementary skills. All trot work is to be ridden rising. The rider should maintain light but steady contact except at the free walk, in which the horse is allowed complete freedom to lower and stretch out its head and neck. The tests have been designed to encourage correct performance and to prepare the horse for transition to USEF tests.

### **USEF Levels**

#### **Training Level**

Training Level introduces the rider and horse to the basic principles of dressage competition. This level requires “obedience” to the **aids** of the rider without fight or **evasion** when ridden on light contact. The rider is searching for free, rhythmic, and forward movement. The horse should be relaxed and obedient, stretching into the bit in a calm, receptive manner.

#### **First Level**

First Level determines that the correct foundation is being laid for successful training of the riding horse. The horse should move

forward freely in a relaxed manner and with **rhythm**. First Level tests require not only the “obedience” and “relaxation” qualities of the Training Level, they require that the horse shows “soft response” to the aids. Examples of this are softening of the lower jaw, some flexion at the poll, **lateral** bending, lengthening at the **trot** and **canter**, and quiet **transitions**.

#### **Second Level**

Second Level determines that the horse has acquired, in addition to those qualities of the First Level, a degree of suppleness, balance, and **impulsion**. In the Second Level tests, the rider must now add “accuracy” and be able to put the horse to the aids, i.e., put the horse on the bit and keep it there without fight or evasion and without shortening the strides. The neck must be relaxed with the nose slightly in front of the vertical.

#### **Third Level**

The Third Level tests are of medium difficulty, and their purpose is to establish that the horse has acquired a greater degree of suppleness, balance, and lightness in hand than at Second Level. The horse also must remain reliably on the bit, producing more impulsion through further strength in the haunches and relaxation of the back and poll; this enables the rider to collect and extend the horse’s gaits. Third Level tests require that the proper foundation for **collection** and distinction between the paces has been attained by the horse.

#### **Fourth Level**

The Fourth Level tests are of medium difficulty and designed to determine that the horse has acquired a high degree of suppleness, impulsion, balance, and lightness while always remaining reliably on the bit; that its movements are straight, energetic, and **cadenced** and the transitions precise and smooth. The Fourth Level horse must show complete obedience, relaxation, collection, and **extension**. The horse must go fully on the bit without evasion of any kind. Such a horse is prepared to proceed to the

International Level tests upon completion of this level.

## **International levels**

Following satisfactory completion of Fourth Level, the horse proceeds to the International Levels governed by the FEI. These are used in all countries showing advanced dressage.

### **Prix St. Georges**

The first test is Prix St. Georges, which is a test of medium standard. This level shows the horse's submission to all demands in the execution of classical equitation. The horse shows a standard of physical and mental balance and development, which enables it to perform with harmony, lightness, and ease.

### **Intermediate Competition 1**

Next is Intermediate 1, which is a test of advanced standards. The object of this test is to lead horses on to the more demanding exercises of the Intermediate 2.

### **Intermediate Competition 2**

Intermediate 2 is a second test of advanced standards. The object of the test is to ease the path for horses that are on their way to, but not yet ready for, the Grand Prix and its fundamental "airs and graces" of the classical high school.

### **Grand Prix**

The Grand Prix test is of the highest standard. The Grand Prix is a competition of artistic equitation. It brings out the horse's perfect lightness, with a total absence of resistance and complete development of impulsion. The test includes the school paces and all the fundamental airs of the classical high school. However, the classical high school leaps (courbette, capriole, levade), which are obsolete in many countries, are not part of this test.

### **Grand Prix Special**

The Grand Prix Special is a test of the same standard as the Grand Prix, although slightly shorter and more concentrated. In this test, the transitions are especially important.

All FEI tests must be ridden from memory. By the time a horse and rider have reached these levels, their talents lie solely in the art of dressage. Actually, when advancing to collected medium and extended gaits in Second Level, the rider should decide whether the horse's talents lie in dressage. If not, the horse's training should be directed to other areas.

# How to Ride Dressage

This manual deals only with basic dressage. To compete and excel from Second Level upward, you should have a regular teacher and ride under a recognized authority on dressage. A dressage teacher should pass the same requirements as a dressage judge: be able to ride a horse at the level of his or her judging and to have trained a horse to that level.

## Where to get dressage training

The best way to learn any sport is to take lessons from someone who knows the game. Seek dressage instruction from a dressage rider. It is important that your teacher have a working knowledge of dressage principles. Also, riding is dependent upon feeling and sensitivity. To know a movement is correct, you must learn how it feels when it is correct. Only someone who has been there and felt the movement can help you.

Periodically, have an experienced person on the ground tell you when something is

correct. That person can see if the horse is moving forward in its tracks—if its head is in the correct position, and if the horse is bent and positioned correctly.

As you have read in this manual, the horse goes progressively from (1) “accepting contact” to (2) “accepting the bit” to (3) “on the bit” to (4) remaining reliably on the bit. Following are sketches of the **frame** of the horse at different achievement levels.

Don’t expect your horse to advance more than one level per year. This is the very best it can do. Also, don’t be disappointed if it doesn’t progress as fast as that. Do, however, demand that every advancement be correct and as nearly perfect as possible.

Local dressage organizations hold clinics, during which expert instructors teach. Usually, the public is invited to watch and learn. Often, you can ride your horse in a lesson for a fee. Such organizations and the contact for each are listed in the “Resources” section of this manual (page 27).

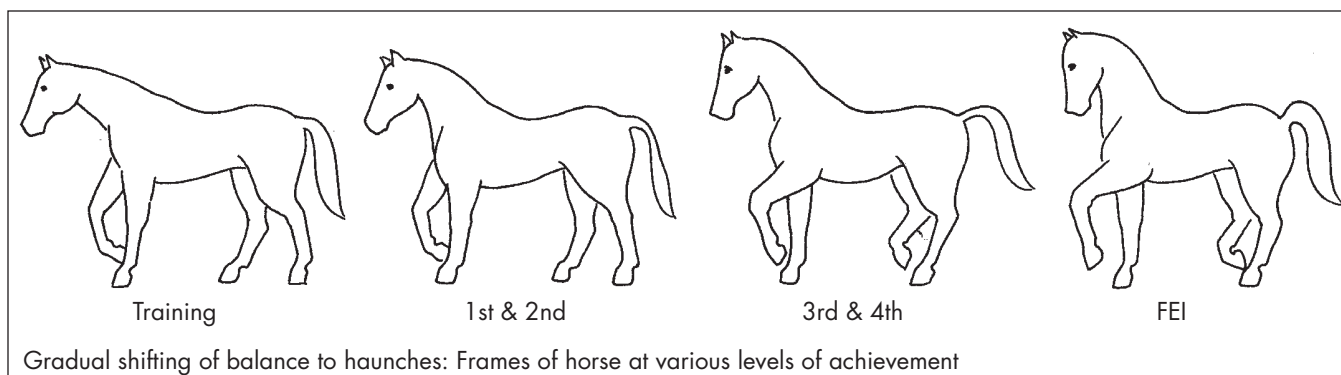

# General Rules

Because not every situation can be provided for in a set of rules, it is the duty of the judge (or jury) to make a decision in a sporting spirit to comply with the intention of the rules. For circumstances not specifically covered in this manual, refer to “Resources” on page 27.

## Dress

The open competition dress code for Training through the Fourth Level is a short riding coat, a tie (choker or stock tie), breeches or jodhpurs, hunt boots or jodhpur boots, and an approved riding helmet. Riders with long hair should wear hairnets. Gloves, half-chaps, spurs (English type and rowels must turn), and whips are optional. See *4-H Horse Contest Guide* (PNW 574) for specific guidelines.\*

## Saddlery and equipment

An English hunt-type or dressage saddle with stirrups is required. For the Training Level through Third Level tests, a plain snaffle bridle and regular cavesson, a **dropped noseband**, a **flash noseband** (a combination of cavesson and dropped), or a crossed noseband made entirely of leather or leatherlike material (except for buckles) is mandatory. For more information and illustrations, see *The 4-H Horse Project* (PNW 587), page 103.

Martingales of any kind, bearing side or running reins, seat covers, boots or bandages of any kind, bit guards, and any form of blinders are forbidden while competing or during warmup. Running martingales, boots, bandages, and side reins are permitted during warmup **only when longeing**.

\*See U.S. Equestrian rules for equipment options/changes for Third Level and above.

### Permitted snaffles (required Training through Second Level, optional in Third)



A. Rubber unjointed ordinary snaffle



B. Eggbutt snaffle

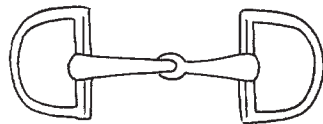

C. Dee snaffle

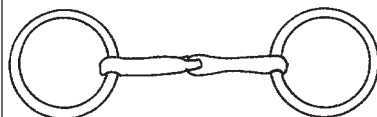

D. Ordinary snaffle with single jointed mouthpiece

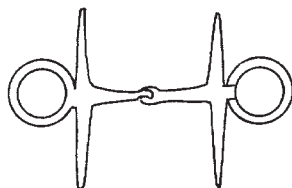

E. Fulmer snaffle

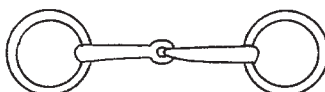

F. Small ring snaffle

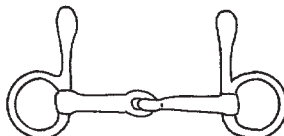

G. Snaffle with upper cheeks only

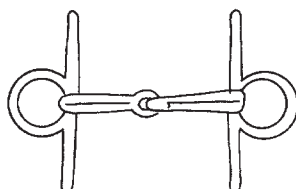

H. Full cheek French snaffle

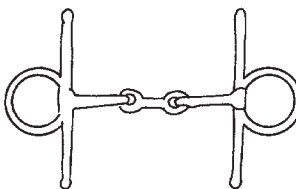

I. Full cheek double-jointed

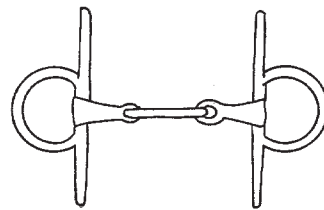

J. Dr. Bristol mouthpiece, any cheek

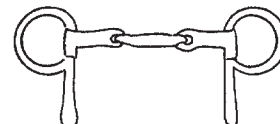

K. Half-cheek double-jointed with lower cheeks

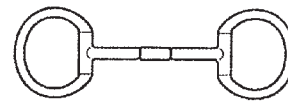

L. Myler bit (snaffle with rotating mouthpiece)

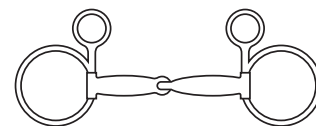

M. Baucher snaffle

**Note:** These snaffles may be covered with rubber or leather providing the bit is made of metal or rigid plastic. Flexible rubber bits are not allowed.



All bits must be smooth and solid. Twisted, wire, and roller bits are prohibited.

## Dressage competitions

Dressage competitions are open to all 4-H members riding horses, ponies, or mules. You can request tests from your local Extension office. Tests may be read but must be limited to reading the movement as it is written. A movement may be read only once. Repeating of movements or other instructions may constitute unauthorized assistance and could be cause for elimination. If there is reasonable doubt the rider heard the original call, it may be repeated without penalty.

When a competitor makes an **error of the course** (takes a wrong turn, omits a movement, etc.), the judge (or jury) gives warning by ringing the bell or blowing a whistle. The judge may then show the rider the point at which the test is to be resumed, and leave the rider to continue. Every “error of the course,” whether the bell is rung or not, must be penalized as follows:

1. First time—2 points
2. Second time—4 points

3. Third time—The rider is eliminated. He or she may continue the performance with scores not to count.

Horses should be clean and in good condition as stated in other 4-H contest rules. Their manes may be braided or left natural with no penalties or advantages.

## Arenas

All tests are ridden in either the small arena (20 by 40 meters) or the large arena (20 by 60 meters) (1 meter equals 3.3 feet). The enclosure itself should consist of a low fence about 0.30 meter high, with part of the fence at A easy to remove, so competitors can enter and leave in a suitable way.

Letters outside the arena should be placed about 0.50 meter (18 inches) from the fence and clearly marked. It is permissible to decorate the letters and the judge’s stand with flowers and greenery. The judge’s stand should be 5 meters (16 feet) from the end of the arena, opposite the letter C. The arena should be on ground as level as possible, with safe footing, free of rocks and obstructions. See **Dressage arena** in the glossary for an illustration of standard and small arenas.

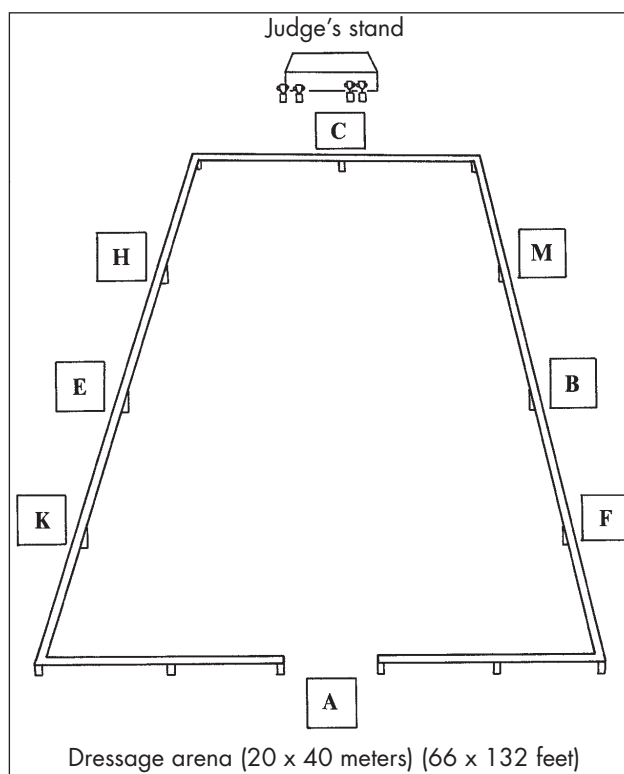



# Riding Your Training Level Test

The following steps describe the proper procedure for a dressage test.

## 1. Report.

Report early enough before your assigned ride time to check in with the show office and accustom your horse to the grounds and show arena.

## 2. Know the test.

You may ride from memory or have it read aloud. If you choose to have a reader, you are responsible for any errors that occur from incorrect reading or from your not hearing the reader.

## 3. When to begin the test.

When the previous competitor has made his or her final salute, you may begin your warm-up around the outside of the dressage arena. When the signal is given by the judge (bell or whistle), you have 45 seconds to enter the arena at A.

Do not rush. Plan your turn onto the center line, keeping a straight line to X, and looking toward the judge's stand at all times. Remember, your legs, not your reins, keep the line straight. Your trot should be calm and forward, relaxed and obedient. Your horse should stretch into the bit in a calm, receptive manner.

## 4. Halt.

The halt should be square and immobile in preparation for the salute. The horse should be quiet and accept the bit calmly.

## 5. Salute.

If you are carrying a whip, put it, along with both reins, into one hand. Drop the other hand to your side, and acknowledge the judge with a nod of your head. Return your hand to the reins, adjust your grip of the whip, and prepare to go forward at the trot after the judge returns the salute.

## 6. Depart from X.

Proceed with a calm, forward, obedient trot; remember to continue with the same straight line you had approaching X. Plan a good balanced turn at C; ride deep into corners with your outside leg behind the girth to bend hindquarters around the inside leg; keep your horse straight going down track.

## 7. Circles.

In the Training Level, circles are 20 meters. Circles have only four touch points. The horse should be bent around the inside leg, looking in the direction it is traveling. The outside leg and rein maintain the proper size of the circle, not allowing the horse to swing its haunches out and fall into the corners or into the circle, thus making it smaller. A common fault of circles executed at Training Level tests is making them egg-shape.

## 8. Impulsion.

Making the horse travel faster is commonly mistaken for creating impulsion. Impulsion is thrust, created by the horse's desire to move forward with energy and elasticity of the steps. It is created by the relaxation

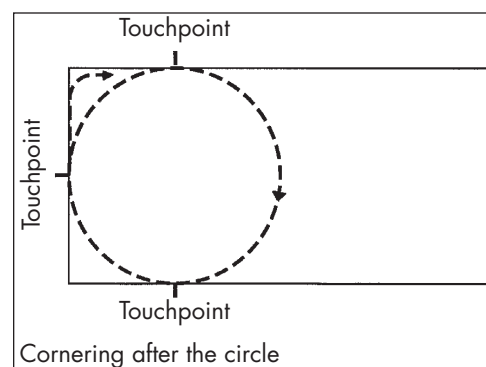
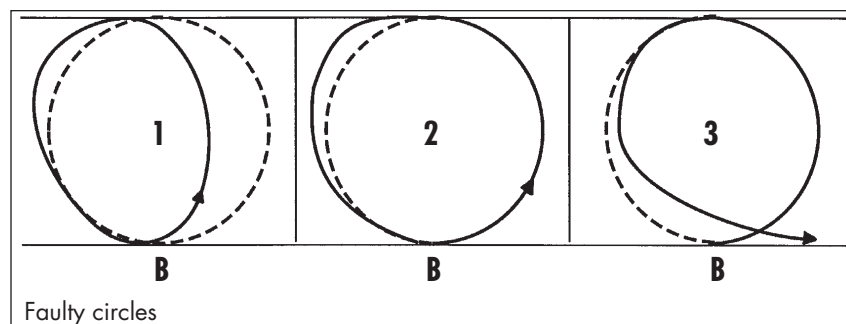

of the horse's back, done without the horse speeding up. Impulsion will be created if the horse is submissive to the rider. Submissiveness is evident if the horse accepts the bit and is attentive and confident.

## 9. Gaits

*Walk.* The walk is a marching gait in which footfalls follow one another in "four time." In Training Level, the horse demonstrates a medium walk and a free walk on a long rein.

The *medium walk* should be free, regular, and unconstrained, with moderate lengthening. The horse should remain on the bit, walking energetically, calmly, with the hind feet touching the ground in front of the footprints of the forefeet. The rider should maintain a soft and steady contact with the horse's mouth.

The *free walk* is a gait of relaxation in which the horse is allowed complete freedom to lower and stretch out its head and neck.

*Working trot.* A gait of "two time" on alternate diagonal legs separated by a movement of suspension. The trot should be free, active, and with regular steps. The quality of the trot is judged by the general impression and the regularity and elasticity of the steps, which originate from a supple back and well-engaged hindquarters, and maintain the same rhythm and natural balance. In the dressage test, the sitting trot is kept at the same pace and impulsion as when posting, except that the rider remains seated.

*Working canter.* The horse shows itself properly balanced and remaining "on the bit" and goes forward with free, balanced, and moderately extended strides and with an obvious impulsion from the hindquarters. It avoids a "four-beat" canter, a common fault often seen in this gait. The horse should be straight, with the inside hind foot in the same track as the inside front foot. Haunches should not be allowed to swing to the inside or outside of the track. When asking for a canter depart, the horse should be bent, at the poll, to the inside rein, looking in the direction it is going.

## 10. Transitions.

All transitions, up or down, should be smooth, distinct, and with impulsion. The rider must use as much leg as hand in order to achieve a nice transition. The leg maintains the forward movement necessary for the horse to move smoothly into the next gait and keep a rhythmic pace.

## 11. Change of rein.

The rider changes direction across the diagonal. As the horse's nose comes to the wall letter where the turn begins, bend it with the inside leg and rein to make a smooth arc into the diagonal line. Maintain the horse straight and steady. At X, change the horse's bend and the rider's posting diagonal; continue to the next corner letter and bend smoothly onto the track. You have completed a change of direction.

## 12. Completion.

All tests are finished with a final halt and salute after turning down the center line. This salute is done exactly as the beginning one. Wait for the judge to nod before leaving the arena on a loose rein. You may continue down the center line, turn at C and go along the track, or simply turn to the track from X in order to leave the arena at A. Always exit at the walk.

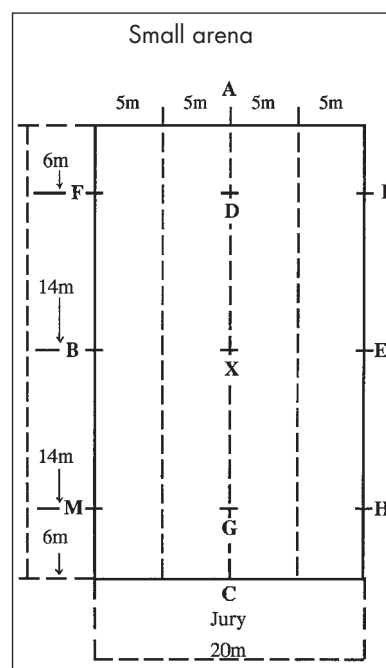

## How the Test Is Judged

Your percentage score will be posted by the show committee as soon as the class is completed. The judge evaluates your ride based on the following manner of scoring.

Each movement is scored on 0 to 10 points. The points are totaled and divided by the possible number of points to give you a percentage score. The distribution of points and the judge's opinion are shown in the chart.

Points	Rating	The Judge's Opinion
10	Excellent	Perfect; no improvement possible (rarely given)
9	Very good	Movement hard to fault, but not quite perfect (rarely given)
8	Good	Outstanding; lovely to watch (occasionally given)
7	Fairly good	Performed nicely, movement above average
6	Satisfactory	Movement correct
5	Marginal/sufficient	Okay, neither good nor bad, noncommittal score
4	Insufficient	Performed but lacking in precision and/or control
3	Fairly bad	No precision, little control or response to aids
2	Bad	No response to aids
1	Very bad	No control
0	Not performed	Rarely given

### Causes for elimination

Horse and rider combination shall be eliminated from the competition under the following circumstances:

1. Misrepresentation of entry
2. Dress code violations (at the discretion of the Ground Jury)
3. Use of illegal equipment
4. Unauthorized assistance
5. Third error of the course
6. Horse's tongue tied down
7. Late entry into the arena (must enter within 45 seconds)
8. All four feet of the horse leave the area during the test
9. Cruelty
10. Marked lameness
11. Resistance of longer than 20 seconds (balking)
12. Concern for safety of rider, other exhibitors, or their entries
13. Performing movements which are not allowed
14. Evidence of blood on a horse in the competition arena or outside the arena

15. Failure to wear competitor number
16. Any situation in which nonconformity to a direct rule can be cited

### More on how the test is judged

1. In judging a test, each movement should be scored to establish whether the movement is performed insufficiently (4 points or below) or sufficiently (5 or above).
2. Accuracy should be a bigger factor if the error avoids the difficulty of the maneuver.
3. Repetitive problems (shying, stumbling, tail-wringing, etc.) should be scored more harshly each time they appear.
4. If the horse grinds its teeth or wrings its tail, these are signs of tenseness or resistance and should be considered in the marks for each movement as well as the collective marks.
5. If the horse and/or rider falls, the competitor will not be eliminated. The rider will be penalized by the effect of the fall on the execution of the movement being performed and also in the collective marks.

## Collective marks

These are given a coefficient; i.e., they are multiplied by 2 or 3 and added to the marks already totaled for the movements. Collective marks are scores for impression of the ride as a whole. They include:

1. Gaits (freedom and regularity)—multiplied by 2
2. Impulsion (desire to move forward, elasticity of the steps, suppleness of the back, engagement of hindquarters)—multiplied by 2
3. Submission (attention and confidence; harmony, lightness, and ease of movements; acceptance of the bridle; lightness of the forehand)—multiplied by 2
4. Rider's position and seat; correctness and effect of the aids—multiplied by 3

2007 Training Level Test 3					NO. 4-H	
Purpose: To confirm that the horse's muscles are supple and loose and that it moves freely forward in a clear and steady rhythm, accepting contact with the bit.					CONDITIONS:	
All trot work may be ridden sitting or rising, unless stated.					Areas: Standard or Small	
Halts may be through the walk.					Average Time: 5:00 (Std.) or 4:00 (Small)	
Introduce: Stretching circle at trot, 10m half circle at trot.					Maximum Possible Points: 250	
READER PLEASE NOTE: Anything in parentheses should not be read.						
Coefficient						
	TEST	DIRECTIVE IDEAS	POINTS	#	TOTAL	REMARKS
1 A X	Enter working trot Halt, Salute Proceed working trot	Straightness on centerline, transitions, quality of halt and trot	7		7	STRAIGHT C. LINE IMMOBILE + B. SLIGHTLY ↑ BIT
2 C E X	Track left Turn left Circle left 20m	Quality of turns at C and E, quality of trot, roundness of circle	7		7	Bal. Trans - TROT NICELY 4 WED - good
3 X B	Circle right 20m Turn right	Quality of trot, roundness of circle, quality of turn at B	7		7	Ditto
4 - A 5	Circle right 20m, developing right lead center first quarter of circle					
4	(Score for transition)	Calmness and smoothness of depart	6		6	PROMPT - BRACING AGA. HAND
5	(Score for circle)	Quality of canter, roundness of circle, straightness A to E	6		6	nds. MORE JUMP HANDS SLIGHTLY R. A-E
6 E-B B	Half circle 20m, near centerline working trot Straight ahead	Quality of canter, trot and bend, balance and smoothness of transition, straightness B to A	7		7	NICELY 4 WED INTO TROT STRAIGHT!
7 A	Medium walk	Quality of transition and medium walk	5		5	TRANS. UNBALANCED Tentative TROT - MORE
8 K-B	Free walk	Quality of free walk, straightness, and transition	5 <sup>+</sup>	2	10	RELAXED - nds TO MORE
9 B-M M	Medium walk Working trot	Quality of medium walk and working trot, transitions	6		6	BETTER M.W. - TRANS WILTING
10 - C 11	Circle left 20m, developing left lead center first quarter of circle					
10	(Score for transition)	Calmness and smoothness of depart	5		5	PROMPT + ROUND
11	(Score for circle)	Quality of canter, roundness of circle, straightness C to E	6		6	JUMP BETTER THAN DIE. ND TO MAINTAIN STRAIGHT
12 E-B B	Half circle 20m, near centerline working trot Straight ahead	Quality of canter, trot and bend, balance and smoothness of transition, straightness B to C	5		5	STUMBLER INTO TROT UNBAL - TROT BETTER B-C
13 C Before C	Circle left 20m, rising trot, allowing the horse to stretch forward and downward Shorten the reins	Quality of stretch over back, forward and downward into a light contact while maintaining balance and quality of trot	6	2	12	NICE STRETCH - nds. TO REACH 4 WED MORE
14 E X G	Half circle 10m to X Straight ahead Halt, Salute	Quality of trot, quality and bend of half circle E-X, straightness on centerline, quality of transition and halt	8		8	NICELY BENT + WED 1/2 0 - STRAIGHT C. ATTENTIVE
Leave arena at A in walk on a long rein						
COLLECTIVE MARKS:						
GAITS (freedom and regularity)			5	2	10	Energize Walks Canter nds nice jump
IMPULSION (desire to move forward, elasticity of the steps, suppleness of the back, engagement of the hindquarters)			6	2	12	
SUBMISSION (attention and confidence, harmony, lightness and ease of movements, acceptance of the bridle, lightness of the forehand)			6	2	12	
RIDER (position and seat, correctness and effect of the aids)			6 <sup>+</sup>	3	18	Legs!!
FURTHER REMARKS:					Subtotal: 149	
Precisely Ridden, Demo.					Errors: (---)	
UNUNDERSTANDING OF DRESSAGE BASICS.					Total Points: 149 (Max: 250)	
POLISH TRANS; USE LEGS TO MAINTAIN STRAIGHTNESS +					59.60%	
IMPULSION THRU OUT TEST. DEVELOP YOUR OBVIOUS						
POTENTIAL!! 😊					(B)	

## Resources

### Publications

*A Young Person's Guide to Dressage* by Jane Kidd. 1999. Compass Equestrian Ltd., Cadborough Farm, Oldberrow, Henley-in-Arden, Warwickshire, United Kingdom. 144 pages. ISBN 1-900667-55-X.

*Centered Riding* by Sally Swift. 1985. St. Martin's Press, New York. 224 pages. ISBN 0-312-12734-0.

*Common Sense Dressage: An Illustrated Guide* by Sally O'Connor. 1990. Half Halt Press, Boonsboro, Maryland. 178 pages. ISBN 0-939481-21-9.

*Dressage Essentials* by Jane Kidd. 1999. John Wiley & Sons, Inc., Hoboken, New Jersey. 160 pages. ISBN 1-58245-001-3.

*101 Arena Exercises: A Ringside Guide for Horse and Rider* by Cherry Hill. 1995. Storey Books, North Adams, Massachusetts. 224 pages. ISBN 0-88266-316-X.

*Practical Dressage Manual* by Bengt Ljunquist. 1983. Half Halt Press, Boonsboro, Maryland. 164 pages. ISBN 0-939481-63-7.

*Preparing for a Dressage Test* by David Trott and Penny Hillsdon. 2001. J.A. Allen & Co., Ltd., London. (Allen Photographic Guides). 23 pages. ISBN 0-85131-807-X.

*Progressive School Exercises for Dressage and Jumping: A Handbook for Instructors and Riders* by Islay Auty. 2001. Half Halt Press, Boonsboro, Maryland. 94 pages. ISBN 1-872119-38-7.

*Riding a Dressage Test* by David Trott. 2001. J.A. Allen & Co., Ltd., London (Allen Photographic Guides). ISBN 0-581318-08-8.

*Rule Book* by the United States Equestrian Federation, Inc. (revised annually). Lexington, Kentucky (<http://www.usef.org/content/rules/ruleBook/2004/>).

### Organizations

United States Equestrian Federation, Inc.  
4047 Iron Works Parkway  
Lexington, KY 40511  
Phone: 859-258-2472  
Fax: 859-231-6662

Oregon Dressage Society, Inc.  
880 NE 25th Ave., Ste. 2 - PMB #173  
Hillsboro, OR 97124  
Phone: 503-681-2337  
Fax: 503-681-3873  
E-mail: [office@oregondressage.com](mailto:office@oregondressage.com)  
Web: <http://www.oregondressage.com>

Oregon High School Dressage Program  
E-mail: [hischooldressage@ods.com](mailto:hischooldressage@ods.com)

Oregon Horseman Association (OHA)  
c/o Sherry Hunter  
25468 Jean's Road  
Veneta, OR 97487  
Phone: 541-935-0914  
E-mail: [sherrytg@aol.com](mailto:sherrytg@aol.com)

United States Dressage Federation (USDF)  
220 Lexington Green Circle, Ste. 510  
Lexington, KY 40503  
Phone: 859-971-2277  
Fax: 859-971-7722  
Web: <http://www.usdf.org>

USDF Region 6 Junior/Young Rider  
c/o Oregon Dressage Society, Inc.  
880 NE 25th Ave., Ste. 2 - PMB #173  
Hillsboro, OR 97124  
Phone: 503-681-2337  
Fax: 503-681-3873  
E-mail: [office@oregondressage.com](mailto:office@oregondressage.com)  
Web: <http://www.oregondressage.com>

Idaho Dressage and Eventing Association (IDEA)  
Caroline Herrmann, Treasurer  
P.O. Box 211  
Hammett, ID 83627  
208-591-0326  
Web: <http://www.idahodressageandeventing.org>

### Periodicals

Flying Changes  
19502 NE 134th Place  
Battleground, WA 98604  
Phone: 360-687-0203  
Fax: 360-687-4898  
E-mail: [mail@flyingchanges.com](mailto:mail@flyingchanges.com)  
Web: <http://www.flyingchanges.com>

EQUUS  
P.O. Box 57919  
Boulder, CO 80321-7919

Practical Horseman  
P.O. Box 927  
Farmingdale, NY 11737-9627

Dressage Today  
656 Quince Orchard Rd.  
Gaithersburg, MD 20878-9907

© 2009 Oregon State University

Published and distributed in furtherance of the Acts of Congress of May 8 and June 30, 1914, by the Oregon State University Extension Service, Washington State University Extension, University of Idaho Cooperative Extension System, and the U.S. Department of Agriculture cooperating.

The three participating Extension Services offer educational programs, activities, and materials—without regard to race, color, religion, sex, sexual orientation, national origin, age, marital status, disability, and disabled veteran or Vietnam-era veteran status—as required by Title VI of the Civil Rights Act of 1964, Title IX of the Education Amendments of 1972, and Section 504 of the Rehabilitation Act of 1973. The Oregon State University Extension Service, Washington State University Extension, and University of Idaho Extension are Equal Opportunity Employers.

**Published February 2009.** Replaces Oregon publication 4-H 1311. **\$4.00**