

AGRICULTURAL EXPERIMENT STATION
Oregon State College
Wm. A. Schoenfeld, Director
Corvallis

Circular of Information No. 237

March 25, 1941

THE HOP RED SPIDER AND DUSTING EQUIPMENT
FOR ITS CONTROL

by

H. E. Morrison, Assistant in Entomology
and
F. E. Price, Agricultural Engineer

SEASONAL HISTORY

Adult red spiders live throughout the winter on green vegetation in and about hop yards. They leave their winter host and migrate to hop plants during spring and summer (May to July). This is accomplished by crawling over the ground or by soaring through the air on silken threads. The rate of migration and development of the spiders on hop plants depends upon the warmth and dryness of the season.

INJURY

The red spiders seclude themselves on the under surfaces of hop leaves and spin silken webs. They suck the plant juices from the leaves and the appearance of greenish-white mottling of tender hop foliage signifies the first notice of plant injury. The leaves later turn bronze and fall from the plant. The spiders migrate up the plant as the season progresses and by harvest time may enter the maturing cones. When this occurs, the cones turn reddish brown and the market value of the crop may be greatly impaired. Red spiders will also greatly lower the vigor of the plant and contribute toward dormant hills the following year.

CONTROL

The practice of spraying hops for red spider control has proven expensive and in many instances ineffective. Recent investigations have shown that:

1. Spiders must be contacted on the under surfaces of leaves if they are to be controlled by either sprays or dusts
2. Most of present dusting equipment employed by growers is unsatisfactory in contacting the spiders. Some of this equipment can be modified into efficient units with small expenditures.
3. The rate of dusting should not exceed 4-5 miles per hour. More rapid rates of application will result in wasted material and unsatisfactory control.

4. Two materials have shown decided superiority over all materials tested during the last several years. These materials have shown 97-99 per cent kill when applied at the rate of 50 pounds per acre and are listed as follows:

<u>Trade Name</u>	<u>Chemical Name</u>
DN	Dinitro-O-cyclohexyl phenol.
D-4	Dicyclohexylamine salt of Dinitro-O-cyclohexyl amine.

PLANT INJURY

D-4 is decidedly safer on hop foliage than DN. Neither D-4 nor DN should be applied to hops when temperatures are likely to exceed 95 degrees F. for three days after application. Growers can guard against possible plant injury by watching weather forecasts. Neither DN nor D-4 should be applied to hops after they have been sprayed with oil.

HOP APHIS

Neither DN nor D-4 will control hop aphis. Nicotine dusts may be applied either before or after applications of DN or D-4 without affecting the efficiency of the dusts and without danger to hop foliage.

NUMBER OF APPLICATIONS

Under Oregon conditions, one application of either DN or D-4 will probably prove to be sufficient for red spider control. These materials will effectively control the hatching eggs for five to six days after application of the dust.

Care should be taken to sucker and strip hops in order that both lower and top sections of the plant can be contacted with either DN or D-4. Failure to do this is likely to result in reinfestation of the dusted plant and necessitate redusting.

COST PER ACRE

The cost of DN and D-4 is likely to vary somewhat in various parts of the state. D-4 has been quoted at $9\frac{1}{2}$ cents per pound while DN costs $8\frac{1}{2}$ cents. At the rate of 50 pounds per acre, these materials will approximate \$4.75 and \$4.50, respectively. Application costs are in addition to these figures but should not exceed .25 per acre.

EFFECT ON MAN AND ANIMALS

Neither D-4 nor DN is harmful to man or animals. These materials are organic dyes and will discolor hair, nails and woolen goods. The discoloration is not permanent but old cotton clothes should be worn when applying these dusts. The odor of DN and D-4 is not unpleasant and these materials can be applied without gas masks. Recent tests have also shown that these materials do not impair the manufacture of beer in any way.

METHOD OF APPLICATION

Unsatisfactory results will result with DN or D-4 if the materials are not properly applied. Speed of application should not exceed 4 to 5 miles per hour. Wind velocities should be at a minimum when the dusts are applied. Dew on foliage will aid in depositing the dusts on hop foliage.

DUSTING MACHINERY

Figures 1, 2, 3, and 4 show the types of dusting machinery which were used successfully on a commercial scale during 1940. Four (4) dust distribution pipes, each fitted with a fishtail nozzle spaced and pointed as shown in Figures 1 and 3 are very satisfactory in contacting the undersurfaces of the hop leaves.

These nozzles should be mounted on a pipe or angle iron stand for support. They should be mounted in a manner that will enable them to be adjusted for direction of discharge as well as height and width. This provides for flexibility of the duster, and it can be used for varying width of rows and height of trellis.

The duster shown in Figure 2 has a separate engine for the operation of the duster, while the one shown in Figures 3 and 4 is operated from a tractor take-off. Both types of dusters have proven satisfactory.

DIVISION OF THE AIR STREAM

There are two methods of dividing the air stream in order to provide an equal amount of dust to the four nozzles. Figure 2 illustrates the use of 3 Y's to divide the dust stream into the four outlets. This method is quite satisfactory if the dust is thoroughly mixed in the air stream before it reaches the first Y. However, the duster shown in Figure 2 discharges the dust into the air stream after the air leaves the fan and satisfactory mixtures of dust and air are not obtained. This duster is being discarded and will be replaced by a later type in which the dust is injected into the air stream ahead of the fan.

The second method of dividing the air stream is illustrated in Figures 3 and 4. It illustrates the mushroom type of distribution which was developed by the Hardie Manufacturing Company of Portland. This method divides the dust stream quite uniformly and has proven satisfactory in field use. This type of distribution undoubtedly causes slightly more friction loss than the Y's, but this is apparently not an important factor, because it is effective in uniform distribution between any number of laterals.

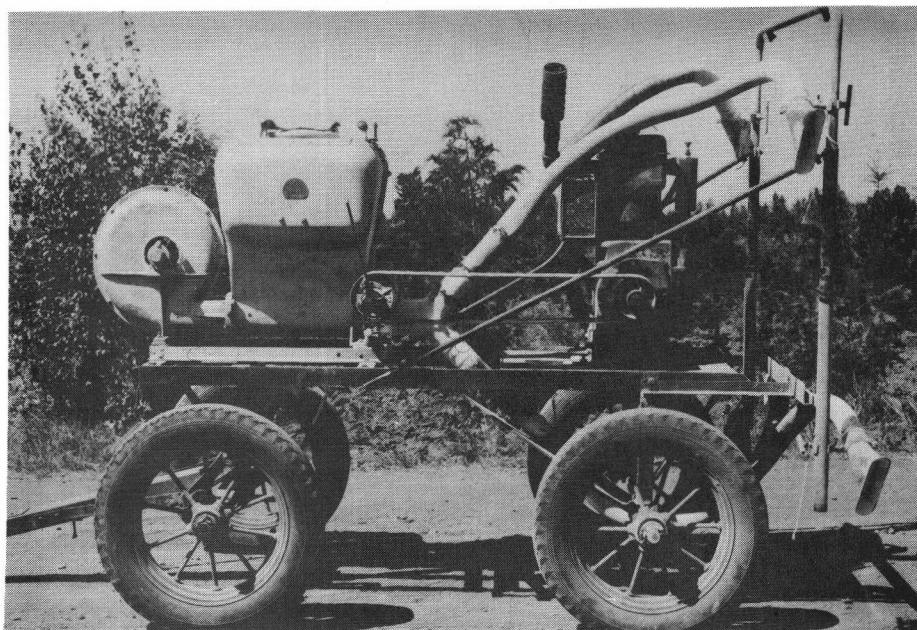

Fig. 2. Side view of hop duster used at O. S. C. Note Y's used to divide dust stream. Also note that this is old type duster with dust entering air-stream after the air leaves the fan. This type is quite inferior to the newer types which thoroughly mix the air and the dust by passing the dust through the fan. See Figures 3 and 4.

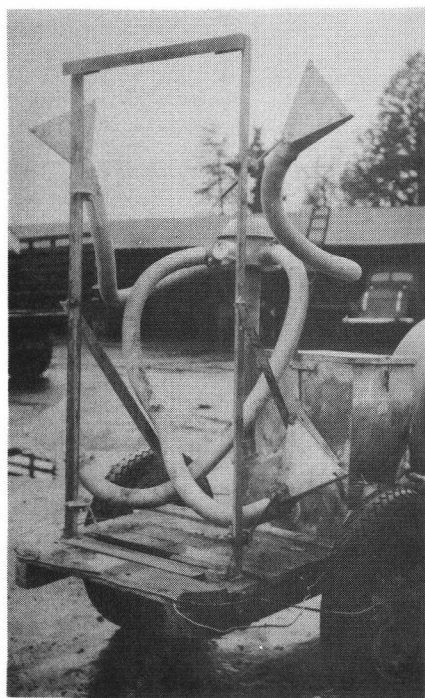

Fig. 3. This hop duster unit was very effective in control of red spider in 1940.

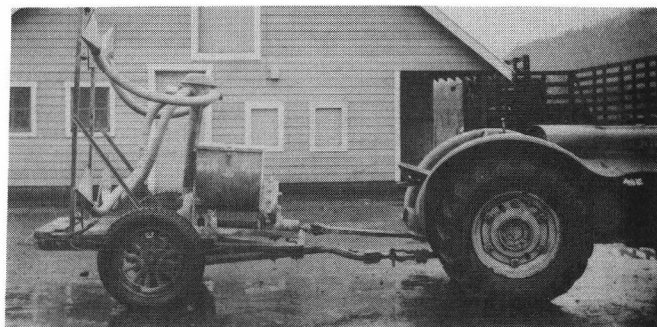

Fig. 4. Side view of hop duster. Note mushroom type of distribution head and tractor power take-off.

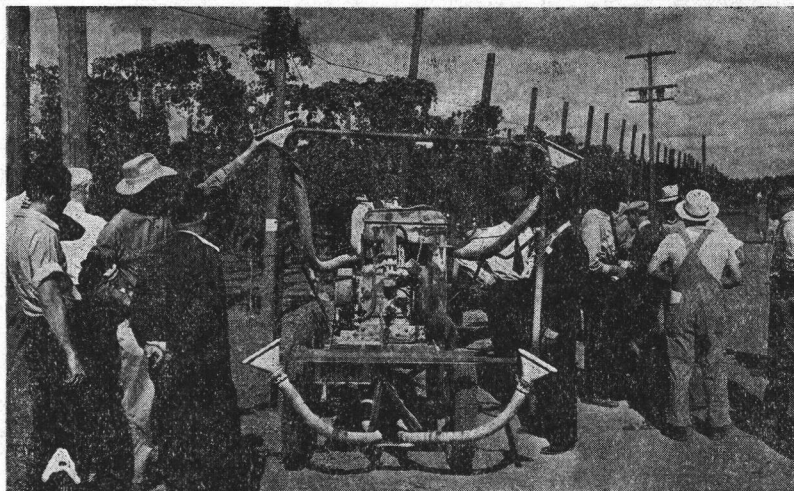

Fig. 1. Dusting equipment developed and used by Oregon Agricultural Experiment Station to successfully control hop red spider. Note the fishtail nozzles which direct dust to underside of leaves.

SPECIFICATIONS FOR DUSTING EQUIPMENT

1. Fan Requirements:
 - a. Cubic feet of air per minute: 800 to 1,000.
 - b. Static pressure required: 4 to 5 inches of water.
2. Diameter of flexible airlines to nozzle: 3 inches.
3. Four flexible discharge lines required with fishtail nozzles.
4. Size of nozzles: $1/8''$ x 10'' at discharge and 12 to 15 inches long.
5. Nozzles must be on adjustable mounting as shown in Figures 2 and 3.
6. Dust must be divided equally between four discharge lines.
 - a. By use of Y's.
 - b. By use of mushroom type distribution head.
7. Separate engine, or tractor power take-off, satisfactory to operate the duster.
8. Estimated power requirement: 3 to 4 horsepower.



Fig. 5. O.S.C. Hop duster in operation.

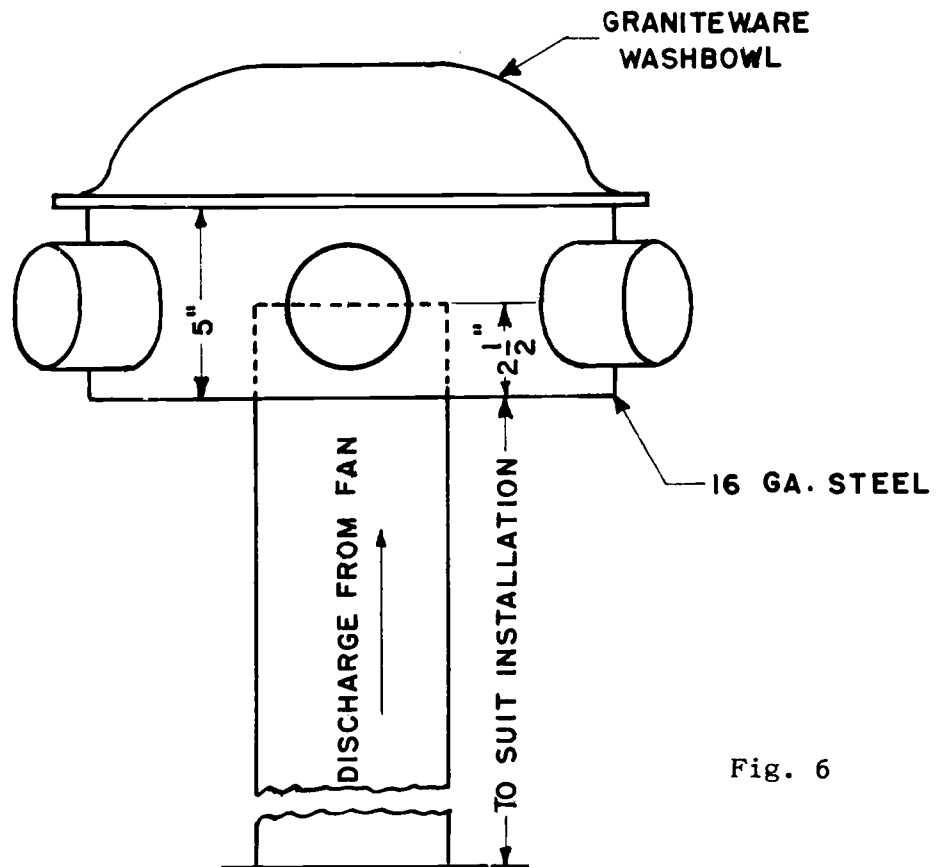
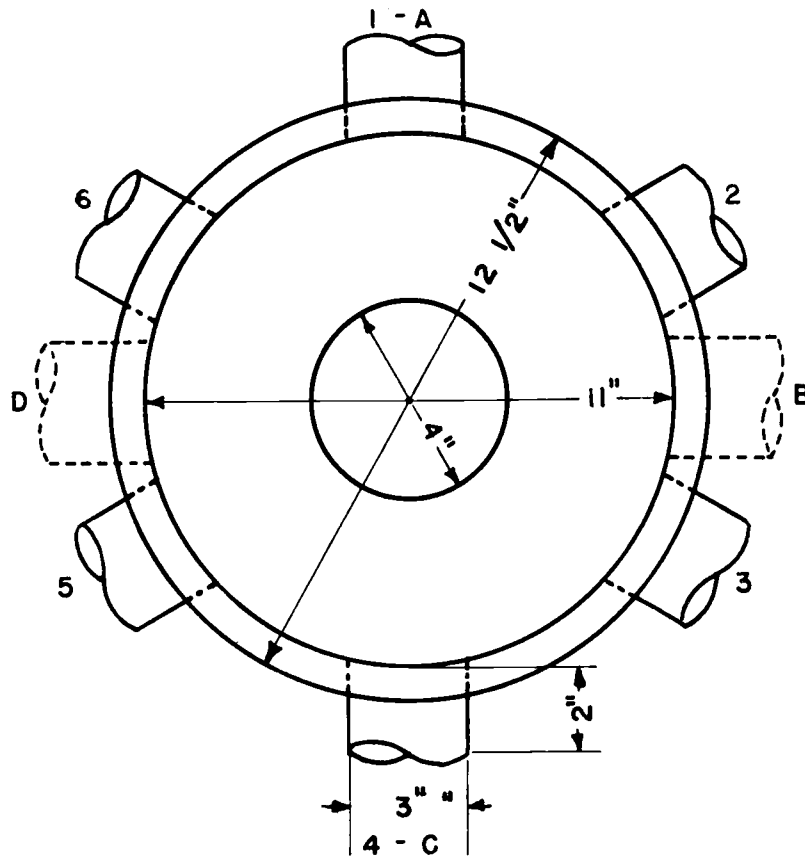

Fig. 6