



A New Method of Controlling Inlet Water Flow Rate in Solar Energy Water Distillation

FA. Rusdi Sambada^(✉) and I Gusti Ketut Puja

Department of Mechanical Engineering, Faculty of Science and Technology, Sanata Dharma University, Yogyakarta 55282, Indonesia
sambada@usd.ac.id

Abstract. Only some water can evaporate in the distillation process using wick-type solar energy. The more water that does not evaporate, the lower the distillation efficiency. A faucet generally uses for controls the inlet water flow rate. However, the faucet causes a significant flow rate. The greater the inlet water flow rate, the more water does not evaporate. This study examines a new method of controlling the flow rate of inlet water in wick-type solar energy water distillation using the principle of communicating vessels. The research was carried out experimentally in the laboratory using six infrared lamps as solar energy simulators. The distillation model used was 0.5 m² in size and 3 mm thick cover glass. The inlet water flow rate was varied by 3.6, 4.8, and 7.7 liters/hour. The results showed that the inlet water flow method using the communicating vessels principle could increase the efficiency of solar energy water distillation compared to controlling the flow rate of distillation inlet water using a faucet. The highest efficiency increases of 61% was obtained at a variation of the inlet water flow rate of 4.8 liters/hour.

Keywords: Inlet Water, Flow Rate, Efficiency, Communicating Vessels

1 Introduction

Communities living in urban areas generally are fine with getting drinking water. Apart from drinking water companies that the government manages, people living in urban areas can also buy bottled water quickly and cheaply. Very different from people who live in urban areas, people who live in remote areas find it very difficult to get drinking water. Apart from the absence of a drinking water network managed by the government, bottled water marketing generally does not reach remote areas. In meeting the need for drinking water, people in remote areas generally use existing water sources such as groundwater and rivers and even by collecting rainwater. However, water obtained from groundwater, rivers, or rainwater generally does not meet health requirements to be used as drinking water because it contains contaminants that are detrimental to health. Contaminants detrimental to health include soil particles, heavy metals, bacteria, salt, etc. Therefore, we need a simple technology that can purify contaminated water in remote areas to be fit for drinking water use.

© The Author(s) 2023

M. Setiyo et al. (eds.), *Proceedings of the 4th Borobudur International Symposium on Science and Technology 2022 (BIS-STE 2022)*, Advances in Engineering Research 225,

https://doi.org/10.2991/978-94-6463-284-2_17

Solar energy water distillation is a simple technology that can be applied in remote areas to obtain drinking water from polluted water. As a country in the tropics, Indonesia has the potential for solar energy, which can be utilized to purify contaminated water using solar energy water distillation. There are many solar energy water distillation types, including the wick type solar energy water distillation (Fig. 1). Wick-type solar energy water distillation consists of a distillation box and a cover glass. Inside the distillation box is a black cloth that functions as an absorber of solar energy. Contaminated water from the dirty water tank flows into the distillation box. Water flows from the top of the distillation box to the bottom of the distillation box due to the inclined position of the distillation box. A faucet generally regulates the flow rate of water entering the distillation box. Inside the distillation box, water flows in an absorber made of black cloth. The fabric has good capillary properties, allowing water to flow evenly in the absorber. The incoming solar energy enters the distillation box through the glass and is absorbed by the absorber. Solar energy absorbed by the absorber will raise the temperature of the water flowing in the absorber so that the water evaporates. In the process of evaporating water flowing in the absorber, the contaminants in the water do not evaporate. Water vapor will move to the surface of the inner cover glass as more vapor collects on the inner surface of the cover glass, and the partial pressure of the vapor increases. When the partial pressure of the vapor on the inner surface of the cover glass reaches the condensing pressure at the glass temperature, the condensation process occurs on the inner surface of the cover glass. Dew will flow to the bottom due to the tilted position of the cover glass. At the bottom, the dew will flow through the gutter into the distilled water bath. Distilled water is water that does not contain substances that are detrimental to health, so it is suitable for use as drinking water.

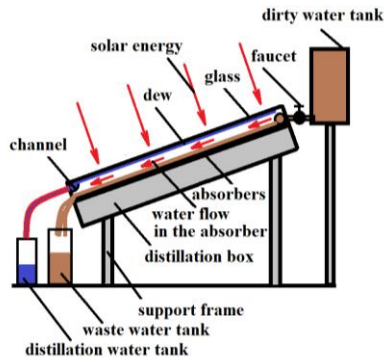

Fig. 1. Wick-type solar energy water distillation

The problem with drinking water purification using solar energy water distillation to date is the low efficiency of solar energy water distillation. Many factors cause the low efficiency of solar energy water distillation. In the distillation of wick-type solar energy water, one of the factors driving the low efficiency is that not all of the contaminated water that enters the distillation apparatus can evaporate. Water that does not evaporate will come out of the distillation apparatus and is called wastewater. The wastewater

receives solar energy from the absorber, so the temperature is relatively high. Waste water will be more and more if the rate of flow of water into the distillation equipment is more significant. The more wastewater, the lower the distillation efficiency. Research to increase the efficiency of solar energy water distillation is still being carried out today. Research on absorber materials for solar energy water distillation of cloth types aims to obtain cloth absorber materials that can increase efficiency [1]. Research to determine the effect of flow rate on the efficiency of distillation of solar energy water was carried out on inclined-type solar energy water distillation using multilevel absorbers [2]. Research on the distillation efficiency of inclined-type solar energy water was carried out by combining several modifications, such as multilevel plates and iron nets. The study used several absorber fabrics, such as sponge polyester, water coral fleece, and tissue [3]. Research on the distillation of solar energy water with multilevel absorbers was carried out to determine the effect of the tilt angle of the absorber on efficiency [4]. Research on the factors that affect efficiency shows that using fins can increase the distillation area so that the temperature of the absorber and the distilled water increases [5]. In addition to adding fins, reflectors, gravel, and external condensers can increase distillation efficiency [6].

One of the factors affecting the distillation efficiency of wick-type solar energy water distillation is the flow rate of contaminated water entering the distillation apparatus. Distillation efficiency will be maximized when the water flow rate into the distillation apparatus is the same as the rate of evaporation in the distillation apparatus. The control method commonly used to regulate the water flow rate entering the distillation apparatus is a faucet. We are adjusting the inlet water flow rate with a faucet to get the same inlet water flow rate, as the evaporation rate is complicated. This research will propose a new flow rate control method different from the existing one, with the principle of a connected vessel. This study aims to analyze the effect of the water flow rate control using the principle of a connected vessel on distillation efficiency.

2 Method

2.1 Distillation Model Specifications

This research was carried out experimentally using a wick-type solar energy water distillation model (Fig. 2). The distillation model consists of (1) an absorber, (2) distilled water tank, (3) an inner channel, (4) frame supports, (5) glass, (6) an outer channel, (7) waste water tank, (8) peristaltic pump and (9) infrared lamp. The slope of the distillation model is 15 degrees, the absorber area of the distillation model used is 0.5 m², and the distillation model cover glass has a thickness of 3 mm. The absorber used in this study is made of cotton. Cotton is a material commonly used in solar energy water distillation. Other absorber materials are bamboo cotton, jute and wool.[7]Data were collected indoors using six infrared lamps as a solar energy simulator, producing heat radiation of 510 W/m². The inlet water flow rate was varied by 3.6, 4.8, and 7.6 litres/hour. Data collection for each variation is for 120 minutes and is recorded every 10 seconds using the sensor.

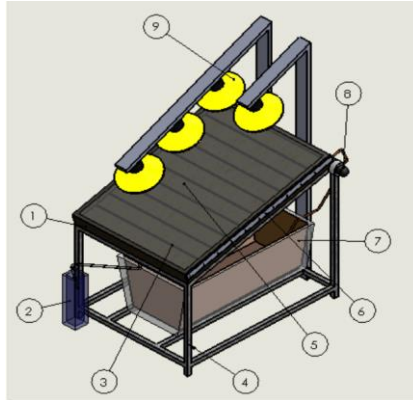
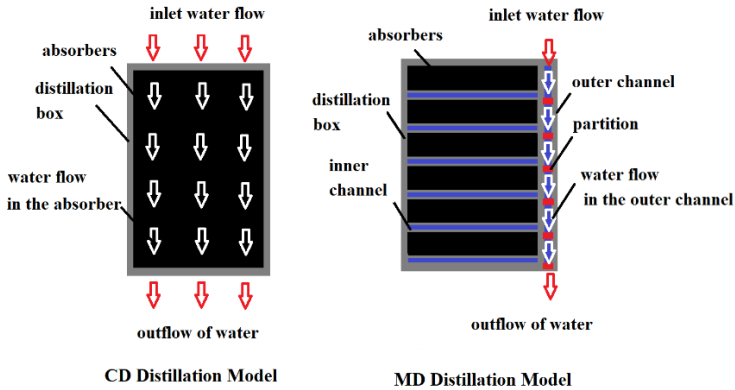

Fig. 2. Wick-type solar energy water distillation model

This study uses two types of solar energy water distillation models: conventional distillation (CD) and modified (MD). CD distillation is distillation by setting the incoming water using a faucet. In other words, CD distillation is a commonly used solar energy water distillation. MD distillation is solar energy water distillation by controlling incoming water using the principle of a connected vessel. In other words, MD distillation is the solar energy water distillation under study. CD distillation compares how much efficiency gain is produced by MD distillation.

Fig. 3a shows the difference in inlet water flow rate in CD and MD distillation. In CD distillation, contaminated water enters the absorber directly. The faucet regulates the flow rate of contaminated water entering the absorber. At the entrance, a spray is used to distribute the water entering the absorber. After entering, the contaminated water will flow to the bottom of the distillation because of the tilted position of the distillation apparatus. As long as it flows on the surface of the contaminated water absorber gets solar energy from the absorber by convection so that the contaminated water temperature increases. Some of the contaminated water will evaporate and condense on the inner surface of the glass, but some cannot evaporate and exit the distillation apparatus as hot wastewater. In the MD distillation model, contaminated water does not directly enter the absorber. Instead, contaminated water will flow in the outer channel, which is located on the side of the distillation box. Some of the water in the outer channel will enter the inner channel, which is in the distillation box. Contaminated water in the inner channel will flow to the absorber surface due to the absorber's capillary nature and evaporates. As long as the water on the surface of the absorber cloth has not evaporated, the water flowing in the outer channel cannot enter the inner channel.



(a)

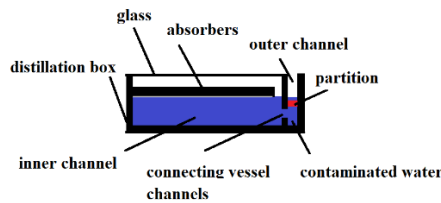

(b)

Fig. 3. Differences in inlet water flow in the CD and MD distillation models

Fig. 3b explains why the water in the outer channel cannot enter the inner channel if the water on the surface of the absorber has not evaporated. Initially, the inner channel (Fig. 3b) was empty because it had yet to be filled with contaminated water. Contaminated water that flows in the outer channel will enter the inner channel through a connected vessel channel at the bottom of the outer channel (Fig. 3b). Water from the outer channel will continue to enter the inner channel until the surface of the inner channel has the same height level as the outer channel. As long as the water level in the outer channel is the same as in the inner channel, water cannot enter the inner channel. Contaminated water will continue to flow in the outer channel to the bottom of the distillation apparatus and exit the outer channel as wastewater. Wastewater in the MD distillation model does not flow on the absorber surface, so it does not take the solar energy received by the absorber; therefore, the wastewater temperature in the MD distillation model remains low.

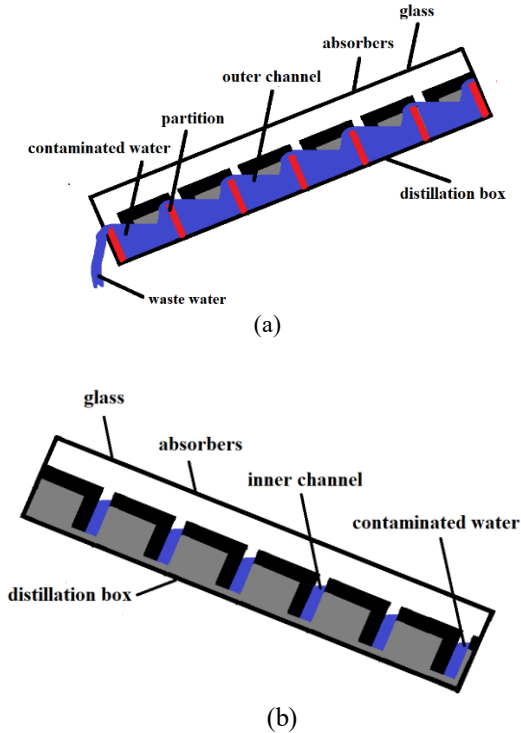

Fig. 4. (a) Outer channel and (b) Inner channel in the MD distillation model

Fig. 4a shows the outer channel in the MD distillation model. The outer channel is located beside the outside of the distillation apparatus. There is a partition on the outer channel regulating the water level in the outer and inner channels. However, the water level in the outer channel will always be the same as that in the inner channel because the outer channel and the inner channel are connected by a connecting vessel located at the bottom of the outer channel. In other words, the outer and inner channels are connected, such as connecting vessels.

Fig. 4b shows the inner channel located inside the distillation box. In the inner channel, contaminated water originates from the outer channel. In addition to contaminated water in the inner channel, there is also a cloth absorber section so that the cloth absorber section contained in the inner channel will be submerged in contaminated water. The existence of the absorber cloth in the inner channel causes contaminated water to flow to the upper surface of the absorber cloth based on the capillarity principle. When the water on the upper surface of the absorber cloth evaporates, the contaminated water in the inner channel will flow to the upper surface of the absorber cloth. The water in the inner channel flowing to the upper surface of the absorber cloth causes the water level in the inner channel to drop and become lower than the water level in the outer channel. The water level in the inner channel, which is lower than the water level in the outer channel, causes the water in the outer channel to flow into the inner channel until

the water level in the outer channel and the inner channel becomes equal again. This water flow process will continue during the distillation process.

2.2 Data Analysis

The two main processes in the distillation of solar energy water are the evaporation and condensation processes. Evaporation or vapor transfer from the surface of the absorber to the inner surface of the cover glass in wick-type solar energy water distillation occurs by convection. Transfer of vapor by convection from the absorber to the inner surface of the cover glass can occur due to the temperature difference between the absorber temperature T_a (OC) and the cover glass temperature T_C (OC), which can be calculated by Equation 1 [8].

$$\Delta T = T_a - T_C \quad (1)$$

The more significant the temperature difference between the absorber and the glass, the faster the vapor formed on the surface of the absorber moves to the inner surface of the glass cover. Conversely, if the temperature difference between the absorber and the glass is negative, the vapor formed on the surface of the absorber will not move to the inner surface of the glass cover.

In the solar energy water distillation process, not all the water flowing in the absorber can evaporate. Water that does not evaporate in the distillation process is generally called wastewater. Wastewater will come out of the distillation box and be accommodated in the waste water tank. The wastewater temperature is generally relatively high because it receives solar energy when it flows in the absorber. Solar energy in wastewater is solar energy that cannot be utilized for evaporation, which means it cannot be used for the distillation process either. The amount of solar energy in wastewater is the energy loss experienced in the distillation process of wick-type solar energy water distillation. The heat energy loss, q_l (W), caused by the presence of wastewater can be calculated by Equation 2 [8].

$$q_l = m_l \cdot C_p \cdot (T_{water\ in} - T_{water\ out}) \quad (2)$$

Where m_l is the mass rate of wastewater (kg/sec), C_p is the heat capacity of water (J/(kg.K)), inlet water is the temperature of the contaminated water entering the distillation box (OC), and exhaust water is the temperature of the wastewater leaving the distillation box (OC).

The energy loss caused by wastewater causes the distillation efficiency of wick-type solar energy water distillation to be low. Therefore, the efficiency of solar energy water distillation is defined as the ratio between solar energy that can be utilized for water evaporation compared to the total amount of solar energy received [8]

$$\eta = \frac{m \cdot h_{fg}}{A_c \cdot \int_0^t G \cdot dt} \quad (3)$$

Where m is the mass of the vaporized water (kg), h_{fg} is the latent heat of evaporation of water (J/kg), A_c is the area of the absorber (m^2), G is the incoming solar energy (W/m^2), and t is the distillation process time (second).

3 Result and Discussion

Fig. 5 shows the water distillation efficiency produced by the CD and MD distillation models for all variations of the inlet water flow rate. In the CD distillation model, the efficiency decreases as the inlet water flow increases; this is due to the more significant the inlet water flow rate, the greater the heat loss that occurs. The more significant heat loss is due to the increasing amount of wastewater at the greater inlet water flow rate. In the MD distillation model, the greater the inlet water flow rate does not affect the resulting efficiency. In the MD distillation model, the incoming water does not flow directly into the absorber, so there is little heat loss. The most significant increase in the efficiency of the MD distillation model over the CD distillation model resulted in a variation of the inlet water flow rate of 4.8 liters/hour, which is 61%.

The results of this study indicate that adjusting the inlet water flow rate using the connected vessel principle can significantly increase efficiency. Several other studies have used different methods to minimize the flow rate of water or the mass of water to be evaporated at one time, such as using a wick equipped with a pin which increases efficiency by more than 23% [9]. Using sand-filled cotton bags can increase efficiency by 31.31% [10]. Basin-type distillation research uses a wicked pile of jute cloth and can increase efficiency by 29.37% [11]. Another study using a simple and inexpensive method, namely porous fins made up of blackened old cotton rags, resulted in an efficiency increase of up to 56% [12]. In addition to the flow rate of water or the mass of water that will be evaporated at one time, several factors that affect efficiency are sensible energy materials [13] and the use of fins, thermal energy storage medium, and an external condenser [14,15]

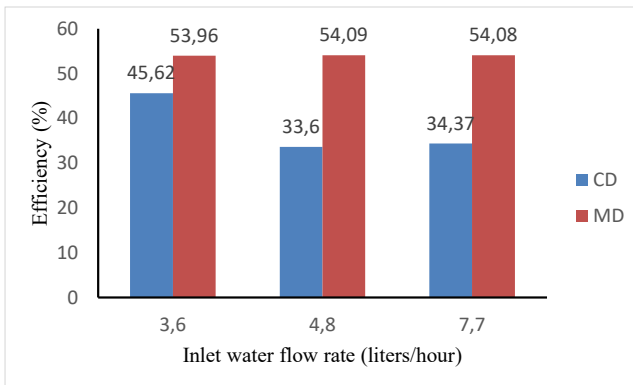

Fig. 5. Efficiency at all variations of the inlet water flow rate

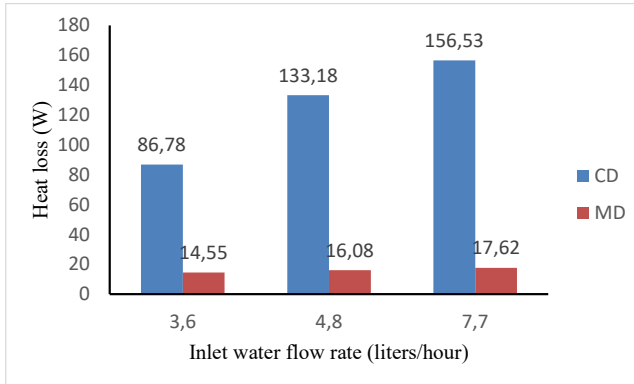

Fig. 6. Heat loss at all variations in the inlet water flow rate

Fig. 6 shows the heat loss of the CD and MD distillation models at all variations of the inlet water flow rate. In the CD distillation model, the more significant the inlet water flow rate, the greater the heat loss. Even though the inlet water in the MD distillation model does not flow directly into the absorber, heat losses also occur in the MD distillation model. However, the heat loss in the MD distillation model is much smaller than that in the CD distillation model, which is only around 11%-17% of the heat loss in the CD distillation model. Heat loss in the MD distillation model occurs due to convection heat transfer from the water in the inner channel to the water in the outer channel.

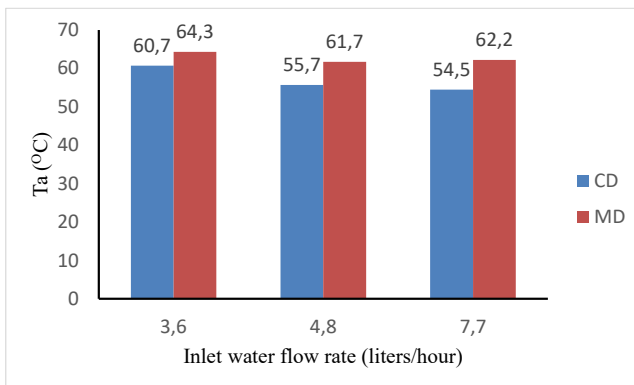

Fig. 7. Absorber temperature at all variations of the inlet water flow rate

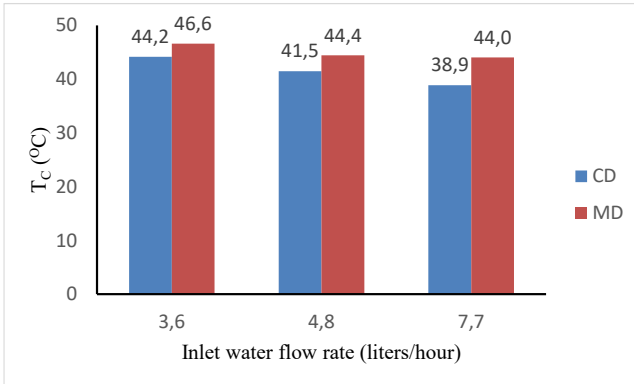

Fig. 8. Glass temperature at all variations of inlet water flow rate

The heat loss that occurs causes a decrease in the temperature of the absorber (Fig. 7). In the CD distillation model, the absorber temperature is lower at the greater inlet water flow rate. In the MD distillation model, the greater flow rate of inlet water also causes a decrease in the absorber temperature, but the decrease in absorber temperature is not too significant. The absorber temperature of the MD distillation model is 6%-14% greater than the absorber temperature of the CD distillation model. The higher absorber temperature causes the water evaporation process of the MD distillation model to be better than the evaporation process of the CD distillation model. A better evaporation process will cause condensing of water vapor on the inner glass surface better. The water vapor will release heat on the inner glass surface during condensation. Therefore the more water vapor that condenses, the higher the surface temperature of the glass.

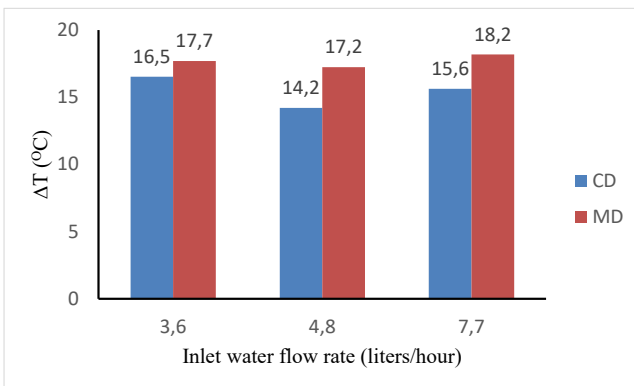

Fig. 9. The difference between the absorber and the glass temperature for all variations of the inlet water flow rate

The glass temperature was higher in the MD distillation model than in the CD distillation model at all variations in the inlet water flow rate (Fig. 8), indicating that the

MD distillation model condensed process was better than the CD distillation model condensation. At all variations of the inlet water flow rate, the glass temperature for the MD distillation model was 5%-13% higher than the glass temperature for the CD distillation model. The difference between the absorber and the glass temperature in the MD distillation model is 7%-16% greater than that between the absorber and the glass temperature in the CD distillation model (Fig. 9). The temperature difference between the absorber and the glass temperature affects the vapor transfer from the absorber to the cover glass. The more significant the temperature difference between the absorber and the glass temperature, the better the vapor transfer from the absorber's surface to the glass's inner surface.

4 Conclusion

From the analysis, the highest efficiency increases of 61% was obtained at a variation of the inlet water flow rate of 4.8 liters/hour. Therefore, the method of controlling incoming water flow rate using the principle of communicating vessels can be used to increase the production of distilled water to meet the need for potable water, especially for people in remote areas.

References

1. T. Karthick Munisamy, A. Mohan, and M. Veeramanikandan, "Experimental investigation of tilted wick solar still using fabrics," *Australian Journal of Mechanical Engineering*, vol. 17, no. 3, pp. 185–190, Sep. 2019, doi: 10.1080/14484846.2017.1334306.
2. F. Farshchi Tabrizi, M. Dashtban, H. Moghaddam, and K. Razzaghi, "Effect of water flow rate on internal heat and mass transfer and daily productivity of a weir-type cascade solar still," *Desalination*, vol. 260, no. 1–3, pp. 239–247, Sep. 2010, doi: 10.1016/j.desal.2010.03.037.
3. M. S. S. Abujazar, S. Fatimah, E. R. Lotfy, A. E. Kabeel, and S. Sharil, "Performance evaluation of inclined copper-stepped solar still in a wet tropical climate," *Desalination*, vol. 425, pp. 94–103, Jan. 2018, doi: 10.1016/j.desal.2017.10.022.
4. H. R. Goshayeshi and M. R. Safaei, "Effect of absorber plate surface shape and glass cover inclination angle on the performance of a passive solar still," *Int J Numer Methods Heat Fluid Flow*, vol. 30, no. 6, pp. 3183–3198, May 2020, doi: 10.1108/HFF-01-2019-0018.
5. I. Mohan, S. Yadav, H. Panchal, and S. Brahmabhatt, "A review on solar still: a simple desalination technology to obtain potable water," *International Journal of Ambient Energy*, vol. 40, no. 3, pp. 335–342, Apr. 2019, doi: 10.1080/01430750.2017.1393776.
6. Ali. F. Muftah, K. Sopian, and M. A. Alghoul, "Performance of basin type stepped solar still enhanced with superior design concepts," *Desalination*, vol. 435, pp. 198–209, Jun. 2018, doi: 10.1016/j.desal.2017.07.017.
7. M. Bhargva and A. Yadav, "Experimental investigation of single slope solar still using different wick materials: a comparative study," *J Phys Conf Ser*, vol. 1276, no. 1, p. 012042, Aug. 2019, doi: 10.1088/1742-6596/1276/1/012042.
8. Ted J. Jansen, *Solar Engineering Technology*. Prentice Hall, 1985.

9. W. M. Alaian, E. A. Elnegiry, and A. M. Hamed, "Experimental investigation on the performance of solar still augmented with pin-finned wick," *Desalination*, vol. 379, pp. 10–15, Feb. 2016, doi: 10.1016/j.desal.2015.10.010.
10. P. Dumka, A. Sharma, Y. Kushwah, A. S. Raghav, and D. R. Mishra, "Performance evaluation of single slope solar still augmented with sand-filled cotton bags," *J Energy Storage*, vol. 25, p. 100888, Oct. 2019, doi: 10.1016/j.est.2019.100888.
11. K. V. Modi and J. G. Modi, "Influence of wick pile of jute cloth on distillate yield of double-basin single-slope solar still: Theoretical and experimental study," *Solar Energy*, vol. 205, pp. 512–530, Jul. 2020, doi: 10.1016/j.solener.2020.05.086.
12. P. K. Srivastava and S. K. Agrawal, "Winter and summer performance of single sloped basin type solar still integrated with extended porous fins," *Desalination*, vol. 319, pp. 73–78, Jun. 2013, doi: 10.1016/j.desal.2013.03.030.
13. A. E. Kabeel, S. A. El-Agouz, R. Sathyamurthy, and T. Arunkumar, "Augmenting the productivity of solar still using jute cloth knitted with sand heat energy storage," *Desalination*, vol. 443, pp. 122–129, Oct. 2018, doi: 10.1016/j.desal.2018.05.026.
14. S. S. Tuly, M. R. I. Sarker, B. K. Das, and M. S. Rahman, "Effects of design and operational parameters on the performance of a solar distillation system: A comprehensive review," *Groundw Sustain Dev*, vol. 14, p. 100599, Aug. 2021, doi: 10.1016/j.gsd.2021.100599.
15. S. S. Tuly, M. S. Rahman, M. R. I. Sarker, and R. A. Beg, "Combined influence of fin, phase change material, wick, and external condenser on the thermal performance of a double slope solar still," *J Clean Prod*, vol. 287, p. 125458, Mar. 2021, doi: 10.1016/j.jclepro.2020.125458.

Open Access This chapter is licensed under the terms of the Creative Commons Attribution-NonCommercial 4.0 International License (<http://creativecommons.org/licenses/by-nc/4.0/>), which permits any noncommercial use, sharing, adaptation, distribution and reproduction in any medium or format, as long as you give appropriate credit to the original author(s) and the source, provide a link to the Creative Commons license and indicate if changes were made.

The images or other third party material in this chapter are included in the chapter's Creative Commons license, unless indicated otherwise in a credit line to the material. If material is not included in the chapter's Creative Commons license and your intended use is not permitted by statutory regulation or exceeds the permitted use, you will need to obtain permission directly from the copyright holder.





Certificate

To certify that :

FA. Rusdi Sambada, I Gusti Ketut Puja

has contributed as

Presenter

in The 4th Borobudur International Symposium 2022
"The Innovation Chain: A Contribution to Society and Industry"

Rector
of Universitas Muhammadiyah Magelang



Dr. Lilik Andriyani, SE., M.Si

Chairman of 4th BIS 2022



Prof. Dr. Muji Setiyo, ST., MT.

Organized by : Co-host:



December 21st, 2022
Magelang, Central of Java, Indonesia

