



The effect of intermittent drying with variable resting times on quality parameters of corn obtained after storage

Geraldo Acácio Mabasso^{a,*},¹ Valdeiney Cambuy Siqueira^b, Osvaldo Resende^a, Wellytton Darci Quequeto^a, Vanderleia Schoeninger^b, Maria Lúcia Ferreira Simeone^c, Elton Aparecido Siqueira Martins^b, Diogo Santos Crippa^b

^a Federal Institute of Education, Science and Technology Goiano (IF Goiano), Rio Verde, GO, Brazil

^b Federal University of Grande Dourados (UFGD), Dourados, MS, Brazil

^c Brazilian Agricultural Research Corporation (Embrapa), Sete Lagoas, MG, Brazil

ARTICLE INFO

Keywords:

Continuous and intermittent drying
Proximate composition
Zea mays L.
Scanning electron microscopy

ABSTRACT

This study aimed to assess the effect of continuous and intermittent drying with different rest times on the quality parameters of stored corn grains. The grains were collected at a moisture content of 25.37 g/100 g and subjected to drying at a temperature of 373 K and air flow rate of 1.5 m³/(min m²). Drying was carried out using five different rest times (0, 4, 8, 12 and 16 h) and continued until the grains reached a final moisture content of 14 ± 0.3 g/100 g. After drying, the grains were stored under laboratory conditions and assessed at 0, 90, 180 and 270 d. The following conclusions were reached: the rest technique reduced grain damage after drying and during storage without substantially compromising proximate composition; longer rest times resulted in darker grains, while storage decreased the hue and increased the colour intensity of grains. Storage diminished the positive effect of intermittent drying on the arrangement, size and agglomeration of starch granules.

1. Introduction

Corn is one of the most widely produced cereals worldwide and a major source of nutrients in developing countries, with around 85% of the corn produced used in livestock production (Garcia-Lara & Serna-Saldivar, 2019). After harvesting, grains are subject to processes that can lead to rapid deterioration, making appropriate postharvest planning essential in preventing possible damage during handling and storage. Eliminating excess water is a decisive factor in grain conservation (Shirmohammadi, Charrault, & Blencowe, 2018).

Artificial drying enables the elimination of excess water and early harvesting but should be a controlled process in order to preserve the quality of agricultural products. Intermittent drying has been used to minimize possible damage such as cracks and breaks on the grain surface in rice, wheat, soybean, coffee and corn (Rufino-Franco & Lima, 2016). Damage declines due to the redistribution of water across the entire surface of the grain during rest, thereby decreasing the moisture gradient generated during desorption (Allaf et al., 2014; Zhang & Litchfield, 1991).

Several authors have used intermittent drying to evaluate aspects related to quality, specific energy consumption and energy efficiency in different products, such as coffee (Borém et al., 2013), rice (Assar, Golmohammadi, Rajabi-Hamaneh, & Hassankiadeh, 2016; Foughi-Dahr, Golmohammadi, Pourjamshidian, Rajabi-Hamaneh, & Hashemi, 2014; Franco, Lima, Farias, & Silva, 2019), soybean (Park, Han, & Yoon, 2018) and corn (Mabasso et al., 2021; Vergara, Capilheira, Gadotti, & Villela, 2018; Wang & Wang, 2019; Zhao et al., 2018).

The change in the quality of agricultural products during drying is unavoidable (Kumar, Karim, & Joardder, 2014). Quality traits include colour (Kumar et al., 2014), grain size, enzyme activity, stress crack index, fungal contamination and moisture content. Scanning electron microscopy (SEM) has been used to monitor or assess cell uniformity in different studies, such as those investigating coffee (Borém et al., 2013), and more recently to assess the effect of postharvest processes such as drying (Sharma & Bhardwaj, 2019).

Resting improves the quality of products subjected to drying because it enables water removal and less energy consumption (Mabasso et al., 2021). The longer the rest time, the greater the storage potential of

* Corresponding author.

E-mail address: geral.do@hotmail.com (G.A. Mabasso).

¹ Permanent address: Zambeze University, 7 de Abril block, Regional street 523 - km 5, Chimoio-Manica, Mozambique.

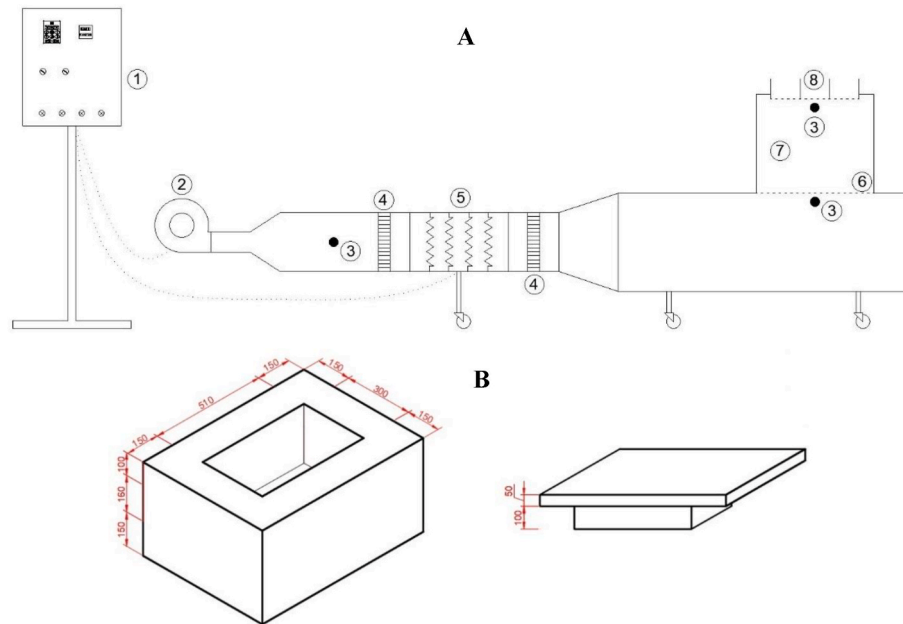

Fig. 1. Experimental fixed-bed dryer used in the drying of corn grains (A) and Characteristics of the expanded polystyrene box used to store the corn during the rest times (B). 1 – temperature and air flow control panel; 2 – centrifugal fan; 3 – temperature measurement point; 4 – air homogenizers; 5 – set of electrical resistances; 6 – perforated screen for thick-bed drying; 7 – thick-bed drying bed; 8 – set of trays for thin-bed drying.

grains after drying (Rufino-Franco & Lima, 2016). As such, the present study aimed to assess the effect of intermittent drying with different rest times on proximate composition, colour and cell membrane integrity of corn grains during storage.

2. Material and methods

Corn grains of the *Cargo TL* cultivar were manually harvested and threshed at an initial wet basis (wb) moisture content of 25.37 ± 0.1 g/100 g. Moisture content was determined by the gravimetric method in a forced air oven, in line with American Society of Agricultural and Biological Engineers standards, using three 15 g samples dried at a temperature of 376 ± 1 K for 72 h (ASABE, 2007).

The grains were dried in a fixed-bed experimental dryer at a temperature of 373 K and air flow rate of $1.5 \text{ m}^3/(\text{min m}^2)$. The 5×4 factorial scheme used consisted of five rest times (0, 4, 8, 12 and 16 h, where zero corresponds to continuous drying and the remaining times intermittent, and four storage times (0, 90, 180 and 270 d), with four repetitions.

Air flow was established based on speed (0.02 m/s) and determined using a digital anemometer, placed above the tray of grains to measure the air injected through the grain mass. A grain volume of 0.035 m^3 was used for each drying cycle, conducted in a drying chamber with a perforated 0.283 m^2 base and 0.124 m-deep grain layer (Fig. 1A).

The mass of grains was turned at regular intervals of 10-min to ensure uniform drying. Water loss was monitored using three perforated polyethylene bags containing 100 g of grains, placed randomly in the grain mass.

Drying ended at a moisture content of 14 ± 0.3 g/100 g (wb). For intermittent drying, the process was interrupted at a moisture content of 18 ± 0.2 g/100 g (wb) and resumed after a rest period until reaching the final moisture content. For resting, a completely sealed expanded polystyrene box was used in order to simulate silo conditions, monitored by an HT-4010 digital data logger. The temperature and relative humidity of the intergranular mass were also monitored daily during storage, using another data logger of the same model. The original box had a capacity of 100 L and was adapted to a length, width and height of 0.510, 0.300 and 0.160 m, respectively, reducing its volume to 24.48 L

($24.48 \times 10^{-3} \text{ m}^3$) (Fig. 1B).

Shortening all the sides resulted in a thickness of 0.150 m, equivalent to a grain mass thickness of 1.011 m considering the thermal conductivity of the expanded polystyrene (0.024 W/(m K) and the grains at a resting temperature and moisture content (0.1618 W/(m K)) (Leila et al., 2019).

After drying, the corn grains were stored in 20 L metal containers with perforated lids covered in mesh to allow air circulation and prevent the entry of insects. The stored grains were assessed according to the established storage times.

2.1. Drying rate

The drying rate was determined using Eq. (1), considering the initial and final moisture content at the different intervals during drying.

$$DR = (X_0 - X_i) / (t_i - t_0) \quad (1)$$

Where DR is the drying rate (kg/(kg h)), X_0 the previous moisture content (decimal, dry basis - db), X_i the current moisture content (decimal, db), t_i the current total drying time (h), and t_0 the previous total drying time (h).

2.2. Iodine test

The iodine test was adapted based on the methodology described by Cícero and Silva (2003), establishing a soaking time of 25 min for the corn grains to observe any damage resulting from the drying process.

Four repetitions and two 100-grain samples were used for each treatment. The samples were placed in disposable 100 mL plastic cups, added with a 4 mL/100 mL iodine solution that completely covered the grains. After soaking, the grains were washed under running water and dried with paper towel. The grains were then counted considering purple coloring a positive result for iodine reaction with starch, and the presence of visible cracks. The final result was expressed as a percentage.

2.3. Proximate composition of corn grains after drying

Dry matter, carbohydrate, protein, ash, raw fiber and ether extract

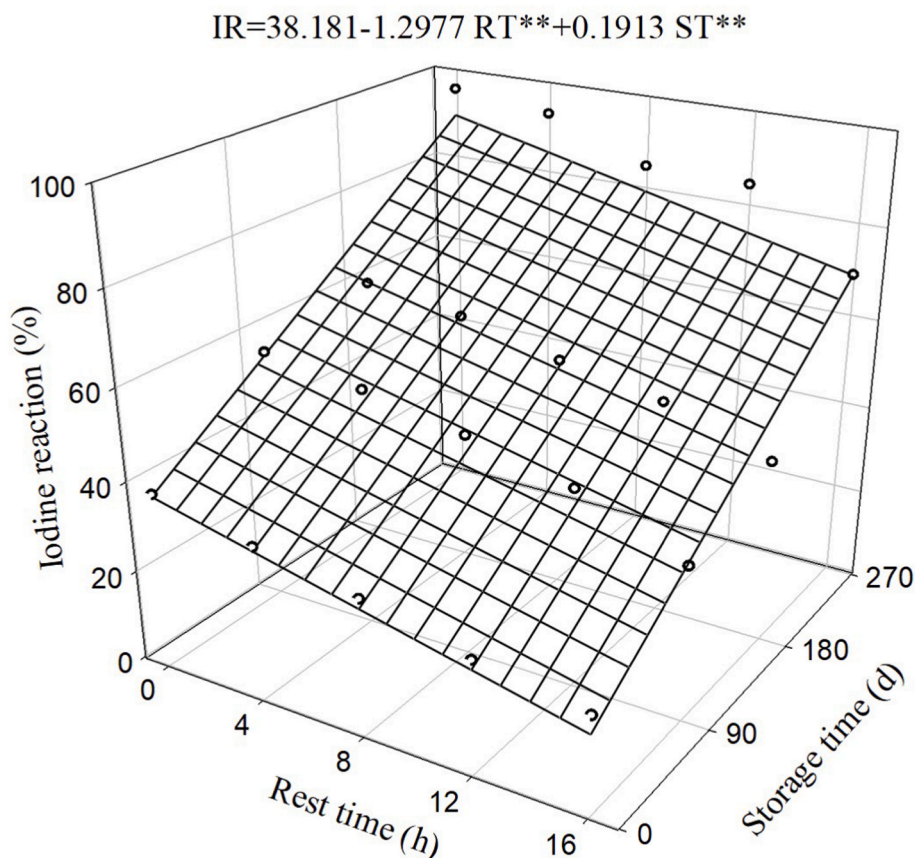

Fig. 2. Reaction with iodine in corn grains after drying and during storage as a function of different rest times. **Significant effect according to the F-test ($P < 0.01$).

content were determined for each treatment in three samples per repetition. The samples were previously ground in a Solab SL Wiley mill, set to a particle size of 1 mm.

After grinding, they were subjected to near infrared spectroscopy (NIRS) in a Buchi NIRFlex N-500 spectrometer (Buchi Laborotechnik, Flawil, Switzerland) equipped with an InGaAs detector. The samples were placed in a borosilicate glass Petri dish for reading. The spectra were obtained in the 4000 to 10,000/cm region at a resolution of 4/cm and 32 scans per spectrum. Based on the principle of electromagnetic radiation, NIRS exhibits good accuracy and high precision and by applying mathematics to analytical chemistry, determines precise values according to curves calibrated as a function of the material analyzed.

Dry matter, protein, ash, raw fiber and ether extract content were obtained by direct measurement and carbohydrate content was deduced as the remaining value after the sum of the other variables.

2.4. Colour assessment

Grain colour was assessed using the HunterLab system by analyzing the L^* , a^* and b^* coordinates, where L^* is lightness and corresponds to the range from black ($L^* = 0$) to white ($L^* = 100$); a^* the red/green coordinate and b^* the blue/yellow coordinate.

Readings were performed using a Konica Minolta® CR-410 chroma meter, with a 50 mm aperture. The device was previously calibrated at the D65 setting ($Y = 93.58$; $x = 0.3169$ and $y = 0.3334$), which represents the average daily light. Three readings were performed for each repetition, with the grains in Petri dishes against a white background.

After the chromaticity coordinates were analyzed, Chroma (C^*) (Eq. (2)) and the Hue angle (H^*) (Eq. (3)) were calculated. Chroma (C^*) indicates color saturation or intensity and the Hue angle (H^*) the observable color (hue) by converting the a^* and b^* coordinates.

$$C^* = \sqrt{(a^*)^2 + (b^*)^2} \quad (2)$$

$$H^* = \arctan(b^* / a^*) \quad (3)$$

Where C^* is colour chromaticity (Chroma) or saturation, H^* the hue angle ($^\circ$), a^* the red/green coordinate and b^* the blue/yellow coordinate.

2.5. Scanning electron microscopy of corn flour

Scanning electron microscopy (SM) was carried out immediately after drying and again at 270 d of storage. The corn grains were ground in a Fortnox Star FT 60 Wiley mill with a 2 mm mesh sieve and the resulting flour was dried in a forced air oven at 338 ± 1 K until constant mass. Next, the samples were distributed on copper tape to improve electron scattering and placed on the microscope for image capturing at different resolutions. A Hitachi 3000 scanning electron microscope was used to observe particle uniformity at 1200X magnification.

2.6. Statistical analysis

The data are represented in form of mean \pm standard deviation. The comparison was determined by t -test and linear regression according to the result of analysis of variance (ANOVA) at 5% of significance. Pearson's correlation were also performed, using the Student's t -test at 5% of significance for proximate composition parameters.

3. Results and discussion

The effective drying time of the corn grains declined under intermittent drying. Although this decline was more marked for the two

Table 1

Proximate composition (db) of corn grains as a function of storage time after continuous and intermittent drying with different rest times. Different capital letters in row indicate significant differences at $t < 0.01$.

Rest time (h)	Proteins (g/100 g)		Raw fiber (g/100 g)	
	Storage time (d)		Storage time (d)	
	0	270	0	270
0	9.135 ± 0.108 B	9.444 ± 0.116 A	1.170 ± 0.201 A	1.041 ± 0.265 A
4	9.060 ± 0.249 A	8.786 ± 0.140 B	0.977 ± 0.116 A	0.376 ± 0.145 B
8	9.301 ± 0.140 A	9.383 ± 0.104 A	1.106 ± 0.066 A	0.476 ± 0.167 B
12	9.170 ± 0.232 A	9.325 ± 0.066 A	0.903 ± 0.088 A	0.238 ± 0.138 B
16	8.951 ± 0.259 A	9.174 ± 0.077 A	0.962 ± 0.108 A	0.570 ± 0.182 B
	Ash (g/100 g)		Carbohydrates (g/100 g)	
0	1.306 ± 0.172 B	1.747 ± 0.134 A	83.500 ± 0.456 A	82.876 ± 0.358 B
4	1.554 ± 0.088 A	1.336 ± 0.155 B	83.523 ± 0.336 B	84.788 ± 0.751 A
8	1.531 ± 0.097 B	1.812 ± 0.018 A	83.286 ± 0.297 A	83.669 ± 0.190 A
12	1.633 ± 0.069 B	1.888 ± 0.043 A	83.521 ± 0.223 A	84.017 ± 0.258 A
16	1.479 ± 0.099 B	1.948 ± 0.013 A	83.884 ± 0.307 A	83.728 ± 0.059 A
	Dry matter (g/100 g)		Ether extract (g/100 g)	
0	88.093 ± 0.206 B	89.586 ± 0.212 A	4.809 ± 0.129 A	4.675 ± 0.145 B
4	88.544 ± 0.032 A	87.912 ± 0.033 B		
8	88.418 ± 0.033 B	88.725 ± 0.042 A		
12	88.265 ± 0.054 B	88.697 ± 0.023 A		
16	88.060 ± 0.082 B	88.927 ± 0.043 A		

longest rest times, the average drying rates for rest times of 8, 12 and 16 h were similar. The same occurred for continuous drying and intermittent drying with a 4-h rest period, which exhibited similar average drying rates. However, the difference of 0.005 kg/(kg h) was sufficient to contribute to reducing the effective drying time by 0.17 h. Foroughi-Dahr et al. (2014) investigated different drying systems for rice grains and concluded that the drying rate was positively influenced by rest time.

According to Zhang and Litchfield (1991), the effective drying time and drying rate are a function of the temperature, cycles and rest time. Even a single cycle is sufficient to shorten the effective drying time when compared to continuous drying as a result of the higher water removal rate, which is favoured by increased water diffusion from the center to

the surface of the grain, promoting uniform redistribution of water and intergranular temperature (Allaf et al., 2014; Foroughi-Dahr et al., 2014; Lima, Delgado, Neto, & Franco, 2016).

The iodine test provides an indirect assessment of damage to starchy products as a result of postharvest processes such as drying. The rest time during continuous and intermittent corn grain drying showed a significant interaction with storage time (Fig. 2). While increased storage times promoted greater damage, an inverse effect was observed for longer rest periods. Intermittent drying contributed to maintaining cell membrane integrity (Shirmohammadi et al., 2018), reducing cracks and fissures in the grains and, consequently, reducing iodine absorption and reaction.

According to Rufino-Franco and Lima (2016), the longer the rest time, the greater the benefits in terms of physical damage, changes in proximate composition, microbiological activity and infestation by insect pests. As a result, the rest time will be proportionally favourable to greater storage potential for grains after drying (Vergara et al., 2018). Moreover, rest time exerted a greater influence than storage time, with a decrease of 1.29 per rest h and increase of 0.19 per d during storage.

The proximate composition of the corn flour was determined immediately after drying and at 270 d of storage. The moisture content of the flour for rest times of 0, 4, 8, 12 and 16 h was 11.91, 11.46, 11.58, 11.74 and 11.94 g/100 g, respectively, immediately after drying, and 10.41; 12.09; 11.28; 11.30; and 11.07 g/100g following storage. This minor variation is associated with the temperature and relative humidity conditions, and the slight decline in moisture content during grinding.

With the exception of ether extract, formed by heterogeneous composition of lipids and all other non-polar compounds, the results of analysis of variance showed a significant interaction between rest and storage times. However, when analyzed separately, rest periods and storage times exhibited differences for ether extract.

Protein content varied at 270 d of storage for continuous drying and a rest time of 4 h. This indicates a contradictory trend, whereby the longest rest times did not alter the different contents assessed, but no trend was observed for variations in values recorded after drying and at 270 d as a function of rest time, with average values of 9.12 and 9.22 g/100 g before and at the end of storage, respectively (Table 1).

Dry matter, ash, carbohydrate, raw fiber and protein concentrations were similar after drying and at 270 d of storage, with no trend observed in relation to rest time. Fig. 3A demonstrates minimal variation except for fiber content, which declined from 1.024 g/100 g at 0 d of storage to 0.541 g/100 g at 270 d.

Ether extract exhibited a decreasing trend in relation to rest time (Fig. 3B), with the lowest concentration recorded at a storage time of 270 d (Table 1). The variation in the behaviour of the variables can be attributed to the interdependence of the different elements of the composition, that is, an increase in the content of one hamper that of the others. Similar behaviour was observed by Scariot, Karlinski, Dionello,

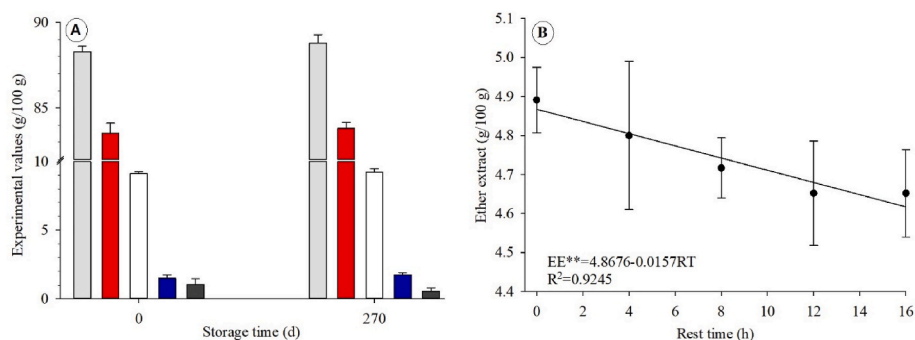

Fig. 3. Average dry matter, carbohydrate, protein, ash and raw fiber content as a function of storage time after continuous and intermittent drying (A) and Variation in ether extract content as a function of rest time after continuous and intermittent drying (B). ■ Dry matter, ■ Carbohydrates, □ Protein, ■ Ash, ■ Raw fiber, IR – Iodine reaction, RT – Rest time, ST – Storage time, EE – Ether extract, RT – Rest time. **Significant effect according to the F-test ($P < 0.01$).

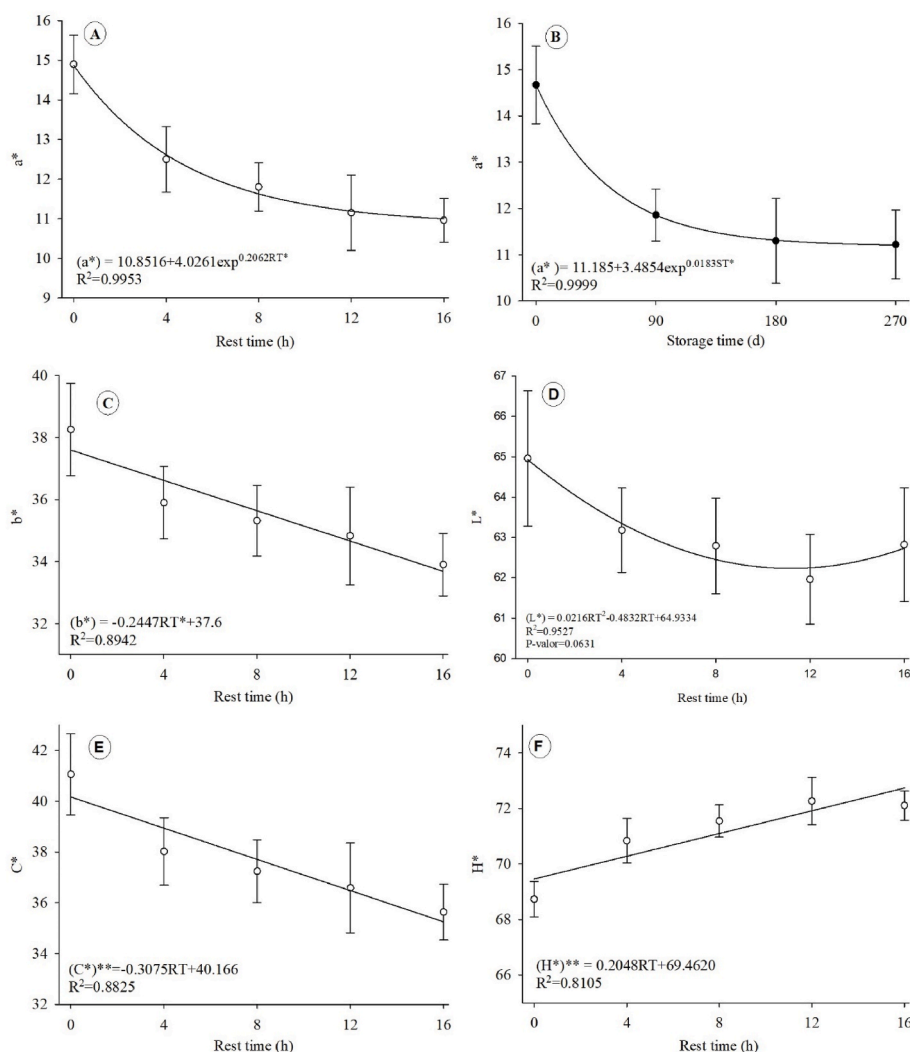

Fig. 4. Average values of a^* (A), b^* (C), L^* (D), C^* (E) and H^* (F) as a function of rest time and a^* (B) as a function of storage times after continuous and intermittent drying. RT – Rest time, ST – Storage time. *Significant effect according to the F-test ($P < 0.05$).

Radünz, and Radünz (2020) in rice grain drying, with a decline in protein and lipid content as storage time increased and, by contrast, a rise in fiber and ash content.

The correlation between components of proximate composition is random, with a strong negative correlation between protein and carbohydrate content ($r = -0.729$), also observed between carbohydrate and raw fiber content ($r = -0.701$). An increase in dry matter content prompted a rise in protein content, whereas carbohydrate content remained independent. It is important to underscore that, proportionally, carbohydrate and protein content contribute more to dry matter, meaning that a significant increase in one tends to affect the other. However, in the present study, the increase in dry matter did not result in significant increases in protein content but accompanied the rise in carbohydrate content.

With regard to colour variation or behaviour, a^* showed a decreasing trend as a function of rest and storage times (Fig. 4A and B), while “ b^* ” and “ L^* ” exhibited similar behaviour as a function of rest time, linear for “ b^* ” and quadratic for “ L^* ” (Fig. 4C and D). There was no variation in these last two parameters during storage, with average values of 35.64 and 63.14 for b^* and L^* , respectively. The sensitivity of corn grains to storage may be associated with differences between genotypes, which convert into differences in the physical and chemical properties of the grains, as well as their nutritional composition that can lead to the degradation of carotenoids (Ortiz, Rocheford, & Ferruzzi, 2016).

However, the effective control of the moisture content, temperature and relative humidity in the granular mass is essential to reduce the speed of the degradative reactions, which convert into colour change as well as the chemical composition of the product.

The variation of b^* are in line with those reported by Saenz, Abdala, Borrás, and Gerde (2020) in which they refer to their reduction for harder corn grain genotypes, a fact that may be associated with greater hardness of corn grains when subjected to intermittent drying with longer resting times (Mabasso, Siqueira, Quequeto, Resende, & Goneli, 2020).

The curves for the three colour parameters showed a darkening trend with longer rest times as a result of the decline in L^* value. Despite this quadratic behaviour, indicating increased lightness between 12 and 16 h of rest, average deviations overlap. Enzymatic darkening of corn grains is associated with the effect of prolonged exposure to heat during drying and rest (Paulsen, Singh, & Singh, 2019), as well as oxidative processes caused by enzymes such as polyphenol oxidase and peroxidase (Oliveira et al., 2010).

Chroma “ C^* ” and the Hue angle “ H^* ” showed no variation during storage, with average values of 37.71 and 71.10° for C^* and “ H^* ”, respectively (Fig. 4E and F). The behaviour of C^* and H^* values demonstrates that although colour intensity increased with longer rest times, the hue of corn grains became lighter. This is in line with the behaviour of L^* , which showed a trend of grain darkening. According to Oliveira

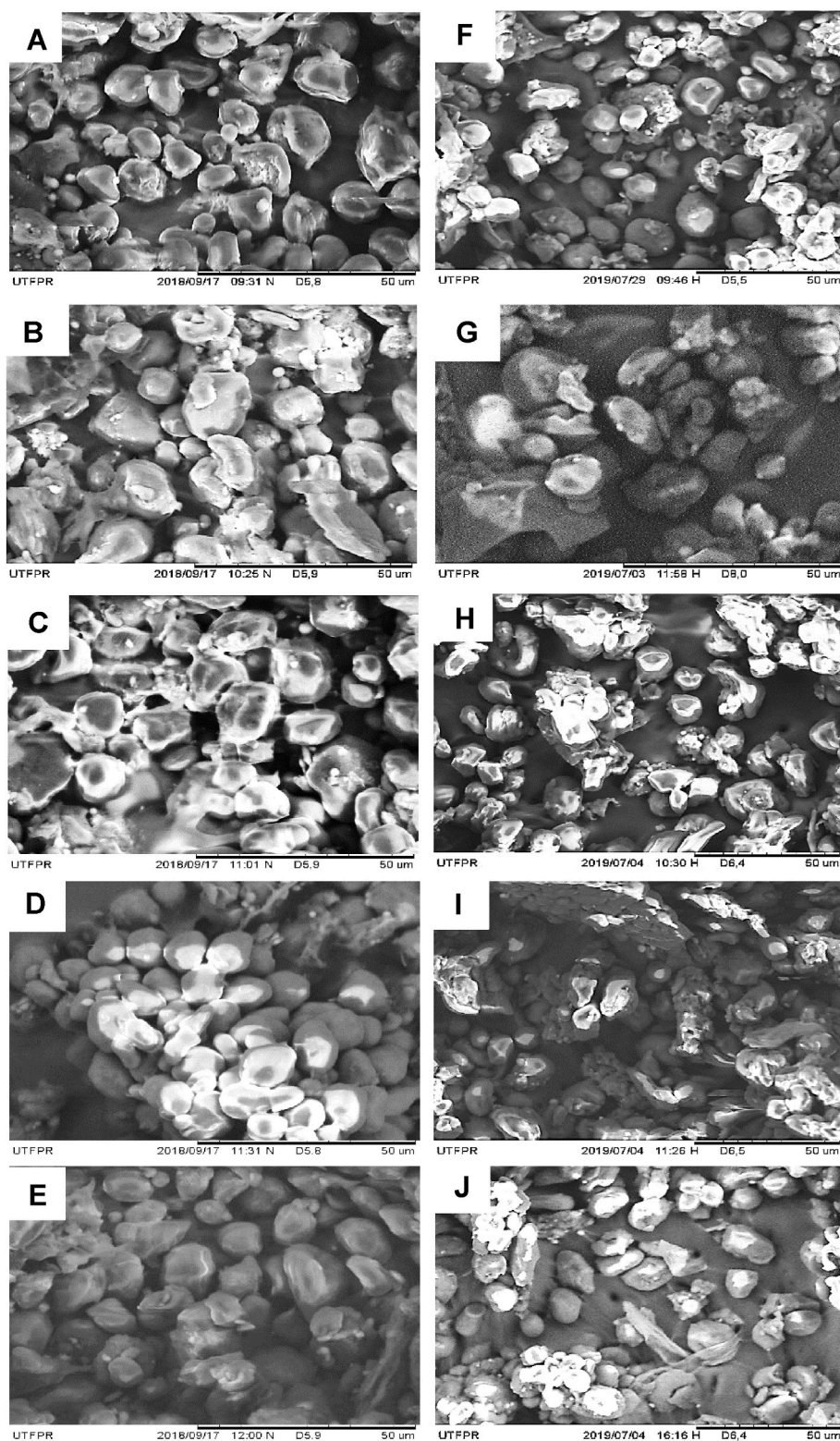

Fig. 5. Scanning electron microscopy of corn flour after continuous and intermittent drying and at 270 d of storage. Images captured at 1200X magnification (50 µm, reduced). A, B, C, D and E – Continuous and intermittent drying with 4, 8, 12 and 16 h of rest immediately after drying. F, G, H, I and J - Continuous and intermittent drying with 4, 8, 12 and 16 h of rest at 270 d of storage.

[et al. \(2010\)](#), drying is a means of inactivating enzymes, with the authors reporting a 33.57% reduction in their concentration during the drying of white oat grains at 373 K. [Lima, Tomé, and Abreu \(2014\)](#) reported that the seed coat of bean grains darkened after six months of storage and that the decline in the L^* coordinate may be the result of increased

polyphenol oxidase associated with peroxidase activity.

Colour is the result of chemical, biochemical, microbiological and physical changes that can occur in the crop and postharvest processes such as drying and storage. Understanding changing colour conditions during these postharvest processes helps optimize the quality of

agricultural products and the conditions of biological processes.

Fig. 5 shows clusters of different-shaped particles in varying arrangements constituting starch granules and dark surfaces corresponding to possible damage or cracks. Thus, the level of cell uniformity can be visualized at both corn flour assessment times. There is a trend in the uniform distribution of starch particles immediately after drying, with greater dispersion and more dark spaces in continuous drying (Fig. 5A). In intermittent drying, particles are more clustered and consequently less dispersed, with fewer dark spaces between particles or clusters (Fig. 5B–E).

In comparative terms, there is no clear trend for particle uniformity at 270 d of storage (Fig. 5F–J), with greater dispersion immediately after drying. In general, particles were relatively smaller and dark spaces between particles or clusters occurred randomly between the different rest times.

SEM has been used to assess the effect of drying in agricultural products such as coffee (Borém et al., 2013), indicating changes in cell membrane structure, with gaps or intracellular voids as a result of different drying methods, and to evaluate quality of corn and wheat (Chakraborty, Pallen, Shetty, Roy, & Mazumder, 2020; Kumar & Khatkar, 2017; Wang & Wang, 2019; Zou, Xu, Tian, & Li, 2019).

According to Allaf et al. (2014), continuous drying increases intergranular temperature, which is not offset by the amount of water removed, resulting in the potential for greater damage to the final product due to the presence of larger voids between particles, in addition to smaller particles and greater dispersion (Fig. 5A and F). Intermittent drying contributed to preserving the quality of the final product and the performance of the drying process, with less specific energy consumption and greater energy efficiency (Allaf et al., 2014; Kumar et al., 2014; Mabasso et al., 2021).

Grains tend to shrink during drying in response to the volume of water lost due to evaporation, reducing their size. Thus, heating significantly increases internal pressure in the grain, with a tendency to expand from the center outward due to water diffusion. The limited expansion and low elastic capacity of grains mean that cracks and fissures are common. Intermittent drying results in less damage, contributing significantly to better-quality grains and improved seed vigour (Lima et al., 2016). However, despite the noteworthy effects of intermittent drying immediately after the process, no influence was observed after 270 d of storage.

4. Conclusions

Resting reduced the degree of damage in corn grains after drying and during storage without effectively interfering in proximate composition. Longer rest times produced darker grains, whereas storage resulted in lighter hues and increased colour intensity. Storage diminished the positive effect of intermittent drying on the better arrangement, size and agglomeration of starch granules. The adoption of different rest times in intermittent drying phases by pressure reduction on the storage unit, at the peak of the harvest, might have potential on quality maintenance in the conservation period of processed corn or better acceptance on expedition.

This technique reduced the negative impact of product deterioration during the storage time, culminating in economic gains for producers and managers of the storage units. In addition, the effect of this technique for different types of commercial corn are important for next research about this topic, even for other grains.

CRedit authorship contribution statement

Geraldo Acácio Mabasso: Conceptualization, Methodology, conducting research, Formal analysis, writing and revising the manuscript. **Valdiney Cambuy Siqueira:** Conceptualization, Methodology, conducting research, Formal analysis, writing and revising the manuscript. **Oswaldo Resende:** Methodology, Writing – review & editing.

Wellyton Darci Quequeto: Conducting research, Formal analysis, revising the manuscript. **Vanderleia Schoeninger:** Methodology, conducting research and revising the manuscript. **Maria Lúcia Ferreira Simeone:** Conducting research. **Elton Aparecido Siqueira Martins:** Methodology, and conducting research. **Diogo Santos Crippa:** Conducting research.

Declaration of competing interest

The authors declare that they have no known competing financial interests or personal relationships that could have appeared to influence the work reported in this paper.

Data availability

Data will be made available on request.

Acknowledgments

To the Scholarship Institute (IBE) of Mozambique for the scholarship awarded to the first author (UFGD), the Federal Institute of Education, Science and Technology Goiano - Rio Verde Campus (IF Goiano), the Laboratory of the Brazilian Agricultural Research Association (Embrapa) for Corn and Sorghum in Sete Lagoas/Minas Gerais state (MG) and the UTFPR Central Analysis Laboratory, Pato Branco Campus.

Appendix A. Supplementary data

Supplementary data to this article can be found online at <https://doi.org/10.1016/j.lwt.2023.114855>.

References

- Allaf, K., Mounir, S., Negm, M., Allaf, T., Ferrasse, H., & Mujumdar, A. (2014). Intermittent drying. *Handbook of industrial drying*, 4, 491–501. <https://doi.org/10.1201/b17208>
- ASABE. (2007). American society of agricultural and biological Engineers. In *Resistance to airflow of grains, seeds, other agricultural products, and perforated metal sheets: ASAE D272.3 MAR1996, R2007. Standards, engineering practices, and data*. St. Joseph (pp. 544–550).
- Assar, M., Golmohammadi, M., Rajabi-Hamaneh, M., & Hassankiadeh, M. N. (2016). A combined experimental and theoretical approach to study temperature and moisture dynamic characteristics of intermittent paddy rice drying. *Chemical Engineering Communications*, 203, 1242–1250. <https://doi.org/10.1080/00986445.2016.1172483>
- Borém, F. M., Oliveira, P. D., Isquierdo, E. P., Giomo, G. S., Saath, R., & Cardoso, R. A. (2013). Scanning electron microscopy of coffee beans subjected to different forms of processing and drying. *Coffee Science*, 8, 227–237. <http://www.coffeescience.ufla.br/index.php/Coffeescience/article/view/420>
- Chakraborty, I., Pallen, S., Shetty, Y., Roy, N., & Mazumder, N. (2020). Advanced microscopy techniques for revealing molecular structure of starch granules. *Biophysical Reviews*, 12, 105–122. <https://doi.org/10.1007/s12551-020-00614-7>
- Cícero, C. M., & Silva, W. R. (2003). Danos Mecânicos Associados a Patógenos e Desempenho de Sementes de Milho. *Bragantia*, 62, 305–314.
- Foroughi-Dahr, M., Golmohammadi, M., Pourjamshidian, R., Rajabi-Hamaneh, M., & Hashemi, S. J. (2014). On the characteristics of thin-layer drying models for intermittent drying of rough rice. *Chemical Engineering Communications*, 202, 1024–1035. <https://doi.org/10.1080/00986445.2014.900049>
- Franco, C. M., Lima, A. G., Farias, V. S., & Silva, W. P. (2019). Modeling and experimentation of continuous and intermittent drying of rough rice grains. *Heat and Mass Transfer*, 56, 1003–1014. <https://doi.org/10.1007/s00231-019-02773-0>
- García-Lara, S., & Serna-Saldivar, S. O. (2019). Corn history and culture. In S. O. Serna-Saldivar (Ed.), *Corn* (pp. 1–18). AACC International Press. <https://doi.org/10.1016/B978-0-12-811971-6.00001-2>
- Kumar, C., Karim, M. A., & Joardder, M. U. H. (2014). Intermittent drying of food products: A critical review. *Journal of Food Engineering*, 121, 48–57. <https://doi.org/10.1016/j.jfoodeng.2013.08.014>
- Kumar, R., & Khatkar, B. S. (2017). Thermal, pasting and morphological properties of starch granules of wheat (*Triticum aestivum* L.) varieties. *Journal of Food Science & Technology*, 54, 2403–2410. <https://doi.org/10.1007/s13197-017-2681-x>
- Leila, A., Jean-Yves, M., Sid-Ahmed, R., Thierry, M., Luc, G., Stephane, C., et al. (2019). Prediction of thermal conductivity and specific heat of native maize starch and comparison with HMT treated starch. *Journal of Renewable Materials*, 7, 535–546. <https://doi.org/10.32604/jrm.2019.04361>
- Lima, A. G. B., Delgado, J. M. P. Q., Neto, S. R. F., & Franco, C. M. R. (2016). Intermittent drying: Fundamentals, modeling and applications. In J. M. P. Q. Delgado, &

- A. G. B. Lima (Eds.), *Drying and energy technologies* (pp. 19–41). Switzerland: Springer International Publishing Switzerland. https://doi.org/10.1007/978-3-319-19767-8_2.
- Lima, R. A. Z., Tomé, L. M., & Abreu, C. M. P. D. (2014). Vacuum package: Its effect on the hardening and darkening of the beans during storage. *Ciência Rural*, *44*, 1664–1670. <https://doi.org/10.1590/0103-8478cr20120832>
- Mabasso, G. A., Siqueira, V. C., Quequeto, W. D., Jordan, R. A., Martins, E. A. S., & Schoeninger, V. (2021). Energy efficiency and physical integrity of maize grains subjected to continuous and intermittent drying. *Brazilian Journal of Agricultural and Environmental Engineering*, *25*, 710–716. <https://doi.org/10.1590/1807-1929/agriambi.v25n10p710-716>
- Mabasso, G. A., Siqueira, V. C., Quequeto, W. D., Resende, O., & Goneli, A. L. D. (2020). Compressive strength of corn kernels subjected to drying under different rest periods. *Revista de Ciências Agronômicas*, *51*, 1–8. <https://doi.org/10.5935/1806-6690.20200075>
- Oliveira, L. D. C., Gutkoski, L. C., Elias, M. C., Mazzutti, S., Aosani, E., & Rocha, J. C. D. (2010). Effect of drying temperature on the quality of white oat grains. *Ciência E Agrotecnologia*, *34*, 313–319. <https://doi.org/10.1590/S1413-70542010000200007>
- Ortiz, D., Rocheford, T., & Ferruzzi, M. G. (2016). Influence of temperature and humidity on the stability of carotenoids in biofortified maize (*Zea mays* L.) genotypes during controlled postharvest storage. *Journal of Agricultural and Food Chemistry*, *64*, 2727–2736. <https://doi.org/10.1021/acs.jafc.5b05698>
- Park, H. W., Han, W. Y., & Yoon, W. B. (2018). Drying characteristics of soybean (*Glycine max*) using continuous drying and intermittent drying. *International Journal of Food Engineering*, *14*, 1–10. <https://doi.org/10.1515/ijfe-2018-0057>
- Paulsen, M. R., Singh, M., & Singh, V. (2019). Measurement and maintenance of corn quality. In S. O. Serna-Saldivar (Ed.), *Corn* (pp. 165–211). AACC International Press. <https://doi.org/10.1016/B978-0-12-811971-6.00007-3>.
- Rufino-Franco, C. M., & Lima, A. G. B. (2016). Intermittent drying of porous materials: A review. *Diffusion Foundations*, *7*, 1–13. <https://doi.org/10.4028/www.scientific.net/DF.7.1>.
- Saenz, E., Abdala, L. J., Borrás, L., & Gerde, J. A. (2020). Maize kernel color depends on the interaction between hardness and carotenoid concentration. *Journal of Cereal Science*, *91*, 1–7. <https://doi.org/10.1016/j.jcs.2019.102901>
- Scariot, M. A., Karlinski, L., Dionello, R. G., Radünz, A. L., & Radünz, L. L. (2020). Effect of drying air temperature and storage on industrial and chemical quality of rice grains. *Journal of Stored Products Research*, *89*, 1–6. <https://doi.org/10.1016/j.jspr.2020.101717>
- Sharma, V., & Bhardwaj, A. (2019). Scanning electron microscopy (SEM) in food quality evaluation. In J. Zhong, & X. Wang (Eds.), *Evaluation technologies for food quality* (pp. 743–761). Woodhead Publishing. <https://doi.org/10.1016/B978-0-12-814217-2.00029-9>.
- Shirmohammadi, M., Charraut, E., & Blencowe, A. (2018). Micromechanical properties of almond kernels with various moisture content levels. *International Journal of Food Properties*, *21*, 1820–1832. <https://doi.org/10.1080/10942912.2018.1508157>
- Vergara, R. D. O., Capilheira, A. F., Gadotti, G. I., & Vilela, F. A. (2018). Intermittence periods in corn seed drying process. *Journal of Seed Science*, *40*, 193–198. <https://doi.org/10.1590/2317-1545v40n2187373>
- Wang, B., & Wang, J. (2019). Mechanical properties of maize kernel horny endosperm, floury endosperm and germ. *International Journal of Food Properties*, *22*, 863–877. <https://doi.org/10.1080/10942912.2019.1614050>
- Zhang, Q., & Litchfield, J. B. (1991). An optimization of intermittent corn drying in a laboratory scale thin layer dryer. *Drying Technology*, *9*, 233–244. <https://doi.org/10.1080/07373939108916672>
- Zhao, Y., Huang, K., Chen, X. F., Wang, F. H., Chen, P. X., Tu, G., et al. (2018). Tempering-drying simulation and experimental analysis of corn kernel. *International Journal of Food Engineering*, *14*, 1–10. <https://doi.org/10.1515/ijfe-2017-0217>
- Zou, J., Xu, M., Tian, J., & Li, B. (2019). Impact of continuous and repeated dry heating treatments on the physicochemical and structural properties of waxy corn starch. *International Journal of Biological Macromolecules*, *135*, 379–385. <https://doi.org/10.1016/j.ijbiomac.2019.05.147>