

# **THEORY AND TECHNOLOGY OF PARTICLE ACCELERATION**

## **DEVELOPMENT OF A PULSE SOLENOID OF MAGNETIC FIELD AMPLITUDE UP TO 0.5 T AND A PULSE SINUSOIDAL CURRENT GENERATOR FOR ITS POWER SUPPLY**

*N.G. Reshetnyak, V.P. Romas'ko, I.A. Chertishev*

*National Science Center "Kharkov Institute of Physics and Technology", Kharkiv, Ukraine*

The magnetic system of the installation to control the transverse dimensions of an electron beam formed by a magnetron gun with a secondary emission cathode was updated. An additional solenoid with pulsed power supply located in a vacuum chamber at a distance of 0.05...0.1 m from the gun's edge will be used in experiments. The solenoid design was selected and calculated. Possibility of a magnetic field generation of amplitude of up to 0.5 T at amplitude of the pulse current of  $\sim 1.5$  kA, was demonstrated. The field has a uniform area at the level of  $\pm 5\%$  over the length of  $\sim 0.2$  m.

PACS: 12.10

### **INTRODUCTION**

Investigations of electron sources with cold cathodes operating in the secondary emission mode placed in crossed electric and magnetic fields are carried out in NSC KIPT. A magnetron gun is used as an electron source on the basis of which an electron accelerator has been created. An axial electron beam to irradiate metal targets [1 - 3] is used in the accelerator. Use of the beam method for material treatment makes it possible to create materials with increased microhardness, corrosion resistance, etc. [2 - 6]. The possibility of irradiating the inner cylindrical surface of samples using a radial electron beam was studied in [7].

To study the possibility of controlling the size of the electron beam it is required to be able to control the magnetic field in a fairly wide range. This will make it possible to irradiate the outer cylindrical surface of metal tubes and cylinders. The possibility of controlling the transverse dimensions of an electron beam using a ring magnet made of NdFeB at a magnetic field strength of  $\sim 0.3$  T was studied in [8].

Further research provides for the alternative use of an additional pulse solenoid of a magnetic field strength of up to 0.5 T to compress the ring electron beam. Since the solenoid will be located in the vacuum chamber, its geometric dimensions will be limited. In order to generate a magnetic field with strength of up to 0.5 T, the solenoid will be powered by a pulse current.

### **CALCULATION AND SELECTION OF THE ADDITIONAL PULSE SOLENOID DESIGN**

Calculations and selection of the design of the pulse solenoid were carried out taking into account both the geometric dimensions of the solenoid and various options of the magnetic screen.

The magnetic screen of the solenoid and its stainless steel frame at pulse power supply should be cut. A necessary condition for research is that the magnetic field behind the screen does not extend to a distance exceeding 0.12 m, while the field of the additional solenoid does not fall into the area of the magnetron gun cathode.

The design of a pulse solenoid with a screen is presented in Fig. 1.

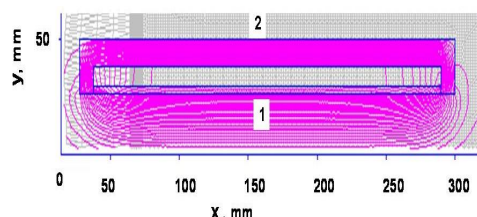

*Fig. 1. The design of a pulse solenoid.  
1 – solenoid; 2 – screen*

Based on the calculation results a solenoid of diameter of 60 mm, length of 250 mm and winding in one layer with a 3 mm thick copper wire was selected. The magnetic screen was selected in the shape of the letter «П», which allowed creating a field collapse at its edges. The thickness of the screen in calculations varied from 2 to 10 mm. Distribution of the magnetic field with and without a screen is presented in Fig. 2.

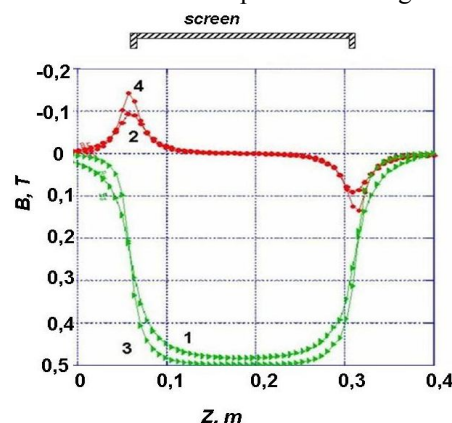

*Fig. 2. The calculated distribution of the longitudinal Hz (curve 3) and radial Hr (curve 4) fields of the solenoid using the magnetic screen of the additional solenoid and without it (curve 1 – longitudinal magnetic field; curve 2 – radial magnetic field)*

From Fig. 2 follows the necessity of using a screen which will increase the gradient of magnetic field rise ( $B_z$ ) by 1.4 times and will also allow increasing the field uniformity range at the level of 0.9 to 20 cm. The amplitude of the radial field when using the screen increases by 1.5 times (from 1.0 to 1.5 kOe).

The calculated magnetic field of a solenoid with a magnetic screen of thicknesses 10 and 5 mm is pre-

sented in Fig. 3. It can be seen that variation of screen thickness up to 10 mm does not significantly affect the distribution of the magnetic field. Thus, with a screen thickness of 5 mm the saturation of the screen material does not occur. Therefore, a screen of 5 mm thickness was selected in order to save a material and reduce a weight.

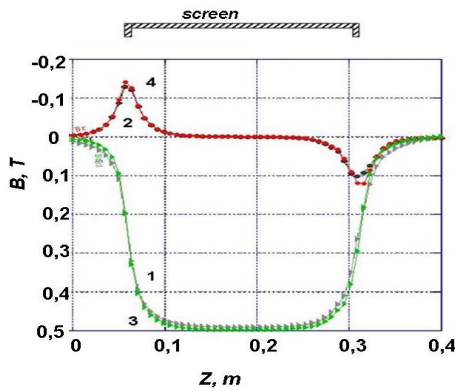

Fig. 3. Calculated distribution of longitudinal (curves 1 and 3) radial (curves 2 and 4) solenoid magnetic fields depending on the thickness of the screen (5 and 10 mm)

The possibility of creating a pulse solenoid with a uniform magnetic field over a length of 0.2 m and amplitude of up to 0.5 T follows from the performed calculations.

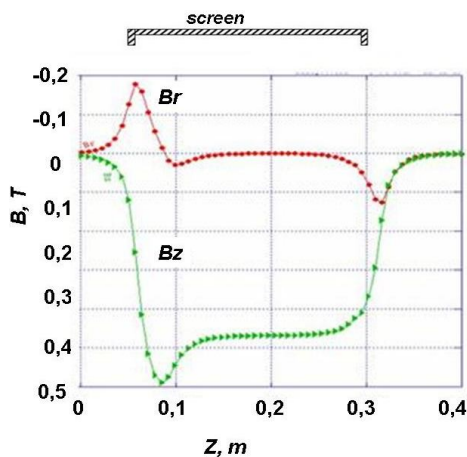

Fig. 4. The calculated distribution of the longitudinal ( $B_z$ ) and radial ( $B_r$ ) magnetic fields of the solenoid when using an additional turn

The calculated distribution of longitudinal and radial magnetic fields of the solenoid when using an additional turn is presented in Fig. 4. It can be seen that using the additional turn makes it possible to increase the rate of rise of the magnetic field up to 0.13 T/cm.

### MANUFACTURING OF ANUFACTURING OF AN ADDITIONAL PULSE SOLENOID AND DEVELOPMENT OF A POWER SUPPLY

The design of an additional pulse solenoid is presented in Fig. 5. The solenoid winding is wound with a copper wire of a cross section of 9.4 mm<sup>2</sup>, the number of winding turns is 125, the length of the winding is 250 mm. The winding is placed on a pipe with an outer diameter of 60 mm, the inductance of the solenoid winding is  $L_0$ -300  $\mu$ H, the ohmic resistance is

$R_0$ -0.1 Ohm. The screen is made of soft-magnetic alloy ST-3.

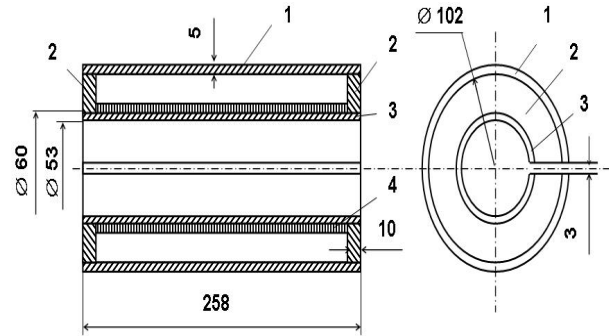

Fig. 5. Solenoid design. 1 – cylindrical cut magnetic screen; 2 – end cut screen; 3 – stainless steel pipe Kh18N10T; 4 – copper winding (4.7×2) mm<sup>2</sup>

To obtain more extended and uniform longitudinal field a magnetic screen is used. The screen, its side walls and the stainless supporting pipe on which the winding is wound are cut along the axis. The pulse solenoid will be placed inside the vacuum chamber. It will also be provided for moving targets along the axis of the solenoid.

Circuit of a pulse sinusoidal current generator for powering the pulse solenoid is presented in Fig. 6. The main elements of the circuit are: storage capacitor, a switch with a control circuit, a high-voltage transformer. The operation of the generator is based on the discharge of storage capacitor  $C_H$  charged to voltage  $U_c$  to the complex load – the solenoid winding. The sinusoidal current arising in this case in the discharge circuit is the supply current for the solenoid. The magnitude of this current depends on both the charging voltage and the parameters of the solenoid winding  $L_0$  and  $R_0$ .

The current pulse in the solenoid is controlled by a thyristor controller, the amplitude and shape of the sinusoidal current pulse are controlled and measured by oscillograph TDS-2014. To control the charging voltage of storage capacitor  $C_H$  the microammeter A2 is used.

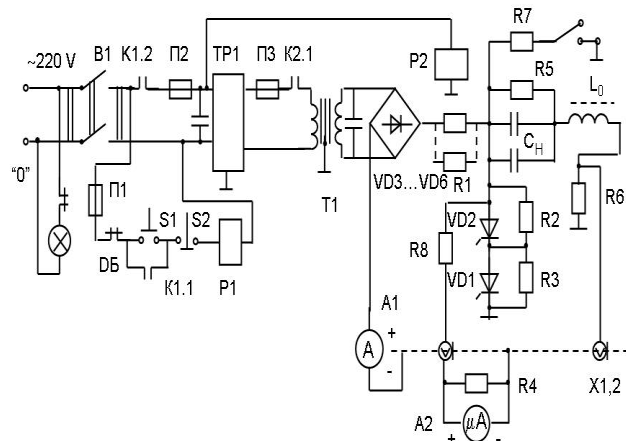

Fig. 6. Circuit of the generator for powering the pulse solenoid

An assembly of 4 thyristors in a pulse sinusoidal current generator shown in Fig. 7 was used as a switch. A powerful blocking generator TV2 triggers a thyristor switch in it. Triggering of the blocking generator is carried out by a pulse of positive polarity through galvanic isolation in the form of optocoupler (A1). The required

calculated current amplitude for generating a field on the axis 0.5 T is 1.4 kA. At a storage capacitor of 100  $\mu$ F and a wave impedance of the discharge circuit of 1.7 Ohm the charging voltage will be ranged within 2.6...2.8 kV. The dissipation power in the solenoid winding is

$$P_c = (0.7 I_{\max})^2 (T_0/2) f = 43 f \text{ (W)},$$

where  $T_0$  – oscillation period of the discharge circuit current;  $f$  – pulse repetition rate (Hz).

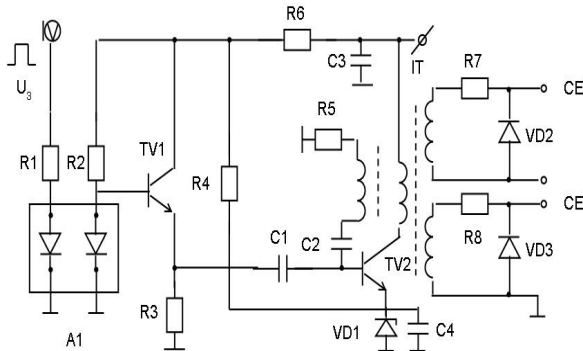

Fig. 7. Circuit of triggering the thyristors in the generator. TV1, TV2 – transistors; A1 – optocoupler; R1-R8 – resistors; IT – pulse transformer C1-C4 – capacitors; VD1-VD3 – diode; CE – control electrode

Distributions of longitudinal ( $B_z$ ) and radial ( $B_r$ ) magnetic fields were measured at various radii of 5, 10, 15 mm (Fig. 8) in the solenoid supplied with a direct current of 54 A from the thyristor controller. These measurements were carried out in increment of 10 mm. It is evident from the figure that distributions of the longitudinal magnetic field  $B_z$  (curves 1-3) at different radii do not change. The maximum magnitude of the field in amplitude reaches 0.02 T.

The length of the field with a non-uniformity of 1% is 14 cm and it reaches 19 cm with a non-uniformity of 5%. The scattering field of the longitudinal component ( $B_z$ ) at a distance  $z = 50$  mm behind the screen (see Fig. 8) tends to zero. As can be seen from Fig. 8 (curves 4-6), the radial component  $B_r$  of the magnetic field at the edges of the solenoid in amplitude does not exceed 0.0035 T.

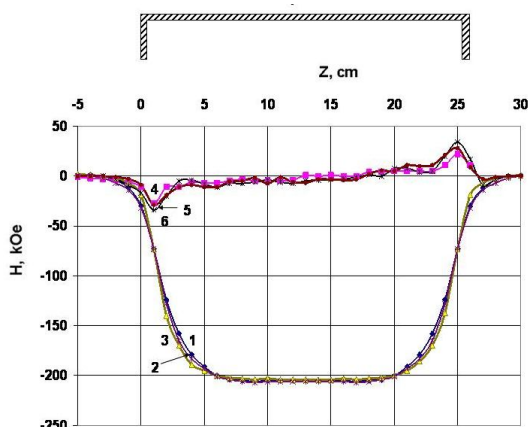

Fig. 8. Distribution of longitudinal (curves 1-3) and radial (curves 4-6) magnetic fields at different radii. 1 –  $r = 5$  mm; 2 –  $r = 10$  mm; 3 –  $r = 15$  mm; 4 –  $r = 5$  mm; 5 –  $r = 10$  mm; 6 –  $r = 15$  mm

These measurements were made in order to confirm the calculations of the magnetic field in case of inability to supply the solenoid with a pulse current. (The power supply unit is at the assembly stage). Measurements indicate that in a pulse mode and with an increase in current up to 1.4 kA, the amplitude of the longitudinal field  $B_z$  will reach 0.5 T.

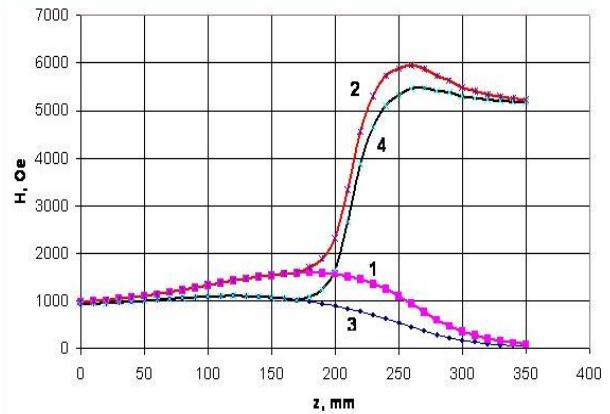

Fig. 9. Various magnetic field configurations without using additional solenoid (1, 3) at a solenoid current of 1.5 kA (2, 4)

Fig. 9 shows the experimental curves of distribution of the magnetic field at different values of the current in the solenoid coils (1, 3) and the calculated curves of distribution of the magnetic field (2, 4) at the same currents in the solenoid coil and using the additional solenoid of a current of 1.5 kA.

Using the developed additional solenoid will make it possible to carry out the necessary studies on compression of an annular electron beam and to achieve electron motion over an extended gap.

## CONCLUSIONS

The magnetic system of the installation for controlling the transverse dimensions of an electron beam formed by a magnetron gun with a secondary emission cathode was updated. The design of an additional solenoid was selected and calculated.

Solenoid with a pulsed power supply will be used in experiments. It will be located in a vacuum chamber. The possibility of generating a magnetic field with amplitude of up to 0.5 T at the pulse current amplitude of  $\sim 1.5$  kA was demonstrated. The field has a uniform area at the level of  $\pm 5\%$  over the length of  $\sim 0.2$  m.

## REFERENCES

1. A.N. Dovbnya, V.V. Zakutin, N.G. Reshetnyak, et al. Investigation of beam formation in an electron accelerator with a secondary-emission source // *Journal of Kharkov National University. Series "Nuclei, particles, fields"*. 2006, № 732, v. 2, p. 96-100.
2. A.N. Dovbnya, S.D. Lavrinenko, V.V. Zakutin, et al. Surface modification of zirconium and Zr1%Nb alloy by the electron beam of the magnetron gun-based accelerator // *Problems of Atomic Science and Technology. Series "Physics of Radiation Effects and Radiation Materials Science"*. 2011, № 2, p. 39-45.
3. A.N. Dovbnya, V.V. Zakutin, N.G. Reshetnyak. Direct-action accelerator based on the magnetron

- gun with a secondary-emission cathode and its application in radio-technologies // *Journal of Kharkov National University. Series "Nuclei, particles, fields"*. 2012, № 1017, p. 85-89.
4. V.I. Engelko, G. Mueller, A. Andreev, et al. Pulsed Electron Beam Facilities (GESA) for Surface Treatment // *Proc. of 10<sup>th</sup> International Conf. on Applied Charged Particle Accelerators in Medicine and Industry*. St.-Petersburg, Russia, 2001, p. 412-417.
  5. M.F. Vorogushin, V.A. Glukhikh, G.S. Manukyan, D.A. Karpov, M.P. Svin'in, V.I. Ehngel'ko, B.P. Yatsenko. Beam and ion-plasma technologies // *Problems of Atomic Science and Technology. Series "Physics of Radiation Effects and Radiation Materials Science"*. 2002, № 3, p. 101-109.
  6. V.A. Glukhikh, O.P. Pechersky, V.I. Engelko, B.P. Yatsenko. Modification of surface properties of materials using powerful pulsed electron beams // *Reports of the X International meeting on the use of charged particle accelerators in industry and medicine*. St.-Petersburg, 2001, p. 445-447.
  7. M.I. Ayzatsky, A.N. Dovbnya, A.S. Mazmanishvili, N.G. Reshetnyak, V.P. Romas'ko, I.A. Chertishchev. Studies on formation of the radially-directed electron beam generated by the magnetron gun with a secondary emission cathode // *Problems of Atomic Science and Technology. Series "Nuclear Physics Investigations"*. 2016, № 3, p. 11-16.
  8. A.S. Mazmanishvili, N.G. Reshetnyak, V.P. Romasko, I.A. Chertischev. Electron beam transversion management on exit of magnetic gun by gradient magnetic field // *Abstracts of the XXVI Intern. Conf. on Accelerating of the Charged Particles*. Kharkov, 2019, p. 47-48.

Article received 24.02.2020

### **РАЗРАБОТКА ИМПУЛЬСНОГО СОЛЕНОИДА С АМПЛИТУДОЙ МАГНИТНОГО ПОЛЯ ДО 0,5 Тл И ИМПУЛЬСНОГО ГЕНЕРАТОРА СИНУСОИДАЛЬНОГО ТОКА ДЛЯ ЕГО ПИТАНИЯ**

***Н.Г. Решетняк, В.П. Ромасько, И.А. Чертищев***

Проведена модернизация магнитной системы установки для управления поперечными размерами электронного пучка, формируемого магнетронной пушкой с вторично-эмиссионным катодом. В экспериментах будет использован дополнительный соленоид с импульсным питанием, расположенный в вакуумной камере на расстоянии 0,05...0,1 м от среза пушки. Проведен выбор и расчет конструкции соленоида. Показана возможность получения магнитного поля с амплитудой до 0,5 Тл, при амплитуде импульсного тока ~1,5 кА. Поле имеет однородную часть на уровне  $\pm 5\%$  на длине ~0,2 м.

### **РОЗРОБКА ІМПУЛЬСНОГО СОЛЕНОЇДА З АМПЛІТУДОЮ МАГНІТНОГО ПОЛЯ ДО 0,5 Тл І ІМПУЛЬСНОГО ГЕНЕРАТОРА СИНУСОЇДАЛЬНОГО СТРУМУ ДЛЯ ЙОГО ЖИВЛЕННЯ**

***М.Г. Решетняк, В.П. Ромасько, І.О. Чертищев***

Проведено модернізацію магнітної системи установки для управління поперечними розмірами електронного пучка, формованого магнетронною гарматою з вторинно-емісійним катодом. У дослідженнях буде використано додатковий соленоїд з імпульсним живленням, що розташований у вакуумній камері на відстані 0,05...0,1 м від зрізу гармати. Проведено вибір і розрахунок конструкції соленоїда. Показана можливість отримання магнітного поля з амплітудою до 0,5 Тл, при амплітуді імпульсного струму ~1,5 кА. Поле має однорідну частину на рівні  $\pm 5\%$  на довжині ~0,2 м.