

2023

## Influence of deep excavation on behavior of adjacent single pile: effect of pile location

Mostafa Ibrahim Lotfy, Marwan Shahin, Ahmed Farouk

Follow this and additional works at: <https://digitalcommons.aaru.edu.jo/erjeng>

---

### Recommended Citation

Ibrahim Lotfy, Marwan Shahin, Ahmed Farouk, Mostafa (2023) "Influence of deep excavation on behavior of adjacent single pile: effect of pile location," *Journal of Engineering Research: Vol. 7: Iss. 3, Article 31*. Available at: <https://digitalcommons.aaru.edu.jo/erjeng/vol7/iss3/31>

This Article is brought to you for free and open access by Arab Journals Platform. It has been accepted for inclusion in Journal of Engineering Research by an authorized editor. The journal is hosted on [Digital Commons](#), an Elsevier platform. For more information, please contact [rakan@aar.edu.jo](mailto:rakan@aar.edu.jo), [marah@aar.edu.jo](mailto:marah@aar.edu.jo), [u.murad@aar.edu.jo](mailto:u.murad@aar.edu.jo).

# Influence of deep excavation on behavior of adjacent single pile: effect of pile location

Dr. Marwan Shahin<sup>1</sup>, Dr. Ahmed Farouk<sup>2</sup>, Eng. Mostafa Lotfy<sup>3</sup>

<sup>1</sup> Professor, Faculty of Engineering, Tanta University, Egypt

E-mail: [marwan.shahin@f-eng.tanta.edu.eg](mailto:marwan.shahin@f-eng.tanta.edu.eg)

<sup>2</sup> Professor, Faculty of Engineering, Tanta University, Egypt

E-mail: [drafarouk@f-eng.tanta.edu.eg](mailto:drafarouk@f-eng.tanta.edu.eg)

<sup>3</sup> Civil Engineer.

E-mail: [mostafa132615@f-eng.tanta.edu.eg](mailto:mostafa132615@f-eng.tanta.edu.eg)

**Abstract:** Even when located atop piles, deep excavations might result in Settlement and harm to nearby buildings. This work aims to investigate single-pile reactions to deep-braced excavation-induced soil movement in soft clay with a sand covering. The main goal of the experiment is to determine how a vertical single pile responds to produced axial force, lateral deflection, induced bending moment, and pile settlement. The pile's diameter (dp) is 5 meters, and its embedded length (Lp) is 22 meters. The pile horizontally from the diaphragm wall is situated 3.75 meters (.25 He). The pile was simulated using the "Embedded pile" structural element. To enhance comprehension of the behavior of a single pile, a parametric analysis was conducted. to offer more information regarding the pile's response. Design, procedure, and strategy A thorough three-dimensional numerical study is performed to explore pile responses during a nearby deep-braced excavation using the explicit finite element code PLAXIS 3D. **Conclusions:** The acquired data made it possible to fully comprehend the phenomena of soil-pile-structure interactions as well as the pile reaction. The results show that there could be significant axial forces, lateral deflections, and bending moments in the surrounding piles as a result of the deep excavation. Parametric research revealed that the position of the pile has a significant impact on the pile reactions. This work used 3D numerical modeling to fully examine the pile reaction in multi-layered soil. In this investigation, the Hardening soil model with small-strain stiffness was employed to account for the soil's nonlinear small-strain behavior.

**Keywords:** Pile response, Finite element modelling, Soil-structure interaction, Deep excavation, Soil movements group.

## INTRODUCTION

However, it is impossible to build tunnels or deep excavations without impacting nearby structures. The dirt inexorably flows toward the excavation as it becomes deeper, resulting in both vertical and horizontal deformations. This could have an impact on the pile foundation close by (Poulos and Chen, 1997[1]; Schanz and Vermeer, 1998[2]; Leung et al., 2006[3]; Ng et al., 2017[4]), because of this. Therefore, since concrete piles are typically not made to support heavy

lateral loads, it is crucial to fully comprehend the detrimental impacts of excavation on nearby piles. The studies conducted by Leung et al. (2000) [5], Poulos and Chen (1996[6], Ng et al. (2017) [4], Soomro et al. (2018[7], 2019a[8]), Nishanthan et al. (2017) [9], and Liyanapathirana and Nishanthan (2016) [10] are among those that can be consulted. or [11] Shakeel and Ng (2018), Ayasrah, M., Fattah, M., (2023) [12], Jawad, F. W, Fattah, M. Y., (2019) ) [13], M. Shahin; A. Farouk; M. Saad., (2022) [14], A. El Sawwaf; A. Nazir; W. R. Azzam., (2022) [15]. The majority of research has been done on how inhomogeneous layer piles—clay or sand—respond to various conditions. The first method relies on model testing (Chen et al., 1997) [16] and centrifuge modeling methodology in clay (Leung et al., 2006[17]; Ong et al., 2009[18] and sand (Leung et al., 2003[19]; Zheng et al., 2012[20]; Shi et al., 2019[21]). These studies highlight a few fundamental aspects of this issue. Nevertheless, the experimental procedures might be costly and time-consuming for the initial design. A streamlined technique called the two-stage analysis method, or "TSAM," was also used to assess the reactions of piles exposed to soil movements brought on by excavation (Poulos and Chen, 1996[6], 1997[1]). The boundary element method, or "BEM," is the most exemplary implementation of "TSAM." Nevertheless, this approach treats the surrounding soil in plane strain conditions as a homogenous linear elastic material, which makes it challenging to apply to multi-layered and nonlinear issues. This paper describes the influence of deep excavation on the behavior of adjacent single pile on a different soil profile, which contains a thick layer of soft clay that is 21.5 meters above 6.4 meters of compacted sand.

### A. Three – dimensional numerical analysis.

Using Plaxis 3D, a commercial software package, a three-dimensional coupled consolidation numerical analysis was carried out to examine the reaction of an axially loaded pile

next to multi-strutted deep excavation. Fig. 1 illustrates the typical excavation geometry that is frequently employed in contemporary urban development. The final excavation depth (He) was 15 m, supported by a diaphragm wall with three strut levels that was 20 m deep and 1 m thick. The struts were separated 10 meters horizontally and 5 meters vertically. Steel pipes with an outside diameter of 600 mm and a thickness of 25 mm were employed as struts in the investigation. The struts have an axial stiffness of  $9.03 \times 10^6$  kN. In this work, bottom-up excavation supported by struts was utilized, which is typical in the field. A reinforced concrete pile was used for this basic investigation. There is a 500 KN axial load. The pile diameter ( $d_p = 0.5$  m) and the center to center spacing ( $0.25H_e$

$-0.5H_e - H_e - 3H_e$ ) were the distances between the wall and pile (P).

### B. General description of the model

A thorough three-dimensional numerical study was carried out to look at the pile reaction resulting from a nearby deep multi-strutted excavation using the finite element numerical code PLAXIS 3 D. Diaphragm walls with struts are one of the most used methods for supporting deep excavations. The procedure of constructing a deep excavation around an existing pile foundation may really entail several steps. First, the wall is built to the necessary depth. Following that, a little amount of excavation is done to create space for the retaining wall's anchor or strut to be installed. Following that, the earth is gradually dug up to the excavation's final depth.

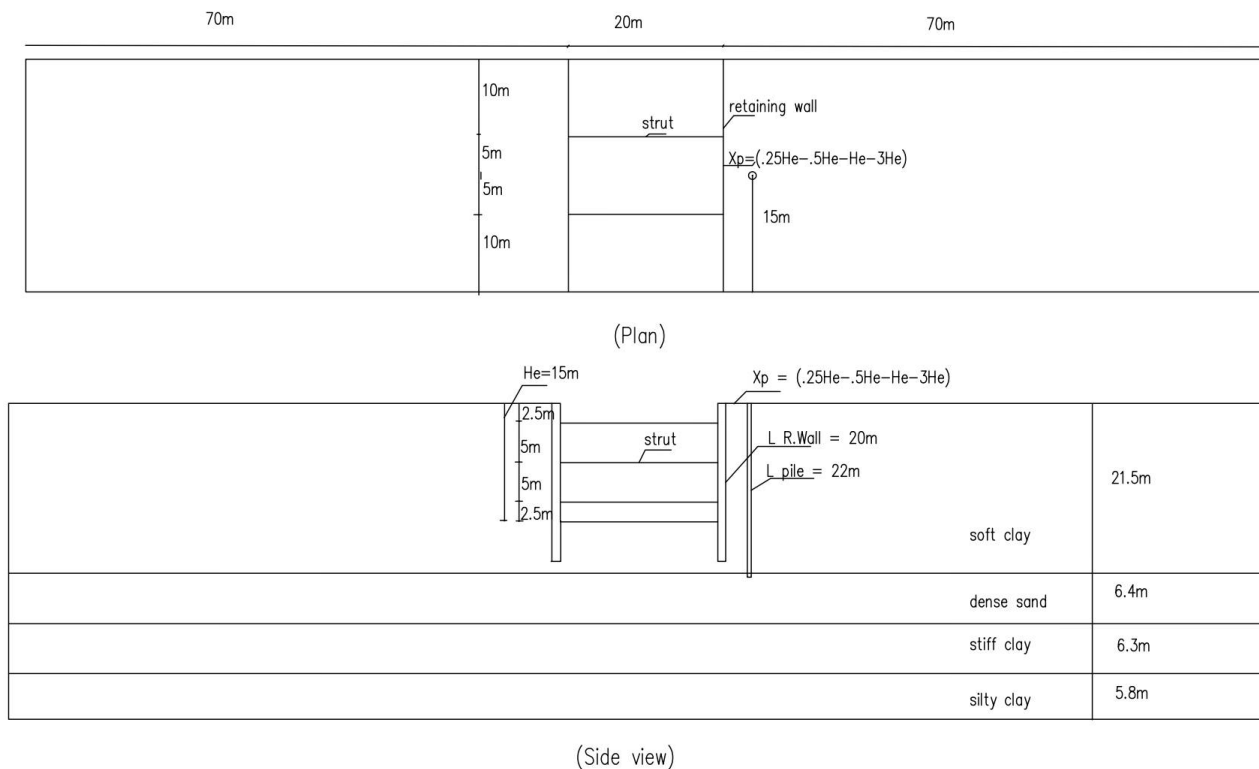


Figure 1. Geometry of the model (side and plan view)

### A. Geometry of the model

In current urban development, typical excavation geometry is seen in Fig. 1. A 20-meter-deep, one-meter-thick diaphragm wall with three strut levels supported the ultimate excavation depth (He) of 15 meters. There were 10 meters of horizontal and 5 meters of vertical strut spacing. In the investigation, steel pipes with an outside diameter of 600 mm and a thickness of 25 mm were utilized as struts. Saturated soft clay makes comprises the top 21.5 meters of the earth in this reference model. A thicker, firmer layer of sand, measuring 6.4 meters, sits beneath this clay layer. The clay is seven meters thick and hard. This layer of hard clay is covered by 6.3 meters of thick, silty, clayey sand that descends to a considerable depth. The nonlinear stress-strain soil behavior was modeled using the hardening soil model with small strain stiffness mode. The HSsmall model's input parameters for the clay layer are displayed in Table 1. Table 1 displays the sand layer properties, nevertheless. Parameters from Table 1 were

taken from field tests from asite in Egypt. The dimensions of the 3D numerical model are width \_ length \_ height = 160\_30\_40 m. These dimensions are adequate to prevent any impact from the model borders and to allow for the development of any potential collapse mechanism. These bounds were selected based on the worst-case scenarios from previous sources and adjusted to fit this soil profile Table I. Fig. 1 shows the geometry of the model (side and plan views) that was used for the analysis. The volume that needs to be dug has dimensions of (20\_30\_15) m<sup>3</sup>, which stand for the width (B), length, and maximum depth of excavation (He), respectively. A diaphragm wall 20 m long and 1 m thick, double the maximum excavation depth, and three tiers of steel props with an axial stiffness of  $210 \text{ E}6 \text{ KN.m}$  were employed to support the excavation to provide a sufficiently high safety factor against the structure's stability. Approximately one meter below the unsupported excavation depth, the first level of supports is constructed (Fig. 1). While the typical vertical prop spacing is 5 meters, the average horizontal prop spacing

is 10 meters. The pile's diameter ( $d_p$ ) is .5 meters, and its embedded length ( $L_p$ ) is 22 meters. The pile is situated 3.75 meters (.25 He) horizontally from the diaphragm wall. The "Embedded pile" structural element, which consists of embedded pile components with unique interface features for soil-pile interactions, was used to replicate the pile. Based on trials, Embedded pile were used in this model because all pile results, like Settlement, lateral deflection, Bending moment, etc., could be deduced accurately. Based on trials, there is no significant difference if pile is extended more in dense sand. Every node in this numerical analysis, the embedded pile element, has six degrees of freedom: three translations ( $U_x$ ,  $U_y$ , and  $U_z$ ) and three rotations ( $A_x$ ,  $A_y$ , and  $A_z$ ). In this reference model, the free-head situation—where translations and rotations are both free—was used. An overview of the embedded pile's material specifications is given in Table 3. A tetrahedral element with 10 nodes was used to imitate soil. The single pile's surrounding soil mesh was fine-tuned (fineness factor: 0.3536), and it gets coarser the farther it is from the pile. In the end, the mesh included 20266 nodes and 12841 soil components (Fig 2). Plate components are used to simulate the diaphragm wall and anchors, respectively. It is anticipated that the wall, pile, and props will behave in an elastic, linear, and isotropic manner. Based on trials, validation was made to ensure the accuracy of the results.

Table I. soil parameters used in the analysis

Description/parameter	Soft clay	Dense sand
$\gamma_{unsat}$ KN/m <sup>3</sup>	16	18.52
$\gamma_{sat}$ KN/m <sup>3</sup>	17	19.52
$E$ KN/m <sup>2</sup>	2800	5600
$\nu \cdot G$ KN/m <sup>2</sup>	0.35	0.3
$G$ KN/m <sup>2</sup>	1037	121.2
$\phi$	23	37
$C_{ref}$ KN/m <sup>2</sup>	14	0.01

Table II. Material properties of the embedded pile

Description/parameter	Unit value
Unit weight, $c$ (kN/m <sup>3</sup> )	24
Young modulus, $E$ (GPa)	50
Diameter, $d_p$ (m)	0.5
Skin resistance at top layer, $T$ (kN/m) for $Z_p = 0 - 28m$	0-175
Skin resistance at bottom layer, $T$ (kN/m) for $Z_p = 28 - 40m$	175-245
Base resistance (kN)	17000

### B. Construction sequences:

The whole building process used strutting and phased excavation. Every step begins with the removal of dirt, and all struts are then installed one meter above the excavation's bottom. Excavation and strutting phases can be followed one after the other step-by-step till the ultimate excavation bottom is achieved. The same steps were made into the 3D model.

### C. Numerical modeling procedures:

The following are the described methodical steps of the numerical simulation of the issue using the Plaxis code:

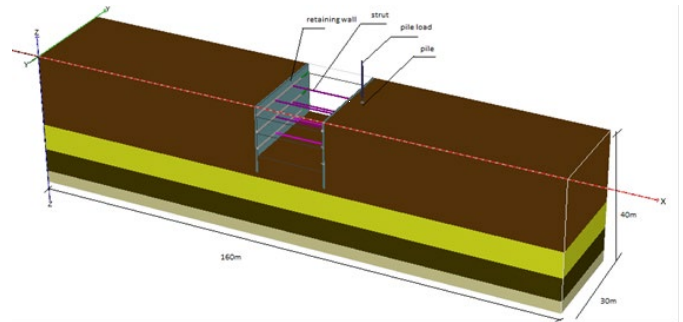


Figure 2: finite element 3D model

- General setting: Here, the minimum size of the draw area must be provided together with the kind of finite elements.
- Developing a geometry model: A geometry model need to have a realistic subsurface division into discrete soil layers, structural elements, phases of construction, and loadings.
- Boundary conditions: Conventional boundaries were used. Material data sets: The geometry has to be assigned with the soil model and the relevant material properties. The system is the same for constructions (such as walls, plates, piles, struts, etc.).
- Mesh creation: Plaxis enables completely automated mesh creation. beginning conditions: The beginning circumstances must be created, nevertheless, before the computations may begin. The beginning conditions consist of the initial groundwater conditions, the first effective stress state and the initial geometric configuration.
- Performing calculations: The Staged construction calculation option in Plaxis allows you to model the excavation construction process.
- Viewing the output results: The output program allows you to assess the results when the computation is finished.

## II. EFFECT OF PILE LOCATION

For this reference model, The pile responds via bending moment, settling, and lateral deflection. It is frequently seen that pile responses rise with excavation depth due to tension release and soil movement caused by excavation.

### A. Pile lateral deflection

Fig 3,4,5 and 6 showed plaxis result for the lateral deflection on pile. Fig 7, 8,9and10 illustrates the pile lateral deflection profile owing to the excavation in four cases of  $X_p = .25He$ ,  $X_p = .5He$ ,  $X_p = He$ ,  $X_p = 3He$ . It showed

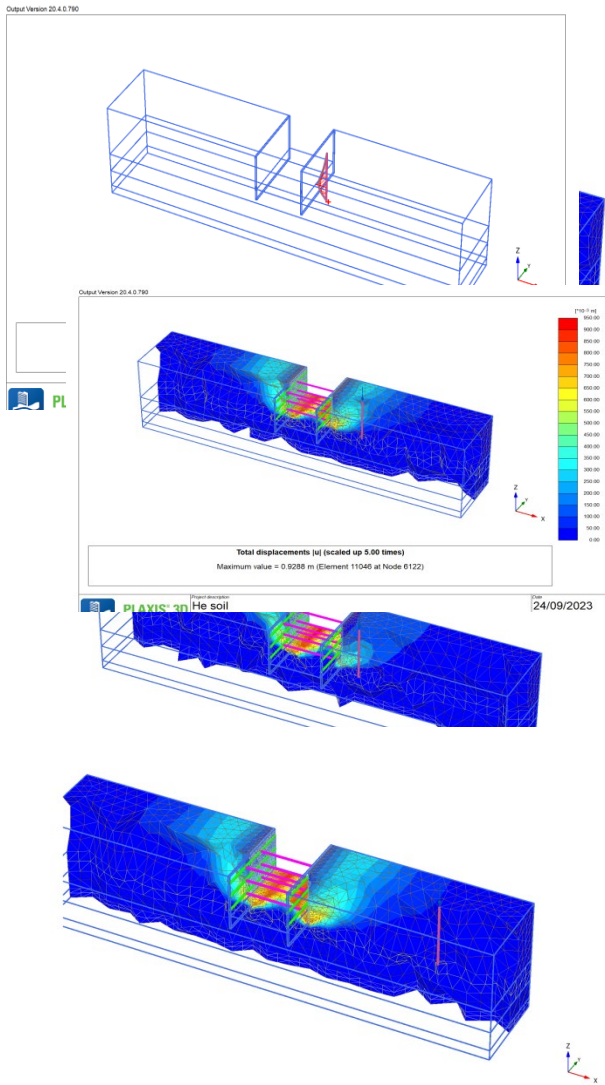
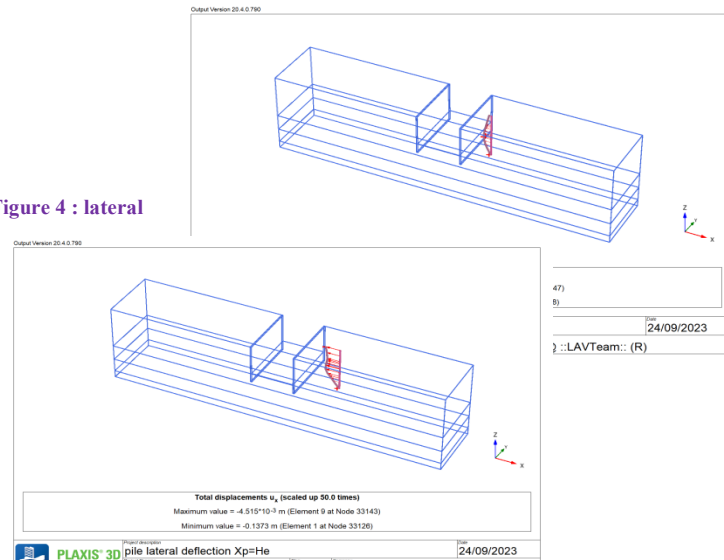


Figure 3 : lateral deflection on pile at 0.25 He

Figure 4 : lateral



deflection on pile at 0.5 He  
Figure 5 : lateral deflection on pile at He

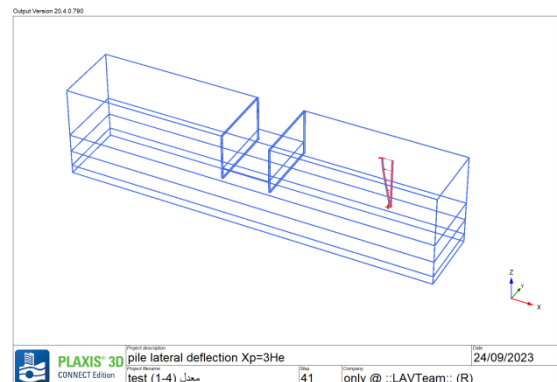
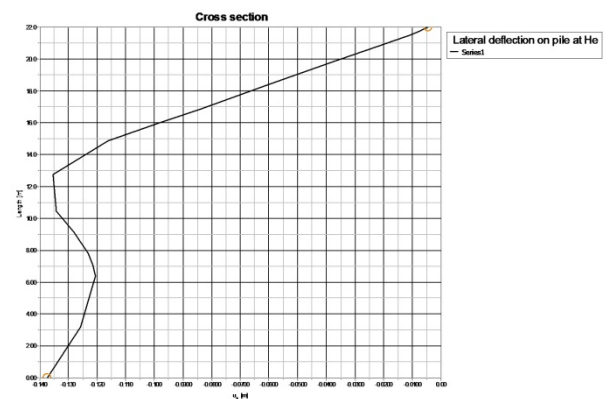
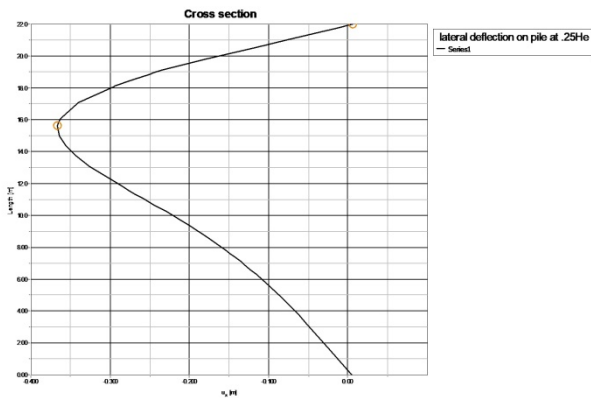


Figure 6 : lateral deflection on pile at 3 He

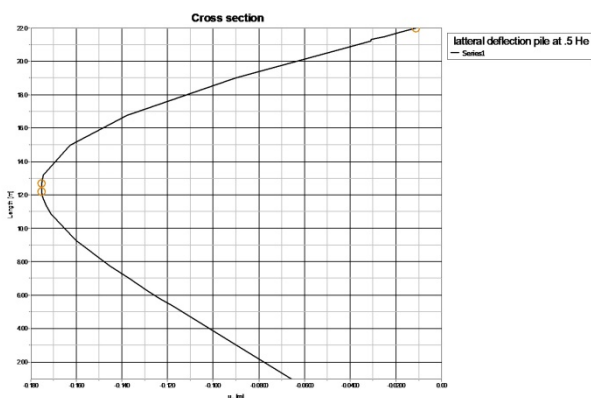
The negative values indicate that the pile is moving closer to excavation. As in the figures, it can be observed that the pile was displaced in the direction of the excavation in the four cases of  $X_p$  as expected, because the excavation led to stress release and displacement of soil towards



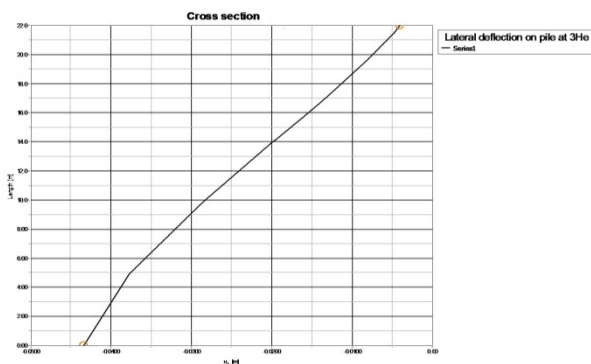
Excavation. Fig 11 illustrates the comparison between four



**Figure 7 : lateral deflection on pile at 0.25 He**  
cases  $X_p=0.25H_e$ ,  $X_p=0.5H_e$ ,  $X_p=H_e$ ,  $X_p=3H_e$ . It showed that in the case of  $X_p=0.25H_e$ , the results showed the highest lateral deflection. While in the case of  $X_p=3H_e$ , the result showed the lowest lateral deflection. During the early steps

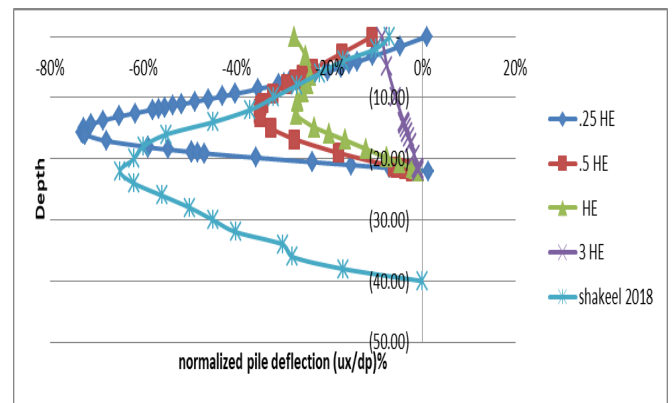


**Figure 8 : lateral deflection on pile at 0.5 He**



**Figure 9 : lateral deflection on pile at 3He**

**Figure 10: lateral deflection on a pile at  $H_e$**   
of excavation, As seen in Figure 7, a cantilever-type deformation was noted for the lateral deflection of the pile. Due to the kinematics of the wall's depth deflection and the impact of the stiffness of the props, as the excavation moves deeper ( $H_e > 10m$ ), the pile shows a deep inward displacement profile, with the greatest displacement being noted once at the pile's head. Fig. 7 also displays, for comparison's sake, the excavation-induced lateral displacement from the case study that was published by M. Shakeel, M., and Ng, C.W. (2018) [11]. In this case study, a 40-meter-long and 1-meter-diameter concrete pile immersed in clay had its lateral displacement caused by excavation measured. The greatest estimated lateral deflection in this investigation was 72%, although the maximum observed lateral deflection was just 65%. There are undoubtedly a number of contributing elements, but the two most important ones are the kind of soil and the rigidity of the support.



**Figure 11: lateral deflection on a single pile**

### B. Pile settlement

The laden pile settling caused by the excavation in the four cases of  $X_p=0.25H_e$ ,  $X_p=0.5H_e$ ,  $X_p=H_e$ , and  $X_p=3H_e$  along the horizontal axis is shown in Fig. 8. while  $u_x/d_p$  in the vertical axis, which  $u_x$  is the Settlement and  $d_p$  is the pile diameter. The data show that the pile settling rises with increasing distance. Furthermore, along the pile axis, the Settlement remains constant. The greatest pile settlement for the cases of  $X_p=0.25H_e$ ,  $X_p=0.5H_e$ , and  $X_p=H_e$  is, respectively, 2.7%, 3.4%, and 4.5% from pile diameter  $d_p$ . The neighboring excavation might potentially result in difficulty with the serviceability of pile foundations. However, because the pile reactions in the situation of  $X_p=3H_e$  became insignificant, the Settlement evolved to the lowest level. For purposes of comparison,

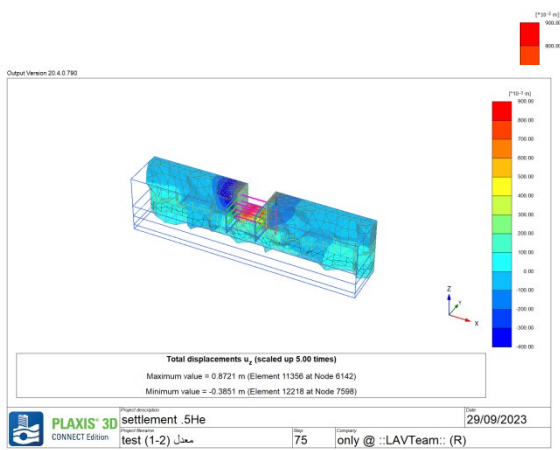


Figure 12: Settlement on a pile at 0.25 He

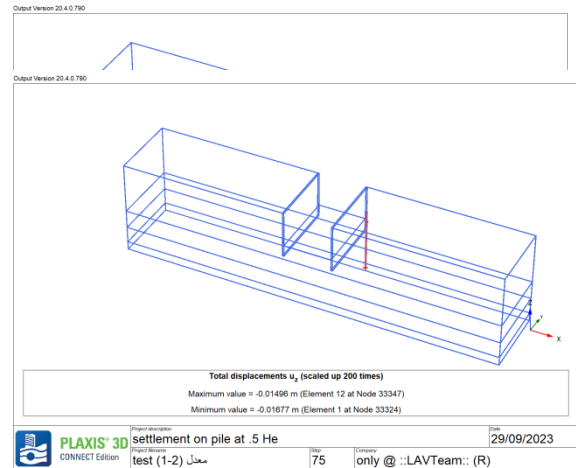


Figure 13: Settlement on a pile at 0.5 He

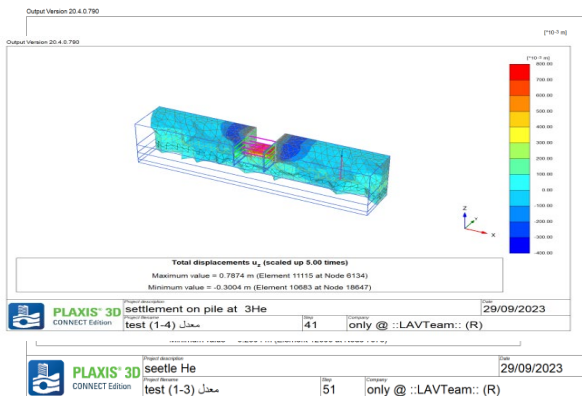


Figure 14: Settlement on a pile at He

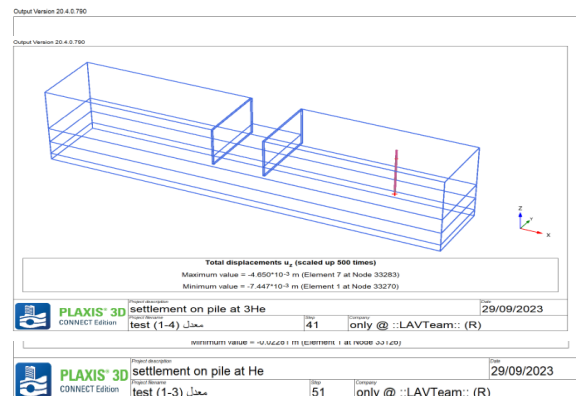


Figure 15: settlement on a pile at 3He

Excavation-induced Settlement from case history reported by Shakeel, M. and Ng, C.W. (2018), In this case study, a 40-meter-long and 1-meter-diameter concrete pile immersed in clay had its excavation-induced Settlement assessed. The greatest calculated Settlement in this investigation was not as high as the maximum observed Settlement of 2%. There are undoubtedly a number of contributing elements, but the two most important ones are the kind of soil and the rigidity of the support.

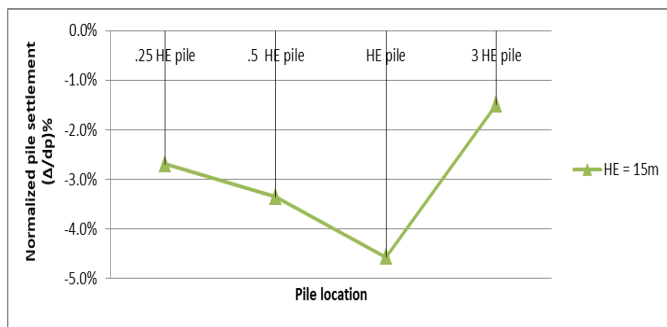
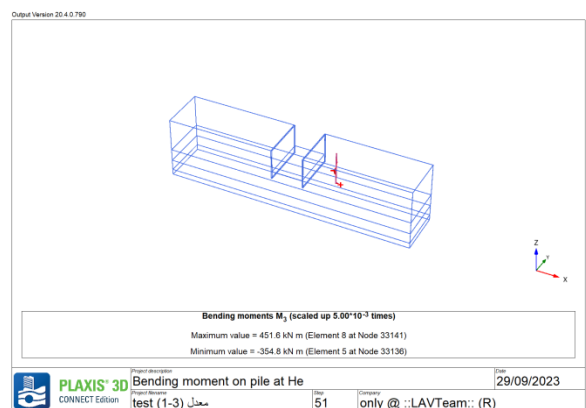


Figure 16: settlement on a single pile

Fig 17,18,19 and 20 showed plaxis result for the lateral



deflection on pile.

### C. Pile bending moment

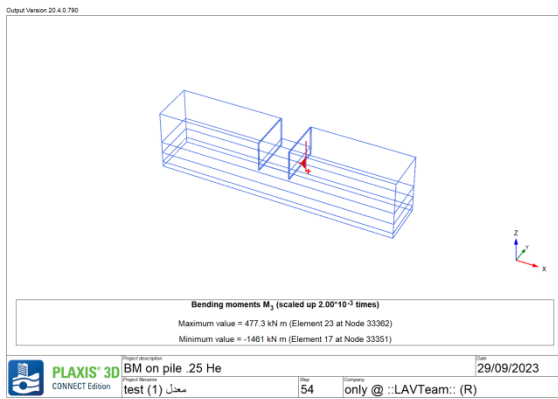


Figure 17 : Bending moment on pile at 0.25 He

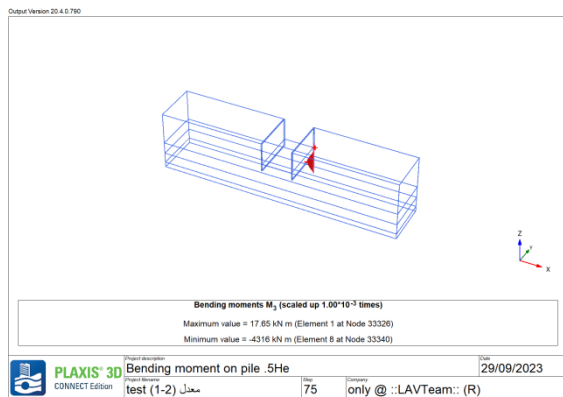


Figure 18: Bending moment on pile at 0.5 He

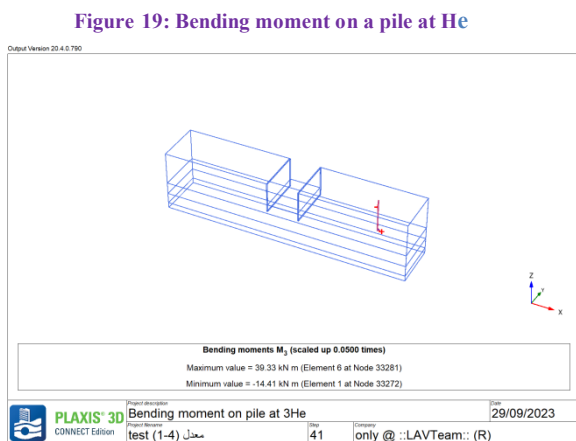
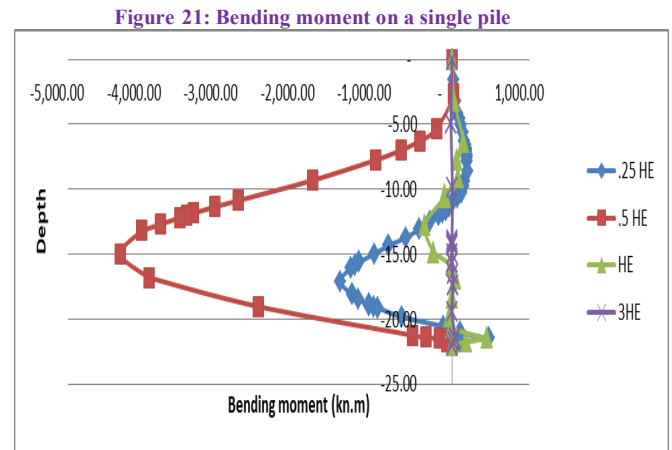


Figure 19: Bending moment on a pile at He

The negative bending moment magnitude in Fig. 21 indicates that the pile is bending toward the excavation. However, a positive bending moment forms in the bottom part due to the 0.5 meters of pile embedding in the heavy sand. The data displayed in Fig 21 indicate that the pile bending moment decreases as the distance increases.



### III. CONCLUSION

This work studied single pile behavior induced by soil movements embedded in bilayer soil (soft clay overlaying heavy sand) generated by deep-braced excavation using a comprehensive three-dimensional numerical analysis. To find out how excavation depth and pile position affect the excavation, a comprehensive parametric research is conducted. The 3D data show that the pile's reaction in terms of bending moment, lateral deflection, and pile height during excavation was caused by soil movements and soil stress alleviation. The depth of excavation caused a large rise in Settlement. Bending moment and pile lateral deflection in three dimensions.

1. As one moves farther away from the excavation, the pile's maximum lateral displacement exponentially ( $u_x/d_p$ ) decreases from 70% to 10%.
2. As one moves farther away from the excavation, the pile's maximum bending moment exponentially decreases from 4500 kN.m to 500 kN.m.
3. The pile's maximum Settlement ( $\Delta/d_p$ ) increases exponentially from 3% to 5% as it gets farther away from the excavation.
4. Lateral deflection, settlement, and bending moment become negligible at 3He from the wall. The pile next to the excavation had the greatest deflection and the least amount of settling.

Therefore, it can be concluded that if the appropriate safety measures are not followed, a new excavation site may have a significant impact on the stability of the current pile structure, depending on the depth and distance of the excavation as well as the qualities of the soil and pile.



Based on the findings and recommendations of the research, it is advised that the geotechnical designer consider every factor that might affect the safety of the structures supported on pile foundations located close to the deep excavations during the design phase. It is significant to note that other factors like the kind and stiffness of the support system, the effect of pile diameter and length, or the behavior of piles adjacent to deep excavations were not investigated in this study. It suggests that future studies examine these areas. It also suggests investigating the effects of large-scale excavation on the behavior of pile groups joined by raft foundations.

#### IV. REFERENCES:

- [1]. Poulos, H. and Chen, L.T. (1997), "Pile response due to excavation-induced lateral soil movement", *Journal of Geotechnical and Geoenvironmental Engineering*, Vol. 123 No. 2, pp. 94-99.
- [2]. Schanz, T. and Vermeer, P. (1998), "Special issue on pre-failure deformation behaviour of geomaterials", *Geotechnique*, Vol. 48, pp. 383-387.
- [3]. Leung, C.F., Ong, D.E. and Chow, Y.K. (2006), "Pile behavior due to excavation-induced soil movement in clay. II: collapsed wall", *Journal of Geotechnical and Geoenvironmental Engineering*, Vol. 132 No. 1, pp. 45-53.
- [4]. Ng, C.W., Wei, J., Poulos, H. and Liu, H. (2017), "Effects of multipropped excavation on an adjacent floating pile", *Journal of Geotechnical and Geoenvironmental Engineering*, Vol. 143 No. 7, p. 04-17-21.
- [5]. Leung, C.F., Chow, Y.K. and Shen, R.F. (2000), "Behavior of pile subject to excavation-induced soil movement", *Journal of Geotechnical and Geoenvironmental Engineering*, Vol. 126 No. 11, pp. 947-954.
- [6]. Poulos, H. and Chen, L.T. (1996), "Pile response due to unsupported excavation-induced lateral soil movement", *Canadian Geotechnical Journal*, Vol. 33 No. 4, pp. 670-677.
- [7]. Soomro, M.A., Brohi, A.S., Soomro, M.A. and Bangwar, D.K. (2018), "3D numerical modeling of pile group responses to excavation-induced stress release in silty clay", *Engineering, Technology & Applied Science Research*, Vol. 8 No. 1, pp. 2577-2584.
- [8]. Soomro, M.A., Mangnejo, D.A. and Bhanbhro, R. (2019a), "3D finite element analysis of pile responses to adjacent excavation in soft clay: effects of different excavation depths systems relative to a floating pile", *Tunnelling and Underground Space Technology*, Vol. 86, pp. 138-155.
- [9]. Nishanthan, R., Liyanapathirana, D.S. and Leo, C.J. (2017), "Shielding effect in pile groups adjacent to deep unbraced and braced excavations", *International Journal of Geotechnical Engineering*, Vol. 11 No. 2, pp. 162-174.
- [10]. Liyanapathirana, D. and Nishanthan, R. (2016), "Influence of deep excavation induced ground movements on adjacent piles", *Tunnelling and Underground Space Technology*, Vol. 52, pp. 168-181.
- [11]. Shakeel, M. and Ng, C.W. (2018), "Settlement and load transfer mechanism of a pile group adjacent to a deep excavation in soft clay", *Computers and Geotechnics*, Vol. 96, pp. 55-72.
- [12]. Ayasrah, M., Fattah, M. Y., (2023), "Finite Element Analysis of Two Nearby Interfering Strip Footings Embedded in Saturated Cohesive Soils", *Civil Engineering Journal*, Vol. 9, No. 03,, pp.752-769.
- [13]. Jawad, F. W., Fattah, M. Y., (2019), "Finite Element Analysis of the Bearing Capacity of Footings Nearby Slopes", *International Review of Civil Engineering*, Vol. 10, No. 1,, pp.1-7,DOI.
- [14]. M.Shahin; A.Farouk; M.Saad.,(2022). , " Numerical analysis of group effect on dragload on piles subjected to negative skin friction, *Journal of Engineering Research Volume 6, Issue 1, Pages 29-33.*
- [15]. A.Elsawwaf; A.Nazir; W.R.Azzam.,(2022), " Assessment of Micropiled Rafts Performance under Pure Lateral Loading", *Journal of Engineering Research Volume 6, Issue 2, Pages 23-28.*
- [16]. Chen, L.T., Poulos, H.G. and Hull, T.S. (1997), "Model tests on pile groups subjected to lateral soil movement", *Soils and Foundations*, Vol. 37 No. 1, pp. 1-12.
- [17]. Leung, C.F., Lim, J.K. and Shen, R.F. (2003), "Behavior of pile groups subject to excavation-induced soil movement", *3D numerical analysis of pile response.*
- [18]. Zheng, G., Peng, S.Y., Ng, C.W.W. and Diao, Y. (2012), "Excavation effects on pile behaviour and capacity", *Canadian Geotechnical Journal*, Vol. 49 No. 12, pp. 1347-1356.
- [19]. Shi, J., Wei, J., Ng, C.W. and Lu, H. (2019), "Stress transfer mechanisms and Settlement of a floating pile due to adjacent multi-propped deep excavation in dry sand", *Computers and Geotechnics*, Vol. 116, pp. 103-116.
- [20]. Leung, C.F., Ong, D.E. and Chow, Y.K. (2006), "Pile behavior due to excavation-induced soil movement in clay. II: collapsed wall", *Journal of Geotechnical and Geoenvironmental Engineering*, Vol. 132 No. 1, pp. 45-53.
- [21]. Ong, D.E., C. Leung, C.F. and Chow, Y.K. (2009), "Behavior of pile groups subject to excavation-induced soil



movement in very soft clay", Journal of Geotechnical and Geoenvironmental Engineering, Vol. 135No. 10, pp. 1462-1474.