

Evaluation of Graphite and TiO₂ as susceptors for microwave dewaxing in ceramic shell casting processes of artworks

I. Pérez-Conesa^{1*}, J. Fayos-Fernández², J. A. Aguilar Galea³, J. Monzó-Cabrera², R. Pérez-Campos²

*corresponding author

¹Departamento de Bellas Artes, Universidad de La Laguna, iperecon@ull.edu.es

²Departamento de Tecnologías de la Información y las Comunicaciones, ETSI Telecomunicación, Universidad Politécnica de Cartagena

³Departamento de Escultura e Historia de las Artes Plásticas, Facultad de Bellas Artes, Universidad de Sevilla

Abstract: The main problems of the traditional foundry dewaxing processes in fine arts workshops are the emission of gases, the loss of 80% of the wax, the high electrical consumption, and the high risks for the operators. The introduction of the microwave technology for dewaxing of ceramic shell molds allows to minimize some of these problems, although the use of electromagnetic susceptors that capture the radiated energy and transform it into heat is required. This article describes different microwave dewaxing tests using TiO₂ and graphite as susceptors. The results obtained show that this technique is viable, allowing the casting process to be carried out with a low percentage of breakage problems in the mold and significantly reducing the emitted gases and electricity consumption. The technique allows to recover in the same operation around 90% of the wax used in small and medium format objects. The tests show that the selection of the material used as a susceptor, the area of application and the power regimes, are fundamental to enable a controlled, soft and non-aggressive dewaxing, both for the art molds and for the environment, as opposed to the traditional Flash Dewaxing technique. In this way, it is possible to change the foundry of ceramic shells for artworks to achieve high levels of performance and safety, and to save energy, time and materials.

Keywords: Microwave, dewaxing, Artistic Casting, ceramic shells, susceptors, thermal shock

1. Introduction

The main objective of the foundry sector is the creation of metal pieces by pouring liquid metal into refractory molds. In the lost wax casting technique, the wax model that acts as a support of the refractory mold is eliminated, so that the metal can be poured into the space that the wax was occupying previously, as described in (Sias, 2005). Dewaxing is a step previous to melting and casting of the metal and is also the most complicated and delicate action of the process. Davey (2009), explains that its success is conditioned to the removal of the moisture from the mold and any traces of wax, since the gasification of wax, which is combustible, would cause serious damages in the ceramic negative, ruining the whole operation. In ceramic husk technology, dewaxing is the most critical phase, with thermal shock technique being the most efficient, economical and technically safe method of extracting wax, although it involves risks to infrastructures, spaces and, more seriously, to working operators as stated by (Chica et al., 2013).

In any dewaxing system, a heat source is needed to melt the wax from the mold for a convenient evacuation, as commented by (Sarojrani, et al., 2012). Richards (2003), explains that in the case of ceramic husk molds, since the thermal expansion of the wax is greater than that of the ceramic husk, direct heating of the entire volume of the wax would cause mechanical stresses in the critical areas of the husk (intersections with long surfaces) or critical defects (large particles or pores after the first coating) that would end up cracking the mold. The risk of cracking can be reduced by increasing the melting delay between the surface and the wax core taking advantage of the low thermal conductivity of the wax and the higher thermal conductivity of the husk when the ceramic mold is exposed to high temperatures (Druschitz, 2009).

Flash dewaxing consists of rising the ceramic mold temperature in an oven to a range between 600°C and 800°C to melt the outermost layer of wax and thus create a dilation joint between the solid wax model and the mold (Richards, 2003). Usually, the flame of a gas torch is used in the workshops of

artistic foundry to achieve the thermal impact, causing the loss of 2/3 of the wax by its violent combustion, and generating problems of emission of gases and fumes, with the consequent danger to the workers who carry out this operation.

Fig. 1 (left) shows a typical flash dewaxing oven operating at real conditions with gases emanating due to wax combustion. Fig. 1 (right) shows the specific microwave prototype that was used to carry out the tests presented in this work with a wax drainage system and a wax collector, gas extraction from inside the chamber, and power control.

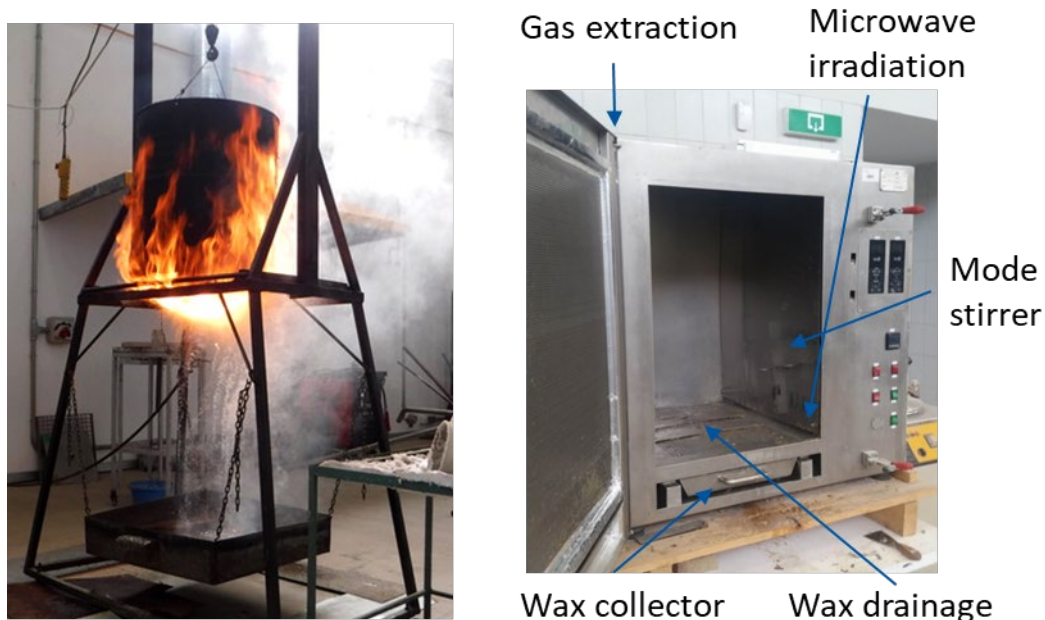

Fig. 1. Operation of a flash dewaxing system in a fine art workshop compared to the microwave-assisted prototype used in this work.

Unlike traditional heating, microwave heating is generated in the material itself, as long as its chemical composition allows it. The dielectric properties of the materials characterize these effects at a macroscopic level: the dielectric constant indicates the material capacity to store and distribute the electric field, while the loss factor is an indicator of how quickly you can heat it up. Another great advantage is the selective heating of microwaves: when materials with different loss factors are simultaneously heated, a differential heating will arise, the material that absorbs microwaves more rapidly being heated at higher rates, as stated in (Monzó et al., 2001).

Both the wax and the ceramic husk are materials with very low loss factors which means a very slow and inefficient microwave heating. Direct heating of the wax, moreover, would not prevent breakages in the mold due to their different thermal expansion coefficients. By coating the wax model with a layer of susceptors, which are materials with high microwave absorption capacity, it is possible to promote selective heating and accelerate the heating process making and, in addition, accentuate it initially in the outermost layer of the wax allowing to anticipate its melting and evacuation. This approach can generate a joint of expansion between the ceramic husk and the wax. The objective of this work is to evaluate the suitability of graphite and TiO_2 as susceptors in microwave-assisted dewaxing for small works of art used in artistic foundry.

Microwave dewaxing for investment casting applications has been previously studied in (Qayyum, et al., 2021) by using carbon-black-modified LDPE–paraffin wax composites. A different approach is patented in (Albaladejo et al., 2014) in which susceptors between ceramic husk and wax are proposed. Those susceptors force the preferential heating of the external area of the wax and create, under appropriate conditions, a dilatation joint that avoids mechanical stresses by the expansion of this material.

In (Yahaya et al., 2015) the lost wax method is tested in a modified household microwave oven in the 2.45 GHz band with a nominal microwave power of 700W, reducing the time of dewaxing by 40%. In this contribution the authors introduce up to 25% active carbon into the ceramic husk mixture, although cracks are detected when the proportion rises to 30%. This study also shows the low values of the loss factor of both the wax and the ceramic mold when they are not mixed with a susceptor and the importance of an adequate choice of the susceptors to be used in the wax-mold ceramic interface. In (Yahaya et al., 2016) the impact of the use of microwave susceptors on ceramic molds is studied, concluding that although the porosity and collapsibility of the mold improve, the strength of the mold and its density decrease.

The physic-chemical changes caused by microwave dewaxing in wax are evaluated in (J.B Brum, et al., 2009). In this work and in (Karunakar, 2013), it is concluded that microwave dewaxing generally causes less significant changes in the wax than those achieved by using conventional techniques such as autoclaving and that it incorporates less water and dirt to this material. The technical feasibility of microwave dewaxing is also demonstrated in those works. A recent review of the benefits of microwave-assisted dewaxing over the use of autoclave can be found at (Jayavabushana et al, 2020).

On the other hand, the susceptors are chemical substances that act as catalysts of the transduction of microwave energy into thermal energy, having a high value of dielectric and/or magnetic losses. In microwave-heating processes for the recovery of synthetic polymers, small additions of metallic powder or graphite have increased microwave absorption and thus increased temperature growing rates (Suriapparao and Vinu, 2015). Other studies show how the addition of carbonaceous materials can dramatically increase microwave heating in pyrolysis processes of urban waste (Beneroso et al., 2016).

The dielectric properties of some susceptors compatible with ceramic husk for frequencies close to 2.45 GHz are measured with different techniques in different studies. In (Fayos et al., 2018), the case of TiO_2 , the complex permittivity at that frequency is $\epsilon_{r\text{TiO}_2} = 4.28 - j 0.04$ at 30 °C while the complex permittivity of graphite varies with density when measured in powder format. At frequencies close to 2.45 GHz the dielectric constant of graphite can vary between 18 and 25, while the loss factor can vary between 10 and 13 for relative densities between 20.8 and 25.6%, respectively. Expressing these intervals in a complex way, therefore, $\epsilon_{r\text{graphite}} \in [18,25] - j [10,13]$ (Hotta et al., 2011). These dielectric loss values contrast with those found in (Yahaya et al., 2015) for colloidal silica stucco, which is the main component of the ceramic husk mould, $\epsilon_{r\text{stucco}} = 1.8 - j 0.0243$, and for wax $\epsilon_{r\text{wax}} = 2.53 - j 0.0034$. As it can be perceived from this data, the loss factor of TiO_2 is 10 times higher than that of wax while the loss factor of graphite is more than 3000 times higher. Therefore, both susceptors will heat up much faster than wax or stucco. Finally, in (Atwater and Wheeler, 2004) it is shown how the increase in temperature can cause the increase in the loss factor of graphite which could lead to a phenomenon of thermal avalanche and activate the so-called hot spots.

In this work we assess the use of TiO_2 and graphite, and a mixture of both materials as susceptors applied to the outer layer of the wax model for microwave-assisted dewaxing of ceramic shell molds. To create the susceptor layer, we always used a 50/50 suspension of susceptor and colloidal silica. This procedure allowed the susceptor layer to be mechanically connected to the external stucco layer and act as the internal part of the ceramic mould. The temperature distribution, the dewaxing quality in terms of ignitions, wax stoppers and mold cracks are studied versus the susceptor type and the applied microwave power levels. To the best authors' knowledge this is the first time that this procedure for microwave dewaxing of artwork ceramic shell molds is evaluated.

2. Materials and methods

In this work, we have followed the patented methodology proposed in (Albaladejo et al., 2014). Thus, the graphite or TiO_2 , or a mixture of both materials, were used as microwave susceptors and applied

directly to the outer part of the wax model. Figure 2 shows the scheme of a cross-section of a cup-shaped ceramic mold in which a layer of susceptor located between the wax model and the ceramic husk mold has been applied. When the piece is irradiated inside the microwave cavity, the microwaves pass through the ceramic shell, which has low losses and is therefore quite transparent to the microwaves and heat the susceptor. The susceptor heats up much faster than the ceramic husk and wax and transfers this energy to its surroundings by thermal conduction, causing the external wax of the model to melt very quickly, creating a dilatation joint. In this way, we try to reproduce the foundations of flash dewaxing by using microwaves.

The study presents two types of tests. On the one hand, the thermal behavior of the materials subjected to microwave radiation in our study is analyzed using samples modeled in the form of plates and applying susceptor layers to them. On the other hand, the evaluation of the microwave dewaxing is carried out by using cup-shaped samples. In this last case, the most suitable susceptor is applied to all samples to reproduce the flash dewaxing technique by means of microwave irradiation and to evaluate whether the obtained results are similar to those generated with the traditional system or not. The susceptor components employed in this study include Hispasil colloidal silica with a particle size of 7 nm and various concentrations, 248576 Sigma-Aldrich TiO₂ powder with a purity greater than 99 percent and -325 mesh size, and 282863 Sigma-Aldrich synthetic graphite powder with a particle size lower than 20 μm.

2.1. Manufacture of plate samples

Figure 3 shows a scheme of the ceramic husk plates used in the thermal tests of the susceptors. They were manufactured from rectangular wax blocks with dimensions 6 x 2 x 0.3 cm³. Three batches of 26 ceramic husk plates were made. Each plate was formed by alternating layers of a Moloquita barbotine into flour (-200) and Hispasil colloidal silica (7 nm) at 30 % in its aqueous base brushed and battered with fine-grained Moloquita aggregate (50/80). In total, 3 layers of barbotine and their respective batter were used. The proportions in the composition of the barbotine, between the refractory material (Moloquita) and the binding substance (colloidal silica), for each layer were variable: 70% and 30%, respectively, for the first layer, 60% and 40% for the second, and 50% and 50% for the last layer. Each piece was dewaxed in the traditional dewaxing hood obtaining the plates as trays of ceramic husk already without wax. The ceramic husk produced by this process was sintered by applying a flame torch technique with temperatures exceeding 700°C for 5 minutes and was, therefore, moisture-free. After the sintering, a susceptor layer was applied to each batch on the surface of the ceramic husk as follows:

- Batch 1: 26 plates with 50% Graphite and 50% colloidal silica.
- Batch 2: 26 plates with 50% TiO₂ and 50% colloidal silica.
- Batch 3: 26 plates with 25% Graphite, 25% TiO₂ and 50% colloidal silica.

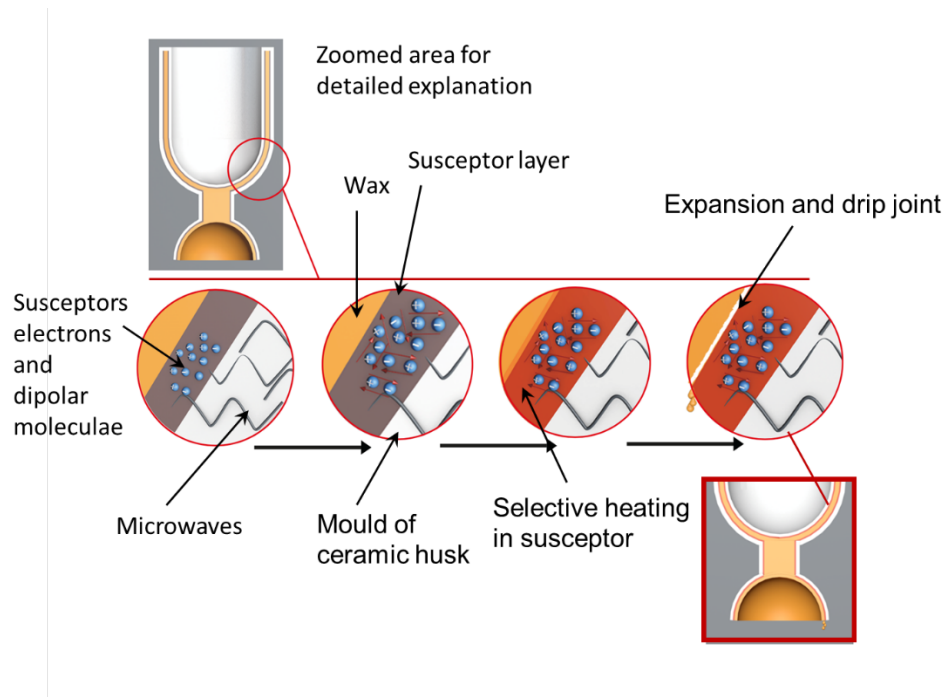

Fig. 2. Mechanism of microwave energy absorption in a susceptor applied to the external area of an artistic model made of wax

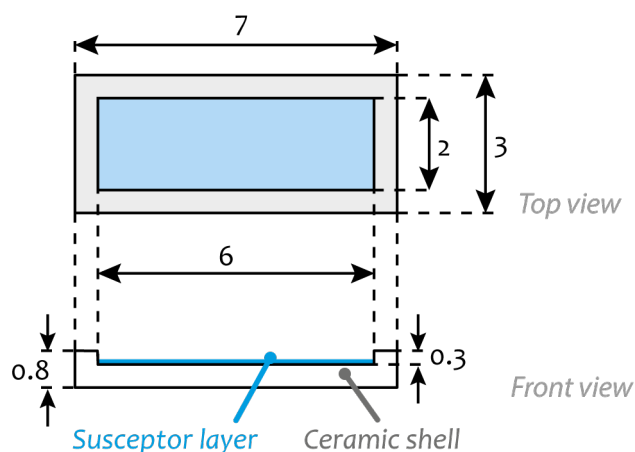

Fig. 3. Diagram and dimensions of plate-type samples. All dimensions in cm.

2.2. Manufacture of cup-shaped samples

Figure 4 shows a scheme of a cup-shaped sample that correspond to a standard form sculpture. Models made of wax with and without applied susceptor are also shown in Fig. 4. As a core material, a mixture commonly used in artistic foundry workshops was used. This mixture was composed of 70% virgin beeswax, 20% paraffin and 10% rosin. Eighty-eight cup-shaped pieces were made with only a 4 mm irrigation duct with a circular section placed at the highest point of its curvature and its corresponding crucible. The dome occupied $6 \times 4 \times 4 \text{ cm}^3$. The wax mould was made by heating the wax until it became liquid, then pouring it into a 3D-printed plastic container until it was completely filled. The wax was then cooled until it solidified again. Because the temperature of the wax was not controlled during the process, several liquid wax densities were poured into the plastic mould, resulting in a variety of weights for the various wax models. As a result, the waxy pieces weighed between 57 and 98 g. Once the wax model was formed, a layer of shellac to the brush as adherent and a layer of susceptor composed of 25% graphite, 25% TiO_2 and 50% colloidal silica were applied.

Once the susceptor has been applied, and after the 15 minutes necessary for drying, the refractory mold was formed, without modifying the usual procedure so that its characteristics were not altered and, therefore, it did not influence the subsequent results for metal casting. The same protocol is therefore followed as described in the preparation of the plate-type samples, with a 4-hour drying cycle between each layer at a 45 % ambient relative humidity index.

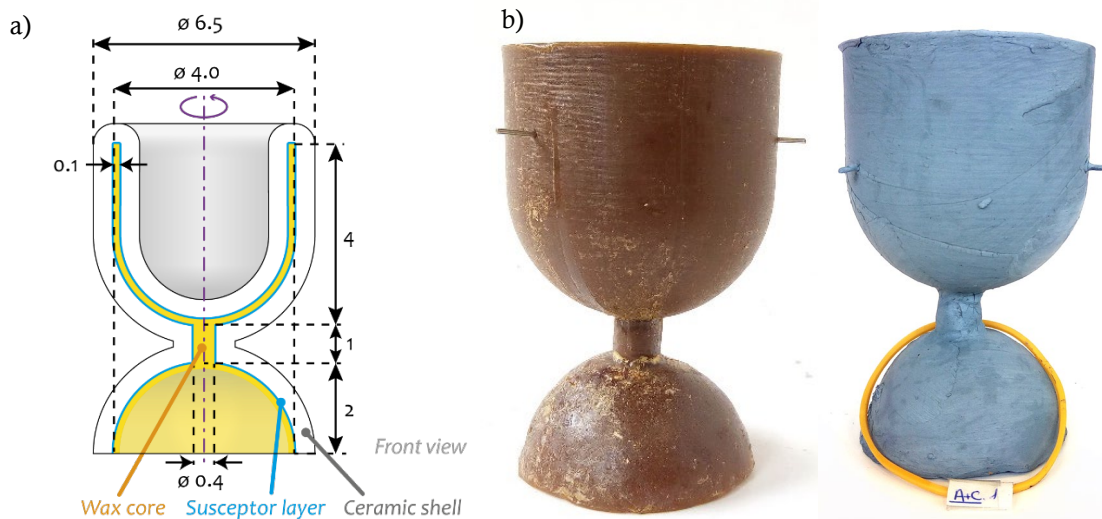

Fig. 4. a) Scheme of cup-shaped samples and b) model of the piece in wax (left) and with the susceptor layer applied (right) in inverted position for drainage. Dimensions in cm.

2.3. Instruments and methods

For the microwave irradiation of the plate samples, we used a microwave oven from the manufacturer Menumaster Commercial (model RCS511TS). Its 2,45 GHz magnetron had a maximum rated power of 1100 W and the cavity of 21,6 x 36,8 x 38,1 cm³ used an electromagnetic mode stirrer to improve the homogeneity of the electric field. These samples were exposed to 1100 W microwave levels for 10 seconds to understand the thermal behavior of the susceptors. We measured the temperature increase for each sample and the statistical dispersion of the heating in each batch by recording the temperature before and after the process.

For the dewaxing tests of cup-shaped samples, we used the prototype microwave oven shown in Figure 2 that was specifically designed for the dewaxing of small and medium artwork models. This microwave applicator has a 76 x 60 x 60 cm³ cavity and can irradiate a maximum microwave power level of 2200 W with 2 independent magnetrons at a frequency of 2,45 GHz. An electromagnetic metallic mode stirrer was used in order to obtain a more uniform microwave heating pattern. The wax was recovered in a metallic tray through a heated metallic grid as described in (Albaladejo et al., 2014).

The success of microwave dewaxing is based on the effectiveness of thermal shock that should lead to:

- the achievement of minimal fissures detected by visual inspection,
- a homogeneous temperature pattern that should avoid localized overheating or hot spots
- absence of ignition,
- and reduced times for the total removal of the wax.

All these aspects were studied for the dewaxing process of cup-shaped samples.

The effectiveness and quality of the microwave thermal shock was studied by performing a total of 60 tests with cup-shaped samples with 3 irradiation power profiles (20 samples at 1100 W irradiated for 1 minute, 20 samples at 2200 W processed for 1 minute, and 20 samples at 2200 W dewaxed for 40 seconds). At the end of each test, the corresponding thermographic image and temperature were recorded.

Both plate and cup-shaped samples were individually placed inside their respective microwave applicators on the same reference point located in the center of the cavity floor to minimize divergence of results due to location variability. For the collection of thermal data, a Fluke F-62 MAX+ infrared thermometer was used. This thermometer provided the average temperature value at the central areas of both types of samples. Fig. 5 shows both the sample position in the different microwave applicators during the heating and dewaxing tests and the measured area of the infrared thermometer. Thus, we assumed that those temperatures were representative values of the thermal results after processing. For the qualitative study of the hot spots in the cup-shaped samples the Fluke TiS20 thermographic camera was used, recording a surface temperature distribution profile per sample.

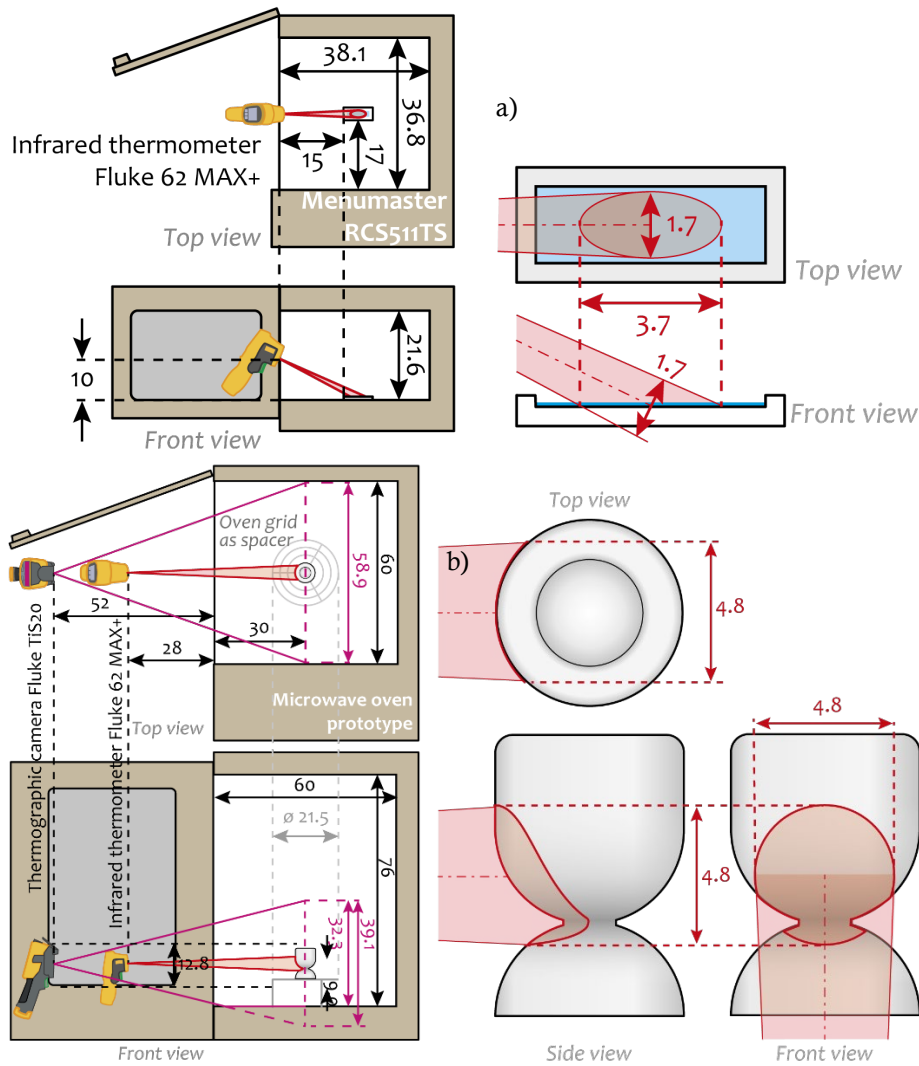

Fig. 5. Experimental setup for the recording of thermal data: a) rectangular plates and b) cup-shaped test pieces. Dimensions in cm.

3. Results

The results of the surface temperature recorded in the susceptor layer of each of the processed plate samples are shown in Figure 6. The average temperature and standard deviation of all sample plates irradiated at 1100W power levels during 10s are detailed in the figure. It is observed that TiO_2 shows a warming rate too low but consistent temperature values because of its dielectric properties (Fayos et al., 2018), while graphite has a higher heating rate but more divergent temperature measurements, being the extreme values recorded in the latter case 147°C and 290°C.

In fact, about 80% of the samples in which only graphite was used as a susceptor had micro-ignitions in the first few seconds of the test, qualifying the process as unstable and at risk of damage. Finally, the combination of TiO₂ and graphite in equal parts increased the average temperature and improved repeatability, justifying this composition as the most suitable as susceptor. This combination produced stable temperatures as well as non-ignition processes. Ignitions with this type of susceptor were not observed because, at least at this temperature range, the thermal avalanche process does not occur when TiO₂ and graphite are mixed, as it does when graphite is used exclusively as a susceptor.

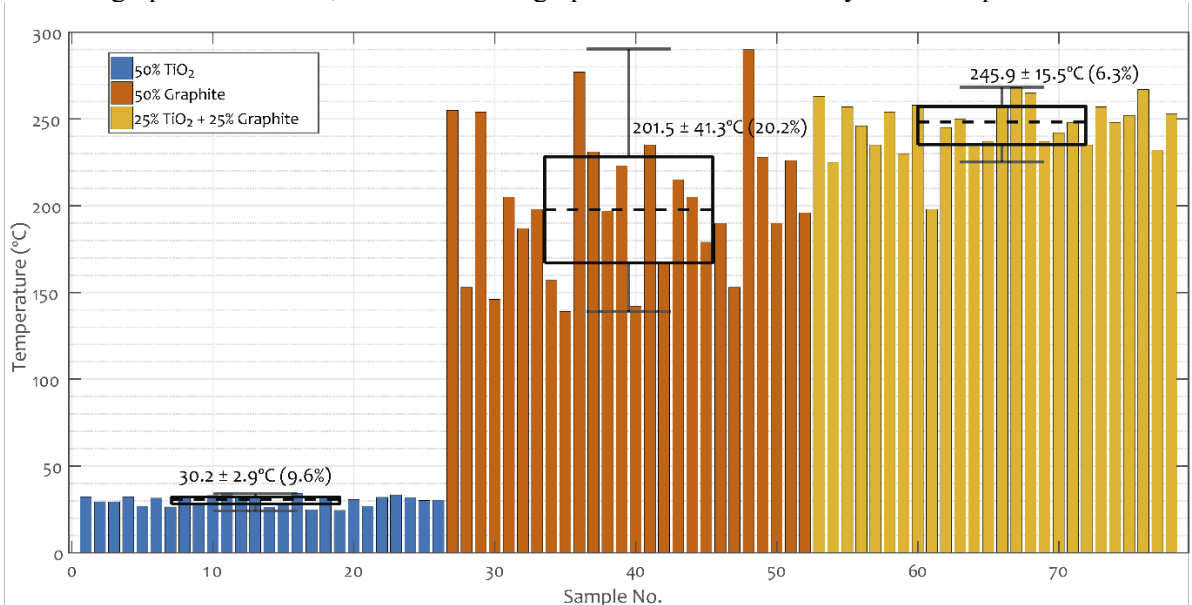

Fig. 6. Susceptor layer temperature records for plate samples in each test after 10 s irradiated at 1100W.

For the tests carried out on the cup-shaped samples, Fig. 7 presents the qualitative analysis of the first 60 samples classified by the type of irradiation profile and ordered according to their recorded temperature. In Fig. 7, samples are marked with a potentially acceptable processing: those that do not present irreversible damage such as cracks or ignitions. Cracks appeared in the convex areas of the samples in all cases due to wax plugs. It should be noted that solid wax plugs are shown in Fig. 7 when they are visible from the bottom of the cup-shaped samples, but when cracks appear, they are caused by internal wax plugs even when they are not visible. From obtained results it can be observed that employing higher energy and power levels (132 kJ, 2200 W) avoided the appearance of solid wax pluggings although promoted ignitions in the process. For low power levels (1100 W) crackings appeared very frequently because no dilation joint was created during the process. Finally, most of samples achieving a surface temperature higher than 200 °C almost completely eliminated wax pluggings indicating a threshold temperature for the microwave dewaxing process.

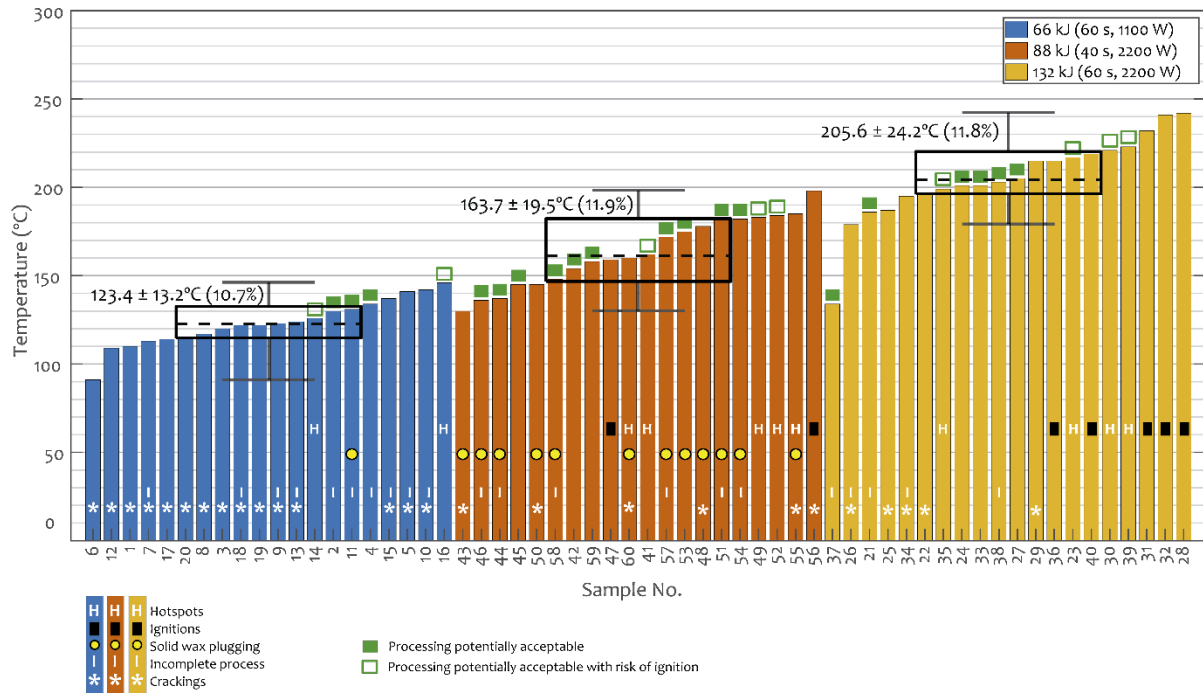

Fig. 7. Qualitative analysis and surface temperature of cup-shaped samples after processing with different irradiation profiles.

Figure 8 shows a summary of the problems encountered depending on the microwave application regime for cup-shaped samples. It can be observed that an insufficient microwave power (1100 W) leads to the appearance of cracks because the external wax of the model does not melt fast enough to generate a dilatation space. In fact, when using just 1100 W during 60 s, 75% of the samples showed cracks. However, this percentage decreased to 30% and 25% when using 2200 W to achieve 88 kJ and 132 kJ irradiated energy levels, respectively.

Likewise, low powers do not get the complete dewaxing of the parts to a large extent. For samples irradiated at 66 kJ energy levels the percentage of incomplete dewaxing tests was 50%. For energy levels of 88 kJ and 132 kJ, however, these percentages were 30% and 25%, respectively. This indicates that a minimum energy level is required so that the susceptor completely melts the wax by thermal irradiation.

Wax stoppers can be avoided too when the power levels are high enough and are applied for long enough since the susceptor is able to provide a thermal radiation that melts the excess wax inside the model. In fact, 132 kJ tests show no wax stoppers at all. In this way, both heating uniformity and power levels are of utmost importance to avoid wax stoppers. However, the irradiation with too much power allows the appearance of ignitions in the ceramic husk and the appearance of hotspots. Tests carried out at 132 kJ showed 25% of ignitions whereas this percentage diminished to 10% in the case of samples irradiated at 88 kJ microwave energy levels.

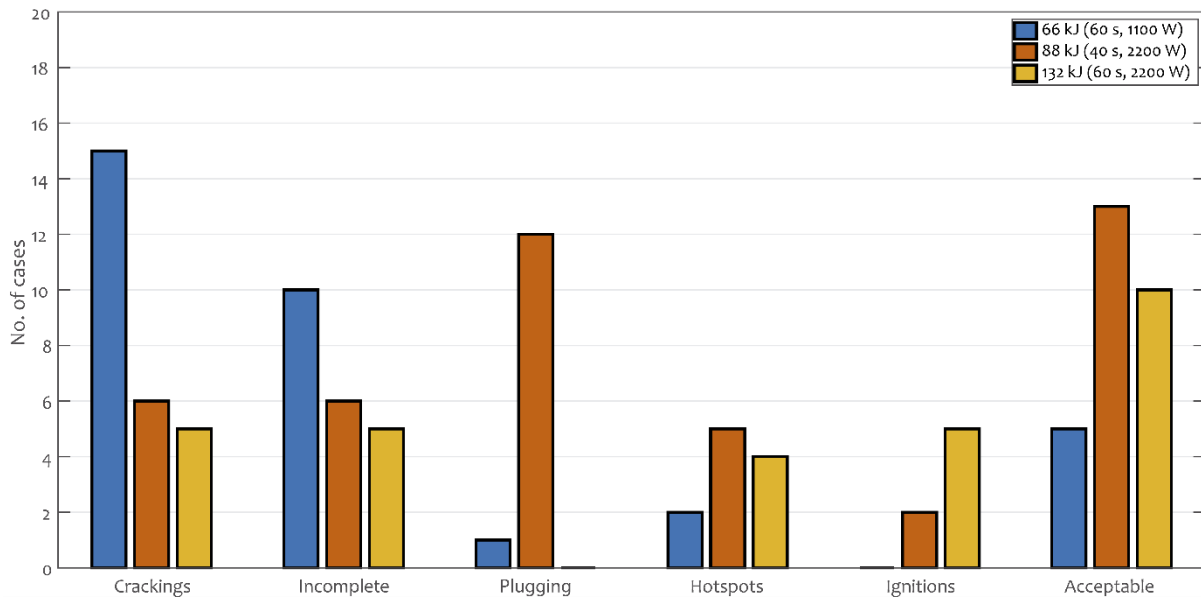

Fig. 8. Summary of qualitative results of cup-shaped samples processed according to three levels of irradiated power and energy.

Therefore, in the tests carried out for cup-shaped samples, the use of 2200 W for 40 and 60 seconds provided the best results, being slightly better the regime of 40 s/2200 W although it presented a greater number of wax stoppers. The results of this microwave dewaxing process indicate that at least an average power density of 77,5 W per gram of wax is necessary to completely dewax the cup-shaped samples.

Figure 9 shows thermographies of cup-shaped samples number 72 and 78, irradiated at 138 kJ, just after the microwave dewaxing. It can be observed that although the average temperature is close to 80°C (melting temperature of the wax) in some points this temperature is not reached and in others hot points are observed with temperatures up to 155 °C. Therefore, one of the main drawbacks of this dewaxing technique seems to be, at least in this case, the lack of homogeneity of heating and the appearance of ignitions or wax stoppers due to insufficient heating in different areas of the test piece. This lack of heating homogeneity, however, could be overcome by the introduction of techniques such as sample movement, electronic control of irradiation patterns with solid generators or the improvement of the mode stirrers.

Finally, in Figure 10 different photographs of cup-shaped samples dewaxed with microwaves can be observed. Colloidal silica stucco is a porous material that allows fire and smoke from susceptor layer ignitions to pass through. In fact, if an ignition occurred while performing microwave dewaxing, the flame could sometimes be seen. Consequently, in the cases in which ignitions are produced it can be noticed that the ceramic husk appears with a darkened color by the combustion of the susceptor and the stucco itself. However, the microwave dewaxing technique was also able to evacuate the wax without producing these ignitions as shown in this figure.

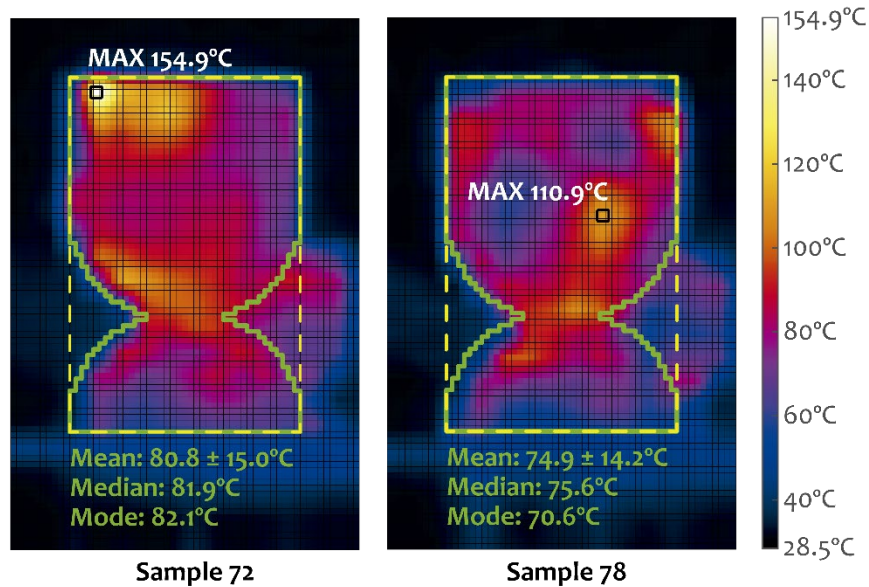

Fig. 9. Thermographs 72 and 78 in linear scale after microwave-assisted dewaxing.



Fig. 10. Photographic record of the successful microwave dewaxing for sample 82 (left), and example of ignition for sample 63 (right).

4. Discussion and conclusions

In this work, the application of TiO₂ and graphite as susceptors in the microwave dewaxing of art molds has been evaluated. The obtained results indicate that the technique is viable although the choice of the susceptor, the power and the time of irradiation turn out to be fundamental.

The experimental tests demonstrate that the application on the wax mold of a susceptor composed of the mixture with proportion of 25% graphite (282863 Sigma-Aldrich), 25% titanium oxide TiO₂ (248576 Sigma-Aldrich) and 50% colloidal silica Hispasil (7nm) (A+C) manages to dewax pieces of ceramic husk with a recovery of more than 90% wax, by avoiding its combustion.

The cracks detected in some samples are a symptom of thermal shock failure. This happens especially with lower irradiation power levels (1100 W for 60 seconds, 66 kJ), which are not fast enough to create a dilation joint, causing 75% of the samples to crack. The other power profiles, which provide more energy (2200 W, 88 kJ and 132 kJ), reduce cracking cases to 30% and 25% respectively. In order to avoid the appearance of cracks, it is equally important that the thermal shock be successful, as a priority,

in the lower evacuation zone, so that the liquid wax can be properly drained. The 132 kJ profile has no case of wax stoppers, while the 88 kJ profile produced 60% wax stoppers. The disadvantage of the 132 kJ profile, however, is that its ignition rate is 25%, while in the 88 kJ tests this percentage is reduced to 10%.

An important issue is the existence of solid wax, therefore, cold, in the lower evacuation area due to the lack of uniformity of heating in some tests as shown in Figure 9. This causes cracking due to inability to expel the melted wax. The increase of the power and, therefore, of the temperature, achieves better results, but it is also true that it is observed that once exposed a minute to 2200W, there is an index of 45% of "hot spots", of which 11.11% show even ignition of the wax, revealing flame.

To solve this problem, therefore, a much more uniform heating must be achieved in all parts of the pieces or a progressive heating, starting from the evacuation zone and ending in the area furthest from the evacuation. In order to achieve this improvement in the uniformity of heating, the test piece being heated could be rotated or an electronic control of the heating by means of solid state technology and the monitoring of the distribution of the surface temperature. Power control could also prevent ignition if combined with temperature monitoring in the sample.

Bearing in mind that one of the objectives is to avoid the combustion of the wax and, consequently, the total recovery of the wax, the temperature of the test piece must not exceed 150 °C during the first minute of the process, since it begins to experience excessive overheating that evidences a heterogeneous thermal process. Therefore, with the currently used microwave oven it is determined that, if we apply a higher power, the temperature increase will occur mainly in the hot spots causing the susceptor to burn and, consequently, also the wax.

The use of graphite and TiO₂ mixtures, although it can generate a significant thermal shock, also causes the appearance of hot spots that can be due to differences in density in the manual application (Hotta et al., 2011) or by avalanche of temperature (Atwater and Wheeler, 2004). Therefore, it seems necessary to find a susceptor that, although it has a good microwave absorption, similar to that of graphite, lowers or maintains its loss factor with increasing temperatures, which would prevent the thermal avalanche.

A very relevant fact is that the wax that forms the conduit through which the metal flows becomes in the process of dewaxing in a real solid stopper at the exit when the temperature is not high enough. Therefore, it seems important to heat this conduit preferentially since this mass of cold wax prevents the rest of the wax from leaving. If this preferential heating is not achieved, even if the thermal shock is successfully caused and the expansion joint is propitiated, the drip has nowhere to go and ends up breaking the mold. It is therefore essential that this mass is melted as soon as possible.

In fact it is decisive that 73.3% of the cases in which there have been no cracks, turn out to have opened totally or partially the exit conduit. This implies that there has been a sufficient increase in temperature to melt this area in the first moments of the process. A possible improvement, therefore, could be to apply a double layer of susceptor on the surfaces intended to be escape routes of the melted wax to prioritize heating in those areas and to apply less susceptor on edges and vertices, where there is usually a greater electric field intensity, to avoid hotpots.

The application of the susceptor to the outer part of the wax model makes the technique feasible, by absorbing the microwaves in a controlled area, thus raising its temperature on the surface of contact with the wax, so that it can be evacuated. To do this, the heating of the plastered surface must be as homogeneous as possible so that the expansion joint is regularly generated, fact that has only been partially achieved in this work.

Thus, as possible improvement measures, we propose:

- Including the rotation of the samples to achieve greater uniformity of heating.
- Applying susceptors with less propensity to thermal avalanche.

- Combining the use of microwave with hot gas to uniformize and enhance thermal shock on the outer surface of the wax.
- Applying greater amount of susceptor in the escape routes to increase the heating in those areas and avoid wax plugs.

Further research is envisaged in this direction.

5. References

- Albaladejo González, J. C., Monzó Cabrera, J., Clemente Fernández, F. J., Fayos Fernández, J., & Lozano Guerrero, A. J. (2014). *Patent n° ES2519990 A1*.
- Atwater, J., & Wheeler, R. (2004). Temperature dependent complex permittivities of graphitized carbon blacks at microwave frequencies between 0.2 and 26 GHz. *Journal of Materials Science*, 39, 151–157. DOI: 10.1023 / B: JMISC.0000007739.07797.08.
- Beneroso, D., Albero, O., Monzó, C., Díaz, M., Arenillas, A., & Menéndez, J. (2016). Dielectric characterization of biodegradable wastes during pyrolysis. *Fuel*, 172, Pages 146-152. <https://doi.org/10.1016/j.fuel>.
- Chica, E., Agudelo, S., & Sierra, N. (2013). *Lost wax casting process of the runner of a propeller turbine for small hydroelectric power plants*. *Renewable Energy*, Volume 60.
- Davey, C. J. (2009). *The early history of lost-wax casting, Metallurgy and Civilisation: Eurasia and Beyond*. London: Archetype.
- Druschitz, E. A. (2009). Investment Shell Cracking, MsC. Thesis, Missouri University of Science and Technology.
- Fayos, F., Pérez, C., Monzó, C., Pino, S., & Albaladejo, G. J. (2018). Temperature-dependent complex permittivity of several electromagnetic susceptors at 2.45 GHz. 95, 2-8. Delft: AMPERE Newsletter Editor. Available online <https://www.ampereurope.org/issue-95/>.
- Hotta, M., Hayashi, M., Lanagan, M. T., Agrawal, D. K., & Nagata, K. (2011). Complex Permittivity of Graphite, Carbon Black and Coal Powders in the Ranges of X-band Frequencies (8.2 to 12.4 GHz) and between 1 and 10 GHz. *ISIJ International*, 51, 1766–1772.
- J.B Brum, F., Vedana, I., C. Amico, S., & Spim JR, J. (2009). Microwave dewaxing applied to the investment casting process. *Journal of Materials Processing Technology*(209), 3166-3171.
- Jayavabushana, V., Shashank, K., Venkatesh, & Gayathri, R. (2020). Analysis of microwave dewaxing and its advantages over conventional autoclave dewaxing. *European Journal of Molecular & Clinical Medicine*, 1668-1672.
- Karunakar, D. R. (2013). Recycling of Pattern Wax In The Investment Casting Process Using Microwave Dewaxing. *IOSR Journal of Engineering*, 3, 05-10.
- Monzó, C., Díaz, M., Catalá, C., & Reyes, E. D. I. (2001). Effect of dielectric properties on moisture leveling in microwave-assisted drying of laminar materials. *Microwave Opt. Technol. Lett*, Vol 30(3), 165–168.
- Qayyum, G. Y., Farhan, S., Haroon, S. M., Shafiq, I. M., & Umer, A. (2021). Study on the Dewaxing Behavior of Carbon-Black-Modified LDPE–Paraffin Wax Composites for Investment Casting Applications. *Arabian Journal for Science and Engineering*. *Arab J Sci Eng*, 7, <https://doi.org/10.1007/s13369-021-05406-z>.
- Richards, V. L. (2003). Final Report: Investment casting Shell cracking. University of Missouri.
- Sarojrani, P., Karunakar, D. B., & Jha, P. (2012). Developments in investment casting process—A review, *Journal of Materials Processing Technology*. *Journal of Materials Processing Technology*, Vol. 212(11), pp. 2332-2348.
- Sias, F. (2005). *Lost-wax casting: old, new, and inexpensive methods*. Pendelton: Woodsmere Press.
- Suriapparao, D. V., & Vinu, R. (2015). Resource recovery from synthetic polymers via microwave pyrolysis using different susceptors. (113), 701-712.

- Yahaya, B., Izman, S., Idris, M. H., & Dambatta, M. S. (2015). Effects of Activated Charcoal on Dewaxing Time in Microwave Hybrid Heating. *Procedia CIRP*, 26, 467–472. <https://doi.org/10.1016/J.PROCIR.2014.07.039>.
- Yahaya, B., Izman, S., Idris, M. H., & Dambatta, M. S. (2016). Effects of activated charcoal on physical and mechanical properties of microwave dewaxed investment casting molds. *CIRP Journal of Manufacturing Science and Technology*, 13, 97–103.

Acknowledgements

This work is funded by the State Program for the Promotion of Scientific and Technical Research of Excellence around two projects in this line "Alternatives to dewaxing in the smelting of ceramic husks (ceramic shell casting): microwave technique", HAR2010-17570 (01/01/2011 - 30/04/2014) and "Alternatives to dewaxing in ceramic husks (ceramic shell casting): Microwave technique (II)", reference. HAR2016-77203-P (30/12/2016 - 29/12/2019).