



GLOBAL JOURNAL OF COMPUTER SCIENCE AND TECHNOLOGY: G
INTERDISCIPLINARY

Volume 23 Issue 1 Version 1.0 Year 2023

Type: Double Blind Peer Reviewed International Research Journal

Publisher: Global Journals

Online ISSN: 0975-4172 & Print ISSN: 0975-4350

Data Visualization as a Means of Optimizing Control Systems Model in Project Management

By Amirali Kerimovs

Annotation- The article addresses current issues concerning the utilization of data visualization in project management within the project context. It delves into the characteristics and principles of implementing projects within the project management framework of business entities. The classification of processes within the project management system is outlined. The study examines the significance of data visualization as a prerequisite for decision-making, highlighting the traits of visual project management. The tools employed for crafting visual representations of project data, derived from project implementation outcomes, are investigated. Various types of infographics intended for monitoring the execution of project-related business tasks, encompassing factors such as sequence, resources, and commencement and culmination dates, are identified. The article concludes by presenting the outcomes of generating visualizations using MS Project and MS Power BI within the realm of project management business processes in the project area.

Keywords: software engineering, project management, project data, visualization, project management, project scope, dashboard.

GJCST-G Classification: ACM Code: D.2.8



Strictly as per the compliance and regulations of:



© 2023. Amirali Kerimovs. This research/review article is distributed under the terms of the Attribution-NonCommercial-NoDerivatives 4.0 International (CC BYNCND 4.0). You must give appropriate credit to authors and reference this article if parts of the article are reproduced in any manner. Applicable licensing terms are at <https://creativecommons.org/licenses/by-nc-nd/4.0/>.

Data Visualization as a Means of Optimizing Control Systems Model in Project Management

Amirali Kerimovs

Annotation- The article addresses current issues concerning the utilization of data visualization in project management within the project context. It delves into the characteristics and principles of implementing projects within the project management framework of business entities. The classification of processes within the project management system is outlined. The study examines the significance of data visualization as a prerequisite for decision-making, highlighting the traits of visual project management. The tools employed for crafting visual representations of project data, derived from project implementation outcomes, are investigated. Various types of infographics intended for monitoring the execution of project-related business tasks, encompassing factors such as sequence, resources, and commencement and culmination dates, are identified. The article concludes by presenting the outcomes of generating visualizations using MS Project and MS Power BI within the realm of project management business processes in the project area.

Keywords: software engineering, project management, project data, visualization, project management, project scope, dashboard.

I. INTRODUCTION

Project management decision-makers rely on their own professionalism, critical thinking skills, experience, and subjective awareness of the generalized presentation of information, particularly concerning project management outcomes, which is facilitated through data visualization.

II. LITERATURE REVIEW

The digitization of various aspects of enterprise operations, particularly in the realm of project management, involves the creation of visualizations based on project data. A project, defined as a temporary endeavor aimed at producing a unique product, service, or outcome, serves as a means to directly or indirectly achieve the organization's strategic objectives [8]. According to the official state portal that registers social and economic development projects in state financed by international project organizations [7], the funding for projects in the design domain constitutes 10.88% (pertaining to design and insurance activities) of the overall volume. These projects focus on enhancing project-related activities within business entities, implementing solutions and technologies in the broader project sphere, encompassing both the general project field and the FinTech sector. Project developments within the design sphere align with the Strategy for the Development of Design Sector until 2025 [2], which

outlines five strategic directions: project stability, macroeconomic development, project inclusivity, project market development, and innovative advancement. Under the innovative development direction, the development of the digital economy is emphasized, with metrics encompassing the advancement and utilization of cloud technologies, IT infrastructure development, and the proliferation of paperless technologies.

Project management entails the application of knowledge, skills, tools, and methods to project activities to meet defined requirements, necessitating effective process governance [8]. Modern project management principles [6], shown in Fig. 1, emphasize strategic project management, aligning with the broader strategic business goals. Project management is perceived as a business process, within which responsible individuals make crucial business decisions.

Author: Independent Researcher, Riga, Latvia.
e-mail: kerimovsoftdev@gmail.com

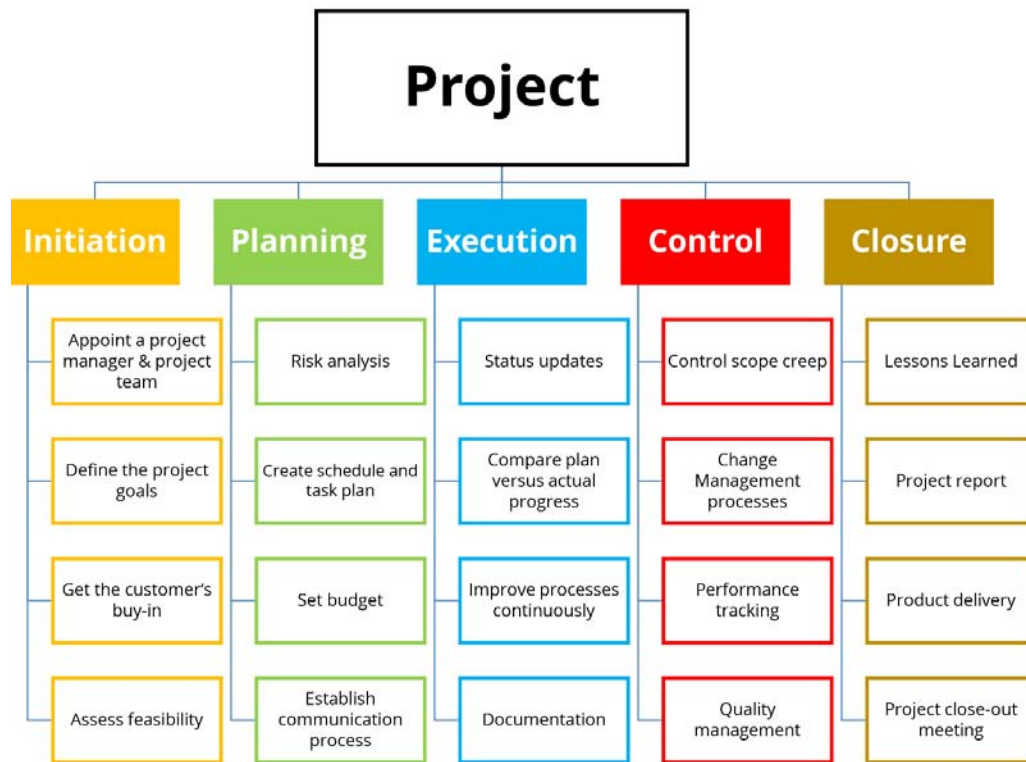

Fig. 1: Principles of Task Implementation in the Project Management System [3]

From an expert perspective, project management enables the creation of desired business advantages and enhances business value. Consequently, priority is given to projects that offer enduring benefits to the economic entity, with their managers executing strategic tasks that drive sustainable competitive advantage and foster growth in project performance indicators. In this context, project management transforms into a strategic competency for decision-makers, integral to their career progression, rather than a standalone milestone.

The execution of projects by business entities within the project domain constitutes a key phase in implementing their development strategies, comprising various business processes of differing durations.

Project progress in the project domain hinges on the effective execution of assigned tasks by project implementers. Among the primary tasks in project management [1] are project integration management, project scope management, project time management, project cost management, project quality management, project resource management, communication management, and project risk management. Project management encompasses methods for budget management, task sequencing, stage breakdown, and more. The project management process necessitates meticulous planning and monitoring, entailing a comprehensive understanding of all participants and the tasks they're responsible for.

The classification of processes within the project management system, according to the British standard Guide to the Project Management Body of Knowledge (PMBOK Guide) [8], is depicted in Fig. 2.

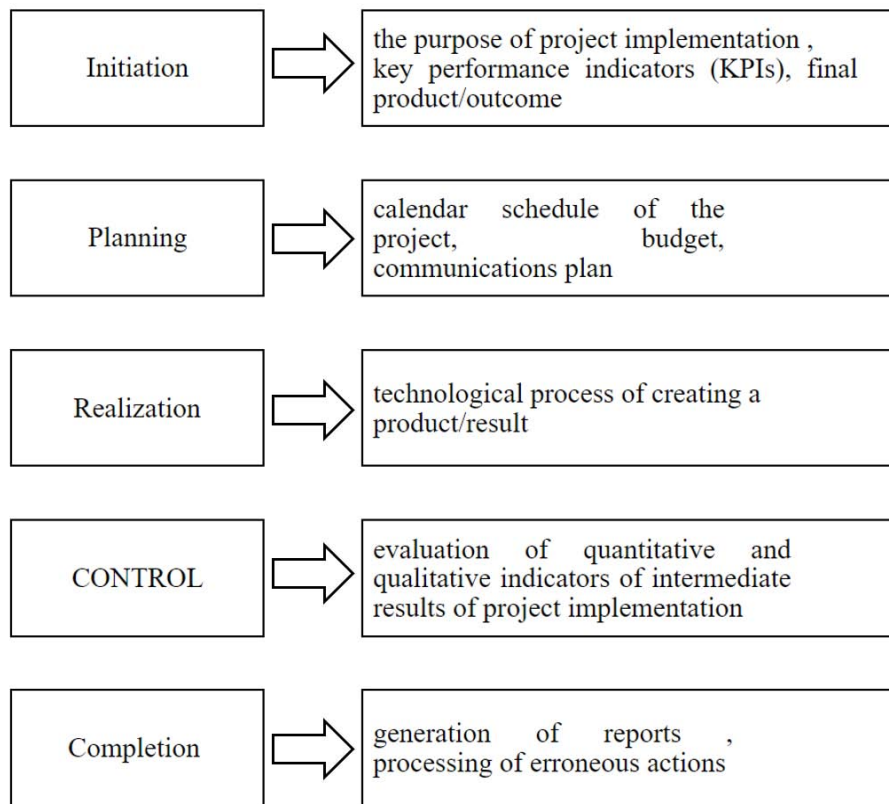

Fig. 2: Project Management Processes [8]

Establishing this interconnected process system underscores the integral role of the project component in each, with project indicators indicating feasibility, effectiveness, initiation, planning, and control of the ultimate outcome. Consequently, financial considerations emerge as a crucial criterion for evaluating the management effectiveness of projects within the project domain and other areas.

Efficiently coordinating the timely execution of numerous project tasks in the project domain demands significant resource allocation. Hence, in the context of the digital economy, employing tools that facilitate effective visualization and subsequent organization of tasks within the project activity sphere of a business entity has become pertinent.

The literature delves into the fundamental context and significance of GABP neural network recognition technology, highlighting its burgeoning research applications in relevant fields [10]. It elucidates both domestic and international trends in research applications, centering on systems like LPR and their real-world development trajectories in related domains. The primary focus of the literature centers on a detection model founded upon the integrated gray-scale GABP neural network model [11]. A comprehensive exploration ensues, encompassing aspects such as edge localization through electronic algorithms within gray-scale contextual images, wavelet transform detection

techniques, color image segmentation algorithms, analysis of texture-based gray-scale object images, and modern mathematical image morphology-based edge detection algorithms. Notably, the pivotal experimentation in this study employs the Roberts edge detection operator algorithm, directly applied to grayscale image edge detection [12].

Detailed insights into the software experimental environment are provided, encompassing the experimental software platform, processor, installation package, memory specifications, software runner, operating system, and the requisite software platform for the experiment. Through software examples and videos, the paper methodically elucidates the software's specific process and application procedure for the system experiment [9].

Drawing from the operational requisites of local taxation agencies within a specific city, the literature sequentially designs and scrutinizes the business process of the city's local taxation departments, followed by an analysis of business functions within the devised management system that cater to actual demands [5]. Employing both the company's technological assets and national key construction project management expertise as a research foundation, the literature synthesizes business requirements, research outcomes, and analytical findings into a comprehensive system design [2]. The integration of Java, MySQL, and other

technologies facilitate experimentation on the core modules of the entire system. The resulting test outcomes affirm the alignment of the designed national key project management system with current enterprise needs, characterized by its systematic nature, robust performance, intuitive interface, and operational convenience [1].

Data visualization encompasses the graphical representation of information, serving both to interpret and discern data essence, as well as facilitate communication [4]. Visualizations of design data not only allow for an analysis of design indicators but also provide a holistic depiction of the enterprise's design status. This aids in comprehending the situation and guiding further management actions. In essence, visualizations assist in identifying critical junctures within dynamically evolving project tasks within the project domain.

III. THE PURPOSE OF THE ARTICLE

The aim of this article is to empirically implement approaches to project management within the project context using tools for visualizing project data.

VI. PRESENTATION OF THE MAIN MATERIAL

Visual project management extends beyond the conventional task list, offering an organized approach to project execution and oversight [3]. This

methodology leverages visual representation to communicate project progress across various dimensions. Visual project management encompasses showcasing ongoing tasks, target completion dates, pivotal milestones, and other relevant project aspects.

In project management, the planning processes serve to establish the project's overall scope, define objectives, sequence activities, devise a project plan, and generate implementation-related documentation [8]. These documents comprehensively detail content, timelines, resources, and other pertinent facets.

A prominent technique for visualizing project processes is the Gantt chart [3]. This tool visualizes project stages, outlining the scheduled sequence of individual tasks and their respective timeframes. Chronologically breaking down the project facilitates effective allocation by decision-makers, enabling them to discern relationships among all components involved in the management process. The Gantt chart, resembling a visual bar chart, provides insights into task initiation, duration, and completion percentage. Through project data visualization, resource management, budget tracking, error monitoring, quick navigation, and adaptability to project changes are facilitated.

Fig. 3 depicts the visualization of project stages within the project area, targeting the implementation of project leasing operations within a business entity. This visual representation allows for monitoring project tasks concerning involved specialists and their work schedules.

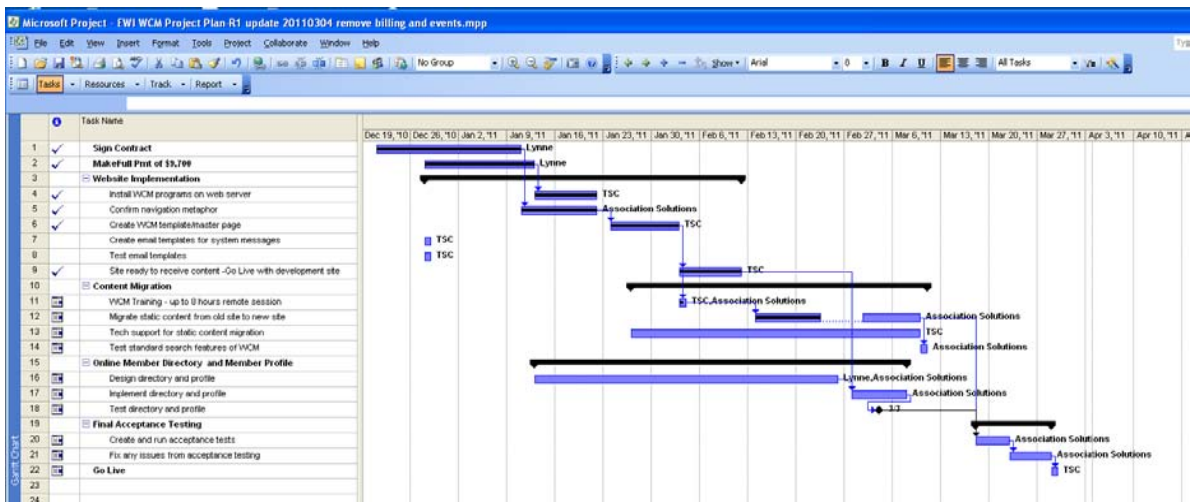

Fig. 3: Visualization of the Work Planning Results for the "Implementation of Project Leasing Operations in the Enterprise" Project in the Microsoft Project Environment (Fragment)

Within the project management framework, the manager conducts an analysis of resource expenditure for project implementation, evaluates the implications of risk exposure, and considers associated costs (such as enhancing working conditions, personnel training related to business processes, etc.).

Tracking the project's progress within the project domain, including the interdependencies among

tasks, and their advancement, is facilitated through the use of a visual tool known as the "Gantt Chart" (Fig. 4). This visualization is accompanied by an explanatory table presenting task names, durations, and implementation deadlines.

Phase	Week 1	Week 2	Week 3	Week 4	Week 5	Week 6	Week 7	Week 8
Requirement Gathering								
Decide Deployment (Single / Multi node)								
Install VRA including IaaS								
Gather information about end users, approvers								
Create AD groups (System wide and Tenant Roles)								
System-Wide Roles (System, IaaS and Fabric Administrator)								
Tenant Roles (Tenant Administrator, Service Architect, Business Group Manager, Support User, Business User, Approval Administrator, Approver etc)								
Configure vRA								
Create Tenant, Business groups								
Define Reservation Policy for Business groups								
Create Network profiles								
Create Templates, Blue Prints								
Create Catalog, Catalog Items and Entitlements								
Configure custom fields in intake form								
Configure Approval Workflow								
Configure Monitoring using vRops and vRLoginsight								
Bulk Import								
End user and Cloud management training								

Fig. 4: Fragment of the "Gantt Chart" Visual Histogram for the Project on Implementing Project Leasing Operations in the Company's Activities (Microsoft Project Environment)

The group of monitoring and control processes within the project management system encompasses essential activities for tracking, analysis, and coordination of project progress and execution [8].

The effectiveness of project implementation is gauged by the extent to which set goals are achieved and business tasks are resolved, alongside adherence to established budgets and deadlines.

The outcomes of project implementation yield both internal and external benefits for the business entity. Internally, project indicators such as resource cost levels, professional growth of project participants, and more are evaluated. Externally, benefits are measured in terms of capital investments in the project and the degree to which planned objectives are realized.

An approach for evaluating project performance involves the use of a Balanced Scorecard (BSC), a framework that identifies key indicators influenced by

project outcomes. It quantitatively assesses changes in these indicators, establishing checkpoints at various project management stages to evaluate and compare actual values with planned ones. A strategic map provides a graphical representation of the Balanced Scorecard.

Note the tasks in red are along the critical path and tasks in blue are non-critical. Looking closer we see that some activities, such as Grade Site and Set Foundations, are performed in parallel. Others, such as Lay Control Cable and Remove Equipment are in a strict series relationship. We want a better understanding of task relationships, so we can coordinate activities, particularly those performed in parallel. A network diagram will help us focus in on the activity relationships. To display a network diagram of the schedule select the Task tab, View ribbon group, Gantt Chart drop down menu, and Network Diagram, Figure 5-7.

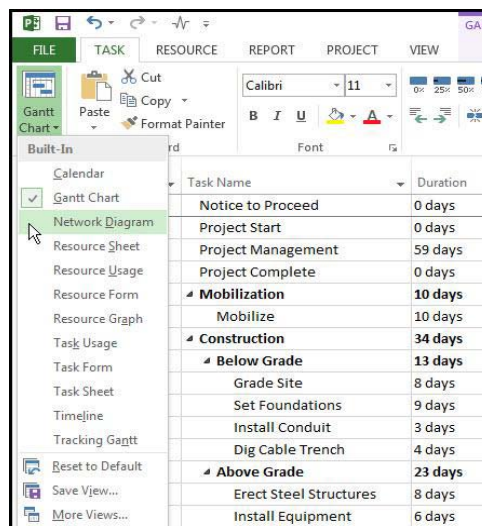

Fig. 5: A Network Diagram of the Schedule Select the Task Tab, View Ribbon Group, Gantt Chart Drop Down Menu, and Network Diagram

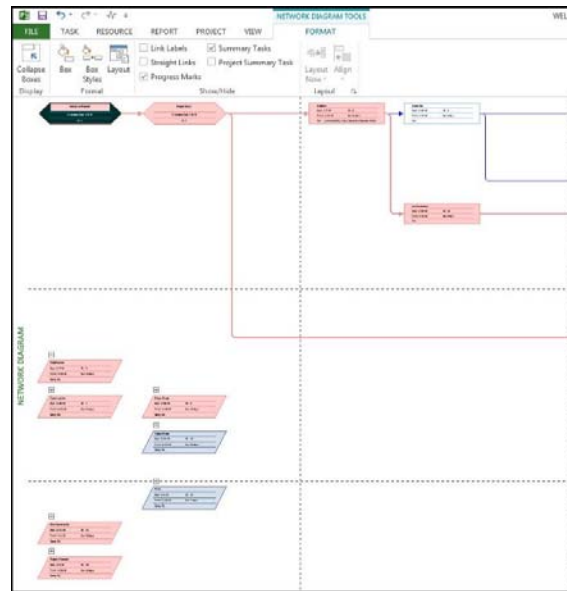

Fig. 6: The Network Diagram for Our Demonstration Project

Note the nodes that are not connected are summary tasks. Because these nodes are not providing any useful information let's remove them from our

network diagram. To do this select the Format tab, Format ribbon group, and Layout, Figure 7.

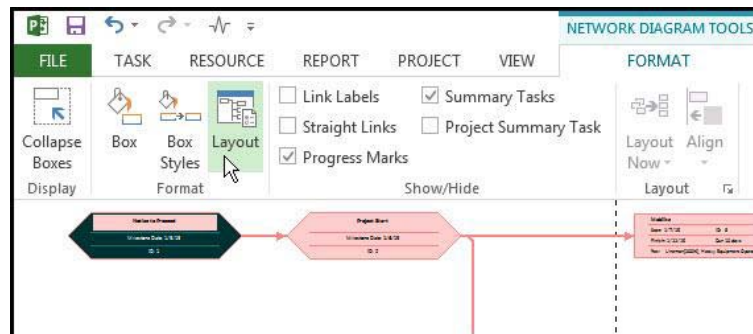

Fig. 7: Format tab

In the resulting Layout dialog toggle off, "Show summary tasks", Figure 8.

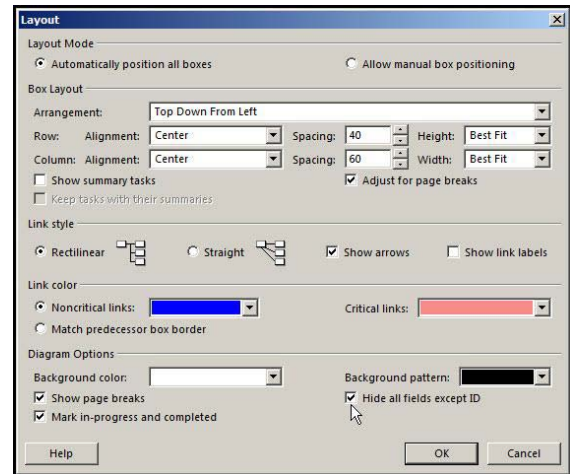
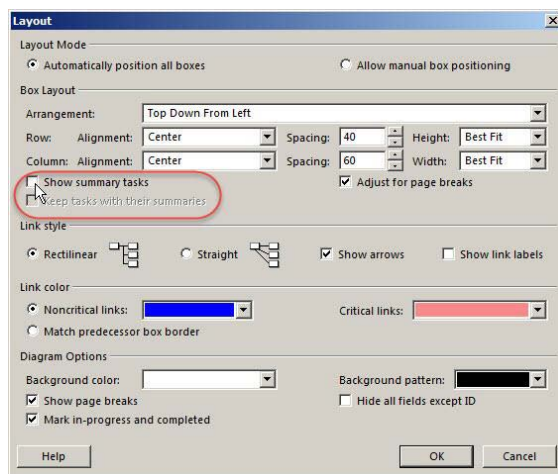

Fig. 9: Layout dialog

Task nodes are rectangular in shape. Critical tasks are in red and non-critical are blue. Each task node provides the task name, start, finish, duration, resources, and ID. This is probably more information than we need and it makes distinguishing any task node information near impossible or difficult to read when the

entire schedule network is displayed, as in Figure 8. Let's simplify the node details using the Layout dialog, Figure 9.

In the Layout dialog toggle on 'Hide all fields except ID'. Now we can clearly see the entire schedule network and associated IDs, Figure 10.

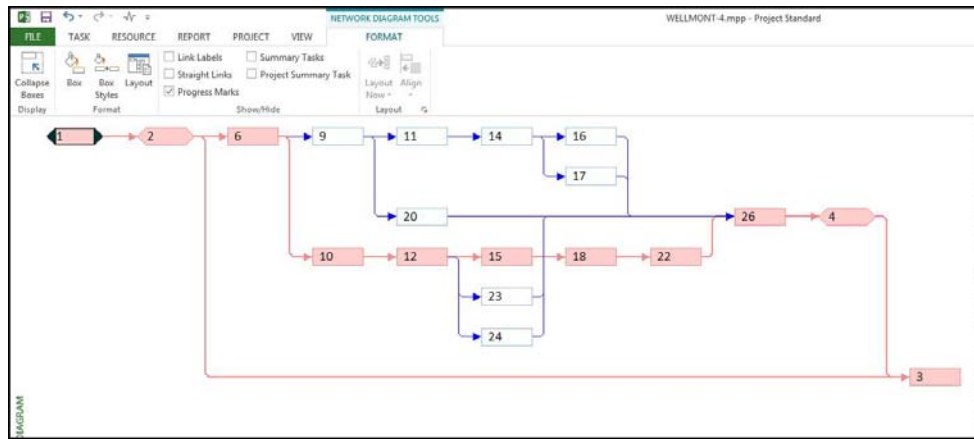

Fig. 10: Hide all fields except ID'

We also know that if we want more information on a network node we simply toggle off 'Hide all fields except ID'. With only the ID displayed as in Figure 10 we can easily see the entire network in a way that provides useful insight. The node (task) predecessor and successor is apparent for each node. The critical path is clearly visible. We can also distinguish the nodes or tasks performed in parallel and/or series. Effective project management necessitates the utilization of business intelligence (BI) to evaluate project metrics. BI is employed to ascertain and validate decisions related to meeting needs and achieving project goals. During project initiation, funding considerations demand significant attention, while upon completion, the focus shifts to evaluating implementation effectiveness.

Project indicators enable the assessment of individual management decisions and the overall project performance. Monitoring key performance indicators (KPIs) for the project is facilitated through a dashboard, an information panel displaying essential indicators through visualizations such as graphs, tables, and diagrams. The neural model comprises an external bias, which, depending on its positivity or negativity, augments or diminishes the network output upon activation of the activation function. Neuron K can be described using two equations, denoted as (1) and (2):

$$u_k = \sum_{j=1}^m w_{ki} x_j \tag{1}$$

$$y_k = \phi(u_k + b_k) \tag{2}$$

The role of the threshold is to affine the output of the linear combiner within the model:

$$u_k = u_k + b_k \tag{3}$$

Bias represents an external parameter of artificial neuron K. The same relationship can be obtained by combining formula (2) and formula (3) as follows:

$$u_k = \sum_{j=0}^m w_{ki} x_j \tag{4}$$

$$y_k = \phi(u_k) \tag{5}$$

Where the activation function is represented by.

$$\phi(v) = \begin{cases} 1, & \text{if } v \geq 0 \\ 0, & \text{if } v < 0 \end{cases} \tag{6}$$

This represents the step function. The corresponding output in this scenario is given by:

$$y_k = \begin{cases} 1, & \text{if } v \geq 0 \\ 0, & \text{if } v < 0 \end{cases} \tag{7}$$

Another activation function can be represented as.

$$\phi(v) = \begin{cases} 1, & \text{if } v \geq 1 \\ 1 + v, & \text{if } -1 < v < 1 \\ 0, & \text{if } v \leq -1 \end{cases} \tag{8}$$

Commonly used nonlinear functions are S function and radial basis function as shown in Figure 11.

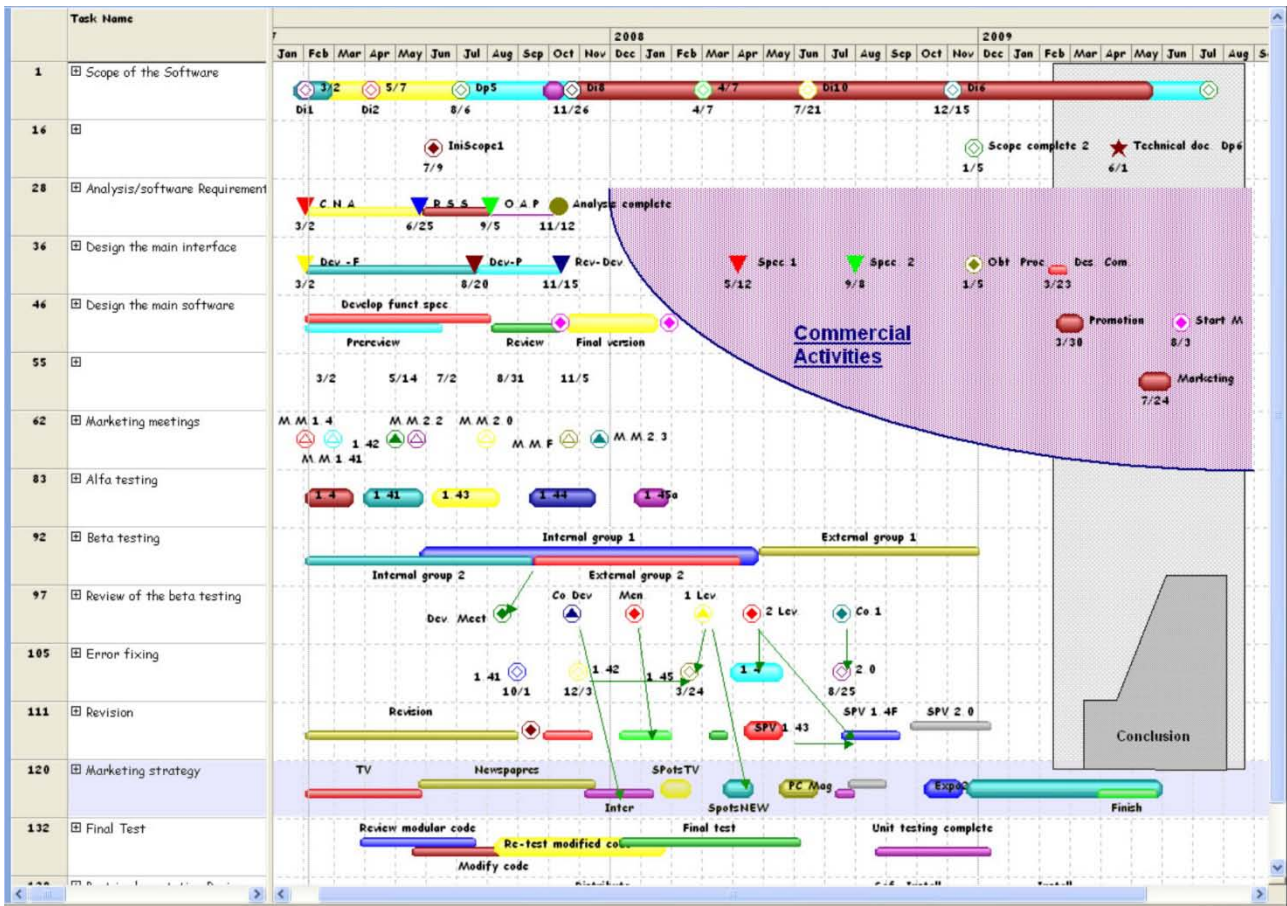

Fig. 11: Visualization of Project Data for Evaluating the Effectiveness of Project Management Decisions (Dashboard Fragment) in the PowerBI Environment

A dashboard, also referred to as an information panel, is a visually organized display of crucial information, grouped by content on a single screen for easy comprehension [5]. Fig. 5 illustrates a portion of project data visualization within a dashboard, achieved using a business analytics tool.

V. CONCLUSION

The established visual presentation designed for monitoring individual business tasks' execution within the project area can be effectively implemented within the MS Project environment. The visualization of data, in the form of a Gantt chart, enables the assessment of project stages from the perspective of allocated resources, their costs, work schedules, and task deadlines. The success of project implementation is gauged by the performance indicators of the business entity. Hence, the visualization of design data through modern VI tools, which yield operational metrics crucial for decision-making, remains pertinent. The project data analysis dashboard consists of visualizations aligned with a specific set of parameters. The assortment of infographics varies based on the significance of indicators and their relevance to decision-makers.

Analytical data are presented through tables, charts, arrow indicators, and other visualization formats, resulting from the grouping and aggregation of raw data. Dashboards facilitate the application of sorting tools and filters at different indicator levels, enabling the creation of calculated fields. In this manner, data visualization in project management within the design domain lays the groundwork for the formulation and adoption of operational management decisions. Future research endeavors will focus on visualizing project metrics derived from the balanced scorecard analysis system of project indicators.

REFERENCES RÉFÉRENCES REFERENCIAS

1. Buffardi, Kevin & Rahn, David. (2020). Fostering Entrepreneurship in Project-based Software Engineering Courses. 10.18260/1-2--34683.
2. Elijah, Paul & Elijah, Emmanuel & Ojong, Ojong. (2022). Design of Engineering Project Planning Software: A Case Study. IOSR Journal of Mechanical and Civil Engineering. 17. 38-47. 10.9790/1684-1703033847.
3. Gorbatyuk, I. (2022). Peculiarities of Project Management in the Context of Software

- Engineering. Scientific papers of Berdiansk State Pedagogical University Series Pedagogical sciences. 1. 267-274. 10.31494/2412-9208-2022-1-3-267-274.
4. Kolychev VD (2014) Programmnaia realizatsiia vizualnykh modelei upravleniia proektami [Software implementation of visual models of project management]. Modern problems of science and education, 3. Retrieved from : <http://www.science-education.ru/ru/article/view?id=13219>
 5. Kumar, Satish & Krishna, B. & Satsangi, Prem. (1994). Fuzzy systems and neural networks in software engineering project management. Appl. Intell.. 4. 31-52. 10.1007/BF00872054.
 6. Lauth, Elisa & Scholz, Steffen. (2023). Introduction and Evaluation of a Project Management Software Tool in the Context of the Administration of Science and Research Projects. 10.1007/978-981-19-9205-6_2.
 7. Nguyen Duc, Anh & Jaccheri, Letizia. (2023). Gender Equality in Software Engineering Education – A Study of Female Participation in Customer-Driven Projects. 10.1007/978-3-031-32436-9_4.
 8. Parmigiani, Nicolò & Bulgarelli, Andrea & Baroncelli, Leonardo & Addis, A. & Fioretti, Valentina & Piano, A. & Capalbi, M. & Catalano, O. & Conforti, Vito & Fiori, Michele & Gianotti, F. & Iovenitti, S. & Lucarelli, Fabrizio & Maccarone, Maria Concetta & Mineo, Teresa & Lombardi, S. & Pastore, V. & Russo, F. & Sangiorgi, P. & Project, the. (2023). The Online Observation Quality System Software Architecture for the ASTRI Mini-Array Project. 10.48550/arXiv.2302.13603.
 9. Santos, Rodrigo & Vieira, Darli & Bravo, Alencar & Suzuki, Larissa & Qudah, Fadiyah. (2021). A systematic mapping study on the employment of neural networks on software engineering projects: Where to go next?. Journal of Software: Evolution and Process. 34. 10.1002/smr.2402.
 10. Sial, Sara & Safdar, Asmara & Sajid, Muhammad & Asgher, Umer & Ayaz, Yasar. (2022). Image Classification for Project-based Learning to Differentiate Diagram and Figures..= 10.54941/ahfe1001597.
 11. Weerasuriya, Thilini & Pereira, John & Perera, Srinath & Nanayakkara, Samudaya. (2023). Software for IT Project Schedule and Cost Management. 10.1142/9789811240584_0014.
 12. Yu, Lai. (2023). Project engineering management evaluation based on GABP neural network and artificial intelligence. Soft Computing. 27. 1-13. 10.1007/s00500-023-08133-9.