

Fracture System Characterization by Pressure Probe

Sándor Szalai^{1,2*}, Péter Szűcs³, István Lempenger¹, Mohamed Zubair⁴, Mohamed Metwaly⁵, Katalin Gribovszki¹, Krisztián Baracza⁶

¹ Institute of Earth Physics and Space Science, Sopron, Csatkai E. str. 6-8., PoBox 5., Hungary

² Department of Geophysics, University of Miskolc, H-3515 Miskolc-Egyetemváros, Hungary

³ MTA-ME Geoengineering Research Group, University of Miskolc, H-3515 Miskolc-Egyetemváros, Hungary

⁴ Indian Institute of Technology Roorkee, Uttarakhand 247667, Roorkee, India

⁵ Department of Archaeology, College of Tourism and Archaeology, King Saud University, 12371 Riyadh, Saudi Arabia

⁶ Research Institute of Applied Earth Sciences, University of Miskolc, 3515 Miskolc-Egyetemváros, PoBox 2., Hungary

* Corresponding author, e-mail: szalai@ggki.hu

Received: 27 January 2022, Accepted: 21 September 2023, Published online: 26 October 2023

Abstract

Pressure Probe (PreP) is in effect a simplified penetrometer: it measures the mechanical resistivity of the soil at shallow depths dropping the probe always from the same height. The resolution of this technique is very good. It is able to detect e.g., fractures due to their decreased mechanical resistance if they are covered, but in a shallow depth with a reasonable sampling distance. An example will be demonstrated where fracture system of a slowly-moving landslide was characterized enabling also its delineation. In spite of that its maximal penetration is only about 0.5 m it may also give information from remarkable depths in case if fractures reach close to the surface indicating the borders of geological structures in larger depth. An example from India will be shown to present such results. All results have been verified by geoelectric measurements. PreP may also indicate any kind of hidden holes indirectly.

Keywords

pressure probe, penetrometer, landslide, fracture

1 Introduction

Fractures are very frequent geological features. Independently from their origin (e.g., due to faults or landslides) they may endanger constructions and eventually also human life. Fractures of any origin may reach close to the surface but hidden by soil and vegetation. Such fractures can be detected with very good resolution using the Pressure Probe (PreP) method. In this paper – after presenting the technique – two field examples of its application will be demonstrated. At first the study of the fracture system of a slowly-moving loess landslide, then that of a fault system will be presented.

2 The Pressure-Probe method

To measure the mechanical resistance of the soil we made a simplified penetrometer which is shown in Fig. 1(a); the sketch of the measurement is presented in Fig. 1(b); the measuring process in Fig. 1(c). The fractures are often hidden by vegetation and soil (Fig. 2(a)). Our tool is a metal rod on which a metal disc is fixed to increase its weight (Fig. 1(a)). One has to let it fall down from a height of

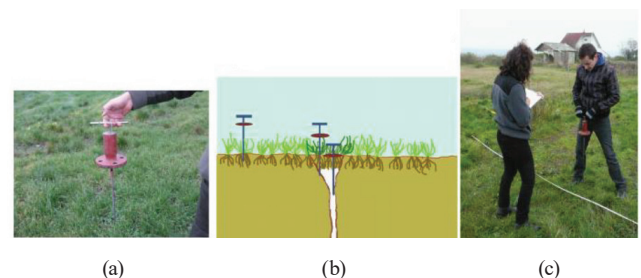

Fig. 1 The measurement process: a) The instrument; b) Sketch of the PreP method; c) Measurement and data registration

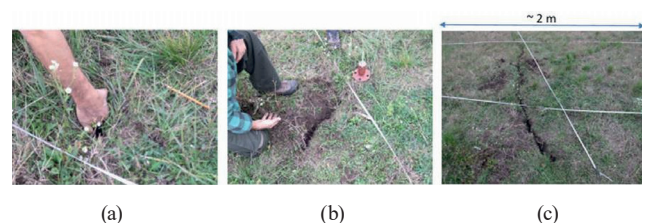

Fig. 2 The exploration of cracks: a) Exploration of the crack detected by the Pre-P method and removal of vegetation; b) A partially explored crack; c) Part of the crack which has been excavated for longer distance

1 m as perpendicular as possible (Fig. 1(c)). This height was marked on the clothes of the crew members to hold it

throughout the measuring process. The maximum depth of penetration was 30 cm in our studies which proved to be perfect in both study areas.

The PreP instrument sank deeper only in very wide fractures. In such locations 30 cm was noted enabling to present the values here without distorting the profiles/maps by extremely large values. The detailed description of the Pre-P instrument is in Appendix A. The tool generally sank between 7 and 15 cm. Larger values occurred only at fractures.

It is possible to carry out measurements on parallel profiles to map the fracture system of a study area, but interpretation of individual profiles is more straightforward. The direction of the profiles is recommended to be quasi perpendicular to the supposed direction of the most interesting fractures. If a fracture was found by the PreP, it was followed for a distance (Fig 2(b)) by removing the vegetation along the fracture by hand (Fig. 2(a)). Several fractures were found in this way and many of them were excavated for longer distances (Fig. 2(c)).

3 Field study 1: investigation of the fracture system of a slowly-moving loess landslide

3.1 Introduction to Field study 1

Landslides have serious impact to human life and constructions, it is therefore important to map landslide endangered areas, diagnose their risk and monitor them. There are many geophysical methods which may be useful in their detection. These methods are summarized e.g., by [1]. Landslides can be investigated using seismic [2], electrical or electromagnetic (e.g., [3]) and GPR (e.g., [2]) methods. Combined use of different geophysical techniques is common to improve the productivity (e.g., [4]). The aim of the geophysical techniques used to be almost exclusively the horizontal and/or vertical delineation of the sliding mass. The inner structure of the landslide was studied less often.

Geotechnical methods like Core Sampling, Cone Penetration Test Undrained (CPTU), Total Sounding (TS), Rotary Pressure Sounding (RPS), Rotary Sounding, Vane Shear Tests and Pore Pressure Measurements [5] are also very important in studying landslides. [5] combined the geotechnical and geophysical approaches.

Remote sensing techniques are also very valuable tools in landslide investigations, but if the landslide is ancient its morphologic features may have been degraded by erosion and surface observations and measurements have to be supported by reconnaissance at depth [6]. Geodetical methods are also well known in landslide investigations as shown by [7] and [8].

All of the aforementioned techniques were mostly used in the investigation of landslides where the moving material differed from the remaining material. In the Dunaszekcső area the slump arose in a homogeneous rock mass. The physical properties of the area endangered by landslides are not different from the stable area so it cannot be delineated by geophysical tools. However, the description of the fracture system enables the delineation of the endangered area.

The geotechnical tools are useful in mapping fractures, but they are expensive, and their use may be strongly limited by field conditions, like topography, mass movement danger and vegetation, which limit or prevent access by vehicles which are necessary to carry out such measurements. Geophysics has not been effective for such small-scale fracture systems disregarding from the geoelectric method (e.g., [9]). It is however always useful to verify the results of a methods with another one.

For these reasons the PreP method was used which is fast, cheap and effective. It is well applicable because most of the fractures reach close to the surface, but they are not visible due to the vegetation cover and the soil eroded into them. Crossing the roots of plants, the Pre-P instrument is able to detect fractures due to their decreased mechanical resistance.

3.2 Geological settings

The study area belongs to the Baranya Hills, Hungary. The basement formations at Dunaszekcső are Triassic–Jurassic limestones located in 200–250 m depth [10]. The uppermost 70 m of the sediment sequence are sandy and clayey loess layers with brown to red fossil soils accumulated during the Pleistocene (Fig. 3).

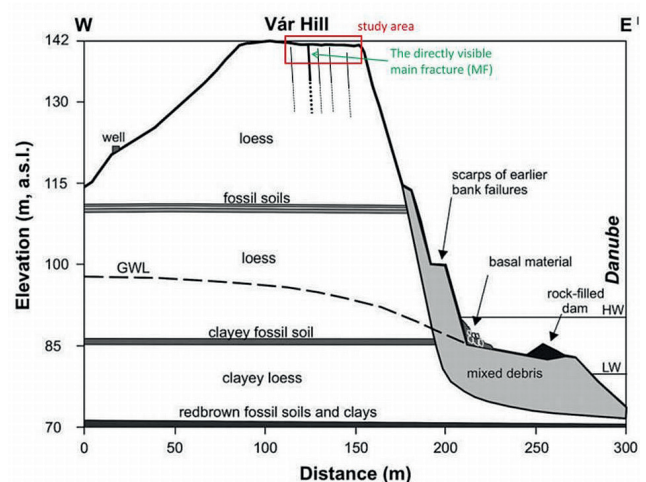

Fig. 3 Geological cross-section of the high bank at Dunaszekcső (after [10]). Vertical exaggeration: $\times 3$. GWL = ground water level (measured in a well in July 2008); HW = highest

The bluff reaches its highest point (142 m a.s.l.) at Vár Hill. The flood plain of the Danube is very narrow at Vár Hill. The bluff consists of a 20–30 m high vertical loess wall above the 10–20 m high slopes that consist of reworked loess from past landslides and fluvial mud, sand and gravel deposits of the Danube (Fig. 3).

One of the most important factors of land sliding is the hydrological condition of high bluffs. The slopes were intensively undercut by the river during each flood event [10]. The Danube has a water level fluctuation in a range of nearly 10 m. Field observations show the development of tension cracks in the loess complex parallel as well as perpendicular to the channel of the Danube.

3.3 Results and interpretation

Significant, wide fractures were interpreted where the Pre-P values were much larger than in the neighboring points. Outstanding values sometimes occurred only at one single measuring point but more often at several neighboring points (Figs. 4 and 5). Zones were assigned to all dominant fractures. These are the zones which are on their eastern side and elongate from the given dominant fracture to the next dominant one. These zones were delineated by continuous line rectangles and numbered (see Fig. 4).

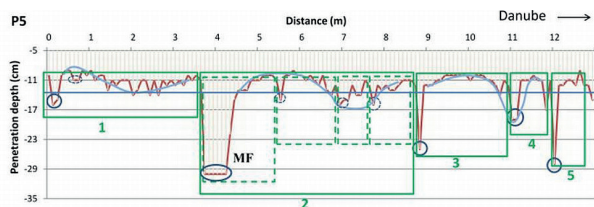

Fig. 4 A PreP profile. MF: main fracture. Ellipses denote anomalies. Continuous line rectangles present interpreted zones, dotted line rectangles subzones, respectively

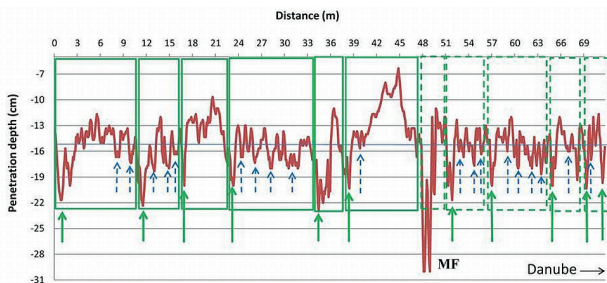

Fig. 5 PreP results along P4, which extends the area studied in detail. The solid arrows indicate the position of the larger crack and the dotted arrows those of the smaller cracks. The solid rectangles indicate the rock zones in the passive area, the dotted rectangles in the active area. The extremely small values in the range of 42–45 m are due to traffic of vehicles. MF: main fracture

These main fracture zones were further divided into smaller zones which belong to moderately significant, thinner fractures. These sub-zones were delineated by dotted line rectangles. The background values (where there are no fractures) were characteristically under 13 cm, mostly in the range of 11–13 cm. Higher values are expected to refer to the presence of fractures. The narrow range of the background values demonstrates both the homogeneity of the loess and the robustness of the Pre-P method.

Two typical profiles are here presented and interpreted. The first one was measured in the area which has already started to slump, that is eastward from the main fracture (MF, at 3.6–4.2 m) which is directly visible. It is 20–80 cm wide and the vertical displacement along it is about 10–70 cm. Five prominent anomalies are clearly recognizable on this profile (Fig. 4.). They are most likely linked to major cracks. There is only one much smaller crack west of the MF, at 0.3 m.

East of the MF approaching to the edge, the cracks occur more frequently. It is also seen that on both sides of the fractures there are mechanically consolidated, stable zones and that they are wider in the active, eastern side than in the passive, western one. The wider a crack, the wider is the consolidated zone on its eastern side. One should mention that small Pre-P values (usually below 11 cm) observed in the left end of the profile, are due to vehicles.

This example illustrates that with an appropriate sampling distance (which was 10 cm) the Pr-P method is able to detect and localize cracks, as well as to estimate their width.

Another example is shown where the profile extends deeply in the supposedly not yet endangered area (Fig. 5). It is clearly seen that the area, which is located on the stable, not-sliding, passive side (0–49 m) from the MF is also fractured. The cracks in this zone have even greater amplitude than on the active side (49–72 m). The fragmentation of the loess appears to have been also started here. It is not surprising considering the dimensions of the Castle Hill: the height of the hill above the level of the Danube River is about 50 m while it is approximately 90 m long in the direction perpendicular to the riverbed (see Fig 3). It is worth mentioning that on the passive side of the MF the blocks are wider than on the active side.

The active side of the profile is more fragmented as indicated by the higher density of thin cracks which is denoted by dashed arrows. Cracks are supposed to be where the Pre-P values exceed 15 cm. The selection of this threshold value is somewhat artificial but since the area is fairly

homogeneous, the designation of such a specific value can be justified. If the area were more inhomogeneous, one would have to take the local anomalies into consideration.

It is also important to note that it is although advisable to regard the running average representation for easier interpretation of the results this form of presentation can lead to information loss. The original, not averaged values of the major anomalies are not smaller on the active side than on the passive one, so the width of the cracks must be about the same on both sides.

Profile measurements in study site 1 proved that: 1. There are cracks also in the area not yet endangered; 2. They are at least as wide as the cracks on the active side; 3. The passive area can be divided into blocks about twice as wide as the active area; 4. There is lateral displacement already present in locations where is it expected; 5. The inner structure of the blocks is also visible inside the passive area, proving the very fine resolution of the method in spite of the former agricultural activity.

The Pre-P enables the localization of future rupture surfaces and the delineation of the endangered areas. The Pre-P method is particularly useful for examination of landslides consisting of homogeneous rocks whose investigation is fairly limited by other methods.

Electrical resistivity tomography (ERT) images have also been obtained in the study site. A number of them were presented in [9] and in [11]. Very good correlation was demonstrated between the two data sets, and they could forecast the positions of the rupture surfaces of the mass movement which occurred almost two years after the measurements. The aim of the present study is, however, to concentrate to PreP results.

4 Field study 2: investigation of a fracture network associated to a fault zone

This study site is in the state Uttarakhand, India in a sand deposit. A Syscal Junior instrument was used to acquire the ERT data with 48 electrodes and 0.2 m interelectrode spacing. Four stackings were applied. The Dipole (Dp) array was used because it is the best traditional array in detection of horizontal resistivity changes in the subsurface. Measurements were carried out by all possible symmetrical dipole arrays, resulting in the measurement of 906 data. The largest n value is equal to 6. Electrodes with relatively large, 0.01 m diameter (in comparison with the interelectrode distance) had to be used although it is not advised. It affects, however, the results less in larger depth where the results are more interesting.

The Dp data were processed using the RES2DINV [12]. Robust inversion was used with default parameters. ERT measurements detected a fault in the middle of the section (Fig. 6(a)).

The fracture system which belongs to the fault can however be very precisely characterized using the PreP (Fig. 6(a)). It shows that to the fault zone is linked to a fracture zone which is about 1 m wide (4.5-5.5 m) with the largest fractures at its both sides. A significant fracture a little bit more far away, at 6 m, may refer to a fracture in a dept which is not even seen in the ERT section. Note that here the penetration depth is in the 7-18 cm range, while elsewhere in the 4-8 cm one. In spite of outside of the fracture zone the penetration depth values are rather homogeneous at 2 m and 7.7 m the average of the measured values changes slightly. This small variation may also refer to geological variations.

PreP was therefore able verify ERT results in study site 2 and it could even give a more detailed image about the fractures in the fault zone, it could well determine its width and it is supposed to refer to another geological structures in larger depth which is not seen in the ERT section. Of course, information about deep structures are only possible to given if their effect reach to shallow surface which is achievable by the PreP tool and which led to the variation of the mechanical resistance of the soil.

5 Conclusions

A new, easy to use method, the Pre-P technique was introduced which measures a parameter proportional to the mechanical resistance of the soil. This method makes possible to map fissure systems and to delineate loose or tight zones e.g., in areas threatened by landslides.

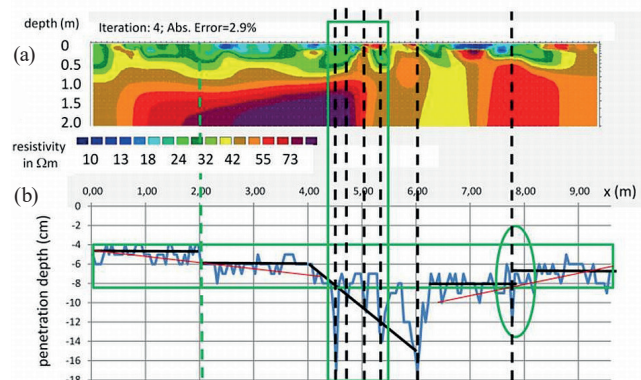

Fig. 6 Studying a fault structure: (a) ERT section. (b) PreP profile. Dotted lines denote the fractures on basis of the PreP results. Green rectangle delineates the interpreted fracture zone. Black and red lines show the average values in the given zone

The main advantages of the PreP method are: 1. its low cost; 2. its relative rapidity; 3. its very high-resolution power; 4. its easy application; 5. easy interpretation of the results; and 6. it can be used in almost any field conditions. It can be used among any topographic conditions, even in areas inaccessible by vehicles due to landslide risk or dense vegetation. In areas where the mechanical properties of the soil have been exposed to artificial changes, e.g., in agricultural areas, or in areas visited by vehicles the method may not be applied.

To be able to apply the PreP with success it is essential that the fractures reach close to the surface. This is however often the situation, the fractures are often not visible only due to vegetation or a thin layer of soil.

It was verified that even cracks 2-3 cm wide can be explored. Since increasing the sampling distance may lead to a loss detection of fractures it is recommended to make the sampling distance no greater than three times the width of the expected crack. There are no other known methods which can produce similar resolution images of a fracture system except for geotechnical ones which are, much more expensive and time consuming than the Pre-P method.

The Pre-P enabled the localization of future rupture surfaces and the delineation of the endangered areas in a landslide site. The method worked well in the study area although a part of it had been cultivated. The Pre-P method is particularly useful for studying landslides consisting of homogeneous rocks whose investigation is rather limited by other methods.

References

- [1] Jongmans, D., Garambois, S. "Geophysical Investigation of Landslides: a review", *Bulletin de la Société Géologique de France*, 178(2), pp. 101–112, 2007.
<https://doi.org/10.2113/gssgfbull.178.2.101>
- [2] Bichler, A., Bobrowsky, P., Best, M., Douma, M., Hunter, J., Calvert, T., Burns, R. "Three-dimensional mapping of a landslide using a multi-geophysical approach: the Quesnel Forks landslide", *Landslides*, 1, pp. 29–40, 2004.
<https://doi.org/10.1007/s10346-003-0008-7>
- [3] Meric, O., Garambois, S., Jongmans, D., Wathélet, M., Chatelain, J. L., Vengeon, J. M. "Application of geophysical methods for the investigation of the large gravitational mass movement of Séchillienne, France", *Canadian Geotechnical Journal*, 42(4), pp. 1105–1115, 2005.
<https://doi.org/10.1139/t05-034>
- [4] Bruno, F., Martillier, F. "Test of high-resolution seismic reflection and other geophysical techniques on the Boup landslide in the Swiss Alps", *Surveys in Geophysics*, 21, pp. 335–350, 2000.
<https://doi.org/10.1023/A:1006736824075>
- [5] Solberg, I.-L., Hansen, L., Rønning, J. S., Haugen, E. D., Dalsegg, E., Tønnesen, J. F. "Combined geophysical and geotechnical approach to ground investigations and hazard zonation of a quick clay area, mid-Norway", *Bulletin of Engineering Geology and the Environment*, 71, pp. 119–133, 2012.
<https://doi.org/10.1007/s10064-011-0363-x>
- [6] Dikau, R., Brundsen, D., Schrott, L., Ibsen, M.-L. (eds.) "Landslide recognition: identification, movement and causes", Wiley, 1996. ISBN 978-0-471-96477-3
- [7] Újvári, G., Mentés, G., Bányai, L., Kraft, J., Gyimóthy, A., Kovács, J. "Evolution of a bank failure along the River Danube at Dunaszekcső Hungary", *Geomorphology*, 109, pp. 197–209, 2009.
<https://doi.org/10.1016/j.geomorph.2009.03.002>
- [8] Bányai, L., Mentés, G., Újvári, G. "A dunaszekcsői magaspartsuszamlás geodéziai megfigyelése" (Geodetic Observation of High Bank Failures at Dunaszekcső), *Geodézia és Kartográfia*, (65)11-12, pp. 7–11, 2013. (in Hungarian)
<https://doi.org/10.1016/j.geomorph.2013.11.032>

The results in study site 2 have shown that beside of PreP can verify ERT results it was able to give a more detailed image about the fractures in the fault zone. It could moreover well determine its width and it is supposed to refer to other geological structures in larger depth which is not seen in the ERT section.

It was demonstrated that the PreP method may be very useful in description of fractures thus in delineation of potential landslide hazardous areas and for mapping their fracture system, or characterize fracture zones e.g., due to a fault in areas which are not heavily influenced by human activity.

Although the very simple method recommended by the authors can only be used in special cases (i. e., the presented one that is in studying landslides in homogeneous loess soil) in such situations it cannot always be replaced by other geophysical methods.

Acknowledgement

The authors would like to thank the Research Supporting Project Number (RSP2023R89), King Saud University, Riyadh, Saudi Arabia for funding this work. The research was carried out in the framework of the GINOP-2.3.2-15-2016-00010 "Development of enhanced engineering methods with the aim at utilization of subterranean energy resources" project of the Research Institute of Applied Earth Sciences of the University of Miskolc in the framework of the Széchenyi 2020 Plan, funded by the European Union, co-financed by the European Structural and Investment Funds.

- [9] Szalai, S., Szokoli, K., Metwaly, M., Gribovszki, Z. Prácer, E. "Prediction of the location of future rupture surfaces of a slowly moving loess landslide by Electrical Resistivity Tomography", *Geophysical Prospecting*, 65(2), pp. 596–616, 2017. <https://doi.org/10.1111/1365-2478.12421>
- [10] Moyzes, A., Scheuer, G. "A dunaszekcsői magaspart mérnök-geológiai vizsgálata (Engineering geological investigation of the high bank at Dunaszekcső)", *Földtani Közlöny - Bulletin of the Hungarian Geological Society* 108, pp. 213–226, 1978. (in Hungarian)
- [11] Szokoli, K., Szarka, L., Metwaly, M., Kalmár, J., Prácer, E., Szalai, S. "Characterisation of a landslide by its fracture system using Electric Resistivity Tomography and Pressure Probe methods", *Acta Geodaetica et Geophysica*, 53, pp. 15-30, 2018. <https://doi.org/10.1007/s40328-017-0199-3>
- [12] Loke, M. H. "Rapid 2-D Resistivity & IP Inversion using the least-squares method", RES2DINV*64 ver.4.08. Geotomo Software, 2018. [software] Available at: <https://www.geotomosoft.com/downloads.php>

Appendix A

The measuring device

The principle of the Pre-P method using a manual pressure probe is the next: dropping the probe always from the same height, its penetration depth is the function of the mechanical resistance of the soil. The probe (Fig. 1(a)) consists of the T-shaped metal rod and the discs superimposed on it to increase its weight. The probe weighs about 2,8 kg, and the rod itself is 390 g. Its total length is 50 cm, its maximum penetration depth 30 cm (Fig. 7). On the rod there is a depth scale.

While the diameter of the metal rod is 10 mm, that of the tip end is 1.8 mm. The diameter of the 20 mm thick lower weight is 140 mm preventing the probe from dropping into wider cracks. The smaller weight above is about 60 mm in diameter. Its thickness is 120 mm. This design facilitates to drop the Probe vertically reducing this type of error. 1 m drop height is perfect for both the measurement effectivity and convenience for most people. Only in more compact soils may be necessary to drop the probe from a larger height to get reasonable results. In such cases, increasing the weight of the probe might be simpler.

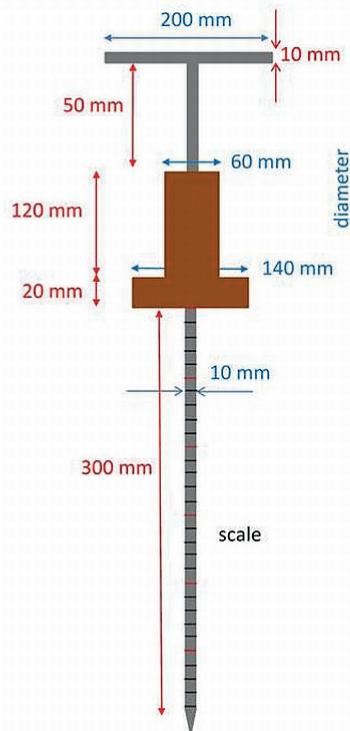

Fig. 7 The Pre-P instrument. Parts: 1. T-shaped metal rod (grey); 2. discs (brown). Total length of the probe is 50 cm