

5-31-1992

Disinfection of wastewater using ultraviolet radiation

David L. Klemm
New Jersey Institute of Technology

Follow this and additional works at: <https://digitalcommons.njit.edu/theses>



Part of the [Environmental Engineering Commons](#)

Recommended Citation

Klemm, David L., "Disinfection of wastewater using ultraviolet radiation" (1992). *Theses*. 2292.
<https://digitalcommons.njit.edu/theses/2292>

This Thesis is brought to you for free and open access by the Electronic Theses and Dissertations at Digital Commons @ NJIT. It has been accepted for inclusion in Theses by an authorized administrator of Digital Commons @ NJIT. For more information, please contact digitalcommons@njit.edu.

Copyright Warning & Restrictions

The copyright law of the United States (Title 17, United States Code) governs the making of photocopies or other reproductions of copyrighted material.

Under certain conditions specified in the law, libraries and archives are authorized to furnish a photocopy or other reproduction. One of these specified conditions is that the photocopy or reproduction is not to be “used for any purpose other than private study, scholarship, or research.” If a user makes a request for, or later uses, a photocopy or reproduction for purposes in excess of “fair use” that user may be liable for copyright infringement,

This institution reserves the right to refuse to accept a copying order if, in its judgment, fulfillment of the order would involve violation of copyright law.

Please Note: The author retains the copyright while the New Jersey Institute of Technology reserves the right to distribute this thesis or dissertation

Printing note: If you do not wish to print this page, then select “Pages from: first page # to: last page #” on the print dialog screen

The Van Houten library has removed some of the personal information and all signatures from the approval page and biographical sketches of theses and dissertations in order to protect the identity of NJIT graduates and faculty.

ABSTRACT

Disinfection of Wastewater Using Ultraviolet Radiation

by
David L. Klemm

The disadvantages associated with the use of chlorine for disinfection, in conjunction with improvements in ultraviolet radiation disinfection technologies have led to the recent increased use of ultraviolet radiation to provide disinfection of effluents from wastewater treatment plants. The theory of ultraviolet radiation and the engineering design of the ultraviolet disinfection system are discussed in depth.

The operational history and records of two wastewater treatment plants that use ultraviolet radiation for disinfection were analyzed in an attempt to develop correlations on the factors that affect ultraviolet radiation disinfection efficiency and to investigate as to whether disinfection with ultraviolet radiation is a legitimate alternative to disinfection with chlorine. One facility is a tertiary wastewater treatment plant while the other is a secondary facility.

A high level of disinfection was consistently observed at the tertiary case study facility under the range of operating conditions encountered since the ultraviolet radiation system was put on-line in January 1991. The ultraviolet disinfection system at the secondary case study facility in general provided a satisfactory level of disinfection; however, it was subject to poor disinfection efficiencies upon high plant flows.

Based on the performance of the two case study facilities, ultraviolet radiation disinfection systems can be successfully used to disinfect treated wastewater effluents from both secondary and tertiary facilities. Ultraviolet radiation does represent a reliable, safe and practical alternative to disinfection with chlorine.

DISINFECTION OF WASTEWATER
USING
ULTRAVIOLET RADIATION

by
David L. Klemm

A Thesis
Submitted to the Faculty of the
New Jersey Institute of Technology
in Partial Fulfillment of the Requirements for the Degree of
Masters of Science in Environmental Engineering
May 1992

APPROVAL PAGE

Disinfection of Wastewater
Using
Ultraviolet Radiation

by
David L. Klemm
(S.S. # 155-66-7987)

Dr. Hsin-Neng Hsieh, Thesis Advisor
Associate Professor of Civil and Environmental Engineering, NJIT

Dr. Dorairaja Raghu, Committee Member
Professor of Civil and Environmental Engineering, NJIT

BIOGRAPHICAL SKETCH

Author: David L. Klemm

Degree: Master of Science in Environmental Engineering

Date: December, 1992

Undergraduate and Graduate Education:

- Master of Science in Environmental Engineering, New Jersey Institute of Technology, Newark, NJ, 1992
- Bachelor of Science in Civil Engineering, Worcester Polytechnic Institute, Worcester, MA, 1990

Major: Civil and Environmental Engineering

Professional Position:

- Engineer, Wastewater Department, Killam Associates, Millburn, NJ, 1990 to present

ACKNOWLEDGEMENTS

The author would like to express his sincerest gratitude to his advisor, Dr. Hsin-Neng Hsieh, for his guidance and encouragement throughout this project.

Special thanks to Dr. Dorairaja Raghu for serving as a member on the committee.

The author would like to thank Tim Newton, laboratory operator at the Verona WWTP, for sharing his operating experience and knowledge of the UV system and for providing me with lab data.

In addition, the author would also like to express his gratitude to Dan Ranich, plant superintendent for the New Providence WWTP, for his assistance in making the daily operator's logs available and for his help throughout this project.

I would also like to thank Mark Tompeck, John Tobia, Mark Anderson and the entire Killam lab for their assistance.

A special thanks to Cliff Wilkinson, the author's former boss at Killam Associates, for being a friend, for helping develop the idea for the project from the beginning and for giving me guidance throughout the project.

Finally, I would like to thank my sister, Linda, for the use of her computer and printer.

TABLE OF CONTENTS

| | <u>PAGE</u> |
|---|-------------|
| 1.0 INTRODUCTION | 1 |
| 1.1 Purpose of Disinfection | 2 |
| 2.0 DESIGN OF THE UV SYSTEM | 5 |
| 2.1 Mechanism of Disinfection | 5 |
| 2.1.1 Photoreactivation and Dark Repair | 6 |
| 2.2 Disinfection Model | 9 |
| 2.3 Lamps | 9 |
| 2.4 Absorbance | 12 |
| 2.5 Intensity and Dosing | 12 |
| 2.6 Hydraulics of UV Reactors | 13 |
| 2.6.1 Aspect Ratio | 15 |
| 2.6.2 Transverse Dispersion | 16 |
| 2.6.3 Axial Dispersion | 16 |
| 2.6.4 Residence Time Distribution (RTD) Curve | 17 |
| 2.7 Factors that Affect Transmission of UV Light to Microorganisms | 20 |
| 2.8 Properties of Wastewater to be Disinfected | 21 |
| 2.9 Operation and Maintenance | 22 |
| 2.9.1 Process Control | 24 |
| 2.9.2 Maintenance | 26 |
| 2.10 Ventilation | 27 |
| 2.11 Cost Analysis | 28 |
| 3.0 NEW PROVIDENCE SECONDARY WASTEWATER TREATMENT PLANT - CASE STUDY | 29 |
| 3.1 Facility Description and Brief History | 29 |
| 3.1.1 New NJPDES Permit Requirements | 31 |

| | | |
|---------|---|----|
| 3.1.2 | Disinfection Alternatives | 32 |
| 3.1.2.1 | Chlorination/Dechlorination | 32 |
| 3.1.2.2 | Ultraviolet Light (UV) | 33 |
| 3.2 | Design Criteria | 34 |
| 3.2.1 | Design Flow | 34 |
| 3.2.2 | Design Parameters | 35 |
| 3.3 | Description of UV System | 35 |
| 3.3.1 | System Control | 39 |
| 3.3.2 | Elapsed Time Meter | 40 |
| 3.3.3 | UV Intensity Monitor | 41 |
| 3.4 | Analysis of UV System Performance | 41 |
| 3.4.1 | Flow | 42 |
| 3.4.1.1 | Flow Design Values | 43 |
| 3.4.1.2 | Fecal Coliform and Flow Correlations | 43 |
| 3.4.1.3 | Enterococci and Flow Correlations | 45 |
| 3.4.2 | Suspended Solids | 46 |
| 3.4.3 | Transmittance | 49 |
| 3.4.4 | Temperature | 50 |
| 3.4.5 | pH | 51 |
| 3.4.6 | BOD, CBOD, & NBOD | 52 |
| 3.4.7 | Dissolved Oxygen | 53 |
| 4.0 | VERONA TERTIARY WASTEWATER TREATMENT PLANT - CASE STUDY | 54 |
| 4.1 | Facility Description and Brief History | 54 |
| 4.2 | Design Criteria | 57 |
| 4.3 | Description of UV System | 60 |
| 4.3.1 | System Control | 64 |

| | | |
|-------|--|----|
| 4.3.2 | UV Intensity Meter | 65 |
| 4.3.3 | Cleaning UV Lamps | 66 |
| 4.4 | Analysis of UV System Performance | 66 |
| 4.4.1 | Flow | 68 |
| 4.4.2 | Suspended Solids | 70 |
| 4.4.3 | Temperature | 71 |
| 4.4.4 | pH | 71 |
| 4.4.5 | BOD, CBOD, & NBOD | 72 |
| 4.4.6 | Dissolved Oxygen | 72 |
| 4.4.7 | Alkalinity | 72 |
| 5.0 | COMPARISON BETWEEN SECONDARY WWTP AND TERTIARY WWTP UV PERFORMANCE | 74 |
| 5.1 | Summary of UV Performance - New Providence Secondary WWTP | 74 |
| 5.2 | Summary of UV Performance - Verona Tertiary WWTP | 75 |
| 5.3 | Physical Description of UV Systems at both WWTP's | 75 |
| 5.4 | Suspended Solids | 76 |
| 5.5 | Transmittance | 77 |
| 5.6 | Flow | 77 |
| 5.7 | Degree of Disinfection using Chlorine as Compared to UV Radiation | 79 |
| 5.7.1 | New Providence WWTP | 79 |
| 5.7.2 | Verona WWTP | 81 |
| 6.0 | CONCLUSIONS | 84 |
| 6.1 | Summary of Findings from Case Study Facilities | 84 |
| 6.2 | Hyrum, Utah Municipal Wastewater Treatment Plant | 86 |
| 6.3 | Future of UV Disinfection of Wastewater | 86 |

| | | |
|-----|--|-----|
| 7.0 | APPENDICES | 90 |
| | Appendix A - New Providence WWTP - NJPDES Permit | 90 |
| | Appendix B - New Providence WWTP - Daily Operator's Log Data | 104 |
| | Appendix C - New Providence WWTP - Graphs | 121 |
| | Appendix D - Verona WWTP - NJPDES Permit | 139 |
| | Appendix E - Verona WWTP - Daily Operator's Log Data | 149 |
| | Appendix F - Verona WWTP - Graphs | 156 |
| 8.0 | ENDNOTES | 169 |
| 9.0 | BIBLIOGRAPHY | 175 |

LIST OF TABLES

| | <u>PAGE</u> |
|--|-------------|
| Table 2-1. Relative Resistance of Different Microorganism to UV Light | 14 |
| Table 3-1. UV System Design Parameters (New Providence WWTP) | 36 |
| Table 4-1. UV System Design Parameters (Verona WWTP) | 58 |
| Table 5-1. New Providence WWTP Effluent Fecal Coliform Concentrations Using Chlorine as the Disinfecting Agent | 80 |
| Table 5-2. Verona WWTP Effluent Fecal Coliform Concentrations Using Chlorine as the Disinfecting Agent | 82 |
| Table 3-2. New Providence WWTP Daily Operator's Log Data | 104 |
| Table 4-2. Verona WWTP Daily Operator's Log Data | 149 |

LIST OF FIGURES

| | <u>PAGE</u> |
|--|-------------|
| Figure 2-1. Borough of New Providence, Union County, New Jersey. Schematic of Open-Channel, Modular UV System. | 11 |
| Figure 2-2. Example of UV System Utilizing Teflon Tubes. | 23 |
| Figure 3-1a. Borough of New Providence, Union County, New Jersey. WWTP Site Plan. | 30 |
| Figure 3-1b. Ultraviolet Facilities at the New Providence WWTP. | 38 |
| Figure 4-1a. Township of Verona, Essex County, New Jersey. Wastewater Treatment Plant Location Plan. | 55 |
| Figure 4-1b. Township of Verona, Essex County, New Jersey. Wastewater Treatment Plant Additions, Flow Diagram. | 56 |
| Figure 4-1c. Ultraviolet Disinfection Facilities at the Verona WWTP. | 61 |
| Figure 4-1d. Sectional View of Ultraviolet Disinfection Facilities at the Verona WWTP. | 62 |
| Figure 4-1e. Sectional View of Ultraviolet Disinfection Facilities at the Verona WWTP | 63 |
| Figure 3-1. New Providence WWTP - Effluent Fecal Coliform Vs. Instantaneous Flow | 122 |
| Figure 3-2. New Providence WWTP - Effluent Fecal Coliform Vs. Instantaneous Flow Per UV Bank | 123 |
| Figure 3-3. New Providence WWTP - Effluent Fecal Coliform Vs. Effluent Plant Flow | 124 |
| Figure 3-4. New Providence WWTP - Effluent Fecal Coliform Vs. Effluent Flow Per UV Bank | 125 |
| Figure 3-5. New Providence WWTP - Effluent Fecal Coliform Vs. Effluent Suspended Solids | 126 |
| Figure 3-6. New Providence WWTP - Effluent Fecal Coliform Vs. Effluent Temperature (A.M.) | 127 |
| Figure 3-7. New Providence WWTP - Effluent Fecal Coliform Vs. Effluent pH (A.M.) | 128 |
| Figure 3-8. New Providence WWTP - Effluent Fecal Coliform Vs. Effluent BOD | 129 |
| Figure 3-9. New Providence WWTP - Effluent Fecal Coliform Vs. Effluent CBOD | 130 |

| | | |
|--------------|--|-----|
| Figure 3-10. | New Providence WWTP - Effluent Fecal Coliform Vs. Effluent NBOD | 131 |
| Figure 3-11. | New Providence WWTP - Effluent Fecal Coliform Vs. Effluent Dissolved Oxygen | 132 |
| Figure 3-12. | New Providence WWTP - Effluent Enterococci Vs. Instantaneous Flow Per UV Bank | 133 |
| Figure 3-13. | New Providence WWTP - Effluent Enterococci Vs. Effluent Flow Per UV Bank | 134 |
| Figure 3-14. | New Providence WWTP - Effluent Enterococci Vs. Effluent Suspended Solids | 135 |
| Figure 3-15. | New Providence WWTP - Effluent Enterococci Vs. Effluent BOD | 136 |
| Figure 3-16. | New Providence WWTP - Effluent Fecal Coliform Vs. Effluent Plant Flow (all values included) | 137 |
| Figure 3-17. | New Providence WWTP - Effluent Fecal Coliform Vs. Instantaneous Flow Per UV Bank (all values included) | 138 |
| Figure 4-1. | Verona WWTP - Effluent Fecal Coliform Vs. Flow | 157 |
| Figure 4-2. | Verona WWTP - Effluent Fecal Coliform Vs. Effluent Suspended Solids | 158 |
| Figure 4-3. | Verona WWTP - Effluent Fecal Coliform Vs. Effluent Temperature | 159 |
| Figure 4-4. | Verona WWTP - Effluent Fecal Coliform Vs. Effluent pH | 160 |
| Figure 4-5. | Verona WWTP - Effluent Fecal Coliform Vs. Effluent BOD | 161 |
| Figure 4-6. | Verona WWTP - Effluent Fecal Coliform Vs. Effluent CBOD | 162 |
| Figure 4-7. | Verona WWTP - Effluent Fecal Coliform Vs. Effluent NBOD | 163 |
| Figure 4-8. | Verona WWTP - Effluent Fecal Coliform Vs. Effluent Dissolved Oxygen | 164 |
| Figure 4-9. | Verona WWTP - Effluent Fecal Coliform Vs. Effluent Alkalinity | 165 |
| Figure 4-10. | Verona WWTP - Effluent Enterococci Vs. Flow | 166 |
| Figure 4-11. | Verona WWTP - Effluent Enterococci Vs. Effluent Suspended Solids | 167 |
| Figure 4-12. | Verona WWTP - Effluent Enterococci Vs. Eff. Temperature | 168 |

LIST OF SYMBOLS

| | |
|---------------|--|
| N | = Density of organisms after exposure to UV (organisms/100 ml) |
| N_0 | = Initial Density of organisms (organisms/100 ml) |
| I | = Intensity of UV irradiation ($\mu\text{W}/\text{cm}^2$) |
| t | = Time of exposure (seconds) |
| k | = Inactivation rate constant (sec^{-1}) |
| Dose | = UV Dose, $\mu\text{W}\cdot\text{sec}/\text{cm}^2$ |
| I_0 | = lamp surface intensity ($\mu\text{W}/\text{cm}^2$) |
| a | = medium absorbance (cm^{-1}) |
| d | = distance from UV lamp to point of Intensity measurement (cm) |
| R_e | = Reynold's Number |
| C | = Degrees Celcius |
| F | = Degrees Fahrenheit |
| BOD | = Biochemical Oxygen Demand (mg/l) |
| COD | = Chemical Oxygen Demand (mg/l) |
| CBOD | = Carbonaceous Biochemical Oxygen Demand (mg/l) |
| NBOD | = Nitrogenous Biochemical Oxygen Demand (mg/l) |
| SS | = Suspended Solids (mg/l) |
| Q | = Flow (MGD, gpm, etc.) |
| pH | = pH measured in Standard Units (S.U.) |
| NH_3 | = Ammonia Nitrogen (mg/l) |
| D.O. | = Dissolved Oxygen (mg/l) |
| L | = UV Reactor Length (length) |
| R_h | = Hydraulic Radius (length) |
| E | = Dispersion ($\text{length}^2/\text{sec}$) |
| E_x | = Axial Dispersion ($\text{length}^2/\text{sec}$) |

- t_p/T = Average Velocity Short Circuiting Index
 t_{50}/T = Average Mass Short Circuiting Index
 t_{90}/t_{10} = Morrill Index
 T = theoretical mean detention time (V_v/Q)
 t_{90} = time at which ninety (90) percent of tracer has passed through the reactor
 t_{10} = time at which ten (10) percent of tracer has passed through the reactor
 t_p = time at which the peak concentration of the tracer appears
 t_{50} = time at which fifty (50) percent of tracer has passed through the reactor
 V_v = liquid volume in the UV reactor or UV bank
 t_f = time at which the tracer first appears
 t_p = time at which the peak concentration of the tracer appears
 O = the meantime (centroid) of the curve

DISINFECTION OF WASTEWATER USING ULTRAVIOLET RADIATION

1.0 INTRODUCTION

In recent years the use of ultraviolet (UV) radiation as a means for disinfecting wastewater has increased dramatically. Disinfection with UV now represents a viable alternative to chlorine which had in the past been the method of disinfection used almost exclusively by wastewater treatment plants. UV disinfection has become more attractive for several reasons. Much research in recent years has led to the development of more reliable equipment and increased disinfection efficiencies. Some of the advantages of UV disinfection that has led to its increased popularity include:

- non-chemical disinfectant
- does not form potentially toxic by-products such as trihalomethanes (THMS)
- very effective in killing both pathogenic and viruses with relatively smaller germicidal dose latitudes
- not pH dependent
- does not leave potentially harmful residuals that could affect aquatic life
- safety advantages - eliminates the possibility of injury of persons due to accidental exposure to chlorine gas
- lower life cycle costs
- ease of operation and maintenance of UV equipment¹

One of the big disadvantages with the continued use of chlorine as the means of disinfecting wastewater is the formation of carcinogenic compounds such as trihalomethanes (THMS). The residual chlorine remaining in the effluent discharged to the natural waterway often reacts with the organic matter in the receiving waters to form organochlorine compounds. These chlorinated

byproducts have been found to be carcinogenic and teratogenic, especially to freshwater fish. Based on testing, chlorine residuals above 1 mg/l have been found to kill fish. The magnitude of this problem is magnified greatly when either a large effluent quantity is being discharged or a small body of water is to receive the effluent where the effects of dilution are greatly reduced. Many wastewater discharge permits now include residual chlorine limits for the effluent discharged to natural waters.²

Disinfection using UV radiation is also much safer for the wastewater treatment plant operator, since there are no chemicals that could spill or gases that may be released as is the case when disinfection is accomplished through the use of chemical disinfecting agents.

1.1 Purpose of Disinfection

For many years people have been aware of the importance of disinfecting water in order to reduce and eliminate the spread of waterborne diseases. In order to achieve this goal, standards have been developed and enforced to limit the level of certain indicator organisms discharged to receiving bodies of water. The most common indicator organism used today is fecal coliform, although other indicator organisms such as enterococcus and *E. coli* have gained more support as being more representative of fecal pollution in recent years.³

The purpose of wastewater disinfection is to limit the number of pathogens discharged into the aquatic environment, thus reducing the incidence of waterborne diseases that are transmitted through physical contact, ingestion of water, or consumption of diseased marine life. Pathogenic organisms, because

of their enteric origin, do not thrive when released to natural bodies of water. When pathogens are released to natural waterways, the body of water naturally undergoes a purifying process that eliminates pathogenic organisms. However, the main purpose of wastewater disinfection is to reduce the density of pathogenic organism and to expedite this natural purifying process. The intent of wastewater disinfection was never to sterilize the water before discharge. Disinfection is an vital part to the entire wastewater treatment process, but can not be used as a substitute for the prior treatment processes. Effective disinfection is highly dependent on efficient treatment throughout the plant prior to disinfection.⁴

Many studies, including some by the U.S. EPA, have concluded that the rate of incidence of waterborne diseases increases when people are exposed to wastewater effluents that have not been disinfected prior to discharge. It has been argued by some people that chlorination (method of disinfection most commonly used) of wastewater prior to discharge to natural waterways is detrimental to public health and to the aquatic ecology. The arguments against disinfection of wastewater with chlorine is that chlorination may produce chloramines, organo-chloramines, and chlorinated organic compounds that have increased toxicity and are less biodegradable. These compounds or free chlorine itself may result in any or all of the following conditions: disruption of the self-purification process of the receiving water; chronic or acute toxic effects on aquatic plants and animals; behavioral changes in aquatic organisms including interruption of natural migration or spawning cycles; and reduction in overall quality of water if to be used for potable water source. However, there is no firm evidence to support this position. Therefore, it may be concluded that the benefits received by the public by

reducing pathogens discharged to waterways, far outweigh any detrimental aquatic effects caused by chlorination.⁵

However, the use of UV irradiation as the method of wastewater disinfection eliminates the possibility of the adverse effects associated with chlorination as discussed above, while still reducing the amount of pathogens released to the receiving waterway. The public and aquatic environment have much to gain when wastewater is disinfected with a UV disinfection system that is designed and operated correctly. However, a better knowledge of the design criteria and a longer case history of successfully operated facilities is needed for UV wastewater disinfection systems to reach its full potential. This thesis will analyze the current status and viability of UV systems for disinfection of wastewater effluents and also the possible future of UV in this area. Data from the UV treatment process of two wastewater treatment plants will be analyzed.

2.0 DESIGN OF THE UV SYSTEM

There are many factors that must be considered in order to design a UV disinfection system that produces a high quality effluent as well as being cost effective. Three basic areas should be considered when designing a UV disinfection system:

- 1) Reactor hydraulics
- 2) Properties of wastewater to be disinfected
- 3) Factors that affect transmission of UV light to microorganisms. ⁶

The theory of UV disinfection and considerations in designing of the system will be discussed in the following sections.

2.1 Mechanism of Disinfection

Ultraviolet irradiation rays are broken into three subdivisions depending on the wavelength: 1) longwave UV-A (wavelength = 315 to 400 nm); 2) medium wave UV-B (wavelength = 280 to 315 nm); and 3) germicidal shortwave UV-C (wavelength < 280 nm). Germicidal UV is the type used for disinfection purposes. The reason for this, is that the peak UV absorption efficiency for DNA lies between 250 and 260 nm. The mechanism for UV disinfection is that as sufficient exposure of UV light penetrates the cell wall of the microorganism it will inactivate the cells by photochemical breakdown of the DNA. The UV irradiation absorbed by the microorganism will damage or modify the genetic information within the DNA of the cell. The damaged cell will no longer be able to replicate its genetic information and will result in death of that cell. ⁷

Low-pressure mercury vapor lamps that emit light in which the vast majority of light has a wavelength of 254 nm is commonly used for the purposes of disinfection of water and wastewater.

2.1.1 Photoreactivation and Dark Repair

A phenomenon unique to UV disinfection is the ability of cells to repair themselves after being damaged by UV radiation. This may occur through two different mechanisms: 1) photoreactivation and 2) dark repair. Photoreactivation is the ability of damaged microorganisms to recover when exposed to certain wavelengths including those found in sunlight. This recovery process can occur very quickly (in a few minutes) when exposed to the reactivating light rays. Research has also revealed that a second mechanism of cell repair exists that does not require the presence of light, this is called dark repair.⁸

The exact mechanism and details of the mechanism for photoreactivation are not thoroughly understood by researchers at this time. However, through studies it is known that the reactivating wavelength varies from microorganism to microorganism and that some microorganisms repair more readily than others, while some are unable to repair themselves once damaged by UV radiation. The range of wavelengths to cause photoreactivation is generally between 310 nm and 490 nm. Research has shown that the following organisms do not have the repair mechanism:

- *Haemophilus influenzae*
- *Diplococcus pneumoniae*
- *Bacillus subtilis*
- *Micrococcus radiodurans*

In addition, most viruses do not have the repair ability unless they are in a host cell that has the ability to repair itself.⁹

The following microorganisms are known to have the ability to photoreactivate:

- Streptomyces
- Escherichia coli
- Saccharomyces
- Aerobacter
- Micrococcus
- Erwinia
- Proteus
- Penicillium
- Neurospora¹⁰

The degree and extent of cell repair is also a function of several other environmental conditions that the cells are exposed to in addition to the presence of light with the proper reactivating wavelength. Environmental conditions that inhibit active cell metabolism and cell division immediately following exposure to UV light will tend to decrease the disinfecting efficiency of UV radiation. For instance, low temperature and low nutrient levels will slow the process of cell division and cell metabolism increasing the degree of cell repair. The reason for this is that these inhibitory effects allow time for the cell to repair its DNA before it erroneously and lethally replicates itself. In addition, a cell population in its lag or stationary growth stage will also have a greater chance for cell repair since by definition the rate of cell division is much slower than a population that is during its period of exponential growth. Conversely, the degree of cell repair will be much less (hence UV disinfection efficiency increased) if conditions exist that encourage rapid cell metabolism and cell division.¹¹

The UV system design engineer must be aware of the phenomenon of photoreactivation and take this into account in his design. The degree of photoreactivation will vary depending on the prevailing conditions at each wastewater treatment facility. In general, conditions exist that are conducive to photoreactivation - nutrient levels are generally low in treated effluent and the population of the majority of microorganisms will be in the stationary stage. The characteristics of the receiving waters will also impact the degree of photoreactivation. If discharge is into a clear shallow stream with a low amount of turbidity, these conditions would be conducive to a higher degree of cell repair than if discharge were to a deep river with a large amount of turbidity. In addition, the amount of sunlight and average temperatures expected for a particular area will impact the amount of photoreactivation.¹²

It would be very difficult (if not impossible) and impractical for the design engineer to try to control the factors mentioned in the preceding paragraph. Therefore, the engineer must account for the anticipated degree of photoreactivation by increasing the UV dose. By increasing the UV dose, the number of organisms initially surviving as well as the magnitude of photoreactivation will be reduced.

2.2 Disinfection Model

The final effluent concentration after irradiation of an organism can be estimated using first order kinetics: ¹³

$$N = N_0 e^{-kIt} \quad (2-1)$$

where:

- N = Density of organisms after exposure to UV (organisms/100 ml)
- N₀ = Initial Density of organisms (organisms/100 ml)
- I = Intensity of UV irradiation (uW/cm²)
- t = Time of exposure (seconds)
- k = Inactivation rate constant (sec⁻¹)

The above equation indicates that by increasing the product of intensity and exposure time to the UV light the number of organisms in the final effluent will be reduced exponentially. The term UV dose is commonly referred to in evaluating the effectiveness of a UV system. The UV dose is simply the product of the intensity and time as shown in the formula below:

$$\text{UV Dose, uW-sec/cm}^2 = (\text{Intensity, uW/cm}^2) (\text{Time, sec}) \quad (2-2)$$

The inactivation rate constant, k, is the slope of the graph of ln(N/N₀) as a function of UV dose. ¹⁴

2.3 Lamps

UV lamps are tubular in shape and similar to standard fluorescent tube lamps; however, the UV lamp tube is typically made of quartz and does not have a coating of phosphorus as does fluorescent lamps. The UV lamps most commonly used for disinfection are filled with low pressure mercury and argon. Figure

2-1 shows a number of UV lamps mounted in removable UV modules. Several UV modules are typically placed in parallel across an open channel in which the wastewater to be disinfected flows through. These UV lamps emit light in which the majority of the rays have a wavelength of 253.7 nm. The available germicidal output of the UV lamp will vary and the manufacturer's literature should be consulted when designing the UV system, but will typically be 20 to 25 percent of the lamp rating for low pressure mercury vapor lamps. The UV output after 100 hours of use should be used in design calculations. UV lamps typically last for 7,000 to 10,000 hours of use. ¹⁵

The operating temperature of the UV lamp itself has a significant effect on the UV output generated by the lamp. It has been determined that the optimum operating temperature for low pressure mercury vapor lamps is 40 degrees Celcius, any deviation from this temperature will change the vapor pressure of the mercury vapor within the UV lamp and result in a lower UV intensity being emitted. The reduction in UV output will be in the range of 1 to 3 percent per degree Celcius change from the 40 degree Celcius optimum temperature. ¹⁶

The spacing of lamps within the reactor is extremely important. Care must be taken to make sure that the lamps are not spaced either too close together or too far apart - either scenario will decrease the efficiency of the UV system and may cause serious problems. If the lamps are spaced too close together, energy will be wasted since the lamps will absorb most of the UV energy instead of it being used to disinfect the wastewater and in addition the energy absorbed by the lamps will increase the operating temperature of the lamps resulting in a decrease of UV output as described above. Lamps that are spaced too far apart will lower the UV dosage and result in reduced disinfection. ¹⁷

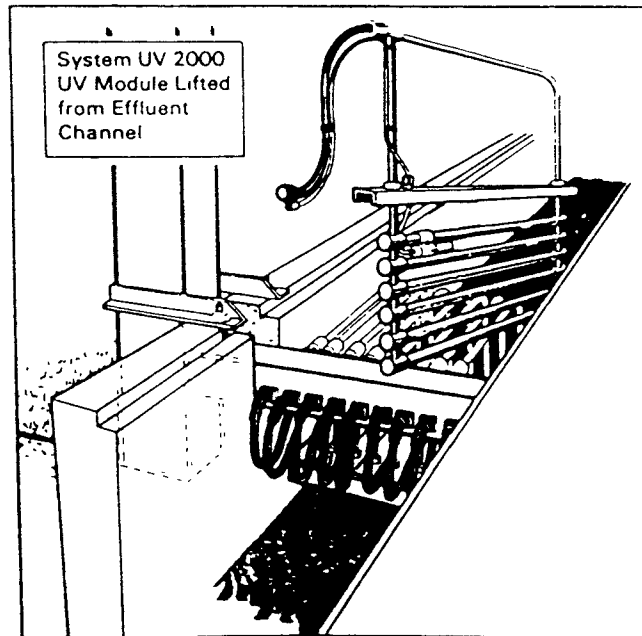
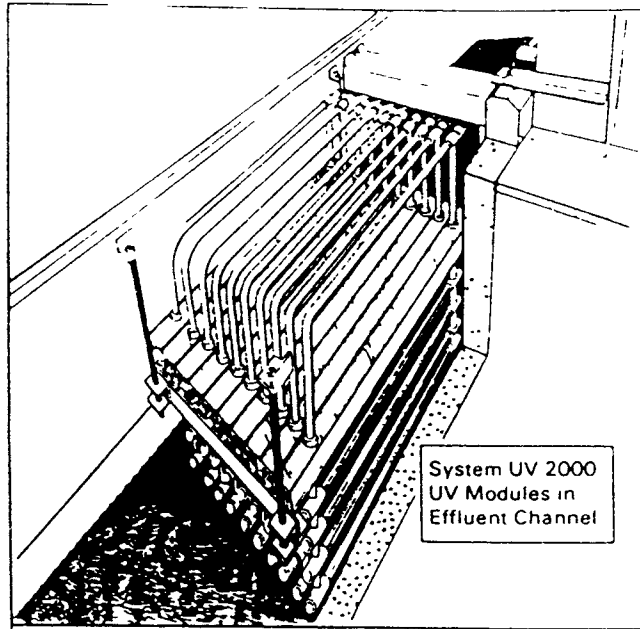

FIGURE 2-1.

BOROUGH OF NEW PROVIDENCE
UNION COUNTY, NEW JERSEY

Schematic of open-channel, modular UV system
(Courtesy of Trojan Technologies, Inc., London,
Ontario, Canada).

The best lamp arrangements are those where the lamps are parallel to the wastewater flow. ¹⁸

2.4 Absorbance

The amount of dissolved organic matter and suspended solids in the effluent wastewater to be treated will effect the amount of UV absorbance of the wastewater. Absorbance is calculated or measured from the Beer-Bouger-Lambert equation: ¹⁹

$$I = I_0 10^{-ad} \quad (2-3)$$

where: I = intensity at distance d ($\mu\text{W}/\text{cm}^2$)
 I_0 = lamp surface intensity ($\mu\text{W}/\text{cm}^2$)
 a = medium absorbance (cm^{-1})
 d = distance from UV lamp to point of Intensity measurement (cm)

Based on past experience, an absorbance value of 0.2 cm^{-1} may be used for design calculation purposes.

2.5 Intensity and Dosing

The UV dose received by the microorganisms is one of the key design parameters for the UV system. Based on past experience, a UV dose of $16,000 \text{ uW-sec}/\text{cm}^2$ is enough to inactivate the microorganisms in the wastewater. Therefore, the reactor and lamp arrangement should be such that a microorganism at the farthest point from a UV lamp will receive a UV dose of $16,000 \text{ uW-sec}/\text{cm}^2$. The size of the reactor will be based on the UV intensity at the farthest point from the lamp and the detention time (time of exposure) in the reactor required to achieve the minimum UV dose of $16,000 \text{ uW-sec}/\text{cm}^2$. ²⁰

Fecal Coliforms (or E. Coli) are commonly used as the standard to measure the effectiveness of any disinfection process. Based on studies, it has been determined that a UV dose of 7,000 uW-sec/cm² is required to destroy fecal coliforms. However, most UV systems are designed to deliver a UV dose of 16,000 uW-sec/cm² which allows for a safety factor of slightly more than 2.0 times. One of the advantages of disinfecting wastewater using UV light is its ability to destroy a wide variety of microorganisms that are not easily destroyed by some other commonly used methods of disinfection. The lethal UV dose required to kill E. coli bacteria (7,000 uW-sec/cm²) has become the standard used in micro-biological studies against which the relative resistance of other microorganisms are measured. Table 2-1 shows the dose requirements and the wide variety of microorganisms that UV light can effectively disinfect. The table shows the relative resistances to UV light of various microorganisms based on E. Coli have a standard value of 1.0 - the resistance of all other organisms are compared to the resistance of E. coli. For example, it takes 10,000 uW-sec/cm² to destroy Salmonella; therefore, it has a value of 1.5 in Table 2-1. ²¹

2.6 Hydraulics of UV Reactors

The proper hydraulic design of the UV reactor is essential to maximize UV disinfection efficiency. The optimal flow condition within the UV reactor is plug flow with minimal longitudinal dispersion. In order to achieve the optimum performance, the design engineer must maximize mixing of the wastewater in the direction perpendicular to flow (transverse dispersion) and minimize mixing in the same direction of flow (axial dispersion). As the UV light

TABLE 2-1. RELATIVE RESISTANCE OF DIFFERENT
MICROORGANISMS TO UV LIGHT²²

| <u>BACTERIA</u> | <u>RELATIVE RESISTANCE</u> |
|-----------------------------|----------------------------|
| B. Subtilis | 1.7 |
| B. Subtilis Spores | 3.3 |
| Clostridium botulinum | 1.6 |
| Corynebacterium diphtheriae | 1.0 |
| Dysentery bacilli | 0.6 |
| Escherichia coli | 1.0 |
| Pseudomonas aruginosa | 1.6 |
| Pseudomonas fluorescens | 1.0 |
| S. typhimurium | 2.3 |
| S. typhosa | 1.0 |
| Salmonella | 1.5 |
| Serratia Marcescens | 0.9 |
| Shigella paraysenteriae | 0.5 |
| Staphylococcus aureus | 1.0 |
| Streptococcus hemolyticus | 0.8 |
| Streptococcus lactis | 1.3 |
| Streptococcus pyrogenes | 0.6 |
| Streptococcus viridans | 0.6 |
| <u>VIRUSES</u> | <u>RELATIVE RESISTANCE</u> |
| Bacteriophage (E. coli) | 1.0 |
| Adenovirus Type 3 | 0.7 |
| Coxsackie AZ | 0.9 |
| Influenza | 1.0 |
| Poliovirus Type 1 | 1.0 |
| <u>MOLDS</u> | <u>RELATIVE RESISTANCE</u> |
| Aspergillus amstelodami | 11 |
| Aspergillus flavus | 15 |
| Aspergillus glaucus | 13 |
| Mucor mucedo | 11 |
| Mucor racemosus (A and B) | 5.3 |
| Penicillium roqueforti | 4.0 |
| <u>PROTOZOA</u> | <u>RELATIVE RESISTANCE</u> |
| Chlorella vulgaris (algae) | 3.3 |
| E. hystolytica | 12 |
| <u>YEASTS</u> | <u>RELATIVE RESISTANCE</u> |
| Baker's yeast | 1.3 |
| Brewer's yeast | 1.0 |
| Saccharomyces cererisiae | 2.0 |

travels through the water its intensity decreases and consequently the disinfecting power is also reduced. Therefore, it is important to make sure all microorganisms experience the same UV dose which means that each microorganism must experience the same average UV intensity and have the same hydraulic detention time. Proper hydraulic design of the reactor will assure that this goal is approximately achieved.²³

The UV reactor will typically have a detention time of less than one (1) minute. Recommended flow velocities are greater than 1 fps. One of the advantages of maintaining high flow velocities is that it tends to inhibit the degree of sleeve fouling of the UV lamps within the reactor.²⁴

Design engineers typically specify various flow parameters to ensure that the UV reactor will produce turbulent plug flow with minimal axial dispersion that will optimize UV disinfection performance.

2.6.1 Aspect Ratio

The engineer should design the UV reactor with the proper Reynold's Number and aspect ratio so as to promote turbulent plug flow with minimal dispersion. The UV reactor should operate with a Reynold's Number, $R_e > 5,000$. However, the designer must make sure that excessive turbulence does not exist at open inlets since this will cause the formation of white water due to dissolved air bubbles. The air bubbles will increase the absorbance characteristics of the water and reduce transmittance of the UV energy, thus reducing disinfection efficiency. The aspect ratio, defined as the reactor length (L) to hydraulic radius (R_h) should be considered when sizing the UV reactor. To achieve

turbulent plug flow, the aspect ratio should be greater than 50. A narrow reactor width with respect to reactor length will promote plug flow characteristics.²⁵

2.6.2 Transverse Dispersion

Mixing in the transverse direction (in the direction perpendicular to flow) should be maximized so that all microorganisms move around a lot so that they all have the same average distance away from the UV lamp. This will cause each organism to experience the same average UV intensity. Adequate transverse mixing can be achieved by designing the system for turbulent flow.²⁶

2.6.3 Axial Dispersion

As mentioned above, axial dispersion in the UV reactor must be minimized so that the flow approaches plug flow conditions. Dispersion, E , has units of cm^2/sec and is a measure of the spread of a group of microorganisms under continuous flow in UV chambers. Short circuiting of the wastewater must be avoided so as to prevent some organisms from passing quickly through the reactor without being adequately disinfected. When plug flow conditions exist, all microorganisms will have the same hydraulic detention time and thus be exposed to the disinfecting light for the same amount of time. An axial dispersion value of zero would be an ideal plug flow situation. Low axial dispersion may be accomplished by minimizing turbulence of the wastewater as it enters and exits the UV reactor and by maximizing the aspect ratio (length/width) of the reactor itself. The amount of axial dispersion will determine the minimal safety factor for light intensity that must be used when

designing the system and will therefore have a direct bearing on the operational costs of the system. For example, if the plug flow reactor has a small amount of dispersion ($E_x < 100 \text{ cm}^2/\text{sec}$), each microorganism will receive between approximately 90 to 110 percent of the germicidal UV dose. In terms of design, this means that that the UV energy at 90 percent of the required UV dose to achieve the design level of disinfection must be provided as a minimum. In this case, there is little energy wasted. However, consider the case where there is a large axial dispersion with considerable short circuiting. Assume that the organisms receive anywhere from 50 to 150 percent of the UV dose. In this case, the design engineer would have to design the UV system such that lamp intensity at 50 percent of the average UV dose would provide the minimal UV dose required to achieve adequate disinfection. This would result in much higher costs due to wasted energy. Proper hydraulic design of the reactor will avoid this problem and allow for efficient economical disinfection.²⁷

2.6.4 Residence Time Distribution (RTD) Curve

The development of Residence Time Distribution (RTD) Curves is an effective means to ensure that the UV reactor will develop turbulent plug flow with minimal axial dispersion. The shape of the typical RTD curve is similar to the Gaussian Standard Normal Distribution Curve. The RTD can be experimentally developed using the salt tracer conductivity method where the conductivity is measured continuously to develop the curve. Once the curve has been developed, one can analyze it to determine if the reactor design is satisfactory.²⁸

The UV manufacturers should provide RTD curves for the range of flows for each reactor design. Based on the RTD curves and calculated dispersion values the design engineer will be able to determine if dispersion is within acceptable limits for plug flow. To obtain near plug flow characteristics, it is recommended that E_x values be below $50 \text{ cm}^2/\text{sec}$. Other indices that can be calculated from RTD curves and that are commonly specified to ensure plug flow conditions include:

- t_p/T : Average velocity short circuiting index should be at least 0.9. Ideal Plug flow value is 1.0.
- t_{50}/T : Average mass short circuiting index should be between 1.0 and 1.1. Ideal plug flow value is 1.0.
- t_{90}/t_{10} : Morrill Index should be less than 2.0.

Where:

- T = theoretical mean detention time (V_v/Q)
- t_{90} = time at which ninety (90) percent of tracer has passed through the reactor
- t_{10} = time at which ten (10) percent of tracer has passed through the reactor
- t_p = time at which the peak concentration of the tracer appears
- t_{50} = time at which fifty (50) percent of tracer has passed through the reactor
- V_v = liquid volume in the UV reactor or UV bank
- Q = total flow

To ensure plug flow the conditions of the above parameters should be satisfied. 29

The average velocity short circuiting index (t_p/T) is used to ensure that short circuiting is not occurring. If the ratio of the time that it takes the peak concentration of the tracer to go through the reactor over the theoretical detention time (T) is less than 0.9, then this tells the engineer that the highest percentage of the influent flow is shooting through the reactor without being exposed to the theoretical UV dosage, since the detention time of the

flow with the peak tracer concentration is less than the theoretical value. A low average velocity short circuiting index means that there are some "dead" spots within the tank where the velocity is very low - these areas receive a very high UV dosage while the majority of the flow shoots through the tank receiving minimal UV irradiation. Under ideal plug flow conditions the t_p/T index would have a value of 1, since the time for the peak concentration of the tracer to appear would be the same time as the theoretical detention time. A t_p/T index of over one indicates that the portion of flow having the largest tracer concentration has a detention time longer than the theoretical time, thus being exposed to a higher UV dose.

The average mass short circuiting index (t_{50}/T) is another method to ensure that near plug flow conditions are present within the UV chamber. If the value of the t_{50}/T index is less than 1, then this indicates to the engineer that more than 50 percent of the wastewater to be treated is not receiving the theoretical UV dosage since the detention time is less than the theoretical detention time. A value of over one indicates that the majority of the wastewater is being exposed to more than the theoretical UV dosage.

The Morrill Index (t_{90}/t_{10}) is a measure of the degree of dispersion or range of the flow. A Morrill Index value of less than 2 indicates that the overall flow is being exposed to relatively the same amount of UV irradiation - the time difference from when 10 percent of the flow appears as compared to when 90 percent of the flow appears is not excessive. This would be represented on a standard curve having a narrow base with a relatively high peak. Whereas a flow pattern having a Morrill Index with a value over 2 would have a wide base with a low peak indicating that the time of flow varied over a

large range of time. A portion of wastewater is traveling very quickly through the reactor having a very short detention time while another portion is traveling very slowly having a long detention time. In terms of UV disinfection efficiency this is a very bad situation, because a large portion of wastewater will be receiving a much lower UV dose than expected while a large part will be receiving a larger UV dose than is required to provide adequate disinfection - the end resulting being an effluent of poor quality. The key to proper hydraulic design is to make sure that as much as possible the entire influent flow is exposed to an equal dosage of UV irradiation.

2.7 Factors that Affect Transmission of UV Light to Microorganisms

To properly design the UV system, the design engineer must also estimate the actual amount of UV light that reaches the organisms that are to be killed. Some of the factors that must be considered to achieve this include:

- the intensity of the UV light emitted from a UV lamp actually decreases as the UV lamp gets older;
- lamp configurations affect the average UV light intensity that is received by the microorganisms for the same level of energy input;
- UV light is absorbed by air and water before it reaches the target organisms as well as by the quartz or non-reactive fluorocarbon polymer surfaces of the actual UV lamps.³⁰

Based on the above, routine plant maintenance should include periodically replaces the UV lamps and thoroughly cleaning lamp surfaces on a regular basis to optimize UV transmission. In addition, reactor designs should evaluate the effectiveness of power consumed to the average UV intensity in the reactor and consideration be given to the absorbance characteristics of the given wastewater to be disinfected.

2.8 Properties of Wastewater to be Disinfected

The engineer must also consider the specific wastewater characteristics that are expected in the wastewater that must be disinfected. The parameters that affect UV system performance the most are initial microorganism concentration, absorbance of UV light by wastewater, and suspended solids concentration. Optimum wastewater conditions to promote the best UV system performance would include a wastewater that readily transmits UV light, has a low initial bacterial count, and low suspended solids concentration with very small particulate matter rather than larger particles.³¹

The wastewater to be disinfected should absorb less than 50% of UV light when passed through a 1-cm cell. Absorbance is measured using a spectrophotometer having a wavelength of 253.7 nm. The absorbance of the wastewater should be monitored routinely by treatment plant personnel as a means of evaluating UV system performance. Since this is usually not a parameter that must be reported for permits, treatment plants usually neglect to obtain absorbance data. Larger particulate matter tends to shield the microorganisms from the UV irradiation resulting in poor disinfection.³²

To achieve the desired degree of disinfection, the wastewater must be exposed to a sufficient intensity of UV light for an adequate period of time. As mentioned above, the amount of UV light absorbed before reaching the target microorganism will greatly affect UV disinfection efficiency. Before reaching the wastewater, the UV light generated by the lamp must be transmitted through a media. The two most common medias are quartz or non-reactive fluorocarbon

polymer, because they transmit UV light efficiently. The quartz media is used in UV systems where the UV lamps are submerged in the water - quartz sleeves surround the UV lamps keeping the lamps dry (see Figure 2-1). In the other commonly used system, the water to be disinfected flows through non-reactive polymer tubes and the UV lamps disinfect the wastewater from the outside transmitting the UV light through the tubes (see Figure 2-2). In either system, the media will absorb a certain amount of UV light reducing the UV intensity available to kill the bacteria in the wastewater.³³

In addition to the media absorbing part of the UV light, any coating or film that develops on the surface of the media will also reduce the effective UV light reaching the microorganisms for actual disinfection. In the non-submerged system, dust can collect on the outside surfaces of the polymer tubes reducing UV intensity. In both the submerged and non-submerged systems inorganic scale can form on the wetted quartz or polymer surfaces or biofilm may develop on either surface. Therefore, it is imperative that these surfaces be kept clean so that UV intensity is not reduced. For these reasons, conscientious plant maintenance is essential to keep the UV system operating efficiently and effectively.³⁴

2.9 Operation and Maintenance

The daily operation and required routine maintenance of the UV disinfection system is less work for plant personnel when compared to other methods of disinfection such as chlorination or ozonization. However, the UV system does require some supervision and maintenance to keep the system operating in an

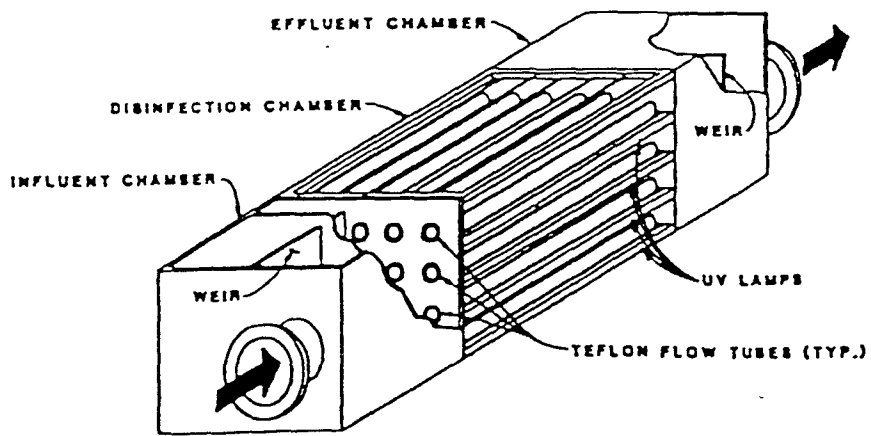
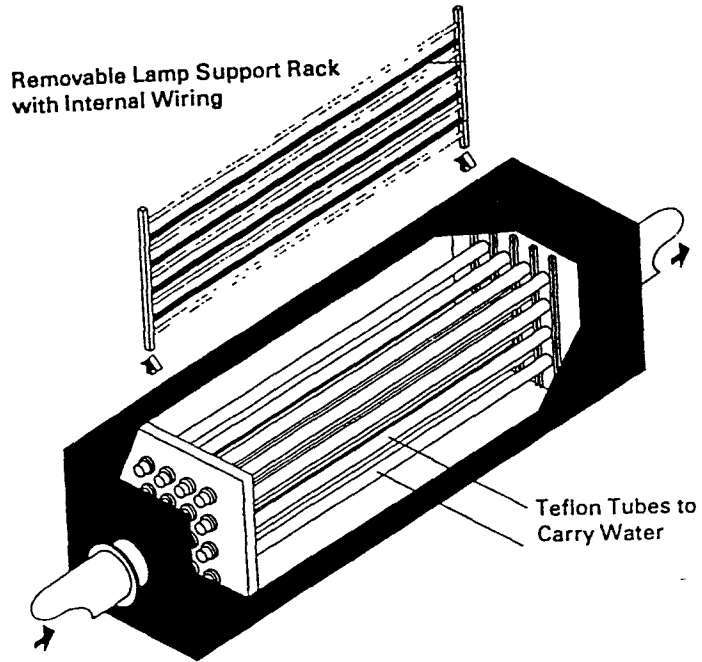

FIGURE 2-2. EXAMPLE OF UV SYSTEM UTILIZING TEFLON TUBES (COURTESY OF ULTRAVIOLET TECHNOLOGY, INC., RANCHO CORDOVA, CALIFORNIA).

efficient manner. Without proper operation and maintenance of the system, the effluent quality will quickly deteriorate.³⁵

2.9.1 Process Control

During routine disinfection operations, the only variable that the plant operator must be concerned with is the amount of irradiation to supply to the wastewater and which units are to be put on-line. Most UV systems are designed with flexibility as to how many lamps are to be used and how many channels. Once the desired UV dose has been determined, the operator must only monitor the system to ensure that proper disinfection is being achieved and to be alert to when a change in the current operating configuration of the system is required.

Many of the existing UV systems throughout the country were designed with automatic controls. The purpose of the automatic control systems is to adjust the amount of irradiation based on the flow rate. At periods of low flow and high detention times, it may be desirable to reduce the number of lamps in operation in order to reduce disinfection costs. Of the six UV disinfection systems at the wastewater treatment plants analyzed in the studies by Sam White, E. Barcus Jernigan and Albert Venosa, five were initially designed with automatic controls to adjust the amount of UV dose used to treat the wastewater at any given time. However, the use of automatic controls has since been eliminated at four of these plants for various reasons.³⁶

The reasons for converting to manual control varied. Some of the control systems did not work as designed; some were not reliable, were subject to frequent malfunctions due to complexity of the system and difficulty in getting required service; while another had many electrical problems that resulted in several electrical fires.³⁷

Based on the experience of the above treatment plants with use of automatic controls, one may conclude that the use of automatic controls should be avoided. However, it is important for the design engineer to consider ways to reduce the required power consumption for disinfection and thus save money for the treatment plant. However, based on the problems encountered in the facilities analyzed above, it is essential that the design engineer use extreme care and caution to ensure that any automatic control system used on UV systems be reliable, easily maintained by plant personnel, have a proven track record at other facilities, and that replacement parts and instruments are readily available. One simple inexpensive alternative to the more complex and costly micro-processor control systems would be to install a timer that would adjust the number of lamps and/or channels in operation to reduce UV output during periods of low flow at a selected period every day to match the diurnal flow pattern.³⁸

The other aspect of process control that the operator must not ignore in order to achieve a consistently high degree of efficient disinfection are laboratory tests and accurate records. Accurate record keeping and frequent lab analysis will allow the operator to determine if the selected power levels (UV dosage) are correct. Some of the tests that should be run on a routine basis include:

- Fecal Coliform entering the unit
- Fecal Coliform exiting the unit
- TSS entering the unit
- Absorbance or Transmittance of wastewater
- Flow Rate at time of sampling
- Number of UV lamps in operation at time of sampling

Routine testing of the above parameters and accurate record keeping in regards to maintenance of the UV system, will allow accurate and concise process control decisions by the operator to achieve the most efficient level of disinfection. Most UV systems provide in-place UV intensity meters to monitor the intensity of UV light being delivered to the microorganisms within the wastewater; however, based on studies, these sensors have proven to be unreliable and therefore should not be used to make process control decisions. These sensors have proven useful in alerting operators when illumination is lost from a entire bank of lights.³⁹

2.9.2 Maintenance

A maintenance schedule for the UV disinfection system should be developed and followed to ensure that the system is properly maintained. Proper maintenance of the system is essential for efficient disinfection. The major maintenance tasks that must be performed on a routine basis include:

- routine cleaning of the system;
- periodic replacement of lamps, ballasts, and quartz or non-reactive surfaces;
- periodic replacement or repair of electrical components such as meters, relays, and indicator lights;
- annual cleaning, overhaul, and repair of the system.⁴⁰

A log book should be kept to note the date and elapsed time when all of the maintenance activities are performed and to exactly which units. The frequency of the maintenance activities will vary greatly among wastewater treatment plants depending on the wastewater characteristics and the type of UV system; therefore, frequency of each maintenance activity should be determined by operator experience.

Keeping the UV lamps clean is very important to maintain a high degree of disinfection. Any scum or dirt on the UV lamp will reduce the intensity of the UV light available to kill the microorganisms in the wastewater. There are three basic techniques used to clean UV systems: 1) ultrasonics; 2) mechanical wipers; and 3) chemical cleaning. The method of chemical cleaning is recommended by most manufacturers' of UV systems and is most commonly used by treatment plant operators. Chemical cleaning is often used in conjunction with either ultrasonics or mechanical wipers. The use of ultrasonic cleaning or mechanical wipers in conjunction with chemical allows the time period between chemical cleanings to be increased. ⁴¹

2.10 Ventilation

When designing the UV system, the engineer must be aware of the importance to provide adequate ventilation for the electrical components of the UV system. Three of the six case study facilities analyzed by White, Jernigan, and Venosa experienced electrical problems caused by insufficient ventilation of the heat-generating electrical components. The excessive heat built-up within the

electrical equipment caused equipment failures. To alleviate such over-heating problems, ventilating fans and louvered vents with sufficient capacity should be installed to avoid excessive build-up of heat - services of a qualified electrical engineer should be sought to ensure proper design of the ventilating system.⁴²

2.11 Cost Analysis

The costs associated with the operation and maintenance of the UV disinfection system can be divided as such:

- man-hours for routine maintenance
- replacement parts and supplies
- power utilization
- man-hours for analytical work
- costs for chemicals used for cleaning

The municipal wastewater treatment plant at Albert Lea, Minnesota was constructed in 1983 with a design flow of 12.5 MGD. This facility is one of the largest WWTP's utilizing UV light for disinfection. UV radiation has proven to be very cost effective as well as consistently providing a high degree of disinfection. Disinfection operating costs have averaged only \$0.02 per 1,000 gallons of treated effluent. This compare very favorably to disinfection estimates for chlorination/dechlorination, \$0.04 to \$0.08 per 1,000 gallons or ozonization with estimates of \$0.10 to \$0.15 per 1,000 gallons. The routine operation and maintenance costs at the Albert Lea facility were that for energy and lamp replacement. Other equipment such as quartz sleeves, lamp ballasts and seals are replaced as required, but not on a routine basis.⁴³

3.0 NEW PROVIDENCE WASTEWATER TREATMENT PLANT - CASE STUDY

3.1 Facility Description and Brief History

The New Providence Wastewater Treatment Plant is located in Union County, New Jersey (see Figure 3-1a) and provides sanitary sewer service for the Borough of New Providence. The facility provides secondary treatment of the wastewater before being discharged to the Passaic River. The treatment plant consists of a primary clarifier/leveling reservoir, two trickling filters, one final clarifier, disinfection facilities and a pumping station. No sludge handling facilities are provided at this WWTP. All the solids collected during the treatment process are pumped along with up to 1.5 MGD of raw sewage to the City of Summit sanitary sewer system for treatment at the Elizabeth Joint Meeting Facility.⁴⁴

Prior to 1970, the New Providence Facility provided only primary treatment. The facility consisted of one primary settling tank and chlorination facilities which were only used to handle wet weather flows that exceeded 1.5 MGD. The facility also included a pumping station that was and still is used to transfer raw sewage to the City of Summit sanitary sewer system for treatment at the Elizabeth Joint Meeting facilities. The New Providence WWTP is allowed to and on average pumps 1.5 MGD of raw sewage to the City of Summit sanitary sewer system. Any flows in excess of 1.5 MGD must be treated on site at the New Providence Facility. However, a minimum flow of 0.3 MGD is required to allow the biological matter in the trickling filter to maintain its growth and not die due to lack of nutrients and water.⁴⁵

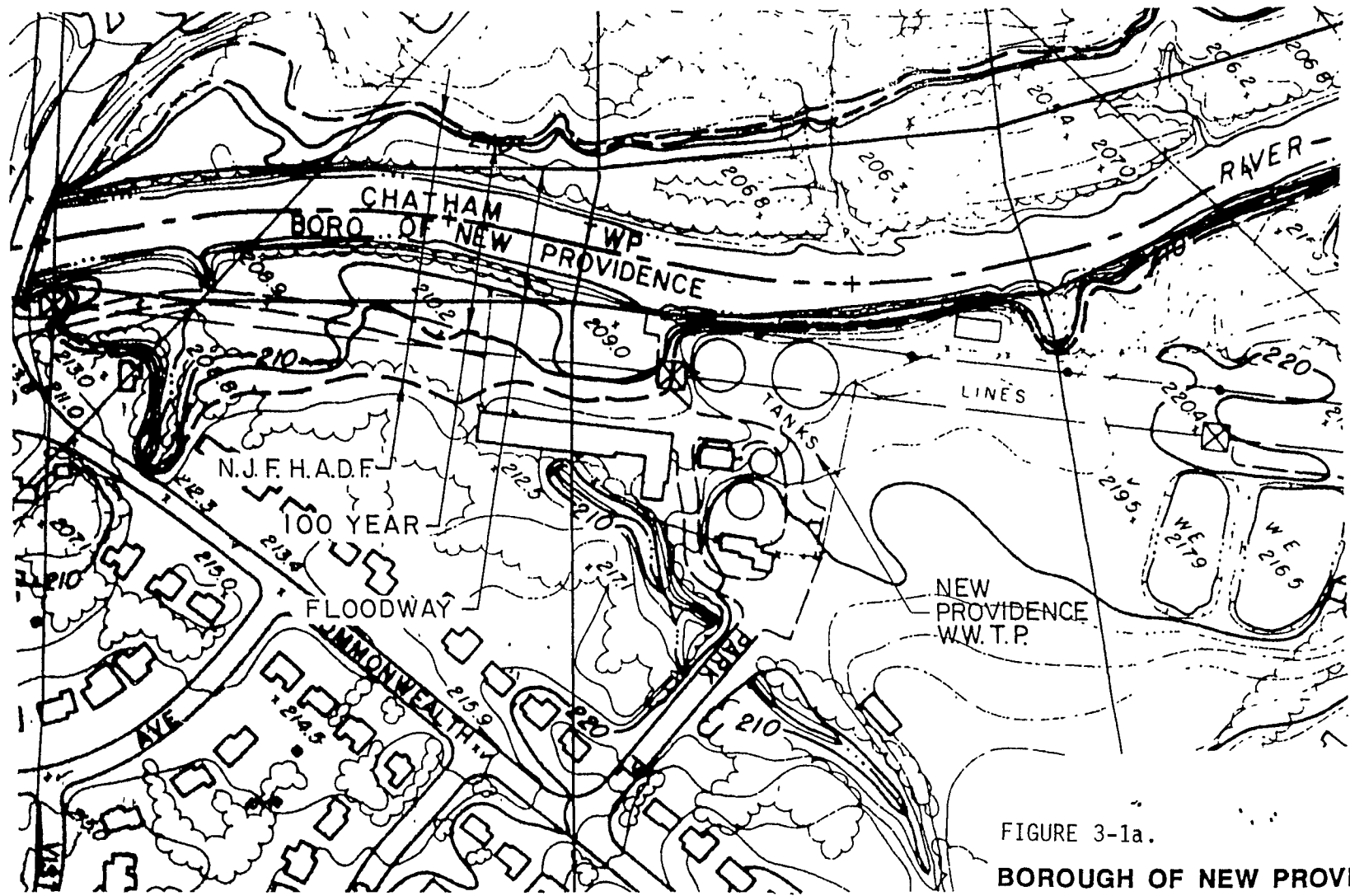



FIGURE 3-1a.
BOROUGH OF NEW PROVIDENCE
 UNION COUNTY, NEW JERSEY
W.W.T.P. SITE PLAN

SCALE: 1"=200'

COURTESY OF: **Elson T. Killam Associates, Inc.**
 Environmental and Hydraulic Engineers
 27 Bleeker Street Millburn, New Jersey 07041 

The sanitary sewer collection system for the Borough of New Providence is in very poor condition which allows significant amounts of infiltration to enter the system during storm events. Therefore, the sanitary sewer system actually acts as a combined sewer system. For this reason, the most recent major upgrade of the facility in 1970, allowed for a great deal of flexibility in order TO accommodate the large range of flows encountered at the New Providence WWTP. The 1970 upgrade included the construction of two trickling filters to provide biological treatment. During dry weather flows the two trickling filters operate in series at low organic loading rates and thus provide a very high degree of treatment while still keeping the biological growth on the filters adequately moist at flow rates of 300,000 gpd. However, during wet weather flows the plant automatically switches over to parallel operation of the trickling filters to handle the additional flow while still maintaining adequate levels of treatment.⁴⁶

3.1.1 New NJPDES Permit Requirements

The decision to switch the method of disinfection from chlorine to UV light was initiated by the New Jersey Department of Environmental Protection and Energy (NJDEPE) making the Borough of New Providence's discharge permit more stringent. The Borough of New Providence was notified by NJDEPE that as of May 1, 1988 the Borough's WWTP would be required to comply with more stringent effluent requirements than its present NJPDES Permit. One of the changes in the May 1, 1988 Permit was that the chlorine residual of the effluent discharged to the Passaic River had to be reduced greatly or eliminated. In order to comply with the requirements of this permit, the Borough of New Providence considered the construction of either a UV disinfection system or

chlorination/dechlorination facilities. Killam Associates, consulting engineers for the Borough of New Providence, analyzed the feasibility of both UV light and a chlorination/ dechlorination system to provide the necessary degree of disinfection in order to comply with the new NJPDES Permit.⁴⁷

3.1.2 Disinfection Alternatives

Disinfection of wastewater at the New Providence WWTP in the past was accomplished by use chlorine. However, disinfection with chlorine produced a chlorine residual in the plant effluent at levels above those stipulated in the new May 1, 1988 NJPDES Permit. As mentioned in the previous section, Killam Associates investigated the use of UV radiation and chlorination/dechlorination as alternative disinfection options for the New Providence WWTP.

3.1.2.1 Chlorination/Dechlorination

Three different methods of dechlorination were analyzed: 1) sulfur dioxide (SO₂), 2) granular activated carbon and 3) use of a holding pond. Upon review of the existing dechlorination facilities and the site conditions at the New Providence WWTP (very limited space), sulfur dioxide was determined to be best method of dechlorination. Sulfur dioxide was more widely used than the other methods, was much more cost effective and the easiest to use. The large space requirements for the holding pond dechlorination option immediately ruled out this alternative for the New Providence WWTP, since there was not sufficient open land for the construction of a large holding pond. Sulfur dioxide is applied to the wastewater using equipment very similar to that typically used to chlorinate wastewater.⁴⁸

A study of 31 wastewater treatment plants employing dechlorination systems in California observed that there was some bacterial aftergrowth following dechlorination. This was observed in all three methods of dechlorination. The increase in microorganisms was observed primarily in the total coliform group. It was concluded that the increase in microorganisms was not caused by reactivation of injured bacterial cells, but rather propagation of surviving bacteria within the dechlorination chamber. Studies reported in "Progress in Wastewater Disinfection Technology" on bacteriological aftergrowth indicate that the majority of growth is not of pathogenic bacteria. For example, studies revealed that Salmonella and streptococci concentrations did not increase significantly following dechlorination.⁴⁹

3.1.2.2 Ultraviolet Light (UV)

When ultraviolet light is used to disinfect the wastewater there is no addition of chemicals and therefore there is no residual discharged to the receiving waterway. The lack of any harmful residuals being discharged that could have a detrimental impact on the aquatic ecosystem is one big advantage of the use of UV.

The ultraviolet light disinfects the wastewater by transmitting a wavelength that kills the microorganisms. The ultraviolet radiation (wavelength of 253.7 nm) is absorbed by the nucleic acids in the microorganisms damaging or altering the genetic information in the DNA of the cell that causes the cell to be unable to replicate and eventually results in the death of the cell. For more information on the mechanism and theory of UV disinfection, refer to Chapter 2.

Photoreactivation is a concern when using UV as the means of disinfection. Photoreactivation is the phenomena in which cells damaged by exposure to UV light are able to replicate and are repaired when exposed to light energy at wavelengths between 340-380 nm. Based on studies, the degree of photoreactivation of damaged cells is in the range of one order of magnitude of the density of coliform in the effluent. The practical implications of photoreactivation deserve more study and research to learn more about how this phenomenon affects the overall level of disinfection achieved. Some studies have shown that certain pathogenic microorganism do photoreactivate.⁵⁰ See Section 2.1.1 for a more in depth discussion on the phenomenon of photoreactivation.

3.2 Design Criteria

3.2.1 Design Flow

The New Providence sewage treatment plant is designed to treat a minimum average daily flow of approximately 300,000 - 400,000 gallons per day which is the amount required to maintain an active biological slime on the trickling filters. The plant is designed to treat a maximum wet weather flow of 6.0 MGD (2.0 MGD through each of the three UV channels). In addition to these flows, a total of 1.5 MGD of raw sewage may be pumped into the city of Summit sanitary sewer system for treatment at the Elizabeth Joint Meeting facilities. Any flows in excess of 1.5 MGD, must be treated at the Borough's WWTP.⁵¹

3.2.2 Design Parameters

The UV system design parameters are summarized in Table 3-1. The anticipated influent conditions for the UV reactor of the key parameters are listed as well as the fecal coliform effluent limits that indicate the degree of disinfection that must be achieved by the UV system. The performance and hydraulic characteristics that the proposed UV reactor had to achieve are also summarize in Table 3-1.

Excerpts from the NJPDES Permit for the New Providence WWTP have been included in Appendix A showing the effluent limits that the facility must meet.

3.3 Description of UV System

The ultraviolet disinfection system installed at the New Providence WWTP is Model No. 70UV2000 as manufactured by Fischer & Porter. The system consists of ultraviolet lamps mounted on rack assemblies that are placed side-by-side in the concrete channels (see Figure 3-1b). The UV lamp racks are submerged in the open concrete channel in which the wastewater flows. The lamps are oriented parallel to the flow of wastewater in order to provide the optimum degree of disinfection.⁵²

The UV radiation is provided by low pressure mercury vapor lamps that are surrounded by a quartz sleeve and water tight electrical connections - the complete package being called a lamp assembly. The lamp assemblies are mounted in a rack which are immersed in the flowing wastewater to provide disinfection. The UV lamps generate light having a wavelength of 254 nm.

TABLE 3-1
UV SYSTEM DESIGN PARAMETERS⁵³

1. UV SYSTEM INFLUENT CONDITIONS:

- a. Suspended Solids = 30 mg/l
- b. BOD = 30 mg/l
- c. 50% ultraviolet transmission at 254 nm
- d. Water Temperature Range = 50 to 75 deg. F
- e. Air Temperature Range = -20 to 110 deg. F
- f. Flow Rate through each channel (3 channels total)
 - Storm Peak 2.0 MGD (1,390 gpm)
 - Dry Weather Min. 0.1 MGD (70 gpm)
 - Dry Weather Avg. 0.3 MGD (208 gpm)
- g. Fecal Coliform = 100,000/100ml sample or greater

2. EFFLUENT CONDITIONS:

- a. 200 Fecal Coliforms/100 ml, geometric mean for samples collected daily in any 30 consecutive day period
- b. 400 Fecal Coliforms/100 ml, geometric mean for samples collected in any 7 consecutive day period

3. ULTRAVIOLET REACTOR PERFORMANCE CHARACTERISTICS:

- a. Dose after one (1) year = 24,000 uwatt. sec/cm²
- b. Arc Length Per Bank = 3132 inches
- c. Retention Time = 6.6 seconds

4. ULTRAVIOLET REACTOR CHARACTERISTICS:

The equipment manufacturer shall furnish a set of Residence Time Distribution (RTD) curves for a number of flow conditions. The RTD curves for the following indices must be submitted and meet the following conditions:

- a. $t_f/T > 0.5$
- b. $t_{90}/t_{10} < 2.0$
- c. $t_p/T > 0.9$
- d. $t_{50}/O = 0.9$ to 1.1
- e. $E < 500 \text{ cm}^2/\text{sec}$
- f. $d = 0.02$ to 0.05

TABLE 3-1 (CONT.)

UV SYSTEM DESIGN PARAMETERS (CONT.)

Where:

- t_f = time at which the tracer first appears
- T = theoretical mean retention time (V_v/Q)
- t_{90} = time at which ninety (90) percent of tracer has passed through the reactor
- t_{10} = time at which ten (10) percent of tracer has passed through the reactor
- t_p = time at which the peak concentration of the tracer appears
- t_{50} = time at which fifty (50) percent of tracer has passed through the reactor
- O = the meantime (centroid) of the curve
- E = dispersion coefficient ($\text{length}^2/\text{sec}$)
- d = dispersion number
- V_v = liquid volume in the UV reactor or UV bank
- Q = total flow

These coefficients are to be calculated as described in the EPA Design Manual EPA/625/1-86/021.

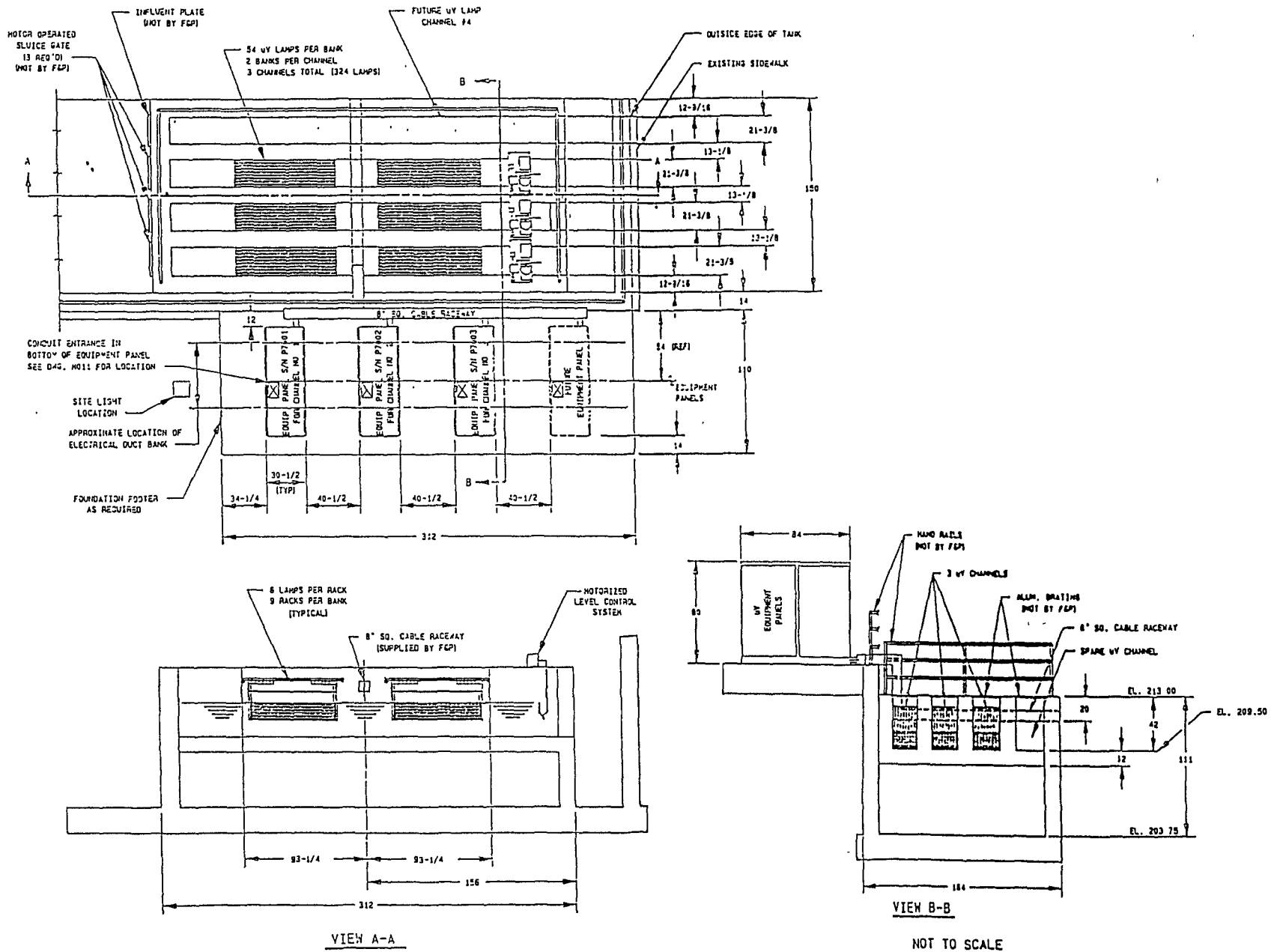

FIGURE 3-1b. ULTRAVIOLET FACILITIES AT THE NEW PROVIDENCE WTP (COURTESY OF FISCHER & PORTER, WARMINSTER, PENNSYLVANIA).

The UV system at the New Providence WWTP consists of three (3) channels that each contain two (2) banks of UV lamps. Each bank contains nine (9) removable lamp racks in which six (6) UV lamps are mounted. Therefore, each UV bank contains 54 individual UV lamps. Each UV lamp is 64 inches long and has a quartz sleeve to protect it from the water and to provide a water tight assembly.⁵⁴

The UV lamps are spaced at 2.375 inches apart on center. Each UV channel is 21.375 inches wide and has a depth of 44 inches. The optimum depth of water is 14.25 inches and this level is maintained by a level controller. It is important that the optimum depth of water is achieved on a consistent basis. If the water level is too high a large portion of wastewater will not receive sufficient UV dosage since the wastewater is too far away from the UV lamps.⁵⁵

3.3.1 System Control

The Fischer & Porter UV system was designed with automatic control of the UV channels and banks based on the influent flow to achieve the highest degree of disinfection efficiency. The system is controlled by use of a Programmable Logic Controller (PLC) which sends signals to automatically open and close slide gates, turn lamp banks on and off, and to provide overall control of the system based on the amount of flow.⁵⁶

The UV system at the New Providence WWTP was initially programmed to operate with one channel and one UV bank in service at flows up to 0.5 MGD. To operate the system in automatic mode, the operator must initially select the lead

channel by turning a switch and place the system in automatic mode, and then the PLC will take over operation of the system. When flows exceed 0.5 MGD the second bank in the lead channel will be energized to provide additional disinfection. When flows reach a level of 2.0 MGD the slide gate in the first lag channel will open and both UV banks in this channel will be energized so that a two channels and four banks will be providing disinfection. If flows exceed 4.0 MGD the slide gate for the second lag channel will open and remain in the full open position and both UV banks in the channel will be energized. Upon decreasing flows the slide gates and UV banks will be deenergized.⁵⁷

Switches at the control panel allow the operator to operate the UV system either automatically using the PLC or manually. The hand-off-auto switch allows the operator to control the individual lamp racks within each UV bank (9 lamp racks per bank). For manual operation the switch is placed in the "hand" position to turn the rack on and in the "off" position to turn the rack off and to signal to the PLC that this rack is out of service. The switch is placed on "auto" when the system is to be run automatically.⁵⁸

3.3.2 Elapsed Time Meter

An elapsed time meter is provided to monitor the amount of hours each UV bank has been used. The UV lamps should be replaced after every 7500 hours of operation. The UV lamps should be cleaned on a routine basis to prevent loss of UV intensity due to build up of debris on the quartz surface of the lamp. The individual lamp racks are removable which allows for easy cleaning of the UV lamps without taking the entire bank out of operation.⁵⁹

3.3.3 UV Intensity Monitor

The UV system provided by Fischer & Porter includes a UV intensity meter to assist the operator in monitoring the UV dosage being received by the microorganisms. The meter is an analog meter which is calibrated to read 100% with new UV lamps and in a controlled clean effluent. A significant reduction in the UV intensity meter reading alerts the operator that disinfection performance may be degraded. The operator should then investigate the reason for the lower UV intensity reading. A low reading may indicate excessive build-up on the surface of the lamps, effluent with a large amount of turbidity, or many other causes that could reduce the UV intensity.⁶⁰

3.4 Analysis of UV System Performance

The following data should be available in order to accurately evaluate the performance of any UV system:

- Fecal coliform entering the unit
- Fecal coliform exiting the unit
- TSS entering the unit
- Absorbance (or percent transmittance) of wastewater
- Flow rate at time of sampling
- Number of UV lamps in operation at time of sampling⁶¹

All samples should be grab samples and taken at the same time. Unfortunately, most treatment plants do not gather all of the above data on a regular basis, since this information is not required for regulatory reports. In addition, when samples are taken they are often not grab samples or all the samples and information does not correspond to the same time period.

The situation at the New Providence WWTP is typical to what was described above. The information most useful to properly evaluate the performance of the UV disinfection system is limited. Absorbance and/or transmittance data of the wastewater is rarely taken and the samples taken for the above parameters are often taken at different times, thus decreasing the accuracy of any correlations developed between different parameters as they relate to UV performance.

The Fischer & Porter UV system has been in operation at the New Providence WWTP since July 1989. Over two years worth of data was analyzed in evaluating the performance of UV disinfection system. The raw data used to develop the graphs is located in Table 3-2 (see Appendix B). All the graphs for the New Providence WWTP are located in Appendix C. In the majority of graphs, the extremely high effluent fecal coliform concentrations were not included in order to more accurately depict the correlation of the various wastewater parameters to the typical range of fecal coliform concentrations. The high values can be looked at on an individual basis. The following sub-sections discuss the correlations or lack of between many typical wastewater parameters and UV disinfection performance.

3.4.1 Flow

Six graphs were developed relating various flows to effluent fecal coliform concentrations. The extremely high effluent fecal coliform values were not included in Figures 3-1 through 3-4 in order to more accurately show the typical range of effluent fecal coliform concentrations. The higher fecal coliform values were included in Figures 3-16 and 3-17.

3.4.1.1 Flow Design Values

The New Providence WWTP UV disinfection system was designed to disinfect 0.3 MGD to 0.4 MGD through each of the three UV channels during dry weather average flows. The design storm peak flow was 2.0 MGD through each UV channel. It should be noted that there are two UV banks contained in each channel. The total plant average dry weather design effluent flow was 0.9 MGD to 1.2 MGD and the total plant average peak storm design flow was 6.0 MGD. From Table 3-2, the average plant effluent flow and instantaneous flow through the UV system was 0.60 MGD and 0.827 MGD, respectively. Both these average values are below the dry weather design average. However, the maximum effluent flow and instantaneous flow measurements (3.27 MGD and 3.768 MGD, respectively) both exceeded the dry weather average flow design value, but were well below the peak storm design values.

3.4.1.2 Fecal Coliform and Flow Correlations

Figures 3-1 and 3-2 give a more accurate representation of the correlation between flow and UV disinfection performance, since the instantaneous flow at the time the fecal coliform sample was taken was used. From Figure 3-1, Effluent Fecal Coliform Vs. Instantaneous Flow, it appears that flows above 0.9 MGD (the dry weather average flow) caused a reduction in the disinfecting performance of the UV system. All but one of the samples that exceeded the average monthly maximum value for fecal coliform (200 counts/100 ml) occurred at flows greater than 0.9 MGD.

Based on analyzing the data presented in Figure 3-2, Effluent Fecal Coliform Vs. Instantaneous Flow Per UV Bank in Operation, it can be concluded that the UV system consistently met the maximum monthly average permit effluent fecal coliform limits when the flow per UV bank was less than or equal to 0.2 MGD (dry weather average flow per channel is 0.3 MGD). Only one effluent fecal coliform sample whose flow was less than 0.2 MGD exceeded the monthly permit average limit. At instantaneous flows per UV bank below 0.3 MGD, all but three points met the monthly permit limit of 200 fecal coliforms per a 100 ml sample.

Figure 3-3 shows the relationship between effluent fecal coliform concentrations in comparison to the effluent plant flow. The graph shows that there were four effluent fecal coliform points that exceeded the maximum weekly permit limit of 400 coliforms per 100 ml sample when the plant flow was less than 0.9 MGD which is the dry weather average design flow.

Figure 3-4 shows the relationship between effluent fecal coliform concentrations in comparison to the effluent flow per UV bank in operation. When the flow per UV bank was below 0.3 MGD, only three points exceeded the maximum weekly average permit limit for fecal coliform concentrations.

The fecal coliform concentration was plotted against the effluent plant flow in Figure 3-16. All fecal coliform values were included in this graph, whereas the highest values were excluded in Figure 3-3. This graph shows that three high fecal coliform concentrations occurred at effluent plant flows of less than 0.3 MGD, which is in contradiction to the general correlation seen on the previous four graphs. However, the four other high points did occur when the

plant flow was in excess of 1 MGD which does agree with the findings of the previous graphs.

Figure 3-17 also included all fecal coliform values and depicts the correlation of effluent fecal coliform concentrations with the instantaneous flow per UV bank in operation. In general, it appeared that as the flow increased the fecal coliform concentration also increased. However, there were three high fecal coliform values that occurred at instantaneous flows below 0.2 MGD which is below the average dry weather design value per UV channel of 0.3 MGD.

In summary, there seems to be a definite positive correlation between flow and fecal coliform concentration. When the flow was below the average dry weather design flows the fecal coliform concentration was fairly consistently below the maximum fecal coliform monthly average of 200 counts/100 ml sample. The vast majority of permit violations occurred when the plant flows exceeded the average dry weather design flows.

3.4.1.3 Enterococci Organisms and Flow Correlations

Figure 3-12, graphically depicts the correlation between effluent enterococci counts and instantaneous flow through each UV Bank. Based on this data, there seemed to be a definite correlation between disinfection efficiency and flow through each UV Bank. At flows above approximately 0.25 MGD, all but one of the enterococci values failed to meet the maximum permit limit. At lower flows, the enterococci counts were more consistently in compliance with applicable permit limits.

Figure 3-13, graphically depicts the correlation between effluent enterococci organisms and effluent plant flow per UV channel in operation. The majority of high enterococci counts occurred at flows exceeding approximately 0.17 MGD. While at lower flows, the enterococci counts were more consistently in compliance with the permit limits.

It was quite evident from analyzing the two graphs, that the New Providence WWTP has had some difficulty complying with the established enterococci limits. However, during the same period, they have fairly consistently been in compliance with their effluent fecal coliform permit limitations.

3.4.2 Suspended Solids

No correlation was observed between effluent suspended solids concentrations and the effluent fecal coliform count (see Figure 3-5). This was not surprising, since all of the effluent suspended solids concentrations were well below 30 mg/l which is the value that the UV system was designed. The effluent suspended solid concentrations on the graph varied from 4 mg/l to 23 mg/l. The average suspended solids concentration was 12 mg/l and the permit limit for the New Providence WWTP is 24 mg/l. At higher suspended solids concentrations, one would expect to see a positive correlation between fecal coliform counts and suspended solids.

According to studies by S. White, E. Barcus and A. Venosa as well as others, high suspended solid concentrations will reduce the disinfection efficiency of the UV system. This is caused by the high concentration of suspended solids actually shielding the microorganisms from the UV rays. The percent

transmittance (or absorbance) along with the concentration of suspended solids greatly affects the intensity of UV light actually reaching the microorganisms, consequently the level of fecal coliforms in the disinfected effluent.⁶²

Blaine Severin explained in his article entitled "Ultraviolet Disinfection for Municipal Wastewater" that the concentration of suspended solids will affect the degree of disinfection for the following reasons:

- 1) Clumps of organisms skew the kinetic response due to the method by which survival is measured, for example, the plate count method.
- 2) Organisms in a clump will tend to shadow or protect each other from the lethal UV rays.
- 3) Particles will scatter UV light.⁶³

Studies on the effects of suspended solids and clumps of particulate matter by Oliver and Cosgrove found that sonification of wastewater to break up clumps of particulate matter greatly increased the disinfection efficiency of UV systems. Similar studies performed by Qualls and Johnson determined that clumps of particulate matter larger than 70 μm resulted in increased levels of fecal coliform in the disinfected effluent on the order of magnitude of three or four log units. From this it can be concluded that major obstacles have a large effect on the disinfection efficiency. In addition to the amount of suspended solids being an important parameter to monitor, the size of clumps making up the total suspended solids concentration is also extremely important as illustrated by the findings of Qualls and Johnson.⁶⁴

In another study by Qualls and his colleagues, it was concluded at one WWTP that the protection of coliforms associated with larger suspended particles was

a major factor limiting the degree of UV disinfection of the effluent wastewater. When particles having a diameter of about over 8-um were removed by filtration, the UV radiation was able to essentially disinfect the wastewater effluent completely where substantial numbers of microorganisms remained in the unfiltered samples. The conclusion reached from this study was that the variation in the content of suspended particles (i.e. distribution of size of particles) could explain the major differences in the dose-survival rates in different effluent samples.⁶⁵

An in depth study at the Hyrum, Utah Municipal Wastewater Treatment Plant found a significant inverse correlation between suspended solid concentration and UV disinfection efficiency. This study also concluded that as the percent transmittance of the wastewater increased so did the disinfection efficiency of the UV system. Based on this, the use of turbidity measurements were recommended as a excellent parameter to monitor UV disinfection efficiency. No data on turbidity measurements was available for the New Providence WWTP. A limited amount of percent transmittance data is presented in the following section.⁶⁶

Based on studies performed by R. Qualls and his colleagues, they concluded that the correlation between UV disinfection efficiency was greater with suspended solids rather than with turbidity measurements. Suspended solids concentrations are more applicable because of the importance of the larger particles in determining the mass of the suspended solids, while turbidity measurements are related to a cross-sectional area of the particle which emphasizes the large number of smaller particles. The installation of a 10-um reusable nylon screen to remove the larger suspended particulates would be a

simple inexpensive way for wastewater treatment plants to improve the efficiency of their UV disinfection system.⁶⁷

3.4.3 Transmittance

The laboratory facilities at the New Providence WWTP do not have the required equipment to perform absorbance or percent transmittance testing and since these parameters are not required as part of their NJPDES permit these parameters are not typically tested. However, prior to designing the proposed UV system, several samples were sent to an independent laboratory to measure the percent transmittance of the wastewater at the New Providence WWTP.⁶⁸ The results of these tests appear below:

| <u>Date</u> | <u>Sample #</u> | <u>% Transmittance</u> |
|----------------------|-----------------|------------------------|
| Oct. 30, 1987 | 1 | 57.5 |
| Oct. 30, 1987 | 2 | 55.5 |
| Dec. 14, 1987 | 1 | 52.0 |
| <u>Dec. 14, 1987</u> | <u>2</u> | <u>56.0</u> |
| AVERAGE | | 55.2 |

The average percent transmittance of the four samples tested was 55.2%. These results show that the percent transmittance of the water to be disinfected at the New Providence WWTP is lower than most secondary effluent wastewaters which typically have a percent transmittance of around 65%. The lower percent transmittance characteristics at the New Providence facility necessitate increasing the UV dose given to the wastewater in order to achieve the same disinfecting results as an effluent with higher transmittance properties.

3.4.4 Temperature

Studies conducted by Severin determined that from a biological standpoint, the water temperature is not a major factor, if any in UV disinfection efficiency. However, the operating temperature of the UV lamp itself does have a major effect on the effective UV output intensity delivered by the lamp. Therefore, the lamp operating temperature will have an impact on the UV efficiency.⁶⁹

The optimum operating temperature for low pressure mercury vapor UV lamps is 40 degrees Celcius. The UV lamps effective output will be reduced by 1 to 3 percent for each degree higher or lower than the optimum lamp temperature. This effect is the result of the lamp's vapor pressure being changed due to either higher or lower temperatures. Reduced UV lamp output will decrease the disinfection efficiency.⁷⁰

Based on the studies conducted by Schiebe and Bassell, water temperature has only a very small effect on the UV lamps operating temperature. In the quartz system, there is an air gap that exists between the UV lamp and the quartz sleeve that protects the UV lamp from the flowing wastewater. This air gap insulates the UV lamp and prevents any dramatic changes in lamp operating temperatures caused by drastic changes in wastewater temperatures. At the Northwest Bergen facility, the lamp operating temperature was measured to be 43 degrees Celcius at an average wastewater temperature of 21.3 degrees Celcius. The lamp operating temperature decreased 3 degrees to 40 degree Celcius when the water temperature decreased to 10.5 degrees Celcius. Based on the results of this study, there was a small correlation between lamp operating temperature and water temperature.⁷¹

Based on the available information from the New Providence WWTP, it appeared that the optimum water temperature range for disinfection efficiency was between 15 - 21 degrees Celcius (see Figure 3-6). The UV system was designed to operate with water temperatures between 50 and 75 degrees Fahrenheit(10 to 24 degrees Celcius). Therefore, the optimum water temperature does fall within the middle of the design range.

The data above reflects water temperature and not the operating temperature of the UV lamp itself. No data was available on actual lamp operating temperatures. However, it can be assumed that lamp operating temperature will be proportional to water temperature for short contact times. Therefore, from the data available from operating records at the New Providence WWTP, it appeared that the optimum UV lamp operating temperature and optimum disinfection efficiency corresponded to a water temperature in the range of 15 - 21 degrees Celcius.

3.4.5 pH

Based on the plant operator's data available from just over two years of plant operation, no correlation was seen between pH and effluent fecal coliform levels (see Figure 3-7). The wastewater pH varied within a narrow range of values (6.0 - 7.9 S.U.) with an average pH of 7.0 S.U. This result is consistent with the findings of Mohan V. Thampi who concluded that UV disinfection is not pH dependent.⁷²

3.4.6 BOD, CBOD & NBOD

Based on analyzing the last two years of plant operating data there appeared to be no correlation between effluent fecal coliform count and effluent BOD (see Figure 3-8). The range of BOD values in Figure 3-8 varied from about 5.5 mg/l to 22 mg/l and the overall average of all BOD values was 13 mg/l (see Table 3-2). All effluent BOD values were below the permit limit of 24 mg/l and the design value of 30 mg/l used to design the UV system. For this reason, it would be expected that BOD in the range below 30 mg/l would have little to no effect on UV disinfection efficiency.

The CBOD concentrations shown on Figure 3-9 varied from 14 mg/l to about 42 mg/l; however, no correlation was observed between CBOD concentrations and fecal coliform survival rates. The average CBOD value was 25 mg/l. The NBOD concentrations shown on Figure 3-10 varied from about 6 mg/l to 75 mg/l; however, no correlation was observed between NBOD concentrations and fecal coliform survival rates. The average NBOD value was 27 mg/l.

In contrast to the findings reached by analyzing the data collected from the New Providence WWTP, a study performed at the Hyrum, Utah WWTP (see Section 6.1) that uses UV for wastewater effluent disinfection concluded that BOD and total organic carbon levels do produce a significant correlation to fecal coliform survival and UV absorbance values.⁷³ However, no correlations between BOD, CBOD or NBOD to fecal coliform survival rates were mentioned in the literature reviewed of other studies on factors that affect UV disinfection performance.

3.4.7 Dissolved Oxygen

Dissolved oxygen data was plotted against effluent fecal coliform counts and shown graphically in Figure 3-11. As can be seen from the graph, dissolved oxygen values ranged from approximately 6 mg/l to 13 mg/l; however, there was no effect on the disinfection efficiency of the UV system. This finding is consistent with other studies investigating parameters that affect UV system performance.

4.0 VERONA TERTIARY WASTEWATER TREATMENT PLANT - CASE STUDY

4.1 Facility Description and Brief History

The Township of Verona Wastewater Treatment Plant is located in Verona, Essex County, New Jersey on approximately 13 acres off of Commerce Court (see Figure 4-1a). The facility serves approximately 6140 customers in the Township of Verona and portions of West Orange, Essex Fells, Caldwell and Cedar Grove.⁷⁴

The Verona WWTP was originally constructed in 1919 and consisted of settling tanks, contact beds, a sewage pump station and sand filters. Major upgrades of the Verona facility took place in 1935, 1954, 1963 and most recently in 1991. The 1991 upgrade of the Verona WWTP had a construction cost of approximately \$16.8 million and upgraded the facility to provide a tertiary level of treatment. The new tertiary facility consists of inlet facilities, primary clarifiers, trickling filters, secondary clarifiers, oxidation ditches, final settling tanks, microscreens, ultraviolet disinfection, post aeration and sludge handling facilities. Figure 4-1b shows the flow diagram of the upgraded Verona Tertiary WWTP.⁷⁵

More stringent requirements by NJDEPE required the Township of Verona to upgrade the treatment plant to provide a higher level of treatment before discharging the treated effluent into the Peckman River. NJDEPE required nitrification facilities to reduce the ammonia levels discharged from 30 mg/l to less than 2 mg/l. The treatment plant before the 1991 upgrade had no

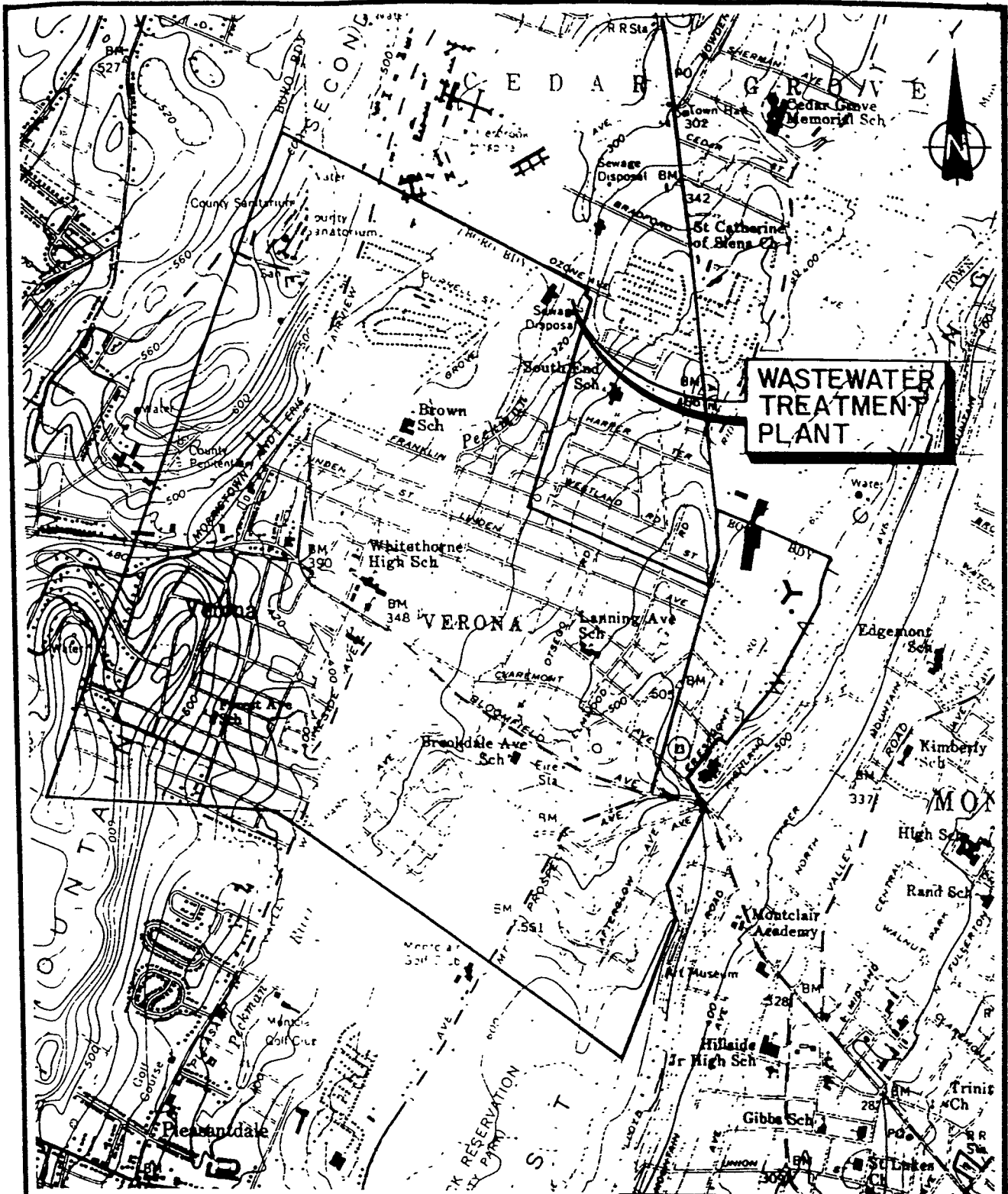

**WASTEWATER
TREATMENT
PLANT**



BASE MAP: U.S.G.S. CALDWELL AND ORANGE QUADRANGLES

FIGURE 4-1a.
TOWNSHIP OF VERONA
ESSEX COUNTY, NEW JERSEY
WASTEWATER TREATMENT
LOCATION PLAN

Courtesy of:
Elson T. Killam Associates, Inc.
Environmental and Hydraulic Engineers
27 Blocher Street Millburn, New Jersey 07041

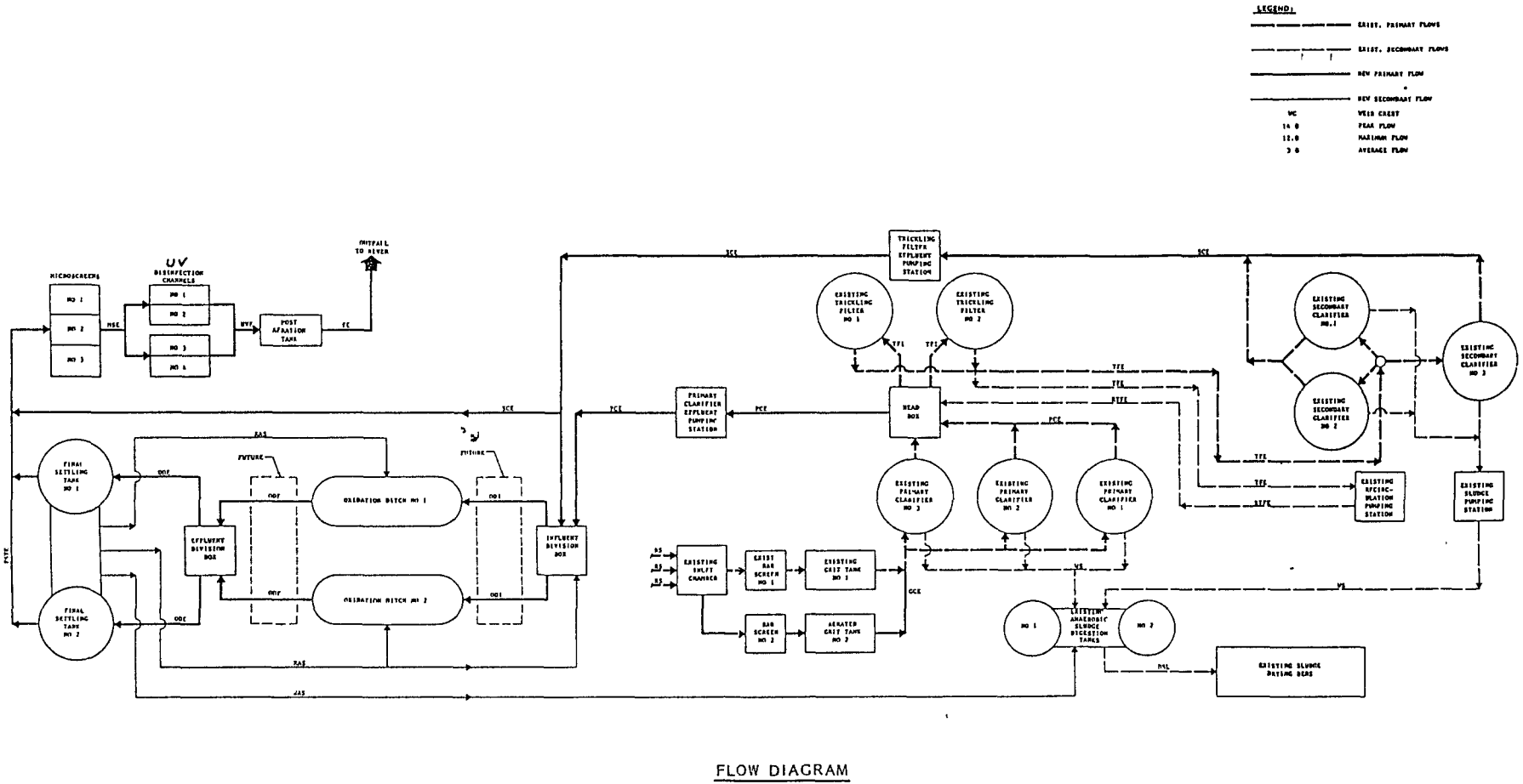

FLOW DIAGRAM

Figure 4-1b.
 TOWNSHIP OF VERONA
 ESSEX COUNTY, NEW JERSEY
 WASTEWATER TREATMENT PLANT ADDITIONS
 FLOW DIAGRAM

Courtesy of: **Elson T Killam Associates, Inc.**
 Environmental and Hydraulic Engineers
 27 Shuster Street, Mahwah, New Jersey 07641



nitrification facilities. In addition, the levels of chlorine residual discharged to the Peckman River had to be reduced. These requirements by the NJDEPE initiated the upgrade of the Verona WWTP.⁷⁶

The use of chlorination/dechlorination, ozonation and ultraviolet irradiation were all analyzed as possible disinfection alternatives to meet the requirements set forth in the new NJPDES Permit. After analyzing each disinfection alternative, it was decided that ultraviolet irradiation would provide the most satisfactory method of disinfection.⁷⁷

4.2 Design Criteria

The UV system at the Verona WWTP was designed based on the parameters listed and described in Table 4-1. The characteristics of the wastewater coming into the UV reactor was expected to be of a fairly good quality, since the facility was designed to provide a tertiary level of treatment. For example, the 30-day maximum design value for both suspended solids and for BOD was only 8 mg/l. The level of disinfection that the UV system must achieve, as well as the UV reactor performance and reactor hydraulic characteristics that the system must satisfy are also included in Table 4-1.

Excerpts from the NJPDES Permit for the Verona WWTP that show the effluent discharge limits that the facility must comply with are included in Appendix D of this thesis.

TABLE 4-1
UV SYSTEM DESIGN PARAMETERS⁷⁸

1. UV SYSTEM INFLUENT CONDITIONS:

a. Total Suspended Solids

| | |
|------------------------|---------|
| maximum 30-day average | 8 mg/l |
| maximum 7-day average | 12 mg/l |
| maximum day | 20 mg/l |

b. BOD

| | |
|-----------------|---------|
| Monthly Average | 8 mg/l |
| Weekly Average | 12 mg/l |

c. Fecal Coliform Density (Geometric Mean)

| | |
|------------------------|---------------------------|
| Annual Average | 2×10^5 FC/100 ml |
| Maximum 30-day Average | 3×10^5 FC/100 ml |
| Maximum 7-day Average | 5×10^5 FC/100 ml |
| Maximum Day | 8×10^5 FC/100 ml |

d. UV Absorbance Coefficient at 253.7 nm

| | |
|------------------------|---|
| Annual Average | 0.356 cm^{-1} (70% Transmittance) |
| Maximum 30-day Average | 0.430 cm^{-1} (65% Transmittance) |
| Maximum 7-day Average | 0.510 cm^{-1} (55% Transmittance) |

e. Flow Rate

| | |
|------------------------|----------|
| Annual Average | 3.0 MGD |
| Maximum 30-day Average | 5.0 MGD |
| Maximum 7-day Average | 7.0 MGD |
| Maximum Daily Flow | 10.0 MGD |
| Peak Flow (4 Hour) | 14.0 MGD |

f. Ammonia Nitrogen (NH₃-N)

| | |
|-------------------------|--------|
| Maximum Monthly Average | 2 mg/l |
| Maximum Weekly Average | 3 mg/l |

g. Ultimate Nitrogenous BOD

| | |
|-------------------------|---------|
| Maximum Monthly Average | 10 mg/l |
| Maximum Weekly Average | 15 mg/l |

h. Dissolved Oxygen

| | |
|-------------------------|--------|
| Minimum Monthly Average | 6 mg/l |
|-------------------------|--------|

2. EFFLUENT CONDITIONS:

a. Effluent Fecal Coliform Limits

| | |
|------------------------|----------------------------|
| Maximum 30-day Average | 200 Fecal Coliforms/100 ml |
| Maximum 7-day Average | 400 Fecal Coliforms/100 ml |
| Maximum Day | 800 Fecal Coliforms/100 ml |

3. ULTRAVIOLET REACTOR PERFORMANCE CHARACTERISTICS:

- a. Dose after one (1) year = 24,000 uwatt. sec/cm²
- b. Arc Length Per Bank = 3132 inches
- c. Retention Time = 6.6 seconds

4. ULTRAVIOLET REACTOR CHARACTERISTICS:

The equipment manufacturer shall furnish a set of Residence Time Distribution (RTD) curves for a number of flow conditions. The RTD curves for the following indices must be submitted and meet the following conditions:

- a. $t_f/T > 0.5$
- b. $t_{90}/t_{10} < 2.0$
- c. $t_p/T > 0.9$
- d. $t_{50}/O = 0.9$ to 1.1
- e. $E < 500 \text{ cm}^2/\text{sec}$
- f. $d = 0.02$ to 0.05

Where:

- t_f = time at which the tracer first appears
- T = theoretical mean retention time (V_v/Q)
- t_{90} = time at which ninety (90) percent of tracer has passed through the reactor
- t_{10} = time at which ten (10) percent of tracer has passed through the reactor
- t_p = time at which the peak concentration of the tracer appears
- t_{50} = time at which fifty (50) percent of tracer has passed through the reactor
- O = the meantime (centroid) of the curve
- E = dispersion coefficient ($\text{length}^2/\text{sec}$)
- d = dispersion number
- V_v = liquid volume in the UV reactor or UV bank
- Q = total flow

4.3 Description of UV System

The UV system installed at the Verona WWTP is the Trojan System UV 2000 as manufactured by Trojan Technologies, Incorporated. The system consists of ultraviolet lamps mounted on rack assemblies that are placed side-by-side in the concrete UV channels. The UV lamps are submerged in the open channel in which the wastewater flows through by gravity. The lamps are oriented parallel to the flow of wastewater in order to provide the optimum degree of disinfection. Figures 4-1c through 4-1e show the Trojan UV system installed at the Verona WWTP. The UV radiation is provided by low pressure mercury vapor lamps that emit light having a wavelength of 253.7 nm that is lethal to microorganisms. The UV lamps are surrounded by a quartz sleeve and have water tight electrical connections. Quartz sleeves in the Trojan System are protected by a special "Trojan 5" compound that significantly reduces any coating from building up on the quartz sleeve that could reduce the UV intensity.⁷⁹

The Trojan UV system at the Verona WWTP consists of two (2) UV chambers and each chamber is composed of two (2) channels. There are two (2) banks of UV lamps within each UV channel for a total of eight (8) UV banks. Each bank consists of thirteen (13) UV modules that hold the individual UV lamps (total of 104 UV modules). Each UV module holds eight (8) UV lamps which are 64 inches long.⁸⁰

Each UV lamp is held in UV modules and is completely submerged in the wastewater to be disinfected. Each module holds eight (8) lamps which are mounted horizontally parallel to the flow spaced several inches apart in the vertical plane. Each UV module has a power cord that connects the UV module

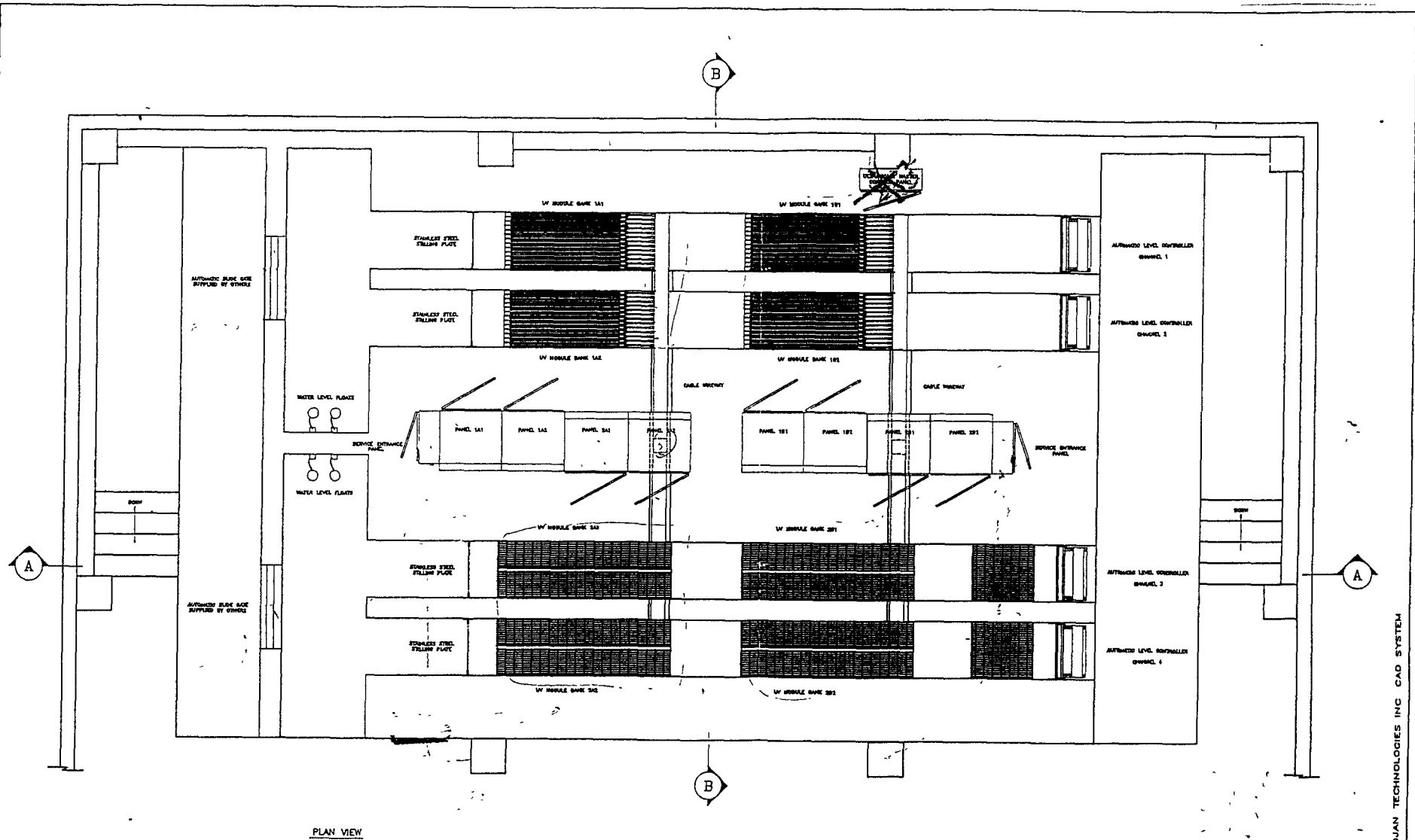

PLAN VIEW

FIGURE 4-1c. ULTRAVIOLET DISINFECTION FACILITIES AT THE VERONA WWTP (COURTESY OF TROJAN TECHNOLOGIES, INC., LONDON, ONTARIO).

| NO. | REVISION | DATE |
|-----|----------------------------------|----------|
| 1 | REWORK PANELS 141, 142, 151, 152 | APR 1989 |



Trojan

| | |
|---------------------------|-------------------|
| VERONA N.J. | SCALE 1/2"=1' |
| UV DISINFECTION EQUIPMENT | DRAWN BY KJW |
| | DATE APRIL 1989 |
| | DWG. NO. 2270001D |
| | DISC. NO. 8D13 |

TROJAN TECHNOLOGIES INC CAD SYSTEM

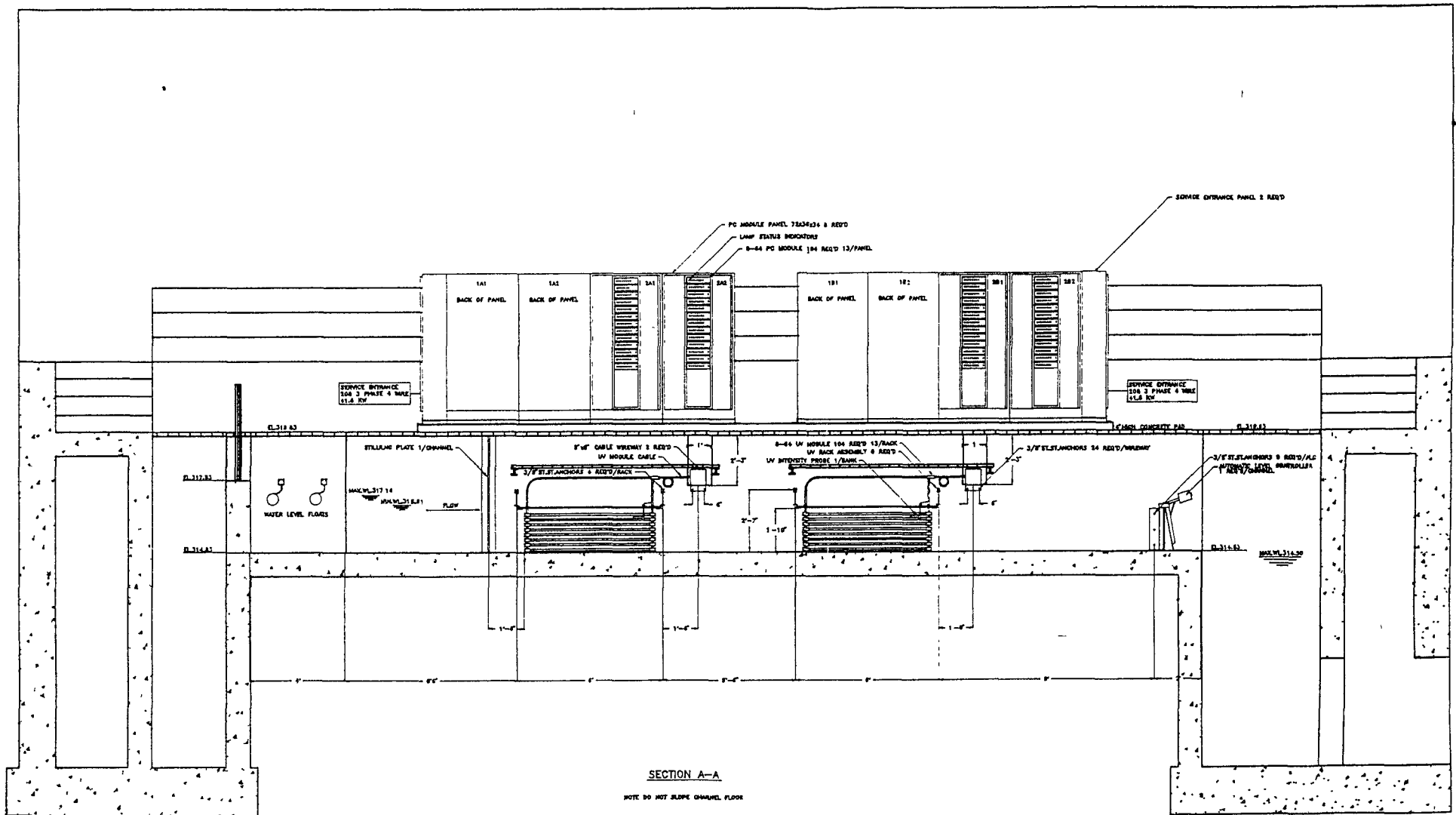

SECTION A-A

NOTE: DO NOT SLOPE CHANNEL FLOOR

FIGURE 4-1d. SECTIONAL VIEW OF ULTRAVIOLET DISINFECTION FACILITIES AT THE VERONA WWTP (COURTESY OF TROJAN TECHNOLOGIES, INC., LONDON, ONTARIO).

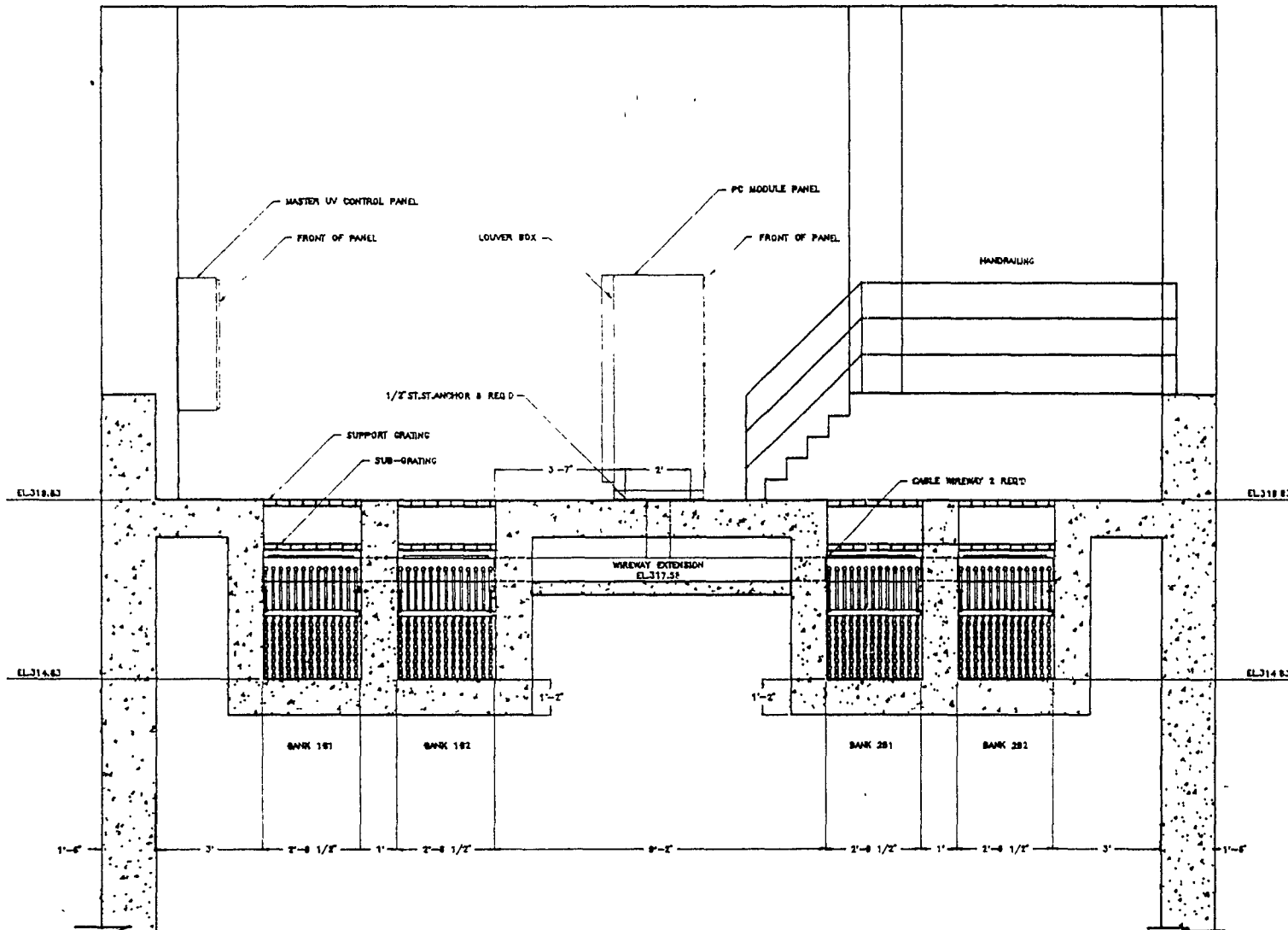

SECTION B-B

NOTE—CHANNEL WIDTH OF 2'-8 1/2" MUST BE KEPT WITHIN A TOLERANCE OF 1/4"

NOTE—SEE PACKAGE FOR WIREWAY DETAILS—NO SEALING IS REQUIRED BETWEEN CHANNEL WALLS
WIREWAY IS FABRICATED IN A SINGLE SECTION ALSO CONCRETE SLOT MUST BE FORMED BELOW
PANELS AS SHOWN.

FIGURE 4-1e. SECTIONAL VIEW OF ULTRA-VIOLET DISINFECTION FACILITIES AT THE VERONA WWTB (COURTESY TROJAN TECHNOLOGIES, INC.).

to the power control module located in the control panel. The purpose of the UV power control module (there is one for each UV module) is to provide electrical power to the UV lamps and to monitor their operation. Signals to turn the UV lamps on and off are received from the Power Control Module. Both the UV modules and UV power control modules may be removed separately to allow for maintenance and/or replacement as needed. Their removal will not affect the operation of the remaining UV modules. Each individual UV lamp has an light emitting diode within the Control Panel to tell the plant operator whether there are any lamps not operating properly or if a lamp has burnt out. Lamp ballasts are kept at proper operating temperatures by cooling fans that are located near the ballasts within the control cabinet.⁸¹

An Automatic Level Controller is used to keep the wastewater at the proper height within the UV channel. It is important to keep the depth of water at the proper level so that all UV lights are always submerged and that there is never too much water above the upper most UV lamp.⁸²

4.3.1 System Control

The UV disinfection system at the Verona WWTP was designed and has been operating in automatic mode where the number of UV banks in operation is varied according to the flow. A flow signal is transmitted from the effluent flow meter to the UV control panel which in turn sends signals to turn on and off the appropriate UV lamps and opens and closes the motorized slide gates to the UV channels as required.⁸³

The operator must initially select the lead and lag chambers (each chamber consists of 2 channels) by using selector switches and place the system into automatic mode. The motorized slide gate located at the head of the lead UV chamber will be signalled to open and allow flow to pass through both channels of the lead UV chamber. Flows up to 7.0 MGD will be treated in the lead UV chamber. As flows exceed 7.0 MGD, the motorized slide gate for the lag UV chamber will automatically open and allow flow to pass through both channels of the lag chamber - the lead chamber and channels will also remain in operation. Within each channel there are two (2) UV banks. With flows up to 3.0 MGD only one (1) UV bank will be in operation in each channel of the lead chamber. The motorized slide gate operators will signal which of the banks will be designated as the lead bank (either the two upstream banks of the lead UV chamber or the two downstream banks of the lead chamber) with the other being designated as the lag bank. When flows exceed 3.0 MGD, the lag banks will be energized; therefore, all four (4) banks will be energized within the lead chamber.⁸⁴

When flows exceed 7.0 MGD, the slide gate of the lag chamber shall open and energize all of the banks within the lag chamber. At this time all UV banks in both chambers will be in operation. Upon decreasing flow, the slide gates will be closed and UV banks deenergized as programmed.⁸⁵

4.3.2 UV Intensity Meter

The UV system at the Verona WWTP has an intensity meter installed within each of the UV chambers to monitor the disinfecting power of the system. The intensity meter allows the operator to quickly obtain a good indication of the

UV dose being received by the microorganism and therefore how the overall system is performing. A drop in the UV intensity meter reading could be caused by either reduced UV light output or by a change in effluent quality. Either one of these conditions could result in higher effluent fecal coliform counts and thus is a good indicator of the UV disinfecting power. A drop in the intensity meter reading will alert the operator of changing conditions within the UV disinfection system and that corrective actions may be necessary.⁸⁶

4.3.3 Cleaning UV Lamps

The UV lamps must be cleaned periodically to prevent the accumulation of debris and fouling of the quartz tube. At the Verona WWTP they use a cleaning tank with an air scrubber. The cleaning tank is just big enough to hold one UV module which consists of 8 individual UV lamps. The tank is filled with a 5% Phosphoric Acid cleaning solution and the air scrubber is turned on for approximately 30 seconds. The UV module is then removed from the cleaning tank and put on the drip rack where the lamps are manually wiped clean. After this the lamps are ready to be put back into service. At the Verona facility they just recently started cleaning the UV lamps on a regular basis - at one month intervals. In the past, they only cleaned the lamps when they noticed a loss in UV disinfection performance.⁸⁷

4.4 Analysis of UV System Performance

The UV system manufactured by Trojan Technologies, Inc. was placed into service at the Verona WWTP in early January of 1991. Approximately 10 months of operational data (January through October 1991) was compiled in evaluating the

performance of the disinfection facilities. This data is summarized in Table 4-2 and is located in Appendix E. Twelve (12) graphs were developed plotting the effluent fecal coliform concentration or effluent enterococci concentration against typical wastewater characteristics such as flow, BOD, and suspended solids. These graphs are contained in Appendix F.

As mentioned previously, past studies of UV disinfection systems have discovered that the following parameters are the most important and useful in monitoring the efficiency and performance of an UV system:

- Fecal coliform entering the UV reactor
- Fecal coliform exiting the UV reactor
- TSS entering the UV reactor
- Absorbance or percent transmittance of the wastewater
- Flow rate at time of sampling
- Number of UV lamps in operation at time of sampling.⁸⁸

Any factor that affects UV intensity or retention time of the wastewater within the UV chamber will affect performance of the UV system.

Unfortunately, the Verona WWTP does not routinely monitor the majority of the above parameters, since they are not required to report such data by their NJPDES Permit. Of the above listed parameters, only the effluent fecal coliform concentrations and total suspended solids concentration are routinely measured. Fecal coliform concentrations entering the UV reactor were measured for approximately a one month period. No absorbance or percent transmittance data of the wastewater was available. The number of UV lamps in operation is not recorded by plant personnel, since the system is usually operated in automatic mode where the number of lamps in operation is automatically adjusted according to plant flow.

The following sub-sections discuss the correlations or lack of discovered through analysis of the UV system at the Verona tertiary facility.

4.4.1 Flow

The total daily influent plant flow is routinely measured at the Verona WWTP and these values were used in comparisons with the disinfection efficiency of the UV lamps. Plant personnel do not take instantaneous flow readings within the UV reactor at the same time as the fecal coliform grab sample is obtained - such flow readings would give the most accurate correlation between flow and UV disinfection efficiency. However, since such measurements are not required by the facility's discharge permit, these measurements are not taken by plant personnel.

The average daily influent plant flow over the ten (10) month case study period was 2.48 MGD with a minimum daily flow of 1.2 MGD and a maximum of 5.8 MGD (see Table 4-2). These flows are below the design flow rates as listed in Table 4-1. The annual average design flow and maximum 30-day average design flow were 3.0 MGD and 5.0 MGD, respectively. The UV system is normally operated in automatic mode in which more UV banks are put into service as the flow increases. Unfortunately, there is no data available on the number of banks in service at any particular time. For this reason, it was not possible to come up with an amount of flow per UV bank in operation which would give a more accurate analysis of how the amount of flow through the UV chambers affect the disinfection efficiency.

Based on the available data, there was no distinct correlation between total plant flow and the effluent fecal coliform concentration as is shown in Figure 4-1. Even at a flow of 5.8 MGD, the effluent fecal coliform concentration was only 6 fecal coliforms per a 100 ml sample. However, from the graph it can be seen that all the highest effluent fecal coliform concentrations occurred in a range of total plant flows between 1.5 MGD to 2.0 MGD. Based on the automatic operation of the UV system, additional UV lamps should be activated when flows exceed 3.0 MGD. If a high concentration of high fecal coliform values had been seen at flows between 2.0 MGD and 3.0 MGD, one could make a case that the disinfection efficiency decreased at a time when the flow per UV bank in operation was at a maximum value and at a point where additional flow would have automatically put additional UV banks into operation, thus reducing the flow per UV bank and hence causing the UV disinfection efficiency to increase. However, since the increase in fecal coliform concentration occurred at flows well below 3.0 MGD, I believe that the observed increase in fecal coliform at flows between 1.5 MGD and 2.0 MGD was just a coincidence and not related to the flow.

Figure 4-10, graphically displays the effluent enterococci concentrations plotted against the total plant flow. The number of data points was limited, but as with the fecal coliform and flow graph, the highest enterococci levels occurred at plant flows between 1.5 MGD and 2.0 MGD. These high values correspond closely with the high fecal coliform values and respective flows observed in Figure 4-1. For the reasons stated in the previous paragraph, I believe that there was no correlation between plant flow and disinfection efficiency based on the data collected for effluent enterococci concentrations.

Since the measured flows were well below the flows for which the UV system was designed for, one would expect little to no correlation between flow and UV disinfection efficiency. Based on studies by Qualls and others relating flow to disinfection efficiency, when the UV dosage is significantly reduced due to a decrease in contact time (i.e. exposure of microorganisms to the UV irradiation is decreased) the microorganism count will increase as the flow increases resulting in a lower disinfection efficiency of the UV system.⁸⁹

4.4.2 Suspended Solids

The UV system was designed based on the following total suspended solids concentrations: 1) maximum 30-day average of 8 mg/l; 2) maximum 7-day average of 12 mg/l; and 3) maximum day of 20 mg/l. The average effluent suspended solids concentration was only 3.6 mg/l and the maximum day was only 11 mg/l, both values are below the design values. The effluent fecal coliform count was plotted against the effluent suspended solids in Figure 4-2. Based on Figure 4-2, there was no correlation observed between suspended solids and UV disinfection efficiency. It was not surprising that no correlation was observed, since the range of suspended solids was so small (< 1 mg/l to 11 mg/l) and since the Verona WWTP has microscreens just prior to disinfection within the UV chambers. The microscreens aid in removing the larger suspended particulates from the wastewater stream prior to disinfection.

Studies by Qualls and his colleagues concluded that UV disinfection efficiency improved when effluent samples had been filtered prior to being disinfected. The tertiary filters remove the larger suspended particulates that shield the microorganisms from the lethal UV radiation.⁹⁰

Based on studies performed by Qualls, Johnson, Oliver, Cosgrove and others, high suspended solids and in particular large suspended particulates will decrease UV disinfection efficiency.⁹¹ Section 3.4.2 has an in depth discussion on the effect of suspended solids on UV reactor performance.

4.4.3 Temperature

The average effluent water temperature based on the ten (10) month study period was 15 degrees Celcius with a minimum temperature of 7 degrees Celcius and a maximum of 25 degrees Celcius. Figure 4-3 graphically shows the relationship between effluent water temperature and effluent fecal coliform count. Four (4) of the five (5) highest values seen in Figure 4-3 occurred at temperatures around 24 degrees Celcius and occurred in approximately a 30 day period. Based on conversations with Tim Newton, lab operator at the Verona WWTP, the UV lamps were not as clean as they should have been during this time period - from mid-July to mid-August 1991. The highest water temperatures occurred during this same time frame and correspond to the high values seen in Figure 4-3. As discussed in section 3.4.3, studies by Schiebe and Bassell concluded that water temperatures have only a small effect on UV disinfection efficiency.⁹² Therefore, based on the above, it can be concluded that water temperature had no affect on UV disinfection efficiency.

4.4.4 pH

The effluent pH varied from 6.0 S.U. to 8.7 S.U. with an average of 7.2 S.U. No correlation was observed between pH and effluent fecal coliform counts (see Figure 4-4). This result is consistent with the findings of M. V. Thampi.⁹³

4.4.5 BOD, CBOD & NBOD

The UV system was designed to disinfect wastewater having an average monthly BOD concentration of 8 mg/l and average monthly NBOD of 10 mg/l. The average BOD concentration, based on ten (10) months of plant operational data, was 2.8 mg/l with a maximum of 7.0 mg/l. The average effluent CBOD and NBOD were 3.8 mg/l and 2.8 mg/l, respectively (see Table 4-2). No correlation was observed between either BOD, CBOD or NBOD and UV disinfection performance (see Figures 4-5, 4-6, and 4-7). The BOD, NBOD and CBOD levels measured at the Verona WWTP were so low that one would not expect them to have any effect on the disinfection efficiency of the UV lamps.

4.4.6 Dissolved Oxygen

The Verona WWTP was designed to produce an effluent with a dissolved oxygen concentration of at least 6.0 mg/l. The average dissolved oxygen concentration was 8.2 mg/l and the range was from 6.0 mg/l to 12.0 mg/l. There was no correlation observed between dissolved oxygen levels and effluent fecal coliform counts (see Figure 4-8).

4.4.7 Alkalinity

Effluent alkalinity measurements varied from 6 mg/l to 216 mg/l. The average alkalinity concentration was 87 mg/l. In Figure 4-9, the effluent fecal coliform concentration was plotted against the effluent alkalinity. No correlation was observed between alkalinity and UV disinfection performance.

This result is consistent with findings from other studies that investigated wastewater characteristics that affect UV disinfection performance.⁹⁴

5.0 COMPARISON BETWEEN SECONDARY WWTP AND TERTIARY WWTP UV PERFORMANCE

5.1 Summary of UV Performance at the New Providence Secondary WWTP

The New Providence WWTP provides a secondary level of treatment of the influent wastewater. The New Providence WWTP has been using UV light for disinfection since July 1989. The Fischer & Porter UV disinfection system installed at the New Providence facility has been providing a fairly satisfactory level of disinfection of the treated effluent. From the time that the UV system was placed on-line up until the end of July 1991, there were approximately 156 effluent fecal coliform measurements taken. Of these 156 samples, 14 values exceeded 400 fecal coliforms per 100 ml sample which is the maximum weekly average allowed by their NJPDES Permit and 27 samples exceeded 200 fecal coliforms per 100 ml sample which is the maximum monthly average allowed by their NJPDES Permit. The average effluent fecal coliform concentration was 1,140 fecal coliforms/100 ml sample; however, this average is greatly distorted by several extremely high values including one sample of 114,000 fecal coliforms/100 ml sample.

The disinfection efficiency at the New Providence WWTP was found to be very dependent on the plant flow - the vast majority of high fecal coliform counts occurred at the same time as the higher levels of plant flow. For instance, the highest fecal coliform measurement of 114,000 counts per 100 ml sample occurred when the instantaneous flow through the UV reactor was 2.120 MGD which was much higher than the average plant effluent flow which was only 0.60 MGD.

5.2 Summary of UV Performance at the Verona Tertiary WWTP

A tertiary level of treatment is provided by the Verona WWTP. Microscreens were recently installed as part of the project to upgrade the Verona facility from a secondary plant to a tertiary plant. A UV disinfection system manufactured by Trojan Technologies, Inc. has been in operation providing disinfection of the treated effluent since early January 1991. The Trojan UV system has consistently been providing a very high level of disinfection. During the ten (10) month period that the system has been in service, approximately 119 fecal coliform samples have been taken and out of these samples only 4 samples exceeded 400 fecal coliforms/100 ml (NJPDES Permit maximum 7-day average) and only 5 samples exceeded 200 fecal coliforms/100 ml (NJPDES Permit maximum monthly average). The average effluent fecal coliform concentration during the ten (10) months of available UV operational data was 42 counts/100 ml. The Verona WWTP laboratory operator has been very pleased with the overall operation of the Trojan UV disinfection system.

5.3 Physical Description of UV Systems at both WWTP's

The Verona tertiary facility has more consistently provided a higher level of disinfection than the New Providence secondary treatment facility. Both UV disinfection systems are very similar in basic design, although the Verona system was manufactured by Trojan Technologies and Fischer & Porter manufactured the New Providence WWTP UV system. Both UV systems use low vapor mercury ultraviolet lamps that emit light radiation having a wavelength of 253.7 nm to provide disinfection. The UV lamps are surrounded in quartz sleeves and are held in place by rack assemblies. The rack assemblies in both

systems are submerged in the wastewater that is to be disinfected and placed parallel to the flow. Both systems were designed for automatic operation based on flow; however, the New Providence plant is usually operated in the manual mode. Some of the possible contributing factors accounting for the difference in UV disinfection performance observed between the Verona tertiary facility and the New Providence secondary WWTP will be explored in the following paragraphs.

5.4 Suspended Solids

The average total suspended solids concentrations for both treatment plants were fairly low, 12 mg/l for the New Providence WWTP and 3.6 mg/l for the Verona facility. The difference in suspended solids concentrations was probably one of the contributing factors accounting for the better disinfection efficiency observed at the Verona tertiary facility. Higher suspended solids concentrations increases the tendency for the suspended particulate matter to shield the microorganism from the UV radiation and thus reducing the UV disinfection efficiency.

Not only may the total suspended solids concentration be a contributing factor, but the actual size of the suspended particulate matter may be an even more significant factor in explaining the difference in UV disinfection performance observed. The Verona WWTP has microscreens just prior to the UV chambers that remove the larger suspended particulates from the wastewater flow to be treated. However, the New Providence plant is a secondary facility and therefore does not have any type of tertiary treatment process to remove the larger suspended particulate matter. Based on this, it can be concluded that

the New Providence facility would have larger suspended particulates and clumps in the effluent flow than the Verona facility. I believe that the suspected difference in the size of suspended particulates between the New Providence and Verona facilities account for a major portion of the difference in UV disinfection performance observed between the two treatment plants. Studies by Oliver, Cosgrove, Qualls and Johnson concluded that the size of suspended particulates have a very large effect on UV disinfection efficiency.⁹⁵

5.5 Transmittance

There were only a very limited number of percent transmittance measurements of the effluent wastewater from the New Providence WWTP available. However, the average percent transmittance of the wastewater was only 55 percent which is lower than the typical wastewater final effluent which is usually around 65 percent. There was no percent transmittance data available for the Verona WWTP final effluent, but since it is a tertiary facility the percent transmittance would probably be at least 65 percent. The difference in percent transmittance of the wastewater between the two facilities could be another reason for the observed difference in UV disinfection performance.

5.6 Flow

The average flow measured at the New Providence WWTP was 0.60 MGD, while the design average dry weather flow was 0.3 MGD to 0.4 MGD through each of the three UV channels. The design storm peak flow was 2.0 MGD through each UV channel. Typically the New Providence facility utilizes only one or two of the three UV channels, only under conditions of very high flows are all three

channels in use. Usually the plant operator will place both UV banks in operation of all channels that are in use. Assuming that two UV channels are in use and the average flow of 0.60 MGD is flowing through the system, this would mean that 0.3 MGD would be going through each UV channel which is the dry weather design flow. Based on this line of reasoning, the UV system has routinely been operating at the average dry weather design flow and at many times exceeding the dry weather design flow. From looking at Table 3-2, it can be seen that often only one UV channel was in service. The majority of high effluent fecal coliform values occurred when the flows exceeded the average dry weather design flow (see Figures 3-1 through 3-4). The Fischer & Porter UV system was designed to handle the peak flow rate of 2.0 MGD and therefore should be able to provide the necessary degree of disinfection at this level of flow, rather than at the much lower average dry weather design flows.

The Verona WWTP was usually operated in automatic mode based on plant flow measurements. Flows up to 3.0 MGD were treated with two banks of UV lamps and when flows exceeded 3.0 MGD, four banks of lamps were put into operation. The measured average flow was 2.48 MGD; therefore, in most cases only 2 banks of UV lamps were on-line. The annual average design flow was 3.0 MGD with a design four hour peak flow of 14.0 MGD. The Verona UV disinfection system seemed to have no problem handling the amount of flow being received. No correlation was observed between the plant flow and disinfection efficiency.

The capacity and ability of the two case study treatment plants to handle additional flow or flows higher than are usually received appears to be another factor explaining the difference in observed UV disinfection performance. Higher flows at the Verona facility did not affect UV disinfection

efficiency. However, higher flows at the New Providence WWTP had an adverse effect on the ability of the UV system to satisfactorily disinfect the wastewater on a consistent basis.

5.7 Degree of Disinfection using Chlorine as Compared to UV Radiation

5.7.1 New Providence WWTP

Prior to switching to UV radiation disinfection in July 1989, chlorine was used at the New Providence WWTP to disinfect the treated effluent before being discharged into the Passaic River. Table 5-1 summarizes the level of disinfection achieved during 1987 and 1988 when chlorine was used as the disinfecting agent. Table 5-1 shows that a high degree of disinfection was consistently achieved.

The average of the monthly averages was only 29 fecal coliforms per 100 ml sample, while the effluent fecal coliform concentration when UV was used as the disinfecting agent was 1,140 fecal coliforms per 100 ml sample. The average value for UV disinfection was greatly distorted by several extremely high values. The range of effluent fecal coliform concentrations for UV disinfection was from less than 1 count/100 ml to 114,000 counts/100 ml. The effluent fecal coliform range when chlorine disinfection was used during 1987 and 1988 was a much smaller range - the range for chlorine disinfection was from less than 1 count/100 ml to 525 counts/100 ml.

Fourteen (14) effluent fecal coliform samples out of approximately 156 samples taken when UV was used for disinfection exceeded 400 counts/100 ml and

TABLE 5-1. NEW PROVIDENCE WWTP EFFLUENT FECAL COLIFORM CONCENTRATIONS USING CHLORINE AS THE DISINFECTING AGENT.

| DATE | MONTHLY AVERAGE FECAL COLIFORM (#/100 ml) | HIGH FECAL COLIFORM RESULT DURING MONTH (#/100 ml) | COMMENTS |
|-----------|---|--|----------------------------------|
| Jan. '87 | 73 | 180 | |
| Feb. '87 | 17 | | |
| March '87 | 8 | | |
| April '87 | 11 | | |
| May '87 | 17 | | |
| June '87 | 10 | | |
| July '87 | 67 | 132 | |
| Aug. '87 | 50 | 189 | |
| Sept. '87 | 23 | 90 | |
| Oct. '87 | 4 | | |
| Nov. '87 | 26 | 110 | |
| Dec. '87 | 25 | 74 | |
| Jan. '88 | 34 | 124 | |
| Feb. '88 | 120 | 525 | High Result over 400 F.C./100 ml |
| March '88 | 9 | 23 | |
| April '88 | 0.5 | 1 | |
| May '88 | 7 | 30 | |
| June '88 | 2 | | |
| July '88 | 1 | | |
| Aug. '88 | 70 | 280 | High Result over 200 F.C./100 ml |
| Sept. '88 | 4 | | |
| Oct. '88 | 4 | | |
| Nov. '88 | 113 | 410 | High Result over 400 F.C./100 ml |
| Dec. '87 | 1 | | |
| MINIMUM | 0.5 | --- | |
| AVERAGE | 29 | --- | |
| MAXIMUM | 120 | 525 | |

NOTE: A minimum of four fecal coliform samples were analyzed each month, except for December 1987 (3 samples during month).

twenty-seven (27) samples exceeded 200 counts/100 ml. In comparison, out of approximately 96 effluent fecal coliform samples taken when chlorine was used for disinfection, only two (2) values exceeded 400 counts/100 ml and three (3) exceeded 200 counts/100 ml.

Based on the data collected from the New Providence WWTP, a higher degree of disinfection was achieved on a consistent basis when chlorine was used as the disinfecting agent as compared to when UV radiation was used. Although both methods of disinfection usually provided an adequate degree of disinfection, the UV disinfection system was subject to a much higher degree of variability due mainly to changing plant flows.

5.7.2 Verona WWTP

Chlorine was the disinfecting agent used at the Verona WWTP to disinfect the treated effluent prior to installation of their UV system in early 1991. Table 5-2 summarizes the effluent fecal coliform results during 1989 and 1990 (samples taken weekly) when chlorine was used to disinfect the wastewater prior to discharge to the Peckman River. The average of the monthly averages was only 6.5 fecal coliforms per 100 ml sample and the highest single sample was only 100 counts/100 ml sample. Based on this data, it can be seen that a very high degree of disinfection was consistently achieved at the Verona facility when chlorine was used as the method of disinfection.

In comparison, the Verona facility has also been experiencing an excellent level of disinfection with the newly installed UV disinfection system. During the 10 months of data available with the UV system on line, approximately 120

TABLE 5-2. VERONA WWTP EFFLUENT FECAL COLIFORM CONCENTRATIONS
USING CHLORINE AS THE DISINFECTING AGENT.

| DATE | MONTHLY AVERAGE FECAL COLIFORM (#/100 ml) | HIGH FECAL COLIFORM RESULT DURING MONTH (#/100 ml) |
|-----------|---|--|
| Jan. '89 | 5.3 | 34.4 |
| Feb. '89 | 4.0 | 18.0 |
| March '89 | 2.0 | 18.0 |
| April '89 | 2.3 | 6.0 |
| May '89 | 2.0 | 12.0 |
| June '89 | 7.0 | 25.0 |
| July '89 | 11.6 | 19.0 |
| Aug. '89 | 11.0 | 35.0 |
| Sept. '89 | 5.5 | 13.0 |
| Oct. '89 | 5.5 | 8.0 |
| Nov. '89 | 16.1 | 33.0 |
| Dec. '89 | 3.0 | 12.5 |
| Jan. '90 | 12.0 | 31.0 |
| Feb. '90 | 6.2 | 14.0 |
| March '90 | 5.3 | 11.0 |
| April '90 | 4.2 | 9.0 |
| May '90 | 2.0 | 7.0 |
| June '90 | 8.0 | 14.0 |
| July '90 | 2.1 | 4.0 |
| Aug. '90 | 1.3 | 2.0 |
| Sept. '90 | 1.0 | 3.0 |
| Oct. '90 | 1.5 | 4.0 |
| Nov. '90 | 14.0 | 31.0 |
| Dec. '90 | 24.0 | 100.0 |
| MINIMUM | 1.0 | 2.0 |
| AVERAGE | 6.5 | 19.3 |
| MAXIMUM | 24.0 | 100.0 |

NOTE: Fecal Coliform samples were taken on a weekly basis.

fecal coliform samples were analyzed and only 5 samples exceeded 200 fecal coliforms per 100 ml sample. The average fecal coliform concentration was only 42 counts per 100 ml, well below the maximum monthly average of 200 counts/100 ml that the Verona WWTP must meet to satisfy their NJPDES Permit.

A high level of disinfection was consistently achieved at the Verona WWTP when chlorine was used as the disinfecting agent as well as when UV radiation was used to disinfect the treated wastewater. The average fecal coliform concentration for chlorine disinfection was slightly less than for UV disinfection, but both values were low (6.5 counts/100 ml for chlorine as compared to 42 counts/100 ml for UV).

6.0 CONCLUSIONS

6.1 Summary of Findings from Case Study Facilities

Based on analyzing the operation of two full scale wastewater treatment plants that use UV radiation for disinfection of their treated effluent, UV disinfection systems appear to be a viable alternative to other methods of disinfection. The UV system at the Verona tertiary facility has been consistently providing a high degree of disinfection. The UV system at the New Providence secondary facility has in general provided a satisfactory degree of disinfection; however, it was subject to poor disinfection efficiencies upon high plant flows.

An inverse correlation was observed at the New Providence WWTP between plant flow and disinfection efficiency. Increased plant flow shortened the contact time between the UV radiation and microorganisms, consequently reducing the UV dose experienced by the microorganism, resulting in a lower level of disinfection. Available data suggested that the optimum water temperature to promote a high degree of disinfection was from 15 to 21 degrees Celcius. No other correlations were observed at the New Providence facility. The range of typical wastewater parameters such as suspended solids and BOD were quite small, making it more difficult to observe any type of correlation between these parameters and UV disinfection efficiency.

No correlations between UV disinfection efficiency and various wastewater parameters were observed at the Verona tertiary facility. The range of suspended solids, BOD and other parameters was extremely small, consequently

making it less likely to observe any type of correlation to factors that affect UV efficiency. The plant flow at the Verona did vary somewhat; however, the UV system was being operated in automatic mode where additional UV banks were energized upon increasing flow, hence keeping the average dose received by the microorganisms fairly uniform. The flow paced UV system appeared to be working very well, since the level of disinfection did not decrease when the plant flows increased.

Several hypotheses were raised as to explain the higher level of disinfection achieved at the Verona facility as compared to the New Providence facility and they include the following:

- Lower suspended solids at Verona WWTP
- Size of suspended particulates are smaller at the Verona facility since the microscreens remove the larger particulates prior to disinfection
- Wastewater at the New Providence facility has a lower percent transmittance
- Tertiary facility as compared to Secondary facility
- Insufficient contact time at New Providence facility during high flows.

More research, controlled tests and analyses must be performed to thoroughly investigate the above hypotheses, before any conclusions could be drawn as to whether the above reasons do adequately explain the difference in UV disinfection efficiencies observed between the two facilities.

In summary, UV disinfection systems can be successfully used to disinfect treated wastewater effluents from both secondary and tertiary facilities and does represent a very good alternative to disinfection with chlorine. UV systems seem best suited for tertiary facilities and treatment plants that produce a high quality effluent. UV disinfections systems may also be

successfully implemented at secondary facilities, but one must be aware that a higher UV dose may be required to achieve the same degree of disinfection as that at a tertiary facility.

6.2 Hyrum, Utah Municipal Wastewater Treatment Plant

The operation and effectiveness of the ultraviolet (UV) radiation system used to disinfect the effluent wastewater at the Hyrum, Utah Municipal Wastewater Treatment Plant was analyzed by a nine month field and laboratory study. Some of the conclusions reached by this study in regards to factors affecting the performance of UV disinfection included:

- a significant inverse correlation between suspended solids and UV disinfection efficiency was observed;
- a significant correlation between UV absorbance and fecal coliform survival (turbidity measurements should be a good parameter to relate to disinfection efficiency and UV absorbance);
- BOD and total organic carbon were concluded to be significantly correlated to fecal coliform survival and UV absorbance.⁹⁶

6.3 Future of UV Disinfection of Wastewater

The future of UV light as a means of efficiently disinfecting wastewater does look very promising. One of the driving forces to use UV light to disinfect wastewater is that this would eliminate the discharge of chlorine and its harmful byproducts into receiving waterways which is the result when chlorination is the method of disinfection. UV disinfection has many advantages over disinfection with chlorine or some of the other commonly used alternative methods of disinfection. Some of the advantages include:

- No toxic chemicals are produced or discharged that may be harmful to man or the aquatic biosystem
- The need for transporting, storing or handling dangerous chemicals is eliminated
- UV does not introduce any taste or odors into either the water or atmosphere
- Many pathogens, including viruses and spore-forming bacteria are eliminated more effectively
- Low maintenance requirements
- Very simple day-to-day operation of the UV disinfection equipment.⁹⁷

In recent years, many pilot plant studies and full scale wastewater treatment plants have shown that UV is a very viable alternative to disinfection with chlorine. These studies in general have also shown that UV is cost competitive with chlorination and provides effective disinfection. However, a better knowledge of the design criteria for UV systems is required for the potential of UV to be fully realized.⁹⁸

In addition, there have been some mechanical problems associated with UV systems that must be resolved for UV systems to reach their full potential. Some of the mechanical problems that require improvements include cleaning mechanisms for lamps, better control over operating temperature of lamps, and control of energy loss through the production of ozone in the air gap between the quartz sleeve and the UV tube.⁹⁹ A study conducted in 1984 of 52 wastewater treatment plants that utilize UV for disinfection reported that most of the problems encountered resulted from mechanical, electrical, and hydraulic problems, and not with the actual UV process itself. The hydraulic problems resulted in improper geometry in the UV tank design - these problems can be eliminated by following the guidelines for chamber design to achieve the desired hydraulic characteristics as described previously in this report.

Some of the electrical problems encountered included insufficient ventilation of the ballasts and other heat generating equipment which resulted in failure and in some cases electrical fires.¹⁰⁰

Some areas of UV disinfection of wastewater that requires additional knowledge and a more thorough understanding include how photoreactivation and the shielding and particulate protection impact effluent quality at point of discharge and also within the receiving waterway.¹⁰¹

One variation of UV disinfection that has shown some promise is the use of ozone in conjunction with UV. The use of either ozone-UV or UV-ozone in series has shown to be more economical than either ozone or UV by itself. Further research must be done on the feasibility of this alternative, but it does show some promise.¹⁰²

Over the past few years, the NJDEPE has imposed much stricter regulations on allowable levels of chlorine residual that publicly owned treatment works may discharge into the receiving waterways in an effort to improve the overall quality of the state's waterways. The stricter chlorine residual requirements, have forced many treatment plants to install dechlorination facilities or to look to alternative methods of disinfection. UV disinfection has been the choice of disinfection for some of these facilities. The trend of increased awareness of type and quantity of chemicals including chlorine discharged into our country's waterways will likely continue to increase throughout the entire country in the future resulting in tougher standards - this trend will also help increase the use of UV for disinfection. I believe that the use of UV

radiation for the disinfection of wastewater effluents will continue to grow in the future as UV develops a more extensive operating history, concerns for water quality of receiving waterways increase, and as design engineers become more confident in the ability of UV to successfully disinfect wastewater.

APPENDIX A

NEW PROVIDENCE WWTP -
NJPDES PERMIT

PERMIT NUMBER NJ0021636

Permittee
NEW PROVIDENCE BOROUGH OF
PARK PLACE
NEW PROVIDENCE, NJ 07974

Co-Permittee

Property Owner
BOROUGH OF NEW PROVIDENCE
360 ELKWOOD AVENUE
NEW PROVIDENCE, NJ 07974

Location of Activity
NEW PROVIDENCE BOROUGH OF WTP
PARK PLACE
NEW PROVIDENCE, NJ 07974

=====
Current Authorization
Covered By This Approval
And Previous Authorization

| | <u>Issuance Date</u> | <u>Effective Date</u> | <u>Expiration Date</u> |
|--------------------------|--------------------------|---------------------------|----------------------------|
| A :Sanitary SW Discharge | 5/11/90 | 7/01/90 | 4/30/92 |

=====

By Authority of:
Eric J. Evenson
Acting Director
Division of Water Resources

DEP AUTHORIZATION
John F. Fields
Acting Assistant Director
Wastewater Facilities Management Element

EFFLUENT LIMITATIONS AND MONITORING REQUIREMENTS
FOR NJPDES/DSW PERMITS FOR MUNICIPAL (SANITARY) DISCHARGES

1. EFFLUENT LIMITATIONS

- A. Final Effluent Limitations. The permittee shall not discharge pollutants from any location(s) which are not specifically authorized by a valid NJPDES Permit.

In accordance with the permit conditions contained in Part IV-A during the period beginning November 4, 1992 and lasting until the expiration date of this permit, discharges from outfall 001* shall be limited by the permittee as specified below:

- (1) Discharge so as to not violate the Surface Water Quality Standards for the Passaic River, classified as FW2-Nontrout waters.
- (2) A substantially complete removal of settleable solids shall be achieved.
- (3) Discharge in compliance with Tables III-A-1 and 2.
- (4) Except as specifically authorized in this permit, the permittee shall not discharge floating solids or visible foam.
- (5) The effluent values for pH shall remain within the limits of 6.0 to 9.0 standard units.
- (6) The 30-day average quantity of effluent discharged from the wastewater treatment facility shall not exceed 1.5 million gallons per day (MGD).

* The location and description of outfall 001 is as follows:

Latitude: 40° 42' 50" North
Longitude: 74° 24' 15" West

B. Interim Effluent Limitations. In accordance with the permit conditions contained in Part IV-A during the period beginning on the effective date of this permit and lasting until November 3, 1992, discharges from outfall 001* shall be limited by the permittee as specified below:

- (1) Same as permit condition 1.A(2).
- (2) Discharge in compliance with Tables III-A-3 and 4.
- (3) Same as permit condition 1.A(4).
- (4) Same as permit condition 1.A(5).
- (5) The 30-day average quantity of effluent discharged from the wastewater treatment facility shall not exceed 1.5 MGD.

TABLE III-A-1

FINAL EFFLUENT LIMITATIONS

(Final Limits Will Be Effective Beginning on November 4, 1992)

| EFFLUENT CHARACTERISTICS | (1) Maximum Load Allocations | | (1) Maximum Concentrations | | (1) Minimum Percent Removal Limitations | |
|--|---|--|---|--|--|----------------------------|
| | Average Monthly Discharge Limitation (kg/day) | Average Weekly Discharge Limitation (kg/day) | Average Monthly Discharge Limitation (mg/L) | Average Weekly Discharge Limitation (mg/L) | Average Monthly | Any Four Hour Period |
| 5-Day 20 Deg. C Biochemical Oxygen Demand | 91 | 136 | 16 | 24 | 85 | |
| Ultimate Carbonaceous Biochemical Oxygen Demand | 136 | 204 | 24 | 36 | | |
| Suspended Solids | 91 | 136 | 16 | 24 | 85 | |
| Ultimate Nitrogenous Biochemical Oxygen Demand (7) | 114 | 170 | 20 | 30 | | |
| Fecal Coliform Organisms Number per 100 mL (3) | | | 200 | 400 (2) | | |
| Enterococci Organisms Number per 100 mL (3) | | | 33 | 61 (5) | | |
| Dissolved Oxygen | | | 4 (4) | 6 (6) | | |
| Oil and Grease | | | 10 | 15 (5) | | |

- (1) Whichever is most stringent.
(2) Levels shall not exceed limit in more than 10 percent of the samples taken during a period of 30 consecutive days.
(3) Geometric Mean.
(4) Minimum at any time.
(5) Maximum for any single sample.
(6) Minimum weekly average.
(7) Shall be met from May 1st to October 31st of every year;
NBODu concentration shall be calculated as follows:

$$NBODu = 5.0 \times \text{Ammonia Nitrogen.}$$

TABLE III-A-2

FINAL EFFLUENT LIMITATIONS

TOXICITY

(Final Limits Will Be Effective Beginning on November 4, 1992)

| EFFLUENT CHARACTERISTICS | (1) Maximum Load Allocations | | (1) Maximum Concentrations | | |
|---|---|--|---|--|---|
| | Average Monthly Discharge Limitation (kg/day) | Average Weekly Discharge Limitation (kg/day) | Average Monthly Discharge Limitation (mg/L) | Average Weekly Discharge Limitation (mg/L) | Daily Maximum Discharge Limitation (mg/L) |
| <u>WHOLE EFFLUENT TESTING</u> | | | | | |
| Chronic Biomonitoring, NOEL | | | (4) | | |
| <u>Pimephales promelas</u> | | | 40% | | |
| <u>Ceriodaphnia dubia</u> | | | 40% | | |
| <u>CHEMICAL SPECIFIC TOXICITY TESTING</u> | | | | | |
| Ammonia, Total as N (NH ₃ -N) | (3) | (3) | (3) | (3) | (3) |
| Chlorine Produced Oxidants (CPO) | | | | | 0.01 (2) |
| Cyanide | | | (3) | (3) | (3) |
| Phenols | | | (3) | (3) | (3) |
| <u>TOXIC ORGANICS</u> | | | | | |
| Volatiles | | | (3) | (3) | (3) |
| Acid Compounds | | | (3) | (3) | (3) |
| Base/Neutral Compounds | | | (3) | (3) | (3) |
| Pesticides | | | (3) | (3) | (3) |
| <u>TOXIC METALS</u> | | | | | |
| Antimony, Total | | | (3) | (3) | (3) |
| Arsenic, Total | | | (3) | (3) | (3) |
| Beryllium, Total | | | (3) | (3) | (3) |
| Cadmium, Total | | | (3) | (3) | (3) |
| Chromium, Total | | | (3) | (3) | (3) |
| Copper, Total | | | (3) | (3) | (3) |
| Lead, Total | | | (3) | (3) | (3) |
| Mercury, Total | | | (3) | (3) | (3) |
| Nickel, Total | | | (3) | (3) | (3) |
| Selenium, Total | | | (3) | (3) | (3) |
| Silver, Total | | | (3) | (3) | (3) |
| Thallium, Total | | | (3) | (3) | (3) |
| Zinc, Total | | | (3) | (3) | (3) |

(1) Whichever is most stringent.

(2) The calculated water quality based effluent limitations are 0.01 mg/L as a maximum 24 hour average, and 0.02 as a maximum at any time. However, the current detection limit using an approved testing method is 0.1 parts per million, or mg/L. Therefore, the permittee shall comply with the limit of 0.1 mg/L as a maximum at any time until such time as the level of detectability has changed and after due notice from the Department.

(3) To be determined.

(4) Minimum for any single and or test. Equivalent to 2.5 TU_c.

TABLE III-A-3

INTERIM EFFLUENT LIMITATIONS

(These Interim Limits Are Effective From The Effective Date Of Permit Modification Through November 3, 1992)

| EFFLUENT CHARACTERISTICS | (1) Maximum Load Allocations | | (1) Maximum Concentrations | | (1) Minimum Percent Removal Limitations | |
|--|---|--|---|--|--|----------------------------|
| | Average Monthly Discharge Limitation (kg/day) | Average Weekly Discharge Limitation (kg/day) | Average Monthly Discharge Limitation (mg/L) | Average Weekly Discharge Limitation (mg/L) | Average Monthly | Any Four Hour Period |
| 5-Day 20 Deg. C Biochemical Oxygen Demand | 91 | 136 | 16 | 24 | 85 | |
| Ultimate Carbonaceous Biochemical Oxygen Demand | 136 | 204 | 24 | 36 | | |
| Suspended Solids | 91 | 136 | 16 | 24 | 85 | |
| Ultimate Nitrogenous Biochemical Oxygen Demand (7) | 114 | 170 | 20 | 30 | | |
| Fecal Coliform Organisms Number per 100 mL (3) | | | 200 | 400 (2) | | |
| Enterococci Organisms Number per 100 mL (3) | | | 33 | 61 (5) | | |
| Dissolved Oxygen | | | 4 (4) | 6 (6) | | |
| Oil and Grease | | | 10 | 15 (5) | | |

- (1) Whichever is most stringent.
(2) Levels shall not exceed limit in more than 10 percent of the samples taken during a period of 30 consecutive days.
(3) Geometric Mean.
(4) Minimum at any time.
(5) Maximum for any single sample.
(6) Minimum weekly average.
(7) Shall be met from May 1st to October 31st of every year;
NBODu concentration shall be calculated as follows:

$$NBODu = 5.0 \times \text{Ammonia Nitrogen.}$$

TABLE III-A-4

INTERIM EFFLUENT LIMITATIONS
TOXICITY

(Interim Limits Will Be Effective From The Effective Date Of Permit Modification Through November 3, 1992)

| EFFLUENT CHARACTERISTICS | (1) Maximum Load Allocations | | (1) Maximum Concentrations | | |
|--|---|--|---|--|---|
| | Average Monthly Discharge Limitation (kg/day) | Average Weekly Discharge Limitation (kg/day) | Average Monthly Discharge Limitation (mg/L) | Average Weekly Discharge Limitation (mg/L) | Daily Maximum Discharge Limitation (mg/L) |
| WHOLE EFFLUENT TESTING | | | | | |
| Acute Biomonitoring, 96 hr LC50 Pimephales promelas | | | (3) 50 % | | |
| CHEMICAL SPECIFIC TOXICITY TESTING | | | | | |
| Ammonia, Total as N (NH3-N) (4) | 23 | 34 | 4 | 6 | |
| Chlorine Produced Oxidants (CPO) | | | | | 0.01 (2) |

(1) Whichever is most stringent.

(2) The calculated water quality based effluent limitations are 0.01 mg/L as a 24 hour average, and 0.02 mg/L as a maximum at any time. However, the current detection limit using an approved testing method is 0.1 parts per million, or mg/L. Therefore, the permittee shall comply with the limit of 0.1 mg/L as a maximum at any time until such time as the level of detectability has changed and after due notice from the Department.

(3) Minimum for any sample and or test. Equivalent to 2.0 TU .

(4) Shall be met from May 1st to October 31st of every year. ^a

2. Influent and Effluent Monitoring Requirements (1)

A. Beginning on the effective date of this permit, discharges shall be monitored as specified below:

| <u>Effluent Characteristic</u> | <u>Measurement Frequency</u> | <u>Sample Type</u> |
|---|------------------------------|---------------------|
| Total Flow, MGD | Continuous | ...Conutinous |
| BOD5, mg/L | 1/week | ...24 hr. composite |
| BOD5, kg/day | 1/week | ...Calculated |
| BOD5, percent removal | 1/week | ...Calculated |
| CBODu, mg/L | 1/week | ...24 hr. composite |
| CBODu, kg/day | 1/week | ...Calculated |
| Suspended Solids, mg/L | 1/week | ...24 hr. composite |
| Suspended Solids, kg/day | 1/week | ...Calculated |
| Suspended Solids, percent removal | 1/week | ...Calculated |
| Total Kjeldahl Nitrogen, mg/L (2) | 1/week | ...24 hr. composite |
| Total Kjeldahl Nitrogen, kg/day (2) | 1/week | ...Calculated |
| NBODu, mg/L | 1/week | ...Calculated (4) |
| NBODu, kg/day | 1/week | ...Calculated |
| Fecal Coliform, N per 100 mL (2) (3) | 1/week | ...Grab |
| Enterococci Organisms, N per 100 mL (2) (3) | 1/week | ...Grab |
| Dissolved Oxygen, mg/l (2) | 2/day | ...Grab |
| Oil and Grease, mg/l (2) | 1/month | ...Grab |
| Total Residual Chlorine, mg/L (2) | 2/day | ...Grab |
| Settleable Solids, mL/L | 2/day | ...Grab |
| pH | 2/day | ...Grab |
| Temperature, degree C | 2/day | ...Grab |

(1) Except where indicated influent and effluent measurement and testing is required.

(2) Only effluent testing required.

(3) Fecal Coliform and Enterococci calculation shall be reported in terms of geometric mean.

(4) NBOD_u concentration should be calculated as follows:

$$NBOD_u = 5.0 \times \text{Ammonia Nitrogen}$$

Effluent Toxicity Monitoring Requirements (1)

B. Beginning on the effective date of this permit, discharges shall be monitored for toxicity as specified below:

| <u>Minimum Monitoring Requirements</u> | | |
|--|---------------------------------|--------------------------------|
| <u>Effluent Characteristic...</u> | <u>Measurement Frequency...</u> | <u>Sample Type</u> |
| <u>Chemical Specific Toxicity Testing</u> | | |
| Chlorine Produced Oxidants, (CPO) mg/L..... | 2/Day | ...Grab |
| Ammonia Nitrogen, mg/L.... | Weekly | ...24 hr. composite |
| Cyanide, Total, ug/L..... | Weekly | ...Grab |
| Phenols, ug/L..... | Monthly | ...Grab |
| <u>Toxic Organics</u> | | |
| Acid Compounds, ug/L. EPA Method 625 (5)..... | Monthly | ...24 hr. composite |
| Base/Neutral Compounds, ug/L, EPA Method 625 (5). | Monthly | ...24 hr. composite |
| Pesticides, ug/L, EPA Method 625 (5)..... | Monthly | ...24 hr. composite |
| Volatiles, ug/L, EPA Method 624 (5)..... | Monthly | ...Grab |
| <u>Toxic Metals</u> | | |
| Antimony, Total, ug/L..... | Monthly | ...24 hr. composite |
| Arsenic, Total, ug/L..... | Weekly | ...24 hr. composite |
| Beryllium, Total, ug/L.... | Monthly | ...24 hr. composite |
| Cadmium, Total, ug/L..... | Weekly | ...24 hr. composite |
| Chromium, Total, ug/L.... | Monthly | ...24 hr. composite |
| Copper, Total, ug/L..... | Weekly | ...24 hr. composite |
| Lead, Total, ug/L..... | Weekly | ...24 hr. composite |
| Mercury, Total, ug/L..... | Weekly | ...24 hr. composite |
| Nickel, Total, ug/L..... | Monthly | ...24 hr. composite |
| Selenium, Total, ug/L.... | Monthly | ...24 hr. composite |
| Silver, Total, ug/L..... | Weekly | ...24 hr. composite |
| Thallium, Total, ug/L.... | Monthly | ...24 hr. composite |
| Zinc, Total, ug/L..... | Weekly | ...24 hr. composite |
| <u>Whole Effluent Toxicity Testing</u> | | |
| Acute Biomonitoring (96 hour LC 50), percent wastewater (3)..... | Annually | ..(Required until 11/04/92) |
| Chronic Biomonitoring (NOEL), percent wastewater (4)..... | Quarterly | ... |

(1) Except where indicated, only effluent measurement and testing is required. mg/L = milligrams/liter and ug/L = micrograms/liter. The loading in kg/day, shall be calculated and reported on DMR at the same frequency as the concentrations, for all "toxics" effluent characteristics except for acute and chronic biomonitoring. All chemical specific testing shall be conducted concurrently with the whole effluent testing requirements of this permit.

MODIFICATION

- (2) Influent and effluent testing required.
- (3) Bioassay testing using a properly conducted flow-through or renewal test representing effluent quality in accordance with N.J.A.C. 7:18-6 and Part IV-A of this permit shall be deemed acceptable.
(In addition to being summarized and reported on a discharge monitoring form, bioassay test results shall be reported on forms provided by the Certified Laboratory postmarked no later than the 25th day of the month following the completed reporting period. Copies of the biomonitoring report shall be submitted to the NJDEP and USEPA at the addresses indicated elsewhere in the permit, and to the Municipal Bioassay Program, Wastewater Facilities Management Element, Division of Water Resources, CN-029, Trenton, N.J., 08625.)
- (4) Bioassay testing using a properly conducted test in accordance with Part IV-A of this permit and "Interim Chronic Methodologies for Use in the NJPDES Permit Program, Version 1.0," February 1989 (copy attached), shall be deemed acceptable.
(In addition to being summarized and reported on a discharge monitoring form, bioassay test results shall be reported on forms provided by the Certified Laboratory postmarked no later than the 25th day of the month following the completed reporting period. Copies of the biomonitoring report shall be submitted to the NJDEP and USEPA at the addresses indicated elsewhere in the permit, and to the Municipal Bioassay Program, Wastewater Facilities Management Element, Division of Water Resources, CN-029, Trenton, N.J., 08625.)
- (5) Organic Priority Pollutants are to be quantified using appropriate GC/MS protocols.

C. Submission of Monitoring Reports

Monitoring results obtained during the previous month shall be summarized and reported on the appropriate form(s) specified by the Department. Monitoring reports shall be postmarked by the 25th day of the month following the completed reporting period and shall be due on the first day of the following month. The first report is due on EDP + 2 months.

- D. Other requirements pertaining to monitoring and reporting are contained in Part I, Section 11 and Part II-A, Section 3.

APPENDIX B

NEW PROVIDENCE WWTP -
DAILY OPERATOR'S LOG DATA

**TABLE 3-2. NEW PROVIDENCE WASTEWATER TREATMENT PLANT
DAILY OPERATOR'S LOG DATA**

| DATE | FLOW (MGD) | | | | | FECAL COLIFORM | | ENTEROCOCCI ORGANISMS | | UV DISINFECTION | | | | | | | PLANT INFLUENT | | | | | |
|----------|------------------|------------------|-----------------------|----------------------|---------------------|-------------------------|-------------------------|------------------------|------------------------|--------------------|----|----|----|----|----|------------------------|----------------|----------------|-------------------|--------------------|------------------|------------------|
| | TOTAL PLANT INF. | TOTAL PLANT EFF. | INSTANT. FLOW THRU UV | EFF FLOW PER UV BANK | INST. Q PER UV BANK | INFLUENT (Fecal/100 ml) | EFFLUENT (Fecal/100 ml) | INFLUENT (Ent./100 ml) | EFFLUENT (Ent./100 ml) | BANKS IN OPERATION | | | | | | TOTAL # OF BANKS OPER. | PH A.M. (S.U.) | PH P.M. (S.U.) | TEMP. A.M (deg C) | TEMP. P.M. (deg C) | SET. SOLIDS A.M. | SET. SOLIDS P.M. |
| | | | | | | | | | | 1A | 1B | 2A | 2B | 3A | 3B | | | | | | | |
| 07/03/89 | 1.40 | 0.51 | | | | | 6 | | | | | | | | | N/A | 7.31 | 7.66 | 22 | 22 | 10 | 11 |
| 07/04/89 | 1.32 | 0.65 | | | | | | | | | | | | | | N/A | 7.13 | 8.00 | 20 | 23 | 3 | 18 |
| 07/05/89 | 2.64 | 1.48 | | | | | | | | | | | | | | N/A | 7.30 | 7.07 | 22 | 23 | 12 | 8 |
| 07/06/89 | 1.96 | 0.76 | | | | | | | | | | | | | | N/A | 7.69 | 7.23 | 21 | 23 | 8 | 25 |
| 07/10/89 | 1.75 | 0.64 | | | | | 0 | | | | | | | | | N/A | 7.47 | 7.46 | 22 | 23 | 8 | 9 |
| 07/11/89 | 1.67 | 0.60 | | | | | | | | | | | | | | N/A | 7.55 | 7.49 | 23 | 22 | 9 | 6 |
| 07/12/89 | 1.63 | 0.63 | | | | | | | | | | | | | | N/A | 7.55 | 7.29 | 21 | 23 | 10 | 15 |
| 07/13/89 | 1.72 | 0.65 | | | | | | | | | | | | | | N/A | 7.33 | 7.32 | 22 | 22 | 7 | 14 |
| 07/17/89 | 1.67 | 0.70 | | | | | 13 | | | | | | | | | N/A | 7.38 | 7.61 | 21 | 23 | 13 | 10 |
| 07/18/89 | 1.72 | 0.56 | | | | | | | | | | | | | | N/A | 7.32 | 7.60 | 22 | 23 | 8 | 9 |
| 07/19/89 | 1.78 | 0.64 | | | | | | | | | | | | | | N/A | 7.12 | 7.66 | 21 | 24 | 10 | 14 |
| 07/20/89 | 1.70 | 0.57 | | | | | | | | | | | | | | N/A | 7.23 | 7.46 | 22 | 21 | 17 | 10 |
| 07/24/89 | 1.67 | 0.57 | | | | | 10 | | | | | | | | | N/A | 7.43 | 6.84 | 23 | 24 | 5 | 9 |
| 07/25/89 | 1.79 | 0.73 | | | | | | | | | | | | | | N/A | 7.56 | 7.53 | 22 | 24 | 10 | 10 |
| 07/26/89 | 1.70 | 0.64 | | | | | | | | | | | | | | N/A | 7.26 | 7.24 | 24 | 23 | 11 | 15 |
| 07/31/89 | 1.57 | 0.46 | 0.150 | | | 22,600 | 17 | | | | | | | | | 7.60 | 7.59 | 22 | 23 | 8 | 12 | |
| 08/02/89 | 1.60 | 0.93 | | | | | | | | | | | | | | 7.03 | 7.31 | 23 | 22 | 12 | 8 | |
| 08/07/89 | 1.53 | 0.47 | | | | | 30 | | | | | | | | | 6.61 | 7.23 | 24 | 24 | 13 | 11 | |
| 08/08/89 | 1.55 | 0.47 | | | | | | | | | | | | | | 7.38 | 7.65 | 21 | 24 | 10 | 7 | |
| 08/09/89 | 1.60 | 0.48 | 0.222 | | | 70,000 | 16 | | | | | | | | | 7.70 | 7.32 | 21 | 24 | 9 | 16 | |
| 08/10/89 | 1.56 | 0.43 | | | | | 24 | | | | | | | | | 7.28 | 7.33 | 20 | 23 | 11 | 12 | |
| 08/14/89 | 1.69 | 0.67 | | | | 47,000 | 60 | | | | | | | | | 7.33 | 7.12 | 23 | 25 | 11 | 9 | |
| 08/15/89 | 1.69 | 0.67 | | | | | 46 | | | | | | | | | 7.08 | 7.09 | 23 | 24 | 8 | 8 | |
| 08/16/89 | 1.80 | 0.55 | | | | | | | | | | | | | | 7.75 | 7.20 | 24 | 23 | 12 | 10 | |
| 08/17/89 | 1.63 | 0.40 | | | | | 83 | | | | | | | | | 6.68 | 7.23 | 24 | 24 | 10 | 8 | |
| 08/22/89 | 2.09 | 0.61 | | | | | 40 | | | | | | | | | 7.53 | 7.51 | 22 | 24 | 11 | 11 | |
| 08/24/89 | 1.74 | 0.45 | | | | | | | | | | | | | | 7.20 | 7.62 | 21 | 24 | 15 | 11 | |
| 08/29/89 | 2.04 | 0.74 | | | | | | | | | | | | | | 7.78 | 7.54 | 22 | 23 | 11 | 13 | |
| 08/30/89 | 2.02 | 0.67 | | | | | 199 | | | | | | | | | 7.66 | 7.61 | 23 | 24 | 11 | 13 | |
| 09/01/89 | 2.03 | 0.56 | | | | | | | | | | | | | | 7.54 | 7.63 | 21 | 24 | 9 | 18 | |
| 09/05/89 | 2.02 | 0.45 | | | | | | | | | | | | | | 7.68 | 7.50 | 20 | 23 | 11 | 12 | |
| 09/06/89 | 1.56 | 0.36 | | | | | 57 | | | | | | | | | 7.44 | 7.75 | 22 | 24 | 13 | 13 | |
| 09/07/89 | 1.47 | 0.29 | | | | | | | | | | | | | | 7.72 | 7.49 | 21 | 24 | 18 | 14 | |
| 09/11/89 | 1.46 | 0.28 | | | | | | | | | | | | | | 7.57 | 7.39 | 23 | 24 | 8 | 15 | |
| 09/12/89 | 1.40 | 0.29 | | | | | 41 | | | | | | | | | 7.44 | 7.44 | 24 | 24 | 13 | 10 | |
| 09/13/89 | 1.47 | 0.31 | | | | | | | | | | | | | | 7.66 | 7.28 | 22 | 24 | 14 | 21 | |
| 09/16/89 | 1.57 | 0.34 | | | | | 17 | | | | | | | | | 7.03 | 7.29 | 22 | 24 | 16 | 7 | |
| 09/20/89 | 4.22 | 2.96 | | | | | | | | | | | | | | 7.54 | 7.32 | 23 | 24 | 3 | 6 | |
| 09/25/89 | 2.33 | 1.66 | | | | | | | | | | | | | | 7.10 | 7.57 | 21 | 22 | 8 | 7 | |
| 09/26/89 | 2.82 | 1.15 | 2.120 | | | 114,000 | 37 | | | | | | | | | 6.84 | 7.12 | 21 | 22 | 4 | 6 | |
| 09/27/89 | 2.35 | 0.78 | | | | | | | | | | | | | | 7.25 | 7.27 | 20 | 22 | 14 | 6 | |
| 09/28/89 | 2.15 | 0.87 | | | | | | | | | | | | | | 6.92 | 7.63 | 19 | 22 | 8 | 7 | |
| 09/29/89 | 2.10 | 0.43 | | | | | 44 | | | | | | | | | 6.74 | 6.87 | 19 | 22 | 8 | 8 | |
| 10/02/89 | 3.06 | 1.37 | 1.195 | | | 3,500 | | | | | | | | | | 6.86 | 7.34 | 22 | 23 | 6 | 6 | |
| 10/03/89 | 2.51 | 0.88 | | | | | 282 | | | | | | | | | 6.71 | 7.44 | 21 | 22 | 7 | 10 | |
| 10/04/89 | 2.18 | 0.45 | | | | | 31 | | | | | | | | | 7.29 | 7.34 | 19 | 19 | 13 | 11 | |
| 10/05/89 | 1.99 | 0.39 | | | | | | | | | | | | | | 7.58 | 7.64 | 19 | 21 | 7 | 9 | |
| 10/07/89 | 1.77 | 0.35 | | | | | 311 | | | | | | | | | 7.45 | 7.33 | 19 | 20 | 4 | 5 | |

**TABLE 3-2. NEW PROVIDENCE WASTEWATER TREATMENT PLANT
DAILY OPERATOR'S LOG DATA**

| DATE | FLOW (MGD) | | | | | FECAL COLIFORM | | ENTEROCOCCI ORGANISMS | | UV DISINFECTION | | | | | | | PLANT INFLUENT | | | | | |
|----------|------------------|------------------|-----------------------|----------------------|---------------------|-------------------------|-------------------------|------------------------|------------------------|--------------------|----|----|----|----|----|------------------------|----------------|----------------|--------------------|--------------------|------------------|------------------|
| | TOTAL PLANT INF. | TOTAL PLANT EFF. | INSTANT. FLOW THRU UV | EFF FLOW PER UV BANK | INST. Q PER UV BANK | INFLUENT (Fecal/100 ml) | EFFLUENT (Fecal/100 ml) | INFLUENT (Ent./100 ml) | EFFLUENT (Ent./100 ml) | BANKS IN OPERATION | | | | | | TOTAL # OF BANKS OPER. | PH A.M. (S.U.) | PH P.M. (S.U.) | TEMP. A.M. (deg C) | TEMP. P.M. (deg C) | SET. SOLIDS A.M. | SET. SOLIDS P.M. |
| | | | | | | | | | | 1A | 1B | 2A | 2B | 3A | 3B | | | | | | | |
| 10/10/89 | 1.81 | 0.21 | 0.254 | | | | 17 | | | | | | | | | | 7.70 | 7.60 | 18 | 22 | 12 | 9 |
| 10/11/89 | 1.75 | 0.27 | | | | | | | | | | | | | | | 7.60 | 7.56 | 20 | 22 | 11 | 9 |
| 10/16/89 | 1.68 | 0.21 | 0.228 | | | | 57 | | | | | | | | | | 7.18 | 7.81 | 21 | 23 | 9 | 10 |
| 10/17/89 | 2.59 | 0.92 | 0.383 | | | | 73 | | | | | | | | | | 7.24 | 7.37 | 21 | 23 | 10 | 13 |
| 10/18/89 | 2.38 | 1.52 | | | | | 333 | | | | | | | | | | 7.53 | 7.53 | 19 | 20 | 7 | 10 |
| 10/19/89 | 3.31 | 1.80 | 2.103 | | | | | | | | | | | | | | 7.35 | 7.35 | 20 | 19 | 11 | 8 |
| 10/20/89 | 5.26 | 3.26 | | | | | 111 | | | | | | | | | | 7.10 | 6.77 | 20 | 19 | 2 | 3 |
| 10/24/89 | 2.40 | 0.84 | 1.103 | | | | 222 | | | | | | | | | | 7.27 | 7.52 | 19 | 21 | 8 | 9 |
| 10/25/89 | 2.26 | 0.72 | 1.113 | | | | 127 | | | | | | | | | | 7.44 | 7.43 | 19 | 20 | 8 | 11 |
| 10/26/89 | 2.16 | 0.67 | | | | | | | | | | | | | | | 7.56 | 7.48 | 20 | 22 | 8 | 13 |
| 10/27/89 | 1.99 | 0.44 | | | | | 168 | | | | | | | | | | 7.52 | 7.58 | 20 | 22 | 10 | 12 |
| 10/30/89 | 1.85 | 0.20 | 0.311 | | | | 78 | | | | | | | | | | 7.96 | 7.68 | 21 | 22 | 18 | 15 |
| 10/31/89 | 2.47 | 1.09 | 0.393 | | | | 70 | | | | | | | | | | 7.43 | 7.63 | 21 | 21 | 9 | 8 |
| 11/01/89 | 2.48 | 0.73 | 1.115 | | | | 178 | | | | | | | | | | 7.56 | 7.41 | 20 | 22 | 12 | 9 |
| 11/02/89 | 2.17 | 0.56 | | | | | | | | | | | | | | | 7.61 | 7.50 | 20 | 20 | 10 | 35 |
| 11/06/89 | 1.92 | 0.41 | 0.892 | | | | 187 | | | | | | | | | | 7.75 | 7.62 | 19 | 21 | 13 | 9 |
| 11/07/89 | 1.84 | 0.33 | | | | | | | | | | | | | | | 7.28 | 7.59 | 19 | 20 | 9 | 9 |
| 11/08/89 | 2.10 | 0.89 | | | | | | | | | | | | | | | 7.50 | 7.69 | 19 | 21 | 11 | 11 |
| 11/13/89 | 2.21 | 0.59 | | | | | 30 | | | | | | | | | | 7.21 | 7.46 | 19 | 20 | 14 | 9 |
| 11/15/89 | 2.01 | 0.46 | | | | | | | | | | | | | | | 7.29 | 7.58 | 20 | 22 | 6 | 9 |
| 11/16/89 | 2.01 | 0.48 | | | | | | | | | | | | | | | 7.71 | 6.71 | 21 | 20 | 7 | 10 |
| 11/20/89 | 1.91 | 0.38 | 0.616 | | | | 198 | | | | | | | | | | 7.66 | 7.33 | 18 | 19 | 12 | 11 |
| 11/21/89 | 1.95 | 0.30 | | | | | | | | | | | | | | | 7.66 | 7.81 | 19 | 19 | 7 | 15 |
| 11/27/89 | 2.09 | 0.33 | 0.245 | | | | 56 | | | | | | | | | | 7.69 | 7.75 | 18 | 18 | 12 | 7 |
| 11/28/89 | 2.22 | 0.68 | | | | | | | | | | | | | | | 7.00 | 7.61 | 18 | 20 | 9 | 11 |
| 11/29/89 | 2.01 | 0.48 | | | | | | | | | | | | | | | 7.12 | 7.24 | 19 | 19 | 7 | 9 |
| 11/30/89 | 1.94 | 0.35 | | | | | | | | | | | | | | | 7.19 | 7.53 | 18 | 19 | 9 | 8 |
| 12/04/89 | 1.77 | 0.30 | 0.181 | 0.075 | 0.045 | | 16 | | | 1 | 1 | 1 | 1 | 0 | 0 | 4 | 7.43 | 7.70 | 15 | 17 | 11 | 11 |
| 12/05/89 | 1.85 | 0.23 | | 0.058 | | | | | | 1 | 1 | 1 | 1 | 0 | 0 | 4 | 7.17 | 7.13 | 17 | 18 | 10 | 14 |
| 12/06/89 | 1.85 | 0.34 | | 0.170 | | | | | | 1 | 1 | 0 | 0 | 0 | 0 | 2 | 7.53 | 7.69 | 18 | 19 | 7 | 13 |
| 12/11/89 | 1.75 | 0.24 | 0.139 | 0.120 | 0.070 | | 16 | | | 1 | 1 | 0 | 0 | 0 | 0 | 2 | 7.69 | 7.52 | 18 | 18 | 15 | 15 |
| 12/12/89 | 1.96 | 0.25 | | 0.125 | | | | | | 1 | 1 | 0 | 0 | 0 | 0 | 2 | 7.25 | 7.59 | 18 | 18 | 8 | 14 |
| 12/13/89 | 2.00 | 0.44 | | 0.220 | | | | | | 1 | 1 | 0 | 0 | 0 | 0 | 2 | 7.38 | 7.77 | 16 | 18 | 15 | 12 |
| 12/18/89 | 1.77 | 0.27 | 0.265 | 0.135 | 0.133 | | 11 | | | 1 | 1 | 0 | 0 | 0 | 0 | 2 | 7.24 | 7.74 | 16 | 17 | 20 | 15 |
| 12/20/89 | 1.74 | 0.25 | | 0.125 | | | | | | 1 | 1 | 0 | 0 | 0 | 0 | 2 | 7.92 | 7.46 | 16 | 17 | 8 | 9 |
| 12/21/89 | 1.66 | 0.29 | | 0.145 | | | | | | 1 | 1 | 0 | 0 | 0 | 0 | 2 | 7.21 | 7.35 | 16 | 17 | 7 | 12 |
| 12/26/89 | 1.65 | 0.23 | | 0.115 | | | 6 | | | 1 | 1 | 0 | 0 | 0 | 0 | 2 | 7.82 | 8.26 | 13 | 14 | 7 | 12 |
| 12/27/89 | 1.50 | 0.32 | | 0.160 | | | | | | 1 | 1 | 0 | 0 | 0 | 0 | 2 | 7.70 | 7.50 | 13 | 15 | 15 | 12 |
| 01/02/90 | 1.87 | 0.30 | 0.175 | 0.150 | 0.088 | | 50 | | | 1 | 1 | 0 | 0 | 0 | 0 | 2 | 7.53 | 7.22 | 17 | 17 | 8 | 9 |
| 01/03/90 | 1.85 | 0.36 | | 0.180 | | | | | | 0 | 0 | 1 | 1 | 0 | 0 | 2 | 7.28 | 7.34 | 15 | 18 | 10 | 13 |
| 01/04/90 | 1.69 | 0.32 | | 0.160 | | | | | | 0 | 0 | 1 | 1 | 0 | 0 | 2 | 7.12 | 7.20 | 16 | 15 | 11 | 11 |
| 01/07/90 | 1.88 | 0.15 | | 0.075 | | | | | | 0 | 0 | 1 | 1 | 0 | 0 | 2 | 7.28 | 7.30 | 12 | 12 | 3 | 6 |
| 01/08/90 | 1.78 | 0.35 | 0.340 | 0.175 | 0.170 | | 10 | | | 0 | 0 | 1 | 1 | 0 | 0 | 2 | 7.34 | 7.34 | 16 | 17 | 7 | 18 |
| 01/09/90 | 1.94 | 0.52 | | 0.260 | | | | | | 0 | 0 | 1 | 1 | 0 | 0 | 2 | 7.08 | 7.25 | 15 | 18 | 8 | 20 |
| 01/10/90 | 2.21 | 0.77 | | 0.385 | | | | | | 0 | 0 | 1 | 1 | 0 | 0 | 2 | 7.55 | 7.29 | 15 | 15 | 11 | 25 |
| 01/11/90 | 2.12 | 1.04 | | 0.520 | | | | | | 0 | 0 | 1 | 1 | 0 | 0 | 2 | 7.05 | 7.43 | 14 | 16 | 10 | 12 |
| 01/15/90 | 2.18 | 0.54 | 0.281 | 0.270 | 0.141 | | 9 | | | 0 | 0 | 1 | 1 | 0 | 0 | 2 | 7.18 | 7.45 | 15 | 18 | 11 | 13 |
| 01/16/90 | 1.99 | 0.61 | | 0.305 | | | 92 | | | 1 | 1 | 0 | 0 | 0 | 0 | 2 | 8.06 | 7.36 | 15 | 17 | 14 | 12 |

TABLE 3-2. NEW PROVIDENCE WASTEWATER TREATMENT PLANT
DAILY OPERATOR'S LOG DATA

| DATE | FLOW (MGD) | | | | | FECAL COLIFORM | | ENTEROCOCCI ORGANISMS | | UV DISINFECTION | | | | | | | PLANT INFLUENT | | | | | |
|----------|------------------|------------------|-----------------------|----------------------|---------------------|-------------------------|-------------------------|------------------------|------------------------|--------------------|----|----|----|----|----|------------------------|----------------|----------------|--------------------|--------------------|------------------|------------------|
| | TOTAL PLANT INF. | TOTAL PLANT EFF. | INSTANT. FLOW THRU UV | EFF FLOW PER UV BANK | INST. Q PER UV BANK | INFLUENT (Fecal/100 ml) | EFFLUENT (Fecal/100 ml) | INFLUENT (Ent./100 ml) | EFFLUENT (Ent./100 ml) | BANKS IN OPERATION | | | | | | TOTAL # OF BANKS OPER. | PH A.M. (S.U.) | PH P.M. (S.U.) | TEMP. A.M. (deg C) | TEMP. P.M. (deg C) | SET. SOLIDS A.M. | SET. SOLIDS P.M. |
| | | | | | | | | | | 1A | 1B | 2A | 2B | 3A | 3B | | | | | | | |
| 01/17/90 | 2.15 | 0.59 | | 0.295 | | | | | | 1 | 1 | 0 | 0 | 0 | 0 | 2 | 7.38 | 7.24 | 17 | 16 | 13 | 11 |
| 01/18/90 | 2.32 | 0.74 | | 0.370 | | | | | | 1 | 1 | 0 | 0 | 0 | 0 | 2 | 7.14 | 7.32 | 18 | 16 | 14 | 12 |
| 01/22/90 | 2.30 | 0.70 | 1.242 | 0.350 | 0.621 | | 195 | | | 1 | 1 | 0 | 0 | 0 | 0 | 2 | 7.38 | 7.41 | 15 | 17 | 11 | 11 |
| 01/23/90 | 2.06 | 0.58 | | 0.290 | | | | | | 1 | 1 | 0 | 0 | 0 | 0 | 2 | 7.49 | 7.40 | 16 | 17 | 10 | 11 |
| 01/24/90 | 2.09 | 0.54 | | 0.135 | | | | | | 1 | 1 | 1 | 1 | 0 | 0 | 4 | 7.33 | 7.39 | 16 | 18 | 9 | 7 |
| 01/29/90 | 3.81 | 2.09 | 1.242 | 0.523 | 0.311 | | 400 | | | 1 | 1 | 1 | 1 | 0 | 0 | 4 | 7.18 | 7.50 | 15 | 17 | 9 | 10 |
| 01/30/90 | 4.15 | 2.22 | | 0.555 | | | | | | 1 | 1 | 1 | 1 | 0 | 0 | 4 | 7.06 | 7.17 | 18 | 17 | 2 | 4 |
| 01/31/90 | 3.19 | 1.43 | | 0.358 | | | | | | 1 | 1 | 1 | 1 | 0 | 0 | 4 | 7.12 | 7.22 | 15 | 15 | 2 | 8 |
| 02/01/90 | 2.78 | 1.14 | 1.818 | 0.570 | 0.908 | | 161 | | | 0 | 0 | 0 | 0 | 1 | 1 | 2 | 7.29 | 7.33 | 18 | 15 | 6 | 9 |
| 02/05/90 | 2.59 | 0.94 | 1.452 | 0.470 | 0.726 | | 545 | | | 0 | 0 | 1 | 1 | 0 | 0 | 2 | 7.17 | 7.46 | 14 | 15 | 7 | 10 |
| 02/08/90 | 2.28 | 0.89 | 1.147 | 0.223 | 0.287 | | 72 | | | 0 | 0 | 1 | 1 | 1 | 1 | 4 | 7.31 | 7.40 | 14 | 15 | 11 | 9 |
| 02/07/90 | 2.22 | 1.44 | | 0.720 | | | | | | 0 | 0 | 0 | 0 | 1 | 1 | 2 | 7.23 | 7.17 | 16 | 17 | 8 | 12 |
| 02/13/90 | 2.14 | 0.83 | 0.872 | 0.315 | 0.486 | | 134 | | | 0 | 0 | 0 | 0 | 1 | 1 | 2 | 7.32 | 7.17 | 15 | 16 | 11 | 11 |
| 02/14/90 | 2.07 | 0.59 | | 0.295 | | | | | | 0 | 0 | 0 | 0 | 1 | 1 | 2 | 7.29 | 7.35 | 13 | 20 | 9 | 8 |
| 02/15/90 | 2.12 | 0.51 | | 0.255 | | | | | | 0 | 0 | 0 | 0 | 1 | 1 | 2 | 7.02 | 7.56 | 16 | 18 | 8 | 9 |
| 02/20/90 | 1.89 | 0.34 | 0.256 | 0.085 | 0.064 | | 69 | | | 1 | 1 | 0 | 0 | 1 | 1 | 4 | 7.20 | 7.25 | 16 | 15 | 4 | 9 |
| 02/21/90 | 1.99 | 0.27 | | 0.135 | | | | | | 1 | 1 | 0 | 0 | 0 | 0 | 2 | 7.38 | 7.47 | 15 | 17 | 5 | 12 |
| 02/26/90 | 2.21 | 0.47 | 1.207 | 0.235 | 0.604 | | 72 | | | 1 | 1 | 0 | 0 | 0 | 0 | 2 | 7.42 | 8.36 | 14 | 15 | 8 | 11 |
| 02/27/90 | 2.07 | 0.51 | | 0.255 | | | | | | 1 | 1 | 0 | 0 | 0 | 0 | 2 | 7.38 | 7.35 | 14 | 16 | 8 | 12 |
| 02/28/90 | 2.03 | 0.45 | | 0.225 | | | | | | 1 | 1 | 0 | 0 | 0 | 0 | 2 | 7.30 | 7.25 | 14 | 15 | 6 | 11 |
| 03/05/90 | 1.98 | 0.27 | 0.283 | 0.270 | 0.283 | | 19 | | | 1 | 0 | 0 | 0 | 0 | 0 | 1 | 6.87 | 7.61 | 15 | 17 | 15 | 12 |
| 03/06/90 | 1.86 | 0.32 | | 0.160 | | | | | | 1 | 1 | 0 | 0 | 0 | 0 | 2 | 7.29 | 7.50 | 15 | 15 | 8 | 7 |
| 03/08/90 | 1.87 | 0.34 | | 0.170 | | | | | | 1 | 1 | 0 | 0 | 0 | 0 | 2 | 7.09 | 7.82 | 15 | 16 | 16 | 14 |
| 03/12/90 | 1.93 | 0.47 | | 0.235 | | | | 2,800 | | 1 | 1 | 0 | 0 | 0 | 0 | 2 | 6.72 | 7.48 | 16 | 18 | 8 | 8 |
| 03/14/90 | 1.79 | 0.38 | 0.313 | 0.180 | 0.157 | | 26 | | | 0 | 0 | 0 | 0 | 1 | 1 | 2 | 7.41 | 7.04 | 16 | 20 | 19 | 10 |
| 03/15/90 | 1.78 | 0.35 | | 0.175 | | | | | | 0 | 0 | 0 | 0 | 1 | 1 | 2 | 6.98 | 7.56 | 17 | 19 | 7 | 8 |
| 03/19/90 | 2.24 | 0.64 | 0.420 | 0.320 | 0.210 | | 79 | | | 0 | 0 | 0 | 0 | 1 | 1 | 2 | 6.71 | 7.26 | 15 | 16 | 7 | 13 |
| 03/20/90 | 3.48 | 1.04 | | 0.260 | | | | | | 1 | 1 | 0 | 0 | 1 | 1 | 4 | 7.04 | 7.28 | 16 | 17 | 6 | 8 |
| 03/22/90 | 2.50 | 1.01 | | 0.253 | | | | | | 1 | 1 | 0 | 0 | 1 | 1 | 4 | 6.99 | 7.19 | 15 | 18 | 9 | 13 |
| 03/26/90 | 2.04 | 0.62 | 1.201 | 0.310 | 0.601 | | 225 | | | 1 | 1 | 0 | 0 | 0 | 0 | 2 | 7.28 | 7.36 | 16 | 18 | 10 | 11 |
| 03/27/90 | 1.92 | 0.46 | | 0.240 | | | | | | 1 | 1 | 0 | 0 | 0 | 0 | 2 | 7.30 | 7.39 | 17 | 18 | 6 | 10 |
| 03/28/90 | 1.90 | 0.45 | | 0.450 | | | | | | 1 | 0 | 0 | 0 | 0 | 0 | 1 | 7.17 | 7.40 | 16 | 19 | 13 | 12 |
| 03/29/90 | 1.95 | 0.43 | | 0.215 | | | | | | 0 | 0 | 1 | 1 | 0 | 0 | 2 | 7.21 | 7.00 | 16 | 16 | 11 | 11 |
| 04/02/90 | 2.44 | 0.79 | 1.115 | 0.198 | 0.279 | | 890 | | | 0 | 0 | 1 | 1 | 1 | 1 | 4 | 7.26 | 7.24 | 18 | 18 | 5 | 10 |
| 04/03/90 | 3.92 | 2.31 | 3.086 | 0.578 | 0.772 | | 6,700 | | | 0 | 0 | 1 | 1 | 1 | 1 | 4 | 6.90 | 7.17 | 15 | 17 | 6 | 11 |
| 04/04/90 | 3.10 | 1.43 | 1.995 | 0.238 | 0.333 | | 120 | | | 1 | 1 | 1 | 1 | 1 | 1 | 6 | 6.91 | 6.96 | 16 | 17 | 6 | 6 |
| 04/05/90 | 2.52 | 1.07 | 1.465 | 0.268 | 0.366 | | 86 | | | 1 | 1 | 0 | 0 | 1 | 1 | 4 | 6.97 | 6.98 | 16 | 16 | 3 | 11 |
| 04/06/90 | 2.43 | 0.85 | 1.276 | 0.213 | 0.319 | | 93 | | | 1 | 1 | 0 | 0 | 1 | 1 | 4 | 6.91 | 6.85 | 16 | 17 | 11 | 11 |
| 04/09/90 | 2.24 | 0.72 | 1.275 | 0.360 | 0.638 | | 256 | | | 1 | 1 | 0 | 0 | 0 | 0 | 2 | 6.82 | 7.12 | 17 | 19 | 6 | 9 |
| 04/10/90 | 2.33 | 0.87 | | 0.435 | | | | | | 1 | 1 | 0 | 0 | 0 | 0 | 2 | 7.06 | 7.08 | 17 | 17 | 11 | 7 |
| 04/11/90 | 2.35 | 0.85 | | 0.425 | | | | | | 1 | 1 | 0 | 0 | 0 | 0 | 2 | 6.82 | 7.27 | 16 | 18 | 7 | 13 |
| 04/16/90 | 2.69 | 1.09 | 1.688 | 0.182 | 0.281 | | 162 | | | 1 | 1 | 1 | 1 | 1 | 1 | 6 | 6.76 | 7.17 | 18 | 18 | 6 | 9 |
| 04/17/90 | 2.40 | 0.87 | | 0.218 | | | | | | 0 | 0 | 1 | 1 | 1 | 1 | 4 | 6.78 | 7.14 | 17 | 19 | 11 | 11 |
| 04/18/90 | 2.27 | 0.71 | | 0.178 | | | | | | 0 | 0 | 1 | 1 | 1 | 1 | 4 | 6.88 | 7.07 | 16 | 18 | 5 | 10 |
| 04/19/90 | 2.23 | 0.83 | | 0.158 | | | | | | 0 | 0 | 1 | 1 | 1 | 1 | 4 | 6.80 | 7.12 | 16 | 18 | 5 | 8 |
| 04/23/90 | 2.17 | 0.70 | 1.306 | 0.117 | 0.218 | | 279 | | | 1 | 1 | 1 | 1 | 1 | 1 | 6 | 6.73 | 7.08 | 17 | 20 | 6 | 11 |
| 04/24/90 | 1.95 | 0.46 | | 0.230 | | | | | | 1 | 1 | 0 | 0 | 0 | 0 | 2 | 7.22 | 10.76 | 17 | 19 | 8 | 13 |
| 04/25/90 | 1.88 | 0.46 | | 0.230 | | | | | | 1 | 1 | 0 | 0 | 0 | 0 | 2 | 7.09 | 6.99 | 19 | 20 | 11 | 8 |

TABLE 3-2. NEW PROVIDENCE WASTEWATER TREATMENT PLANT
DAILY OPERATOR'S LOG DATA

| DATE | FLOW (MGD) | | | | | FECAL COLIFORM | | ENTEROCOCCI ORGANISMS | | UV DISINFECTION | | | | | | | PLANT INFLUENT | | | | | |
|----------|------------------|------------------|-----------------------|----------------------|---------------------|-------------------------|-------------------------|------------------------|------------------------|--------------------|----|----|----|----|----|------------------------|----------------|----------------|--------------------|--------------------|------------------|------------------|
| | TOTAL PLANT INF. | TOTAL PLANT EFF. | INSTANT. FLOW THRU UV | EFF FLOW PER UV BANK | INST. Q PER UV BANK | INFLUENT (Fecal/100 ml) | EFFLUENT (Fecal/100 ml) | INFLUENT (Ent./100 ml) | EFFLUENT (Ent./100 ml) | BANKS IN OPERATION | | | | | | TOTAL # OF BANKS OPER. | PH A.M. (S.U.) | PH P.M. (S.U.) | TEMP. A.M. (deg C) | TEMP. P.M. (deg C) | SET. SOLIDS A.M. | SET. SOLIDS P.M. |
| | | | | | | | | | | 1A | 1B | 2A | 2B | 3A | 3B | | | | | | | |
| 04/26/90 | 1.83 | 0.44 | | 0.073 | | | | | | 1 | 1 | 1 | 1 | 1 | 1 | 6 | 6.83 | 6.94 | 20 | 20 | 12 | 12 |
| 04/27/90 | 1.86 | 0.38 | 0.318 | 0.190 | 0.159 | | 67 | | | 0 | 0 | 0 | 0 | 1 | 1 | 2 | 6.79 | 7.20 | 19 | 22 | 12 | 9 |
| 04/28/90 | 1.81 | 0.40 | 0.415 | 0.200 | 0.208 | | 16 | | | 0 | 0 | 0 | 0 | 1 | 1 | 2 | 6.95 | 6.76 | 19 | 19 | 4 | 8 |
| 04/29/90 | 1.61 | 0.34 | 0.287 | 0.085 | 0.072 | | 16 | | | 1 | 1 | 0 | 0 | 1 | 1 | 4 | 6.87 | 6.85 | 18 | 17 | 8 | 4 |
| 04/30/90 | 1.91 | 0.31 | 0.128 | 0.155 | 0.084 | | 33 | | | 1 | 1 | 0 | 0 | 0 | 0 | 2 | 7.02 | 7.01 | 17 | 19 | 13 | 13 |
| 05/01/90 | 2.07 | 0.47 | | 0.235 | | | | | | 1 | 1 | 0 | 0 | 0 | 0 | 2 | 7.23 | 7.17 | 18 | 20 | 5 | 8 |
| 05/02/90 | 1.79 | 0.31 | | 0.155 | | | | | | 1 | 1 | 0 | 0 | 0 | 0 | 2 | 6.92 | 7.19 | 19 | 20 | 12 | 20 |
| 05/03/90 | 1.75 | 0.31 | | 0.155 | | | | | | 1 | 1 | 0 | 0 | 0 | 0 | 2 | 6.92 | 7.07 | 19 | 20 | 13 | 11 |
| 05/07/90 | 1.99 | 0.38 | 0.479 | 0.095 | 0.120 | | 24 | | | 1 | 1 | 0 | 0 | 1 | 1 | 4 | 6.97 | 7.06 | 19 | 22 | 6 | 11 |
| 05/08/90 | 1.99 | 0.39 | | 0.195 | | | | | | 0 | 0 | 0 | 0 | 1 | 1 | 2 | 7.29 | 7.15 | 19 | 22 | 8 | 11 |
| 05/14/90 | 2.89 | 0.90 | 2.039 | 0.225 | 0.510 | | 128 | | | 1 | 1 | 0 | 0 | 1 | 1 | 4 | 6.90 | 7.11 | 18 | 21 | 3 | 4 |
| 05/15/90 | 2.50 | 0.90 | | 0.450 | | | | | | 0 | 0 | 0 | 0 | 1 | 1 | 2 | 6.83 | 7.06 | 18 | 19 | 9 | 10 |
| 05/22/90 | 2.27 | 0.62 | 0.988 | 0.310 | 0.494 | | 139 | | | 0 | 0 | 1 | 1 | 0 | 0 | 2 | 7.32 | 7.23 | 18 | 20 | 7 | 8 |
| 05/23/90 | 2.15 | 0.55 | | 0.275 | | | | | | 0 | 0 | 1 | 1 | 0 | 0 | 2 | 7.17 | 7.44 | 19 | 21 | 10 | 11 |
| 05/24/90 | 2.05 | 0.45 | | 0.225 | | | | | | 0 | 0 | 1 | 1 | 0 | 0 | 2 | 6.78 | 7.24 | 19 | 21 | 7 | 9 |
| 05/29/90 | 4.39 | 3.27 | | 1.835 | | | 45 | | | 0 | 0 | 1 | 1 | 0 | 0 | 2 | 7.02 | 7.01 | 19 | 21 | 12 | 11 |
| 05/31/90 | 2.80 | 1.16 | | 0.580 | | | | | | 0 | 0 | 0 | 0 | 1 | 1 | 2 | 6.85 | 7.09 | 18 | 21 | 9 | 7 |
| 06/04/90 | 2.20 | 0.65 | | 0.325 | | | 82 | | | 0 | 0 | 0 | 0 | 1 | 1 | 2 | 7.21 | 6.97 | 21 | 22 | 9 | 8 |
| 06/05/90 | 2.09 | 0.48 | | 0.230 | | | | | | 0 | 0 | 0 | 0 | 1 | 1 | 2 | 7.30 | 7.58 | 19 | 20 | 11 | 9 |
| 06/07/90 | 1.94 | 0.33 | | 0.165 | | | | | | 0 | 0 | 0 | 0 | 1 | 1 | 2 | 7.02 | 6.99 | 21 | 23 | 6 | 9 |
| 06/11/90 | 1.93 | 0.39 | 0.332 | 0.195 | 0.166 | | 60 | | | 0 | 0 | 0 | 0 | 1 | 1 | 2 | 7.31 | 6.86 | 20 | 22 | 7 | 9 |
| 06/12/90 | 1.94 | 0.45 | | 0.225 | | | | | | 1 | 1 | 0 | 0 | 0 | 0 | 2 | 6.90 | 7.54 | 20 | 22 | 8 | 7 |
| 06/13/90 | 1.79 | 0.34 | | 0.170 | | | | | | 1 | 1 | 0 | 0 | 0 | 0 | 2 | 7.27 | 7.54 | 20 | 23 | 7 | 8 |
| 06/14/90 | 1.87 | 0.39 | | 0.195 | | | | | | 1 | 1 | 0 | 0 | 0 | 0 | 2 | 7.28 | 7.51 | 20 | 23 | 9 | 9 |
| 06/19/90 | 2.35 | 0.80 | | 0.200 | | | 119 | | | 1 | 1 | 0 | 0 | 1 | 1 | 4 | 7.44 | 7.36 | 21 | 22 | 8 | 8 |
| 06/25/90 | 1.92 | 0.33 | | 0.165 | | | 71 | | | 0 | 0 | 0 | 0 | 1 | 1 | 2 | 7.12 | 7.49 | 20 | 22 | | 10 |
| 06/26/90 | 1.80 | 0.34 | | 0.170 | | | | | | 0 | 0 | 0 | 0 | 1 | 1 | 2 | 6.93 | 7.82 | 20 | 23 | 5 | 10 |
| 06/27/90 | 1.64 | 0.37 | | 0.185 | | | | | | 0 | 0 | 0 | 0 | 1 | 1 | 2 | 7.32 | 7.56 | 21 | 23 | 8 | 11 |
| 07/04/90 | 1.38 | 0.22 | | 0.220 | | | | | | 0 | 0 | 1 | 0 | 0 | 0 | 1 | 7.52 | 7.97 | 21 | 22 | 2 | 10 |
| 07/05/90 | 1.47 | 0.23 | | 0.230 | | | | | | 0 | 0 | 1 | 0 | 0 | 0 | 1 | 6.98 | 7.09 | 24 | 24 | 11 | 15 |
| 07/06/90 | 1.85 | 0.16 | | 0.160 | | | | 5,800 | | 0 | 0 | 1 | 0 | 0 | 0 | 1 | 6.97 | 6.89 | 22 | 25 | 9 | 8 |
| 07/07/90 | 1.46 | 0.09 | | 0.045 | | | | 5,300 | | 0 | 0 | 1 | 1 | 0 | 0 | 2 | 6.33 | 7.52 | 22 | 23 | 9 | 12 |
| 07/08/90 | 1.44 | 0.10 | | 0.050 | | | | 41,300 | | 0 | 0 | 1 | 1 | 0 | 0 | 2 | 7.12 | 8.03 | 22 | 23 | 4 | 20 |
| 07/09/90 | 1.55 | 0.19 | | 0.048 | | | 910 | | | 0 | 0 | 1 | 1 | 1 | 1 | 4 | 6.80 | 7.37 | 24 | 24 | 8 | 9 |
| 07/10/90 | 1.63 | 0.16 | 0.192 | 0.080 | 0.096 | | 830 | | | 0 | 0 | 0 | 0 | 1 | 1 | 2 | 6.70 | 7.04 | 23 | 24 | 25 | 8 |
| 07/12/90 | 1.80 | 0.23 | 0.333 | 0.058 | 0.083 | | 59 | | | 1 | 1 | 0 | 0 | 1 | 1 | 4 | 6.57 | 6.77 | 22 | 23 | 9 | 13 |
| 07/16/90 | 1.85 | 0.33 | 0.336 | 0.165 | 0.168 | | 153 | | | 1 | 1 | 0 | 0 | 0 | 0 | 2 | 6.99 | 7.12 | 23 | 23 | 12 | 8 |
| 07/17/90 | 1.88 | 0.29 | 0.256 | 0.145 | 0.128 | | 35 | | | 1 | 1 | 0 | 0 | 0 | 0 | 2 | 7.04 | 7.45 | 23 | 25 | 10 | 8 |
| 07/18/90 | 1.86 | 0.39 | 1.211 | 0.098 | 0.303 | | 133 | | | 1 | 1 | 0 | 0 | 1 | 1 | 4 | 7.01 | 7.21 | 23 | 25 | 6 | 5 |
| 07/19/90 | 1.87 | 0.25 | 0.256 | 0.125 | 0.128 | | 8,800 | | | 0 | 0 | 0 | 0 | 1 | 1 | 2 | 7.28 | 6.85 | 23 | 24 | 12 | 11 |
| 07/23/90 | 2.14 | 0.47 | 0.157 | 0.118 | 0.039 | | 113 | | | 1 | 1 | 0 | 0 | 1 | 1 | 4 | 6.61 | 6.75 | 25 | 27 | 7 | 7 |
| 07/25/90 | 1.95 | 0.26 | 0.267 | 0.140 | 0.144 | | 86 | | | 1 | 1 | 0 | 0 | 0 | 0 | 2 | 7.19 | 7.12 | 22 | 24 | 13 | 11 |
| 07/30/90 | 1.53 | 0.24 | 0.256 | 0.120 | 0.128 | | 54 | | | 1 | 1 | 0 | 0 | 0 | 0 | 2 | 7.15 | 6.94 | 23 | 25 | 8 | 8 |
| 07/31/90 | 1.70 | 0.15 | 0.192 | 0.075 | 0.096 | | 88 | | | 1 | 1 | 0 | 0 | 0 | 0 | 2 | 7.16 | 7.27 | 23 | 26 | 40 | 7 |
| 08/02/90 | 1.55 | 0.24 | | 0.120 | | | | | | 0 | 0 | 0 | 0 | 1 | 1 | 2 | 7.14 | 7.51 | 21 | 24 | 4 | 12 |
| 08/06/90 | 2.76 | 1.09 | 1.147 | 0.545 | 0.574 | | 62 | | | 1 | 1 | 0 | 0 | 0 | 0 | 2 | 7.29 | 7.01 | 24 | 25 | 2 | 8 |
| 08/07/90 | 2.28 | 0.78 | | 0.195 | | | | | | 1 | 1 | 0 | 0 | 1 | 1 | 4 | 6.93 | 7.12 | 23 | 25 | 4 | 11 |
| 08/09/90 | 1.88 | 0.27 | | 0.068 | | | | | | 1 | 1 | 0 | 0 | 1 | 1 | 4 | 7.36 | 7.31 | 24 | 25 | 5 | 20 |

**TABLE 3-2. NEW PROVIDENCE WASTEWATER TREATMENT PLANT
DAILY OPERATOR'S LOG DATA**

| DATE | FLOW (MGD) | | | | | FECAL COLIFORM | | ENTEROCOCCI ORGANISMS | | UV DISINFECTION | | | | | | | PLANT INFLUENT | | | | | |
|----------|------------------|------------------|-----------------------|----------------------|---------------------|-------------------------|-------------------------|------------------------|------------------------|--------------------|----|----|----|----|----|------------------------|----------------|----------------|--------------------|--------------------|------------------|------------------|
| | TOTAL PLANT INF. | TOTAL PLANT EFF. | INSTANT. FLOW THRU UV | EFF FLOW PER UV BANK | INST. Q PER UV BANK | INFLUENT (Fecal/100 ml) | EFFLUENT (Fecal/100 ml) | INFLUENT (Ent./100 ml) | EFFLUENT (Ent./100 ml) | BANKS IN OPERATION | | | | | | | PH A.M. (S.U.) | PH P.M. (S.U.) | TEMP. A.M. (deg C) | TEMP. P.M. (deg C) | SET. SOLIDS A.M. | SET. SOLIDS P.M. |
| | | | | | | | | | | 1A | 1B | 2A | 2B | 3A | 3B | TOTAL # OF BANKS OPER. | | | | | | |
| 08/13/90 | 2.23 | 1.06 | 1.080 | 0.530 | 0.540 | | 112 | | | 0 | 0 | 0 | 0 | 1 | 1 | 2 | 6.63 | 7.09 | 24 | 26 | 10 | 11 |
| 08/14/90 | 2.08 | 0.72 | | 0.360 | | | | | | 0 | 0 | 0 | 0 | 1 | 1 | 2 | 7.07 | 7.08 | 24 | 25 | 9 | 9 |
| 08/15/90 | 1.82 | 0.34 | | 0.170 | | | | | | 0 | 0 | 0 | 0 | 1 | 1 | 2 | 6.92 | 7.29 | 23 | 25 | 9 | 9 |
| 08/20/90 | 1.71 | 0.20 | 0.252 | 0.050 | 0.063 | | 71 | | | 1 | 1 | 0 | 0 | 1 | 1 | 4 | 7.05 | 7.39 | 22 | 23 | 9 | 18 |
| 08/21/90 | 1.87 | 0.31 | 0.258 | 0.155 | 0.128 | | | | | 1 | 1 | 0 | 0 | 0 | 0 | 2 | 7.18 | 7.25 | 22 | 24 | 10 | 19 |
| 08/22/90 | 1.85 | 0.37 | | 0.185 | | | | | | 1 | 1 | 0 | 0 | 0 | 0 | 2 | 6.89 | 7.50 | 23 | 25 | 11 | 13 |
| 08/23/90 | 1.79 | 0.33 | | 0.165 | | | | | | 1 | 1 | 0 | 0 | 0 | 0 | 2 | 6.65 | 7.47 | 23 | 25 | 10 | 12 |
| 08/27/90 | 1.71 | 0.29 | 0.287 | 0.145 | 0.144 | | 37 | | | 1 | 1 | 0 | 0 | 0 | 0 | 2 | 7.21 | 7.00 | 24 | 24 | 18 | 15 |
| 08/29/90 | 2.18 | 0.53 | 0.287 | 0.265 | 0.144 | | | | | 1 | 1 | 0 | 0 | 0 | 0 | 2 | 6.65 | 7.14 | 24 | 26 | 5 | 13 |
| 08/30/90 | 2.00 | 0.45 | | 0.225 | | | | | | 1 | 1 | 0 | 0 | 0 | 0 | 2 | 6.70 | 6.90 | 22 | 25 | 5 | 18 |
| 09/04/90 | 1.69 | 0.21 | | 0.105 | | 5,600 | | | | 0 | 0 | 0 | 0 | 1 | 1 | 2 | 7.10 | 7.42 | 22 | 24 | 15 | 13 |
| 09/05/90 | 1.66 | 0.24 | | 0.120 | | | 37 | | | 0 | 0 | 0 | 0 | 1 | 1 | 2 | 7.03 | 7.11 | 23 | 25 | 10 | 10 |
| 09/08/90 | 1.72 | 0.26 | 0.258 | 0.130 | 0.128 | | 27 | | | 0 | 0 | 0 | 0 | 1 | 1 | 2 | 7.57 | 7.22 | 24 | 25 | 12 | 13 |
| 09/11/90 | 1.88 | 0.14 | 0.156 | 0.070 | 0.078 | | 141 | | | 1 | 1 | 0 | 0 | 0 | 0 | 2 | 7.33 | 7.31 | 24 | 26 | 9 | 7 |
| 09/12/90 | 1.87 | 0.14 | 0.159 | 0.070 | 0.080 | | | | | 1 | 1 | 0 | 0 | 0 | 0 | 2 | 6.98 | 7.36 | 25 | 25 | 12 | 10 |
| 09/13/90 | 1.81 | 0.22 | | 0.110 | | | | | | 1 | 1 | 0 | 0 | 0 | 0 | 2 | 6.77 | 7.15 | 24 | 25 | 17 | 8 |
| 09/17/90 | 1.71 | 0.31 | 0.318 | 0.078 | 0.080 | | 22 | | | 1 | 1 | 1 | 1 | 0 | 0 | 4 | 7.12 | 7.29 | 21 | 24 | 9 | 8 |
| 09/19/90 | 1.87 | 0.19 | 0.319 | 0.048 | 0.080 | | | | | 1 | 1 | 1 | 1 | 0 | 0 | 4 | 7.34 | 7.15 | 23 | 24 | 5 | 12 |
| 09/20/90 | 1.86 | 0.20 | | 0.050 | | | | | | 1 | 1 | 1 | 1 | 0 | 0 | 4 | 7.16 | 7.23 | 22 | 24 | 12 | 11 |
| 09/24/90 | 1.70 | 0.29 | 0.318 | 0.145 | 0.159 | | 52 | | | 0 | 0 | 1 | 1 | 0 | 0 | 2 | 7.29 | 7.25 | 22 | 23 | 3 | 30 |
| 09/25/90 | 1.61 | 0.25 | 0.187 | 0.125 | 0.094 | | | | | 0 | 0 | 1 | 1 | 0 | 0 | 2 | 7.11 | 7.32 | 22 | 23 | 8 | 11 |
| 09/26/90 | 1.72 | 0.10 | | 0.050 | | | | | | 0 | 0 | 1 | 1 | 0 | 0 | 2 | 7.28 | 7.38 | 23 | 24 | 11 | 8 |
| 09/27/90 | 1.70 | 0.17 | | 0.085 | | | | | | 0 | 0 | 1 | 1 | 0 | 0 | 2 | 6.83 | 7.43 | 22 | 25 | 6 | 9 |
| 10/01/90 | 1.61 | 0.23 | 0.318 | 0.115 | 0.159 | | 80 | | | 0 | 0 | 1 | 1 | 0 | 0 | 2 | 7.07 | 7.27 | 23 | 24 | 11 | 11 |
| 10/03/90 | 1.56 | 0.21 | | 0.105 | | | | | | 0 | 0 | 1 | 1 | 0 | 0 | 2 | 7.29 | 7.23 | 22 | 24 | 6 | 7 |
| 10/04/90 | 1.52 | 0.22 | | 0.110 | | | | | | 0 | 0 | 1 | 1 | 0 | 0 | 2 | 7.57 | 6.88 | 23 | 23 | 13 | 10 |
| 10/09/90 | 2.42 | 1.01 | 1.596 | 0.253 | 0.399 | | 239 | | | 1 | 1 | 1 | 1 | 0 | 0 | 4 | 7.01 | 6.95 | 23 | 25 | 2 | 8 |
| 10/10/90 | 1.87 | 0.48 | 0.968 | 0.115 | 0.242 | | | | | 1 | 1 | 1 | 1 | 0 | 0 | 4 | 7.30 | 6.58 | 23 | 25 | 13 | 10 |
| 10/11/90 | 1.92 | 0.39 | | 0.195 | | | | | | 1 | 1 | 0 | 0 | 0 | 0 | 2 | 6.80 | 7.02 | 23 | 24 | 7 | 10 |
| 10/15/90 | 2.25 | 0.78 | 1.370 | 0.390 | 0.685 | | 380 | | | 1 | 1 | 0 | 0 | 0 | 0 | 2 | 7.25 | 7.08 | 22 | 25 | 10 | 8 |
| 10/16/90 | 2.00 | 0.47 | | 0.118 | | | | | | 1 | 1 | 1 | 1 | 0 | 0 | 4 | 6.90 | 6.99 | 20 | 23 | 11 | 8 |
| 10/17/90 | 1.91 | 0.37 | 0.795 | 0.093 | 0.199 | | | | | 1 | 1 | 1 | 1 | 0 | 0 | 4 | 7.17 | 7.10 | 23 | 24 | 15 | 9 |
| 10/18/90 | 2.59 | 0.95 | | 0.475 | | | | | | 0 | 0 | 1 | 1 | 0 | 0 | 2 | 7.08 | 6.94 | 24 | 24 | 8 | 8 |
| 10/22/90 | 1.97 | 0.35 | 0.287 | 0.175 | 0.144 | | 41 | | | 0 | 0 | 1 | 1 | 0 | 0 | 2 | 7.19 | 6.88 | 22 | 24 | 9 | 8 |
| 10/23/90 | 3.11 | 0.85 | 0.785 | 0.425 | 0.383 | | | | | 0 | 0 | 1 | 1 | 0 | 0 | 2 | 7.16 | 6.85 | 22 | 24 | 13 | 9 |
| 10/25/90 | 2.17 | 0.74 | | 0.370 | | | | | | 1 | 1 | 0 | 0 | 0 | 0 | 2 | 7.39 | 7.03 | 21 | 22 | 4 | 11 |
| 10/30/90 | 2.02 | 0.33 | 0.256 | 0.165 | 0.128 | | 37 | | | 1 | 1 | 0 | 0 | 0 | 0 | 2 | 7.31 | 7.28 | 20 | 22 | 9 | 11 |
| 11/05/90 | 1.79 | 0.39 | 0.256 | 0.098 | 0.084 | | 8 | | | 1 | 1 | 1 | 1 | 0 | 0 | 4 | 7.40 | 7.12 | 21 | 23 | 10 | 8 |
| 11/06/90 | 1.65 | 0.27 | 0.448 | 0.135 | 0.223 | | | | | 0 | 0 | 1 | 1 | 0 | 0 | 2 | 6.80 | 7.33 | 22 | 22 | 7 | 8 |
| 11/07/90 | 1.75 | 0.14 | | 0.070 | | | | | | 0 | 0 | 1 | 1 | 0 | 0 | 2 | 7.37 | 7.26 | 21 | 22 | 13 | 9 |
| 11/13/90 | 2.23 | 0.53 | 0.995 | 0.133 | 0.249 | | 61 | | | 0 | 0 | 1 | 1 | 1 | 1 | 4 | 7.08 | 6.61 | 19 | 20 | 11 | 11 |
| 11/14/90 | 2.13 | 0.43 | 0.775 | 0.108 | 0.164 | | | | | 0 | 0 | 1 | 1 | 1 | 1 | 4 | 6.50 | 7.40 | 19 | 20 | 6 | 7 |
| 11/15/90 | 2.05 | 0.48 | | 0.120 | | | | | | 0 | 0 | 1 | 1 | 1 | 1 | 4 | 7.12 | 6.90 | 20 | 21 | 7 | 7 |
| 11/19/90 | 1.94 | 0.34 | 0.227 | 0.170 | 0.114 | | 5 | | | 0 | 0 | 0 | 0 | 1 | 1 | 2 | 6.70 | 6.89 | 19 | 19 | 10 | 10 |
| 11/20/90 | 1.84 | 0.30 | 0.228 | 0.150 | 0.114 | | | | | 0 | 0 | 0 | 0 | 1 | 1 | 2 | 7.04 | 7.28 | 19 | 18 | 9 | 11 |
| 11/26/90 | 1.96 | 0.41 | 0.886 | 0.205 | 0.443 | | 196 | | | 1 | 1 | 0 | 0 | 0 | 0 | 2 | 7.52 | 7.32 | 19 | 20 | 9 | 8 |
| 11/27/90 | 1.86 | 0.35 | 0.335 | 0.175 | 0.168 | | | | | 1 | 1 | 0 | 0 | 0 | 0 | 2 | 6.86 | 6.86 | 20 | 20 | 10 | 7 |
| 11/28/90 | 1.86 | 0.34 | | 0.170 | | | | | | 1 | 1 | 0 | 0 | 0 | 0 | 2 | 7.28 | 7.38 | 20 | 21 | 7 | 9 |

**TABLE 3-2. NEW PROVIDENCE WASTEWATER TREATMENT PLANT
DAILY OPERATOR'S LOG DATA**

| DATE | FLOW (MGD) | | | | | FECAL COLIFORM | | ENTEROCOCCI ORGANISMS | | UV DISINFECTION | | | | | | PLANT INFLUENT | | | | | | |
|----------|------------------|------------------|-----------------------|----------------------|---------------------|-------------------------|-------------------------|------------------------|------------------------|--------------------|----|----|----|----|----|------------------------|----------------|----------------|-------------------|--------------------|------------------|------------------|
| | TOTAL PLANT INF. | TOTAL PLANT EFF. | INSTANT. FLOW THRU UV | EFF FLOW PER UV BANK | INST. Q PER UV BANK | INFLUENT (Fecal/100 ml) | EFFLUENT (Fecal/100 ml) | INFLUENT (Ent./100 ml) | EFFLUENT (Ent./100 ml) | BANKS IN OPERATION | | | | | | TOTAL # OF BANKS OPER. | PH A.M. (S.U.) | PH P.M. (S.U.) | TEMP. A.M (deg C) | TEMP. P.M. (deg C) | SET. SOLIDS A.M. | SET. SOLIDS P.M. |
| | | | | | | | | | | 1A | 1B | 2A | 2B | 3A | 3B | | | | | | | |
| 12/03/90 | 3.10 | 1.35 | 0.227 | 0.675 | 0.114 | | 21 | | | 1 | 1 | 0 | 0 | 0 | 0 | 2 | 7.57 | 6.95 | 18 | 20 | 15 | 11 |
| 12/04/90 | 4.33 | 1.62 | 3.768 | 0.405 | 0.942 | | 21,800 | | | 1 | 1 | 1 | 1 | 0 | 0 | 4 | 6.59 | 6.74 | 18 | 18 | 3 | 3 |
| 12/06/90 | 2.76 | 1.03 | | 0.258 | | | | | | 1 | 1 | 1 | 1 | 0 | 0 | 4 | 6.73 | 6.83 | 17 | 18 | 8 | 17 |
| 12/10/90 | 2.19 | 0.54 | 1.203 | 0.135 | 0.301 | | 177 | | | 1 | 1 | 1 | 1 | 0 | 0 | 4 | 6.75 | 7.12 | 17 | 18 | 7 | 7 |
| 12/12/90 | 2.05 | 0.39 | 0.776 | 0.195 | 0.388 | | | | | 0 | 0 | 1 | 1 | 0 | 0 | 2 | 7.33 | 6.94 | 17 | 19 | 11 | 11 |
| 12/13/90 | 2.03 | 0.36 | | 0.180 | | | | | | 0 | 0 | 1 | 1 | 0 | 0 | 2 | 7.20 | 7.30 | 18 | 19 | 11 | 12 |
| 12/17/90 | 2.19 | 0.55 | 0.898 | 0.275 | 0.499 | | 210 | | | 0 | 0 | 0 | 0 | 1 | 1 | 2 | 7.12 | 7.08 | 17 | 18 | 7 | 12 |
| 12/18/90 | 2.84 | 1.04 | 1.687 | 0.520 | 0.844 | | 4,600 | | | 0 | 0 | 0 | 0 | 1 | 1 | 2 | 6.72 | 6.68 | 17 | 17 | 8 | 10 |
| 12/19/90 | 2.57 | 0.78 | | 0.390 | | | | | | 0 | 0 | 0 | 0 | 1 | 1 | 2 | 7.03 | 6.69 | 17 | 18 | 9 | 9 |
| 12/25/90 | 2.74 | 0.97 | | 0.243 | | | | | | 1 | 1 | 0 | 0 | 1 | 1 | 4 | 7.15 | 7.18 | 14 | 15 | 3 | 10 |
| 12/26/90 | 2.53 | 0.82 | | 0.205 | | | 90 | | | 1 | 1 | 0 | 0 | 1 | 1 | 4 | 7.06 | 7.31 | 15 | 18 | 4 | 12 |
| 12/27/90 | 2.35 | 0.70 | | 0.175 | | | | | | 1 | 1 | 0 | 0 | 1 | 1 | 4 | 7.32 | 7.23 | 15 | 15 | 4 | 9 |
| 01/01/91 | 2.68 | 1.14 | | 0.285 | | | | | | 1 | 1 | 1 | 1 | 0 | 0 | 4 | 6.97 | 6.66 | 16 | 15 | 2 | 8 |
| 01/02/91 | 2.69 | 1.09 | | 0.273 | | | | | | 1 | 1 | 1 | 1 | 0 | 0 | 4 | 6.87 | 7.16 | 16 | 17 | 10 | 9 |
| 01/03/91 | 2.52 | 0.92 | 1.406 | 0.230 | 0.352 | | 282 | | | 1 | 1 | 1 | 1 | 0 | 0 | 4 | 6.92 | 7.10 | 16 | 17 | 7 | 7 |
| 01/04/91 | 2.41 | 0.89 | 1.370 | 0.445 | 0.885 | | | 242 | | 0 | 0 | 1 | 1 | 0 | 0 | 2 | 6.61 | 6.50 | 15 | 18 | 6 | 8 |
| 01/07/91 | 2.26 | 0.89 | 1.211 | 0.345 | 0.606 | | 181 | | | 0 | 0 | 1 | 1 | 0 | 0 | 2 | 7.43 | 7.00 | 16 | 18 | 8 | 13 |
| 01/08/91 | 2.13 | 0.60 | 1.115 | 0.300 | 0.558 | | | 441 | | 0 | 0 | 1 | 1 | 0 | 0 | 2 | 7.21 | 6.80 | 16 | 17 | 9 | 9 |
| 01/14/91 | 2.49 | 0.84 | 1.370 | 0.420 | 0.685 | | 710 | | | 1 | 1 | 0 | 0 | 0 | 0 | 2 | 7.27 | 6.84 | 15 | 15 | 4 | 7 |
| 01/15/91 | 2.34 | 0.81 | | 0.203 | | | 135 | | | 1 | 1 | 0 | 0 | 1 | 1 | 4 | 6.75 | 7.09 | 15 | 15 | 9 | 11 |
| 01/16/91 | 4.84 | 3.04 | 3.358 | 0.780 | 0.840 | | | 3,230 | | 1 | 1 | 0 | 0 | 1 | 1 | 4 | 6.81 | 6.68 | 16 | 17 | 7 | 7 |
| 01/22/91 | 2.48 | 0.87 | 1.465 | 0.218 | 0.366 | | 133 | | | 1 | 1 | 0 | 0 | 1 | 1 | 4 | 7.30 | 6.47 | 14 | 15 | 6 | 7 |
| 01/23/91 | 2.36 | 0.80 | 1.211 | 0.200 | 0.303 | | | 200 | | 1 | 1 | 0 | 0 | 1 | 1 | 4 | 6.95 | 6.94 | 14 | 18 | 8 | 9 |
| 01/24/91 | 2.32 | 0.72 | | 0.180 | | | | | | 0 | 0 | 1 | 1 | 1 | 1 | 4 | 6.87 | 7.18 | 15 | 18 | 4 | 10 |
| 01/29/91 | 2.15 | 0.53 | 1.105 | 0.088 | 0.184 | | 40 | | | 1 | 1 | 1 | 1 | 1 | 1 | 6 | 7.37 | 6.60 | 15 | 17 | 9 | 10 |
| 01/30/91 | 2.27 | 0.70 | | 0.175 | | | | 73 | | 1 | 1 | 1 | 1 | 0 | 0 | 4 | 6.65 | 6.90 | 15 | 17 | 10 | 11 |
| 02/04/91 | 2.12 | 0.51 | 0.880 | 0.128 | 0.220 | | 36 | | | 1 | 1 | 1 | 1 | 0 | 0 | 4 | 6.90 | 6.93 | 17 | 18 | 9 | 22 |
| 02/05/91 | 2.02 | 0.47 | | 0.118 | | | | | | 1 | 1 | 0 | 0 | 1 | 1 | 4 | 6.89 | 6.95 | 17 | 18 | 9 | 14 |
| 02/07/91 | 2.74 | 1.11 | | 0.278 | | | | | | 1 | 1 | 0 | 0 | 1 | 1 | 4 | 6.94 | 6.90 | 16 | 16 | 11 | 11 |
| 02/12/91 | 1.81 | 0.54 | | 0.270 | | | | | | 0 | 0 | 1 | 1 | 0 | 0 | 2 | 8.34 | 7.20 | 13 | 14 | 10 | 8 |
| 02/13/91 | 2.09 | 0.36 | | 0.180 | | | 213 | | | 0 | 0 | 1 | 1 | 0 | 0 | 2 | 7.10 | 6.88 | 15 | 17 | 9 | 9 |
| 02/19/91 | 2.53 | 0.66 | 1.275 | 0.165 | 0.319 | | 280 | | | 1 | 1 | 0 | 0 | 1 | 1 | 4 | 6.80 | 6.95 | 15 | 17 | 10 | 11 |
| 02/21/91 | 2.37 | 0.80 | | 0.150 | | | | | | 1 | 1 | 0 | 0 | 1 | 1 | 4 | 6.99 | 7.26 | 16 | 16 | 8 | 7 |
| 02/25/91 | 1.99 | 0.49 | 0.895 | 0.082 | 0.149 | | 21 | | | 1 | 1 | 1 | 1 | 1 | 1 | 6 | 7.06 | 6.85 | 15 | 17 | 9 | 10 |
| 02/26/91 | 1.83 | 0.46 | | 0.115 | | | | | | 0 | 0 | 1 | 1 | 1 | 1 | 4 | 6.95 | 7.07 | 16 | 16 | 6 | 9 |
| 03/04/91 | 3.91 | 2.33 | 3.112 | 0.388 | 0.519 | | 144 | | | 1 | 1 | 1 | 1 | 1 | 1 | 6 | 6.80 | 6.99 | 15 | 17 | 2 | 7 |
| 03/05/91 | 3.19 | 2.03 | | 0.338 | | | | | | 1 | 1 | 1 | 1 | 1 | 1 | 6 | 6.86 | 6.68 | 15 | 17 | 5 | 6 |
| 03/06/91 | 3.13 | 1.37 | | 0.343 | | | | | | 1 | 1 | 0 | 0 | 1 | 1 | 4 | 6.95 | 7.10 | 15 | 17 | 10 | 8 |
| 03/07/91 | 3.04 | 1.24 | | 0.310 | | | | | | 1 | 1 | 0 | 0 | 1 | 1 | 4 | 6.61 | 6.94 | 15 | 17 | 13 | 8 |
| 03/11/91 | 2.28 | 0.72 | 1.179 | 0.180 | 0.295 | | 51 | | | 1 | 1 | 0 | 0 | 1 | 1 | 4 | 6.95 | 6.82 | 15 | 16 | 10 | 8 |
| 03/12/91 | 2.06 | 0.58 | | 0.145 | | | | | | 1 | 1 | 1 | 1 | 0 | 0 | 4 | 6.95 | 6.96 | 15 | 15 | 12 | 9 |
| 03/13/91 | 2.02 | 0.57 | 1.080 | 0.143 | 0.270 | | | | | 1 | 1 | 1 | 1 | 0 | 0 | 4 | 6.86 | 7.14 | 15 | 18 | 9 | 8 |
| 03/14/91 | 2.23 | 0.89 | | 0.173 | | | | | | 1 | 1 | 1 | 1 | 0 | 0 | 4 | 6.82 | 7.17 | 15 | 17 | 7 | 7 |
| 03/18/91 | 2.83 | 1.20 | 1.624 | 0.200 | 0.271 | | 87 | | | 1 | 1 | 1 | 1 | 1 | 1 | 6 | 7.07 | 7.14 | 16 | 17 | 9 | 8 |
| 03/19/91 | 2.52 | 1.00 | | 0.250 | | | | | | 0 | 0 | 1 | 1 | 1 | 1 | 4 | 7.02 | 6.91 | 16 | 17 | 10 | 9 |
| 03/20/91 | 2.42 | 0.75 | 1.180 | 0.188 | 0.295 | | | | | 1 | 1 | 0 | 1 | 1 | 1 | 4 | 6.86 | 6.78 | 15 | 16 | 11 | 7 |
| 03/21/91 | 2.28 | 0.72 | | 0.180 | | | | | | 0 | 0 | 1 | 1 | 1 | 1 | 4 | 6.74 | 7.19 | 15 | 16 | 6 | 7 |
| 03/22/91 | 2.30 | 0.70 | 1.167 | 0.175 | 0.292 | | | | | 0 | 0 | 1 | 1 | 1 | 1 | 4 | 6.76 | 7.18 | 16 | 16 | 7 | 8 |

PAGE 110

**TABLE 3-2. NEW PROVIDENCE WASTEWATER TREATMENT PLANT
DAILY OPERATOR'S LOG DATA**

| DATE | FLOW (MGD) | | | | | FECAL COLIFORM | | ENTEROCOCCI ORGANISMS | | UV DISINFECTION | | | | | | PLANT INFLUENT | | | | | | |
|----------|------------------|------------------|-----------------------|----------------------|---------------------|------------------------|------------------------|------------------------|------------------------|--------------------|----|----|----|----|----|------------------------|----------------|----------------|--------------------|--------------------|------------------|------------------|
| | TOTAL PLANT INF. | TOTAL PLANT EFF. | INSTANT. FLOW THRU UV | EFF FLOW PER UV BANK | INST. Q PER UV BANK | INFLUENT (Fecal/100 m) | EFFLUENT (Fecal/100 m) | INFLUENT (Ent./100 ml) | EFFLUENT (Ent./100 ml) | BANKS IN OPERATION | | | | | | TOTAL # OF BANKS OPER. | PH A.M. (S.U.) | PH P.M. (S.U.) | TEMP. A.M. (deg C) | TEMP. P.M. (deg C) | SET. SOLIDS A.M. | SET. SOLIDS P.M. |
| | | | | | | | | | | 1A | 1B | 2A | 2B | 3A | 3B | | | | | | | |
| 03/25/91 | 2.22 | 0.84 | 1.147 | 0.180 | 0.287 | | 23 | | 80 | 0 | 0 | 1 | 1 | 1 | 1 | 4 | 7.04 | 7.19 | 15 | 17 | 13 | 8 |
| 03/26/91 | 2.18 | 0.89 | | 0.173 | | | | | | 1 | 1 | 0 | 0 | 1 | 1 | 4 | 7.09 | 7.10 | 15 | 18 | 9 | 9 |
| 03/27/91 | 2.23 | 0.73 | 0.108 | 0.183 | 0.027 | | | | 134 | 1 | 1 | 0 | 0 | 1 | 1 | 4 | 6.93 | 6.90 | 16 | 16 | 15 | 8 |
| 04/01/91 | 2.19 | 0.56 | 1.080 | 0.140 | 0.270 | | 71 | | 89 | 1 | 1 | 0 | 0 | 1 | 1 | 4 | 7.26 | 7.42 | 16 | 18 | 20 | 11 |
| 04/03/91 | 2.04 | 0.38 | 0.701 | 0.095 | 0.175 | | | | 145 | 1 | 1 | 1 | 1 | 0 | 0 | 4 | 6.88 | 7.00 | 15 | 18 | 10 | 9 |
| 04/04/91 | 2.01 | 0.45 | | 0.113 | | | | | | 1 | 1 | 1 | 1 | 0 | 0 | 4 | 6.85 | 6.76 | 16 | 18 | 11 | 11 |
| 04/08/91 | 1.90 | 0.41 | 0.880 | 0.103 | 0.215 | | 61 | | 74 | 1 | 1 | 1 | 1 | 0 | 0 | 4 | 7.44 | 7.35 | 18 | 21 | 11 | 12 |
| 04/10/91 | 1.84 | 0.39 | | 0.098 | | | | | | 0 | 0 | 1 | 1 | 1 | 1 | 4 | 6.85 | 7.40 | 20 | 21 | 10 | 9 |
| 04/12/91 | 1.82 | 0.26 | 0.287 | 0.065 | 0.072 | | | | 13 | 1 | 1 | 0 | 0 | 1 | 1 | 4 | 7.25 | 6.56 | 17 | 20 | 15 | 11 |
| 04/15/91 | 2.04 | 0.46 | 0.970 | 0.115 | 0.243 | | 31 | | 38 | 1 | 1 | 0 | 0 | 1 | 1 | 4 | 7.05 | 7.24 | 18 | 18 | 12 | 13 |
| 04/16/91 | 1.90 | 0.44 | | 0.110 | | | | | | 1 | 1 | 0 | 0 | 1 | 1 | 4 | 7.24 | 6.99 | 18 | 19 | 10 | 11 |
| 04/17/91 | 1.92 | 0.46 | 0.870 | 0.115 | 0.218 | | | | 30 | 1 | 1 | 0 | 0 | 1 | 1 | 4 | 7.25 | 7.13 | 18 | 20 | 20 | 13 |
| 04/22/91 | 3.29 | 1.57 | | 0.262 | | | 183 | | 203 | 1 | 1 | 1 | 1 | 1 | 1 | 6 | 6.99 | 7.13 | 15 | 16 | 5 | 7 |
| 04/24/91 | 3.11 | 1.85 | | 0.413 | | | | | | 1 | 1 | 1 | 1 | 0 | 0 | 4 | 6.84 | 6.53 | 16 | 17 | 5 | 13 |
| 04/29/91 | 2.21 | 0.64 | 1.086 | 0.160 | 0.272 | | 78 | | 73 | 1 | 1 | 1 | 1 | 0 | 0 | 4 | 7.49 | 7.57 | 19 | 18 | 9 | 11 |
| 05/01/91 | 2.08 | 0.45 | 0.956 | 0.113 | 0.239 | | | | 129 | 0 | 0 | 1 | 1 | 1 | 1 | 4 | 7.24 | 7.31 | 18 | 21 | 9 | 9 |
| 05/02/91 | 1.99 | 0.44 | | 0.110 | | | | | | 0 | 0 | 1 | 1 | 1 | 1 | 4 | 7.41 | 7.57 | 18 | 21 | 7 | 8 |
| 05/06/91 | 2.95 | 1.91 | 1.654 | 0.478 | 0.414 | | 50 | | 112 | 0 | 0 | 1 | 1 | 1 | 1 | 4 | 7.20 | 7.27 | 18 | 20 | 12 | 9 |
| 05/07/91 | 2.58 | 1.04 | | 0.260 | | | | | | 0 | 0 | 1 | 1 | 1 | 1 | 4 | 7.13 | 7.40 | 18 | 19 | 5 | 7 |
| 05/08/91 | 2.24 | 0.97 | 1.210 | 0.243 | 0.303 | | | | 120 | 1 | 1 | 0 | 0 | 1 | 1 | 4 | 7.30 | 7.23 | 18 | 20 | 8 | 9 |
| 05/14/91 | 2.10 | 0.49 | 0.860 | 0.123 | 0.215 | | 16 | | 44 | 1 | 1 | 1 | 1 | 0 | 0 | 4 | 7.08 | 7.49 | 20 | 23 | 10 | 7 |
| 05/16/91 | 1.90 | 0.38 | 0.795 | 0.095 | 0.199 | | | | 12 | 1 | 1 | 1 | 1 | 0 | 0 | 4 | 6.91 | 7.55 | 21 | 23 | 5 | 7 |
| 05/20/91 | 1.72 | 0.37 | 0.351 | 0.093 | 0.088 | | 2 | | 10 | 0 | 0 | 1 | 1 | 1 | 1 | 4 | 7.55 | 7.90 | 19 | 22 | 9 | 14 |
| 05/21/91 | 1.73 | 0.37 | | 0.093 | | | | | | 1 | 1 | 0 | 0 | 1 | 1 | 4 | 7.57 | 7.55 | 20 | 22 | 8 | 10 |
| 05/22/91 | 1.75 | 0.39 | | 0.098 | | | | | | 1 | 1 | 0 | 0 | 1 | 1 | 4 | 7.50 | 7.44 | 21 | 22 | 9 | 11 |
| 05/28/91 | 1.89 | 0.59 | 0.733 | 0.148 | 0.183 | | 59 | | 71 | 1 | 1 | 0 | 0 | 1 | 1 | 4 | 7.53 | 7.57 | 22 | 24 | 7 | 9 |
| 05/30/91 | 1.92 | 0.37 | | 0.093 | | | | | | 1 | 1 | 1 | 1 | 0 | 0 | 4 | 7.30 | 7.80 | 24 | 26 | 9 | 7 |
| 06/03/91 | 1.75 | 0.40 | 0.223 | 0.100 | 0.056 | | 86 | | 412 | 1 | 1 | 1 | 1 | 0 | 0 | 4 | 7.59 | 7.45 | 21 | 25 | 14 | 11 |
| 06/04/91 | 1.78 | 0.40 | | 0.200 | | | | | | 0 | 0 | 1 | 1 | 0 | 0 | 2 | 7.28 | 7.30 | 22 | 24 | 8 | 9 |
| 06/05/91 | 1.79 | 0.37 | | 0.185 | | | | | | 0 | 0 | 1 | 1 | 0 | 0 | 2 | 7.44 | 7.23 | 21 | 22 | 10 | 13 |
| 06/06/91 | 1.77 | 0.30 | 0.318 | 0.075 | 0.080 | | | | 28 | 0 | 0 | 1 | 1 | 1 | 1 | 4 | 7.38 | 7.53 | 21 | 23 | 11 | 11 |
| 06/10/91 | 1.77 | 0.22 | 0.100 | 0.055 | 0.025 | | 25 | | 20 | 0 | 0 | 1 | 1 | 1 | 1 | 4 | 7.46 | 7.51 | 21 | 23 | 14 | 14 |
| 06/12/91 | 1.89 | 0.44 | | 0.220 | | | | | | 0 | 0 | 0 | 0 | 1 | 1 | 2 | 7.53 | 7.41 | 23 | 24 | 9 | 11 |
| 06/13/91 | 1.64 | 0.33 | | 0.165 | | | | | | 0 | 0 | 0 | 0 | 1 | 1 | 2 | 7.40 | 7.59 | 21 | 24 | 7 | 14 |
| 06/17/91 | 1.76 | 0.26 | 0.287 | 0.130 | 0.144 | | 70 | | 58 | 0 | 0 | 1 | 1 | 0 | 0 | 2 | 7.56 | 6.94 | 24 | 26 | 19 | 12 |
| 06/19/91 | 1.85 | 0.55 | | 0.275 | | | | | | 0 | 0 | 1 | 1 | 0 | 0 | 2 | 7.50 | 7.40 | 23 | 24 | 6 | 10 |
| 06/20/91 | 1.81 | 0.47 | | 0.235 | | | | | | 0 | 0 | 1 | 1 | 0 | 0 | 2 | 7.38 | 7.50 | 23 | 24 | 7 | 12 |
| 06/24/91 | 1.70 | 0.27 | 0.192 | 0.135 | 0.096 | | 74 | | 18 | 0 | 0 | 1 | 1 | 0 | 0 | 2 | 7.25 | 7.21 | 22 | 25 | 11 | 7 |
| 06/25/91 | 1.68 | 0.21 | | 0.105 | | | | | | 1 | 1 | 0 | 0 | 0 | 0 | 2 | 7.28 | 7.45 | 21 | 24 | 6 | 7 |
| 06/26/91 | 1.70 | 0.18 | | 0.090 | | | | | | 1 | 1 | 0 | 0 | 0 | 0 | 2 | 7.21 | 7.30 | 24 | 24 | 8 | 9 |
| 06/27/91 | 1.72 | 0.20 | | 0.100 | | | | | | 1 | 1 | 0 | 0 | 0 | 0 | 2 | 7.24 | 7.07 | 23 | 26 | 4 | 10 |
| 07/01/91 | 1.52 | 0.26 | 0.351 | 0.130 | 0.176 | | 3,300 | | 3,300 | 0 | 0 | 0 | 0 | 1 | 1 | 2 | 7.20 | 7.47 | 20 | 25 | 12 | 11 |
| 07/02/91 | 1.63 | 0.23 | 0.065 | 0.115 | 0.033 | | 14 | | | 0 | 0 | 0 | 0 | 1 | 1 | 2 | 7.20 | 7.08 | 24 | 26 | 5 | 8 |
| 07/04/91 | 1.34 | 0.22 | | 0.110 | | | | | | 0 | 0 | 0 | 0 | 1 | 1 | 2 | 7.01 | 7.06 | 22 | 23 | 9 | 6 |
| 07/09/91 | 1.48 | 0.08 | | 0.040 | | | 5 | | 2 | 1 | 1 | 0 | 0 | 0 | 0 | 2 | 7.17 | 7.17 | 24 | 24 | 8 | 12 |
| 07/10/91 | 1.50 | 0.04 | | 0.020 | | | 36 | | | 1 | 1 | 0 | 0 | 0 | 0 | 2 | 7.00 | 7.17 | 23 | 24 | 8 | 9 |
| 07/11/91 | 1.43 | 0.32 | | 0.160 | | | 15 | | | 1 | 1 | 0 | 0 | 0 | 0 | 2 | 7.07 | 7.22 | 24 | 25 | 10 | 11 |
| 07/15/91 | 1.45 | 0.47 | | 0.235 | | | 102 | | 38 | 1 | 1 | 0 | 0 | 0 | 0 | 2 | 7.34 | 7.20 | 23 | 25 | 9 | 10 |

**TABLE 3-2. NEW PROVIDENCE WASTEWATER TREATMENT PLANT
DAILY OPERATOR'S LOG DATA**

| DATE | FLOW (MGD) | | | | | FECAL COLIFORM | | ENTEROCOCCI ORGANISMS | | UV DISINFECTION | | | | | | | PLANT INFLUENT | | | | | |
|--|----------------------|----------------------|-------------------------|-------------------------|-------------------------|----------------------------|-------------------------|---------------------------|------------------------|--------------------|----|----|----|----|----|------------------------|----------------------|-----------------------|--------------------|--------------------|------------------|------------------|
| | TOTAL PLANT INF. | TOTAL PLANT EFF. | INSTANT. FLOW THRU UV | EFF FLOW PER UV BANK | INST. Q PER UV BANK | INFLUENT (Fecal/100 ml) | EFFLUENT (Fecal/100 ml) | INFLUENT (Ent./100 ml) | EFFLUENT (Ent./100 ml) | BANKS IN OPERATION | | | | | | TOTAL # OF BANKS OPER. | PH A.M. (S.U.) | PH P.M. (S.U.) | TEMP. A.M. (deg C) | TEMP. P.M. (deg C) | SET. SOLIDS A.M. | SET. SOLIDS P.M. |
| | | | | | | | | | | 1A | 1B | 2A | 2B | 3A | 3B | | | | | | | |
| 07/16/91 | 1.43 | 0.35 | | 0.175 | | | 52 | | 2 | 0 | 0 | 1 | 1 | 0 | 0 | 2 | 7.10 | 7.20 | 29 | 28 | 6 | 8 |
| 07/22/91 | 1.53 | 0.51 | | 0.255 | | | 36 | | 2 | 0 | 0 | 0 | 0 | 1 | 1 | 2 | 6.90 | 7.13 | 26 | 27 | 12 | 11 |
| 07/23/91 | 1.88 | 0.40 | | 0.200 | | | 12 | | | 0 | 0 | 0 | 0 | 1 | 1 | 2 | 7.17 | 6.98 | 25 | 28 | 11 | 10 |
| 07/24/91 | 1.77 | 0.40 | | 0.200 | | | | | | 0 | 0 | 0 | 0 | 1 | 1 | 2 | 7.06 | 7.30 | 25 | 25 | 17 | 8 |
| 07/25/91 | 1.80 | 0.45 | | 0.225 | | | | | | 0 | 0 | 0 | 0 | 1 | 1 | 2 | 7.13 | 7.34 | 25 | 25 | 11 | 9 |
| 07/29/91 | 1.79 | 0.32 | | 0.160 | | | 28 | | 2 | 0 | 0 | 0 | 0 | 1 | 1 | 2 | 7.26 | 7.48 | 24 | 28 | 9 | 10 |
| 07/31/91 | 1.72 | 0.35 | | 0.175 | | | 30 | | | 0 | 0 | 1 | 1 | 0 | 0 | 2 | 7.46 | 7.48 | 23 | 25 | 9 | 9 |
| 08/01/91 | 1.72 | 0.34 | | 0.170 | | | | | | 0 | 0 | 1 | 1 | 0 | 0 | 2 | 7.26 | 7.53 | 24 | 26 | 8 | 7 |
| 08/05/91 | 1.51 | 0.50 | | 0.250 | | | 56 | | 20 | 0 | 0 | 0 | 0 | 1 | 1 | 2 | 7.15 | 7.46 | 24 | 26 | 7 | 10 |
| 08/06/91 | 1.47 | 0.47 | | 0.235 | | | | | | 0 | 0 | 0 | 0 | 1 | 1 | 2 | 7.23 | 7.38 | 24 | 27 | 8 | 13 |
| 08/07/91 | 1.54 | 0.46 | | 0.230 | | | | | | 0 | 0 | 0 | 0 | 1 | 1 | 2 | 6.97 | 7.52 | 24 | 26 | 6 | 8 |
| 08/12/91 | 1.86 | 0.37 | | 0.185 | | | 176 | | 29 | 0 | 0 | 0 | 0 | 1 | 1 | 2 | 7.00 | 7.02 | 24 | 25 | 6 | 10 |
| 08/13/91 | 1.68 | 0.38 | | 0.190 | | | | | | 0 | 0 | 1 | 1 | 0 | 0 | 2 | 7.42 | 7.24 | 25 | 25 | 7 | 11 |
| 08/14/91 | 1.62 | 0.41 | | 0.205 | | | | | | 0 | 0 | 1 | 1 | 0 | 0 | 2 | 7.26 | 7.39 | 25 | 26 | 10 | 10 |
| 08/20/91 | 2.62 | 0.97 | | 0.243 | | | | | | 1 | 1 | 1 | 1 | 0 | 0 | 4 | 7.53 | 7.45 | 24 | 25 | 4 | 13 |
| 08/21/91 | 1.99 | 0.66 | | 0.165 | | | 20 | | 76 | 1 | 1 | 1 | 1 | 0 | 0 | 4 | 7.22 | 7.44 | 23 | 26 | 5 | 14 |
| 08/22/91 | 1.79 | 0.56 | | 0.280 | | | | | | 1 | 1 | 0 | 0 | 0 | 0 | 2 | 6.67 | 6.99 | 22 | 22 | 6 | 10 |
| 08/27/91 | 1.59 | 0.47 | | 0.235 | | | | | | 1 | 0 | 0 | 0 | 1 | 1 | 2 | 7.25 | 7.45 | 23 | 25 | 6 | 12 |
| 08/28/91 | 1.73 | 0.39 | | 0.195 | | | 18 | | 0 | 0 | 0 | 0 | 0 | 1 | 1 | 2 | 7.44 | 7.35 | 23 | 26 | 16 | 12 |
| 08/29/91 | 1.65 | 0.43 | | 0.215 | | | | | | 0 | 0 | 0 | 0 | 1 | 1 | 2 | 7.36 | 7.29 | 24 | 26 | 12 | 13 |
| DESIGN VALUE: -MAX. 30 DAY -MAX. 7 DAY | | 0.9 (1) 6.0 (2) | 0.9 (1) 6.0 (2) | 0.3 (1) 2.0 (2) | 0.3 (1) 2.0 (2) | | 200 400 | | 33 61 | | | | | | | | | | 10 Low 24 High | 10 Low 24 High | | |
| MINIMUM MAXIMUM AVERAGE | 1.32 5.26 2.07 | 0.04 3.27 0.80 | 0.065 3.768 0.827 | 0.020 1.635 0.213 | 0.025 0.942 0.273 | 22,600 70,000 46,533 | < 1 114,000 1,140 | 2,800 41,300 11,700 | 0 3,230 179 | | | | | | | 1 6 3 | 6.33 8.34 7.17 | 6.47 10.78 7.27 | 12 29 19 | 12 28 21 | 2 40 9 | 3 35 10 |

PAGE 112

**TABLE 3-2. NEW PROVIDENCE WASTEWATER TREATMENT PLANT
DAILY OPERATOR'S LOG DATA**

| DATE | PLANT EFFLUENT | | | | | | | | NH3 | | BOD | | | SUSPENDED SOLIDS | | | CBOD | | NBOD | | COMMENTS |
|----------|----------------------|----------------------|--------------------------|--------------------------|----------------------------------|----------------------------------|------------------------|------------------------|------|------|------|------|---------------------|------------------|------|---------------------|------|------|------|-------------|----------|
| | PH A.M. (S.U.) | PH P.M. (S.U.) | TEMP. A.M. (deg C) | TEMP. P.M. (deg C) | SET. SOLIDS A.M. (mg/l) | SET. SOLIDS P.M. (mg/l) | D.O. A.M. (mg/l) | D.O. P.M. (mg/l) | INF. | EFF. | INF. | EFF. | PER. REM. (%) | INF. | EFF. | PER. REM. (%) | INF. | EFF. | INF. | EFF. | |
| 07/03/89 | 6.37 | 6.82 | 22 | 24 | 0 | 0 | 7.9 | 8.0 | | | | | | | | | | | | | |
| 07/04/89 | 6.17 | 6.67 | 23 | 24 | 0 | 0 | 8.2 | 8.1 | | | | | | | | | 184 | 19 | 126 | 13 | |
| 07/05/89 | 6.27 | 6.54 | 22 | 23 | 0 | 0 | 8.0 | 8.2 | | | | | | | | | | | | | |
| 07/06/89 | 6.90 | 7.03 | 23 | 24 | 0 | 0 | 8.2 | 7.9 | | | 99 | 11 | 89 | 132 | 10 | 92 | | | | | |
| 07/10/89 | 6.58 | 6.85 | 23 | 23 | 0 | 0 | 7.7 | 7.7 | | | | | | | | | 200 | 22 | 121 | 15 | |
| 07/11/89 | 6.69 | 6.84 | 24 | 24 | 0 | 0 | 7.7 | 7.6 | | | 183 | 10 | 95 | 140 | 6 | 98 | | | | | |
| 07/12/89 | 6.67 | 6.80 | 22 | 25 | 0 | 0 | 8.0 | 8.1 | | | 143 | 9 | 94 | 120 | 10 | 92 | | | | | |
| 07/13/89 | 6.55 | 6.80 | 22 | 22 | 0 | 0 | 8.5 | 8.2 | | | 109 | 8 | 93 | 108 | 13 | 88 | | | | | |
| 07/17/89 | 7.03 | 6.82 | 20 | 23 | 0 | 0 | 8.1 | 8.0 | | | | | | | | | | | | | |
| 07/18/89 | 6.90 | 6.87 | 22 | 24 | 0 | 0 | 8.0 | 7.7 | | | | | | | | | 198 | 13 | | | |
| 07/19/89 | 6.49 | 7.34 | 22 | 24 | 0 | 0 | 7.9 | 7.7 | | | 125 | 6 | 95 | 108 | 2 | 98 | | | 100 | 12 | |
| 07/20/89 | 6.40 | 7.17 | 22 | 22 | 0 | 0 | 8.1 | 7.8 | | | 127 | 7 | 94 | 132 | 6 | 95 | | | | | |
| 07/24/89 | 6.87 | 6.68 | 24 | 25 | 0 | 0 | 8.3 | 7.3 | | | | | | | | | 191 | 20 | | | |
| 07/25/89 | 7.03 | 6.96 | 23 | 25 | 0 | 0 | 7.7 | 7.7 | | | 142 | 11 | 92 | 144 | 4 | 97 | | | 120 | 11 | |
| 07/26/89 | 6.81 | 7.03 | 24 | 25 | 0 | 0 | 7.5 | 7.7 | | | 135 | 11 | 92 | 184 | 3 | 97 | | | | | |
| 07/31/89 | 6.98 | 7.04 | 22 | 22 | 0 | 0 | 7.7 | 8.0 | | | | | | | | | | | | | |
| 08/02/89 | 7.49 | 7.08 | 22 | 24 | 0 | 0 | 8.3 | 7.9 | | | 146 | 9 | 94 | 172 | 5 | 97 | 219 | 20 | | | |
| 08/07/89 | 6.83 | 6.66 | 23 | 25 | 0 | 0 | 8.0 | 7.5 | | | | | | | | | | | | | |
| 08/08/89 | 6.94 | 7.30 | 22 | 24 | 0 | 0 | 7.7 | 7.7 | | | 179 | 13 | 93 | 100 | 11 | 89 | 255 | 25 | | | |
| 08/09/89 | 6.94 | 7.50 | 20 | 24 | 0 | 0 | 8.9 | 7.5 | | | 156 | 11 | 93 | 176 | 7 | 96 | | | | | |
| 08/10/89 | 7.02 | 7.62 | 21 | 24 | 0 | 0 | 7.9 | 7.2 | | | | | | 160 | 10 | 94 | | | | | |
| 08/14/89 | 6.57 | 7.41 | 23 | 24 | 0 | 0 | 6.4 | 7.3 | | | | | | | | | | | | | |
| 08/15/89 | 6.85 | 7.25 | 24 | 24 | 0 | 0 | 7.1 | 7.1 | | | | | | | | | 190 | 21 | | | |
| 08/16/89 | 7.01 | 6.92 | 24 | 24 | 0 | 0 | 7.0 | 7.1 | | | 137 | 12 | 91 | 92 | 8 | 92 | | | | | |
| 08/17/89 | 7.16 | 6.31 | 23 | 24 | 0 | 0 | 7.5 | 7.1 | | | 152 | 13 | 91 | 84 | 16 | 81 | | | | | |
| 08/22/89 | 7.31 | 7.45 | 22 | 25 | 0 | 0 | 7.3 | 7.8 | | | 99 | 9 | 91 | 140 | 7 | 95 | | | | | |
| 08/24/89 | 7.56 | 7.60 | 22 | 25 | 0 | 0 | 7.6 | 7.6 | | | | | | 122 | 8 | 93 | 278 | 18 | | | |
| 08/29/89 | | 7.18 | | 23 | | | | 7.9 | | | 94 | 10 | 89 | 102 | 10 | 90 | 107 | 17 | | | |
| 08/30/89 | 7.20 | 7.05 | 24 | 25 | 0 | 0 | 7.4 | 7.8 | | | | | | | | | | | | | |
| 09/01/89 | 7.12 | 7.35 | 22 | 24 | 0 | 0 | 7.5 | 7.7 | | | 113 | 11 | 90 | 97 | 5 | 95 | | | | | |
| 09/05/89 | 7.33 | 7.21 | 20 | 22 | 0 | 0 | 7.8 | 8.6 | | | | | | | | | 188 | 17 | | | |
| 09/06/89 | 7.00 | 7.16 | 20 | 23 | 0 | 0 | 7.9 | 8.1 | | | | | | | | | | | | | |
| 09/07/89 | 7.17 | 6.98 | 20 | 24 | 0 | 0 | 7.9 | 8.1 | | | 158 | 7 | 96 | 148 | 13 | 91 | | | | | |
| 09/11/89 | 6.92 | 6.95 | 23 | 25 | 0 | 0 | 7.9 | 7.7 | | | | | | | | | 215 | 18 | | | |
| 09/12/89 | 6.91 | 6.95 | 22 | 25 | 0 | 0 | 7.9 | 7.4 | | | | | | | | | | | | | |
| 09/13/89 | 6.86 | 7.51 | 22 | 24 | 0 | 0 | 7.7 | 7.6 | | | 258 | 13 | 95 | 166 | 5 | 97 | | | | | |
| 09/18/89 | 7.51 | 6.77 | 22 | 22 | 0 | 0 | 7.9 | 7.9 | | | 171 | 9 | 95 | 162 | 8 | 94 | | | | | |
| 09/20/89 | 6.82 | 7.19 | 23 | 24 | 0 | 0 | 8.5 | 8.2 | | | | | | | | | 97 | 25 | | | |
| 09/25/89 | 6.85 | 7.40 | 18 | 22 | 0 | 0 | 8.1 | 8.7 | | | | | | | | | 198 | 28 | | | |
| 09/26/89 | 7.03 | 7.17 | 21 | 22 | 0 | 0 | 7.7 | 8.2 | | | 119 | 16 | 87 | 114 | 16 | 86 | | | | See Note #3 | |
| 09/27/89 | 7.21 | 7.34 | 18 | 20 | 0 | 0 | 8.2 | 8.2 | | | | | | | | | | | | | |
| 09/28/89 | 6.80 | 7.33 | 18 | 20 | 0 | 0 | 8.2 | 8.7 | | | | | | | | | | | | | |
| 09/29/89 | 6.43 | 7.41 | 18 | 20 | 0 | 0 | 8.1 | 8.2 | | | | | | | | | | | | | |
| 10/02/89 | 6.70 | 7.19 | 21 | 22 | 0 | 0 | 8.0 | 7.6 | | | | | | | | | | | | See Note #3 | |
| 10/03/89 | 6.68 | 7.16 | 21 | 21 | 0 | 0 | 7.7 | 8.0 | | | | | | 110 | 11 | 90 | 130 | 24 | 114 | 50 | |
| 10/04/89 | 6.84 | 7.08 | 18 | 20 | 0 | 0 | 9.1 | 8.9 | | | | | | | | | | | | | |
| 10/05/89 | 7.33 | 7.45 | 18 | 20 | 0 | 0 | 9.1 | 8.8 | | | 127 | 11 | 91 | 140 | 15 | 89 | 175 | 25 | | | |
| 10/07/89 | 7.27 | 7.21 | 19 | 20 | 0 | 0 | 7.7 | 7.5 | | | | | | | | | | | | | |

PAGE 113

**TABLE 3-2. NEW PROVIDENCE WASTEWATER TREATMENT PLANT
DAILY OPERATOR'S LOG DATA**

| DATE | PLANT EFFLUENT | | | | | | | | NH3 | | BOD | | | SUSPENDED SOLIDS | | | CBOD | | NBOD | | COMMENTS |
|----------|----------------------|----------------------|--------------------------|--------------------------|----------------------------------|----------------------------------|------------------------|------------------------|------|------|------|------|---------------------|------------------|------|---------------------|------|------|------|------|----------|
| | PH A.M. (S.U.) | PH P.M. (S.U.) | TEMP. A.M. (deg C) | TEMP. P.M. (deg C) | SET. SOLIDS A.M. (mg/l) | SET. SOLIDS P.M. (mg/l) | D.O. A.M. (mg/l) | D.O. P.M. (mg/l) | INF. | EFF. | INF. | EFF. | PER. REM. (%) | INF. | EFF. | PER. REM. (%) | INF. | EFF. | INF. | EFF. | |
| 10/10/89 | 7.31 | 7.50 | 18 | 18 | 0 | 0 | 9.2 | 8.6 | | | 158 | 12 | 92 | 132 | 18 | 88 | 211 | 26 | | | |
| 10/11/89 | | | 19 | 19 | 0 | 0 | 8.6 | 8.6 | | | 158 | 12 | 92 | 192 | 13 | 93 | 223 | 23 | 174 | 78 | |
| 10/16/89 | 7.15 | 7.23 | 21 | 21 | 0 | 0 | 7.7 | 8.4 | | | | | | | | | | | | | |
| 10/17/89 | 8.98 | 7.11 | 22 | 23 | 0 | 0 | 7.7 | 8.0 | | | | | | | | | | | | | |
| 10/18/89 | 7.27 | 7.32 | 18 | 19 | 0 | 0 | 8.2 | 9.2 | | | 109 | 14 | 87 | 96 | 9 | 91 | 144 | 23 | 87 | 51 | |
| 10/19/89 | 7.37 | 7.53 | 16 | 17 | 0 | 0 | 9.5 | 9.6 | | | | | | | | | | | | | |
| 10/20/89 | 7.22 | 7.06 | 18 | 19 | 0 | 0 | 9.2 | 8.9 | | | | | | | | | | | | | |
| 10/24/89 | 7.18 | 7.84 | 18 | 20 | 0 | 0 | 8.7 | 9.5 | | | 145 | 19 | 87 | 188 | 19 | 90 | 267 | 28 | | | |
| 10/25/89 | 7.39 | 7.44 | 18 | 21 | 0 | 0 | 9.0 | 9.1 | | | | | | | | | 153 | 26 | 110 | 46 | |
| 10/26/89 | 7.09 | 7.31 | 18 | 21 | 0 | 0 | 8.7 | 9.3 | | | | | | | | | | | | | |
| 10/27/89 | 7.22 | 7.29 | 18 | 22 | 0 | 0 | 9.1 | 8.6 | | | | | | | | | | | | | |
| 10/30/89 | 7.09 | 7.29 | 19 | 22 | 0 | 0 | 8.8 | 8.8 | | | | | | | | | | | | | |
| 10/31/89 | 7.09 | 7.25 | 20 | 21 | 0 | 0 | 8.7 | 8.6 | | | | | | | | | | | | | |
| 11/01/89 | 7.12 | 7.43 | 19 | 21 | 0 | 0 | 9.1 | 9.8 | | | | | | 88 | 16 | 82 | 151 | 23 | | | |
| 11/02/89 | 7.29 | 7.50 | 18 | 19 | 0 | 0 | 9.5 | 9.2 | | | 122 | 11 | 91 | 87 | 9 | 90 | 111 | 18 | 69 | 18 | |
| 11/06/89 | 7.31 | 7.33 | 18 | 19 | 0 | 0 | 8.8 | 9.1 | | | | | | | | | | | | | |
| 11/07/89 | 7.33 | 7.21 | 19 | 19 | 0 | 0 | 9.1 | 9.1 | | | 157 | 13 | 92 | 128 | 11 | 91 | 181 | 22 | | | |
| 11/08/89 | 6.75 | 7.13 | 18 | 21 | 0 | 0 | 8.6 | 8.4 | | | 158 | 13 | 92 | 122 | 8 | 93 | | | 91 | 23 | |
| 11/13/89 | 6.82 | 7.41 | 17 | 19 | 0 | 0 | 9.5 | 9.5 | | | | | | | | | | | | | |
| 11/15/89 | 7.21 | 7.08 | 20 | 22 | 0 | 0 | 8.2 | 8.6 | | | 134 | 11 | 92 | 140 | 20 | 86 | 161 | 22 | 114 | 29 | |
| 11/16/89 | 6.97 | 7.48 | 22 | 20 | 0 | 0 | 8.2 | 8.4 | | | 137 | 10 | 92 | 116 | 17 | 84 | | | | | |
| 11/20/89 | 7.24 | 7.34 | 15 | 16 | 0 | 0 | 10.0 | 9.5 | | | | | | | | | | | | | |
| 11/21/89 | 7.32 | 7.29 | 16 | 15 | 0 | 0 | 9.6 | 9.9 | | | 146 | 12 | 92 | 116 | 11 | 91 | 217 | 24 | | | |
| 11/27/89 | 7.10 | 7.36 | 15 | 16 | 0 | 0 | 9.9 | 9.8 | | | | | | | | | | | | | |
| 11/28/89 | 6.85 | 7.40 | 17 | 18 | 0 | 0 | 9.6 | 9.5 | | | 135 | 8 | 94 | 158 | 9 | 94 | 189 | 20 | | | |
| 11/29/89 | 7.25 | 7.10 | 15 | 16 | 0 | 0 | 9.9 | 10.2 | | | 133 | 8 | 94 | 122 | 9 | 93 | | | 101 | 23 | |
| 11/30/89 | 7.32 | 7.20 | 14 | 16 | 0 | 0 | 10.6 | 10.2 | | | | | | 134 | 8 | 94 | | | | | |
| 12/04/89 | 7.07 | 7.21 | 12 | 11 | 0 | 0 | 11.4 | 11.5 | | | | | | | | | | | | | |
| 12/05/89 | 6.84 | 6.77 | 12 | 14 | 0 | 0 | 10.9 | 10.9 | 14 | 4.6 | 143 | 9 | 94 | 114 | 6 | 95 | 237 | 17 | 91 | 33 | |
| 12/06/89 | 7.11 | 6.98 | 14 | 15 | 0 | 0 | 10.6 | 10.6 | | | | | | 106 | 6 | 94 | 164 | 20 | | | |
| 12/11/89 | 7.69 | 7.15 | 14 | 14 | 0 | 0 | 10.8 | 10.9 | | | | | | | | | | | | | |
| 12/12/89 | 7.05 | 7.19 | 14 | 15 | 0 | 0 | 10.2 | 10.2 | | | | | | | | | | | | | |
| 12/13/89 | 7.01 | 7.21 | 14 | 15 | 0 | 0 | 10.8 | 11.0 | | | 4.3 | 157 | 10 | 94 | 142 | 12 | 92 | 219 | 25 | 110 | 31 |
| 12/13/89 | 7.01 | 7.21 | 14 | 15 | 0 | 0 | 10.8 | 11.0 | | | 174 | 16 | 91 | 134 | 14 | 90 | | | | | |
| 12/18/89 | 7.07 | 7.20 | 11 | 14 | 0 | 0 | 11.2 | 11.0 | | | | | | | | | | | | | |
| 12/20/89 | 7.12 | 7.33 | 12 | 12 | 0 | 0 | 11.1 | 10.9 | | | | | | 118 | 11 | 91 | 194 | 26 | 137 | 35 | |
| 12/21/89 | 7.04 | 7.33 | 11 | 13 | 0 | 0 | 10.8 | 11.3 | 24 | 5.2 | 185 | 13 | 93 | 114 | 15 | 87 | 250 | 24 | | | |
| 12/26/89 | 7.29 | 7.34 | 9 | 10 | 0 | 0 | 10.5 | 10.1 | | | | | | | | | | | | | |
| 12/27/89 | 7.21 | 7.51 | 8 | 8 | 0 | 0 | 10.7 | 11.1 | 17 | 6.1 | 192 | 13 | 93 | 188 | 11 | 94 | 205 | 29 | 146 | 37 | |
| 01/02/90 | 7.12 | 7.29 | 12 | 14 | 0 | 0 | 10.6 | 10.9 | | | | | | | | | | | | | |
| 01/03/90 | 7.11 | 7.30 | 13 | 15 | 0 | 0 | 10.5 | 10.1 | 20 | 2.8 | 165 | 15 | 91 | 218 | 11 | 95 | 246 | 30 | 133 | 40 | |
| 01/04/90 | 7.05 | 7.14 | 15 | 13 | 0 | 0 | 10.2 | 10.5 | | | 166 | 12 | 93 | 210 | 11 | 95 | 279 | 25 | | | |
| 01/07/90 | 7.10 | 7.20 | 11 | 11 | 0 | 0 | 9.3 | 9.3 | | | | | | | | | | | | | |
| 01/08/90 | 7.06 | 7.22 | 14 | 14 | 0 | 0 | 10.4 | 11.0 | | | | | | | | | | | | | |
| 01/09/90 | 7.05 | 7.19 | 14 | 15 | 0 | 0 | 10.2 | 10.2 | 20 | 9.8 | 176 | 14 | 92 | 148 | 12 | 92 | 213 | 33 | 169 | 63 | |
| 01/10/90 | 7.12 | 7.32 | 14 | 17 | 0 | 0 | 11.2 | 10.5 | | | | | | 114 | 21 | 82 | | | | | |
| 01/11/90 | 7.16 | 7.38 | 14 | 15 | 0 | 0 | 10.4 | 11.1 | | | 135 | 15 | 89 | 128 | 14 | 89 | 213 | 28 | | | |
| 01/15/90 | 6.81 | 7.16 | 13 | 15 | 0 | 0 | 11.1 | 11.5 | | | | | | | | | | | | | |
| 01/16/90 | 7.11 | 7.16 | 14 | 16 | 0 | 0 | 10.5 | 10.5 | 18 | 6.6 | 189 | 15 | 92 | 228 | 19 | 92 | 272 | 28 | 122 | 51 | |

**TABLE 3-2. NEW PROVIDENCE WASTEWATER TREATMENT PLANT
DAILY OPERATOR'S LOG DATA**

| DATE | PLANT EFFLUENT | | | | | | | | NH3 | | BOD | | | SUSPENDED SOLIDS | | | CBOD | | NBOD | | COMMENTS |
|----------|----------------------|----------------------|--------------------------|--------------------------|----------------------------------|----------------------------------|------------------------|------------------------|------|------|------|------|---------------------|------------------|------|---------------------|------|------|------|------|-------------|
| | PH A.M. (S.U.) | PH P.M. (S.U.) | TEMP. A.M. (deg C) | TEMP. P.M. (deg C) | SET. SOLIDS A.M. (mg/l) | SET. SOLIDS P.M. (mg/l) | D.O. A.M. (mg/l) | D.O. P.M. (mg/l) | INF. | EFF. | INF. | EFF. | PER. REM. (%) | INF. | EFF. | PER. REM. (%) | INF. | EFF. | INF. | EFF. | |
| 01/17/90 | 7.14 | 7.13 | 15 | 15 | 0 | 0 | 9.9 | 10.2 | | | 148 | 13 | 91 | 172 | 15 | 92 | | | | | |
| 01/18/90 | 7.06 | 7.51 | 16 | 18 | 0 | 0 | 9.9 | 9.7 | | | 140 | 16 | 89 | 100 | 16 | 84 | 193 | 31 | | | |
| 01/22/90 | 7.16 | 7.22 | 13 | 14 | 0 | 0 | 10.6 | 11.1 | | | | | | | | | | | | | |
| 01/23/90 | 7.19 | 7.23 | 13 | 15 | 0 | 0 | 10.5 | 11.0 | 14 | 6.8 | 142 | 13 | 91 | 158 | 19 | 88 | 243 | 28 | 95 | 47 | |
| 01/24/90 | 7.17 | 7.10 | 14 | 15 | 0 | 0 | 10.2 | 10.9 | | | | | | | | | 221 | 35 | | | |
| 01/28/90 | 6.81 | 7.44 | 13 | 14 | 0 | 0 | 10.7 | 11.6 | | | | | | | | | | | | | |
| 01/30/90 | 7.12 | 7.21 | 13 | 15 | 0 | 0 | 12.2 | 11.5 | 7 | 4.5 | 77 | 25 | 68 | 82 | 31 | 82 | | | 85 | 32 | |
| 01/31/90 | 7.11 | 7.28 | 14 | 15 | 0 | 0 | 11.4 | 11.7 | | | 89 | 18 | 90 | 108 | 17 | 84 | 161 | 33 | | | |
| 02/01/90 | 7.14 | 7.38 | 14 | 17 | 0 | 0 | 11.4 | 10.6 | | | | | | | | | | | | | |
| 02/05/90 | 7.18 | 7.39 | 13 | 17 | 0 | 0 | 11.2 | 11.3 | | | | | | | | | | | | | |
| 02/06/90 | 7.26 | 7.35 | 12 | 15 | 0 | 0 | 10.0 | 11.0 | 12 | 8.6 | 145 | 17 | 88 | 170 | 16 | 91 | 194 | 34 | | | |
| 02/07/90 | 7.27 | 7.22 | 17 | 17 | 0 | 0 | 10.8 | 11.1 | | | 120 | 12 | 90 | 158 | 9 | 94 | 204 | 27 | | | |
| 02/13/90 | 7.16 | 7.64 | 15 | 17 | 0 | 0 | 9.8 | 11.1 | 13.3 | 7.3 | 144 | 18 | 88 | 156 | 22 | 86 | 209 | 34 | | | |
| 02/14/90 | 7.10 | 7.20 | 18 | 18 | 0 | 0 | 9.9 | 10.7 | | | 128 | 13 | 90 | 142 | 13 | 91 | | | | | |
| 02/15/90 | 6.86 | 7.15 | 14 | 14 | 0 | 0 | 10.3 | 10.9 | | | 177 | 15 | 92 | 176 | 12 | 93 | 246 | 31 | | | |
| 02/20/90 | 6.90 | 7.19 | 12 | 11 | 0 | 0 | 11.2 | 11.2 | 10.1 | 3.5 | 198 | 15 | 92 | 268 | 14 | 95 | 232 | 28 | | | |
| 02/21/90 | 7.09 | 7.01 | 13 | 13 | 0 | 0 | 11.2 | 11.7 | | | 178 | 14 | 92 | 182 | 11 | 94 | 253 | 27 | | | |
| 02/26/90 | 7.32 | 7.45 | 10 | 11 | 0 | 0 | 12.9 | 12.3 | | | | | | | | | | | | | |
| 02/27/90 | 7.14 | 7.26 | 13 | 13 | 0 | 0 | 11.0 | 12.4 | 16.2 | 6.3 | 137 | 12 | 91 | 158 | 15 | 91 | 210 | 27 | | | |
| 02/28/90 | 7.27 | 7.53 | 11 | 15 | 0 | 0 | 11.3 | 10.9 | | | 181 | 13 | 93 | 134 | 7 | 95 | 203 | 32 | | | |
| 03/05/90 | 6.88 | 7.15 | 12 | 13 | 0 | 0 | 11.7 | 12.2 | | | | | | | | | | | | | |
| 03/06/90 | 6.91 | 7.03 | 13 | 11 | 0 | 0 | 10.9 | 11.8 | 19.5 | 3.1 | 209 | 15 | 93 | 338 | 11 | 97 | | | 99 | 29 | |
| 03/08/90 | 7.29 | 7.13 | 11 | 15 | 0 | 0 | 12.3 | 11.6 | | | 160 | 14 | 91 | 134 | 13 | 90 | 293 | 33 | | | |
| 03/12/90 | 7.25 | 6.88 | 16 | 18 | 0 | 0 | 10.5 | 9.8 | | | | | | | | | | | | | |
| 03/14/90 | 6.99 | 7.27 | 18 | 18 | 0 | 0 | 8.6 | 9.7 | | | 176 | 10 | 94 | 208 | 7 | 97 | 318 | 30 | | | |
| 03/15/90 | 6.54 | 7.09 | 16 | 19 | 0 | 0 | 10.1 | 10.1 | 18.4 | 2.6 | 174 | 13 | 93 | 208 | 14 | 93 | | | 155 | 40 | |
| 03/18/90 | 6.96 | 7.23 | 16 | 18 | 0 | 0 | 11.3 | 11.4 | | | | | | | | | | | | | |
| 03/20/90 | 6.84 | 7.08 | 16 | 14 | 0 | 0 | 9.4 | 11.4 | 23 | 14 | 190 | 19 | 90 | 1328 | 22 | 98 | 237 | 47 | 119 | 85 | |
| 03/22/90 | 7.15 | 7.26 | 16 | 17 | 0 | 0 | 11.4 | 10.7 | | | 112 | 17 | 85 | 242 | 7 | 97 | 338 | 32 | | | |
| 03/25/90 | 7.04 | 7.33 | 14 | 16 | 0 | 0 | 11.2 | 10.4 | | | | | | | | | | | | | |
| 03/27/90 | 7.08 | 7.06 | 13 | 14 | 0 | 0 | 10.5 | 11.6 | | | 150 | 17 | 89 | 136 | 5 | 96 | 211 | 28 | | | |
| 03/28/90 | 6.93 | 7.00 | 15 | 15 | 0 | 0 | 11.3 | 11.3 | 17.1 | 4.3 | 177 | 11 | 94 | 168 | 8 | 95 | 253 | 28 | 158 | 49 | |
| 03/29/90 | 7.02 | 7.39 | 14 | 18 | 0 | 0 | 10.8 | 11.0 | | | | | | | | | 204 | 20 | | | |
| 04/02/90 | 6.95 | 6.92 | 18 | 15 | 0 | 0 | 9.1 | 8.9 | | | | | | | | | | | | | |
| 04/03/90 | 6.81 | 7.06 | 14 | 14 | 0 | 0 | 9.0 | 9.1 | 7.7 | 2.6 | | | | 88 | 24 | 73 | 123 | 41 | 68 | 46 | See Note #3 |
| 04/04/90 | 6.93 | 7.21 | 15 | 14 | 0 | 0 | 9.2 | 9.2 | | | | | | 118 | 13 | 89 | 148 | 25 | | | |
| 04/05/90 | 6.96 | 7.22 | 14 | 17 | 0 | 0 | 9.1 | 9.3 | | | 102 | 15 | 85 | 90 | 9 | 90 | 174 | 28 | | | |
| 04/06/90 | 6.89 | 6.93 | 15 | 15 | 0 | 0 | 8.7 | 9.2 | | | | | | | | | | | | | |
| 04/09/90 | 6.95 | 7.14 | 14 | 16 | 0 | 0 | 9.2 | 8.9 | | | | | | | | | | | | | |
| 04/10/90 | 6.95 | 7.42 | 16 | 16 | 0 | 0 | 8.3 | 8.7 | 14.1 | 5.5 | 152 | 17 | 89 | 128 | 9 | 93 | 219 | 28 | 77 | 47 | |
| 04/11/90 | 6.87 | 7.00 | 16 | 17 | 0 | 0 | 8.3 | 8.5 | | | 120 | 15 | 88 | 96 | 9 | 91 | 161 | 23 | | | |
| 04/16/90 | 6.96 | 6.95 | 16 | 17 | 0 | 0 | 8.8 | 9.0 | | | | | | | | | | | | | |
| 04/17/90 | 6.75 | 7.20 | 16 | 17 | 0 | 0 | 8.3 | 9.0 | | | 116 | 15 | 87 | 106 | 14 | 87 | 279 | 24 | | | |
| 04/18/90 | 6.61 | 7.05 | 15 | 17 | 0 | 0 | 8.3 | 8.9 | 13.4 | 5.4 | 134 | 13 | 90 | 140 | 10 | 93 | 153 | 23 | 92 | 36 | |
| 04/19/90 | 6.82 | 6.99 | 16 | 18 | 0 | 0 | 8.5 | 8.8 | | | 128 | 10 | 92 | 120 | 8 | 93 | | | | | |
| 04/23/90 | 6.83 | 7.03 | 16 | 20 | 0 | 0 | 8.2 | 8.1 | | | | | | | | | | | | | |
| 04/24/90 | 6.64 | 7.54 | 17 | 19 | 0 | 0 | 7.6 | 8.2 | 8.4 | 1.9 | 185 | 12 | 94 | 174 | 11 | 94 | 226 | 23 | 143 | 37 | |
| 04/25/90 | 6.87 | 7.03 | 18 | 18 | 0 | 0 | 7.5 | 8.2 | | | | | | | | | 180 | 22 | | | |

**TABLE 3-2. NEW PROVIDENCE WASTEWATER TREATMENT PLANT
DAILY OPERATOR'S LOG DATA**

| DATE | PLANT EFFLUENT | | | | | | | | NH3 | | BOD | | | SUSPENDED SOLIDS | | | CBOD | | NBOD | | COMMENTS |
|----------|----------------------|----------------------|-------------------------|--------------------------|----------------------------------|----------------------------------|------------------------|------------------------|------|------|------|------|---------------------|------------------|------|---------------------|------|------|------|------|-------------|
| | PH A.M. (S.U.) | PH P.M. (S.U.) | TEMP A.M. (deg C) | TEMP. P.M. (deg C) | SET. SOLIDS A.M. (mg/l) | SET. SOLIDS P.M. (mg/l) | D.O. A.M. (mg/l) | D.O. P.M. (mg/l) | INF. | EFF. | INF. | EFF. | PER. REM. (%) | INF. | EFF. | PER. REM. (%) | INF. | EFF. | INF. | EFF. | |
| 04/26/90 | 6.71 | 7.33 | 18 | 20 | 0 | 0 | 7.6 | 8.2 | | | 149 | 8 | 95 | 114 | 8 | 93 | 180 | 15 | | | |
| 04/27/90 | 6.73 | 7.00 | 19 | 23 | 0 | 0 | 7.9 | 7.6 | | | | | | | | | | | | | |
| 04/28/90 | 6.97 | 6.96 | 20 | 20 | 0 | 0 | 7.6 | 7.6 | | | | | | | | | | | | | |
| 04/29/90 | 7.05 | 6.71 | 17 | 17 | 0 | 0 | 8.2 | 7.8 | | | | | | | | | | | | | |
| 04/30/90 | 6.74 | 7.00 | 18 | 18 | 0 | 0 | 8.2 | 8.3 | | | | | | | | | | | | | |
| 05/01/90 | 7.15 | 7.07 | 19 | 21 | 0 | 0 | 8.3 | 7.7 | 16 | 5.9 | 139 | 11 | 92 | 142 | 9 | 94 | 193 | 20 | 99 | 27 | |
| 05/02/90 | 6.74 | 6.88 | 19 | 20 | 0 | 0 | 7.9 | 8.0 | | | 164 | 8 | 95 | 142 | 3 | 98 | 199 | 16 | | | |
| 05/03/90 | 6.73 | 7.07 | 18 | 20 | 0 | 0 | 8.8 | 8.6 | | | 179 | 10 | 94 | 138 | 9 | 93 | 239 | 17 | | | |
| 05/07/90 | 6.86 | 7.05 | 18 | 20 | 0 | 0 | 7.7 | 8.1 | | | | | | | | | | | | | |
| 05/08/90 | 6.97 | 7.12 | 16 | 22 | 0 | 0 | 7.8 | 7.3 | 18 | 1.6 | 149 | 7 | 95 | 108 | 11 | 90 | 218 | 15 | 92 | 15 | |
| 05/14/90 | 6.87 | 7.06 | 18 | 20 | 0 | 0 | 8.2 | 8.2 | | | | | | | | | | | | | |
| 05/15/90 | 6.78 | 7.16 | 18 | 22 | 0 | 0 | 7.6 | 8.1 | 11 | 3.7 | 126 | 10 | 92 | 104 | 5 | 95 | 135 | 15 | 116 | 41 | |
| 05/22/90 | 7.15 | 7.26 | 19 | 19 | 0 | 0 | 7.5 | 7.9 | | | | | | | | | | | | | |
| 05/23/90 | 7.02 | 6.96 | 18 | 20 | 0 | 0 | 7.8 | 8.2 | 12 | 3.2 | 124 | 10 | 92 | 124 | 12 | 90 | 187 | 19 | 84 | 33 | |
| 05/24/90 | 6.76 | 6.88 | 19 | 20 | 0 | 0 | 7.4 | 7.9 | | | 132 | 9 | 93 | 108 | 7 | 94 | | | | | |
| 05/28/90 | 6.43 | 6.79 | 19 | 19 | 0 | 0 | 7.8 | 8.4 | 9 | 2 | 128 | 20 | 84 | 120 | 20 | 83 | 187 | 32 | 86 | 30 | |
| 05/31/90 | 6.41 | 7.34 | 19 | 20 | 0 | 0 | 8.8 | 8.8 | | | 92 | 14 | 85 | 92 | 16 | 83 | 130 | 24 | | | |
| 06/04/90 | 6.66 | 7.12 | 22 | 21 | 0 | 0 | 7.5 | 8.3 | | | | | | | | | | | | | |
| 06/05/90 | 6.73 | 7.15 | 19 | 20 | 0 | 0 | 7.9 | 8.0 | 15 | 1.9 | | | | | | | | | | | |
| 06/07/90 | 6.45 | 7.51 | 22 | 23 | 0 | 0 | 7.2 | 8.5 | | | 139 | 10 | 93 | 146 | 9 | 94 | 199 | 22 | 127 | 32 | |
| 06/11/90 | 6.84 | 6.89 | 20 | 22 | 0 | 0 | 7.6 | 7.9 | | | | | | | | | | | | | |
| 06/12/90 | 6.72 | 6.87 | 19 | 23 | 0 | 0 | 8.0 | 7.6 | 16 | 3.6 | 130 | 11 | 92 | 162 | 13 | 92 | 254 | 26 | 118 | 34 | |
| 06/13/90 | 6.76 | 7.27 | 20 | 24 | 0 | 0 | 7.9 | 7.4 | | | 130 | 9 | 93 | 158 | 8 | 95 | | | | | |
| 06/14/90 | 6.69 | 7.04 | 21 | 23 | 0 | 0 | 8.0 | 7.6 | | | | | | | | | 211 | 20 | | | |
| 06/16/90 | 6.82 | 7.09 | 22 | 24 | 0 | 0 | 7.5 | 7.5 | 11 | 2.1 | 158 | 19 | 88 | 194 | 11 | 94 | 221 | 32 | 93 | 27 | |
| 06/25/90 | 6.96 | 7.93 | 20 | 23 | 0 | 0 | 7.0 | 6.9 | | | | | | | | | | | | | |
| 06/26/90 | 7.04 | 7.54 | 20 | 23 | 0 | 0 | 7.3 | 6.7 | | | 136 | 19 | 86 | 151 | 1 | 99 | | | | | |
| 06/27/90 | 7.12 | 7.23 | 22 | 24 | 0 | 0 | 6.7 | 6.7 | | | 171 | 11 | 94 | 97 | 10 | 90 | 255 | 26 | | | |
| 07/04/90 | 7.03 | 7.09 | 22 | 24 | 0 | 0 | 6.0 | 6.1 | 14 | 0.4 | 160 | 13 | 92 | 128 | 14 | 89 | 189 | 24 | 101 | 11 | |
| 07/05/90 | 6.57 | 6.78 | 25 | 27 | 0 | 0 | 6.5 | 6.8 | | | 139 | 10 | 93 | 154 | 5 | 97 | 193 | 18 | | | |
| 07/06/90 | 6.23 | 7.07 | 24 | 26 | 0 | 0 | 7.6 | 7.0 | | | | | | | | | | | | | |
| 07/07/90 | 7.24 | 6.74 | 22 | 23 | 0 | 0 | 7.4 | 7.3 | | | | | | | | | | | | | |
| 07/08/90 | 6.58 | 6.73 | 21 | 23 | 0 | 0 | 7.1 | 6.8 | | | | | | | | | | | | | |
| 07/09/90 | 7.59 | 6.74 | 23 | 26 | 0 | 0 | 7.1 | 6.6 | | | | | | | | | | | | | |
| 07/10/90 | 6.50 | 7.10 | 24 | 25 | 0 | 0 | 6.1 | 6.7 | 19 | 0.8 | | | | 214 | 13 | 94 | | | 112 | 13 | |
| 07/12/90 | 7.57 | 7.06 | 22 | 23 | 0 | 0 | 7.8 | 7.2 | | | 155 | 7 | 95 | 124 | 7 | 94 | 184 | 14 | | | |
| 07/16/90 | 6.45 | 6.53 | 24 | 26 | 0 | 0 | 6.7 | 6.9 | | | | | | | | | | | | | |
| 07/17/90 | 7.06 | 7.05 | 24 | 25 | 0 | 0 | 7.1 | 6.6 | 13 | 6.4 | 129 | 7 | 95 | 126 | 9 | 93 | 193 | 17 | 176 | 75 | |
| 07/18/90 | 6.35 | 6.74 | 23 | 26 | 0 | 0 | 6.1 | 6.9 | | | 138 | 9 | 93 | 142 | 7 | 95 | 176 | 20 | | | |
| 07/19/90 | 6.40 | 6.69 | 24 | 27 | 0 | 0 | 6.9 | 6.7 | | | 136 | 7 | 94 | 178 | 8 | 98 | | | | | |
| 07/23/90 | 7.43 | 6.97 | 24 | 25 | 0 | 0 | 6.7 | 6.7 | | | | | | | | | | | | | See Note #3 |
| 07/25/90 | 6.72 | 6.86 | 25 | 27 | 0 | 0 | 6.3 | 6.3 | 12 | 1.4 | 138 | 8 | 94 | 122 | 10 | 92 | 226 | 24 | 57 | 6 | |
| 07/30/90 | 6.62 | 6.50 | 23 | 25 | 0 | 0 | 6.9 | 6.6 | | | | | | | | | | | | | |
| 07/31/90 | 6.91 | 6.81 | 24 | 26 | 0 | 0 | 6.7 | 6.5 | | | | | | | | | | | | | |
| 08/02/90 | 6.92 | 7.24 | 21 | 25 | 0 | 0 | 6.5 | 6.2 | 4.1 | 2.9 | 137 | 9 | 94 | 164 | 10 | 95 | 171 | 20 | | | |
| 08/06/90 | 6.71 | 7.05 | 24 | 25 | 0 | 0 | 7.9 | 7.2 | | | | | | | | | | | | | |
| 08/07/90 | 6.62 | 7.17 | 24 | 25 | 0 | 0 | 7.0 | 7.1 | 11 | 2.1 | 90 | 11 | 88 | 126 | 12 | 90 | 131 | 21 | 207 | 14 | |
| 08/09/90 | 6.66 | 6.87 | 24 | 25 | 0 | 0 | 7.5 | 6.9 | | | 117 | 9 | 92 | 132 | 16 | 88 | | | 427 | 26 | |

**TABLE 3-2. NEW PROVIDENCE WASTEWATER TREATMENT PLANT
DAILY OPERATOR'S LOG DATA**

| DATE | PLANT EFFLUENT | | | | | | | | NH3 | | BOD | | | SUSPENDED SOLIDS | | | CBOD | | NBOD | | COMMENTS |
|----------|---------------------|---------------------|--------------------------|--------------------------|----------------------------------|----------------------------------|------------------------|------------------------|------|------|------|------|---------------------|------------------|------|---------------------|------|------|------|------|-------------|
| | PH A.M. (S.U) | PH P.M. (S.U) | TEMP. A.M. (deg C) | TEMP. P.M. (deg C) | SET. SOLIDS A.M. (mg/l) | SET. SOLIDS P.M. (mg/l) | D.O. A.M. (mg/l) | D.O. P.M. (mg/l) | INF. | EFF. | INF. | EFF. | PER. REM. (%) | INF. | EFF. | PER. REM. (%) | INF. | EFF. | INF. | EFF. | |
| 08/13/90 | 6.63 | 7.28 | 24 | 25 | 0 | 0 | 7.3 | 6.7 | | | | | | | | | | | | | |
| 08/14/90 | 6.97 | 7.09 | 24 | 26 | 0 | 0 | 7.3 | 6.9 | 8 | 1.8 | 120 | 13 | 89 | 98 | 13 | 86 | 186 | 31 | 229 | 8 | |
| 08/15/90 | 6.70 | 7.06 | 24 | 25 | 0 | 0 | 6.4 | 7.3 | | | 157 | 13 | 92 | 78 | 7 | 91 | | | | | |
| 08/20/90 | 6.65 | 7.32 | 21 | 22 | 0 | 0 | 8.0 | 7.5 | | | | | | | | | | | | | |
| 08/21/90 | 7.13 | 7.23 | 21 | 22 | 0 | 0 | 7.7 | 7.5 | 16 | 0.8 | 136 | 11 | 92 | 100 | 15 | 85 | | | | | |
| 08/22/90 | 6.57 | 6.98 | 23 | 25 | 0 | 0 | 7.7 | 7.0 | | | | | | | | | 198 | 22 | | | |
| 08/23/90 | 7.42 | 7.28 | 23 | 24 | 0 | 0 | 7.0 | 7.0 | | | | | | 140 | 17 | 88 | 166 | 19 | 264 | 12 | |
| 08/27/90 | 6.68 | 6.96 | 24 | 26 | 0 | 0 | 7.4 | 7.2 | | | | | | | | | | | | | |
| 08/29/90 | 6.65 | 7.10 | 24 | 25 | 0 | 0 | 7.0 | 7.3 | 10 | 1.6 | 103 | 9 | 91 | 90 | 18 | 80 | 153 | 21 | 107 | 21 | |
| 08/30/90 | 6.87 | 7.04 | 23 | 24 | 0 | 0 | 6.0 | 7.4 | | | | | | 116 | 15 | 87 | 168 | 25 | 84 | 18 | |
| 09/04/90 | 6.72 | 7.30 | 22 | 24 | 0 | 0 | 6.7 | 6.0 | 21 | 1.7 | 138 | 13 | 91 | 210 | 17 | 92 | 203 | 23 | 297 | 21 | See Note #3 |
| 09/05/90 | 6.89 | 7.15 | 22 | 25 | 0 | 0 | 6.2 | 6.7 | | | | | | | | | | | | | |
| 09/06/90 | 6.95 | 7.15 | 24 | 25 | 0 | 0 | 7.0 | 6.9 | | | | | | | | | | | | | |
| 09/11/90 | 7.01 | 7.11 | 24 | 27 | 0 | 0 | 7.3 | 6.7 | | | | | | | | | | | | | |
| 09/12/90 | 6.75 | 7.10 | 25 | 25 | 0 | 0 | 7.2 | 6.5 | 19 | 0.2 | | | | 122 | 15 | 88 | 199 | 26 | 241 | 29 | |
| 09/13/90 | 7.11 | 7.45 | 25 | 25 | 0 | 0 | 5.6 | 7.4 | | | 122 | 9 | 93 | 124 | 13 | 90 | 206 | 15 | 264 | 19 | |
| 09/17/90 | 7.29 | 7.20 | 22 | 24 | 0 | 0 | 7.2 | 8.0 | | | | | | | | | | | | | |
| 09/19/90 | 6.68 | 7.18 | 20 | 22 | 0 | 0 | 5.1 | 5.6 | 20 | 4.2 | 146 | 22 | 85 | 140 | 13 | 91 | 250 | 38 | 300 | 30 | |
| 09/20/90 | 6.54 | 7.16 | 21 | 24 | 0 | 0 | 7.7 | 7.6 | | | | | | | | | 200 | 23 | | | |
| 09/24/90 | 6.95 | 7.27 | 20 | 21 | 0 | 0 | 7.9 | 8.0 | | | | | | | | | | | | | |
| 09/25/90 | 6.02 | 7.14 | 20 | 23 | 0 | 0 | 8.0 | 7.5 | 23 | 4.9 | 189 | 10 | 95 | 70 | 7 | 90 | 323 | 26 | 407 | 12 | |
| 09/26/90 | 7.26 | 7.19 | 21 | 23 | 0 | 0 | 7.0 | 7.3 | | | 157 | 10 | 94 | 202 | 10 | 95 | | | | | |
| 09/27/90 | 6.63 | 7.10 | 20 | 24 | 0 | 0 | 7.4 | 8.6 | | | | | | 218 | 7 | 97 | | | | | |
| 10/01/90 | 6.68 | 7.16 | 21 | 23 | 0 | 0 | 7.8 | 7.8 | | | | | | | | | | | | | |
| 10/03/90 | 6.67 | 6.67 | 20 | 22 | 0 | 0 | 8.0 | 7.3 | 14 | 2.1 | 176 | 10 | 94 | 202 | 12 | 94 | 216 | 19 | 59 | 20 | |
| 10/04/90 | 6.58 | 7.48 | 21 | 25 | 0 | 0 | 8.1 | 7.0 | | | 211 | 11 | 95 | 156 | 7 | 96 | 267 | 25 | 423 | 25 | |
| 10/09/90 | 7.14 | 7.20 | 25 | 25 | 0 | 0 | 7.3 | 7.3 | 14 | 3.8 | | | | 150 | 16 | 89 | 170 | 23 | 128 | 24 | |
| 10/10/90 | 6.44 | 6.86 | 23 | 25 | 0 | 0 | 6.4 | 7.4 | | | | | | 152 | 19 | 88 | | | | | |
| 10/11/90 | 6.63 | 7.23 | 23 | 25 | 0 | 0 | 7.5 | 7.3 | | | 134 | 11 | 92 | 496 | 8 | 98 | | | | | |
| 10/15/90 | 6.76 | 6.72 | 22 | 24 | 0 | 0 | 7.7 | 7.3 | | | | | | | | | | | | | |
| 10/16/90 | 7.12 | 7.07 | 22 | 22 | 0 | 0 | 8.0 | 7.8 | 18 | 5.3 | | | | 140 | 9 | 94 | 199 | 24 | 311 | 21 | |
| 10/17/90 | 6.82 | 7.03 | 21 | 23 | 0 | 0 | 6.9 | 8.0 | | | 161 | 11 | 93 | 420 | 7 | 98 | 179 | 22 | 381 | 32 | |
| 10/18/90 | 6.86 | 6.74 | 22 | 24 | 0 | 0 | 8.1 | 7.9 | | | | | | | | | 156 | 25 | | | |
| 10/22/90 | 6.91 | 7.02 | 20 | 23 | 0 | 0 | 8.0 | 7.8 | | | | | | | | | | | | | |
| 10/23/90 | 6.80 | 7.06 | 21 | 23 | 0 | 0 | 7.9 | 8.1 | 13 | 5.4 | 126 | 20 | 84 | 154 | 15 | 90 | | | | | |
| 10/25/90 | 6.83 | 6.92 | 19 | 20 | 0 | 0 | 7.9 | 8.9 | | | 122 | 12 | 90 | 112 | 8 | 93 | 179 | 24 | 256 | 30 | |
| 10/30/90 | 6.59 | 7.13 | 17 | 20 | 0 | 0 | 9.0 | 8.3 | | | 152 | 14 | 91 | 186 | 11 | 94 | 206 | 21 | 364 | 27 | |
| 11/05/90 | 6.91 | 6.53 | 20 | 21 | 0 | 0 | 8.1 | 7.5 | | | | | | | | | | | | | |
| 11/06/90 | 6.68 | 7.21 | 20 | 20 | 0 | 0 | 8.2 | 7.5 | 18 | 4.1 | 153 | 10 | 93 | 340 | 10 | 97 | 217 | 27 | 63 | 22 | |
| 11/07/90 | 6.53 | 6.55 | 18 | 20 | 0 | 0 | 7.9 | 8.4 | | | 148 | 10 | 93 | 126 | 7 | 94 | | | | | |
| 11/13/90 | 6.63 | 6.95 | 18 | 18 | 0 | 0 | 8.8 | 9.0 | 16 | 7.4 | 120 | 15 | 88 | 192 | 13 | 93 | 166 | 28 | 229 | 45 | |
| 11/14/90 | 6.77 | 6.99 | 19 | 17 | 0 | 0 | 9.0 | 9.3 | | | 100 | 11 | 89 | 114 | 10 | 91 | | | | | |
| 11/15/90 | 6.65 | 6.86 | 16 | 19 | 0 | 0 | 8.3 | 9.6 | | | | | | | | | 280 | 31 | | | |
| 11/19/90 | 6.74 | 6.43 | 17 | 16 | 0 | 0 | 8.9 | 8.9 | | | | | | | | | | | | | |
| 11/20/90 | 6.97 | 6.60 | 16 | 17 | 0 | 0 | 7.4 | 8.0 | 17 | 1.4 | 166 | 16 | 90 | 138 | 9 | 93 | 237 | 30 | 333 | 10 | |
| 11/26/90 | 6.86 | 6.76 | 16 | 18 | 0 | 0 | 8.5 | 8.8 | | | | | | | | | | | | | |
| 11/27/90 | 6.70 | 6.70 | 17 | 17 | 0 | 0 | 8.6 | 8.4 | 17 | 2.6 | 151 | 12 | 92 | 184 | 14 | 93 | 218 | 22 | 35 | 8 | |
| 11/28/90 | 6.45 | 6.65 | 20 | 20 | 0 | 0 | 7.3 | 6.9 | | | 134 | 10 | 93 | 148 | 11 | 92 | 182 | 18 | 208 | 25 | |

PAGE 117

**TABLE 3-2. NEW PROVIDENCE WASTEWATER TREATMENT PLANT
DAILY OPERATOR'S LOG DATA**

| DATE | PLANT EFFLUENT | | | | | | | | NH3 | | BOD | | | SUSPENDED SOLIDS | | | CBOD | | NBOD | | COMMENTS |
|----------|----------------------|----------------------|--------------------------|--------------------------|----------------------------------|----------------------------------|------------------------|------------------------|------|------|------|------|--------------------|------------------|------|--------------------|------|------|------|------|-------------|
| | PH A.M. (S.U.) | PH P.M. (S.U.) | TEMP. A.M. (deg C) | TEMP. P.M. (deg C) | SET. SOLIDS A.M. (mg/l) | SET. SOLIDS P.M. (mg/l) | D.O. A.M. (mg/l) | D.O. P.M. (mg/l) | INF. | EFF. | INF. | EFF. | PER. REM (%) | INF. | EFF. | PER. REM (%) | INF. | EFF. | INF. | EFF. | |
| 12/03/90 | 8.45 | 8.84 | 14 | 15 | 0 | 0 | 9.2 | 8.7 | | | | | | | | | | | | | |
| 12/04/90 | 8.50 | 8.50 | 17 | 17 | 0 | 0 | 8.8 | 9.2 | | | | | | | | | | | | | See Note #3 |
| 12/06/90 | 8.75 | 8.80 | 16 | 16 | 0 | 0 | 8.6 | 9.2 | 11 | 7.4 | 117 | 22 | 81 | 118 | 26 | 78 | 179 | 25 | 69 | 20 | |
| 12/10/90 | 8.72 | 8.74 | 15 | 17 | 0 | 0 | 8.2 | 9.1 | | | | | | | | | | | | | |
| 12/12/90 | 8.77 | 7.10 | 14 | 17 | 0 | 0 | 9.2 | 9.1 | 16 | 8 | 141 | 13 | 91 | 164 | 12 | 93 | 229 | 26 | 186 | 16 | |
| 12/13/90 | 7.06 | 6.82 | 13 | 18 | 0 | 0 | 8.0 | 9.3 | | | | | | | | | 385 | 34 | | | |
| 12/17/90 | 6.78 | 6.70 | 14 | 15 | 0 | 0 | 8.4 | 9.2 | | | | | | | | | | | | | |
| 12/18/90 | 6.88 | 6.78 | 15 | 15 | 0 | 0 | 9.2 | 8.5 | 16 | 7.8 | 145 | 17 | 88 | 296 | 8 | 97 | | | | | See Note #3 |
| 12/19/90 | 6.52 | 6.87 | 16 | 16 | 0 | 0 | 7.2 | 8.8 | | | | | | | | | 153 | 24 | 290 | 43 | |
| 12/25/90 | 7.21 | 7.20 | 12 | 12 | 0 | 0 | 8.6 | 9.2 | 15 | 6.7 | | | | 251 | 9 | 97 | 175 | 17 | 61 | 16 | |
| 12/26/90 | 7.30 | 6.69 | 13 | 14 | 0 | 0 | 9.2 | 8.4 | | | | | | | | | | | | | |
| 12/27/90 | 7.33 | 7.03 | 12 | 13 | 0 | 0 | 8.7 | 10.1 | | | 94 | 14 | 85 | 148 | 7 | 96 | | | | | |
| 01/01/91 | 6.30 | 7.26 | 12 | 15 | 0 | 0 | 9.2 | 10.0 | 9 | 4.2 | | | | 236 | 15 | 94 | 181 | 28 | 117 | 34 | |
| 01/02/91 | 6.82 | 6.97 | 14 | 15 | 0 | 0 | 8.2 | 9.6 | | | 119 | 16 | 87 | 148 | 10 | 93 | 142 | 24 | 103 | 54 | |
| 01/03/91 | 6.64 | 6.71 | 13 | 14 | 0 | 0 | 9.3 | 9.2 | | | | | | | | | | | | | |
| 01/04/91 | 6.70 | 6.67 | 13 | 14 | 0 | 0 | 9.3 | 9.2 | | | | | | | | | | | | | |
| 01/07/91 | 6.70 | 6.53 | 14 | 14 | 0 | 0 | 8.7 | 9.7 | | | | | | | | | | | | | |
| 01/08/91 | 6.43 | 7.17 | 13 | 13 | 0 | 0 | 9.0 | 10.1 | 15 | 8.8 | 168 | 15 | 91 | 664 | 18 | 97 | 228 | 24 | 189 | 45 | |
| 01/14/91 | 6.95 | 7.14 | 13 | 13 | 0 | 0 | 10.3 | 10.1 | | | | | | | | | | | | | |
| 01/15/91 | 6.78 | 6.74 | 13 | 15 | 0 | 0 | 9.7 | 9.6 | 25 | 14 | 127 | 14 | 89 | 154 | 18 | 88 | 182 | 24 | 93 | 15 | |
| 01/16/91 | 6.90 | 7.15 | 14 | 15 | 0 | 0 | 9.0 | 9.6 | | | | | | 98 | 32 | 67 | | | | | See Note #4 |
| 01/22/91 | 6.31 | 6.84 | 9 | 12 | 0 | 0 | 10.5 | 10.7 | 12 | 10 | 140 | 13 | 91 | 228 | 15 | 93 | 176 | 25 | 123 | 25 | |
| 01/23/91 | 6.94 | 7.23 | 11 | 13 | 0 | 0 | 9.7 | 10.3 | | | | | | | | | | | | | |
| 01/24/91 | 7.01 | 6.81 | 13 | 13 | 0 | 0 | 10.7 | 10.4 | | | | | | 286 | 17 | 94 | 135 | 13 | 148 | 12 | |
| 01/29/91 | 6.94 | 7.11 | 14 | 15 | 0 | 0 | 9.4 | 10.5 | 12 | 10 | 162 | 15 | 91 | 276 | 23 | 93 | 252 | 29 | 143 | | |
| 01/30/91 | 6.69 | 7.12 | 16 | 16 | 0 | 0 | 8.7 | 9.4 | | | | | | 188 | 17 | 91 | 204 | 32 | | | |
| 02/04/91 | 6.73 | 7.00 | 14 | 15 | 0 | 0 | 10.0 | 9.3 | | | | | | | | | | | | | |
| 02/05/91 | 7.09 | 7.09 | 15 | 17 | 0 | 0 | 9.3 | 9.3 | 15 | 14.5 | 167 | 11 | 93 | 640 | 11 | 98 | 229 | 25 | 191 | 19 | |
| 02/07/91 | 6.90 | 6.90 | 15 | 14 | 0 | 0 | 10.1 | 9.8 | | | 116 | 14 | 88 | 206 | 16 | 92 | 147 | 27 | 98 | 24 | |
| 02/12/91 | 7.53 | 7.25 | 10 | 10 | 0 | 0 | 9.5 | 9.9 | | | 231 | 14 | 94 | 304 | 15 | 95 | 214 | 25 | 204 | 25 | |
| 02/13/91 | 6.80 | 7.05 | 12 | 13 | 0 | 0 | 10.2 | 10.2 | 14 | 11 | 165 | 14 | 91 | 298 | 18 | 94 | | | | | |
| 02/19/91 | 6.78 | 7.05 | 14 | 15 | 0 | 0 | 9.2 | 9.8 | 15 | 11 | 116 | 15 | 87 | 108 | 21 | 81 | 139 | 23 | 264 | 50 | |
| 02/21/91 | 6.44 | 6.80 | 14 | 15 | 0 | 0 | 9.9 | 9.8 | | | 181 | 14 | 92 | 106 | 16 | 85 | | | | | |
| 02/25/91 | 6.65 | 6.91 | 14 | 15 | 0 | 0 | 10.2 | 9.5 | | | | | | | | | | | | | |
| 02/26/91 | 6.78 | 7.05 | 14 | 14 | 0 | 0 | 9.6 | 9.7 | 13 | 3.8 | 168 | 11 | 93 | 118 | 20 | 83 | 228 | 18 | 372 | 44 | |
| 03/04/91 | 6.86 | 6.94 | 15 | 15 | 0 | 0 | 9.7 | 9.4 | | | | | | | | | | | | | |
| 03/05/91 | 6.50 | 6.94 | 14 | 15 | 0 | 0 | 10.7 | 9.7 | 7.4 | 3.1 | 89 | 15 | 83 | 98 | 10 | 90 | 143 | 28 | 80 | 25 | |
| 03/06/91 | 6.42 | 6.80 | 15 | 15 | 0 | 0 | 9.6 | 9.9 | | | 108 | 15 | 86 | 80 | 15 | 75 | 191 | 33 | 80 | 18 | |
| 03/07/91 | 6.54 | 6.60 | 14 | 14 | 0 | 0 | 10.6 | 9.7 | | | 111 | 15 | 86 | 80 | 13 | 84 | | | | | |
| 03/11/91 | 6.97 | 6.95 | 11 | 13 | 0 | 0 | 10.3 | 10.2 | | | | | | | | | | | | | |
| 03/12/91 | 6.64 | 7.31 | 12 | 15 | 0 | 0 | 10.3 | 10.5 | 18 | 7 | 199 | 15 | 92 | 142 | 17 | 88 | | | | | |
| 03/13/91 | 6.78 | 6.78 | 13 | 14 | 0 | 0 | 9.3 | 10.2 | | | 158 | 11 | 93 | 140 | 12 | 91 | 205 | 25 | 75 | | |
| 03/14/91 | 6.79 | 6.71 | 13 | 15 | 0 | 0 | 10.0 | 9.8 | | | | | | | | | | | | | |
| 03/18/91 | 7.01 | 6.97 | 15 | 15 | 0 | 0 | 9.2 | 9.8 | | | | | | | | | | | | | |
| 03/19/91 | 6.90 | 6.80 | 15 | 16 | 0 | 0 | 9.4 | 9.7 | 15 | 10 | | | | 160 | 14 | 91 | | | | | |
| 03/20/91 | 6.99 | 6.85 | 14 | 15 | 0 | 0 | 8.9 | 9.1 | | | 144 | 13 | 91 | 104 | 5 | 95 | 201 | 27 | 142 | 12 | |
| 03/21/91 | 7.10 | 7.01 | 14 | 14 | 0 | 0 | 9.5 | 9.8 | | | | | | | | | 193 | 27 | | | |
| 03/22/91 | 6.93 | 6.74 | 13 | 15 | 0 | 0 | 9.3 | 9.7 | | | | | | | | | | | | | |

**TABLE 3-2. NEW PROVIDENCE WASTEWATER TREATMENT PLANT
DAILY OPERATOR'S LOG DATA**

| DATE | PLANT EFFLUENT | | | | | | | | NH3 | | BOD | | | SUSPENDED SOLIDS | | | CBOD | | NBOD | | COMMENTS |
|----------|---------------------|---------------------|--------------------------|--------------------------|----------------------------------|---------------------------------|-----------------------|-----------------------|------|------|------|------|---------------------|------------------|------|--------------------|------|------|------|------|----------|
| | PH A.M. (S U) | PH P M (S.U.) | TEMP. A.M. (deg C) | TEMP. P M. (deg C) | SET. SOLIDS A.M. (mg/l) | SET. SOLIDS P M (mg/l) | D O A.M. (mg/l) | D.O. P.M (mg/l) | INF. | EFF. | INF. | EFF. | PER. REM. (%) | INF. | EFF. | PER REM. (%) | INF. | EFF. | INF. | EFF. | |
| 03/25/91 | 6.83 | 6.97 | 14 | 15 | 0 | 0 | 9.1 | 10.0 | | | | | | | | | | | | | |
| 03/26/91 | 7.50 | 7.43 | 15 | 15 | 0 | 0 | 9.6 | 9.2 | 18 | 15 | 192 | 17 | 91 | 156 | 19 | 88 | | | | | |
| 03/27/91 | 7.36 | 7.22 | 17 | 18 | 0 | 0 | 8.5 | 9.3 | | | 146 | 15 | 90 | 128 | 17 | 87 | 225 | 28 | 73 | 14 | |
| 04/01/91 | 6.81 | 6.86 | 14 | 15 | 0 | 0 | 9.6 | 9.6 | | | | | | | | | | | | | |
| 04/03/91 | 7.25 | 7.06 | 15 | 16 | 0 | 0 | 8.7 | 9.0 | 17 | 3 | | | | 122 | 12 | 90 | 288 | 28 | 332 | | |
| 04/04/91 | 6.53 | 7.30 | 15 | 18 | 0 | 0 | 8.3 | 9.2 | | | 164 | 13 | 92 | 120 | 5 | 96 | 235 | 23 | 225 | 26 | |
| 04/08/91 | 6.85 | 6.51 | 18 | 22 | 0 | 0 | 9.5 | 8.4 | | | | | | | | | | | | | |
| 04/10/91 | 7.43 | 7.05 | 18 | 20 | 0 | 0 | 8.2 | 8.4 | 18 | 4.6 | 170 | 10 | 94 | 162 | 6 | 96 | 252 | 19 | 366 | 27 | |
| 04/12/91 | 6.58 | 6.74 | 15 | 18 | 0 | 0 | 9.7 | 9.9 | | | | | | | | | | | | | |
| 04/15/91 | 6.50 | 6.47 | 16 | 17 | 0 | 0 | 9.6 | 9.9 | | | | | | | | | | | | | |
| 04/16/91 | 6.95 | 7.14 | 16 | 20 | 0 | 0 | 9.7 | 8.7 | 22 | 2.7 | 171 | 12 | 93 | 134 | 2 | 99 | 228 | 24 | 192 | 16 | |
| 04/17/91 | 7.13 | 6.83 | 17 | 18 | 0 | 0 | 8.0 | 8.2 | | | 201 | 12 | 94 | 266 | 11 | 96 | 540 | 36 | | | |
| 04/22/91 | 7.12 | 7.10 | 14 | 14 | 0 | 0 | 9.8 | 9.3 | | | 89 | 21 | 75 | 100 | 18 | 82 | 128 | 33 | 102 | 26 | |
| 04/24/91 | 6.59 | 6.47 | 15 | 16 | 0 | 0 | 8.1 | 8.9 | | | | | | 80 | 10 | 88 | 80 | 27 | 148 | 11 | |
| 04/29/91 | 7.32 | 7.42 | 17 | 18 | 0 | 0 | 9.3 | 9.2 | | | | | | | | | | | | | |
| 05/01/91 | 7.49 | 7.58 | 18 | 20 | 0 | 0 | 8.2 | 8.3 | 17 | 6.13 | 170 | 13 | 92 | 160 | 15 | 91 | 260 | 28 | 290 | 22 | |
| 05/02/91 | 7.25 | 7.29 | 19 | 20 | 0 | 0 | 7.8 | 8.3 | | | 225 | 12 | 95 | 178 | 10 | 94 | | | | | |
| 05/06/91 | 6.70 | 6.90 | 18 | 18 | 0 | 0 | 8.3 | 8.6 | | | | | | | | | | | | | |
| 05/07/91 | 6.90 | 7.24 | 18 | 19 | 0 | 0 | 9.2 | 8.9 | 16.4 | 9.14 | 122 | 11 | 92 | 122 | 14 | 89 | 208 | 20 | 273 | 23 | |
| 05/08/91 | 7.11 | 7.47 | 18 | 20 | 0 | 0 | 8.2 | 9.2 | | | | | | 98 | 17 | 83 | | | | | |
| 05/14/91 | 7.08 | 7.23 | 22 | 24 | 0 | 0 | 7.2 | 8.0 | 24.6 | 8.73 | 167 | 22 | 87 | 160 | 17 | 89 | | | | | |
| 05/16/91 | 7.32 | 7.00 | 20 | 20 | 0 | 0 | 8.8 | 7.6 | | | | | | 218 | 13 | 94 | 235 | 19 | 15 | 9 | |
| 05/20/91 | 7.10 | 7.16 | 18 | 22 | 0 | 0 | 8.4 | 8.5 | | | | | | | | | | | | | |
| 05/21/91 | 7.40 | 7.42 | 18 | 23 | 0 | 0 | 9.2 | 8.1 | 17.1 | 4.12 | 181 | 9 | 95 | 158 | 4 | 97 | 210 | 22 | 180 | 12 | |
| 05/22/91 | 6.96 | 7.06 | 22 | 23 | 0 | 0 | 6.9 | 7.4 | | | | | | 140 | 13 | 91 | | | | | |
| 05/28/91 | 7.07 | 7.24 | 23 | 24 | 0 | 0 | 7.3 | 7.9 | | | | | | | | | | | | | |
| 05/30/91 | 7.19 | 7.20 | 24 | 26 | 0 | 0 | 7.6 | 7.5 | 13.3 | 4.21 | 157 | 10 | 94 | 188 | 2 | 99 | 270 | 35 | 138 | 19 | |
| 06/03/91 | 7.10 | 7.34 | 22 | 26 | 0 | 0 | 8.8 | 9.1 | | | | | | | | | | | | | |
| 06/04/91 | 6.89 | 7.30 | 22 | 24 | 0 | 0 | 8.1 | 8.4 | 14.3 | 1.07 | | | | | | | | | | | |
| 06/05/91 | 6.84 | 7.47 | 21 | 23 | 0 | 0 | 7.9 | 8.8 | | | 193 | 10 | 95 | 156 | 12 | 92 | | | | | |
| 06/06/91 | 7.42 | 7.05 | 20 | 23 | 0 | 0 | 9.5 | 8.7 | | | 168 | 10 | 94 | 154 | 10 | 94 | 236 | 30 | 334 | 15 | |
| 06/10/91 | 7.14 | 7.11 | 20 | 23 | 0 | 0 | 8.5 | 7.6 | | | | | | | | | | | | | |
| 06/12/91 | 7.03 | 7.00 | 24 | 25 | 0 | 0 | 7.1 | 7.3 | 15.2 | 2.15 | 324 | 14 | 96 | 290 | 15 | 95 | 363 | 20 | 238 | 35 | |
| 06/13/91 | 6.85 | 7.18 | 22 | 24 | 0 | 0 | 7.0 | 7.3 | | | 180 | 10 | 95 | 158 | 10 | 94 | | | | | |
| 06/17/91 | 6.77 | 7.22 | 24 | 24 | 0 | 0 | 7.9 | 6.6 | | | | | | | | | | | | | |
| 06/19/91 | 7.08 | 7.00 | 23 | 23 | 0 | 0 | 7.5 | 7.5 | 16.4 | 1.86 | 200 | 16 | 92 | 132 | 11 | 92 | 269 | 32 | 291 | 14 | |
| 06/20/91 | 6.95 | 7.05 | 24 | 25 | 0 | 0 | 6.0 | 7.2 | | | 190 | 14 | 93 | 124 | 11 | 91 | 238 | 35 | 242 | 17 | |
| 06/24/91 | 6.92 | 7.46 | 22 | 25 | 0 | 0 | 8.5 | 7.7 | | | | | | | | | | | | | |
| 06/25/91 | 7.10 | 7.08 | 22 | 24 | 0 | 0 | 8.2 | 7.5 | 20 | 5.97 | 170 | 10 | 94 | 194 | 7 | 96 | 255 | 19 | 285 | 25 | |
| 06/26/91 | 7.05 | 7.20 | 23 | 25 | 0 | 0 | 6.7 | 7.5 | | | | | | 184 | 11 | 94 | 227 | 29 | 417 | 16 | |
| 06/27/91 | 6.97 | 7.30 | 23 | 24 | 0 | 0 | 7.7 | 7.3 | | | 186 | 12 | 93 | 160 | 11 | 93 | 224 | 21 | 286 | 33 | |
| 07/01/91 | 7.01 | 7.13 | 23 | 26 | 0 | 0 | 7.9 | 8.6 | | | | | | | | | | | | | |
| 07/02/91 | 7.04 | 7.35 | 23 | 24 | 0 | 0 | 7.3 | 7.4 | 17.4 | 0.86 | 201 | 16 | 92 | 258 | 10 | 96 | | | | | |
| 07/04/91 | 6.73 | 7.11 | 23 | 24 | 0 | 0 | 7.0 | 6.4 | | | 190 | 14 | 93 | 250 | 1 | 99 | 232 | 25 | 308 | 19 | |
| 07/09/91 | 7.06 | 6.92 | 25 | 27 | 0 | 0 | 7.8 | 7.1 | 15.7 | 0.7 | 176 | 15 | 91 | 162 | 8 | 95 | 292 | 42 | 148 | 7 | |
| 07/10/91 | 6.94 | 7.01 | 23 | 26 | 0 | 0 | 6.4 | 7.3 | | | 149 | 13 | 92 | 166 | 8 | 95 | 154 | 23 | 236 | 22 | |
| 07/11/91 | 7.08 | 7.10 | 24 | 26 | 0 | 0 | 7.1 | 7.3 | | | | | | 138 | 4 | 97 | 232 | 35 | | | |
| 07/15/91 | 7.08 | 7.14 | 24 | 26 | 0 | 0 | 8.0 | 7.4 | | | | | | | | | | | | | |

See Note #3

**TABLE 3-2. NEW PROVIDENCE WASTEWATER TREATMENT PLANT
DAILY OPERATOR'S LOG DATA**

| DATE | PLANT EFFLUENT | | | | | | | | NH3 | | BOD | | | SUSPENDED SOLIDS | | | CBOD | | NBOD | | COMMENTS |
|--|----------------------|----------------------|--------------------------|--------------------------|----------------------------------|----------------------------------|------------------------|------------------------|------|------|------|----------|---------------------|------------------|----------|---------------------|------|------|------|------|----------|
| | PH A.M. (S.U.) | PH P.M. (S.U.) | TEMP. A.M. (deg C) | TEMP. P.M. (deg C) | SET. SOLIDS A.M. (mg/l) | SET. SOLIDS P.M. (mg/l) | D.O. A.M. (mg/l) | D.O. P.M. (mg/l) | INF. | EFF. | INF. | EFF. | PER. REM. (%) | INF. | EFF. | PER. REM. (%) | INF. | EFF. | INF. | EFF. | |
| 07/16/91 | 7.01 | 7.00 | 24 | 27 | 0 | 0 | 7.2 | 7.3 | 19.1 | 5.9 | 173 | 14 | 92 | 228 | 18 | 92 | 204 | 41 | 436 | 7 | |
| 07/22/91 | 7.17 | 6.93 | 25 | 28 | 0 | 0 | 7.5 | 8.5 | | | | | | | | | | | | | |
| 07/23/91 | 7.02 | 7.54 | 27 | 27 | 0 | 0 | 6.5 | 7.1 | 15.2 | 6.13 | 168 | 12 | 93 | 196 | 9 | 95 | 189 | 25 | 176 | 21 | |
| 07/24/91 | 6.90 | 6.81 | 25 | 28 | 0 | 0 | 6.4 | 7.1 | | | 152 | 9 | 94 | 172 | 15 | 92 | | | | | |
| 07/25/91 | 6.44 | 6.96 | 25 | 25 | 0 | 0 | 7.2 | 7.8 | | | | | | 170 | 12 | 93 | | | | | |
| 07/29/91 | 7.08 | 7.13 | 24 | 25 | 0 | 0 | 8.5 | 7.4 | | | | | | | | | | | | | |
| 07/31/91 | 6.90 | 7.04 | 24 | 28 | 0 | 0 | 9.2 | 7.4 | 14.3 | 2.88 | | | | 182 | 18 | 91 | 236 | 32 | 184 | 33 | |
| 08/01/91 | 6.95 | 6.99 | 25 | 27 | 0 | 0 | 6.2 | 6.8 | | | 205 | 16 | 92 | 144 | 15 | 90 | | | | | |
| 08/05/91 | 7.15 | 6.88 | 24 | 26 | 0 | 0 | 8.4 | 8.7 | | | | | | | | | | | | | |
| 08/06/91 | 7.10 | 7.24 | 23 | 26 | 0 | 0 | 9.8 | 8.7 | | 10.4 | | | | 162 | 16 | 90 | | | | | |
| 08/07/91 | 7.06 | 7.10 | 25 | 26 | 0 | 0 | 8.2 | 8.6 | | 3.99 | 148 | 12 | 92 | 180 | 11 | 94 | | | | | |
| 08/12/91 | 6.88 | 7.00 | 24 | 28 | < 0.1 | < 0.1 | 7.3 | 7.1 | | | | | | | | | | | | | |
| 08/13/91 | 6.91 | 7.15 | 24 | 28 | < 0.1 | < 0.1 | 7.5 | 7.5 | | 1.15 | 152 | 9 | 94 | 188 | 11 | 94 | 177 | 18 | 248 | 18 | |
| 08/14/91 | 6.88 | 7.06 | 25 | 27 | < 0.1 | < 0.1 | 8.4 | 7.0 | | | 182 | 10 | 95 | 146 | 12 | 92 | 215 | 13 | 255 | 25 | |
| 08/20/91 | 7.21 | 7.12 | 24 | 24 | < 0.1 | < 0.1 | 6.5 | 6.9 | | 6.28 | | | | 38 | 14 | 63 | | | | | |
| 08/21/91 | 7.17 | 7.14 | 23 | 26 | < 0.1 | < 0.1 | 6.3 | 7.7 | | | 73 | 7 | 91 | 110 | 11 | 90 | 97 | 15 | 27 | 12 | |
| 08/22/91 | 7.11 | 6.98 | 22 | 24 | < 0.1 | < 0.1 | 7.4 | 7.0 | | | 90 | 10 | 89 | 114 | 14 | 88 | 120 | 18 | 18 | 5 | |
| 08/27/91 | 7.15 | 7.01 | 23 | 25 | < 0.1 | < 0.1 | 6.8 | 6.7 | | | 170 | 11 | 94 | 182 | 21 | 88 | | | | | |
| 08/28/91 | 7.07 | 6.92 | 23 | 27 | < 0.1 | < 0.1 | 6.6 | 6.8 | | | 91 | 10 | 90 | 122 | 5 | 96 | | | | | |
| 08/29/91 | 6.69 | 6.97 | 25 | 27 | < 0.1 | < 0.1 | 6.5 | 6.3 | | | 168 | 11 | 93 | 134 | 5 | 96 | | | | | |
| DESIGN VALUE: -MAX. 30 DAY -MAX. 7 DAY | | | 10 Low 24 High | 10 Low 24 High | | | | | | | | 30 30 | | | 30 30 | | | | | | |
| MINIMUM | 6.02 | 6.31 | 8 | 8 | 0.0 | 0.0 | 5.1 | 5.6 | 4.1 | 0.2 | 73 | 6 | 88 | 38 | 1 | 62 | 80 | 13 | 15 | 5 | |
| MAXIMUM | 7.69 | 7.93 | 27 | 28 | < 0.1 | < 0.1 | 12.9 | 12.4 | 25.0 | 15.0 | 324 | 25 | 96 | 1328 | 32 | 99 | 540 | 47 | 436 | 85 | |
| AVERAGE | 6.93 | 7.09 | 18 | 20 | 0.0 | 0.0 | 8.5 | 8.6 | 15.3 | 5.1 | 149 | 13 | 91 | 164 | 12 | 91 | 207 | 25 | 174 | 27 | |

NOTES:

- 1) Dry Weather Average Flow = 0.9 MGD (0.3 MGD through each of the three UV Channels)
- 2) Peak Storm Flow = 6.0 MGD (2.0 MGD through each of the UV Channels)
- 3) Effluent Fecal Coliform Value was not included in majority of graphs.
- 4) Effluent Enterococci Value was not included in graphs.

APPENDIX C

NEW PROVIDENCE WWTP - GRAPHS

Figure 3-1. New Providence WWTP Eff. Fecal Coliform Vs Instant. Flow

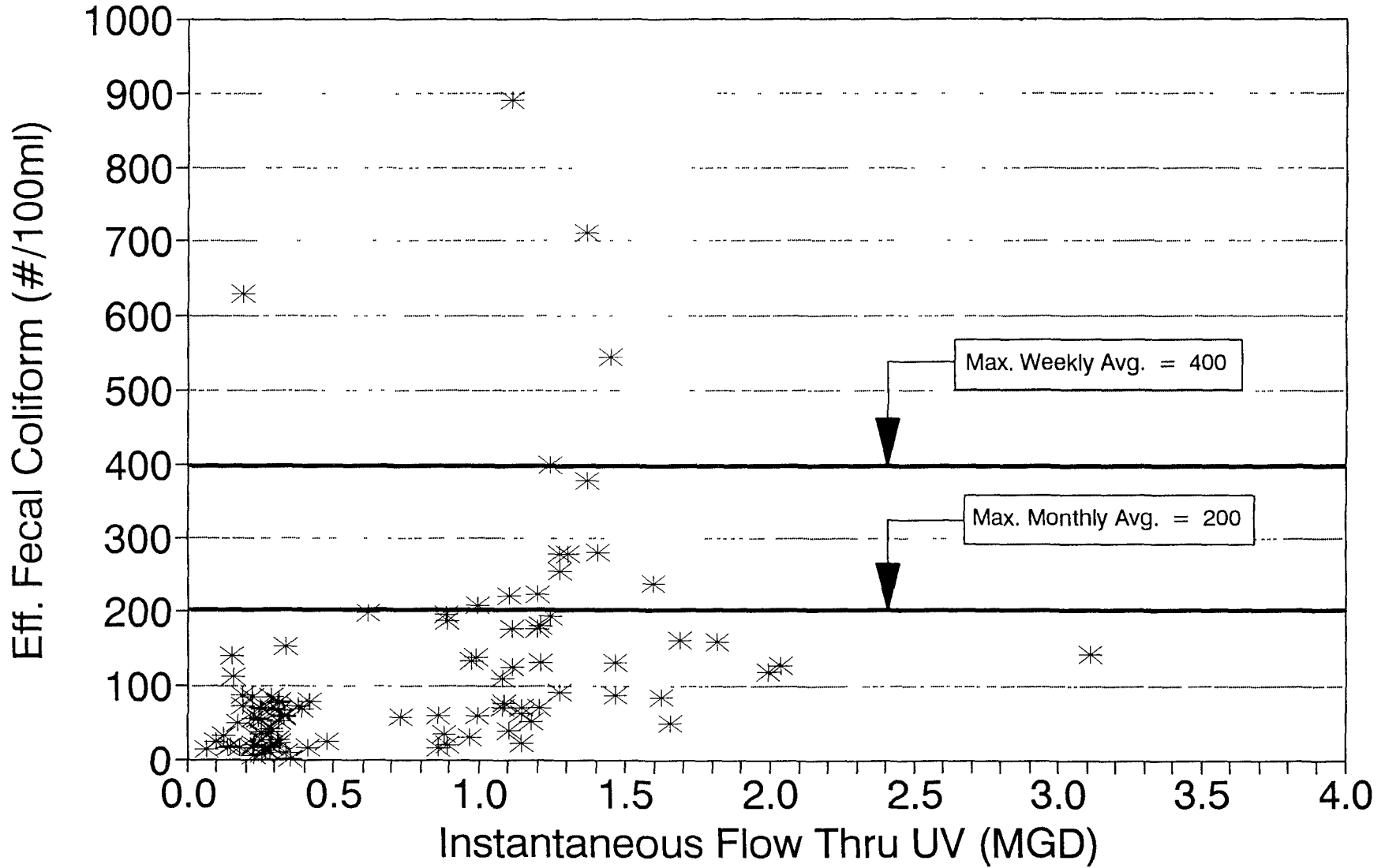

Figure 3-2. New Providence WWTP Eff. Fecal Col. Vs Inst. Q Per UV Bank

PAGE 123

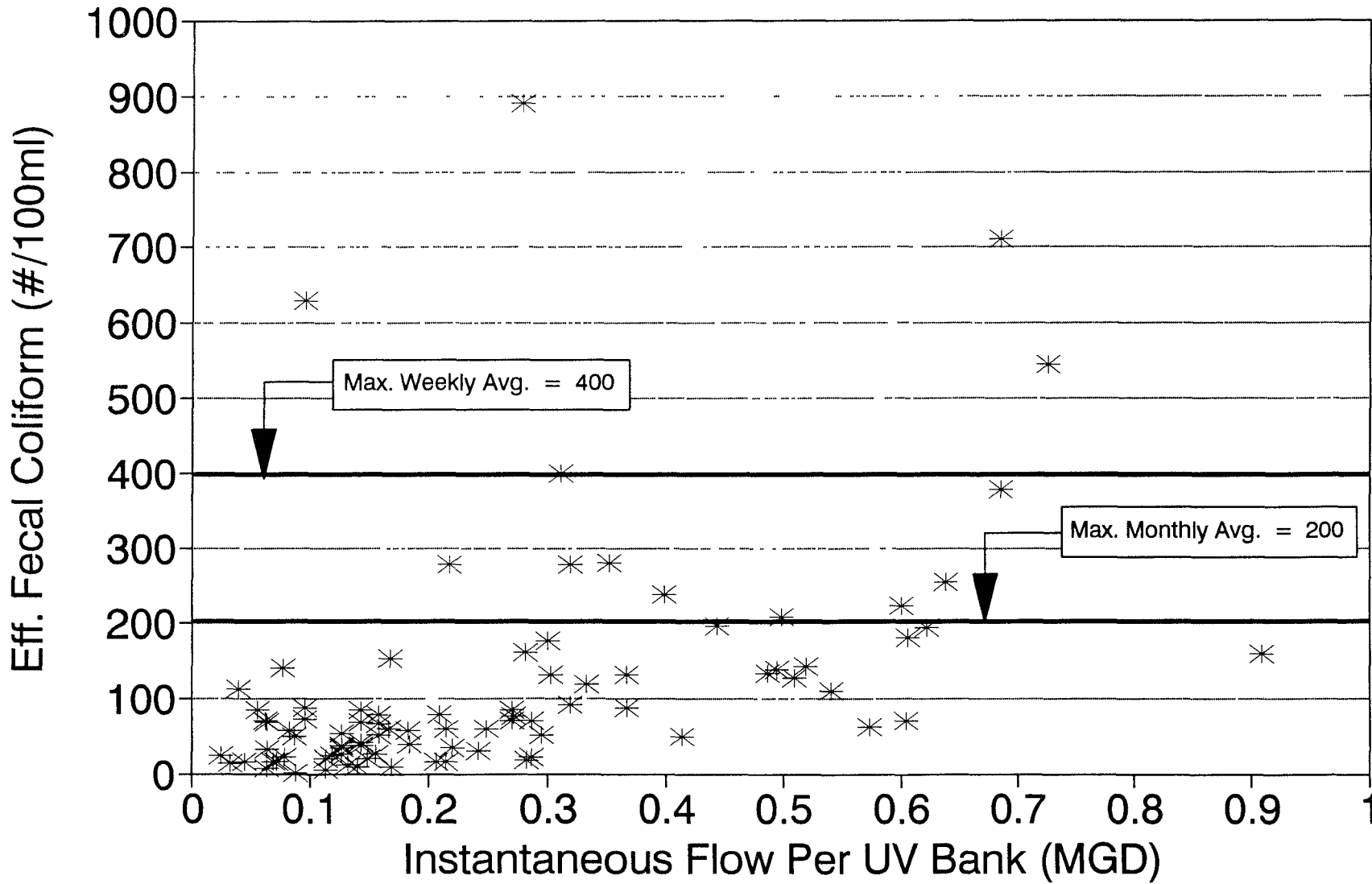

Figure 3-3. New Providence WWTP Eff. Fecal Coliform Vs. Eff. Plant Flow

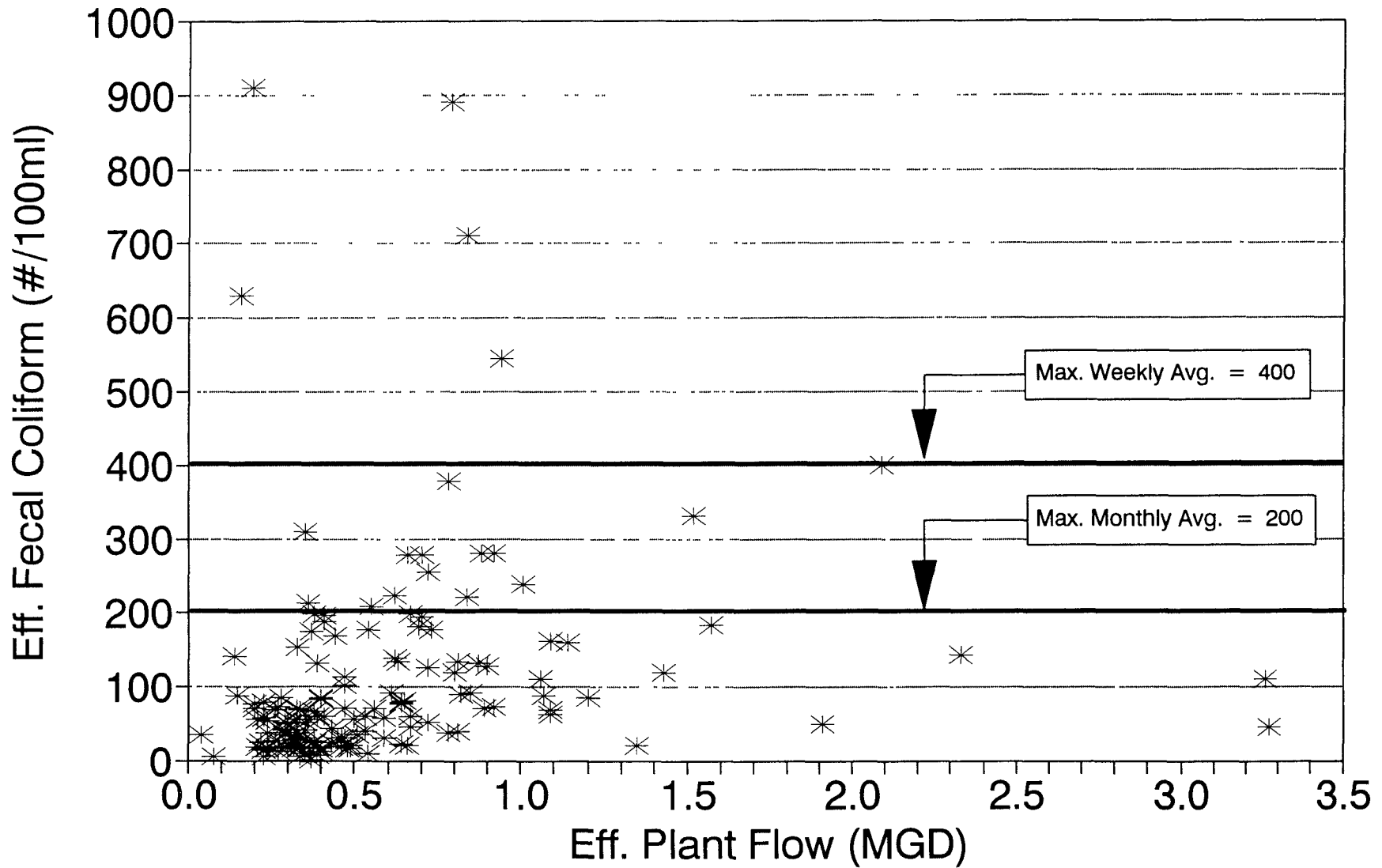

Figure 3-4. New Providence WWTP Eff Fecal Col. Vs Eff Flow Per UV Bank

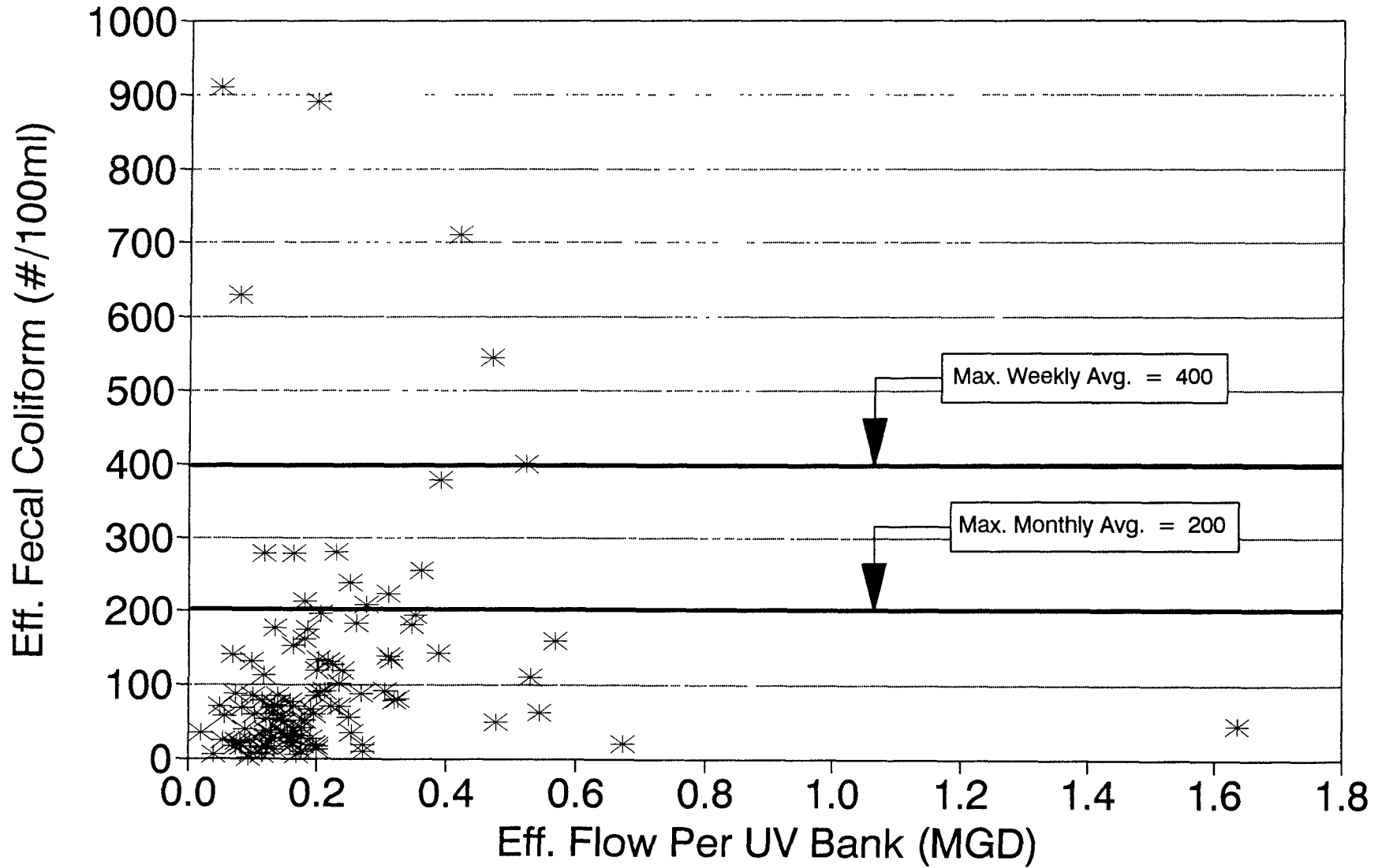

Figure 3-5. New Providence WWTP Eff Fecal Col. Vs Eff Suspended Solids

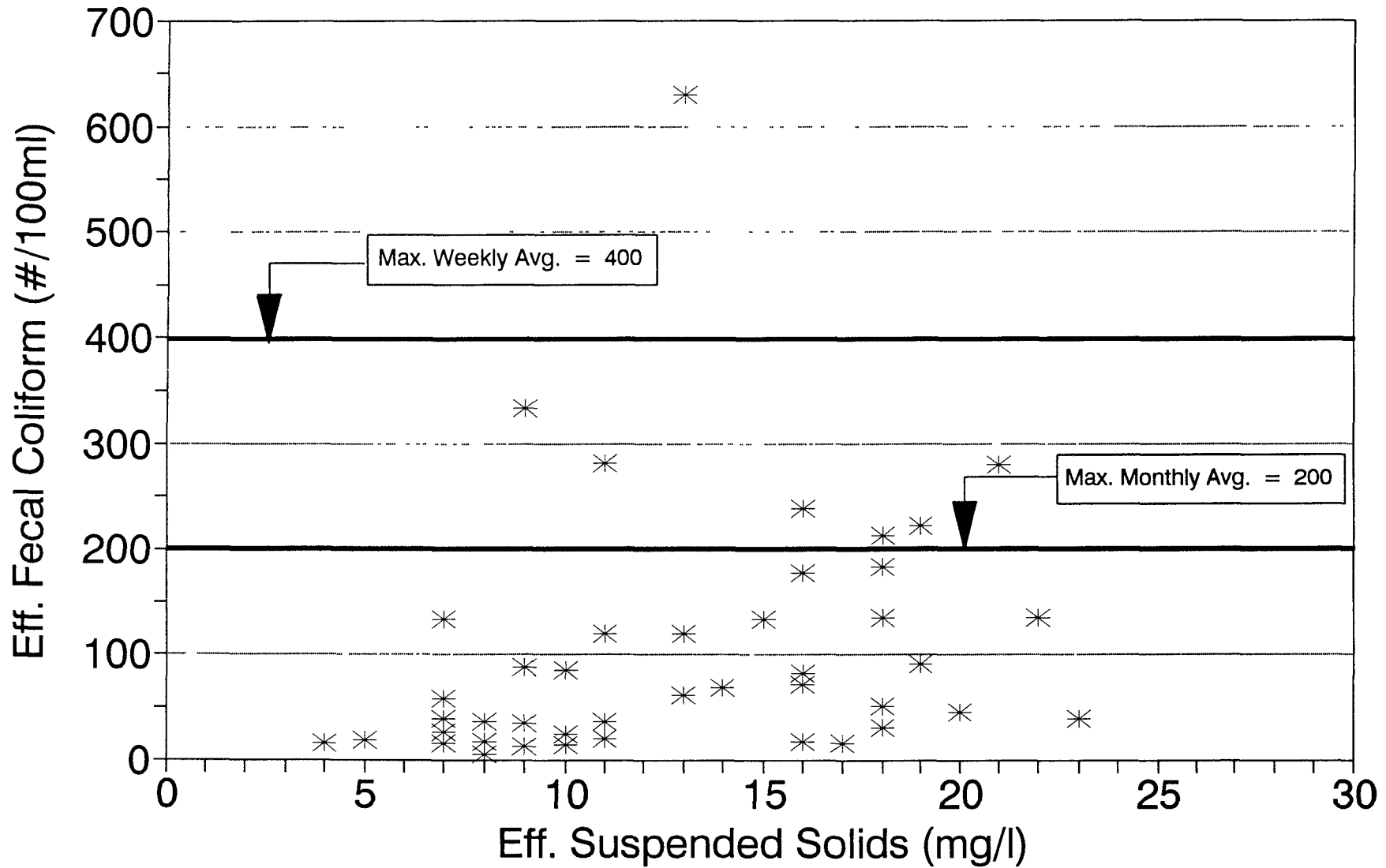

Figure 3-6. New Providence WWTP Eff Fecal Col. Vs Effluent Temp. (A.M.)

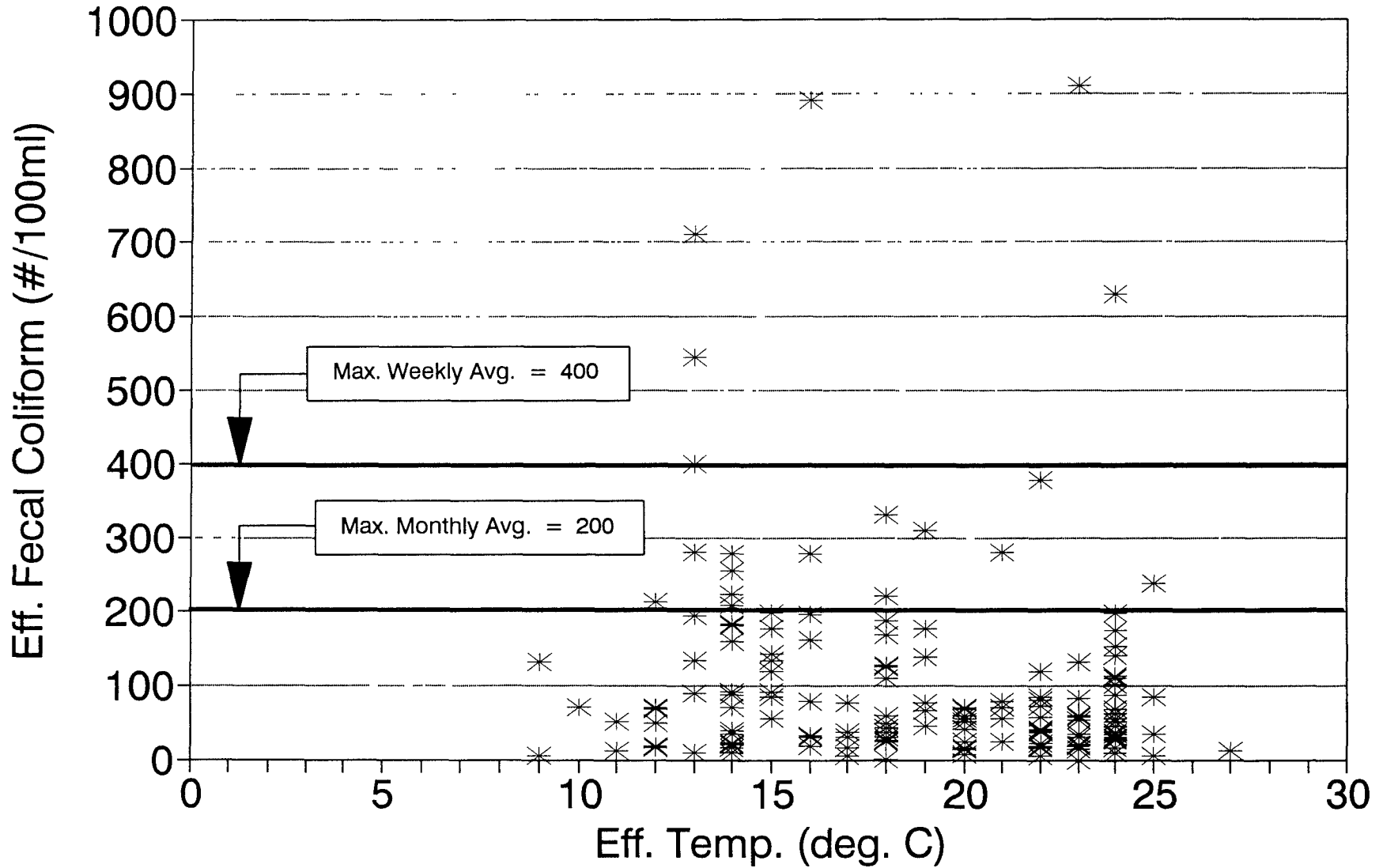

Figure 3-7. New Providence WWTP Eff Fecal Coliform Vs Eff. pH (A.M.)

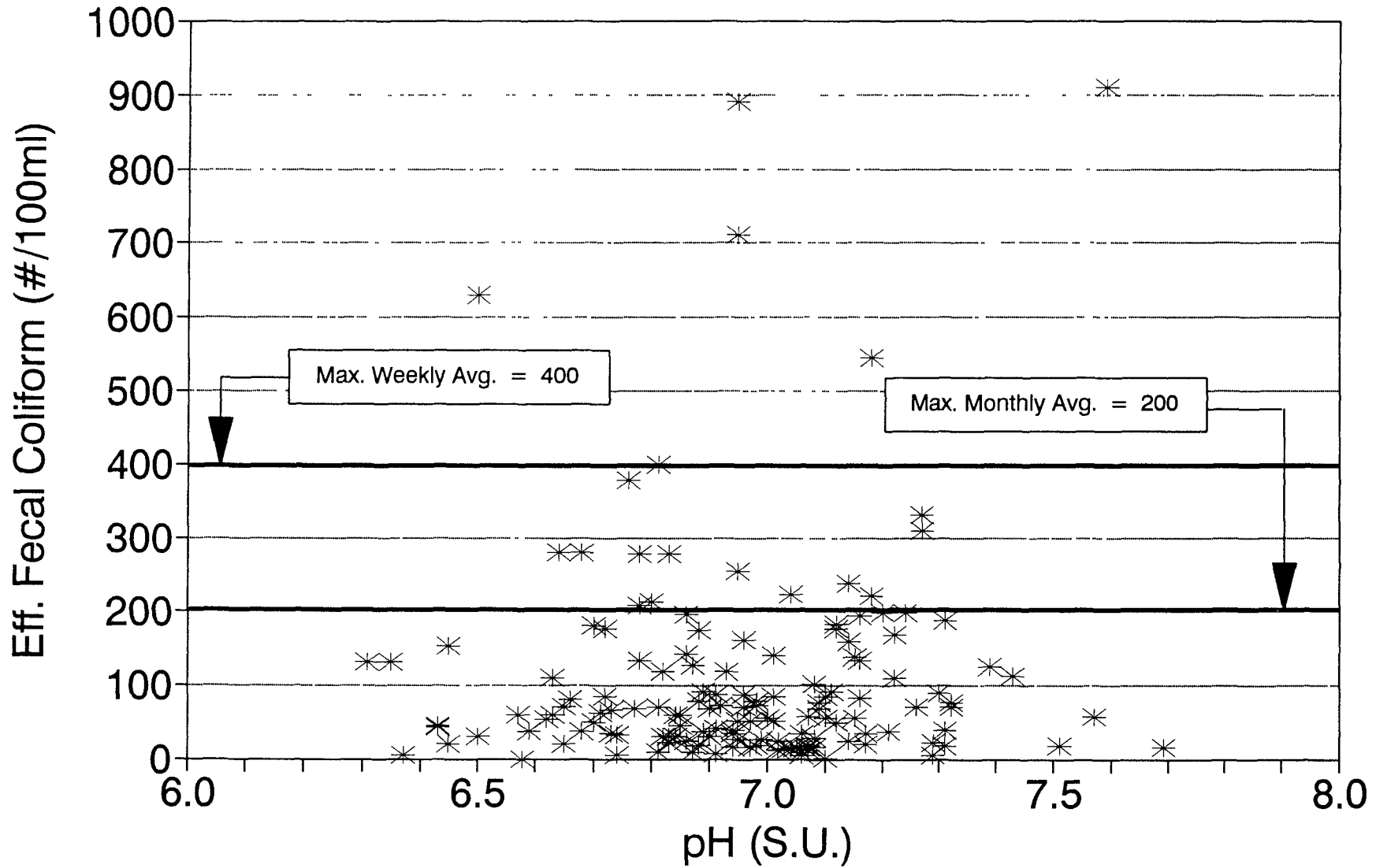

Figure 3-8. New Providence WWTP Eff. Fecal Coliform Vs Effluent BOD

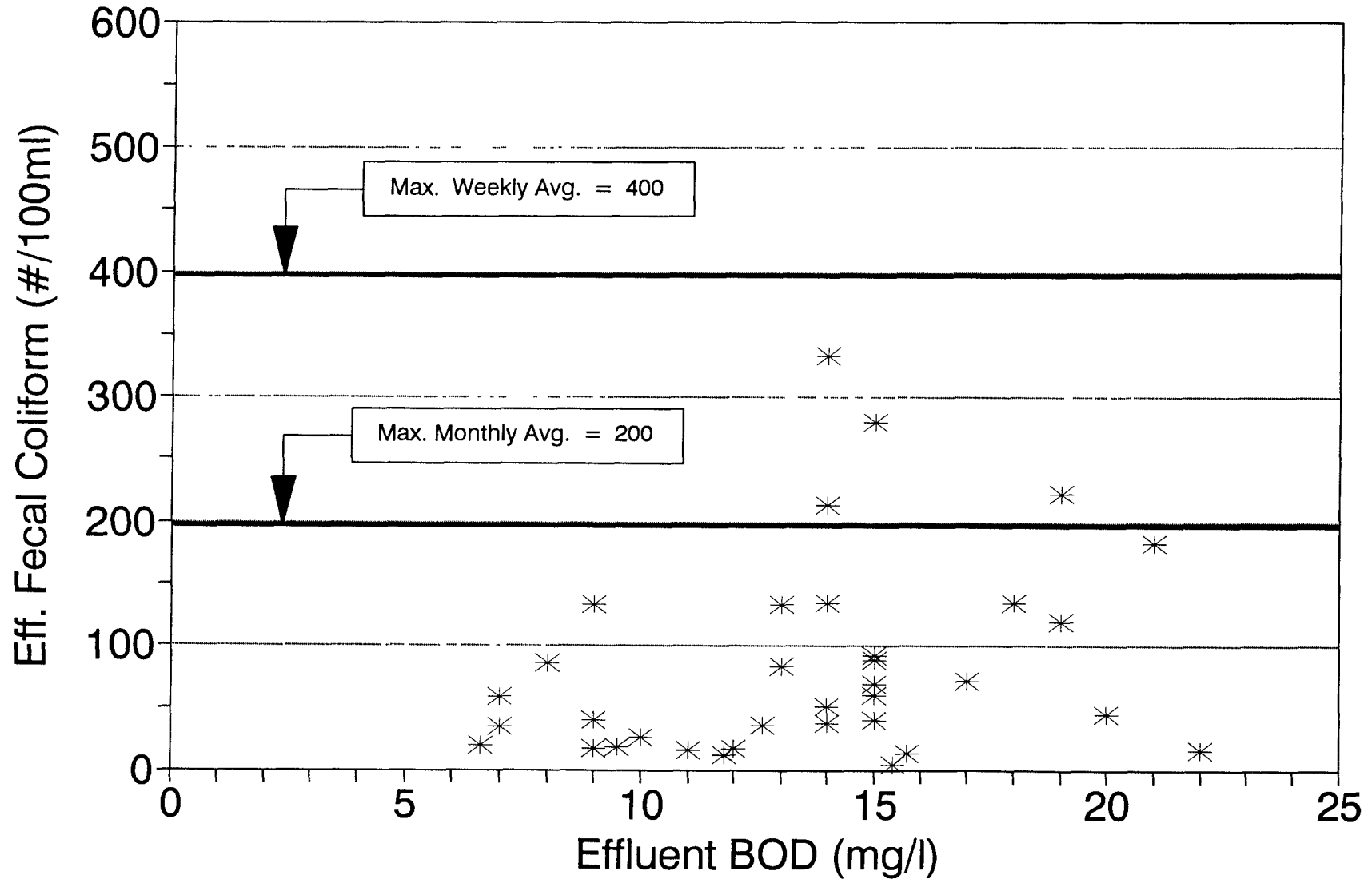

Figure 3-9. New Providence WWTP Eff. Fecal Coliform Vs Effluent CBOD

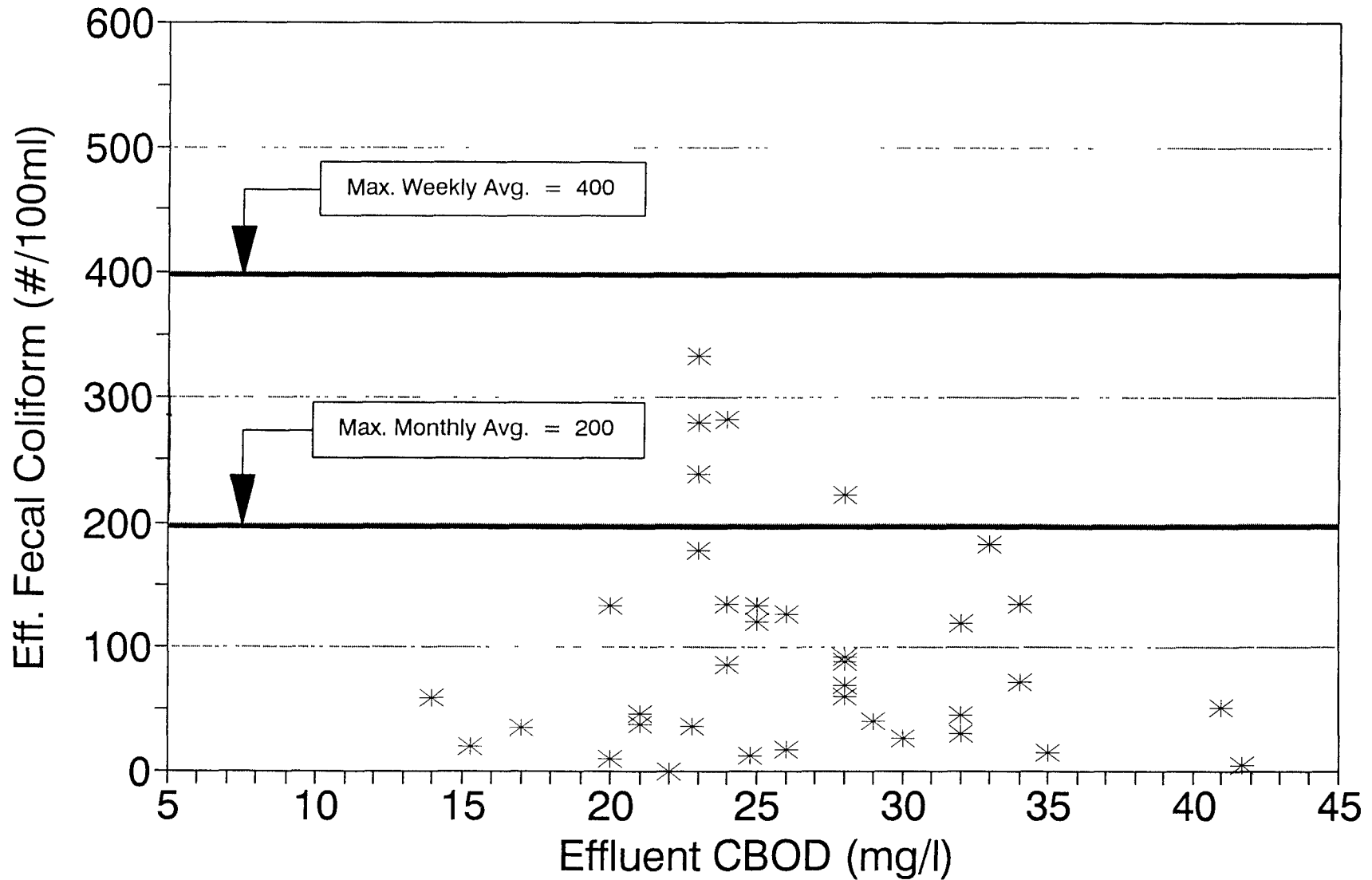

Figure 3-10. New Providence WWTP Eff. Fecal Coliform Vs Effluent NBOD

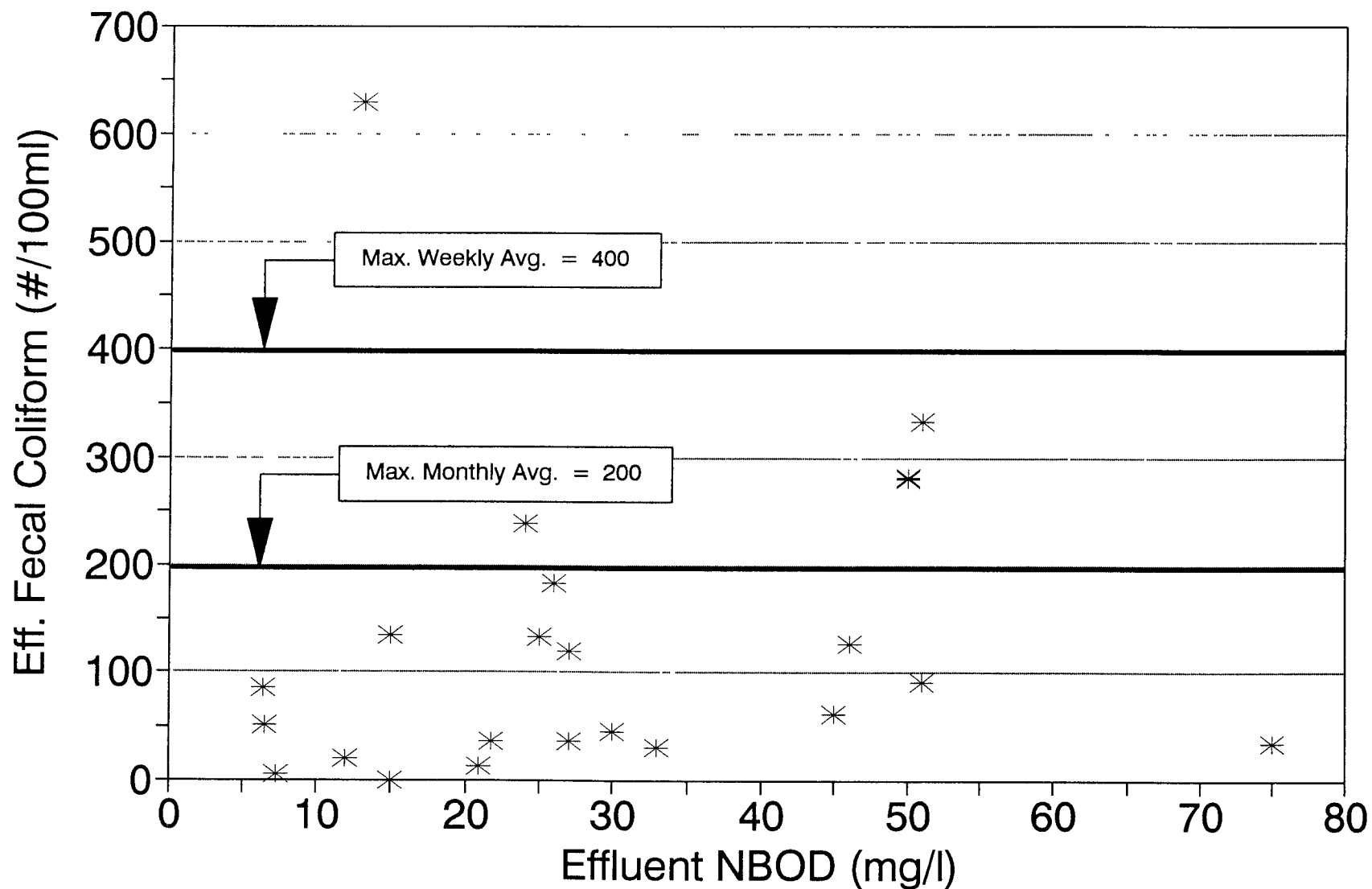

Figure 3-11. New Providence WWTP Eff. Fecal Coliform Vs Eff. D.O. (A.M.)

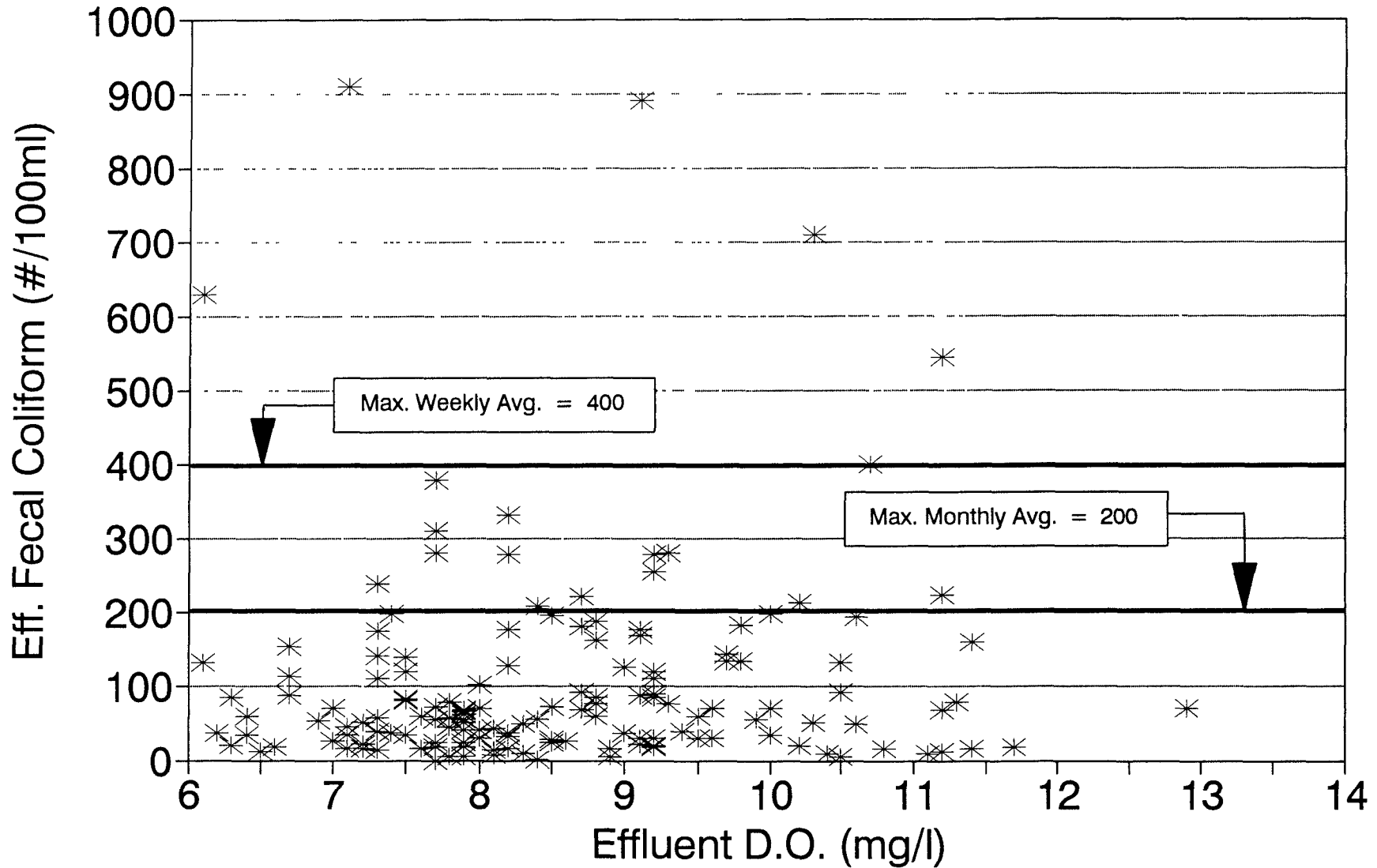

Figure 3-12. New Providence WWTP Eff. Enterococci Vs Inst. Q Per UV Bank

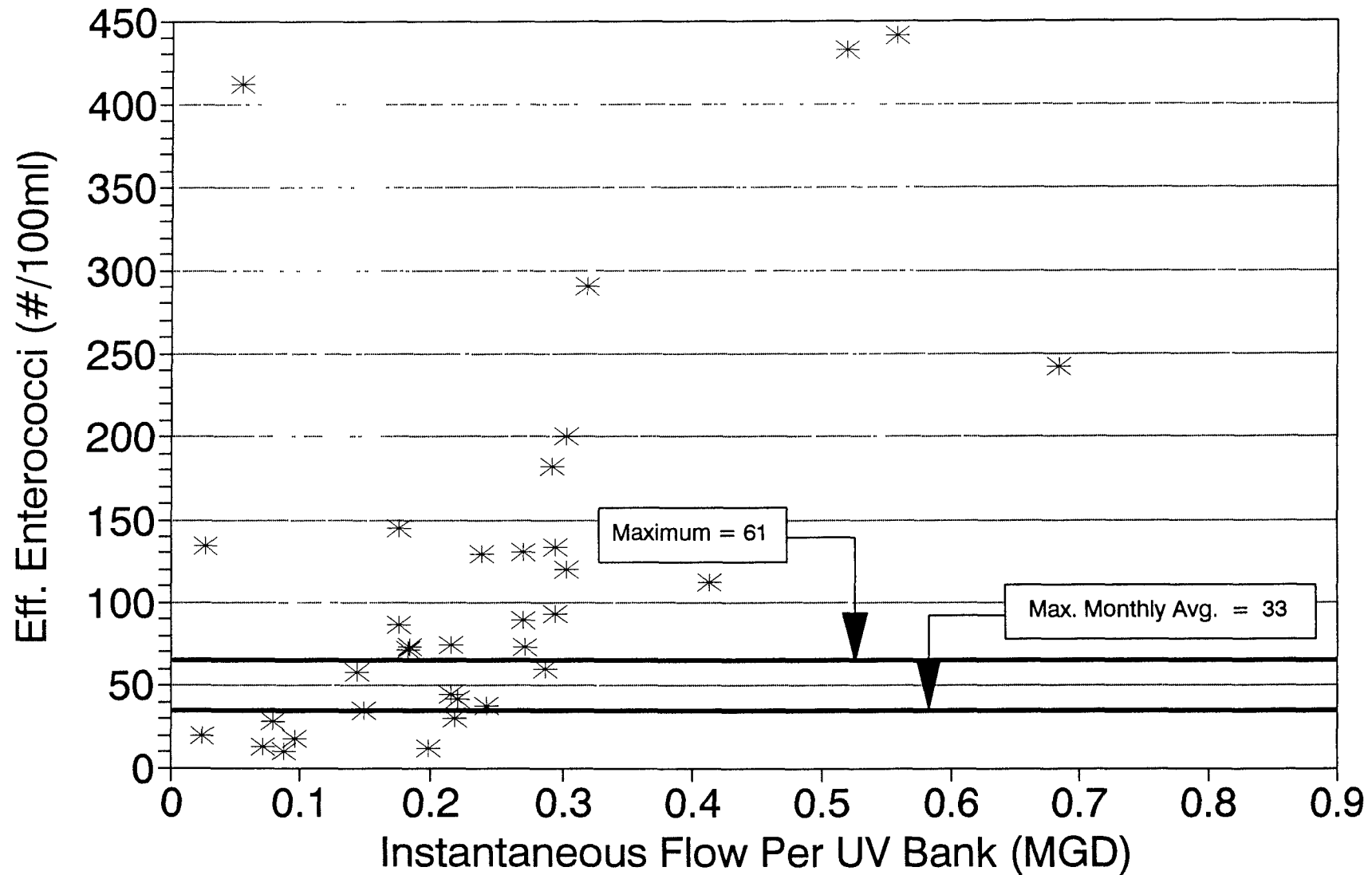

Figure 3-13. New Providence WWTP Eff Enterococci Vs Eff Flow Per UV Bank

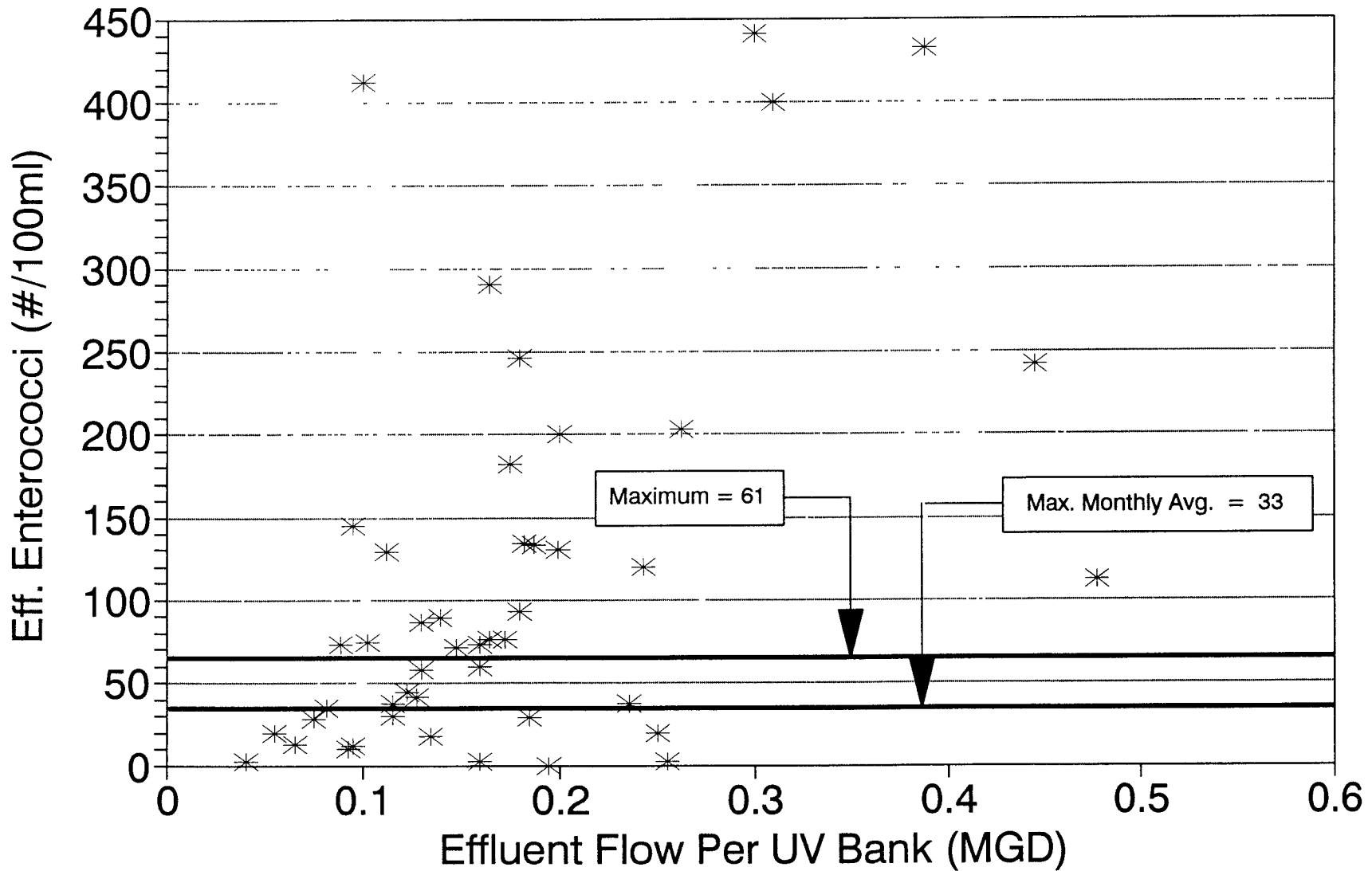

Figure 3-14. New Providence WWTP Eff Enterococci Vs Suspended Solids

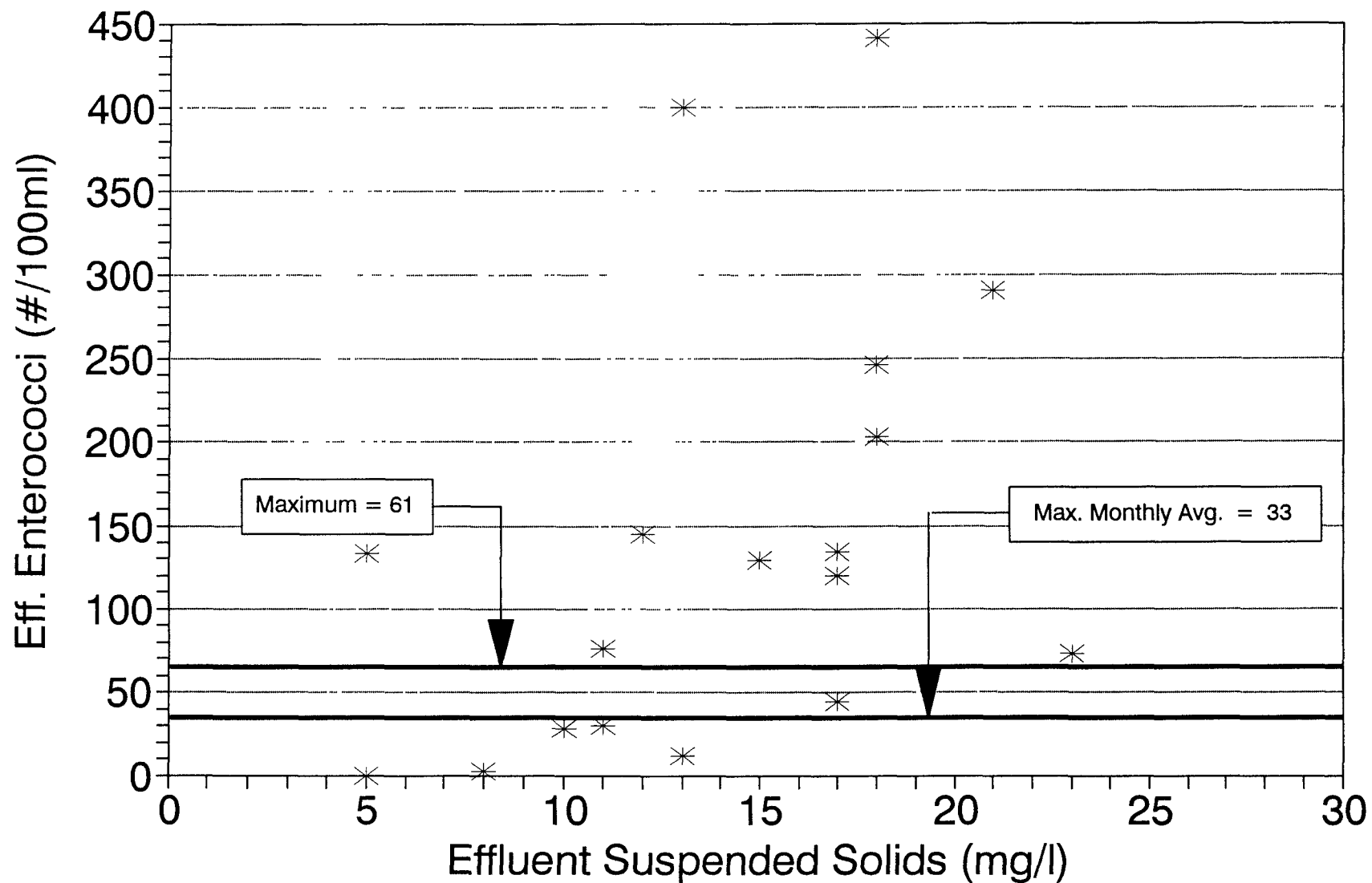

Figure 3-15. New Providence WWTP Eff Enterococci Vs Effluent BOD

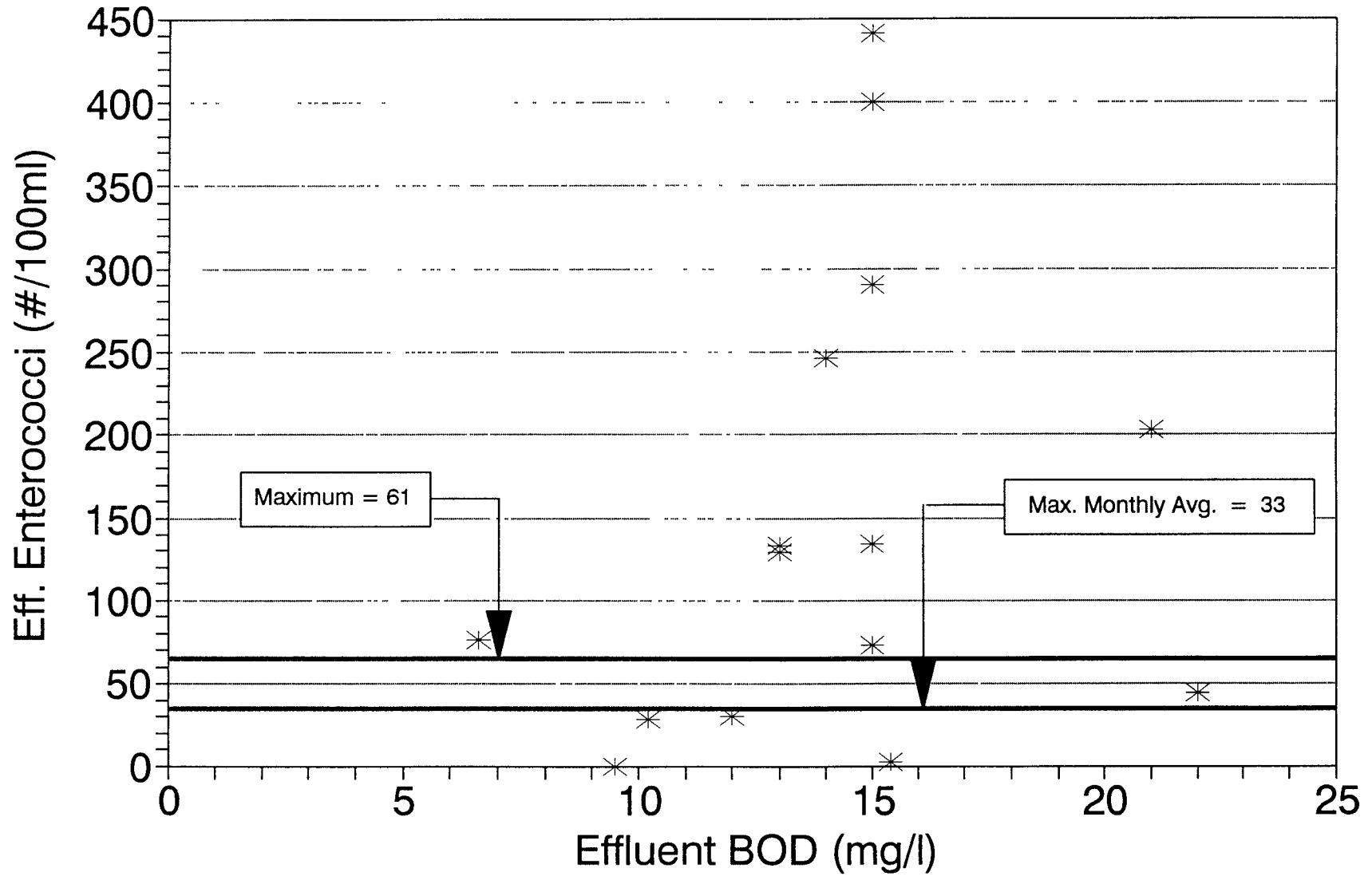

Figure 3-16. New Providence WWTP Eff. Fecal Coliform Vs. Eff. Plant Flow

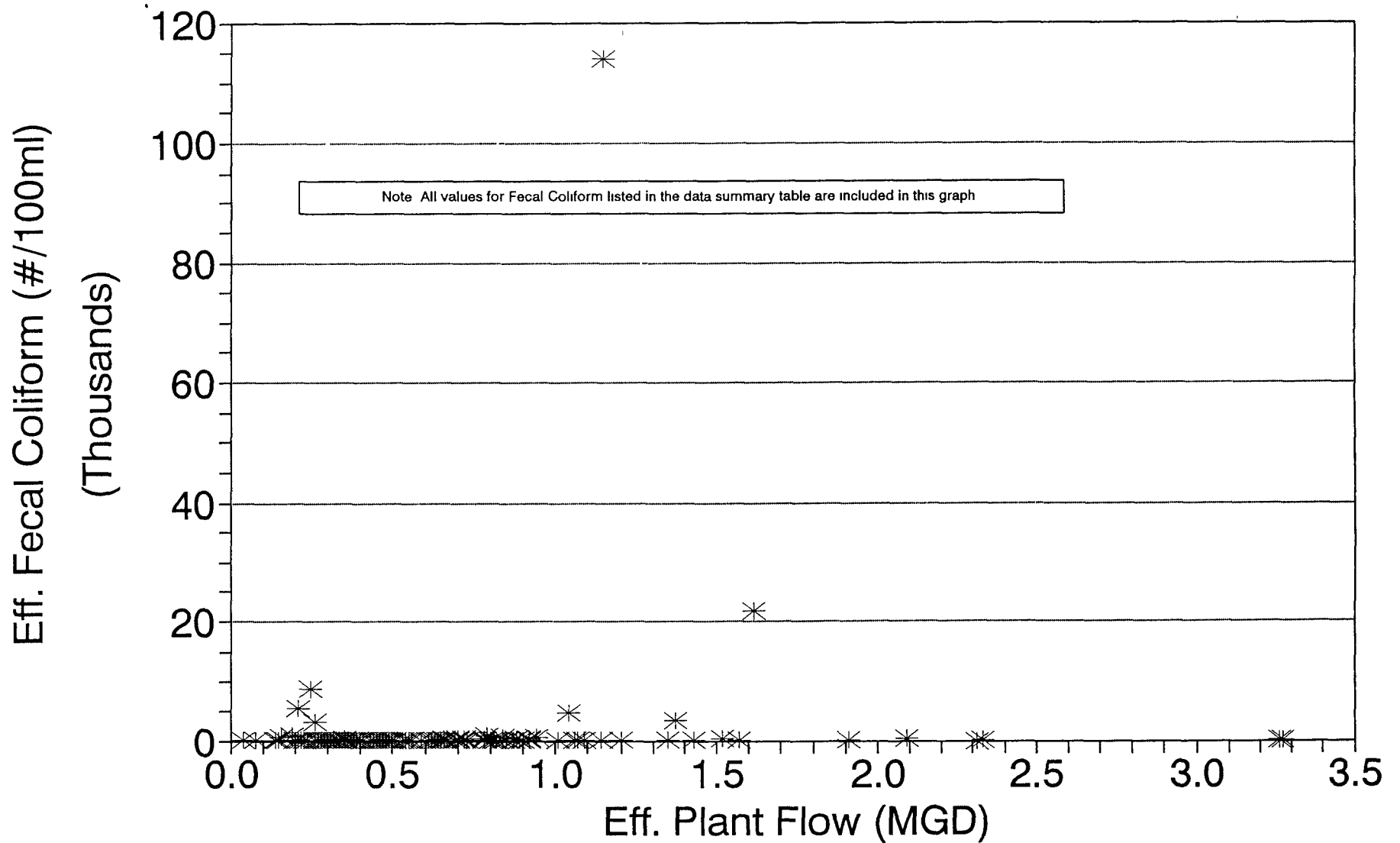
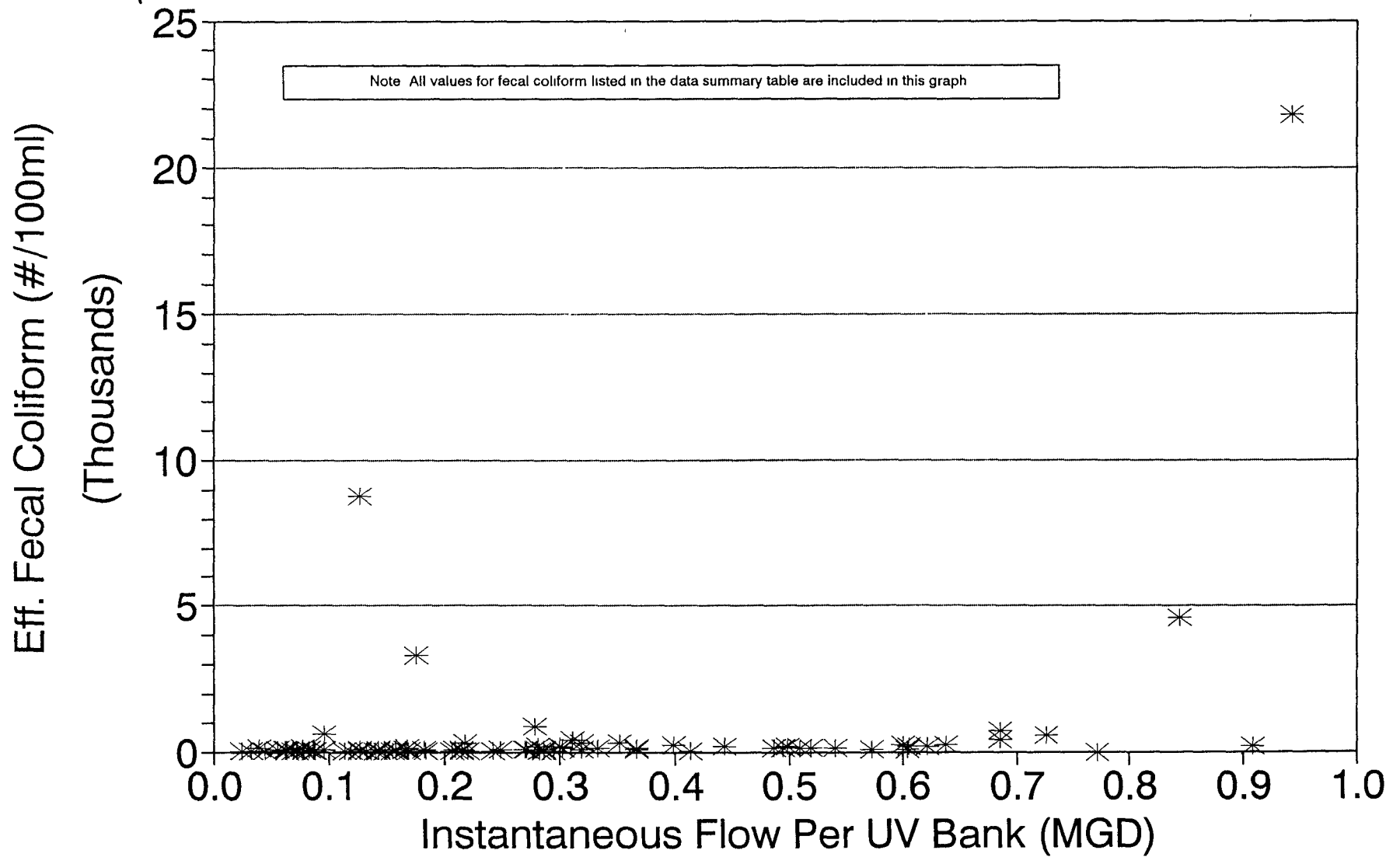

Figure 3-17. New Providence WWTP Eff. Fecal Col. Vs Inst. Q Per UV Bank



APPENDIX D

VERONA WWTP - NJPDES PERMIT



DEPARTMENT OF ENVIRONMENTAL PROTECTION

CN 402

Trenton, N.J. 08625



PERMIT

New Jersey Department of Environmental Protection grants this permit in accordance with your application, attachments accompanying same application, and applicable laws and regulations. This permit is also subject to the further conditions and stipulations enumerated in the supporting documents which are agreed to by the permittee upon acceptance of the permit.

| | | | |
|---|--|--|------------------------------|
| Permit No. NJ0024490 | Issuance Date 5/27/86 | Effective Date 7/1/86 | Expiration Date 6/30/91 |
| Name and Address of Applicant Township of the Borough of Verona 600 Bloomfield Avenue Verona, New Jersey 07044 | Location of Activity/Facility Verona Wastewater Treatment Plant Ozone Avenue Verona, N.J. | Name and Address of Owner SAME AS APPLICANT | |
| Issuing Division Water Resources | Type of Permit Municipal/Sanitary | Statute(s) 58:10A-1 <u>et seq.</u> | Application No. NJ0024490 |

This permit grants permission to: Borough of Verona

The applicant to discharge pollutants (treated effluent from the wastewater treatment facility) into the Peckman River, classified as FW-2-Nontrout waters in compliance with the provisions of the (Federal) Clean Water Act and the New Jersey Water Pollution Control Act subject to the general conditions set forth in this permit and conditions on reverse.

This permit is not intended to be nor shall it be construed to be a permit to discharge to ground water. This permit may be modified to include appropriate ground water discharge conditions.

This permit is issued pursuant to the provisions of the Regulations Concerning the New Jersey Pollutant Discharge Elimination System (N.J.A.C. 7:14A-1).

Approved by the Department of Environmental Protection
By Authority of
John W. Gaston, Jr., P.E., Director
Division of Water Resources

Arnold Schiffman Administrator DATE
Water Quality Management

EFFLUENT LIMITATIONS AND MONITORING REQUIREMENTS
FOR NJPDES/DSW PERMITS FOR MUNICIPAL (SANITARY) DISCHARGES

1. EFFLUENT LIMITATIONS

- A. Final Effluent Limitations. The permittee shall not discharge pollutants from any location(s) which are not specifically authorized by a valid NJPDES Permit.

In accordance with the compliance schedule contained in Part IV-A, Section 4 of this permit, during the period beginning on July 1, 1988 and lasting until the expiration date of this permit, discharges from outfall 004* shall be limited by the permittee as specified below:

- (1) Discharge so as to not violate the Surface Water Quality Standards for Peckman River, classified as FW2-Nontrout waters.
- (2) A substantially complete removal of settleable solids shall be achieved.
- (3) Discharge in compliance with Table III-A-1.
- (4) Except as specifically authorized in this permit, the permittee shall not discharge floating solids or visible foam.
- (5) The effluent values for pH shall remain within the limits of 6.5 to 8.5 standard units.
- (6) The 30-day average quantity of effluent discharged from the wastewater treatment facility shall not exceed 4.10 million gallons per day (MGD).

Outfall 004 will be a single outfall to the Peckman River constructed to eliminate outfalls 001 and 002.

B. Interim Effluent Limitations. In accordance with the compliance schedule contained in Part IV-A, Section 4 of this permit, during the period beginning on the effective date of this permit and lasting until June 30, 1988, the combined discharges (to be known as FAC for reporting purposes) from outfall 001 and 002 shall be limited by the permittee as specified below:

- (1) Same as permit condition 1.A(2).
- (2) Discharge in compliance with Table III-A-2.
- (3) Same as permit condition 1.A(4).
- (4) Same as permit condition 1.A(5).
- (5) The 30-day average quantity of effluent discharged from the wastewater treatment facility shall not exceed 4.10 MGD.

The location and description of outfalls 001 and 002 are as follows:

Treated effluent is discharged through two outfalls (001 and 002) into the Peckman River. The USGS coordinates of the outfalls are as follows:

Latitude: 40° 50' 38" North
Longitude: 74° 14' 06" West

TABLE III-A-1

FINAL EFFLUENT LIMITATIONS

(Outfall 004)

| EFFLUENT CHARACTERISTICS | Maximum Load Allocations ⁽¹⁾ | | Maximum Concentrations ⁽¹⁾ | | Minimum Percent ⁽¹⁾ Removal Limitations | |
|--|---|--|---|--|---|----------------------------|
| | Average Monthly Discharge Limitation (kg/day) | Average Weekly Discharge Limitation (kg/day) | Average Monthly Discharge Limitation (mg/l) | Average Weekly Discharge Limitation (mg/l) | Average Monthly | Any Four Hour Period |
| 5-Day 20°C Biochemical Oxygen Demand | 124 | 186 | 8 | 12 | | 95 |
| Ultimate Carbonaceous Biochemical Oxygen Demand | 186 | 279 | 12 | 18 | | |
| Suspended Solids | 124 | 186 | 8 | 12 | 85 | |
| Ammonia Nitrogen (NH ₃ -N) | 31 | 47 | 2 | 3 | | |
| Ultimate Nitrogenous Biochemical Oxygen Demand ⁽²⁾ | 155 | 233 | 10 | 15 | | |
| Fecal Coliform Organisms Number per 100 ml ⁽³⁾ | | | 200 | 400 | | |
| Dissolved Oxygen | | | ⁽⁴⁾ 6.0 | | | |
| Oil and Grease ⁽⁶⁾ | | | 10 | ⁽⁵⁾ 15 | | |
| Total Residual Chlorine | | | (non detectable) 0.02 | | | |
| Acute Toxicity (96 hr. LC 50) | | | 50% ⁽⁷⁾ | | | |
| | | | | | | |
| | | | | | | |
| | | | | | | |

- (1) Whichever is most stringent.
- (2) This parameter is equal to 4.57 times Total Kjeldahl Nitrogen.
- (3) Geometric Mean.
- (4) Minimum at any time.
- (5) In any single sample.
- (6) Until July 2, 1986, the permittee need meet only 15 mg/l on a monthly average and 30 mg/l in any single sample.
- (7) Minimum for any sample and/or test.

TABLE III-A-2

INTERIM EFFLUENT LIMITATIONS

FAC (Total from outfalls 001 and 002)

| EFFLUENT CHARACTERISTICS | Maximum Load Allocations ⁽¹⁾ | | Maximum Concentrations ⁽¹⁾ | | Minimum Percent ⁽¹⁾ Removal Limitations | |
|--|---|--|---|--|---|----------------------------|
| | Average Monthly Discharge Limitation (kg/day) | Average Weekly Discharge Limitation (kg/day) | Average Monthly Discharge Limitation (mg/l) | Average Weekly Discharge Limitation (mg/l) | Average Monthly | Any Four Hour Period |
| 5-Day 20°C Biochemical Oxygen Demand | 388 | 388 | (7) 25 | (7) 25 | | 90 |
| Ultimate Carbonaceous Biochemical Oxygen Demand | 466 | 699 | 30 | 45 | | |
| Suspended Solids | | | | | 85 | |
| Ammonia Nitrogen (NH ₃ -N) | | | | | | |
| Ultimate Nitrogenous Biochemical Oxygen Demand ⁽²⁾ | | | | | | |
| Fecal Coliform Organisms Number per 100 ml ⁽³⁾ | | | 200 | 400 | | |
| Dissolved Oxygen | | | (4) 6.0 | | | |
| Oil and Grease ⁽⁶⁾ | | | 10 | (5) 15 | | |
| Total Residual Chlorine | | | 1.50 | | | |
| Acute Toxicity (96 hr. LC 50) | | | 50% ⁽⁸⁾ | | | |
| | | | | | | |
| | | | | | | |
| | | | | | | |

- (1) Whichever is most stringent.
- (2) This parameter is equal to 4.57 times Total Kjeldahl Nitrogen.
- (3) Geometric Mean.
- (4) Minimum at any time.
- (5) In any single sample.
- (6) Until July 2, 1986, the permittee need meet only 15 mg/l on a monthly average and 30 mg/l in any single sample.
- (7) Average over any four-hour period of a day.
- (8) Minimum for any sample and/or test.

2. Influent and Effluent Monitoring Requirements (1)

A. Beginning on the effective date of this permit, discharges shall be monitored as specified below:

| <u>Minimum Monitoring Requirements</u> | | |
|---|---------------------------------|---------------------|
| <u>Effluent Characteristic...</u> | <u>Measurement Frequency...</u> | <u>Sample Type</u> |
| Total Flow, MGD..... | Continuous | ... Continuous |
| BOD5, mg/L..... | One per week | ... 24 hr composite |
| BOD5, kg/day..... | One per week | ... Calculated |
| BOD5, percent removal..... | One per week | ... Calculated |
| CBODu, mg/L..... | One per week | ... 24 hr composite |
| Suspended Solids, mg/L.... | One per week | ... Calculated |
| Suspended Solids, kg/day.. | One per week | ... Calculated |
| Suspended Solids, percent removal..... | One per week | ... Calculated |
| NBODu, mg/L..... | One per week | ... Calculated |
| Ammonia Nitrogen, mg/L(2). | One per week | ... Grab |
| Fecal Coliform, N per 100 ml (2) (3).... | Four per month | ... Grab |
| Dissolved Oxygen, mg/L(2). | One per week | ... Grab |
| Oil and Grease, mg/L (2).. | Monthly | ... Grab |
| Total Residual Chlorine, mg/L (2)..... | Twice per day | ... Grab |
| Settleable Solids, mL/L... | Twice per day | ... Grab |
| pH..... | Twice per day | ... Grab |
| Temperature, degree C..... | Twice per day | ... Grab |
| Acute Toxicity (96 hour LC 50), percent wastewater (2) (4)..... | Quarterly | |

-
- (1) Except where indicated influent and effluent measurement and testing is required.
 - (2) Only effluent testing required.
 - (3) Fecal Coliform calculations shall be reported in terms of geometric mean.

- (4) Bioassay testing using a properly conducted flow-through or static daily renewal test representing effluent quality for periods in excess of 24 hours shall be deemed acceptable. (In addition to being summarized and reported on a discharge monitoring form, bioassay test results shall be reported on forms provided by NJDEP (Bureau of Systems Analysis and Wasteload Allocation), postmarked no later than the 25th day of the month following the completed reporting period. Copies of the biomonitoring report form shall be submitted to the NJDEP and USEPA at the addresses indicated elsewhere in the permit, and to the Bureau of Systems Analysis and Wasteload Allocation, Monitoring and Planning Element, Division of Water Resources, CN-029, Trenton, NJ 08625.)
(See Appendix I)

B. Submission of Monitoring Reports

Monitoring results obtained during the previous month shall be summarized and reported on the appropriate form(s) specified by the Department. Monitoring reports are due on the first day of the month following the completed reporting period and shall be postmarked no later than the 25th day of that month. The first report is due on EDP + 1 month.

- C. Other requirements pertaining to monitoring and reporting are contained in Part I, Section 11 and Part II-A, Section 3.

3. Monitoring of and Control of Additional Discharge Locations

- A. In addition to the discharge(s) authorized under Part III-A from the outfalls(s) specified in Section 1A in accordance with the conditions of this permit, the only other discharge location from which pollutants may be discharged by the permittee is following:

Discharge No. 003, a high water emergency by-pass located at the head of the sewage treatment plant. The by-pass consists of an overflow pipe located at the head of the plant and discharges into the Peckman River.

- B. The permittee shall cease by-passing from Discharge No. 003 and shall eliminate (remove) this by-pass accordance with the Schedule of Compliance established in this permit. The permittee shall rehabilitate segments of the sanitary sewer collection system and disconnect illegal connections in order to minimize wastewater overflows at the treatment plant in accordance with the schedule of compliance established in this permit.
- i. There shall be no discharge (by-passing) during dry weather.
 - ii. The flow of this discharge (by-pass) shall be limited to that amount which exceeds the capacity of the sewerage system.
 - iii. The permittee shall inspect this by-pass facility at least once per week and within 18 hours following each precipitation event equivalent to or larger than one tenth of an inch of rain.
 - iv. The permittee shall comply with the reporting requirements established in Part I of this permit. Among other things, the permittee is required to notify this Department within 2 hours from the time the permittee becomes aware of this by-pass and to provide a written submission within five working days.

- v. NJDEP reserves the right to require additional abatement and/or mitigating measures including, but not limited to disinfection of the discharge.

APPENDIX E

VERONA WWTP -
DAILY OPERATOR'S LOG DATA

**TABLE 4-2. VERONA WASTEWATER TREATMENT PLANT
DAILY OPERATOR'S LOG DATA**

| DATE | TOTAL PLANT FLOW (MGD) | FECAL COLIFORM ORGANISMS | | | | | ENTEROCOCCI ORGANISMS | | | | | PLANT INFLUENT | | | | | |
|----------|------------------------|--------------------------|--------------------------|--------------------------|--------------------------|--|-----------------------|--------------------|--------------------------|--------------------------|--------------------------------|----------------|---------------|--------------------|--------------------|-----------------------|-----------------------|
| | | UV INF. (#/100 ml) | UV AND FINAL EFFLUENT | | | AVERAGE UV & FINAL EFFLUENT (#/100 ml) | UV INF. (#/100 ml) | UV EFFLUENT | | | AVERAGE UV EFFLUENT (#/100 ml) | PH (1) (S.U.) | PH (2) (S.U.) | TEMP. (1) (deg. C) | TEMP. (2) (deg. C) | SET. SOLIDS(1) (ML/L) | SET. SOLIDS(2) (ML/L) |
| | | | PLANT OUTFALL (#/100 ml) | INNER CHANNEL (#/100 ml) | OUTER CHANNEL (#/100 ml) | | | UV EFF. (#/100 ml) | INNER CHANNEL (#/100 ml) | OUTER CHANNEL (#/100 ml) | | | | | | | |
| 01/09/91 | 2.280 | | 166 | | | 166 | | | | | | 6.9 | 6.4 | 13 | 14 | 10 | 40 |
| 01/10/91 | 2.848 | | < 1 | | | 1 | | | | | | 7.0 | 7.0 | 14 | 14 | 10 | 8 |
| 01/11/91 | 2.870 | | < 1 | | | 1 | | | | | | 6.9 | 6.9 | 15 | 15 | 40 | 10 |
| 01/12/91 | 3.037 | | 3 | | | 3 | | | | | | 7.2 | 7.0 | 14 | 15 | 30 | 10 |
| 01/13/91 | 2.400 | | < 1 | | | 1 | | | | | | 6.6 | 7.0 | 14 | 15 | 20 | 10 |
| 01/14/91 | 3.008 | | < 1 | | | 1 | | | | | | 7.0 | 7.0 | 13 | 14 | 14 | 10 |
| 01/15/91 | 2.366 | | < 1 | | | 1 | | | | | | 6.5 | 6.8 | 13 | 14 | 50 | 30 |
| 01/16/91 | 2.585 | | < 1 | | | 1 | | | | | | 6.7 | 7.0 | 15 | 13 | 40 | 8 |
| 01/17/91 | 5.806 | | 6 | | | 6 | | | | | | 6.9 | 6.7 | 13 | 13 | 8 | 7 |
| 01/18/91 | 4.392 | | < 1 | | | 1 | | | | | | 7.1 | 6.9 | 14 | 15 | 20 | 38 |
| 01/19/91 | 4.041 | | < 1 | | | 1 | | | | | | 7.2 | 7.3 | 13 | 13 | 2 | 9 |
| 01/20/91 | 5.200 | | < 1 | | | 1 | | | | | | 7.0 | 7.1 | 11 | 12 | | 10 |
| 01/21/91 | 2.992 | | < 1 | | | 1 | | | | | | 6.9 | 7.1 | 14 | 14 | 23 | 15 |
| 01/22/91 | | | < 1 | | | 1 | | | | | | 7.1 | 7.2 | 12 | 14 | 23 | 10 |
| 01/23/91 | 2.739 | | < 1 | | | 1 | | | | | | 7.2 | 7.3 | 13 | 11 | 10 | 6 |
| 01/24/91 | 2.504 | | < 1 | | | 1 | | | | | | 7.2 | 7.2 | 11 | 12 | 10 | 6 |
| 01/25/91 | 2.441 | | < 1 | | | 1 | | | | | | 7.2 | 7.1 | 11 | 12 | 15 | 12 |
| 01/26/91 | | | < 1 | | | 1 | | | | | | 7.2 | 7.3 | 11 | 12 | 10 | 9 |
| 01/27/91 | 2.309 | | < 1 | | | 1 | | | | | | 6.9 | 7.3 | 11 | 12 | 25 | 10 |
| 01/28/91 | 2.697 | | < 1 | | | 1 | | | | | | 7.2 | 7.2 | 12 | 12 | 10 | 15 |
| 01/29/91 | 2.260 | | < 1 | | | 1 | | | | | | 7.1 | 7.3 | 11 | 12 | 14 | 7 |
| 02/01/91 | 2.380 | | < 1 | | | 1 | | | | | | 7.3 | 7.2 | 11 | 11 | 11 | 7 |
| 02/02/91 | 2.284 | | < 1 | | | 1 | | | | | | 7.2 | 7.3 | 11 | 13 | 10 | 5 |
| 02/03/91 | 2.285 | | < 1 | | | 1 | | | | | | 7.2 | 7.3 | 11 | 11 | 10 | 6 |
| 02/04/91 | 3.601 | | < 1 | | | 1 | | | | | | 7.1 | 7.2 | 12 | 12 | 11 | 10 |
| 02/05/91 | 2.229 | | < 1 | | | 1 | | | | | | 7.1 | 7.0 | 12 | 13 | 7 | 11 |
| 02/06/91 | 2.070 | | < 1 | | | 1 | | | | | | 7.1 | 7.4 | 12 | 12 | 11 | 5 |
| 02/07/91 | 2.434 | | < 1 | | | 1 | | | | | | 7.2 | 7.4 | 12 | 11 | 6 | 7 |
| 02/08/91 | 2.988 | | < 1 | | | 1 | | | | | | 7.1 | 7.3 | 12 | 12 | 15 | 8 |
| 02/09/91 | 2.539 | | < 1 | | | 1 | | | | | | 7.1 | 7.2 | 11 | 11 | 5 | 8 |
| 02/10/91 | 2.661 | | < 1 | | | 1 | | | | | | 7.1 | 7.5 | 11 | 12 | 6 | 9 |
| 02/11/91 | 2.626 | | < 1 | | | 1 | | | | | | 7.3 | 7.2 | 12 | 11 | 8 | 10 |
| 02/12/91 | 2.189 | | < 1 | | | 1 | | | | | | | | 12 | 11 | 6 | 10 |
| 02/13/91 | 2.599 | | < 1 | | | 1 | | | | | | 7.2 | 7.1 | 12 | 13 | 9 | 6 |
| 02/14/91 | 2.791 | | < 1 | | | 1 | | | | | | 7.2 | 7.3 | 11 | 12 | 2 | 3 |
| 02/15/91 | 2.133 | | < 1 | | | 1 | | | | | | 7.3 | 7.2 | 12 | 13 | 10 | 35 |
| 02/16/91 | 2.364 | | < 1 | | | 1 | | | | | | 7.2 | 7.3 | 11 | 12 | 1 | 7 |
| 02/17/91 | 2.579 | | < 1 | | | 1 | | | | | | 7.1 | 7.0 | 11 | 12 | 2 | 6 |
| 02/18/91 | 2.831 | | < 1 | | | 1 | | | | | | 7.2 | 7.5 | 11 | 12 | 6 | 10 |
| 02/19/91 | 2.789 | | < 1 | | | 1 | | | | | | 7.3 | 7.2 | 11 | 11 | 7 | 5 |
| 02/20/91 | 2.579 | | < 1 | | | 1 | | | | | | 7.2 | 7.2 | 12 | 12 | 5 | 8 |
| 02/21/91 | 2.579 | | < 1 | | | 1 | | | | | | 7.2 | 7.5 | 11 | 12 | 6 | 8 |
| 02/22/91 | 2.397 | | < 1 | | | 1 | | | | | | 7.3 | 7.2 | 12 | 12 | 12 | 9 |
| 02/23/91 | 2.311 | | < 1 | | | 1 | | | | | | 7.3 | 7.3 | 11 | 11 | 6 | 9 |
| 02/24/91 | 2.431 | | < 1 | | | 1 | | | | | | 7.3 | 7.4 | 12 | 12 | 6 | 6 |
| 02/25/91 | 2.205 | | < 1 | | | 1 | | | | | | 7.3 | 7.4 | 12 | 12 | 10 | 8 |
| 02/26/91 | 2.276 | | < 1 | | | 1 | | | | | | 7.4 | 7.4 | 11 | 12 | 28 | 7 |
| 02/27/91 | 3.180 | | 1 | | | 1 | | | | | | 7.1 | 7.2 | 12 | 13 | 6 | 5 |
| 02/28/91 | 3.180 | | 0.2 | | | 0.2 | | | | | | 7.0 | 7.1 | 13 | 13 | 6 | 5 |
| 03/01/91 | 2.120 | | 20 | | | 20 | | | | | | 7.2 | 7.0 | 13 | 14 | 8 | 30 |

**TABLE 4-2. VERONA WASTEWATER TREATMENT PLANT
DAILY OPERATOR'S LOG DATA**

| DATE | TOTAL PLANT FLOW (MGD) | FECAL COLIFORM ORGANISMS | | | | | ENTEROCOCCI ORGANISMS | | | | | PLANT INFLUENT | | | | | |
|----------|------------------------|--------------------------|--------------------------|--------------------------|--------------------------|--|-----------------------|--------------------|--------------------------|--------------------------|--------------------------------|----------------|---------------|--------------------|--------------------|-----------------------|-----------------------|
| | | UV INF. (#/100 ml) | UV AND FINAL EFFLUENT | | | AVERAGE UV & FINAL EFFLUENT (#/100 ml) | UV INF. (#/100 ml) | UV EFFLUENT | | | AVERAGE UV EFFLUENT (#/100 ml) | PH (1) (S.U.) | PH (2) (S.U.) | TEMP. (1) (deg. C) | TEMP. (2) (deg. C) | SET. SOLIDS(1) (ML/L) | SET. SOLIDS(2) (ML/L) |
| | | | PLANT OUTFALL (#/100 ml) | INNER CHANNEL (#/100 ml) | OUTER CHANNEL (#/100 ml) | | | UV EFF. (#/100 ml) | INNER CHANNEL (#/100 ml) | OUTER CHANNEL (#/100 ml) | | | | | | | |
| 03/02/91 | 2.389 | | < 1 | | | 1 | | | | | | 7.1 | 7.2 | 12 | 12 | 11 | 8 |
| 03/03/91 | 5.000 | | < 1 | | | 1 | | | | | | 7.2 | 7.5 | 12 | 13 | 3 | 10 |
| 03/05/91 | 3.018 | | < 1 | | | 1 | | | | | | 7.1 | 7.0 | 11 | 11 | 4 | 3 |
| 03/06/91 | 3.582 | | < 1 | | | 1 | | | | | | 7.0 | 7.1 | 12 | 12 | 4 | 5 |
| 03/07/91 | 2.985 | | < 1 | | | 1 | | | | | | 7.2 | 7.0 | 12 | 12 | 9 | 17 |
| 03/08/91 | 3.031 | | < 1 | | | 1 | | | | | | 7.0 | 7.0 | 11 | 12 | 5 | 19 |
| 03/11/91 | 2.511 | | 0.19 | | | 0.19 | | | | | | 7.0 | 7.1 | 12 | 12 | 12 | 13 |
| 03/12/91 | 2.415 | | < 1 | | | 1 | | | | | | 7.1 | 7.1 | 12 | 12 | 11 | 9 |
| 03/13/91 | 2.278 | | < 1 | | | 1 | | | | | | 7.1 | 7.0 | 12 | 12 | 8 | 12 |
| 03/14/91 | 2.860 | | < 1 | | | 1 | | | | | | 7.4 | 6.8 | 13 | 13 | 22 | 22 |
| 03/15/91 | 3.607 | | < 1 | | | 1 | | | | | | 6.8 | 6.9 | 12 | 13 | 33 | 32 |
| 03/16/91 | 2.809 | | 1 | | | 1 | | | | | | 7.4 | 6.4 | 11 | 12 | 10 | 15 |
| 03/17/91 | 3.057 | | < 1 | | | 1 | | | | | | 6.4 | 7.1 | 12 | 13 | 12 | 10 |
| 03/18/91 | 3.486 | | < 1 | | | 1 | | | | | | 7.1 | 7.0 | 12 | 12 | 12 | 21 |
| 03/19/91 | 2.947 | | < 1 | | | 1 | | | | | | 7.0 | 6.8 | 12 | 12 | 11 | 40 |
| 03/20/91 | 2.708 | | < 1 | | | 1 | | | | | | 7.2 | 7.1 | 12 | 13 | 4 | 19 |
| 03/21/91 | 2.389 | | < 1 | | | 1 | | | | | | 7.0 | 6.7 | 13 | 13 | 35 | 78 |
| 03/22/91 | 2.158 | | < 1 | | | 1 | | | | | | 7.2 | 7.4 | 12 | 13 | 7 | 8 |
| 03/23/91 | 3.025 | | < 1 | | | 1 | | | | | | 7.3 | 7.2 | 11 | 12 | 4 | 8 |
| 03/24/91 | 2.723 | | < 1 | | | 1 | | | | | | 7.3 | 7.2 | 12 | 12 | 12 | 17 |
| 03/25/91 | 2.312 | | < 1 | | | 1 | | | | | | 7.3 | 7.3 | 13 | 13 | 10 | 7 |
| 03/26/91 | 2.420 | | < 1 | | | 1 | | | | | | 7.2 | 7.3 | 14 | 16 | 8 | 7 |
| 03/27/91 | 2.572 | | < 1 | | | 1 | | | | | | 7.3 | 7.4 | 14 | 13 | 9 | 5 |
| 03/28/91 | 2.637 | | < 1 | | | 1 | | | | | | 7.4 | 7.2 | 13 | 13 | 9 | 5 |
| 04/04/91 | 2.139 | | 2 | | | 2 | | | | | | 7.3 | 7.1 | 13 | 13 | 10 | 21 |
| 04/10/91 | 2.196 | | < 1 | | | 1 | | | | | | 7.4 | 7.0 | 17 | 17 | 10 | 100 |
| 04/16/91 | 2.288 | | 48 | | | 48 | | | | | | 7.4 | 7.4 | 14 | 15 | 2 | 6 |
| 04/26/91 | 2.629 | | < 1 | | | 1 | | | | | | 7.2 | 6.7 | 16 | 16 | 11 | 14 |
| 05/02/91 | 2.350 | | < 1 | | | 1 | | | | | | 7.3 | 7.3 | 15 | 16 | 9 | 9 |
| 05/09/91 | 2.310 | | 11 | | | 11 | | | | | | 7.4 | 7.1 | 18 | 18 | 9 | 6 |
| 05/16/91 | 2.150 | | 67 | | | 67 | | | | | | 7.5 | 7.4 | 19 | 19 | 16 | 8 |
| 05/25/91 | 2.030 | | 20 | | | 20 | | | | | | 7.4 | 7.3 | 18 | 19 | 9 | 12 |
| 05/31/91 | 2.020 | | 120 | | | 120 | | | | | | 7.5 | 7.5 | 22 | 23 | 4 | 3 |
| 06/01/91 | | | 160 | | | 160 | | | | | | 7.2 | 7.1 | 19 | 20 | 2 | 7 |
| 06/09/91 | | | 33 | | | 33 | | | | | | 7.3 | 7.5 | 21 | 22 | < 0.1 | 11 |
| 06/20/91 | 1.900 | | 10 | | | 10 | | | | | | 7.4 | 7.3 | 21 | 22 | < 0.1 | 10 |
| 06/29/91 | 1.800 | | 42 | | | 42 | | | | | | 7.2 | 7.4 | 24 | 24 | 3 | 10 |
| 07/02/91 | 1.780 | | 47 | | | 47 | | | | | | 7.5 | 7.2 | 23 | 23 | 5 | 20 |
| 07/09/91 | 1.780 | | 46 | | | 46 | | | | | | 7.5 | 7.2 | 22 | 23 | 8 | 34 |
| 07/17/91 | 1.600 | | 25 | | | 25 | | | | | | 7.6 | 7.4 | 24 | 24 | 8 | 7 |
| 07/22/91 | 1.200 | | | | | | 4900 | < 2 | | | < 2 | 7.5 | 7.2 | 23 | 24 | 21 | 19 |
| 07/26/91 | 1.710 | | | | | | | | | | | 6.9 | 7.4 | 24 | 24 | 10 | 2 |
| 07/30/91 | 1.480 | 7,900 | < 2 | | | 2 | 1400 | < 2 | | | < 2 | 7.4 | 7.5 | 24 | 25 | 12 | 9 |
| 08/01/91 | 1.490 | | 8 | | | 8 | | | | | | 7.4 | 7.4 | 24 | 25 | 7 | 10 |
| 08/09/91 | 3.270 | | 89 | | | 89 | | | | | | 7.7 | 7.4 | 24 | 23 | 20 | 7 |
| 08/10/91 | 2.110 | | 44 | | | 44 | | | | | | 7.4 | 7.4 | 24 | 25 | 3 | 4 |
| 08/12/91 | 1.800 | >=240,000 | 49 | 3 | 1 | 18 | 54000 | < 2 2 | TNTC | 900 | 451 | 7.6 | 7.4 | 23 | 24 | 12 | 21 |
| 08/14/91 | 1.760 | 92,000 | 540 | 500 | 56 | 365 | 2200 | 16 | 170 | 93 | 93 | 7.6 | 7.6 | 23 | 24 | 12 | 15 |
| 08/16/91 | 1.880 | | 64 | | | 64 | | | | | | 7.6 | 7.4 | 23 | 24 | 6 | 16 |
| 08/19/91 | 3.140 | > 240,000 | 170 | 9 | 40 | 73 | 92000 | 110 | 26 | 26 | 54 | 7.3 | 6.7 | 24 | 24 | 4 | 5 |

PAGE 151

**TABLE 4-2. VERONA WASTEWATER TREATMENT PLANT
DAILY OPERATOR'S LOG DATA**

| DATE | TOTAL PLANT FLOW (MGD) | FECAL COLIFORM ORGANISMS | | | | | ENTEROCOCCI ORGANISMS | | | | | PLANT INFLUENT | | | | | |
|--|------------------------|-------------------------------|--------------------------|--------------------------|--------------------------|--|-----------------------------|--------------------|--------------------------|--------------------------|--------------------------------|-------------------|-------------------|--------------------|--------------------|-----------------------|-----------------------|
| | | UV INF (#/100 ml) | UV AND FINAL EFFLUENT | | | AVERAGE UV & FINAL EFFLUENT (#/100 ml) | UV INF. (#/100 ml) | UV EFFLUENT | | | AVERAGE UV EFFLUENT (#/100 ml) | PH (1) (S.U.) | PH (2) (S.U.) | TEMP. (1) (deg. C) | TEMP. (2) (deg. C) | SET. SOLIDS(1) (ML/L) | SET. SOLIDS(2) (ML/L) |
| | | | PLANT OUTFALL (#/100 ml) | INNER CHANNEL (#/100 ml) | OUTER CHANNEL (#/100 ml) | | | UV EFF. (#/100 ml) | INNER CHANNEL (#/100 ml) | OUTER CHANNEL (#/100 ml) | | | | | | | |
| 08/21/91 | 2,250 | 240,000 | < 2 | < 1 | < 1 | 1 | 4900 | 2 | < 1 | < 1 | 1 | 7.3 | 7.3 | 23 | 23 | 4 | 5 |
| 08/23/91 | 1,870 | | 100 | | | 100 | | | | | | 7.6 | 7.2 | 23 | 24 | 15 | 7 |
| 08/26/91 | 1,790 | 160,000 | 4 | 162 | 2 | 56 | 11000 | < 2 | < 1 | 55 | 19 | 7.4 | 7.3 | 23 | 24 | 15 | 11 |
| 08/28/91 | 1,790 | 25,500 | > 2,400 | 160 | TNTC | 1280 | 2000 | 350 | 201 | 287 | 279 | 7.4 | 7.3 | 23 | 24 | 15 | 13 |
| 09/04/91 | 1,840 | | | | | | | | 35 | 88 | 62 | 7.3 | 7.4 | 23 | 25 | 13 | 10 |
| 09/06/91 | 1,710 | | 151 | | | 151 | | | | | | 7.5 | 7.7 | 24 | 24 | 10 | 8 |
| 09/10/91 | 1,690 | | | 200 | 690 | 445 | | | 130 | 60 | 95 | 7.6 | 7.2 | 24 | 24 | 4 | 8 |
| 09/13/91 | 1,370 | | 120 | | | 120 | | | | | | 7.7 | 7.5 | 23 | 25 | 5 | 8 |
| 09/17/91 | 1,670 | | | 230 | 880 | 555 | | | 110 | 160 | 135 | 7.7 | 7.3 | 23 | 24 | 10 | 11 |
| 09/20/91 | 2,140 | | 52 | | | 52 | | | | | | 7.1 | 7.1 | 23 | 23 | 26 | 12 |
| 09/24/91 | 3,490 | | | 1 | < 1 | 1 | | | < 1 | < 1 | < 1 | 7.8 | 7.5 | 22 | 24 | 9 | 12 |
| 09/28/91 | 2,670 | | 5 | | | 5 | | | | | | 7.3 | 7.3 | 22 | 22 | 6 | 5 |
| 10/02/91 | 1,889 | | | < 1 | 7 | 4 | | | | | | | | | | | |
| 10/03/91 | 1,758 | | 9 | | | 9 | | | | | | | | | | | |
| 10/09/91 | 1,663 | | | 22 | 11 | 17 | | | 20 | < 1 | 10 | | | | | | |
| 10/10/91 | 1,668 | | 29 | | | 29 | | | | | | | | | | | |
| 10/15/91 | 1,891 | | | 10 | 4 | 7 | | | 24 | 18 | 21 | | | | | | |
| 10/17/91 | 1,582 | | 5 | | | 5 | | | | | | | | | | | |
| 10/22/91 | 1,511 | | | 470 | 550 | 510 | | | 210 | 260 | 235 | | | | | | |
| 10/25/91 | 1,541 | | 24 | | | 24 | | | | | | | | | | | |
| DESIGN VALUES: - MAX. 30 DAY - MAX 7 DAY | 5.0 7.0 | 30,000 50,000 | 200 400 | 200 400 | 200 400 | 200 400 | | | | | | | | | | | |
| MINIMUM MAXIMUM AVERAGE | 1.20 5.81 2.48 | 7900.00 240,000 143,629 | 0.2 2,400 43 | <1 500 138 | <1 880 173 | <1 1,280 42 | 1400.00 92,000 21,550 | <1 350 60 | <1 210 71 | < 1 900 150 | < 1 451 97 | 6.4 7.8 7.2 | 6.4 7.7 7.2 | 11 24 15 | 11 25 16 | 0 50 11 | 2 100 13 |

PAGE 152

TABLE 4-2. VERONA WASTEWATER TREATMENT PLANT
DAILY OPERATOR'S LOG DATA

| DATE | PLANT EFFLUENT | | | | | | | | NH3 (mg/l) | | TKN (mg/l) | | BOD (mg/l) | | S.S (mg/l) | | CBOD (mg/l) | | NBOD (mg/l) | | ALK.* (mg/l) | | COMMENTS |
|----------|----------------|-----|-------|-------|-------|-------|------|------|------------|------|------------|------|------------|------|------------|------|-------------|------|-------------|------|--------------|------|-------------------|
| | PH | PH | TEMP. | TEMP. | SET. | SET. | D.O. | D.O. | INF. | EFF. | INF. | EFF. | INF. | EFF. | INF. | EFF. | INF. | EFF. | INF. | EFF. | INF. | EFF. | |
| | (1) | (2) | (1) | (2) | (1) | (2) | (1) | (2) | | | | | | | | | | | | | | | |
| 01/09/91 | 7.4 | 7.2 | 7 | 8 | < 0.1 | < 0.1 | 12.0 | | | | | | | | 11 | | | | | | | 62 | UV System On-Line |
| 01/10/91 | 6.8 | 6.2 | 8 | 8 | < 0.1 | < 0.1 | 10.6 | | | | | | | 1 | | | | | | | | 89 | |
| 01/11/91 | | | 8 | 8 | < 0.1 | < 0.1 | 9.8 | | | | | 175 | 4 | | | | | | | | | 99 | |
| 01/12/91 | 7.2 | 6.0 | 9 | | < 0.1 | < 0.1 | 9.8 | 9.8 | | | | | | | | | | | | | | 109 | |
| 01/13/91 | 6.9 | 6.8 | 9 | | < 0.1 | < 0.1 | 9.3 | | | | | | | | | | | | | | | 101 | |
| 01/14/91 | 6.4 | 6.9 | 10 | 10 | < 0.1 | < 0.1 | 10.2 | 10.0 | | | | | | < 1 | | | | | | | | 114 | |
| 01/15/91 | 7.1 | 7.5 | 10 | 11 | < 0.1 | < 0.1 | 9.8 | 9.5 | | | | | | | | | | | | | | 112 | |
| 01/16/91 | 6.8 | 7.3 | 12 | 12 | < 0.1 | < 0.1 | 8.9 | 8.5 | | | | | | | | | | | | | | 60 | |
| 01/17/91 | 6.9 | | 13 | | < 0.1 | < 0.1 | 8.4 | | | | | | | < 1 | | | | | | | | 97 | |
| 01/18/91 | 7.4 | 8.7 | 13 | 12 | < 0.1 | < 0.1 | 8.7 | 8.4 | | | | | | | | | | | | | | 97 | |
| 01/19/91 | 7.9 | 8.1 | 10 | 10 | < 0.1 | < 0.1 | 8.7 | 8.7 | | | | 94 | 1 | 184 | 10 | | | | | | | 105 | |
| 01/20/91 | 8.4 | 8.1 | 11 | 11 | < 0.1 | < 0.1 | 9.9 | 9.7 | | | | | | | | | | | | | | 97 | |
| 01/21/91 | 7.8 | | 14 | | < 0.1 | < 0.1 | 8.9 | | | | | | | | | | | | | | | 90 | |
| 01/22/91 | 7.4 | 7.1 | 11 | 11 | < 0.1 | < 0.1 | 9.2 | 9.2 | | | | | | | | | | | | | | 95 | |
| 01/23/91 | 7.3 | 7.4 | 12 | 11 | < 0.1 | < 0.1 | 9.1 | 9.2 | | | | | | | | | | | | | | 145 | |
| 01/24/91 | 7.4 | 7.2 | 10 | 9 | < 0.1 | < 0.1 | 9.2 | 9.2 | | | | | | | | | | | | | | 107 | |
| 01/25/91 | 7.2 | 7.4 | 10 | 9 | < 0.1 | < 0.1 | 9.0 | 9.3 | | | | 130 | 4 | | | | | | | | | 97 | |
| 01/26/91 | 7.4 | 7.3 | 7 | 8 | < 0.1 | < 0.1 | 8.9 | 9.2 | | | | | | | | | | | | | | 98 | |
| 01/27/91 | 7.4 | 7.2 | 9 | 10 | < 0.1 | < 0.1 | 9.0 | 9.2 | | | | | | | | | | | | | | 101 | |
| 01/28/91 | 7.4 | 7.2 | 11 | 11 | < 0.1 | < 0.1 | 9.2 | 9.2 | | | | | | | | | | | | | | 105 | |
| 01/29/91 | 7.2 | 7.2 | 9 | 12 | < 0.1 | < 0.1 | 9.0 | 9.2 | | | | | | | | | | | | | | 102 | |
| 02/01/91 | 6.9 | 7.4 | 9 | 9 | < 0.1 | < 0.1 | 9.1 | 8.9 | 17.4 | 0.48 | | 135 | 4 | 228 | 1 | 208 | 2 | 287 | 3 | | | 93 | |
| 02/02/91 | 6.6 | 6.2 | 11 | 11 | < 0.1 | < 0.1 | 8.2 | 9.2 | 21.0 | 0.36 | | | | | | | | | | | | 111 | |
| 02/03/91 | 7.3 | 7.4 | 11 | 11 | < 0.1 | < 0.1 | 8.1 | 9.1 | 23.1 | 0.50 | | | | | | | | | | | | 110 | |
| 02/04/91 | 7.4 | 7.2 | 11 | 10 | < 0.1 | < 0.1 | 9.6 | 8.0 | 21.0 | 0.72 | | | | | | | | | | | | 102 | |
| 02/05/91 | 7.1 | 7.2 | 11 | 11 | < 0.1 | < 0.1 | 9.0 | 8.6 | 23.0 | 0.60 | | | | | | | | | | | | 94 | |
| 02/06/91 | 7.2 | 7.3 | 12 | 12 | < 0.1 | < 0.1 | 8.4 | 8.0 | 24.0 | 0.72 | | | | | | | | | | | | 79 | |
| 02/07/91 | 6.7 | 7.3 | 11 | 11 | < 0.1 | < 0.1 | 7.8 | 8.0 | | 0.48 | | | | 198 | 2 | | | | | | | 57 | |
| 02/08/91 | 6.5 | 7.3 | 11 | 11 | < 0.1 | < 0.1 | 8.2 | 8.3 | | 0.30 | | | | | | | | | | | | 80 | |
| 02/09/91 | 7.4 | 7.0 | 11 | 11 | < 0.1 | < 0.1 | 8.3 | 8.3 | | 0.36 | | 189 | 2 | | | 277 | 6 | 159 | < 1 | | | 114 | |
| 02/10/91 | 7.3 | 7.2 | 11 | 11 | < 0.1 | < 0.1 | 7.9 | 8.4 | | 0.30 | | | | | | | | | | | | 106 | |
| 02/11/91 | 7.2 | 7.3 | 11 | 12 | < 0.1 | < 0.1 | 8.5 | 8.7 | | 0.48 | | | | | | | | | | | | 121 | |
| 02/12/91 | 6.8 | 6.2 | 11 | 10 | < 0.1 | < 0.1 | 7.9 | 8.3 | | 0.48 | | | | | | | | | | | | 102 | |
| 02/13/91 | 6.6 | 6.6 | 10 | 11 | < 0.1 | < 0.1 | 8.6 | 7.8 | | | | | | | | | | | | | | 114 | |
| 02/14/91 | 6.4 | 7.2 | 11 | 12 | < 0.1 | < 0.1 | 8.8 | 7.9 | | | | | | 238 | 6 | | | | | | | 104 | |
| 02/15/91 | 6.2 | 6.7 | 10 | 11 | < 0.1 | < 0.1 | 8.2 | 8.7 | | | | 178 | 4 | | | | | | | | | 97 | |
| 02/16/91 | 7.3 | 7.3 | 10 | 10 | < 0.1 | < 0.1 | 8.5 | 8.3 | | | | | | | | | | | | | | | |
| 02/17/91 | 7.2 | 7.3 | 10 | 10 | < 0.1 | < 0.1 | 8.7 | 8.3 | | | | | | | | | | | | | | | |
| 02/18/91 | 7.2 | 7.1 | 10 | 10 | < 0.1 | < 0.1 | 7.8 | 7.5 | | | | | | | | | | | | | | | |
| 02/19/91 | 7.4 | 7.3 | 11 | 11 | < 0.1 | < 0.1 | 8.5 | 8.3 | | | | | | | | | | | | | | | |
| 02/20/91 | 7.3 | 7.4 | 12 | 12 | < 0.1 | < 0.1 | 7.8 | 8.6 | | | | | | | | | | | | | | 112 | |
| 02/21/91 | 7.3 | 7.3 | 11 | 11 | < 0.1 | < 0.1 | 7.8 | 8.1 | | | | | | | | | | | | | | 108 | |
| 02/22/91 | 7.2 | 6.9 | 12 | 12 | < 0.1 | < 0.1 | 8.2 | | | | | | | | | | | | | | | 99 | |
| 02/23/91 | 7.1 | 7.1 | 10 | 10 | < 0.1 | < 0.1 | | 6.5 | | 0.20 | | 99 | 1 | 178 | 2 | | | | | | | 93 | |
| 02/24/91 | 7.2 | 6.9 | 10 | 11 | < 0.1 | < 0.1 | 6.0 | 6.2 | | | | | | | | | | | | | | 85 | |
| 02/25/91 | 7.3 | 7.3 | 11 | 11 | < 0.1 | < 0.1 | 8.5 | 7.8 | | | | | | | | | | | | | | 90 | |
| 02/26/91 | 6.4 | 6.4 | 10 | 11 | < 0.1 | < 0.1 | 7.9 | 7.8 | | | | | | | | | | | | | | 80 | |
| 02/27/91 | 6.4 | 6.4 | 11 | 11 | < 0.1 | < 0.1 | 7.2 | 7.9 | | 0.65 | | | | | | | | | | | | 85 | |
| 02/28/91 | 6.2 | 7.0 | 11 | 11 | < 0.1 | < 0.1 | 8.3 | 8.6 | | | | | | | 6 | | | | | | | 81 | |
| 03/01/91 | 7.0 | 7.0 | 11 | 12 | < 0.1 | < 0.1 | 8.6 | 7.9 | | | | | | | | | | | | | | 70 | |
| | | | | | | | | | | | | | | | | | | | | | | 106 | |

PAGE 153

**TABLE 4-2. VERONA WASTEWATER TREATMENT PLANT
DAILY OPERATOR'S LOG DATA**

| DATE | PLANT EFFLUENT | | | | | | | | NH3 (mg/l) | | TKN (mg/l) | | BOD (mg/l) | | S.S. (mg/l) | | CBOD (mg/l) | | NBOD (mg/l) | | ALK.* (mg/l) | | COMMENTS | |
|----------|----------------|-----|-------|-------|-------|-------|------|------|------------|------|------------|------|------------|------|-------------|------|-------------|------|-------------|-------|--------------|------|-------------------------|--|
| | PH | PH | TEMP. | TEMP. | SET. | SET. | D.O. | D.O. | INF. | EFF. | INF. | EFF. | INF. | EFF. | INF. | EFF. | INF. | EFF. | INF. | EFF. | INF. | EFF. | | |
| | (1) | (2) | (1) | (2) | (1) | (2) | (1) | (2) | | | | | | | | | | | | | | | | |
| 03/02/91 | 7.1 | 7.1 | 12 | 12 | < 0.1 | < 0.1 | 7.8 | 7.9 | | | | | | | | | | | | | 130 | 76 | | |
| 03/03/91 | 6.9 | 6.9 | 13 | 13 | < 0.1 | < 0.1 | 7.5 | 7.7 | | | | | | | | | | | | | 130 | 82 | | |
| 03/05/91 | 7.2 | 7.1 | 11 | 11 | < 0.1 | < 0.1 | 9.3 | 8.6 | | 0.48 | | | | | | | | | | | 101 | 83 | | |
| 03/06/91 | 7.1 | 7.1 | 11 | 12 | < 0.1 | < 0.1 | 8.3 | 8.0 | | | | | | | | | | | | | 107 | 90 | | |
| 03/07/91 | 7.3 | 7.1 | 12 | 12 | < 0.1 | < 0.1 | 8.4 | 7.7 | | | | | 220 | 1 | | | | | | | 111 | 99 | | |
| 03/08/91 | 6.2 | 7.1 | 11 | 11 | < 0.1 | < 0.1 | 8.4 | 8.2 | | | | | 136 | 4 | | | 244 | 7 | 656 | 4 | 114 | 98 | | |
| 03/11/91 | 6.2 | 6.4 | 10 | 11 | < 0.1 | < 0.1 | 7.9 | 8.2 | | | | | | | | | | | | | 122 | 81 | | |
| 03/12/91 | 7.1 | 7.0 | 10 | 10 | < 0.1 | < 0.1 | 7.9 | 8.7 | | | | | | | | | | | | | 127 | 81 | | |
| 03/13/91 | 7.1 | 7.2 | 11 | 11 | < 0.1 | < 0.1 | 8.6 | 8.0 | | 0.40 | | | | | | | | | | | 136 | 59 | | |
| 03/14/91 | 6.4 | 6.2 | 11 | 11 | < 0.1 | < 0.1 | 8.2 | 8.0 | | | | | 728 | 6 | | | | | | | 130 | 45 | | |
| 03/15/91 | 6.3 | 6.1 | 11 | 12 | < 0.1 | < 0.1 | 8.2 | 8.6 | | | | | 162 | 7 | | | 275 | 9 | 292 | 3 | 146 | 40 | | |
| 03/16/91 | 6.2 | 6.3 | 11 | 12 | < 0.1 | < 0.1 | 8.2 | 8.6 | | | | | | | | | | | | | 108 | 40 | | |
| 03/17/91 | 6.2 | 6.3 | 12 | 12 | < 0.1 | < 0.1 | 8.6 | 8.6 | | | | | | | | | | | | | 136 | 41 | | |
| 03/18/91 | 7.0 | 7.0 | 12 | 12 | < 0.1 | < 0.1 | 8.3 | 8.2 | | | | | | | | | | | | | 130 | 64 | | |
| 03/19/91 | 7.1 | 7.0 | 12 | 11 | < 0.1 | < 0.1 | 7.7 | 8.6 | | | | | | | | | | | | | 127 | 64 | | |
| 03/20/91 | 7.1 | 7.2 | 11 | 12 | < 0.1 | < 0.1 | 8.6 | 8.6 | | | | | | | | | | | | | 127 | 62 | | |
| 03/21/91 | 7.2 | 7.3 | 11 | 12 | < 0.1 | < 0.1 | 8.4 | 8.2 | | 0.85 | | | 830 | 1 | | | | | | | 150 | 64 | | |
| 03/22/91 | 7.2 | 7.3 | 11 | 12 | < 0.1 | < 0.1 | 7.9 | 8.2 | | | | | 252 | 2 | | | 298 | 4 | 102 | 2 | 119 | 67 | | |
| 03/23/91 | 7.3 | 7.3 | 11 | 11 | < 0.1 | < 0.1 | 8.6 | 8.0 | | | | | | | | | | | | | 124 | 81 | | |
| 03/24/91 | 7.4 | 7.3 | 11 | 11 | < 0.1 | < 0.1 | 8.2 | 8.0 | | | | | | | | | | | | | 118 | 89 | | |
| 03/25/91 | 6.7 | 6.7 | 11 | 12 | < 0.1 | < 0.1 | 8.6 | 8.3 | | | | | | | | | | | | | 116 | 88 | | |
| 03/26/91 | 6.4 | 6.4 | 13 | 15 | < 0.1 | < 0.1 | 8.9 | | | | | | | | | | | | | | 107 | 84 | | |
| 03/27/91 | 7.3 | 6.4 | 13 | 12 | < 0.1 | < 0.1 | 8.8 | | | 0.63 | | | | | | | | | | | 111 | 80 | | |
| 03/28/91 | 6.5 | 6.2 | 12 | 12 | < 0.1 | < 0.1 | 8.6 | | | | | | 206 | 3 | 130 | 1 | | | | | 114 | 78 | | |
| 04/04/91 | 7.2 | 7.4 | 12 | 12 | < 0.1 | < 0.1 | 8.7 | 8.3 | | | | | 80 | 1 | | | | | | | 138 | 73 | | |
| 04/10/91 | 7.2 | 7.4 | 17 | 18 | < 0.1 | < 0.1 | 8.6 | 8.6 | | | | | | | | | | | | | 177 | 52 | | |
| 04/18/91 | 7.3 | 7.5 | 14 | 15 | < 0.1 | < 0.1 | 8.7 | 7.7 | | | | | | | 111 | 2 | | | | | 134 | 83 | | |
| 04/26/91 | 6.8 | 7.3 | 15 | 16 | < 0.1 | < 0.1 | 8.6 | 8.1 | | | 63.6 | 0.43 | 118 | 2 | | | 130 | 2 | 291 | 2 | 113 | 73 | | |
| 05/02/91 | 7.5 | 7.8 | 17 | 18 | < 0.1 | < 0.1 | 8.4 | 8.2 | | | | | | | 108 | 4 | | | | | 127 | 76 | | |
| 05/09/91 | 7.0 | 7.2 | 16 | 18 | < 0.1 | < 0.1 | 8.2 | 8.0 | | | | | | | 312 | 6 | | | | | 116 | 75 | | |
| 05/16/91 | 7.2 | 7.1 | 20 | 20 | < 0.1 | < 0.1 | 7.7 | 7.7 | | 0.13 | | | | | 340 | 4 | | | | | 132 | 71 | | |
| 05/25/91 | 7.2 | 7.3 | 19 | 19 | < 0.1 | < 0.1 | 8.1 | 8.0 | | | | | | | | | | | | | 123 | 81 | | |
| 05/31/91 | 7.2 | 7.1 | 23 | 23 | < 0.1 | < 0.1 | 7.8 | 7.7 | | | | | 257 | 6 | 950 | 8 | | | | | 135 | 66 | | |
| 06/01/91 | 7.3 | 7.3 | 22 | 23 | < 0.1 | < 0.1 | 8.0 | 8.1 | | | | | | | | | | | | | | | | |
| 06/09/91 | 6.9 | 7.0 | 21 | 21 | < 0.1 | < 0.1 | 6.7 | 7.9 | | | | | | | | | | | | | 72 | 138 | | |
| 06/20/91 | 7.4 | 7.3 | 22 | 21 | < 0.1 | < 0.1 | 7.7 | 7.4 | 16.9 | 0.70 | 88.5 | 2.82 | | | | | | | 313.04 | 12.89 | 122 | 78 | | |
| 06/29/91 | 7.0 | 7.0 | 24 | 24 | < 0.1 | < 0.1 | 7.9 | 7.8 | | | | | | | | | | | | | 140 | 78 | | |
| 07/02/91 | 7.6 | 7.6 | 23 | 23 | < 0.1 | < 0.1 | 7.8 | 7.4 | 22.8 | | | | | | | | | | | | 132 | 146 | | |
| 07/09/91 | 7.4 | 7.1 | 23 | 24 | 0.1 | < 0.1 | 7.8 | 7.5 | | | | | | | | | | | | | 74 | 148 | | |
| 07/17/91 | 7.4 | 7.4 | 24 | 24 | < 0.1 | < 0.1 | 7.4 | 7.3 | | 0.14 | | 0.38 | | | | | | | | 1.74 | 70 | 144 | | |
| 07/22/91 | 7.1 | 7.1 | 24 | 24 | < 0.1 | < 0.1 | 8.1 | 7.8 | | | | | | | | | | | | | 188 | 28 | | |
| 07/26/91 | 7.4 | 7.4 | 24 | 24 | < 0.1 | < 0.1 | 7.4 | 7.4 | 21.0 | 0.32 | | 0.52 | 205 | 1 | | | 270 | 3 | | 2.38 | 169 | 6.2 | | |
| 07/30/91 | 7.4 | 7.3 | 23 | 25 | < 0.1 | < 0.1 | 7.5 | 7.3 | | | | | | | | | | | | | 137 | 77 | | |
| 08/01/91 | 7.6 | 7.2 | 24 | 24 | < 0.1 | < 0.1 | 6.7 | 7.5 | 23.0 | 0.06 | 48.75 | 0.11 | | | 608 | 2 | | | 223 | 0.5 | 142 | 83 | | |
| 08/09/91 | 7.6 | 7.4 | 24 | 24 | < 0.1 | < 0.1 | 7.3 | 7.9 | | | | | 180 | 2 | | | 278 | 2 | | | 149 | 86 | | |
| 08/10/91 | 7.4 | 7.6 | 24 | 24 | < 0.1 | < 0.1 | 7.9 | 7.9 | | | | | | | | | | | | | 127 | 81 | | |
| 08/12/91 | 7.8 | 7.7 | 24 | 25 | < 0.1 | < 0.1 | 7.3 | 7.5 | | | | | | | | | | | | | 148 | 96 | Split Samples w/ KA Lab | |
| 08/14/91 | 7.7 | 7.7 | 24 | 24 | < 0.1 | < 0.1 | 7.8 | 7.5 | | | | | | | | | | | | | 154 | 90 | Split Samples w/ KA Lab | |
| 08/16/91 | 7.6 | 7.4 | 24 | 24 | < 0.1 | < 0.1 | 7.8 | 7.2 | | | | | | | | | 236 | 2 | | | 158 | 78 | | |
| 08/19/91 | 7.4 | 7.3 | 24 | 24 | < 0.1 | < 0.1 | 7.4 | 7.5 | | | | | | | | | | | | | 104 | 72 | Split Samples w/ KA Lab | |

PAGE 154

**TABLE 4-2. VERONA WASTEWATER TREATMENT PLANT
DAILY OPERATOR'S LOG DATA**

| DATE | PLANT EFFLUENT | | | | | | | | NH3 (mg/l) | | TKN (mg/l) | | BOD (mg/l) | | S S (mg/l) | | CBOD (mg/l) | | NBOD (mg/l) | | ALK.* (mg/l) | | COMMENTS |
|---|----------------|-----|-------|-------|-------|-------|------|------|------------|------|------------|------|------------|------|------------|------|-------------|------|-------------|------|--------------|------|-------------------------|
| | PH | PH | TEMP. | TEMP. | SET. | SET. | D.O. | D.O. | INF. | EFF. | INF. | EFF. | INF. | EFF. | INF. | EFF. | INF. | EFF. | INF. | EFF. | INF. | EFF. | |
| | (1) | (2) | (1) | (2) | (1) | (2) | (1) | (2) | | | | | | | | | | | | | | | |
| 08/21/91 | 7.4 | 7.5 | 23 | 23 | <0.1 | <0.1 | 7.8 | 7.8 | | | | | | | | | | | | | 120 | 71 | Split Samples w/ KA Lab |
| 08/23/91 | 7.5 | 7.6 | 24 | 24 | <0.1 | <0.1 | 7.4 | 7.2 | | | 188 | 1 | | | 255 | 3 | | | | | 149 | 80 | |
| 08/26/91 | 7.3 | 7.2 | 23 | 23 | <0.1 | <0.1 | 6.7 | 7.3 | | | | | 142 | 3 | | | | | | | 152 | 87 | |
| 08/28/91 | 7.4 | 7.3 | 24 | 24 | <0.1 | <0.1 | 6.6 | 7.0 | | | | | | | | | | | | | 147 | 78 | |
| 08/04/91 | 7.6 | 7.6 | 23 | 23 | <0.1 | <0.1 | 7.9 | 7.7 | 17.5 | 0.10 | 36.25 | 0.84 | | | | | 188 | 2.92 | | | 185 | 84 | |
| 09/06/91 | 7.6 | 7.5 | 23 | 24 | <0.1 | <0.1 | 7.8 | 7.5 | | | 184 | 1 | 227 | 1 | 315 | 2 | | | | | 154 | 70 | |
| 09/10/91 | 7.4 | 7.6 | 24 | 24 | <0.1 | <0.1 | 7.1 | 7.2 | | | | | | | | | | | | | 154 | 72 | |
| 09/13/91 | 7.6 | 7.6 | 23 | 24 | <0.1 | <0.1 | 7.5 | 7.5 | | | | | | | | | | | | | 149 | 68 | |
| 09/17/91 | 7.5 | 7.4 | 24 | 24 | <0.1 | <0.1 | 7.2 | 7.1 | | | | | | | | | | | | | 145 | 70 | |
| 09/20/91 | 7.6 | 7.5 | 22 | 23 | <0.1 | <0.1 | 7.4 | 7.8 | | | | | | | | | | | | | 163 | 76 | |
| 09/24/91 | 7.9 | 7.7 | 22 | 22 | <0.1 | <0.1 | 7.9 | 7.9 | | | | | | | | | | | | | 166 | 73 | |
| 09/26/91 | 7.5 | 7.5 | 22 | 21 | <0.1 | <0.1 | 7.7 | 7.6 | | | | | | | | | | | | | 109 | 73 | |
| 10/02/91 | 7.5 | 7.5 | 22 | 22 | <0.1 | <0.1 | 7.7 | 7.4 | | 0.13 | | 0.32 | 2 | 2 | | 4 | | 1.48 | | | | 69 | |
| 10/03/91 | 7.6 | 7.2 | 22 | 22 | <0.1 | <0.1 | 7.6 | 7.4 | | | | | | | | | | | | | | 68 | |
| 10/09/91 | 7.7 | 7.6 | 19 | 19 | <0.1 | <0.1 | 7.8 | 8.2 | | 0.20 | | 0.2 | 3 | | | 4 | | 0.91 | | | | 86 | |
| 10/10/91 | 7.8 | 7.6 | 19 | 20 | <0.1 | <0.1 | 8.5 | 8.1 | | | | | | 6 | | | | | | | | 76 | |
| 10/15/91 | 7.6 | 7.7 | 18 | 19 | <0.1 | <0.1 | 8.4 | 8.5 | | | | | | | | | | | | | | 63 | |
| 10/17/91 | 7.1 | 7.3 | 18 | 18 | <0.1 | <0.1 | 8.2 | 8.2 | | | | | | | | | | | | | | 54 | |
| 10/22/91 | 7.3 | 7.4 | 17 | 18 | <0.1 | <0.1 | 7.6 | 8.0 | | 0.40 | | 0.52 | | 6 | | | | 2.38 | | | | 64 | |
| 10/25/91 | 7.1 | 7.5 | 20 | 20 | <0.1 | <0.1 | 7.0 | 7.9 | | | | | | | | | | | | | | 77 | |
| DESIGN VALUES: - MAX. 30 DAY - MAX. 7 DAY | | | | | | | | | | | | | | | | | | | | | | | |
| MINIMUM | 6.2 | 6.0 | 7 | 8 | < 0.1 | < 0.1 | 6.0 | 6.2 | 16.9 | 0.06 | 36.3 | 0.11 | 94 | 1.0 | 80 | 0.0 | 130 | 2.0 | 102 | 0.0 | 60 | 6 | |
| MAXIMUM | 8.4 | 8.7 | 24 | 25 | 0.1 | < 0.1 | 12.0 | 10.0 | 24.0 | 0.85 | 68.5 | 2.82 | 257 | 7.0 | 950 | 11.0 | 315 | 9.0 | 656 | 12.9 | 188 | 216 | |
| AVERAGE | 7.2 | 7.2 | 15 | 15 | < 0.1 | < 0.1 | 8.3 | 8.1 | 21.0 | 0.41 | 54.3 | 0.66 | 169 | 2.8 | 323 | 3.6 | 253 | 3.8 | 277 | 2.8 | 124 | 87 | |

- NOTES:
 1) Plant effluent values are sampled at plant discharge point (Outfall 004).
 2) Inner and outer channel samples are taken in the respective UV channels after disinfection; therefore, theoretically should be equivalent to the plant effluent values taken at Outfall 004.
 3) The final effluent average value is the average of the plant effluent, inner channel and outer channel values. This average value was the final effluent fecal coliform and enterococci value used in all graphs.

APPENDIX F

VERONA WWTP - GRAPHS

Figure 4-1. Verona WWTP Eff. Fecal Coliform Vs. Flow

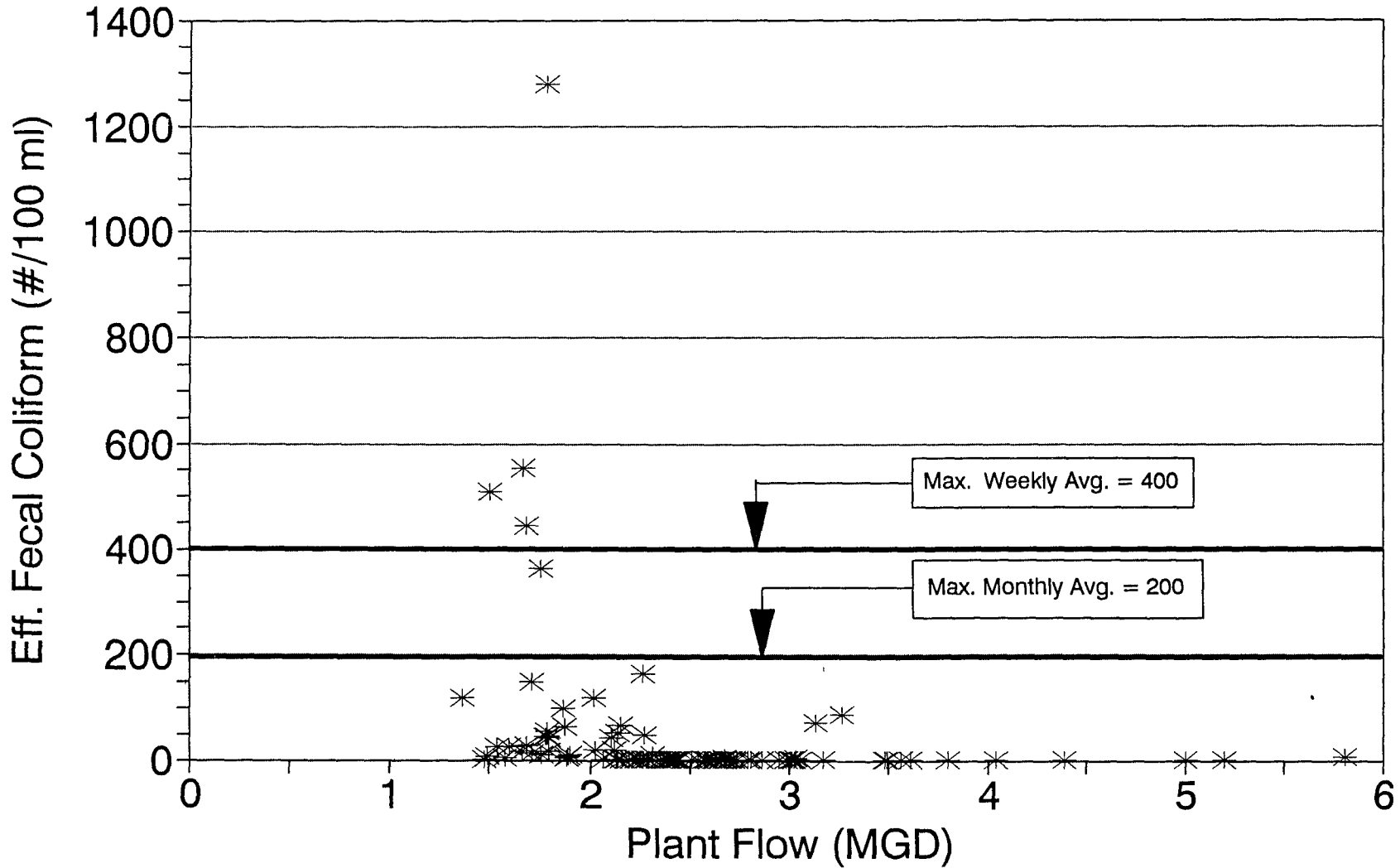

Figure 4-2. Verona WWTP Eff Fecal Col. Vs. Eff Suspended Solids

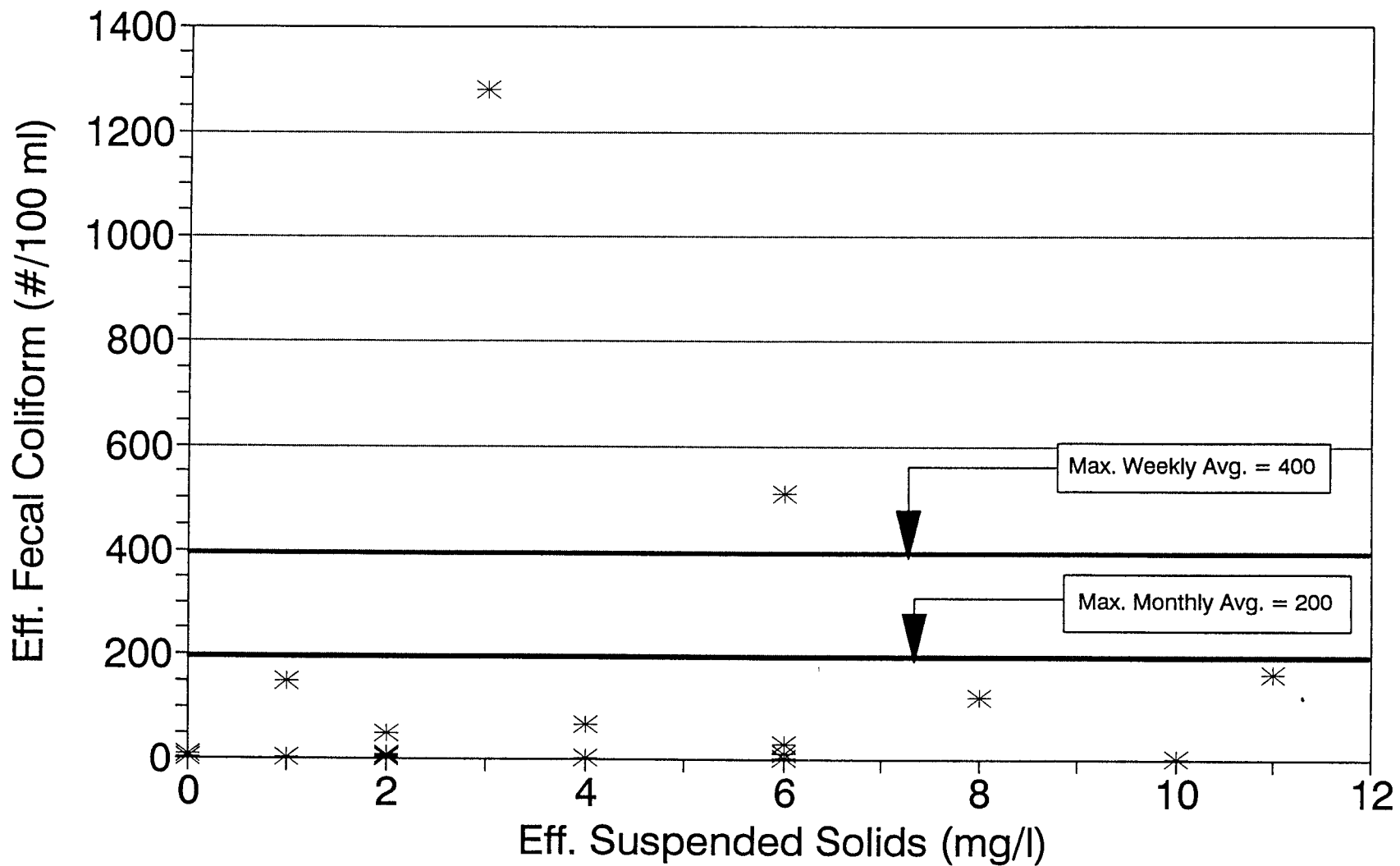

Figure 4-3. Verona WWTP Eff. Fecal Coliform Vs. Eff. Temp.

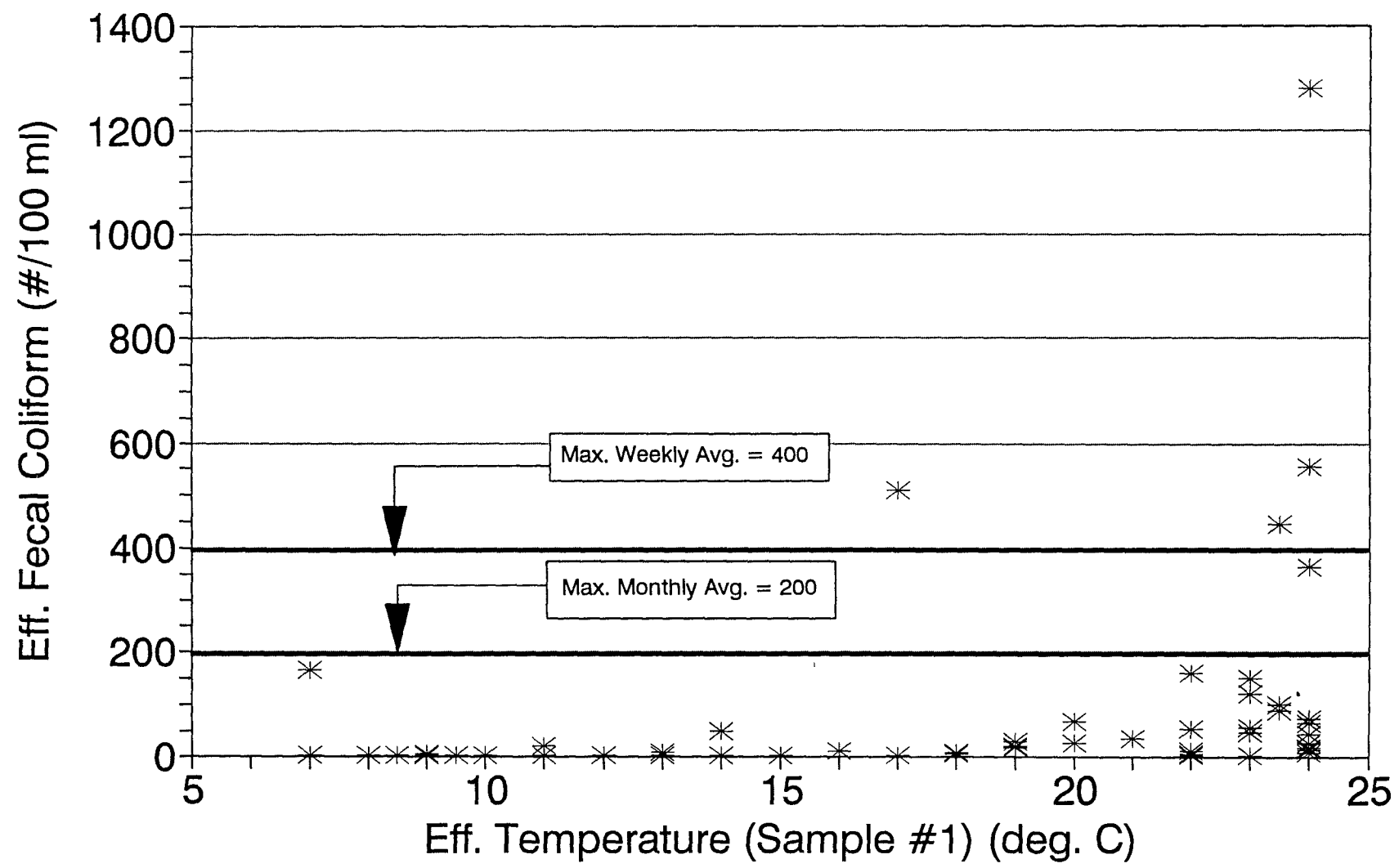

Figure 4-4. Verona WWTP Eff. Fecal Coliform Vs. Eff. pH

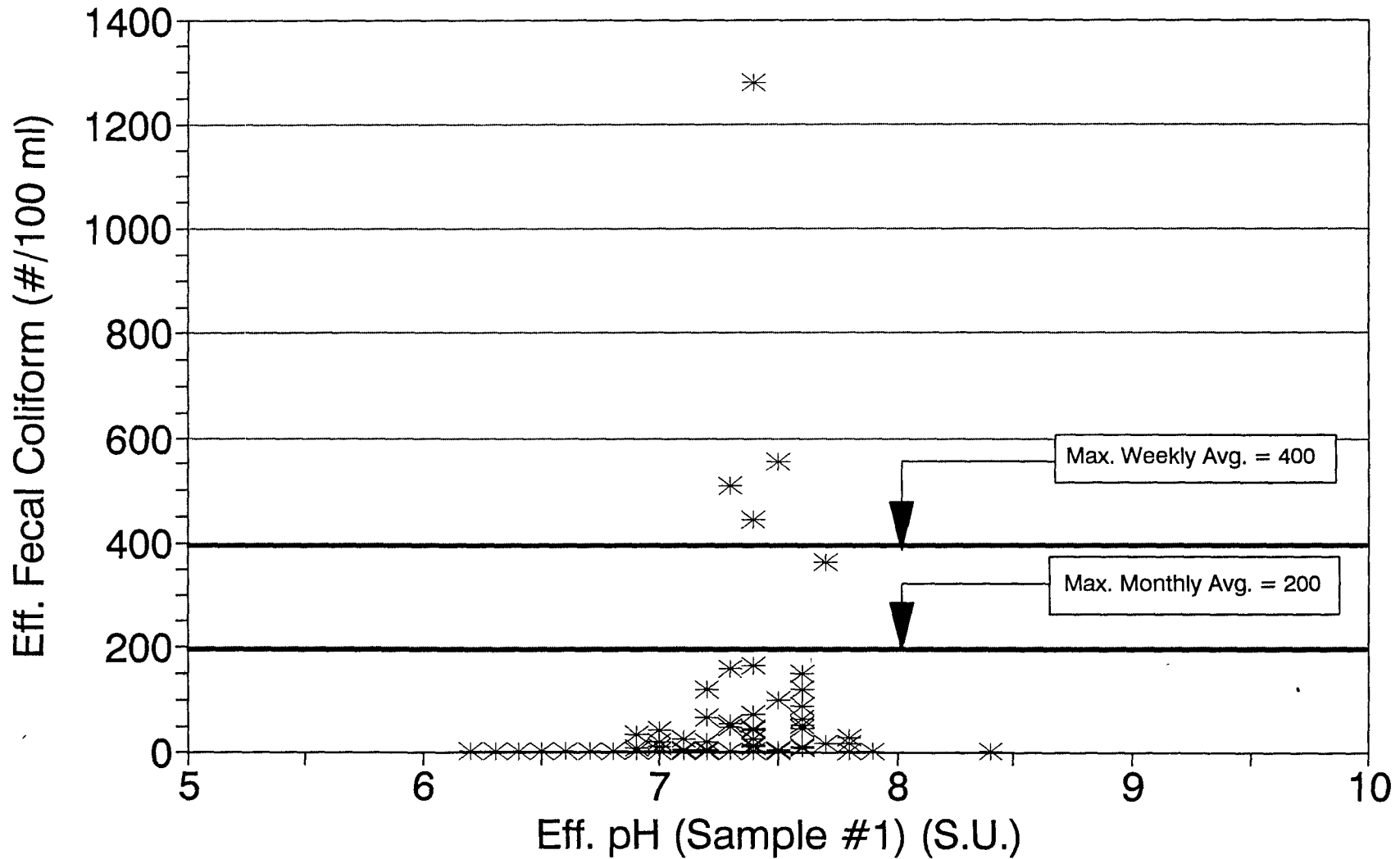

Figure 4-5. Verona WWTP
Eff. Fecal Coliform Vs. Eff. BOD

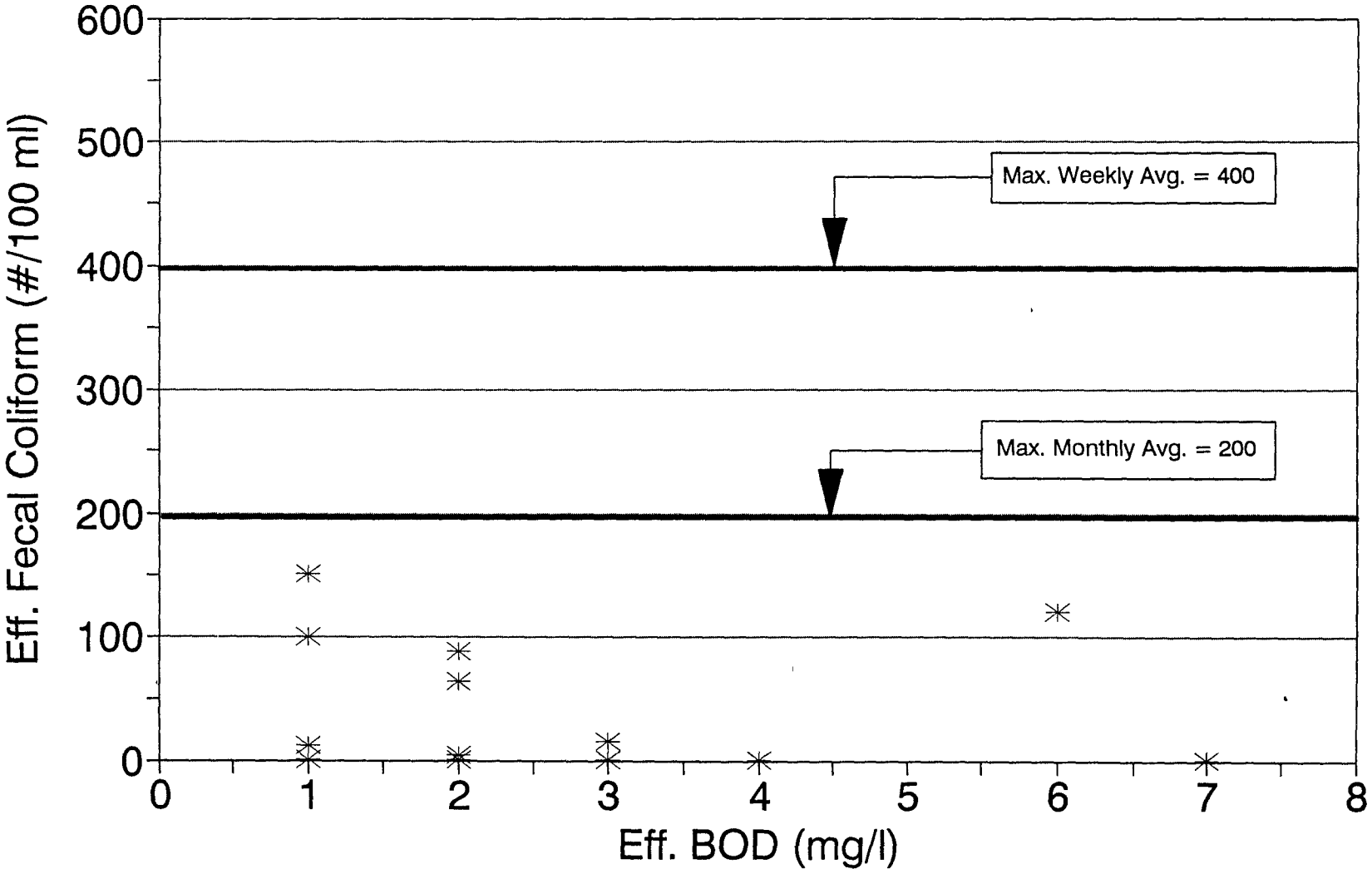

Figure 4-6. Verona WWTP
Eff. Fecal Coliform Vs. Eff. CBOD

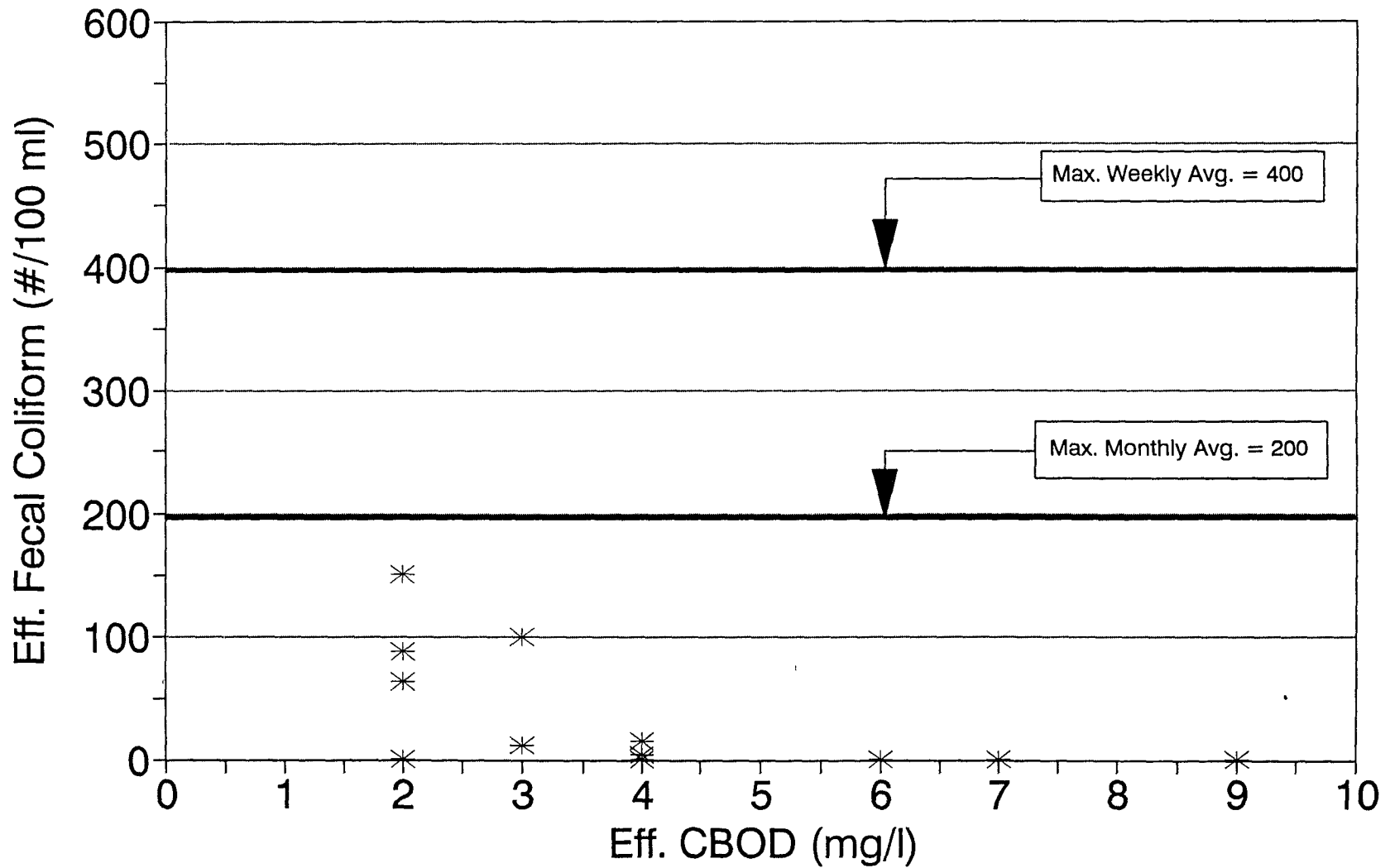

Figure 4-7. Verona WWTP Eff. Fecal Coliform Vs. Eff. NBOD

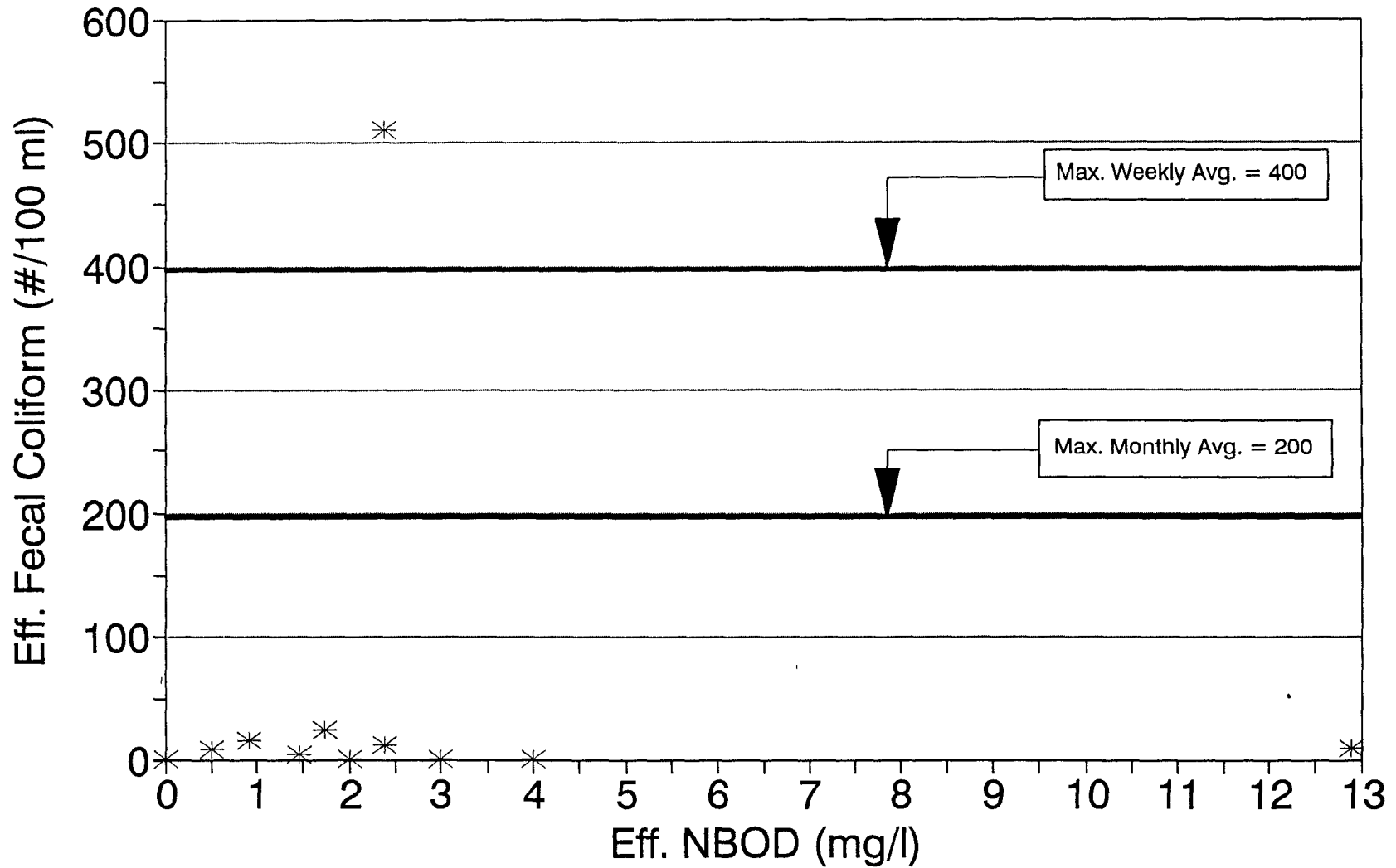

Figure 4-8. Verona WWTP Eff Fecal Col. Vs. Eff Dissolved Oxygen

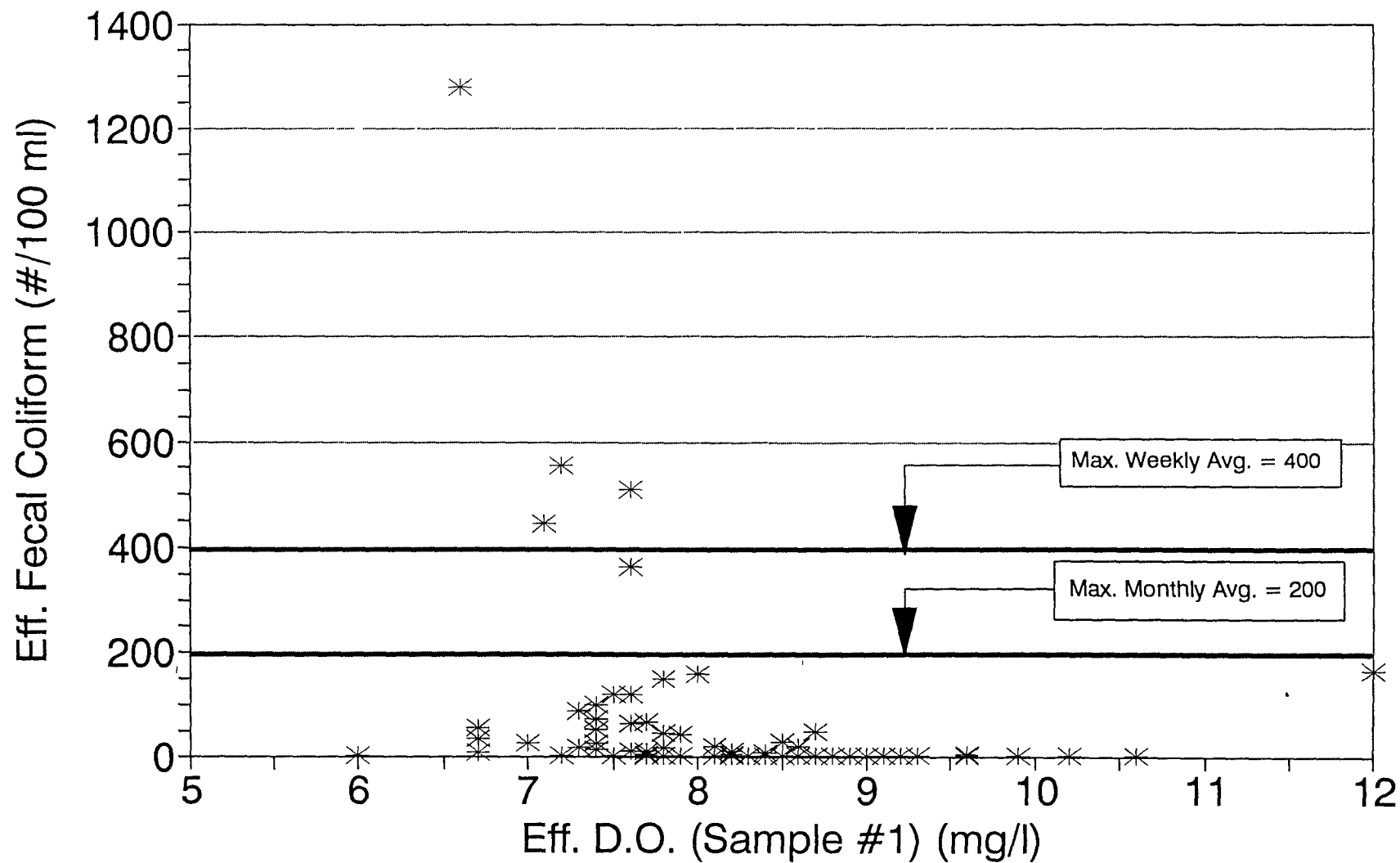

Figure 4-9. Verona WWTP Eff Fecal Col. Vs. Eff. Alkalinity

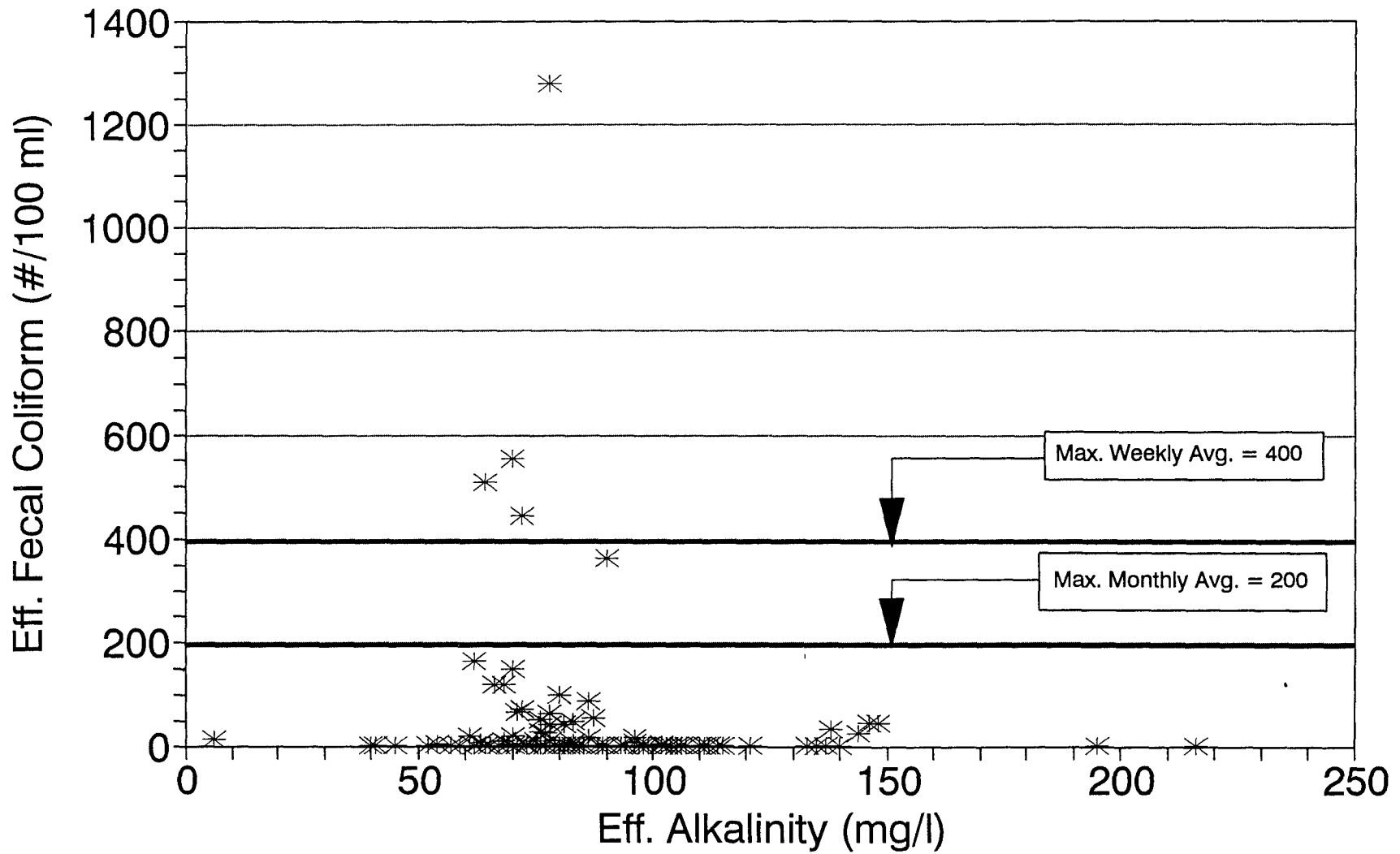

Figure 4-10. Verona WWTP Eff. Enterococci Vs. Flow

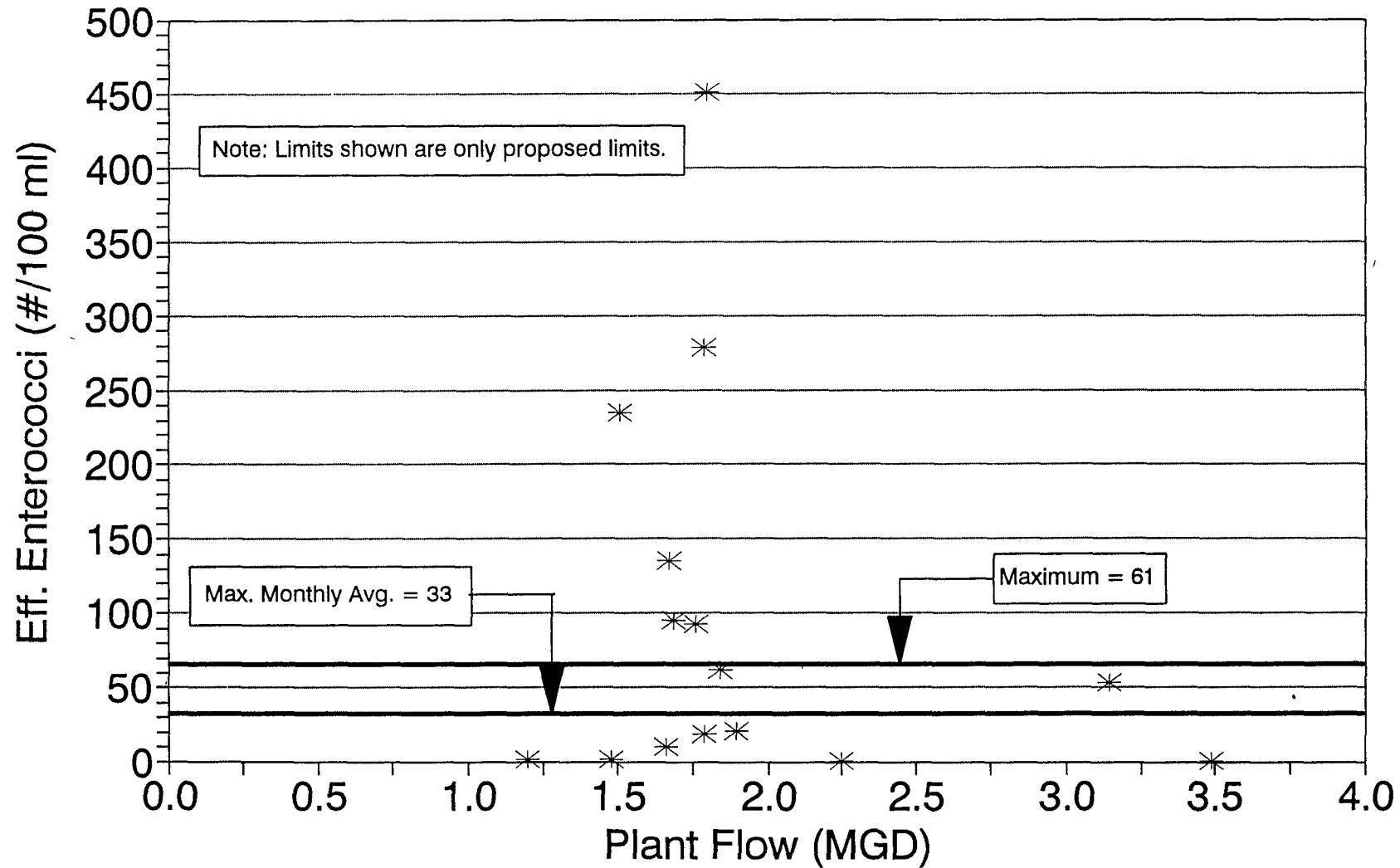

Figure 4-11. Verona WWTP Eff. Enterococci Vs. Suspended Solids

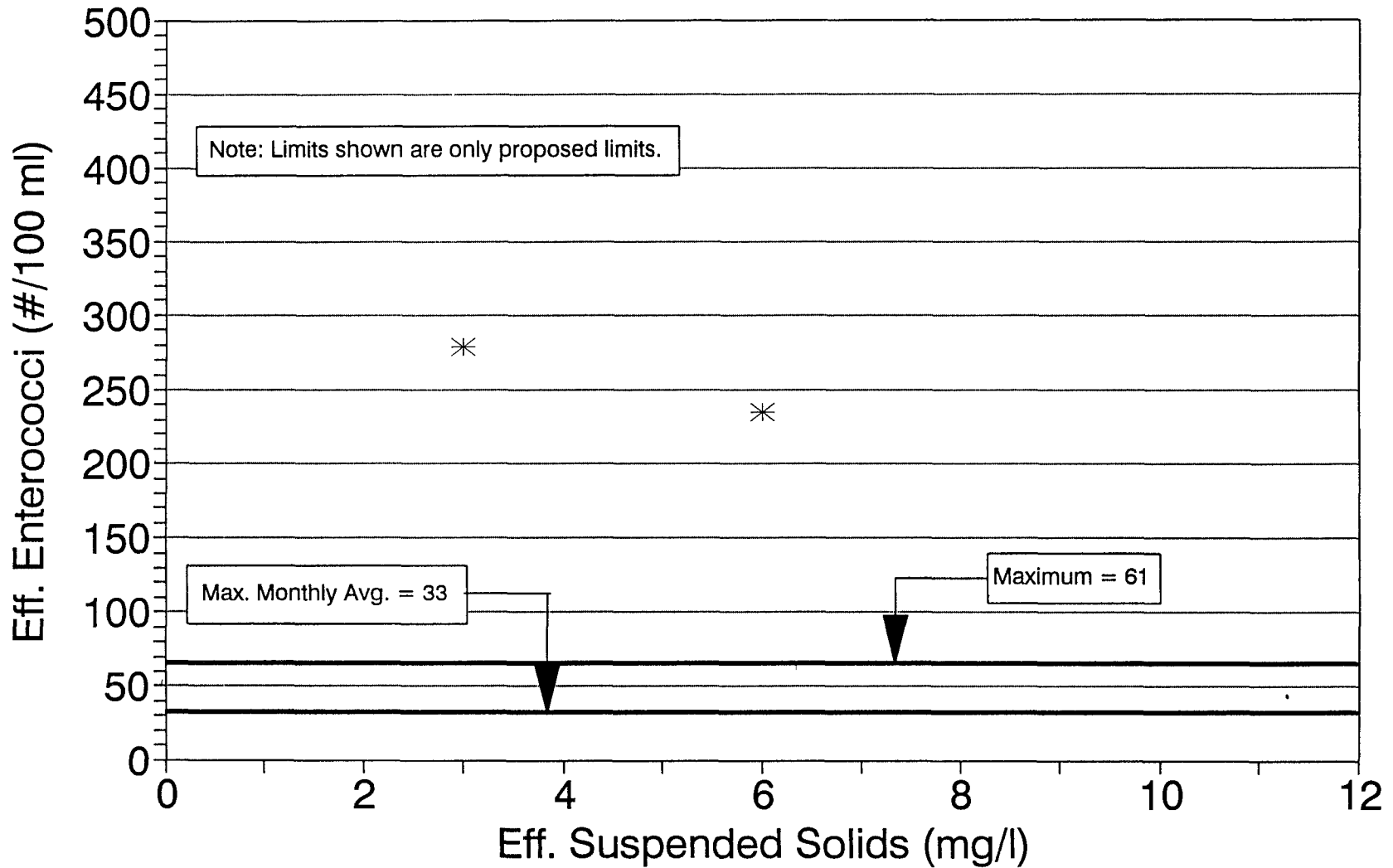
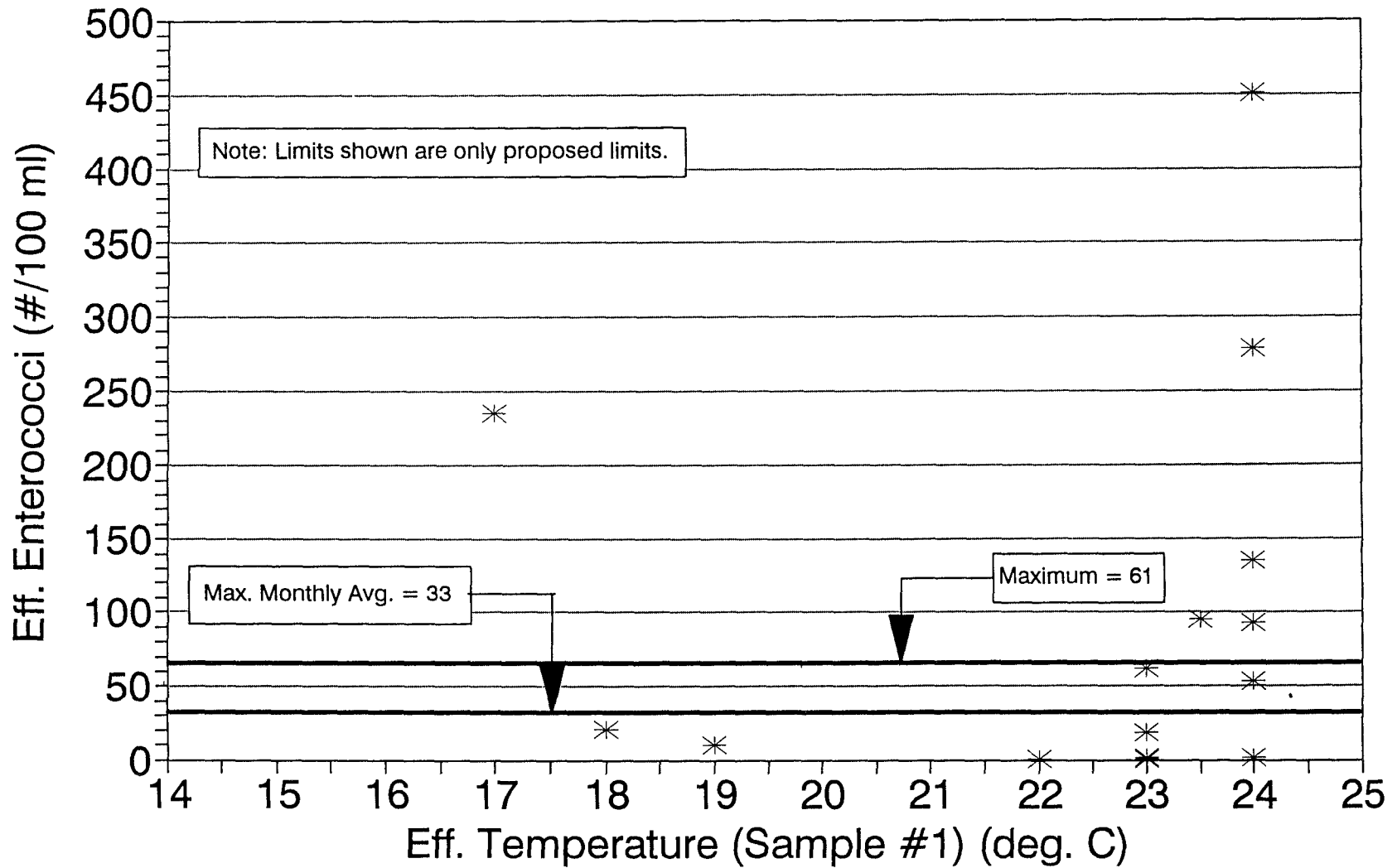

Figure 4-12. Verona WWTP Eff. Enterococci Vs. Eff. Temperature



ENDNOTES

¹Mohan V. Thampi, P.E., "Basic Guidelines for Specifying the Design of Ultraviolet Disinfection Systems," Pollution Engineering 22 (May 1990):65.

²Ibid.

³Richard H. Shertzer, "Wastewater Disinfection - Time for a Change?," Journal of Water Pollution Control Federation 58 (March 1986): 178.

⁴Ibid., p. 176.

⁵Ibid., pp. 176-178.

⁶S. C. White, E. Jernigan, and A. Venosa, "A Study of Operational Ultraviolet Disinfection Equipment at Secondary Treatment Plants," Journal of Water Pollution Control Federation, 58 (March 1986): 181.

⁷Mohan V. Thampi, P.E., "Basic Guidelines for Specifying the Design of Ultraviolet Disinfection Systems," Pollution Engineering 22 (May 1990): 65.

⁸U.S. Environmental Protection Agency, Office of Research and Development, Water Engineering Research Laboratory, Design Manual - Municipal Wastewater Disinfection, EPA/625/1-86/021 (October 1986), pp. 175-177.

⁹Ibid., p. 176.

¹⁰Ibid.

¹¹Ibid., pp. 176-177.

¹²Ibid., p. 177.

¹³S. White, E. Jernigan, and A. Venosa, "A Study of Operational Ultraviolet Disinfection Equipment at Secondary Treatment Plants," Journal of Water Pollution Control Federation 58 (March 1986): 181.

¹⁴Ibid.

¹⁵Mohan V. Thampi, P.E., "Basic Guidelines for Specifying the Design of Ultraviolet Disinfection Systems," Pollution Engineering 22 (May 1990): 65-66.

¹⁶Ibid., p. 66.

¹⁷Ibid.

¹⁸Ibid.

¹⁹Ibid.

²⁰System UV 2000 Brochure, by Trojan Technologies, Inc. (London, Ontario: Trojan Technologies, Inc., undated).

²¹Ibid.

²²System UV 2000 Brochure, by Trojan Technologies, Inc. (London, Ontario: Trojan Technologies, Inc., undated); Water and Sewage Works, August 1960, p. 60; C. B. Huff, H. F. Smith, W. O. Boring, N. A. Clarke, "Study Ultraviolet Disinfection of Water and Factors in Treatment Efficiency," Public Health Reports 80, 695 (1965); R. W. Kip, D. E. Konasewich, "Ultraviolet sterilization of Water - Its Potential and Limitation," Journal of Water Pollution Control Federation (June 1972): 14-18.

²³S. C. White, E. Jernigan, and A. Venosa, " Study of operational Ultraviolet Disinfection Equipment at Secondary Treatment Plants," Journal of Water Pollution Control Federation 58 (March 1986): 181-182.

²⁴Mohan V. Thampi, P.E., "Basic Guidelines for Specifying the Design of Ultraviolet Disinfection Systems," Pollution Engineering 22 (May 1990): 67.

²⁵Ibid.

²⁶Ibid.

²⁷Ibid., pp. 67-68.

²⁸Ibid., p. 67.

²⁹Ibid.

³⁰C. White, E. Jernigan, and A. Venosa, "A Study of Operational Ultraviolet Disinfection Equipment at Secondary Treatment Plants," Journal of Water Pollution Control Federation 58 (March 1986): 182.

³¹Ibid.

³²Ibid.

³³Ibid.

³⁴U.S. Environmental Protection Agency, Office of Research and Development, Water Engineering Research Laboratory, Design Manual - Municipal Wastewater Disinfection, EPA/625/1-86/021 (October 1986), pp. 228-233.

³⁵S. C. White, E. Jernigan, and A. Venosa, "A Study of Operational Ultraviolet Disinfection Equipment at Secondary Treatment Plants" Journal of Water Pollution Control Federation 58 (March 1986): 187.

³⁶Ibid.

³⁷Ibid.

³⁸Ibid.

³⁹Bruce E. Fletcher, Report Upon the Feasibility of Ultraviolet Light System and Chlorination and Dechlorination System for Disinfection at the New Providence Sewage Treatment Plant (Millburn, NJ: Elson T. Killam Associates, [May 1987]), pp. 10-11.

⁴⁰S.C. White, E. Jernigan and A. Venosa, "A Study of Operational Ultraviolet Disinfection Equipment at Secondary Treatment Plants" Journal of Water Pollution Control Federation 58 (March 1986): 187.

⁴¹Ibid., pp. 186-187.

⁴²Ibid., p. 186.

⁴³David Kirkwood, "Disinfecting with Ultraviolet Radiation," Civil Engineering 54 (Dec. 1984): 62-64.

⁴⁴Bruce E. Fletcher, Report Upon the Feasibility of Ultraviolet Light System and Chlorination and Dechlorination System for Disinfection at the New Providence Sewage Treatment Plant (Millburn, NJ: Elson T. Killam Associates, [May 1987]), p. 1.

⁴⁵Report Upon Basis of Design - Sewage Treatment Plant Modifications - Borough of New Providence (Millburn, NJ: Elson T. Killam Associates, [Jan. 1988]), pp. 1-3.

⁴⁶Ibid., p. 2.

⁴⁷Bruce E. Fletcher, Report Upon the Feasibility of Ultraviolet Light System and Chlorination and Dechlorination System for Disinfection at the New Providence Sewage Treatment Plant (Millburn, NJ: Elson T. Killam Associates, [May 1987]), pp. 1-3.

⁴⁸Ibid., pp. 5-7.

⁴⁹Ibid.

⁵⁰B. L. Severin and M. T. Suidan, "Ultraviolet Disinfection for Municipal Wstewater," Chemical Engineering Progress 81 (April 1985): 43.

⁵¹Report Upon Basis of Design - Sewage Treatment Plant Modifications - Borough of New Providence (Millburn, NJ: Elson T. Killam Associates, [Jan. 1988]), p. 4.

⁵²Fischer & Porter Company Ultraviolet Disinfection System Model No. 70UV2000 - Operations & Maintenance Manual for New Providence, NJ Wastewater Treatment Plant (Warminster, PA: Fischer & Porter Co., [March 1990]).

⁵³Clifford S. Wilkinson, Borough of New Providence Sewage Treatment Plant Modifications - Contract Specifications (Millburn, NJ: Elson T. Killam Associates, [May 1988]), pp. D8-1 - D8-2.

⁵⁴Fischer & Porter Company Ultraviolet Disinfection System Model No. 70UV2000 - Operations & Maintenance Manual for New Providence, NJ Wastewater Treatment Plant (Warminster, PA: Fischer & Porter Co., [March 1990]).

⁵⁵Ibid.

⁵⁶Ibid.

⁵⁷Ibid.

⁵⁸Ibid.

⁵⁹Ibid.

⁶⁰Ibid.

⁶¹S.C. White, E. Jernigan, and A. Venos, "A Study of Operational Ultraviolet Disinfection Equipment at Secondary Treatment Plants," Journal of Water Pollution Control Federation 58 (March 1986): 188.

⁶²Ibid., p. 182.

⁶³B. L. Severin and M. T. Suidan, "Ultraviolet Disinfection for Municipal Wastewater," Chemical Engineering Progress 81 (April 1985): 42.

⁶⁴Ibid., pp. 42-43.

⁶⁵Robert G. Qualls et al., "Factors Controlling Sensitivity in Ultraviolet Disinfection of Secondary Effluents" Journal of Water Pollution Control Federation 57 (Oct. 1985): 1008-1009.

⁶⁶Clayton H. Billings, "Photoreactivation and UV Disinfection," Public Works 118 (Nov. 1987): 98.

⁶⁷Robert G. Qualls et al., "Factors Controlling Sensitivity in Ultraviolet Disinfection of Secondary Effluents," Journal of Water Pollution Control Federation 57 (Oct. 1985): 1009.

⁶⁸Letters from Sidney Ellner, Ultraviolet Purification Systems, Inc., Bedford Hills, NY, 14 Dec. 1987 and 2 Nov. 1987.

⁶⁹B. L. Severin and M. T. Suidan, "Ultraviolet Disinfection for Municipal Wastewater," Chemical Engineering Progress 81 (April 1985): 42.

⁷⁰Mohan V. Thampi, "Basic Guidelines for Specifying the Design of Ultraviolet Disinfection Systems," Pollution Engineering 22 (May 1990): 66.

⁷¹U.S. Environmental Protection Agency, Office of Research and Development, Water Engineering Research Laboratory, Design Manual - Municipal Wastewater Disinfection, EPA/625/1-86/021 (October 1986), p. 225.

⁷²Mohan V. Thampi, "Basic Guidelines for Specifying the Design of Ultraviolet Disinfection Systems" Pollution Engineering 22 (May 1990): 65.

⁷³Clayton H. Billings, "Photoreactivation and UV Disinfection," Public Works 118 (Nov. 1987): 98.

⁷⁴Killam Associates, Brochure entitled "Township of Verona - Wastewater Treatment Plant," (Millburn, NJ: Killam Associates, June 1991).

⁷⁵Ibid.

⁷⁶Ibid.

⁷⁷Kenneth L. Zippler, Township of Verona, Essex County, New Jersey, Wastewater Treatment Plant Additions, Technical Design Report (Millburn, NJ: Elson T. Killam Associates,[April 1, 1988]), p.2.

⁷⁸Kenneth L. Zippler, Township of Verona Wastewater Treatment Plant Additions - Contract Drawings (Millburn, NJ: Elson T. Killam Associates,[June, 1988]), pp. D14-5 - D14-6.

⁷⁹Trojan UV Disinfection Equipment O & M Manual for the Verona, NJ WWTP (London, Ontario: Trojan Technologies, Inc., [March, 1990]).

⁸⁰Ibid.

⁸¹Ibid.

⁸²Ibid.

⁸³Ibid.

⁸⁴Ibid.

⁸⁵Ibid.

⁸⁶Ibid.

⁸⁷Ibid.

⁸⁸S. C. White, E. Jernigan and A. Venosa, "A Study of Operational Ultraviolet Disinfection Equipment at Secondary Treatment Plants," Journal of Water Pollution Control Federation 58 (March 1986): 188.

⁸⁹Robert G. Qualls et al., "Factors Controlling Sensitivity in Ultraviolet Disinfection of Secondary Effluents," Journal of Water Pollution Control Federation 57 (Oct. 1985): 1008.

⁹⁰Ibid., p. 1009.

⁹¹B. L. Severin and M. T. Suidan, "Ultraviolet Disinfection for Municipal Wastewater," Chemical Engineering Progress 81 (April 1985): 37-38.

⁹²U.S. Environmental Protection Agency, Office of Research and Development, Water Engineering Research Laboratory, Design Manual - Municipal Wastewater Disinfection, EPA/625/1-86/021 (Oct. 1986), p. 225.

⁹³Mohan V. Thampi, P.E., "Basic Guidelines for Specifying the Design of Ultraviolet Disinfection Systems," Pollution Engineering 22 (May 1990): 65.

⁹⁴U.S. Environmental Protection Agency, Office of Research and Development, Water Engineering Research Laboratory, Design Manual - Municipal Wastewater Disinfection, EPA/625/1-86/021 (Oct. 1986), pp. 207-208.

⁹⁵B. L. Severin and M. T. Suidan, "Ultraviolet Disinfection for Municipal Wastewater," Chemical Engineering Progress 81 (April 1985): 37-38.

⁹⁶Clayton H. Billings, "Photoreactivation and UV Disinfection," Public Works 118 (Nov. 1987): 98.

⁹⁷S. C. White, E. Jernigan and A. Venosa, "A Study of Operational Ultraviolet Disinfection Equipment at Secondary Treatment Plants," Journal of Water Pollution Control Federation 58 (March 1986): 181.

⁹⁸B. L. Severin and M. T. Suidan, "Ultraviolet Disinfection for Municipal Wastewater," Chemical Engineering Progress 81 (April 1985): 43.

⁹⁹Ibid.

¹⁰⁰Bruce E. Fletcher, Report Upon the Feasibility of Ultraviolet Light System and Chlorination and Dechlorination System for Disinfection at the New Providence Sewage Treatment Plant (Millburn, NJ: Elson T. Killam Associates, [May 1987]), p. 9.

¹⁰¹B. L. Severin and M. T. Suidan, "Ultraviolet Disinfection for Municipal Wastewater," Chemical Engineering Progress 81 (April 1985): 43.

¹⁰²Ibid.

BIBLIOGRAPHY

- Alfano, Orlando M.; Vicente, Manuel; Esplugas, Santiago; and Cassano, Alberto. "Radiation Field inside a Tubular Multilamp Reactor for Water and Wastewater Treatment." Industrial & Engineering Chemistry Research 29 (July 1990): 1270-1278.
- Billings, Clayton H. "Photoreactivation and UV Disinfection." Public Works 118 (November 1987): 98.
- Ellner, Sidney. Ultraviolet Purification Systems, Inc., Bedford Hills, New York, Letters, 2 November 1987 and 14 December 1987.
- Fahey, Richard J. "The UV Effect on Wastewater." Water Engineering & Management 137 (December 1990): 15-18.
- Fischer & Porter Company Ultraviolet Disinfection System Model No. 70UV2000 - Operation & Maintenance Manual for New Providence, NJ Wastewater Treatment Plant. Warminster, Pennsylvania: Fischer & Porter Co., [March 1990].
- Fletcher, Bruce E. Report Upon the Feasibility of Ultraviolet Light System and Chlorination and Dechlorination System for Disinfection at the New Providence Sewage Treatment Plant. Millburn, New Jersey: Elson T. Killam Associates, [May 1987].
- Havelaar, A. H., and Nieuwstad, Th. J. "Bacteriophages and Fecal Bacteria as Indicators of Chlorination Efficiency of Biological Treated Wastewater." Journal of Water Pollution Control Federation 57 (November 1985): 1084-1088.
- Kirkwood, David. "Disinfecting with Ultraviolet Radiation." Civil Engineering 54 (December 1984): 62-64.
- Mone, John G. "Ultraviolet Water Purification." Pollution Engineering 5 (December 1973).
- Nieuwstad, Th. J.; Hvelar, A. H.; and Van Olphen, M. "Hydraulic and Microbiological Characterization of Reactors for Ultraviolet Disinfection of Secondary Wastewater Effluent." Water Research 25 (July 1991): 775-783.
- Qualls, R. G.; Dorfman, M. H.; and Johnson, J. D. "Evaluation of the Efficiency of Ultraviolet Disinfection Systems." Water Research 23 (March 1989): 317-325.
- Qualls, R. G., and Johnson, J. D. "Modeling and Efficiency of Ultraviolet Disinfection Systems." Water Research 19 (August 1985): 1039-1046.
- Qualls, R. G.; Ossoff, S. F.; Chang, J. C. H.; Dorfman, M. H.; Dumais, C. M.; Lobe, D. C.; and Johnson, J. D. "Factors Controlling Sensitivity in Ultraviolet Disinfection of Secondary Effluents." Journal of Water Pollution Control Federation 57 (October 1985): 1006-1011.

- Report Upon Basis of Design - Sewage Treatment Plant Modifications - Borough of New Providence. Millburn, New Jersey: Elson T. Killam Associates, [January 1988].
- Severin, B. F., and Suidan, M. T. "Ultraviolet Disinfection for Municipal Wastewater." Chemical Engineering Progress 81 (April 1985): 37-44.
- Shertzer, R. H. "Wastewater Disinfection - Time for a Change?" Journal of Water Pollution Control Federation 58 (March 1986): 174-179.
- Thampi, M. V. "Basic Guidelines for Specifying the Design of Ultraviolet Disinfection Systems." Pollution Engineering 22 (May 1990): 65-69.
- "Township of Verona Wastewater Treatment Plant," Brochure. Millburn, New Jersey: Elson T. Killam Associates, June 1991.
- Trojan UV Disinfection Equipment O & M Manual for the Verona, NJ WWTP. London, Ontario: Trojan Technologies, Inc., [March 1990].
- U.S. Environmental Protection Agency. Office of Research and Development. Water Engineering Research Laboratory. Design Manual - Municipal Wastewater Disinfection, EPA/625/1-86/021. Cincinnati, Ohio: EPA, 1986.
- Vicente, M.; Alfano, O. M.; Esplugas, S.; and Cassano, A. E. "Design and Experimental Verification of a Tubular Multilamp Reactor for Water and Wastewater Treatment." Industrial & Engineering Chemistry Wastewater Treatment 29 (July 1990): 1278-1283.
- White, S. C.; Jernigan, E. B.; and Venosa, A. D. "A Study of Operational Ultraviolet Disinfection Equipment at Secondary Treatment Plants." Journal of Water Pollution Control Federation 58 (March 1986): 181-192.
- Wilkinson, Clifford S. Borough of New Providence Sewage Treatment Plant Modifications - Contract Specifications. Millburn, New Jersey: Elson T. Killam Associates, [May 1988].
- Zippler, Kenneth L. Township of Verona, Essex County, New Jersey, Wastewater Treatment Plant Additions, Technical Design Report. Millburn, New Jersey: Elson T. Killam Associates, [1 April 1988].
- Zippler, Kenneth L. Township of Verona Wastewater Treatment Plant Additions - Contract Specifications. Millburn, New Jersey: Elson T. Killam Associates, [June 1988].
- Zukovs, G.; Kollar, J.; Monteith, H. D.; Ho, K. W. A.; and Ross, S. A. "Disinfection of Low Quality Wastewaters by Ultraviolet Light Irradiation." Journal of Water Pollution Control Federation 58 (March 1986): 199-206.