



## *The validity of the TMMS-24 emotional intelligence scale in a context of music-oriented secondary school students in Italy*

Anna Patti-Signorelli<sup>a</sup> and José Javier Romero-Díaz de la Guardia<sup>b</sup>

<sup>a</sup>*State Omnicomprehensive Musical Institute, Milan, Italy*

<sup>b</sup>*Department of Research Methods and Diagnosis in Education, University of Granada, Spain*

The present study aimed to determine the emotional characteristics of the Trait-Meta-Mood-Scale (TMMS-24) in music-oriented secondary school students in Italy. A 24-item self-assessment protocol was applied to measure the level of perceived emotional intelligence according to 3 dimensions: attention, clarity and repair. This tool represents one of the most widely used self-assessment measures of perceived emotional intelligence. The objective of the study was to conduct construct validation to examine reliability of the Italian version of the TMMS-24 in order to identify its feasibility for the assessment of emotional intelligence. Exploratory and confirmatory factorial analyses were conducted on a sample of music-oriented secondary school students in Italy (n=402). Exploratory factor analysis outcomes revealed that the three dimensions of the original scale (attention, clarity and emotional repair) are supported in the examined context, showing adequate internal consistency and describing 52.6% of overall variance. Outcomes were confirmed via confirmatory analysis, obtaining good fit indices (CFI=0.986; TLI=0.985; RMSEA=0.038). The TMMS-24 scale is a valid and reliable instrument for measuring the emotional intelligence of secondary school students in Italy.

**Keywords:** TMMS-24, emotional intelligence, secondary school education, exploratory factor analysis, confirmatory factor analysis.

First submission 14<sup>th</sup> March 2023; Accepted for publication 2<sup>nd</sup> October 2023.

### **Introduction**

The concept of emotional intelligence (EI) first appeared in 1990 in a book by Salovey and Mayer (1990), in which its structure and its impact on behaviour and cognition were outlined. These authors defined EI as the

---

<sup>1</sup> Corresponding author. Email address: [annapattisignorelli@gmail.com](mailto:annapattisignorelli@gmail.com)

capacity to recognise, understand and regulate emotions, enabling individuals to enhance their thinking processes and foster personal development. Nonetheless, it was Daniel Goleman (1995) who popularised the term, defining it as the ability to recognise one's own feelings and those of others, motivate oneself and positively manage one's emotions, both internally and with regards to social relationships.

Emotions have a decisive influence on the learning process because a student who discovers a new world enthusiastically is stimulated through their curiosity and learns more effectively and easily than one who is obliged to learn or does so without interest (Pekrun, 1992). Music, being a universal language, is a useful tool because it allows individuals, not only, to recognize their emotions but, also, to express and share them.

The Trait Meta-Mood Scale (TMMS), (Salovey et al., 1995) is one of the most widely used instruments for measuring emotional intelligence in the adult population. Such studies in the context of education have grown in interest in recent years. However, no data is available regarding its application within the adolescent population or in relation to music-oriented studies in Italian schools. This paper sets to establish the validity of the TMMS-24 emotional intelligence scale in a context of music-oriented secondary school students in Italy.

### *Emotional intelligence*

The concept of emotional intelligence was introduced by Salovey and Mayer (1990), who illustrated the structure of emotional intelligence and its influence on behaviour and the mind in their article 'Emotional intelligence' in the journal *Imagination, Cognition and Personality*. These authors defined emotional intelligence as the ability to process and monitor information based on one's own emotions and those of others, differentiate different emotions and use resulting information to guide one's thinking and actions in order to facilitate cognitive activities and adaptive behaviour. After conducting several research studies, Mayer and Salovey (1997) modified their concept of emotional intelligence to include the ability to accurately perceive emotions, generate and understand emotions and, consequently, reactively regulate them in order to promote personal emotional and intellectual growth.

### *Musical intelligence*

Based on studies conducted with children endowed with different intellectual capacities, Gardner (1983) established that there are different forms of intelligence. According to Gardner's Theory of Multiple Intelligences, all individuals are intelligent in at least seven different ways. This means that some individuals possess very high levels in all or almost all intelligences, while others develop particular intelligences in a more enhanced way. However, it is important to understand that all individuals can develop the different intelligences to satisfactory levels. One of these intelligences is musical ability, and the author argues that music is one of the first talents to emerge in individuals. This involves the ability to compose, recognise and reproduce musical patterns, tones and rhythms (Gardner, 1993).

There is a profound relationship between emotions and music as music gives pleasure, arouses strong passions, stimulates memories (Davies, 1978), facilitates and strengthens social ties, and gives rise to a form

of communication that goes beyond words, stimulating inner awareness, enhancing well-being and improving mood. It has a strong influence on the body and a strong interaction with personal emotions (Vignati, 2005). This, in turn, regulates another aspect of people's lives as it governs all of the human relationships that allow us to open up to the world and relate to others.

Music allows us not only to feed our emotional intelligence, but, also, to recognise our emotions, express them and share them, being one of the most emotional forms of communication that exists (Bernardi, 2016). It has the power to speak to us because it is a language that can communicate without words, but it has the great ability to evoke and strengthen emotions (Cowen et al., 2020), induce feelings, regulate emotions, overcome shyness, and develop self-control and concentration skills. Moreover it has positive long-term effects. Children and young people who study it for years, even if not professionally, develop more enhanced logical and linguistic skills, have less difficulty socialising, and perform better at school because learning music improves cognitive functioning (Hille et al., 2011).

#### *Measuring emotional intelligence: The Trait Meta-Mood Scale (TMMS)*

Among the various existing instruments to measure EI, the Trait Meta-Mode Scale -TMMS- stands out as one of the most widely used worldwide (Fernández-Berrocal et al., 2012; Rincón & Rodríguez, 2018). This self-report questionnaire was designed to measure levels of perceived emotional intelligence as a function of three dimensions. From these, an overall index is produced that assesses the knowledge possessed by individuals of their own emotional state, providing a personal estimate of reflective aspects pertaining to their emotional experience (Extremera-Pacheco & Fernández-Berrocal, 2005). This scale was designed to measure relatively stable individual differences in responding to mood. The extended version of this scale of meta-awareness traits assesses 48 items pertaining to the way in which individuals perceive emotions and their approach towards understanding and regulating them (Salovey et al., 1995).

The TMMS-48 describes three dimensions of EI. The first, attention to emotions, consists of 21 items, with 15 pertaining to emotional clarity and 12 to emotional repair (Salovey et al., 1995; Mayer & Salovey 1997). All items are assessed on a 5-point Likert scale. However, the reduced version of the TMMS, consisting of 30 items, is recommended by the authors, as it retains all three dimensions but eliminates those with less internal consistency (Salovey et al., 1995).

Fernández-Berrocal et al., (1998) adapted the TMMS-48 for use with Spanish populations and found similar characteristics to those found in the original scale by Salovey and Mayer (1990). Subsequently they shortened to 24 items (Trait Meta-Mood Scale-24 (TMMS-24), Fernández-Berrocal et al., 2004). This version retains the three original scale components but contains only half of the items, retaining those with high internal consistency, and grouped into three factors: Attention to emotions, Emotional clarity and Emotional repair. In 2005, the TMMS-24 was validated with Portuguese population by Queirós et al., (2005), indicating that the three-factor structure was found to be stable and reliable. In 2010, Salguero et al., (2010) in a study with Spanish schoolchildren, confirmed the original scale structure but eliminated one item from the repair dimension, leaving 23 items. In 2014, Pedrosa et al., (2014) reported similar outcomes and supported the 24-

item structure. The TMMS-24 was also adapted for use in Chile (Gómez-Núñez et al., 2018) with a sample of adolescents. In this case, the three-factor structure with 24 items presented acceptable indices for adaptation within this population. The present study examines the validity of this tool for use with students in music-oriented secondary schools in Italy.

## Materials and methods

### *Participants*

A total of 402 students participated in the study, of which 203 were females and 199 were males aged between 12 and 14 years old. Participants were following the second and third academic year at one of two musically oriented secondary schools in the cities of Palermo and Menfi, Sicily, Italy (Table I).

Table I Sample distribution

City	Academic year	Gender	N
Palermo	2nd year	Male	53
		Female	44
	3rd year	Male	42
		Female	56
Menfi	2nd year	Male	56
		Female	57
	3rd year	Male	48
		Female	46
			402

### *Tools*

The Spanish version TMMS-24 (Fernández-Berrocal et al., 2004) developed from Salovey et al. (1995) was used in this study. The 24 items that make up the Spanish version are grouped in three factors, with eight items per dimension: Attention to feelings (items 1 to 8) (the degree to which individuals believe that they pay attention to their emotions and feelings); Emotional clarity (items 9 to 16) (the degree to which individuals believe that they perceive their emotions) and Emotional repair (items 17 to 24) (individuals' beliefs in their ability to interrupt and regulate negative emotional states and prolong positive ones) . A 5-point Likert scale was used, with 1 representing complete disagreement and 5 representing complete agreement. The internal consistency estimates for subscales of the Spanish version were all above .85, and the test-retest correlations after 4 wk. ranged from .60 to .83 (Fernandez-Berrocal et al., 2004). In the present study, Cronbach alpha coefficients are also above .85.

The English version of the TMMS-24 was translated into Italian using backward to forward procedure (see ANNEX I) and administered to 402 secondary school students attending second- and third-year classes of two secondary schools in Palermo and Menfi, Sicily. The questionnaire was administered at the first school

in paper format to 195 students. It was administered during school hours, in this way, keeping data collection time as short as possible while optimising data return. At the second school, an online version was used. A total of 207 students responded. Given all elements were compulsory, complete information was provided in all cases.

Alongside the questionnaire, which was administered anonymously, a series of items were added to collect descriptive information about the participants and identify students' level of experience with prior musical studies. Hence, the questionnaire was divided into two sections. The first section consisted of 17 questions which gathered general information about the personal characteristics of students (See Appendix I), whilst the second section included items belonging to the TMMS-24 scale. The questionnaire was administered between February and early June 2020/2021.

### *Data analysis*

Exploratory factor analysis was performed using the statistical package Jamovi 2.2.5 in order to assess the linguistic and conceptual adequacy of the translated Spanish version of TMMS-24 with Italian students. In order to estimate construct validity, principal components analysis with Oblimin rotation was performed, since it was hypothesised that the examined factors would be interrelated (Yong & Pearce, 2013). Mean, variance, skewness and kurtosis were calculated, following assessment of multivariate normality in order to verify whether data were normally distributed. Internal consistency of the overall scale and the obtained factors was determined via Cronbach  $\alpha$  and McDonald's  $\omega$  coefficients, setting the reliability index at 95%. As a complement, convergent validity was calculated using measures of average variance extracted (AVE) and composite reliability (CR).

Subsequently, confirmatory factor analysis was performed using structural equation modelling (SEM) to verify the reliability of the outcomes produced through preliminary exploratory factor analysis. RStudio 2021.09.0+351 software, version R 4.1.1. and the lavaan package, version 0.6-9 (Rosseel, 2012), were used to specify, identify, estimate and evaluate the developed model. Fit of the proposed models was estimated according to the chi-square statistic. In addition, given the sensitivity of this statistic to sample size (Schumacker & Lomax, 2010), other goodness of model fit measures, such as the comparative fit index (CFI) and the Tucker-Lewis index (TLI), were also used. In addition, absolute fit indices were estimated for all models based on root mean square error of approximation (RMSEA) and standardised root mean square residuals (SRMR) (Kline, 2016).

In order to obtain model parameter estimates and examine the goodness of model fit to the collected data, different estimators were compared. Specifically, the diagonally weighted least squares (DWLS) model, appropriate for categorical ordinal data (Xia & Yang, 2019; Savalei & Rhemtulla, 2013; Mîndrilă, 2010), and the maximum likelihood (ML) model were used. Once model fit was verified, parameter estimates were calculated and the significance of regression weights was examined.

## Results

### *Exploratory factor analysis*

Exploratory factor analysis (EFA) of the 24 items comprising the TMMS-24 showed that the data fit the model well and that a three-factor structure (attention, clarity and emotion repair) was appropriate. The model described 52.6 per cent of overall variance. Table II presents the outcomes of the preliminary analysis performed on the various items, including examination of skewness and kurtosis to determine data distribution. Skewness and kurtosis values for all variables fall within the range of -3.29 to +3.29. Thus, univariate normality is confirmed in accordance with the principles established by Mayers (2013). The assumption of homoscedasticity was verified through calculation of Bartlett's sphericity (4730; df 276,  $p < 0.001$ ) (Garson, 2012). Further, the Kaiser-Mayer Olkin (KMO) measure of sampling adequacy (MSA) indicated a high degree of adequacy, both at the variable level and in terms of the overall scale (KMO=0.902).

Table II. Descriptive statistics and calculation of MSA

	95% CI			Var	Skewness		Kurtosis		MSA
	Mean	Low	Upp		Skew	SE	Kurt	SE	
TMMS1	3.81	3.72	3.91	0.947	-0.6420	0.122	0.100	0.243	0.869
TMMS2	3.63	3.53	3.74	1.085	-0.4341	0.122	-0.440	0.243	0.911
TMMS3	3.44	3.32	3.55	1.419	-0.3811	0.122	-0.735	0.243	0.899
TMMS4	3.59	3.47	3.71	1.405	-0.4541	0.122	-0.745	0.243	0.886
TMMS5	3.37	3.25	3.49	1.500	-0.3553	0.122	-0.738	0.243	0.803
TMMS6	3.12	3.00	3.25	1.571	-0.0455	0.122	-0.995	0.243	0.846
TMMS7	3.39	3.28	3.50	1.320	-0.3434	0.122	-0.663	0.243	0.882
TMMS8	3.48	3.36	3.60	1.392	-0.3503	0.122	-0.831	0.243	0.893
TMMS9	3.34	3.22	3.46	1.537	-0.2907	0.122	-0.912	0.243	0.879
TMMS10	3.22	3.10	3.34	1.588	-0.2685	0.122	-0.939	0.243	0.904
TMMS11	3.42	3.31	3.54	1.407	-0.3426	0.122	-0.818	0.243	0.943
TMMS12	3.48	3.36	3.59	1.397	-0.5199	0.122	-0.514	0.243	0.923
TMMS13	3.51	3.41	3.61	1.069	-0.3468	0.122	-0.447	0.243	0.932
TMMS14	3.06	2.93	3.19	1.760	-0.1119	0.122	-1.112	0.243	0.889
TMMS15	3.21	3.09	3.33	1.505	-0.2596	0.122	-0.870	0.243	0.907
TMMS16	3.50	3.39	3.62	1.413	-0.4462	0.122	-0.623	0.243	0.907
TMMS17	3.41	3.28	3.54	1.878	-0.4656	0.122	-1.013	0.243	0.898
TMMS18	3.24	3.11	3.38	1.896	-0.2782	0.122	-1.153	0.243	0.910
TMMS19	3.04	2.90	3.18	2.061	-0.0504	0.122	-1.320	0.243	0.911
TMMS20	3.35	3.21	3.48	1.908	-0.3815	0.122	-1.063	0.243	0.927
TMMS21	3.42	3.30	3.55	1.631	-0.4695	0.122	-0.786	0.243	0.911
TMMS22	3.52	3.40	3.63	1.407	-0.4829	0.122	-0.530	0.243	0.913
TMMS23	4.27	4.17	4.37	1.032	-1.3432	0.122	1.043	0.243	0.796
TMMS24	3.37	3.24	3.49	1.719	-0.3923	0.122	-0.923	0.243	0.945

Note: CI (confidence interval); Low (lower limit); Upp (upper limit); Var (variance); SE (standard error); MSA (measurement of scale adequacy).

To obtain the factorial solution, the OBLIMIN factorial rotation method was used, given that factors were hypothesised a priori to be interrelated (Costello & Osborne, 2005). As can be seen in Table III, no factor loadings were below the threshold of 0.4, meaning that it was not necessary to discard any of the items included in the original scale (Stevens, 2002).

Table III. Factor loadings and unique variance

	<b>Component</b>			<b>Uniqueness</b>
	<b>1</b>	<b>2</b>	<b>3</b>	
TMMS1	0.646			0.569
TMMS2	0.425			0.620
TMMS3	0.698			0.498
TMMS4	0.661			0.583
TMMS5	0.624			0.641
TMMS6	0.737			0.420
TMMS7	0.810			0.329
TMMS8	0.659			0.485
TMMS9		0.747		0.423
TMMS10		0.749		0.366
TMMS11		0.742		0.431
TMMS12		0.587		0.602
TMMS13		0.714		0.500
TMMS14		0.702		0.498
TMMS15		0.675		0.494
TMMS16		0.823		0.354
TMMS17			0.833	0.350
TMMS18			0.837	0.299
TMMS19			0.804	0.317
TMMS20			0.829	0.314
TMMS21			0.627	0.534
TMMS22			0.638	0.455
TMMS23			0.430	0.828
TMMS24			0.682	0.469

Calculation of uniqueness values did not yield high values, except for variable TMMS23, with outcomes indicating that only 17.2% of the variance of this variable was explained by the factor in which it was included. However, considering that factor loadings pertaining to this factor are all greater than 0.4 and that it did not load onto any of the other factors, the decision was taken to retain the variable and observed outcomes produced in the subsequent confirmatory analysis.

Positive pairwise correlations were also found between all factors, with the strongest correlation being between factors 1 and 2, implying that these factors measure correlated constructs (Table IV).

Table IV. Correlation between factors

	1	2	3
1	—	0.513	0.398
2		—	0.301
3			—

Overall, as can be seen in Table V, the examined three-dimensional factorial structure explained 52.6% of overall accumulated variance, which is an acceptable outcome to confirm the factorial solution. Exploratory factor analysis thus confirmed the structure of the original version of the scale (Fernández-Berrocal et al., 2004).

Table V. Summary of the factor solution

Comp.	Eigenv	% Var	Cum %	Cronb $\alpha$	McDon $\omega$	AVE	CR
1	4.46	18.6	18.6	0.833	0.837	0.6	0.9
2	4.41	18.4	37.0	0.876	0.877	0.5	0.9
3	3.74	15.6	52.6	0.881	0.882	0.5	0.9

Note: Comp. (component); Eigenv (eigenvalues); % Var (% variance); Cum % (accumulative variance); Cronb  $\alpha$  (Cronbach alpha); McDon  $\omega$  (McDonald's  $\omega$ ); AVE (average variance extracted); CR (composite reliability).

#### *Internal consistency and reliability*

Cronbach  $\alpha$  and McDonald's  $\omega$  coefficients were adequate for all three subscales (attention:  $\alpha=0.833$  -  $\omega=0.837$ ; clarity:  $\alpha=0.876$  -  $\omega=0.877$ ; and repair:  $\alpha=0.881$  -  $\omega=0.882$ ) as they exceeded, in all cases, the threshold value of 0.7 defined by Pestana and Gageiro (2008). Furthermore, overall, high values were obtained for both statistics ( $\alpha=0.912$  -  $\omega=0.912$ ).

In light of these outcomes, it can be assumed that the scale has a high degree of internal consistency. In order to gain a more complete understanding of the reliability of these findings, measures of average variance extracted (AVE) and composite reliability (CR) were also calculated. This enables examination of the reliability of the factorial solution and whether obtained factors explain a sufficient amount of the variance observed in the studied variables. As can be seen in Table V, AVE was higher than 0.5, whilst CR exceeded the threshold of 0.7 for all factors. These outcomes indicate a reliable factorial solution (Fornell & Larcker, 1981) and that the TMMS-24 (Fernández-Berrocal et al., 2004), has suitable psychometric properties to be used as an instrument to measure emotional intelligence.

#### *Confirmatory factor analysis*

Confirmatory factor analysis (CFA) was performed to assess the validity of the previously identified model. This enables an examination of whether EFA outcomes produce an appropriate fit to the observed data and whether the hypothesised relationships between the observed and latent variables are real and consistent with



the results obtained. Further, CFA permits the detection of errors or distortions in the pattern identified by EFA, which can be useful in improving the quality and accuracy of obtained outcomes (Anderson & Gerbing, 1988). Despite impeding generalizability, it was decided to use the same sample for both analyses based on the favourable outcomes produced from the measurement of scale adequacy (MSA), which indicated strong measurement quality for individual items and the overall scale. EFA suggested that no item had to be discarded, while internal consistency and reliability analyses yielded acceptable values, both in average variance extracted (AVE) and composite reliability (CR).

Structural equation modelling (SEM) was proposed seeks to verify the reliability and accuracy of the proposed model as a representation of the actual data by comparing outcomes pertaining to two estimators (ML and DWLS). In both cases, statistically significant Chi-square values were obtained. However, given that the Chi-square statistics is highly sensitive to sample size, other fit indices were used to test developed models. As can be seen in Table VI, better fit indices were obtained using the DWLS method than the ML method. This confirms that the DWLS estimator is appropriate for categorical variables (Xia & Yang, 2019; Savalei & Rhemtulla, 2013; Mîndrilă, 2010). In this case, comparative fit (CFI) and Tucker-Lewis (TLI) indices were higher than 0.9 [CFI=0.986; TLI=0.985], whilst the root mean square error of approximation (RMSEA) was 0.038 and the normalised root mean square residual (SRMR) was 0.061. These parameters are within the established limits for acceptance of the proposed model and are indicative of good fit (Browne & Cudeck, 1992; Hu & Bentler, 1999; Kock, 2014).

Table VI. Fit indices

Method	CFI	TLI	RMSEA	SRMR
ML	0.836	0.819	0.086	0.068
DWLS	0.986	0.985	0.038	0.061

Following the selection of DWLS as an appropriate estimator, standardised regression weights were calculated, alongside their associated indicators for the proposed structural model, as measures of the relative contribution of variables to the factors identified in the previous analysis. As can be seen in Table VII, all relationships were found to be significant ( $p < 0.001$ ) and positive. This suggests that all variables make a meaningful independent contribution towards explaining the variance.

Of the eight items comprising emotional alertness, item TMMS7 ([I think about my feelings often]  $b=0.762$ ) explained most of variance in this factor, followed by item TMMS6 ([I constantly think about my state of mind]  $b=0.717$ ) and item TMMS8 ([I pay close attention to how I feel]  $b=0.706$ ). Of the eight items describing emotional clarity, items TMMS10 ([I can usually define my feelings]  $b=0.738$ ) and TMMS9 ([My feelings are clear to me]  $b=0.717$ ) exerted the greatest influence. However, the highest values emerged in emotional repair, with items TMMS19 ([When I feel sad, I think about all the pleasures in life]  $b=0.801$ ), followed by TMMS18 ([Even when I feel sad, I think about pleasant things]  $b=0.787$ ) and TMMS20 ([I try to have positive thoughts even when I feel bad]  $b=0.772$ ) being the most explanatory items. Items with the lowest

regression weights were items TMMS23 ([I have a lot of energy when I am happy]  $b=0.333$ ) and TMMS5 ([I allow my feelings to influence my thoughts]  $b=0.380$ ).

Table VII. Standardised regression weights

Factor	Item	Std. Est	Std. Err	Z	p
TMMS_ATT	TMMS7	0.762	0.035	21.691	<.001
	TMMS6	0.717	0.032	22.766	<.001
	TMMS8	0.706	0.033	21.438	<.001
	TMMS3	0.643	0.032	20.143	<.001
	TMMS2	0.641	0.034	19.132	<.001
	TMMS1	0.578	0.034	17.126	<.001
	TMMS4	0.521	0.03	17.581	<.001
	TMMS5	0.38	0.027	13.916	<.001
	TMMS_CLA	TMMS10	0.776	0.031	25.407
TMMS16		0.738	0.032	23.226	<.001
TMMS9		0.717	0.03	24.032	<.001
TMMS11		0.697	0.03	23.315	<.001
TMMS15		0.686	0.029	23.638	<.001
TMMS14		0.658	0.027	24.184	<.001
TMMS13		0.619	0.03	20.607	<.001
TMMS12		0.6	0.029	20.428	<.001
TMMS_REP		TMMS19	0.801	0.028	28.742
	TMMS18	0.787	0.029	27.129	<.001
	TMMS20	0.772	0.03	25.885	<.001
	TMMS22	0.741	0.033	22.678	<.001
	TMMS17	0.72	0.029	24.873	<.001
	TMMS24	0.695	0.029	23.791	<.001
	TMMS21	0.658	0.03	22.31	<.001
	TMMS23	0.333	0.027	12.341	<.001
TMMS_ATT	TMMS_CLA	0.532	0.018	29.361	<.001
TMMS_ATT	TMMS_REP	0.431	0.017	25.795	<.001
TMMS_CLA	TMMS_REP	0.627	0.016	38.354	<.001
Note: Std. Est. (standardised regression weights); Std. Err (standardised error)					

In addition, positive correlations were found between the three dimensions of the TMMS-24 scale, with higher scores in one dimension associated with higher scores in the other dimensions (Hair et al., 2014). In the present context, this suggests that the three emotional abilities are interrelated and that greater capacity in one area may lead to better competence in the other areas.

Figure 1 represents the structural model obtained after performing confirmatory factor analysis, presenting standardised regression weights, as well as the associations between endogenous variables. The diagonally weighted least squares (DWLS) method yielded better outcomes, as evidenced by CFI, TLI, RMSEA and SRMR values. Standardized regression weights for all items, except for two, were moderately high. Additionally, the three dimensions of the scale were found to be interrelated, with moderate values observed in all cases.

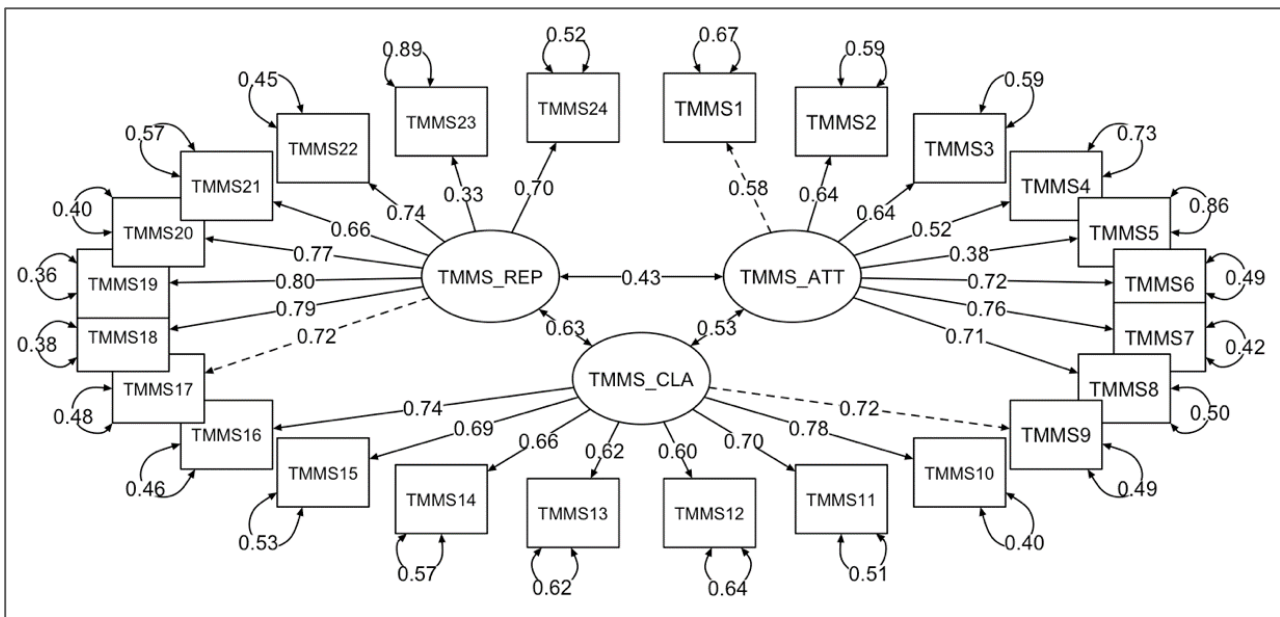

Figure 1. Structural model produced by CFA

## Discussion and conclusions

The aim of the present study was to examine the psychometric properties of the TMMS-24 scale in the context of music-oriented secondary schools in Italy. Present findings confirm that the psychometric properties of the instrument are adequate and consistent with those reported for the original scale (Salovey et al., 1995) and in its adaptation into Spanish (Fernández-Berrocal et al., 2004). EFA revealed adequate fit of the model to the data, highlighting a three-factor structure (attention, clarity and emotional repair) that describes 52.6% of overall variance. Examination of the scale's internal consistency and reliability, as measured through Cronbach  $\alpha$  and McDonald's  $\omega$  coefficients, yielded highly positive values (Pestana & Gageiro, 2008), as did complementary analysis via average variance extracted (AVE) and composite reliability (CR).

CFA enabled the proposed model to be validated and revealed that scale items correspond to the attention, clarity and repair dimensions proposed by the authors of the original scale (Salovey et al., 1995). The 8 items composing the first two dimensions group together coherently, but in the case of the third dimension, item 23 presents a lower factor loading than the other items within this dimension, and similarly item 5 with regards to the overall scale. Similar findings have been reported by other studies (Salguero et al., 2010), suggesting that item 23 should be removed from the scale, alongside item 5 (Martín-Albo et al., 2010).

Considering that the removal of these items did not result in a substantial improvement in model fit, it was decided to retain both variables. This is in line with the recommendation by Aradilla-Herrero et al., (2013), given that low variability within the scale does not invalidate its reliability. Thus, in accordance with recommendations made by Stevens (2002), it was not necessary to remove any of the items from the scale. In conclusion, the three-dimensionality of the scale and its reliability were confirmed. This supports its use within the examined population, suggesting that TMMS-24 scale provides a quality measure of emotional intelligence.

Main outcomes of the present study demonstrate the suitability of the scale, obtaining good fit and reliability indices through both exploratory and confirmatory factor analysis. Validation outcomes supported the retention of the original 24 scale items and its three-factor structure (attention, clarity and emotional repair). This is consistent with Salovey et al. (1995)'s original scale as well as the Spanish version (Fernández-Berrocal et al., 2004), and with findings reported by other studies conducted to validate this scale (Delhom et al., 2017; González et al., 2020).

The main limitation of the present study concerns the sample size which, although considered appropriate for a validation study, was not very large. Furthermore, as is often the case with studies making use of self-perceptions, data collection may be influenced by distractions or socially desirable responding. Another limitation of was the use of the same sample for both EFA and CFA. Although this approach yielded valuable insights, it inherently limits the generalisability of findings to other populations or contexts. Outcomes obtained from this specific sample may not be representative of other populations or settings, emphasising the need for caution when extending the findings beyond the present sample. Future research should aim to replicate the analysis with diverse samples to enhance the generalisability of the results.

## Disclosure

All authors declare that they have no conflicts of interest.

## References

- Anderson, J. C., & Gerbing, D. W. (1988). Structural equation modeling in practice: A review and recommended two-step approach. *Psychological Bulletin*, *103*(3), 411-423.  
<https://doi.org/10.1037/0033-2909.103.3.411>
- Aradilla-Herrero, A., Tomás-Sábado, J., & Gómez-Benito, J. (2013). Perceived emotional intelligence in nursing: psychometric properties of the Trait Meta-Mood Scale. *Journal of Clinical Nursing*, *23*(7-8). <https://doi.org/10.1111/jocn.12259>
- Bernardi, N. F. (2016). Music and Movement: From Theory to Practice. *Ricerche di Psicologia*.  
<https://doi.org/10.3280/RIP2016-002004>
- Browne, M. W., & Cudeck, R. (1992). Alternative Ways of Assessing Model Fit. *Sociological Methods & Research*, *21*(2), 230–258. <https://doi.org/10.1177/0049124192021002005>

- Costello, A. B., & Osborne, J. W. (2005). Best practices in exploratory factor analysis: Four recommendations for getting the most from your analysis. *Practical Assessment, Research & Evaluation, 10*(7). <https://doi.org/10.7275/jyj1-4868>
- Cowen, A. S., Fang, X., Sauter, D., & Keltner, D. (2020). What music makes us feel: At least 13 dimensions organize subjective experiences associated with music across different cultures. *Proceedings of the National Academy of Sciences of the United States of America, 117*(4), 1924-1934. <https://doi.org/10.1073/pnas.1910704117>
- Davies, J. B. (1978). *The Psychology of Music*. Hutchinson.
- Delhom, I., Gutiérrez, M., Lucas-Molina, B., & Meléndez, J. C. (2017). Emotional intelligence in older adults: psychometric properties of the TMMS-24 and relationship with psychological well-being and life satisfaction. *International Psychogeriatrics, 29*(8), 1327-1334. <https://doi.org/10.1017/S1041610217000722>
- Extremera-Pacheco, N., & Fernández-Berrocal, P. (2005). Inteligencia emocional percibida y diferencias individuales en el meta-conocimiento de los estados emocionales: una revisión de los estudios con el TMMS. *Ansiedad y Estrés, 11*(2-3), 101-122.
- Fernández-Berrocal, P., Alcaide, R., Domínguez, E., Fernández-McNally, C., Ramos, N. S., & Ravira, M. (1998). Adaptación al castellano de la escala rasgo de metaconocimiento sobre estados emocionales de Salovey et al.: datos preliminares. *Libro de Actas del V Congreso de Evaluación Psicológica, 1*, 83-84.
- Fernández-Berrocal, P., Berrios-Martos, P., Extremera-Pacheco, N., & Augusto, J. M. (2012). Inteligencia emocional: 22 años de avances empíricos. *Behavioral Psychology, 20*(1), 5-14.
- Fernández-Berrocal, P., Extremera-Pacheco, N., & Ramos, N. (2004). Validity and reliability of the Spanish modified version of the Trait Meta-Mood Scale. *Psychological Reports, 94*(3), 751-755.
- Fornell, C., & Larcker, D. F. (1981). Evaluating structural equation models with unobservable variables and measurement error. *Journal of Marketing Research, 18*(1), 39-50. <https://doi.org/10.2307/3151312>
- Gardner, H. (1983). *Frames of Mind: A Theory of Multiple Intelligences*. Basic Books. <https://doi.org/10.1177/001698628502900212>
- Gardner, H. (1993). *Multiple Intelligences: The Theory in Practice*. Basic Books.
- Garson, G. D. (2012). *Testing Statistical Assumptions*. Statistical Associates Publishing.
- Goleman, D. (1995). *Emotional Intelligence*. Bantam Books.
- Gómez-Núñez, M., Torregrosa, M., Inglés, C., Lagos San Martín, N., Sanmartín, R., Vicent, M., et al. (2018). Factor invariance of the trait meta-mood scale-24 in a sample of Chilean adolescents. *Journal of Personality Assessment 102*, 231-237. <https://doi:10.1080/00223891.2018.1505730>
- González, R., Custodio, J. B., & Abal, F. J. P. (2020). Propiedades psicométricas del Trait Meta- Mood Scale-24 en estudiantes universitarios argentinos. *Psicogente, 23*(44), 1-26. <https://doi.org/10.17081/psico.23.44.3469>

- Hair, J. F., Black, W. C., Babin, B. J., & Anderson, R. E. (2014). *Multivariate Data Analysis (7th ed.)*. Pearson.
- Jakubowski, K., & Ghosh, A. (2019). Music evoked autobiographical memories in everyday life. *Psychology of Music, 49*(3), <https://doi.org/10.1177/0305735619888803>
- Kline, R. B. (2016). *Principles and Practice of Structural Equation Modeling (4th ed.)*. The Guilford Press.
- Kock, N. (2014). Advanced mediating effects tests, multi-group analyses, and measurement model assessments in PLS-based SEM. *International Journal of E-Collaboration (IJEC), 10*(1), 1–13. <https://doi.org/10.4018/ijec.2014010101>
- Hille, K., Gust, K., Bitz, U., & Kammer, T. (2011). Associations between music education, intelligence, and spelling ability in elementary school. *Advances in Cognitive Psychology, 7*(2011), 1-6. <https://doi.org/10.2478/v10053-008-0082-4>
- Hu, L. T., & Bentler, P. M. (1999). Cutoff criteria for fit indexes in covariance structure analysis: Conventional criteria versus new alternatives. *Structural Equation Modeling: A Multidisciplinary Journal, 6*(1), 1–55. <https://doi.org/10.1080/10705519909540118>
- Martin-Albo, J., Nuñez, J. L., & Leon J. (2010). Analysis of the psychometric properties of the Spanish version of the Trait Meta-Mood Scale in a sports context. *Psychol Reports, 106*(2), 477-89. <https://doi.org/10.2466/pr0.106.2.477-489>
- Mayers, A. (2013). *Introduction to statistics and SPSS in psychology*. Pearson.
- Mayer, J. D., & Salovey, P. (1997). What is emotional intelligence? In P. Salovey and D. Sluyter (Ed.). *Emotional development and emotional intelligence: Implications for educators* (pp. 3-31). Basic Books.
- Míndrilã, D. (2010). Maximum likelihood (ML) and diagonally weighted least squares (DWLS) estimation procedures: A comparison of estimation bias with ordinal and multivariate non-normal data. *International Journal of Digital Society, 1*(1), 60-66. <https://doi.org/10.20533/ijds.2040.2570.2010.0010>
- Pedrosa, I., Suárez-Álvarez, J., Lozano, L., Muñiz, J., & García-Cueto, E. (2014). Assessing perceived emotional intelligence in adolescents. *Journal Psychoeducational Assessment, 32*, 737–746. <https://doi:10.1177%2F0734282914539238>
- Pekrun, R. (1992). The impact of emotions on learning and achievement: Towards a theory of cognitive/motivational mediators. *Applied Psychology: An International Review, 41*(4), 359-376. <https://doi.org/10.1111/j.1464-0597.1992.tb00712.x>
- Pestana, M., & Gageiro, J. (2008). *Análise de Dados para Ciências Sociais - A Complementaridade do SPSS*. 5ª ed. Silabo.
- Queirós, M., Fernández-Berrocal, P., Extremera, N., Carral, J., & Queirós, P. (2005). Validação e fiabilidade da versão portuguesa modificada da Trait Meta-Mood Scale. *Psicologia, Educação e Cultura, 9*, 199–216.

- Rosseel, Y. (2012). lavaan: An R Package for Structural Equation Modeling. *Journal of Statistical Software*, 48(2), 1-36. <https://doi.org/10.18637/jss.v048.i02>
- Rincón, R. A., & Rodríguez, Á. P. A. (2018). Validez y confiabilidad de la escala rasgo de metacognición emocional (TMMS-24) en profesores universitarios. *Revista Lebret*, 10, 61-72. <https://doi.org/10.15332/rl.v0i10.2197>
- Salguero, J. M., Fernández-Berrocal, P., Balluerka, N., & Aritzeta, A. (2010). Measuring perceived emotional intelligence in adolescent population: Psychometric properties of the Trait Meta Mood Scale. *Social Behavior and Personality: An International Journal*, 38(9), 1197-1210. <https://doi.org/10.2224/sbp.2010.38.9.1197>
- Salovey, P., & Mayer, J. D. (1990). Emotional intelligence. *Imagination, cognition and personality*, 9, 185-211. <https://dx.doi.org/10.2190/DUGG-P24E-52WK-6CDG>
- Salovey, P., Mayer, J. D., Goldman, S. L., Turvey, C., & Palfai, T. P. (1995). Emotional attention, clarity, and repair: exploring emotional intelligence using the trait meta-mood scale. In J. W. Pennebaker (ed.), *Emotion, disclosure, and health* (pp. 125-154). American Psychological Association <http://dx.doi.org/10.1037/10182-006>
- Savalei V., & Rhemtulla, M. (2013). The performance of robust test statistics with categorical data. *British Journal of Mathematical and Statistical Psychology*, 66(2), 201-223. <https://doi.org/10.1111/j.2044-8317.2012.02049.x>
- Schumacker, R. E., & Lomax, R. G. (2010). *A beginner's guide to structural equation modeling (3rd ed.)*. Routledge Academic.
- Stevens, J. P. (2002). *Applied multivariate statistics for the social sciences (4th ed.)*. Erlbaum.
- Vignati, R. (2005). A scuola di emozioni. Punt. edu Riforma. [www.indire.it](http://www.indire.it)
- Xia, Y., & Yang Y. (2019). RMSEA, CFI, and TLI in structural equation modeling with ordered categorical data: The story they tell depends on the estimation methods. *Behavior Research Methods*, 51(1), 409-428. <https://doi.org/10.3758/s13428-018-1055-2>
- Yong, A. G., & Pearce, S. (2013) A Beginner's Guide to Factor Analysis: Focusing on Exploratory Factor Analysis. *Tutorials in Quantitative Methods for Psychology*, 9(2), 79-94. <https://doi.org/10.20982/tqmp.09.2.p079>

## **Appendix I. Italian translation of TMMS-24**

- 1) Faccio molta attenzione ai sentimenti.
- 2) Di solito sono molto consapevole di come mi sento.
- 3) Di solito passo del tempo a pensare alle mie emozioni.
- 4) Penso che le mie emozioni e il mio stato d'animo meritino attenzione.
- 5) Permetto ai miei sentimenti di influenzare i miei pensieri.
- 6) Penso costantemente al mio stato d'animo.
- 7) Penso spesso ai miei sentimenti.
- 8) Faccio molta attenzione a come mi sento.
- 9) I miei sentimenti mi sono chiari.
- 10) Di solito riesco a definire i miei sentimenti.
- 11) So quasi sempre come mi sento.
- 12) Di solito so come mi sento nei confronti delle persone.
- 13) Sono spesso consapevole dei miei sentimenti in situazioni diverse.
- 14) Posso sempre dire come mi sento.
- 15) Riesco a volte a dire quali emozioni sto provando.
- 16) Riesco a capire i miei sentimenti.
- 17) Anche se a volte mi sento triste, tendo ad avere una visione ottimistica.
- 18) Anche quando mi sento triste, penso a cose piacevoli.
- 19) Quando sono triste, penso a tutti i piaceri della vita.
- 20) Cerco di avere pensieri positivi anche quando mi sento male.
- 21) Se penso troppo alle cose e finisco per complicarle, cerco di calmarmi.
- 22) Mi assicuro di avere un buono stato d'animo.
- 23) Ho molta energia quando sono felice.
- 24) Quando sono arrabbiato cerco di cambiare il mio stato d'animo.