

Measurement technique to determine modal parameters of friction induced resonance

Citation for published version (APA):

Nuij, P. W. J. M. (2002). Measurement technique to determine modal parameters of friction induced resonance. In P. Sas, & B. van Hal (Eds.), *Noise and vibration engineering : proceedings of ISMA 2002 : international conference on noise and vibration engineering, Leuven, September 16-18, 2002* (pp. 479-484).

Document status and date:

Published: 01/01/2002

Document Version:

Publisher's PDF, also known as Version of Record (includes final page, issue and volume numbers)

Please check the document version of this publication:

- A submitted manuscript is the version of the article upon submission and before peer-review. There can be important differences between the submitted version and the official published version of record. People interested in the research are advised to contact the author for the final version of the publication, or visit the DOI to the publisher's website.
- The final author version and the galley proof are versions of the publication after peer review.
- The final published version features the final layout of the paper including the volume, issue and page numbers.

[Link to publication](#)

General rights

Copyright and moral rights for the publications made accessible in the public portal are retained by the authors and/or other copyright owners and it is a condition of accessing publications that users recognise and abide by the legal requirements associated with these rights.

- Users may download and print one copy of any publication from the public portal for the purpose of private study or research.
- You may not further distribute the material or use it for any profit-making activity or commercial gain
- You may freely distribute the URL identifying the publication in the public portal.

If the publication is distributed under the terms of Article 25fa of the Dutch Copyright Act, indicated by the "Taverne" license above, please follow below link for the End User Agreement:

www.tue.nl/taverne

Take down policy

If you believe that this document breaches copyright please contact us at:

openaccess@tue.nl

providing details and we will investigate your claim.

Measurement technique to determine modal parameters of friction induced resonance.

Pieter Nuij

Control Systems Technology,
Department of Mechanical Engineering,
Eindhoven University of Technology,
PO Box 513, 5600 MB Eindhoven, The Netherlands.
E-mail: p.w.j.m.nuij@tue.nl

Abstract

A frequency domain based measurement method is presented to determine modal parameters of friction-induced resonance in a mechanical system. This resonance occurs in the stick-phase and is due to the tangential stiffness in the friction contact in combination with the inertia of the system. The resonance frequency and damping are functions of the RMS level of the motion of the system and of the type of the applied excitation signal. Several experiments are carried out using random excitation and sine on random signals.

1 Introduction

In many mechanical positioning systems control performance is adversely affected by friction [1], [2]. The dynamical behaviour of these systems depends upon the state of the system. In the pre-sliding regime, the friction contact reacts as a stiffness [3]. In the sliding regime tangential stiffness diminishes and the damping behaviour becomes dominant.

Since a stiffness in combination with a mass or an inertia constitutes a second order system, a mechanical system with friction in the pre-slide phase will exhibit a resonance. The frequency and damping of this resonance will depend upon the relative movement in the friction contact. In [4] a measurement technique is described to estimate the apparent stiffness and damping in this phase. The results show an excitation signal level dependent magnitude of the bristle stiffness σ_0 . The possible excitation level dependency of the damping magnitude being the sum of the bristle damping σ_1 and viscous damping σ_2 is not discussed. In this paper the results of [4] will be further extended.

2 Problem definition

2.1 Measurement of frequency response function in stick-phase

The aim of this research is to develop and test a measurement method that can be used to determine the Frequency Response Function (FRF) of a mechanical system in its stick-phase. From this FRF the frequency and damping of the resonance, caused by the friction induced stiffness and system inertia/mass, can be determined as a function of excitation signal characteristics.

2.2 Choice of excitation signal

Since friction behaviour depends heavily upon the state of the system, the spectral energy distribution of the excitation signal must be carefully chosen. A random noise excitation signal with known RMS value and bandwidth is often used for FRF measurements in non-linear systems, since the resulting FRF is the best linear approximation of the non linear system. [5]. However its gaussian amplitude distribution with a crestfactor of approximately 3.5 can make local linearization impossible and might force a system, subjected to friction, through the stick-phase into the slip-phase.

The amplitude distribution of sine on random is narrower but still has the benefit of linearization of non-linear behaviour. Figure 1 shows the amplitude distribution for a random signal and a sine on random signal, both with equal RMS value of 0.5V. The sine on random signal has a crestfactor of approximately $\sqrt{2}$, the crestfactor of the random signal is 3 or more.

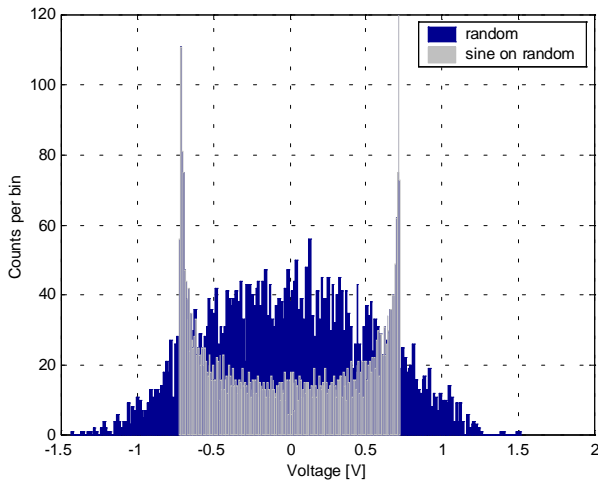

Figure 1: Amplitude distribution

Both types of excitation will be used in the measurements to determine the possible influence of 1) the difference in crestfactor and 2) the sine frequency on the estimates of the resonance frequency and damping.

3 Measurements

3.1 Measurement set-up

The mechanical system consists of a 20 W electric DC collector motor with encoder (Parvex RS110MR1000) and is powered by a voltage to current converter (Philips DCPA 50/2). The system response can be measured in terms of angular displacement, velocity or acceleration. The expected rotations in the stick-phase are in the order of magnitude of $1e-5$ rad. This will be difficult to measure with an angular position sensor. In acceleration terms however, $1e-5$ rad at 100 Hz corresponds to 4 rad/s^2 and can be measured reliably with an angular acceleration sensor system [6] (Kistler type 8832, TAP8696 sensor and 5130A coupler).

The measurement set-up, see figure 2, is placed onto a granite base to reduce the influence of external vibrations.

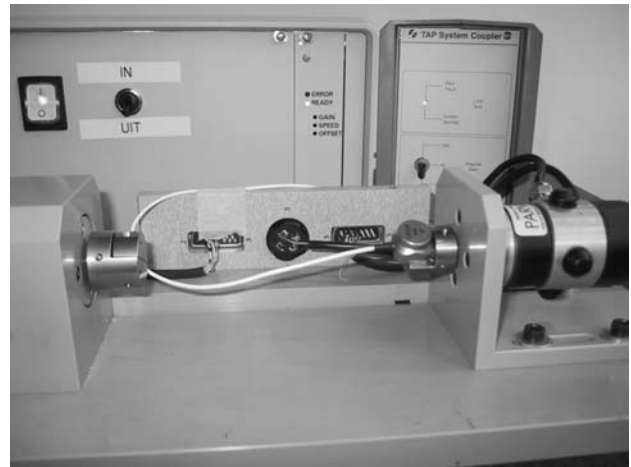

Figure 2: Measurement set-up

Due to the brushes, seals and bearings in the motor the system is subjected to friction. In the LuGre model [3] this friction influence is modelled with σ_0 , the bristle stiffness, σ_1 the bristle damping and σ_2 , the viscous damping. In order to determine the influence of these parameters on the system dynamics, FRF's are measured. V_{in} is the input signal into the linear voltage to current converter. Its output current I is converted by the motor into a torque T . The output signal is the angular acceleration of the motor shaft $\dot{\omega}_{out}$ and is measured with a Kistler angular acceleration sensor. Both signals are processed with a SigLab 20-42 dynamic signal analyzer [7], and MatLab 5.3. A schematic representation of the system is given in figure 3.

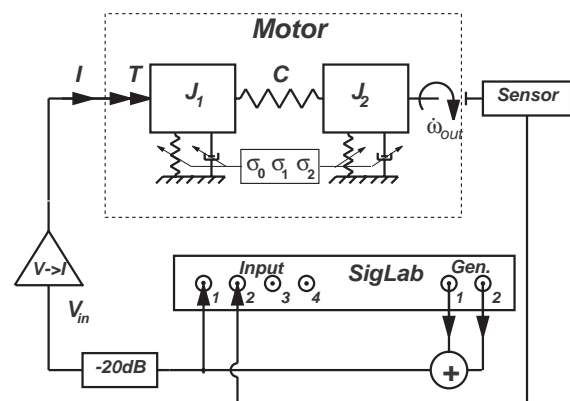

Figure 3: Schematic representation of system

3.2 Measurement procedure

In all measurements the H_1 frequency response function i.e. G_{AB}/G_{AA} was determined between \mathbf{V}_{in} and $\dot{\omega}_{out}$ in the frequency range 0 Hz to 2000 Hz with a frequency line spacing of 1.25 Hz, resulting in an effective frequency resolution of $1.5 \cdot 1.25$ Hz due to Hanning weighting of both channels. Every FRF was calculated using linear averaging of 20 data blocks of 800msec, acquired with free run averaging.

Table 1 gives an overview over the applied excitation signals \mathbf{V}_{in} . In all excitation signals, the random noise component is band-limited to 2000Hz. The sine frequencies are chosen to 1) coincide with an FFT line to avoid leakage, 2) not be harmonically related to 50Hz and 3) to enclose the friction-induced resonance because the relation between its modal parameters and the excitation frequency is unknown.

Series	Excitation signal	Sine component	Noise component
1	Sine on random	190Hz 0mV \rightarrow 32.5mV	0.5mV
2	Sine on random	810Hz 0mV \rightarrow 210mV	0.5mV
3	Random	none	1mV \rightarrow 80mV

Table 1: Excitation signal characteristics

A 20dB attenuator (see fig. 3) was placed to increase the dynamic range of the reference channel due to its electrical noise floor and the very low measurement signals.

4 Results

4.1 Slip phase dynamics

A visible movement of the motor shaft required a \mathbf{V}_{in} of approximately 1V. In this measurement the 20dB attenuator was omitted. As a reference for subsequent measurements the FRF $\dot{\omega}_{out}/\mathbf{V}_{in}$ of the system operating in the slip-phase was measured, see figure 4. The structural resonance at 1600Hz is due to the inertia's \mathbf{J}_1 and \mathbf{J}_2 and stiffness \mathbf{C} . The phase-plot indicates also high frequency poles caused by the inductance of the motor and the amplifier.

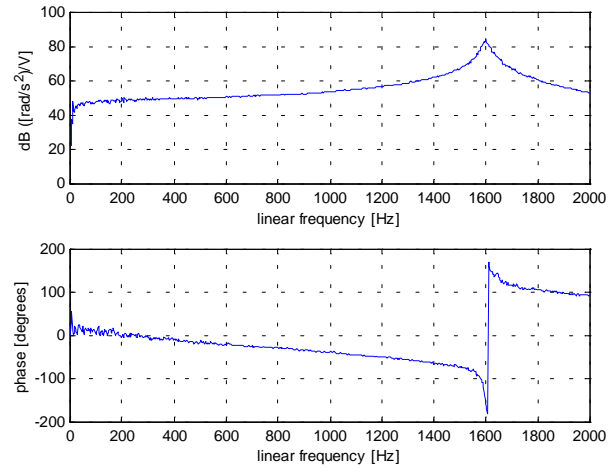

Figure 4: FRF of the system in the slip phase

4.2 Stick phase dynamics

To investigate the stick-phase dynamics over a wide excitation range, the excitation signal \mathbf{V}_{in} will be varied between 0.5mV and 80mV. The 20 dB attenuator is placed in the generator signal path.

4.2.1 Band limited random noise measurements

Figure 5 shows the FRF's obtained after excitation with 45mV and 1mV. The friction-induced resonance at about 500 Hz for 1mV and about 400 Hz for the 45mV excitation is clearly visible and its modal parameters depend heavily upon excitation level. The frequency and damping of the second resonance near 1700 Hz also have changed compared to figure 4 due to an increased stiffness σ_0 and decreased damping σ_1 .

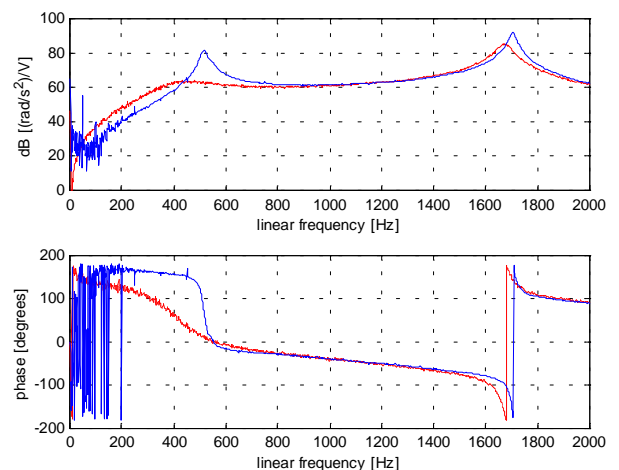

Figure 5: FRF of the system in the stick phase.

In figure 6 and 7 the measured modal parameters of the two resonances are given as function of the RMS value of the total angular acceleration level.

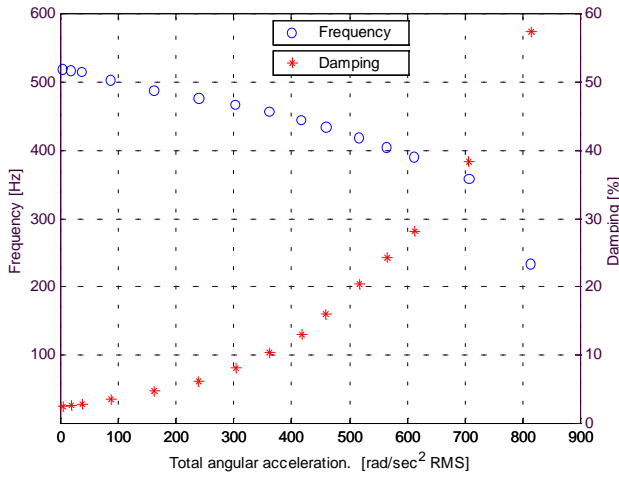

Figure 6: Frequency and damping of first mode measured with random noise

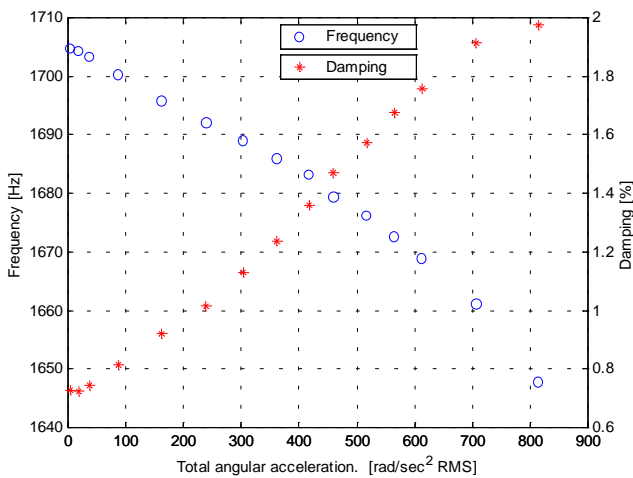

Figure 7: Frequency and damping of second mode measured with random noise

Figure 6 shows a strong influence of the RMS level of the response signal on frequency and damping of the friction induced mode. The influence on the modal parameters of the second mode is much weaker as can be seen in figure 7.

4.2.2 Sine on random measurements

As mentioned in section 2.2 the sine on random excitation signal has a crestfactor of approximately $\sqrt{2}$. The possible influence of the crestfactor and sine frequency on the modal parameters is tested by the two series of measurements as defined in table 1.

The results of the measurements are displayed in figures 8-11 relating the modal parameters to RMS rotation values calculated by double integration of the averaged angular acceleration power spectra.

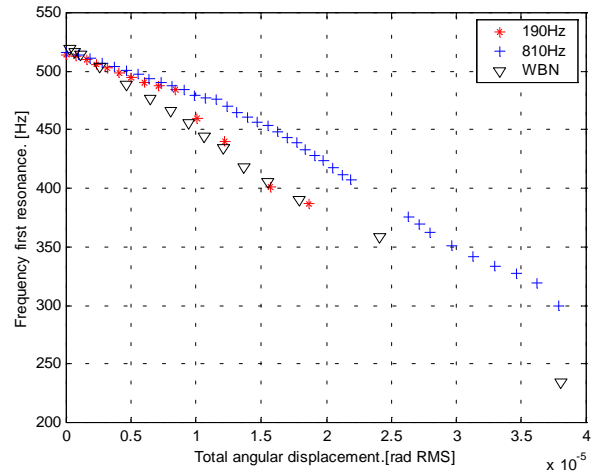

Figure 8: Frequency of first resonance

Figure 8 shows that for comparable rotation levels, the resonance frequency estimates from the 810 Hz sine on random experiment are all higher than the estimates from the noise and 190 Hz sine on random experiments.

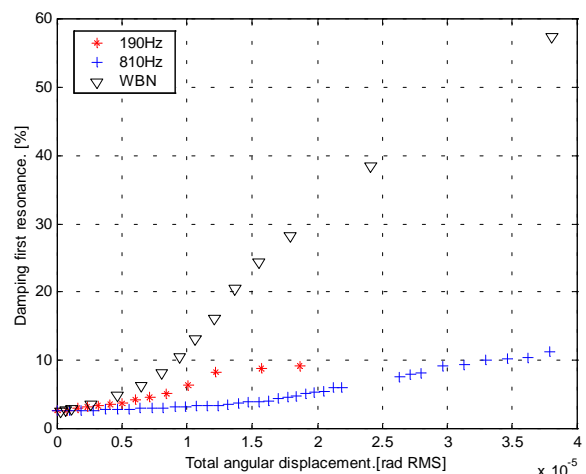

Figure 9: Damping of first resonance

Figure 9 shows a strong difference between the damping estimates from the noise experiment and the results from the sine on random experiments.

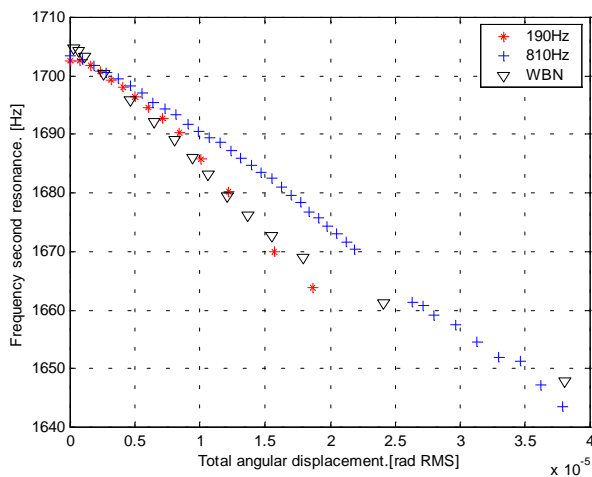

Figure 10: Frequency of second resonance

As in figure 8, the estimates for the frequency of the 1700 Hz resonance have a tendency to be higher than the estimates from the other two experiments

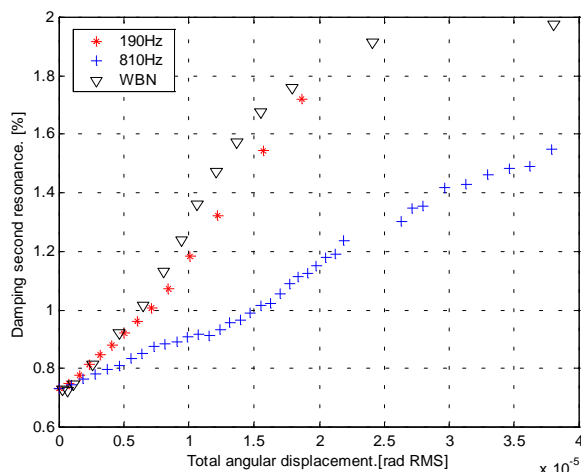

Figure 11: Damping of second resonance.

Unlike in figure 9, figure 11 shows a fairly consistent estimate for the damping of the second resonance based on the noise experiment and the 190 Hz sine on random experiment. Both in figure 9 and 11, the damping estimates from the 810 Hz sine on random experiment are consistently lower than the results from the other experiments.

4.2.3 Reproducibility

Since the stiction behavior in the system is assumed to depend on the shaft angle, all measurements are done with the motor shaft in the same position. The three series of measurements show consistent results

at low values of displacement. Reproducibility of the measurement results however was not tested.

5 Conclusions

This paper demonstrates a frequency domain measurement technique for determining the modal parameters of the friction-induced resonance of a system in its stick-phase. To determine these parameters, frequency response functions are measured between the input of a voltage to current converter and the angular acceleration of the current fed example system. The applied excitation signals are two sine on random signals with different sine frequency and one random noise signal.

Experiments show a significant influence of the type of excitation signal and its RMS value upon the frequency and damping estimates of the stiction induced resonance and the first structural resonance.

The reproducibility of the results is not tested and can be the subject for further work.

References

- [1] R. Hensen *Controlled Mechanical Systems with friction*. Ph.D.Thesis, Eindhoven University of Technology, The Netherlands (2002).
- [2] B. Armstrong-Hélouvy, P. Dupont, and C. Canudas de Wit, *A Survey of Models, Analysis Tools and Compensation Methods for the Control of Machines with Friction*, *Automatica*, 30, (1994), pp.1083-1138.
- [3] C. Canudas de Wit, H. Olsson, K. J. Åström and P. Lischinsky, *A New Model for Control of Systems with Friction*, *IEEE Transactions on Automatic Control*, 40, (1995), pp. 419-425.
- [4] R.H.A. Hensen, M.J.G. van de Molengraft, M. Steinbuch, *Frequency domain identification of dynamic friction model parameters*, *IEEE Trans. on Control Systems Techn.*, 10(2), (2002), pp.191-196.
- [5] D.J. Ewins, *Modal testing: Theory and Practice*, Research Studies Press Ltd. 1986, pp. 148-151.
- [6] Kistler, Type 8832 *Translational-Angular PiezoBEAM (TAP) System*, Data Bulletin K8.8832, 1990.
- [7] SigLab 20-42 dynamic signal analyser system, Spectral Dynamics Inc., *User Guide*.

