

*Università degli Studi di Padova*

*Padua Research Archive - Institutional Repository*

A novel artificial urinary sphincter and comparison with reference device

*Original Citation:*

*Availability:*

This version is available at: 11577/3492561 since: 2023-08-31T08:00:17Z

*Publisher:*

*Published version:*

DOI:

*Terms of use:*

This article is made available under terms and conditions applicable to Open Access Guidelines, as described at <http://www.unipd.it/download/file/fid/55401> (Italian only)

(Article begins on next page)

# A novel artificial urinary sphincter and comparison with reference device

M.V. Mascolini<sup>1,§</sup>, J.V. Fotso Fogang<sup>2,§</sup>, V. Salomoni<sup>3</sup>, C.G. Fontanella<sup>1</sup>, E.L. Carniel<sup>1</sup> and A.N. Natali<sup>1</sup>

<sup>1</sup> Department of Industrial Engineering, University of Padova, Italy

<sup>2</sup> Department of Civil, Environmental and Architectural Engineering, University of Padova, Italy

<sup>3</sup> Department of Management and Engineering, University of Padua, Italy

<sup>§</sup> These authors contributed equally to this work

**Abstract** - Among all the available managements for the stress urinary incontinence, the Artificial Urinary Sphincter (AUS) is clinically considered the first-line treatment by inducing the lumen occlusion through a fluid-inflatable cuff applying a permanent pressure around the urethra.

Over the decades of worldwide implantation of AUS, the success rate has emerged as deeply influenced by the mechanical stimulation of urethral tissues, which may be susceptible to potential degenerative phenomena, to urethral damage, with incontinence and necessary surgical revision.

To minimize the risk of urethral damage, this research work proposes a novel in silico strategy for AUS design, aiming to provide a device that is capable to apply a more uniform and appropriate occlusive action around the urethra.

Computational mechanics analyses are developed to evaluate the interaction between the urethra and the AUS device during the lumen occlusion and its subsequent opening because of bladder induced pressure, aiming to define the design parameters required for the continence condition, according to the tissue tolerability. The functionality of the novel device is compared with the reference AUS AMS800.

**Keywords** - Stress urinary incontinence, artificial urinary sphincter, finite element method, computational structural mechanics

## I. INTRODUCTION

**S**TRESS Urinary Incontinence (SUI) is a widespread pathological condition implying the involuntary leakage of urine in response to increasing intraabdominal pressure (e.g. coughing, sneezing or exercising), due to the deficiency of the urinary sphincteric mechanism. Nowadays, about 400 million people worldwide are affected by urinary incontinence, with SUI accounting for 24% to 45% in women [1] and about 10% in men [2], impacting significantly on quality of life and financial burden.

Since the 1970s, Artificial Urinary Sphincters (AUSs) have been developed for the SUI treatment as prosthetic devices which mimic the functionality of a natural urethral sphincter inducing the lumen occlusion during the storage phase of micturition. The operating principle consists generally in applying a pressure by means of a cuff inflated by saline solution, placed around the bulbar urethra or the bladder neck. Several variants of AUS are on the market and under experimental evaluation, distinguished in terms of control mechanism, pressure transmission and cuff shape and size.

In most cases, the pressure is set in the range 50-80 cmH<sub>2</sub>O [3] and it is defined as a constant value by surgeons during the implantation. The pressure values are based on clinical experience in order to guarantee continence condition in daily situations. To date, despite successful post-surgery outcomes,

the recurrent incontinence following the implantation of AUS is still an open clinical question [4]-[6]. High rates of surgical revision have been reported due to AUS failure because of the reaction of urethral tissues to pressure loading [3], [7]-[9].

In detail, the resulting negative outcome is twofold. First of all, urethral tissue in correspondence to the AUS cuff may undergo degenerative processes in terms of infection, atrophy and/or erosion. In some regions of interaction, tissue could be pinched during the inflation of the cuff and compressive action may cause a hypoxia condition [10]. In case of damaged tissue, the AUS may no longer guarantee the continence condition, even if it was initially adequate. All these complications involve pain and discomfort for the patient that should undergo a new surgery, unless significant tissue damage compromises the implantation of another device. Hence, the application of an artificial urinary sphincter requires a careful evaluation of the interaction phenomena between the device and the biological structures and tissues in contact.

The sphincter is permanently placed around the urethra by continuously applying an occlusive pressure, often higher than what is actually needed, in order to always guarantee continence, even in case of increased abdominal and bladder pressure. Only during voiding phase of micturition, typically around 6-7 times a day, the urethral duct is not exposed to the pressure load. In addition, the AUS is generally placed in urethral regions other than where the natural urethral sphincter is anatomically located and thus the tissues are not physiologically designed to be subjected to such occlusive stress and strain conditions. Therefore, as an essential requirement for the AUS reliability and durability, the biological tissue tolerability has to be necessarily considered in terms of compressive strain, compressive stress and hydrostatic pressure intensity and distribution.

For all these reasons, a novel in silico approach to the design of the AUS device is developed. A computational modelling strategy was defined, allowing to analyse the interaction phenomena between AUS and urethra, and thus to evaluate the device functionality. In detail, the cuff pressure that is required to ensure continence and the mechanical stimulation of urethral tissues, which may induce damage and/or vasoconstriction phenomena, can be evaluated. This approach was exploited to analyse a new AUS, which has been conceived introducing a novel conformation of the cuff as a fluid-inflatable cylindrical chamber to be placed circumferentially around the bulbar urethra.

The in silico procedure required the development of computational models of the male bulbar urethra and the AUS.

Models exploitation made it possible to investigate the urethral mechanical response under different occlusion conditions and intraurethral actions, by varying the material properties of the prosthetic device.

## II. MATERIALS AND METHODS

Over the years, the bioengineering methods provided valid support tools, in a wide range of medical fields, to study the functionality of biological tissues, plan surgical procedures and evaluate the efficacy and reliability of therapies and prosthetic devices. These methods are based on a tight coupling of experimental investigations, including the histomorphometrical and mechanical characterization of biological systems and computational techniques. These latter allow to extend the experimental results to a wider scenario, simulating multiple situations and providing information on relevant aspects that are not accessible by clinical investigation. In this sense, the Computational Structural Mechanics (CSM) approach allowed to interpret the mechanical response of urethral tissue to the lumen occlusion process induced by the artificial sphincter, aiming to evaluate the reliability of the novel device.

### A. Numerical model of the urethral duct

The bulbar urethral model was developed as a fully three-dimensional 50 mm length and 5 mm radius cylinder, with an elliptical lumen defined by internal major and minor axis of 8 and 1.6 mm, respectively (UGS NX3, Siemens PLM Software, Plano, Texas, USA). Lumen shape was previously investigated [10] according to the complex configuration in the bulbar area and here simplified by a regular elliptic shape, as it appears in other urethral regions, and also in consideration of a major pressure requirement for occlusion. Moreover, this shape minimizes the computational effort, suggesting the feasibility of real-time simulations for the surgical practice.

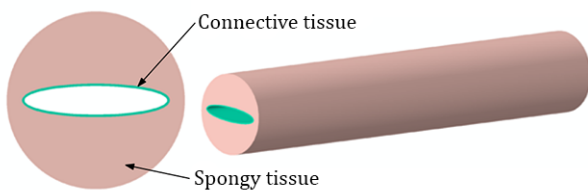

Fig. 1: Geometrical model of the urethral duct as a bi-layered structure.

The urethral wall was assumed to be composed by a thin layer of dense connective tissue that surrounds the lumen and an outer thick layer of spongy tissue all around (Figure 1). The mechanical behaviour of biological tissues was described by a specifically developed hyperelastic formulation [10]. The constitutive parameters were defined on the basis of inverse analysis of experimental data from uni-axial tensile tests and structural inflation tests performed on urethral samples [11].

A tie contact condition on the interfacing surfaces between the two layers and fixed-end constraints on cross-sectional surfaces at the two extremities of the urethral model were imposed to prevent relative and rigid body motion, respectively. The self-contact interaction between lumen surfaces was defined by a hard contact formulation with

friction coefficient of 0.02 [10], [12], [13], considering that the tissue is physiologically wet. The urethral model was finite element discretized assuming different seeds for the two layers, by means of 145,920 and 200,640 linear hexahedral elements, corresponding to 184,000 and 213,440 nodes, respectively for the connective tissue and spongy tissue layers. Discretization was performed in the framework of Abaqus/CAE 6.14 (Dassault Systèmes, Vélizy-Villacoublay, France). To prevent mesh instability, the enhanced hourglass control formulation was adopted [14], [15].

### B. Numerical model of the novel artificial urinary sphincter

The novel prototype of AUS has been conceived with an operating principle based on a hydraulic mechanism, as the majority actually on the market. The inflation of a fluid-filled cuff around the urethra provides for the lumen occlusion. However, on the basis of the current critical issues reported in literature, the novelty lies in the shape of the urethral cuff designed to improve the distribution of the pressure action by wrapping the duct more uniformly and safely, without pinching the tissue. In detail, as a matter of example, a 3D CAD model of the cuff was developed by assembling an inflatable chamber and an external supporting band. Both models were designed as a hollow cylinder with a constant curvature (Figure 2).

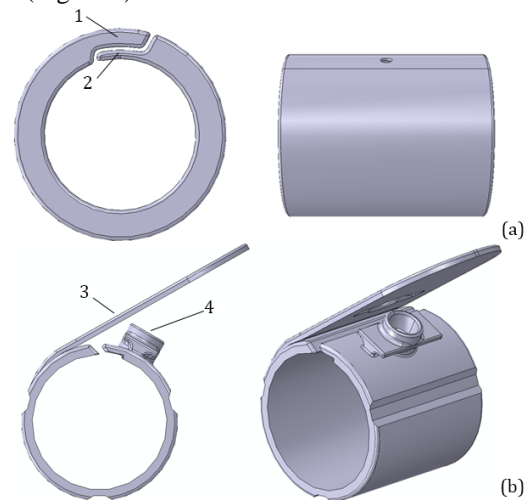

Fig. 2: Geometrical model of the novel artificial urinary sphincter composed by an inflatable chamber (a) and a supporting band (b).

The chamber and the circular band dimensions can be defined on the basis of the specific urethra requirements. In the initial configuration, the chamber end parts, labelled as 1 and 2, are detached and so the cuff is open, as shown in the Figure 2a. In the operative configuration, the band parts, labelled as 3 and 4 in Figure 2b, are intended to come into contact, inducing the closing of the cuff. In this manner, and according to wall stiffness distribution, it is expected that the inner wall of the chamber ensures a circular configuration around the urethra.

Regarding the design of the novel device, a relevant aspect was assumed by the mechanical characterization of its components. An elastomeric material was assumed for both the inflatable chamber and the supporting band, by considering an hyperelastic formulation defined in terms of the strain energy potential as:

$$W(\mathbf{C}) = K_v(J - 1)^2 + C_1(\bar{I}_1 - 3) \quad (1)$$

where  $J$  is the deformation Jacobian,  $\bar{I}_1$  is the first invariant of the iso-volumetric part of the right Cauchy-Green strain tensor  $\mathbf{C}$ ,  $K_v$  is a parameter related to the bulk modulus,  $C_1$  is the material parameter related to the initial shear stiffness as  $\mu_0 = 2C_1$ . Different shear moduli were considered (Material 1, 2 and 3), as reported in Table I. The Material 3 was set to the same stiffness of the most used AUS worldwide, the AMS800 (Boston Scientific, Boston, USA) [10].

**TABLE I: CONSTITUTIVE PARAMETERS**

Material	$C_1$ [MPa]	$K_v$ [MPa]
1	0.20	3.87
2	0.30	5.80
3	0.43	8.31

The contact interaction between the chamber and the band and also between each part was imposed in the normal direction by means of a hard contact formulation, and in the tangential direction with a friction coefficient of 0.1.

The finite element mesh of the supporting band was developed by means of 373,911 four-nodes tetrahedral elements having a mean size of 0.25 mm and a total of 79,182 nodes. On the other hand, the inflatable chamber was meshed by 51,503 three-nodes triangular shell elements, due to its small thickness to area ratio, and a total of 25,759 nodes. The enhanced hourglass control formulation was considered [13], [14].

### C. Computational analyses of lumen occlusion

The two developed models were assembled together by positioning the sphincteric model around the middle region of the urethral duct, as shown in the Figure 3.

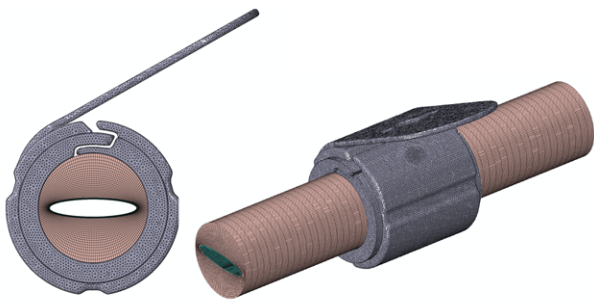

**Fig. 3:** Application of the novel device on the central zone of urethra.

In terms of contact property, a tangential behaviour was defined on the device regions in interaction with the urethral duct by means of friction coefficient of 0.02 [10],[12]. In addition, hard contact was considered in the normal direction on all the surfaces to prevent potential penetration phenomena.

To evaluate the minimum pressure that the novel AUS has to apply on the urethral duct for ensuring the continence, the lumen occlusion induced by the sphincter and the subsequent lumen opening due to the urine action were simulated for different constitutive parameters characterizing the device components. In detail, CSM analyses were performed by a three-step procedure. The first step simulated the cuff closing

by applying a displacement boundary condition to carry the band tab portion in the operative positioning. Subsequently, during the second step, the chamber was inflated to a target pressure. Holding constant the occlusive action, during the third step, a radial pressure on the lumen inner surface was progressively increased up to the lumen opening.

The occlusive and intraluminal pressures were applied by means of hydrostatic pressure conditions. Load uniform distribution and velocity of 400 cmH<sub>2</sub>O/s were assumed. Different target values of cuff pressure were considered in the range between 0 and 80 cmH<sub>2</sub>O, on the basis of the occlusive pressure applied by the current AUSs. With regards to the urine action, the intraluminal pressure was considered within the physiological range during the voiding phase of micturition [16]. Since geometrical non-linearity effects and complex contact and self-contact conditions were expected during the analysis, the Abaqus/Explicit 6.14 (Dassault Systèmes, Vélizy-Villacoublay, France) non-linear dynamic explicit solver was adopted. The analyses were performed using a HPC server equipped with four Intel Xeon E7-8890 v4 and 512 GB RAM, allocating 30 to 50 threads for each target cuff pressure's simulation, resulting in an average analysis duration of 72 hours for each simulation.

### III. RESULTS

The in silico approach to AUS design was exploited to investigate a novel device.

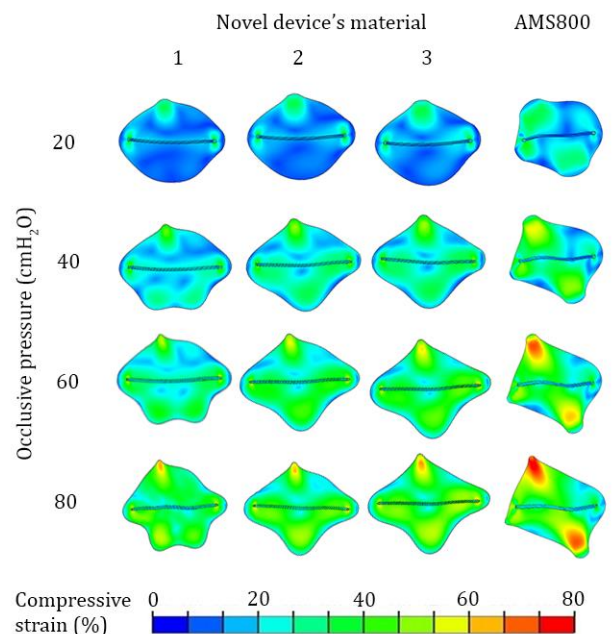

**Fig. 4:** Contours of compressive strain field at different level of cuff pressure for the different materials of the novel AUS and for the AMS800.

Numerical results of interaction phenomena between the urethral duct and the novel AUS were analysed during the lumen occlusion and opening processes considering different material parameters characterizing the device's components.

In particular, the compressive strain fields on the section of maximum stimulation of urethral model are reported for different occlusive pressures, as 20, 40, 60 and 80 cmH<sub>2</sub>O, in relation with the three materials considered (Figure 4). In

comparison, the same mechanical fields for the AMS800 device are reported [10]. The results highlight an increase of compressive strain, proportional to the value of the applied cuff pressure and dependent on cuff material.

While minor difference emerges between the different materials of the novel device, it can be noted that, comparing them to the AMS800, less extensive areas are subjected to high values of compressive strain for occlusive pressures higher than 60 cmH<sub>2</sub>O. This is an important aspect to consider because high values of compressive strain (and so of compressive stress) entail a risk of tissue degenerative phenomena. Moreover, for an occlusive action of 80 cmH<sub>2</sub>O, the AMS800 involves more regions of urethra under hydrostatic pressures above 70 cmH<sub>2</sub>O, which can obstruct most of the urethral vessels, where the blood flow reaches pressures between 13 and 105 cmH<sub>2</sub>O [10].

For each material, the analyses allowed studying the relationship between sphincteric loading and urine action required to open the lumen. In particular, for each cuff material and each cuff pressure the corresponding lumen opening pressure was defined as the minimum intraluminal pressure needed to open the urethra. The resulting curves for the novel device are reported in Figure 5, in comparison to AMS800.

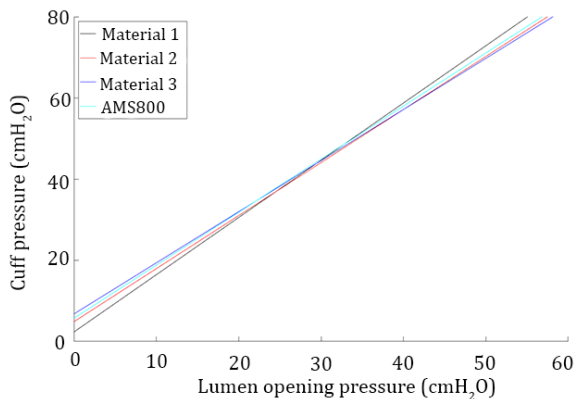

Fig. 5: Relation between lumen opening pressure and cuff pressure.

#### IV. CONCLUSION

AUS device is the gold standard treatment for severe SUI, with particular regard to male subjects. Nonetheless, the non-physiological mechanical effects on urethral tissues frequently entails complications. Aiming to a more reliable approach, a novel AUS has been defined by means of in silico methods, also supported by experimental tests. The methodology allows analysing interaction phenomena between AUS and urethral tissues and structure. The main outputs of the investigation consist in: i) the trend of cuff pressure that is required to ensure continence depending on bladder induced pressure, as a measure of functionality of the device, ii) the mechanical stimulation of urethral tissues depending on cuff pressure, in relation with the potential damage and/or vaso-constriction phenomena. The analysis shows that all the material configurations of the novel device have almost the same continence performance as the AMS800 (Figure 5). On the other side, it appears that the novel AUS device improves the distribution of the mechanical action on urethral tissues compared to the reference AUS case (Figure 4).

Even if supported by specific experimental tests, economic and time costs of the computational approach appears affordable and reliable, also overcoming ethical tasks. It represents a relevant support for clinical-surgical practice in the evaluation of the most appropriate solution to be adopted. The flexibility of the approach also leads to the possibility of prompt analysis of specific cases proposed for surgery.

#### ACKNOWLEDGEMENT

This work was supported by University of Padova, Project FONT\_BIRD2020\_01 “Characterization of Artificial Urinary Sphincters for the identification of new DEVICES (AUS-DEV)”.

#### REFERENCES

- [1] L. N. Tran and Y. Puckett, “Urinary incontinence”, *StatPearls* [Online], Treasure Island FL, 2022 Available: <https://www.ncbi.nlm.nih.gov/books/NBK559095/>
- [2] R. Bientinesi, S. M. Recupero, G. Palermo, D. D’Agostino, P. F. Bassi et al., “Surgery for Male Urinary Incontinence: Where are we now and what is in the Pipeline?”, *Urologia Journal*, vol. 82, pp. 139-150, December 2014
- [3] I. Toniolo, M. V. Mascolini, E. L. Carniel and C. G. Fontanella, “Artificial sphincters: An overview from existing devices to novel technologies”, *Artificial Organs*, November 2022
- [4] A. Srivastava, G. A. Joice, H. D. Patel, M. G. Manka, N. A. Sopko et al., “Causes of Artificial Urinary Sphincter Failure and Strategies for Surgical Revision: Implications of Device Component Survival”, *European Urology Focus*, vol. 5, pp. 887-893, September 2019
- [5] B. J. Linder, L. J. Rangel and D. S. Elliott, “Evaluating Success Rates After Artificial Urinary Sphincter Placement: A Comparison of Clinical Definitions”, *Urology*, vol. 113, pp. 220-224, March 2018
- [6] S. Bugeja, S. L. Ivaz, A. Frost, D. E. Andrich and A. R. Mundy, “Urethral atrophy after implantation of an artificial urinary sphincter: fact or fiction?”, *BJU International*, vol. 117, pp.669-676, April 2016
- [7] L. Marziale, G. Lucarini, T. Mazzocchi, E. Gruppioni, S. Castellano et al., “Artificial sphincters to manage urinary incontinence: a review”, *Artificial Organs*, vol. 42, pp 215-233, August 2018
- [8] D. K. Agarwal, B. J. Linder and D. S. Elliott, “Artificial urinary sphincter urethral erosions: Temporal patterns, management, and incidence of preventable erosions”, *Indian Journal of Urology*, vol. 33, pp. 26-29, January 2017
- [9] N. A. Chertack, K. M. Caldwell, G. A. Joice, M. Kavoussi, B. M. Dropkin et al., “Long-term lower urinary tract sequelae following AUS cuff erosion”, *Neurourology and Urodynamics*, vol. 41, pp. 229-236, September 2021
- [10] A. N. Natali, E. L. Carniel and C. G. Fontanella, “Investigation of interaction phenomena between lower urinary tract and artificial urinary sphincter in consideration of urethral tissues degeneration”, *Biomechanics and Modeling in Mechanobiology*, vol. 19, pp. 2099-2109, May 2020
- [11] A. N. Natali, E. L. Carniel, A. Frigo, P. G. Pavan, S. Todros et al., “Experimental investigation of the biomechanics of urethral tissues and structures”, *Experimental Physiology*, vol. 101, pp. 641-656, May 2016.
- [12] C. G. Fontanella and E. L. Carniel, “Computational Tools for the Investigation of the Male Lower Urinary Tract Functionality in Health and Disease”, *Journal of Medical and Biological Engineering*, vol. 41, pp. 203-215, March 2021
- [13] J. F. Prinz, R. A. de Wijk and L. Huntjens, “Load dependency of the coefficient of friction of oral mucosa”, *Food Hydrocolloids*, vol. 21, pp. 402-408, May 2007
- [14] T. Belytschko and L. P. Bindeman, “Assumed strain stabilization of the eight node hexahedral element”, *Computer Methods in Applied Mechanics and Engineering*, vol.105, pp. 225-260, June 1993
- [15] M. A. Puso, “A highly efficient enhanced assumed strain physically stabilized hexahedral element”, *International Journal for Numerical Methods in Engineering*, vol. 49, pp. 1029-1064, September 2000
- [16] S. Zheng, D. Carugo, A. Mosayyebi, B. Turney, F. Burkhard et al., “Fluid mechanical modeling of the upper urinary tract”, *WIREs Mechanism of Disease*, vol.13, November 2021