

## NON-DISMANTLING CONTROL POSSIBILITIES OF DISTRIBUTED SYSTEMS MEASURING CHANNELS IN-SITU OPERATION PLACE

Tetiana Bubela<sup>1</sup>, Vasyl Yatsuk<sup>1</sup>, Mykola Mykyjchuk<sup>1</sup>, Yuriy Yatsuk<sup>2</sup>

Lviv Polytechnic National University, <sup>1</sup> Information Measuring Technologies Department, <sup>2</sup> Computerised Automation Systems Department, 12, Bandera Street, 79013, Lviv, Ukraine

### ABSTRACT

In this work the structure of a multi-value and multi-range voltage measure with automatic correction of the additive error component is proposed and analyzed. Their used possibilities for the calibration of measuring channels of distributed systems on-situ exploitation are discussed. It is shown that the limit value of the uncorrected additive error component for modern elements will be several tens of nanovolts.

**Index Terms** – Voltage measure, Distributed systems, Measuring channels, Automatic additive error correction

To implement the concept of the European metrological cloud in distributed measuring devices, it is necessary to correctly carry out the non-dismantling calibration of the measuring channels at the place of operation. At the same time, it is advisable to separately calibrate the sensors and measuring channels of the distributed measuring means, starting from the sensor output and ending with the technical means for displaying of the measured quantity values for a given configuration of the entire measuring circuit. For on-site calibration of low-level direct current voltage measuring channels, it is recommended to use portable calibrators with automatic additive error component (AEC) correction (see figure).

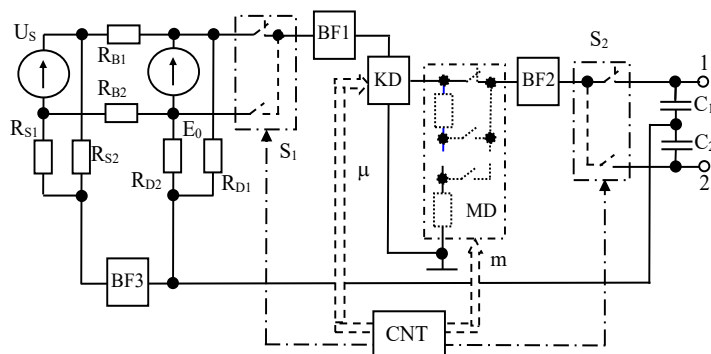

Fig.1. Block diagram of a low-level DC voltage calibrator

The principle of error correction consists in the formation of a bipolar calibrator input voltage from the unipolar output signal of the sample voltage source and the subsequent transformation of these signals at different times, their demodulation and storage on a pair of output capacitors. As a result, the equivalent AEC of the voltage calibrator for any values of the control codes and reproduction sub-bands is stored and corrected at different times and with different signs on both memory capacitors.

The DC voltage calibrator provides the possibility of operation from a bipolar and unipolar power supply unit. The reference voltage source  $E_0$  is turned on as a "floating" stabilizer with the formation of two output voltages  $E_{01}$  and  $E_{02}$  of opposite polarity relative to the common bus of the calibrator. At the same time, the potential of the common bus  $U_{S0}$  is

approximately equal to half of the supply voltage and is formed by the resistive divider  $R_{S1}$ ,  $R_{S2}$  and the buffer repeater BF3. For a bipolar power source  $U_S$ , the sum of positive and negative voltages  $U_{S1}+U_{S2}=0$  and, accordingly, the voltage  $U_{S0}\approx 0$  will be close to zero, and for a unipolar power supply  $U_S$  this voltage will be approximately  $U_{S0}\approx U_S/2$ , provided that  $R_{S1}\approx R_{S2}$ .

The output voltage of the calibrator is formed as an algebraic sum of the voltages  $U_{C1}$ ,  $U_{C2}$  on the capacitors  $C_1$  and  $C_2$  in different half-cycles of the control voltage of the polarity switches  $S_1$  and  $S_2$ . In the first and second half-cycles of the voltage control signal  $U_{C1}$ ,  $U_{C2}$  will be determined, respectively, as:

$$U_{C1} = U_{BF21} + I_{DS21}r_{S21}, \quad (1)$$

$$U_{C2} = U_{BF22} + I_{DS22}r_{S22}, \quad (2)$$

where  $U_{BF21}$ ,  $U_{BF22}$  - output voltages of the voltage buffer, respectively, in one and the other half-cycle of the control signal,  $I_{DS21}$ ,  $I_{DS22}$ ,  $r_{S21}$ ,  $r_{S22}$  - accordingly, the reverse currents of the drain-substrate and the source-substrate junctions and the resistances of the closed upper key  $S_{21}$  and  $S_{22}$  of the switch keys  $S_2$  (as the figure shown),  $e_{11}$ ,  $e_{12}$  are equivalent to the AEC in the first and second half-cycles,  $U_{BF11} = \{[(E_0R_{D1}/(R_{D1} + R_{D2}) + U_{S0} + e_{11e})\mu(1 + \delta_1) + e_{1\mu}] + e_{31e}\}m_j(1 + \delta_3)$ ,  $U_{BF12} = \{[-E_0R_{D2}/(R_{D1} + R_{D2}) + U_{S0} + e_{12e})m_j(1 + \delta_1) + e_{1\mu}] + e_{31e}\}(1 + \delta_3)$ ,  $\delta_1$ ,  $\delta_3$  - non-ideality errors of buffer amplifiers BF<sub>1</sub>, BF<sub>2</sub>,  $e_{BF1}$ ,  $I_{BF1}$ ,  $k_{BF1}$ ,  $M_{BF1}$  - respectively, the bias voltage, the input current of the non-inverting input, the transmission factor, and the common-mode rejection ratio of the first voltage buffer BF<sub>1</sub>,  $R_{D1}$ ,  $R_{D2}$  - resistances of stable resistors,  $\mu$  - control code of the code-controlled voltage divider,  $m_j$  - the division factor of the large-scale controlled voltage divider.

The output voltage  $U_k$  of the DC voltage calibrator will be determined as the algebraic sum of the voltages in both half-cycles on the storage capacitors  $C_{11}$  i  $C_{12}$ :

$$U_k = U_{C1} - U_{C2} = (E_0\mu m_j + e_k) \left(1 + \frac{1}{k_\mu}\right) \left(1 + \frac{1}{k_2} + \frac{1}{M_{BF2}}\right) \left(1 + \frac{1}{k_3} + \frac{1}{M_{BF3}}\right), \quad (3)$$

where  $e_k = (I_{DS21}r_{S21} - I_{DS22}r_{S22}) + (I_{DS11} + I_{DS12} + I_{BF1})[(R_{01} - R_{02}) + (r_{S21} - r_{S22})] + (I_{DS11}R_{01} - I_{DS12}R_{02})$ ,  $R_{01} = R_{D1}r_{S21}/(R_{D1} + R_{D2})$ ,  $R_{02} = R_{D2}r_{S22}/(R_{D1} + R_{D2})$ .

It is necessary to evaluate the limit unadjusted value of AEC of the voltage calibrator with automatic error correction. If you choose for implementation, for example, such a serial element base, a reference voltage source  $E_0$ , microcircuits LTC6652, LT1389, LT1389, operational amplifiers for voltage buffers, types ADA4625-1, LTC2058, LT6274/LT6275, microcircuits of switches of the type ADG1636. Then, in the operating temperature range (-40...+125) °C, the maximum value of the uncorrected AEC voltage calibrator with error correction will not exceed only  $\pm 38$  nV.

**Conclusion** The analysis showed that the limit value of the additive error component in DC voltage calibrators with automatic correction will be only a few tens of nanovolts. The proposed structure of the DC voltage calibrator can be used as a portable unit for calibrating the DC voltage measuring channels of distributed systems to realize the concept of the European metrology cloud.

## CONTACTS

Prof. Dr.-Sc. T. Bubela

email: [tetiana.z.bubela@lpnu.ua](mailto:tetiana.z.bubela@lpnu.ua)

ORCID: <https://orcid.org/0000-0002-2525-9735>

Prof. Dr.-Sc. V. Yatsuk

email: [vasyl.o.yatsuk@lpnu.ua](mailto:vasyl.o.yatsuk@lpnu.ua)

ORCID: <https://orcid.org/0000-0002-4213-4862>

Prof. Dr.-Sc. M. Mykyjchuk

[mykola.m.mykyjchuk@lpnu.ua](mailto:mykola.m.mykyjchuk@lpnu.ua)

ORCID: <https://orcid.org/0000-0002-0591-6304>

As. Prof. PhD Y. Yatsuk

email: [yurij.v.yatsuk@lpnu.ua](mailto:yurij.v.yatsuk@lpnu.ua)

ORCID: <https://orcid.org/0000-0003-3915-3058>