

Detecting ultra-high energy cosmic rays from space with unprecedented acceptance: objectives and design of the JEM-EUSO mission

M. Casolino^{1,2}, J. H. Adams^{5,6}, M. E. Bertaina³, M. J. Christl^{5,6}, T. Ebisuzaki², P. Gorodetzky⁷, Y. Hachisu², F. Kajino⁴, Y. Kawasaki², G. Medina-Tanco⁹, H. Miyamoto², H. Ohomori², E. Parizot⁷, I. Park¹³, P. Picozza^{10,2}, N. Sakaki¹¹, A. Santangelo⁸, K. Shinozaki², Y. Takizawa², K. Tsuno², and JEM-EUSO collaboration¹²

¹INFN, Structure of Rome Tor Vergata, Via Della Ricerca Scientifica 1, 00133, Rome, Italy

²RIKEN Advanced Science Institute, Wako 351-0198, Japan

³University of Torino, Dept. of Physics and INFN, Structure of Torino, Italy

⁴Department of Physics, Konan University, Kobe 658-8501, Japan

⁵Marshall Space Flight Center, NASA, Huntsville, AL 35812, USA

⁶Department of Physics, The University of Alabama in Huntsville, AL 35899, USA

⁷APC - AstroParticule et Cosm. CNRS: UMR7164-CEA-IN2P3 - Observ. de Paris, Univ. Denis Diderot - Paris VII, France.

⁸Inst. für Astronomie und Astrophysik, Kepler Center for Astro and Part. Physics, Eberhard Karls Uni. Tübingen, Germany.

⁹Instituto de Ciencias Nucleares (ICN), Universidad Nacional Autonoma de Mexico, Mexico D.F.

¹⁰University of Rome Tor Vergata, Dept. of Physics, Rome, Italy

¹¹Aoyama Gakuin University, Dept. of Physics and Mathematics, Tokyo, Japan

¹²<http://jemeuso.riken.jp/en/index.html>

¹³Department of Physics, Ewha Womans University, Seoul 120-750, Korea

Received: 22 November 2010 – Revised: 13 February 2011 – Accepted: 15 February 2011 – Published: 26 October 2011

Abstract. The Extreme Universe Space Observatory on the Japanese Experiment Module (JEM-EUSO) of the International Space Station (ISS) is the first mission that will study from space Ultra High-Energy Cosmic Rays (UHECR). JEM-EUSO will observe Extensive Air Showers (EAS) produced by UHECRs traversing the Earth's atmosphere from above. For each event, the detector will make accurate measurements of the energy, arrival direction and nature of the primary particle using a target volume far greater than what is achievable from ground. The corresponding increase in statistics will help to clarify the origin and sources of UHECRs as well as the environment traversed during production and propagation. Possibly this will bring new light onto particle physics mechanisms operating at energies well beyond those achievable by man-made accelerators. The spectrum of scientific goals of the JEM-EUSO mission includes as exploratory objectives the detection of high-energy gamma rays

and neutrinos, the study of cosmic magnetic fields, and tests of relativity and quantum gravity effects at extreme energies. In parallel JEM-EUSO will systematically perform observation of the surface of the Earth in the infra-red and ultra-violet ranges, studying also atmospheric phenomena (Transient Luminous Effects). The apparatus is a 2t detector using Fresnel-based optics to focus the UV-light from EAS on a focal surface composed of about 6 000 multianode photomultipliers for a total of $\approx 3 \cdot 10^5$ channels. A multi-layer parallel architecture has been devised to handle the data flow and select valid triggers, reducing it to a rate compatible with downlink constraints. Each processing level filters the event with increasingly complex algorithms using ASICs, FPGAs and DSPs in this order to reject spurious triggers and reduce the data rate.



Correspondence to: M. Casolino
(casolino@roma2.infn.it)

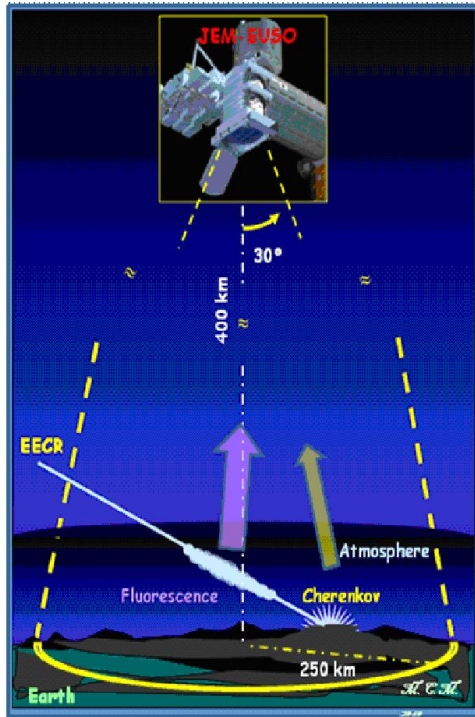

Fig. 1. Artistic view of the JEM-EUSO principle of observation. The telescope detects from the ISS both fluorescence and Cherenkov light, produced by the EAS of UHECR through the atmosphere.

1 Introduction

JEM-EUSO is a Fresnel-optics refractive telescope devoted to the observation of Ultra High Energy Cosmic Rays showers in the Earth's atmosphere (Kajino, 2010). This remote-sensing instrument will orbit the Earth every $\simeq 90$ min on board of the International Space Station (ISS) at an altitude of $\sim 330 - 400$ km. Its goal is the study of the sources of UHECR and the determination of the origin and nature of these particles with high precision, thanks to the increase in statistics due to the larger exposure. The observation principle (see Fig. 1) is the detection of fluorescence light emitted by particles showering in the atmosphere.

2 Scientific objectives

The scientific goals of JEM-EUSO are described in detail by Takahashi and the JEM-EUSO Collaboration (2009); Ebisuzaki et al. (2008). Here we just mention the main objectives:

- Identification of the sources of UHECR by high statistics and analysis of the arrival direction.

- Measurement of the flux and energy spectra of different sources; search for features (pile-up bump, recovery at higher energies) in the spectral shape.
- Identification of the astrophysical nature of the sources emitting UHECR.
- Understanding and constraining the production, emission and acceleration mechanisms of ultra high energy cosmic rays.
- Probe the galactic and local intergalactic structure of magnetic fields.
- Probe multiple anisotropies that could result from large scale nearby cosmic structure and/or subdominant components in the ultra high energy particle flux (such as decay of super-heavy relics in the Galactic halo or high-energy neutrino annihilation on the relic neutrino background - the Z-burst mechanism).
- Probe the GZK intensity profile of distant sources and the temporal evolution of cosmic ray activity in the near Universe.

Other Exploratory objectives include:

- Separation of neutrinos and gamma rays from nucleons and nuclei (Santangelo et al., 2010).
- Potential break-through in neutrino astronomy through the detection of cosmogenic neutrinos.
- Theoretically challenging acceleration mechanisms to 10^{21} eV.
- Test Super Heavy Dark matter models, Z-burst models and other non-conventional mechanisms.
- Search for new physics.
- Constraint of extra-dimension model via detection of ultra high energies neutrinos. Constraint of UHE neutrino cross sections.
- Test of relativity at ultra high energies.
- Super-LHC physics: exploration of high energy physics beyond the accelerator limit.

In parallel to the high energy physics, a number of atmospheric science issues will be addressed:

- Earth Observation in the infra-red and ultra-violet frequencies. Creation of ground maps.
- Understanding space-atmosphere interactions and possibly related climate changes.
- Interaction of dust in the atmosphere.
- Understanding Transient Luminous Effects (Elves, Sprites, Terrestrial Gamma Flashes...).
- Study of meteoroids and associated phenomena.

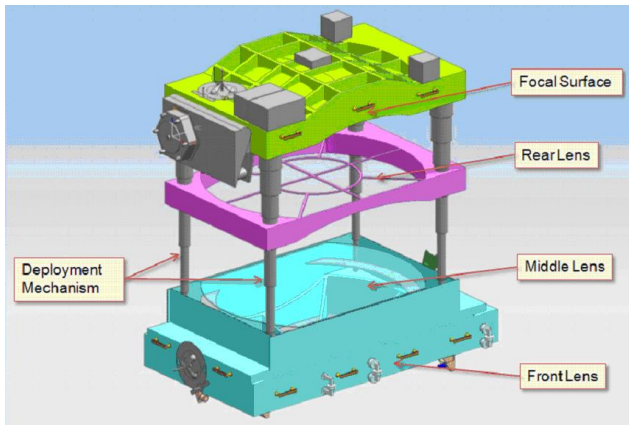

Fig. 2. CAD model of the JEM-EUSO structure. The detector is attached to the ISS through the focal surface. The front lens (on bottom of the picture) looks toward Earth (Courtesy of IHI).

3 Detector characteristics and principle of observation

JEM-EUSO (see Fig. 2) will observe from space the Earth’s night atmosphere. It will measure the UV (300 – 400 nm) fluorescence tracks and the Cherenkov reflected signal of the Extensive Air Shower induced by UHECR interaction in the atmosphere. JEM-EUSO captures and reconstructs the temporal and spatial evolution of the track through the fluorescent UV photon component of the EAS in the atmosphere. The light is focused through a Fresnel lens diffractive optics with a wide field-of-view ($\pm 30^\circ$). The light is detected by the focal plane electronics which records the track of the EAS with a time resolution of $2.5\mu\text{s}$ and a spatial resolution of about 0.75 km (corresponding to 0.1°). These time-segmented images allow to determine the energies and directions of the primary particles.

Figure 3 shows a simulation of the time profile of photons (of fluorescence and Cherenkov origin) as observed from JEM-EUSO. The instrument can reconstruct the incoming direction of the extreme energy particles with accuracy better than several degrees. The instantaneous geometrical area is (in nadir pointing mode) a circle of 500 km diameter, which converts to an instantaneous aperture of $6 \cdot 10^5 \text{ km}^2 \text{ sr}$. The atmospheric mass monitored, assuming the 60-degree field-of-view, is about $1.7 \cdot 10^{12} \text{ t}$. The target mass for upward neutrino detection is $\sim 5 \cdot 10^{12} \text{ t}$. The JEM-EUSO observational method is shown in Fig. 1. A particle of $E \simeq 10^{20} \text{ eV}$ particle penetrating the Earth’s atmosphere has an interaction length of $\sim 40 \text{ g/cm}^2$ and generates a shower of secondary particles. The number of these secondary particles ($N \simeq 10^{11}$) is proportional to the shower maximum and is largely dominated by electrons/positrons. The total energy carried by the charged secondary particles is converted into fluorescence photons through the excitation of the air nitrogen molecules. The fluorescence light is isotropic and proportional to the number of charged particles in the EAS.

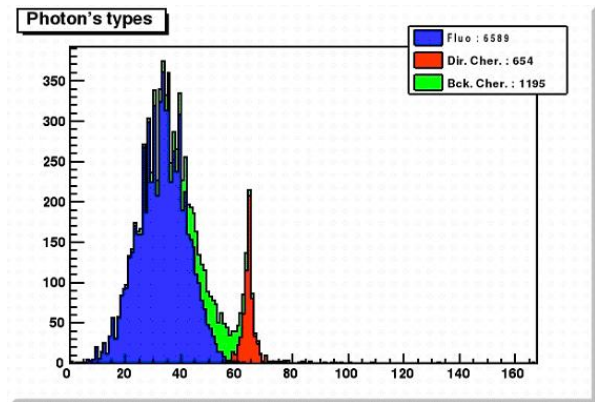

Fig. 3. Time profile of photons from a typical EAS. It is possible to see the contribution of the three components (UV light -blue, Cherenkov peak - red, scattered Cherenkov - green) and their time profile.

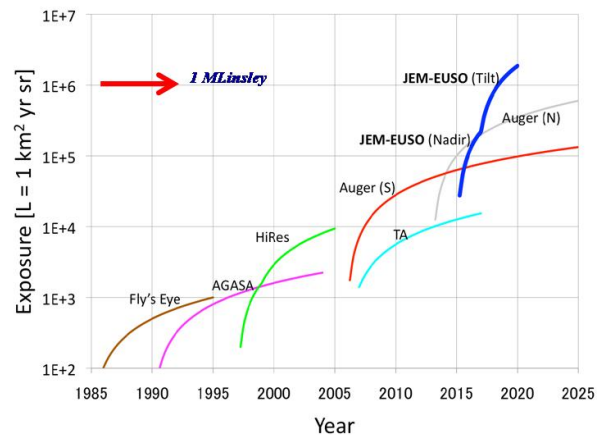

Fig. 4. Expected cumulative exposure of JEM-EUSO (at $\simeq 3 \times 10^{20}$) compared with other ground-based experiments. The baseline flight-plan is based on a launch in 2015, two years in nadir pointing and three years in tilted mode.

The instrument is designed to reconstruct the incoming direction of the ultra high-energy particles with an accuracy better than a few degrees.

The size of the instantaneous geometrical area (shown in Fig. 4) depends on the tilt of the telescope, the angle between the telescope axis and nadir. The increase of geometrical area from the nadir mode to the tilted mode is a factor of 2 – 5 and depends on the energy of the events.

The depth of maximum development of a shower (X_{max} , expressed in g/cm^2) increases with energy. For a given energy, the value of X_{max} provides information on the nature of the primary particle. The JEM-EUSO objective is to reach a X_{max} resolution of $\simeq 120 \text{ g/cm}^2$, which is comparable to the differences in X_{max} between showers initiated by protons and by Fe nuclei, making a distinction between protons and Fe nuclei with this kind of experiments possible.

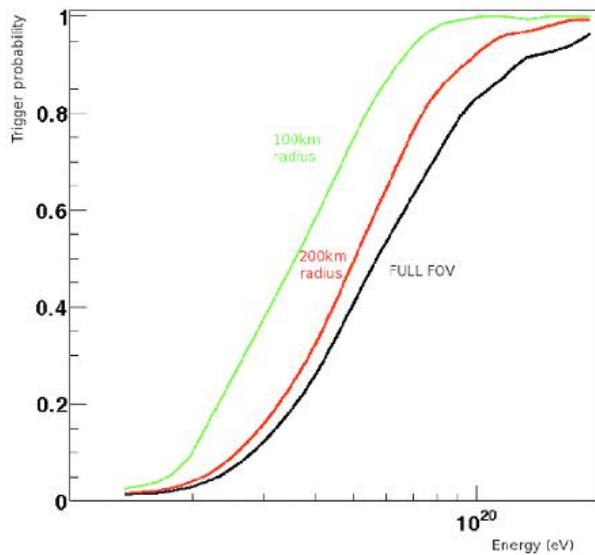

Fig. 5. On-board trigger efficiency for JEM-EUSO: the green and red curves refer to events contained in a 100 km and 200 km fiducial core.

4 Instrument Performance

4.1 Trigger efficiency

In nadir mode, the geometry of the detection is optimal, since the distance of the showers to the instrument is smaller and the amount of atmosphere crossed is minimal. Furthermore the field of view projected on the ground of a pixel of the focal surface is smallest. For a given energy and angle of impact the showers leave a larger track in the instrument (angle and / or time), and send more light to the focal surface. In addition, the showers closest to the nadir of the instrument use the lens system along its axis, where performance is greatest. The result is greater efficiency at low energy. It is important to note that the cosmic ray flux decreases rapidly with increasing energy, and the required acceptance at low energy is less than that required for the highest energies. Thus, even if more stringent geometrical observing conditions are needed at low energies, the improved resolution coupled with the higher flux will accumulate significant statistics at the lowest energies ($4 - 5 \cdot 10^{19}$) where the flux is higher (see Fig. 5). Above these energies the amount of light emitted is larger and the detection of showers easier. The instrument can be therefore used in an off-axis (tilted mode) configuration to increase the maximum total acceptance. In tilted mode, the surface on ground observed by the instrument increases in the direction of the inclination relative to nadir.

4.2 Energy resolution

The quality of the reconstruction of showers (energy, incoming direction...) depends on the orientation of the shower

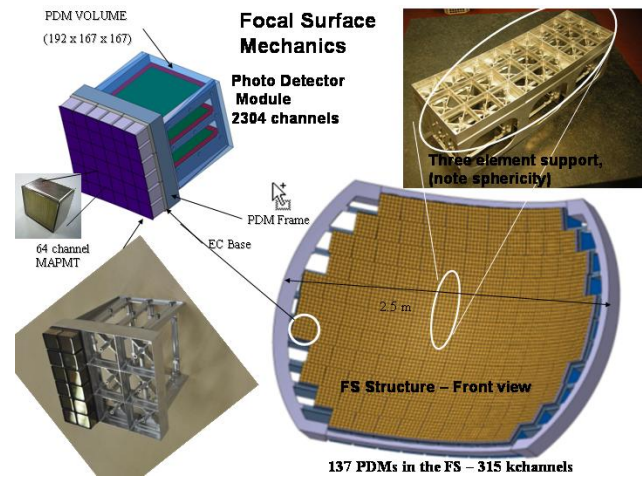

Fig. 6. Bottom Right: Mechanical structure of the focal surface. The 2.5 m plane is divided in 137 PDM modules. Each PDM (Top Left) contains 36 Multi-Anode Photomultipliers (Hamamatsu Ultra-Bialkali R11265-64), each with 64 independent channels. The bottom left corner shows the prototype of the mechanical structure with two rows of 12 PMT installed. In the Top Right corner a sub-element of support beams containing three PDM is shown.

and its position relative to the instrument. The energy resolution is better than 30%, improving with energy and for tracks more inclined with respect to the atmosphere. Beyond 10^{20} eV showers can be reconstructed with an accuracy of 15% in energy (excluding systematics).

5 Focal surface electronics

The JEM-EUSO focal surface (see Fig. 6) consists of more than 300 kchannels, arranged in 137 modules (PDM modules) each consisting of 36 Hamamatsu Ultra-Bialkali R11265-64 Multi-Anode Photomultipliers, each with 64 channels. The fluorescence light of the shower is sampled with a time resolution of $2.5 \mu\text{s}$ (defined as a Gate Time Unit, GTU) and spatial resolution of about 0.75 km (corresponding to a granularity of 0.1°). These time-sliced images (see Fig. 3) allow determining the energy and direction of the primary particles.

6 Electronics

The data acquisition and handling system is designed to maximize detector observation capabilities to meet the various scientific goals, monitor system status, autonomously taking all actions to maintain optimal acquisition capabilities and handle off-nominal situations. CPU and electronics are based on hardware successfully employed in space experiments such as PAMELA, Altea, Sileye-3, etc., taking into account recent developments in microprocessors and FPGA technol-

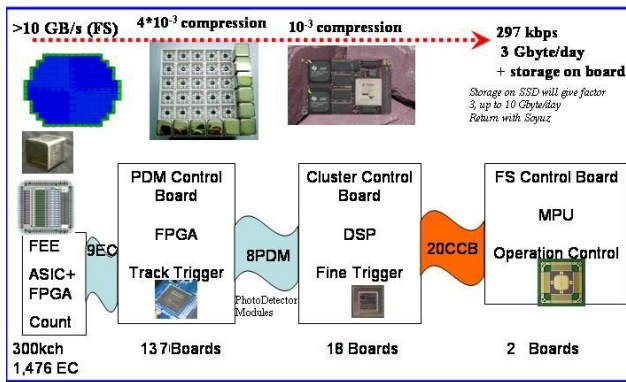

Fig. 7. Data Reduction scheme. Each of the $\simeq 6000$ Multi-Anode Photo Multiplier (MAPMT) of the focal surface is read by an ASIC digitizing the photoelectron signal. A 6×6 array of MAPMT is present and read by each of the 137 PDM modules, where an FPGA performs first level triggering and rejects noise by three orders of magnitude. 8 PDMs are read by a Cluster Control Board, each with an high performance DSP which rejects noise by other three orders of magnitude. The general acquisition and data storage is performed by the main CPU (right).

ogy. Acquisition techniques and algorithms are also derived from the technological development performed in these missions. Rad-hard technology will be employed, with ground beam tests at accelerator facilities such as GSI, Dubna, HIMAC to qualify and test resistance of new devices. Space qualified devices will be employed for mission-critical items.

The general approach is to use off-the-shelf technologies in the development of the laboratory models and breadboard systems to refine and test the various trigger and data reduction algorithms in parallel to hardware development and construction. The same approach will be followed in the use of communication protocols and interfaces (e.g. VHDL, spacewire, 1553, 1355 protocols) and in the realization of the ground support equipment. This will allow for a fast development of the software in parallel to the engineering and production of flight boards, reducing costs and integration time.

Hot/Cold redundancy will be implemented in all systems and in all stages of data processing with the exception of intrinsically redundant devices such as the focal surface detectors.

6.1 Data Acquisition and Reduction

The Data acquisition system (Fig. 7) is based on an architecture capable of reducing at each level the amount of data through a series of triggers controlling an increasingly growing area of the focal surface (Casolino, 2010). It is necessary to reduce the 10 Gbyte/s output on the focal surface (FS) to the 3 Gbyte/day which can be downlinked on the ground. Each board and data exchange protocol is compliant to han-

dle the data and send them to the higher level of processing if they satisfy the trigger conditions.

An ASIC chip performs photo-electron signal readout and conversion for the 64 channels of the MAPMT. An FPGA handles first level trigger data on a PDM level (reading 36 MAPMTs). The data are stored in a 100 GTU buffer (each GTU corresponds to a $2.5 \mu\text{s}$ frame, for a total sampling of $250 \mu\text{s}$) upon which the triggering and noise reduction algorithms are implemented. Background events are rejected by a factor 10^3 . Second level triggering algorithms are implemented by the 18 CCB (Cluster Control Boards), DSPs with about 1Gflop computing capability which further process triggers coming from 8 PDMs. At this level background is rejected by another factor 10^3 . The CPU has a relatively low processing power (100 MHz) since it is charged of the general handling of the experiment. The CPU is part of the Storage and Control Unit System (SCU), the evolution of a similar system used for PAMELA (Casolino et al., 2006) and composed of a number of boards devoted to different tasks: 1. CPU mainboard 2. Mass Memory (8 Gbyte) 3. Internal and external housekeeping interfaces (CAN bus) 4. Interfaces to ISS (1553 and Ethernet) 5. Fast bus interface for event acquisition. The CPU is devoted to the control of the apparatus and the general optimization of the performance of the instrument in terms of data budget and detector status. It is expected to function autonomously and to reconfigure the working parameters with little or no intervention from the ground. It is capable of handling alarms and contingencies in real time minimizing possible damage to the instrument. Long term mission operation and observation planning will be implemented from the ground with specific telecommands used to overrule the specific operation parameters of the instrument. By sending immediate or time-delayed telecommands it will be possible to define the various operation parameters of the instrument in terms of specific physics objectives or specific situations.

The main CPU tasks are: 1) Power on/off of all subsystems. 2) Perform periodic calibrations. 3) Start acquisition / Run. 4) Define Trigger mode acquisition. 5) Read Housekeeping. 6) Take care of real time contingency planning. 7) Perform periodic Download / Downlink. 8) Handle (slow control) 1553 commands.

6.2 Housekeeping module

The housekeeping module is connected to the CPU with the task to distribute commands to the various detectors and to collect telemetry for them in order to monitor in real-time the status of the experiment and optimize its observational parameters.

There are two modules, one internal to the CPU (I-HK), devoted to monitor critical systems, power on/off of secondary power supply etc. I-HK is turned on together with the CPU and enables power on to all subsystems. The ex-

ternal housekeeping board (E-HK) is devoted to the general slow control and monitoring of the status of the apparatus.

I-HK functional module capable of handling both single (upon request) or cyclic (periodic) acquisition/commanding operating both is possible according to the acquisition program and status. Different acquisitions and controls are foreseen. For instance all relays to switch on/off secondary power supplies and subsystems are controlled by High Level signals. This approach has the advantage of a great degree of flexibility keeping at the same time a strong robustness and reliability.

Some of the main electrical interfaces monitored by the module are: 1. Voltage monitor (Primary $-120\text{ V } 28\text{ V}$; Secondary: $+ - 5\text{ V } +12\text{ V}$, $+3.3\text{ V } -700\text{ V}$) 2. Current monitor 3. Temperature monitor 4. Contact closure (Lid status, relays) 5. Digital communication protocol.

6.3 Communication protocol

Communication between different layers of the data acquisition chain operate with LVDS (differential signal) to minimize interference and reduce power consumption. All lines are redundant, with each line employing double connectors at each end to increase reliability of the system and resistance to vibrations and thermal stresses. High level communication protocol between CCB and CPU is based on a simplified version of the SpaceWire.

6.4 Commands from the ground

Slow control communication from/to ground is based on the MIL-STD-1553B standard. 1553 is a slow speed (1 Mbit/s) bus used in space and aeronautics for transmission / reception of critical information. In JEM-EUSO the 1553 bus is employed to:

1. Switch on/off the instrument or part of its sections.
2. Issue telecommands from the ground.
3. Set general acquisition parameters based on detector status. Furthermore they can be used to patch (reprogram) part of the software at CPU, DSP or FPGA levels and dump the memory of each level in case of debugging.
4. Reception of keep-alive information from the detector, of nominal events, alarms.
5. Switch from main to spare channel (acquisition, power supply, etc.).

6.5 Storage, downlink, download

Data stored in the mass memory of JEM-EUSO are periodically sent to ISS via a high speed link based on Ethernet protocol. Data are subsequently downlinked to the ground

via TDRSS satellite link or stored on hard disks. Data transmitted to the ground consists of: 1. Cosmic ray data from the focal surface 2. Atmospheric Luminous Phenomena, lightning etc. 3. Housekeeping information 4. Alarm 5. Calibration data 6. Ancillary information.

Data are sent to the ground with highest priority given to housekeeping and alarm information. Experimental data are sent to ground with main priority to high energy particle data and special trigger (e.g. Transient Luminous Phenomena, meteoroids, lightning, etc.). The amount of data downlinked to the Earth is $\simeq 3\text{ Gbyte/day}$, amounting to about 20% of the data budget. The rest of the data is stored on board ISS on a dedicated disk server. Disks are then periodically returned to the ground with Soyuz capsules. In the current configuration, it is expected to have $\simeq 5\text{ TByte/6 months}$ sent on the ground. Even though the UHECR event rate is very low, the background occupies a large part of the data. This is especially true at low energies, where shower development is shorter and more difficult to sort with on board algorithms. A higher memory capability allows to increase the trigger efficiency at low energies (around) $3 - 4 \cdot 10^{19}\text{ eV}$ and improve the data bandwidth devoted to atmospheric physics (IR and UV channels).

Acknowledgements. This paper is dedicated to the memory of Y. Takahashi.

This work has been partially supported by the Italian Ministry of Foreign Affairs, General Direction for the Cultural Promotion and Cooperation.

Edited by: K.-H. Kampert

Reviewed by: two anonymous referees

References

- Casolino, M.: The data acquisition and handling system of JEM-EUSO experiment, *Nucl. Instrum. Meth. Phys. Res. A*, 623, 516–518, doi:10.1016/j.nima.2010.03.055, 2010.
- Casolino, M., Altamura, F., Basili, A., et al.: The PAMELA storage and control unit, *Adv. Space Res.*, 37, 1857–1861, doi:10.1016/j.asr.2005.06.012, 2006.
- Ebisuzaki, T., Uehara, Y., Ohmori, H., et al.: The JEM-EUSO Project: Observing Extremely High Energy Cosmic Rays and Neutrinos from the International Space Station, *Nuclear Physics B - Proc. Suppl.*, 175–176, 237–240, doi:10.1016/j.nuclphysbps.2007.11.005, 2008.
- Kajino, F.: The JEM-EUSO mission to explore the extreme Universe, *Nucl. Instr. Meth. Phys. Res. Sect. A*, 623, 422 – 424, doi:10.1016/j.nima.2010.03.023, 2010.
- Santangelo, A., Bittermann, K., Mernik, T., and Fenu, F.: Space based studies of UHE neutrinos, *Progr. Part. Nucl. Phys.*, 64, 366–370, doi:10.1016/j.pnpnp.2009.12.050, 2010.
- Takahashi, Y. and the JEM-EUSO Collaboration: The JEM-EUSO mission, *New J. Phys.*, 11, 065009, doi:10.1088/1367-2630/11/6/065009, 2009.