

ISTITUTO NAZIONALE DI FISICA NUCLEARE

Sezione di Milano

IT8900295

INFN/BE-89/1

9 Gennaio 1989

P. Guazzoni, G. Taiocchi, L. Zetta:

A STRETCHER AND HOLDER MODULE

A Stretcher and Holder Module

Paolo Guazzoni^(a), Gianfranco Taiocchi^(b), Luisa Zetta^(a)

(a) Istituto Nazionale di Fisica Nucleare - Sezione di Milano and
Dipartimento di Fisica dell'Università - via Celoria 16 - 20133
Milano - Italy

(b) Ditta Takes - Ponteranica Bergamo - Italy

ABSTRACT

This paper describes the general structure and the performance of a compact module, designed to stretch and hold analog signals up to several hundreds of microseconds, without remarkable changes in the pulse height and shape, and to provide a convenient interface between detector systems and data acquisition equipments.

1.- INTRODUCTION

The STretcher and HOLDER Module (STHOM), described in the present paper, is a modular nuclear instrument that will interface a quantity of different detector chains into a single data acquisition system, or will be used in a multiparametric apparatus also to reduce the number of ADC's needed.

In fact, to collect energy spectra of ions identified in mass and charge by means of the online computation of ion identification functions ⁽¹⁾ or of the handling of the different physical quantities involved in the Bragg curve spectroscopy method ⁽²⁾, or in general to measure several parameters in nuclear reaction experiments, different analog systems are interfaced to a quite complex data accumulation equipment. In this case the timing adjustment may present a number of difficulties, mainly because of the great quantity of adjustable delays to be used. This was the reason that led us to design, build and test STHOM, a module able to stretch and hold the signal of up to four different parameters from up to four different detector systems.

2.- GENERAL DESCRIPTION

STHOM is built in single-width NIM module. All the input and output analog signal connections are included in the front panel (fig.1), together with the toggle switches for the Rise Time Protection changing (2,4,8, μ s) and the subgroup selection. The binary-coded, logic channel identification output, the general gate input and the ADC's timing controls are on the rear panel. The working mode of the present module can be understood in accordance with fig.2., in which STHOM is represented by means of a symbolic and simplified diagram. The vertical planes represent the stretcher and holder sections for each detector system, while at the end, the horizontal ones can be considered as the output sections. Indeed, using a hypothetical matrix representation, it may be said that

the signals from the detector systems enter the module by columns and exit by rows.

STHOM consists of four units, each concerning just one detector and its four parameters and made of four linear gates (LG), four stretchers and holders. These units are completely independent from each others, with regard to the analog input signals. The output signals are multiplexed into four buffers, corresponding to the four different parameters of each detector system and to the four ADC's inputs.

Regarding the handshake with the ADC's, the logical signals used for STHOM consist in two different types: timing of the ADC (dead time, rise time protection, data transfer flag) and for partition of the acquisition system memory. In fact the subgroup selection is made by means of the word bit not used for the data, to obtain a correct labelling of different subgroups. It is necessary, anyway, to decide, a priori, the number of bits reserved to the label. This requirement is satisfied through the Subgroup switch, that suitably chooses and transfers the label bits, via the rear connector, in accordance with the Data Transfer level.

The STHOM timing diagram is presented in fig. 3, while fig. 4 shows the schematic of one unit.

The arrival of one input strobe pulse (STROBE) from the coincidence of the detector chains is assumed as zero time for the signal processing. Moreover, STROBE supplies the storing command: in fact, it is used as trigger pulse for the rise time protection (RTP). The trailing edge of RTP enables the holder flip-flop (HOLD).

The capacitors of the stretcher circuits (STRET), normally left discharged, are charged only during the RTP and HOLD time.

The system is also provided of an only input gate to inhibit HOLD, the same for all the parameters and detectors. It can be used as RUN/STOP and also, for more sophisticated multiparametric systems, to allow the acquisition of one event at a time.

HOLD calls for the transfer logic circuit through the latch, the priority

encoder and the decoder.

In output the four stretchers of each of the four groups are connected by means of a CMOS switch. The sampling signal (SAMP) for the ADC's starts about $1 \mu\text{s}$ after the leading edge of the analog output. This time is necessary to have flat output levels. The height of the analog pulses was stable up to the end of last RTP from the ADC's, or, at least -in its absence- for the SAMP duration.

At the trailing edge of the last RTP from the ADC's, the monostable "out analog end" starts, and after, the interrogation begins of a new HOLD or, again, of one event of less priority, in the case of two or more coincident events.

The latch is introduced to avoid the possibility of a contemporary request of greater priority, or, otherwise, in the case of particularly complex set of events, to assure the transfer of all the involved parameters.

The analog switching happens as soon as the RTP's from the ADC's end.

Before a new SAMP starts, it is necessary that all the four dead times from ADC's are terminated, i.e. it starts after the end of the ADC's data transfer flag signal.

The use of the SAMP allows the choice of short RTP for the ADC (500 ns) and the full utilization of the converter velocity, because of the possibility to detect the input pulses when they are already flat. Moreover SAMP allows to commute the inputs as soon as the RTP ends -i.e. during the ADC dead time- and to start again, immediately, with a new conversion, as soon as the latter ends.

With a new strobe, the corresponding analog input is immediately buffered with the same time sequence and is held up to the end of the conversion made by the ADC on the previous pulse. In this way it is possible to use STROM also for coincident pulses, unlike customary mixers.

As previously said, each unit, consisting of linear gates, stretchers and holders, begins to operate at the arrival of the STROBE. In coincidence with its leading edge starts the RTP monostable, whose width (2,4,8 μs)

can be selected by means of the three position toggle switch in the front panel. Then the discharge circuit of the stretcher capacitor is open, so allowing its charge. At the end of the RTP starts the HOLD, which let the capacitor free to follow the input signal and, at the same time, closes the input LG to avoid pile-up.

Then, HOLD enables the priority encoder through the open latch. This encoder closes the CMOS corresponding to the input code (e.g. A1, or A2, or A3, or A4 corresponds to A, and B1, B2, B3, B4 to B, ... and so on) by means of a decoder.

When the CMOS is closed, the signal held high is brought out through the output buffer of the corresponding parameters (e.g. the A1 signal through the output buffer 1, A2 through 2, A3 through 3 and so on).

At the same time, the priority encoder enables the selection group, which by means of a 1 μ s delay gives in output the SAMP for the ADC. When the latter receives the SAMP, it answers with RTP and Dead Time signals. At the incoming of RTP the address of the memory partition of data acquisition system corresponding to the detector in process (e.g. A) is latched. The end of the longest RTP from the ADC's resets HOLD and allows it to present in output another signal. Otherwise the Dead Time forbids, for its full duration the new sampling, which starts again at the end of all the four Dead Time signals.

We have to signify that the Stretcher is made by an input amplifier and a diode used to charge the capacitor. The capacitor level has to follow the height of input pulse, because of the input amplifier feedback.

3.-TESTING

STHOM was tested with two different aims in view: firstly to control its performance, and, secondly, to check its behaviour in an experimental detections chain.

3.1) PERFORMANCE

3.1.a) Stability

A pulse of fixed amplitude (1.8V) approximately at half of the full dynamical range (4V), coming from a BNC-PB4 pulser entered the linear input of STHOM, while the trigger out was used for the STROBE. The STHOM output was sent to a SILENA CATO MCA, for a one week test. The result is a stability better than 1mV/day.

3.1.b) Holding

Fig.5 shows the simplified electronic chain for the Holding test. The trigger from the HP8012B pulse generator was used as main trigger, while that of BNC-PB4 pulser as STROBE for STHOM. The pulse out of PB4 was connected to one of the STHOM linear inputs. To verify the capability of STHOM to hold the pulse height for a long time, we used pulses, from the HP8012B, with low duty cycle to enter its Dead Time input.

In this way, it was possible to compare the height of the pulse immediately converted (Dead Time input disconnected) with that held for the chosen time. The obtained result is a decrement less than 45 $\mu\text{V}/\mu\text{s}$.

3.1.c) Integral and differential nonlinearity

A set of tests was made, with the DAG generator⁽³⁾ to determine the integral and differential linearity for the full dynamical range (0-4V), using 39 pulses, from 100 mV up to 3900 mV, step 100 mV. The results are: integral nonlinearity 0.0006%; differential nonlinearity 0.1%.

3.1.d) Resolution and gain

Using the PB4 pulser linear output and the trigger out for the strobe, the resolution obtained was 0.1%.

The gain was tested for the four parameters of each detector input. It was constant for all the channels within 0.2%.

Another test, concerning the gain, was made to investigate its dependence

from the RTP value. Also in this case the gain is constant within 0.04%.

3.2) EXPERIMENTAL RESULTS

The second kind of testing was addressed to verify STHOM behaviour in an electronic chain for the identification of charged particles emitted in nuclear reactions.

We used STHOM for the timing adjustment during the connection between MONDAN⁽⁴⁾, the data acquisition system of the Laboratori Nazionali del Sud - Catania (LNS) and an apparatus, previously realized and used⁽⁵⁾, able to identify light particles emitted in nuclear reactions. For the off beam test (see fig.6 for the electronic chain), the DAG pulser was employed. Fig. 7 shows the photo of the most significant pulses from the chain.

To use STHOM in an on beam experiment, the DAG pulses were substituted with the corresponding signals from a detector telescope. An identified energy spectrum from the $^{12}\text{C}(^7\text{Li}, t)^{16}\text{O}$ reaction⁽⁶⁾, collected at 20° -laboratory angle-, 43.86 MeV - incident energy- at the SMP13 Tandem of LNS, is shown in fig.7.

At the end, we can conclude that STHOM is a very precise and useful instrument to be employed in electronic chains or multiparametric systems, whenever it is necessary to hold pulses for a very long time, without remarkable change in the pulse height.

ACKNOWLEDGMENTS

We wish to thank Mr. C. Cali, and Mr. F. Ferrera of the Laboratori Nazionali del Sud - Catania for kind cooperation during the connection of STHOM with Mondan.

This work was partially supported by a grant from the Italian Ministry of Education.

R E F E R E N C E S

- 1)- F.S. Goulding & B.G. Harvey
Ann. Rev. Nucl. Sci. 25(1975)167
- 2)- C.R. Gruhn, M. Binimi, R. Legrain, R. Loveman, W. Pang, M. Roach,
D.K. Scott, A. Shotter, T.J. Symons, J. Wouters, M. Zisman, R.
Devries, Y.C. Peng, W. Sondhein,
Nucl. Instr. and Meth. 196(1982)33
- 3)- P. Guazzoni, P. Michelato, G.F. Taiocchi, L. Zetta
Nucl. Instr. and Meth. 185(1981)219
- 4)- A. Anzalone, P. Finocchiaro, F. Giustolisi, D. Nicotra, G. Raciti,
G. Scollo and S. Urso
LXVIII Congresso Nazionale SIF - Perugia, October 1982
- 5)- P. Guazzoni, P. Michelato, G. F. Taiocchi, L. Zetta
Nucl. Instr. and Meth. 200(1982)323
- 6)- E. Fabrici, E. Gadioli, P. Guazzoni, M. Jaskola, L. Zetta
private communication

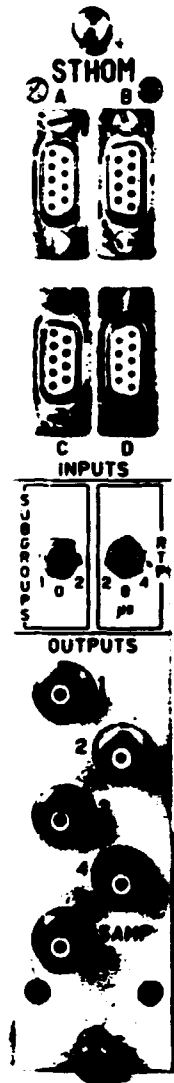

Fig. 1 - The front panel

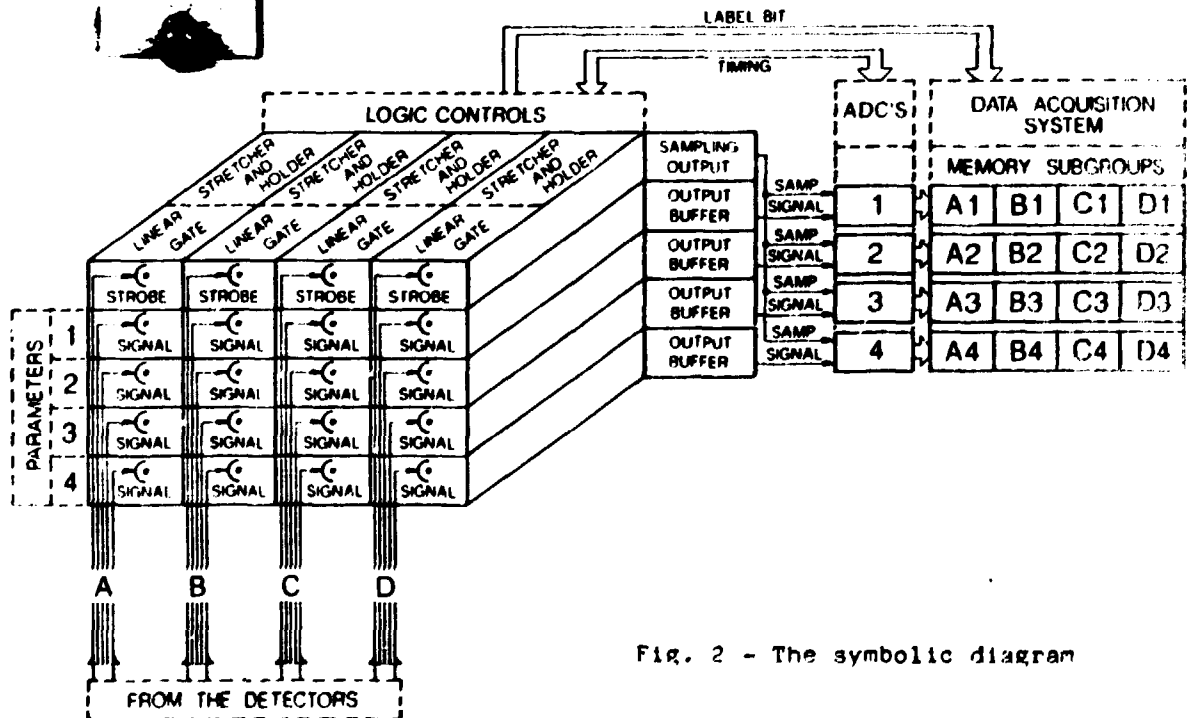

Fig. 2 - The symbolic diagram

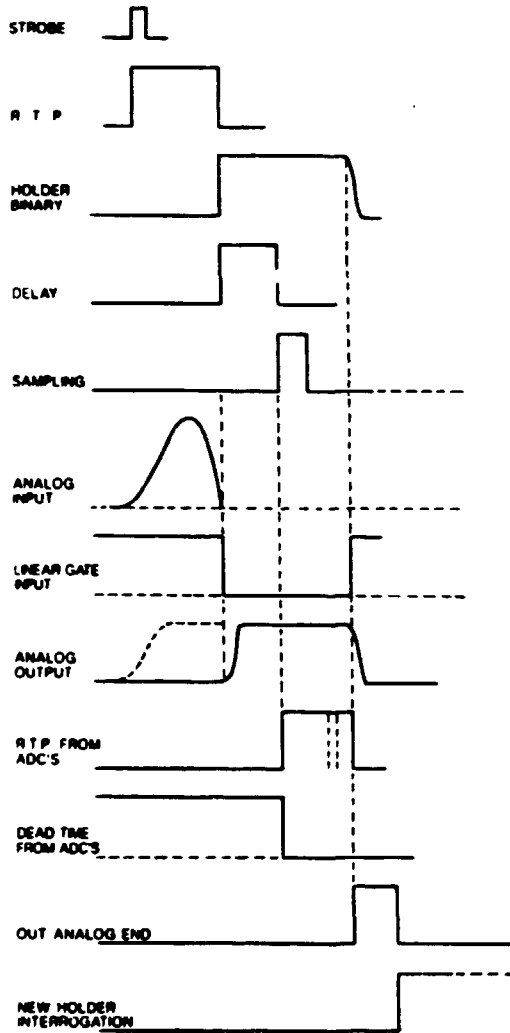

Fig. 3 - Timing diagram

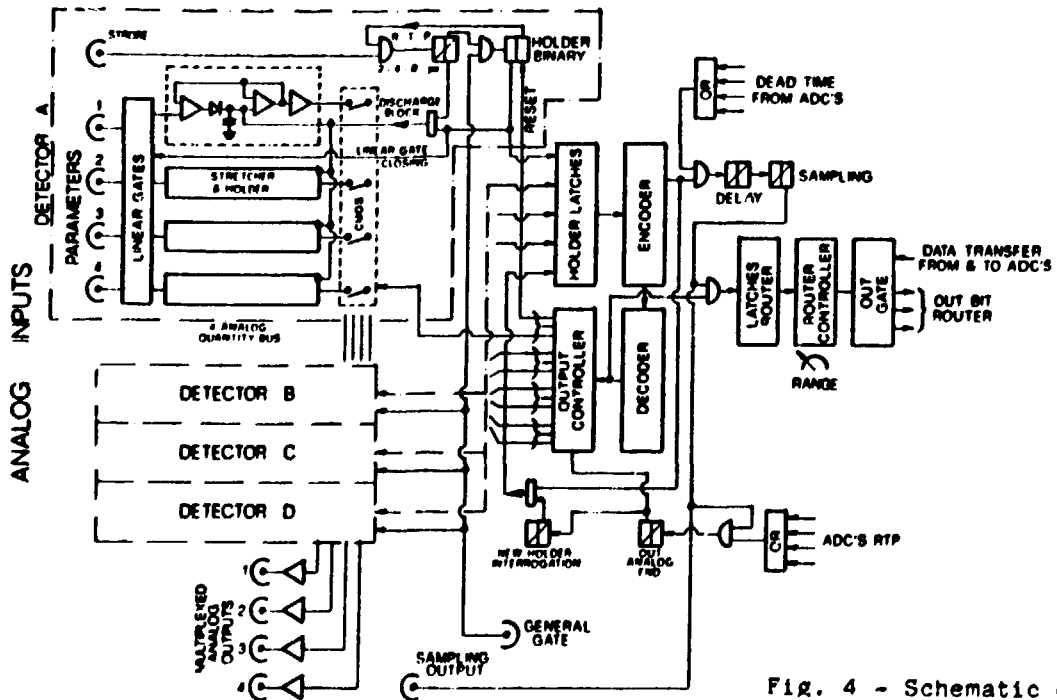

Fig. 4 - Schematic of one unit

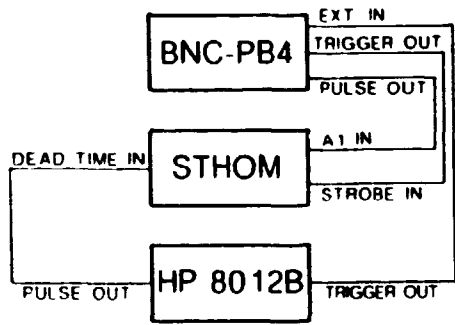

Fig. 5 - Simplified chain for holding test

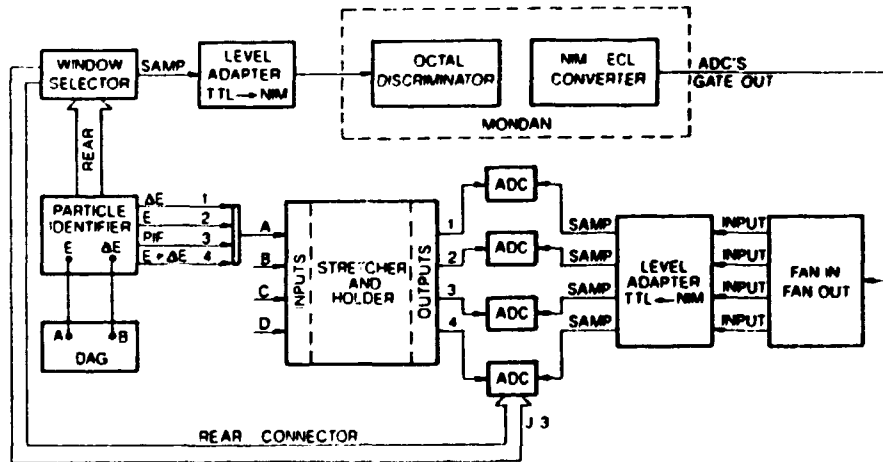

Fig. 6 - Simplified chain for identifier-Mondan connection (see text)

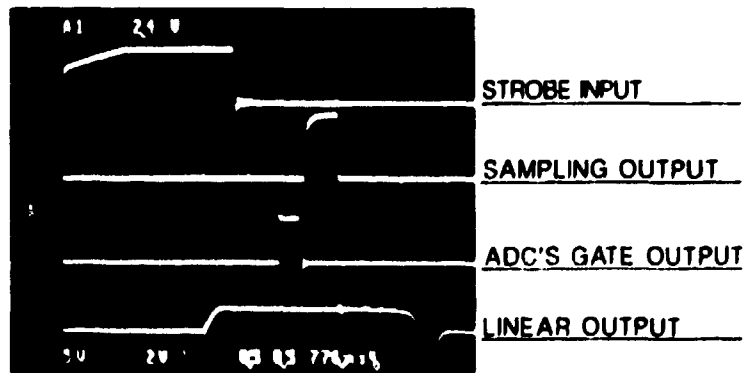

Fig. 7 - Photo of the timing of the 4 most significant pulses from the chain in fig. 6

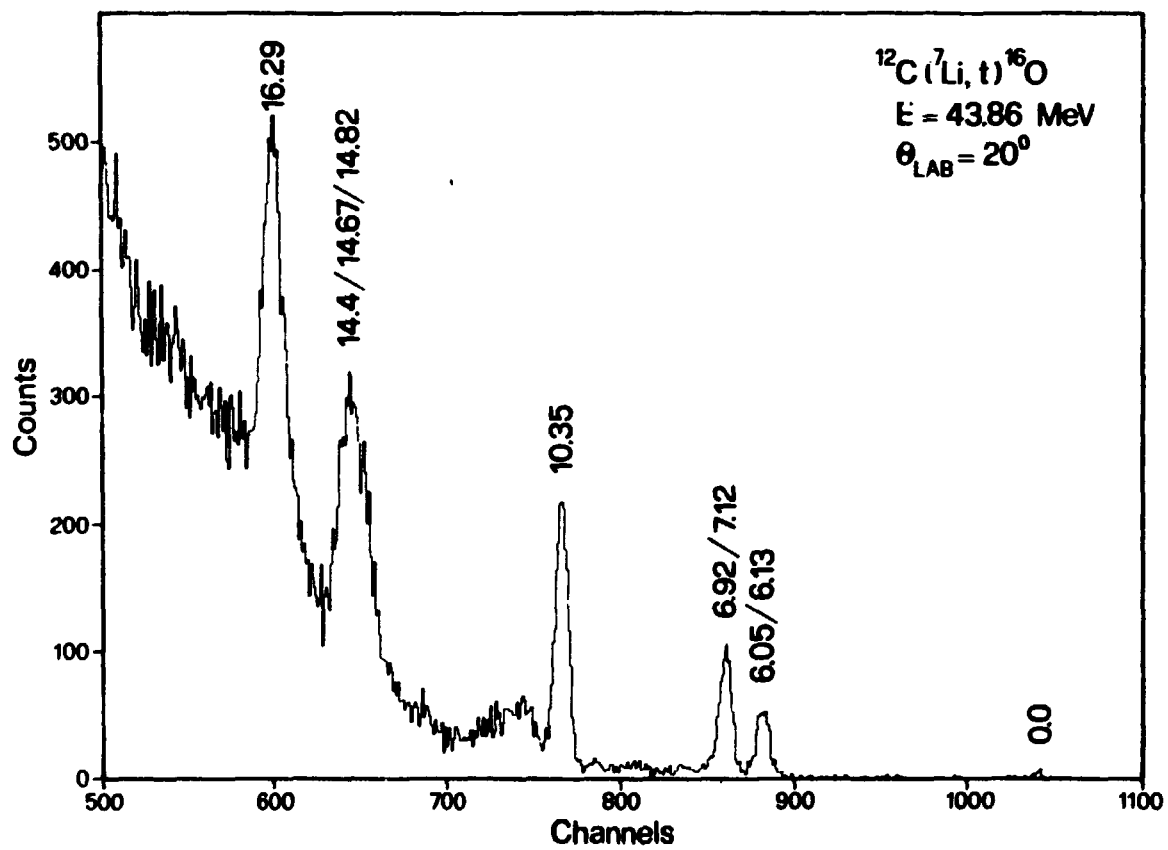

Fig. 8 - Spectrum of the triton emitted in the $^{12}\text{C}(^7\text{Li}, t)^{16}\text{O}$ reaction at 43.86 MeV incident energy (see text)



MICROCOPY RESOLUTION TEST CHART
NATIONAL BUREAU OF STANDARDS
STANDARD REFERENCE MATERIAL 1010a
(ANSI and ISO TEST CHART No. 2)