

FITFES: A Wearable Myoelectrically Controlled Functional Electrical Stimulator Designed Using a User-Centered Approach

Marco Crepaldi, *Member, IEEE*, Rune Thorsen, Johanna Jonsdottir, Silvia Scarpetta, Lorenzo De Michieli, Mirco Di Salvo, Giorgio Zini, Matteo Laffranchi and Maurizio Ferrarin, *Senior Member, IEEE*

Abstract—Myoelectrically Controlled Functional Electrical Stimulation (MeCFES) has proven to be a useful tool in the rehabilitation of the hemiplegic arm. This paper reports the steps involved in the development of a wearable MeCFES device (FITFES) through a user-centered design. We defined the minimal viable features and functionalities requirements for the device design from a questionnaire-based survey among physiotherapists with experience in functional electrical stimulation.

The result was a necklace layout that poses minimal hindrance to task-oriented movement therapy, the context in which it is aimed to be used. FITFES is battery-powered and embeds a standard low power Bluetooth module, enabling wireless control by using PC/Mobile devices vendor specific built-in libraries. It is designed to deliver a biphasic, charge-balanced stimulation current pulses of up to 113 mA with a maximum differential voltage of 300 V. The power consumption for typical clinical usage is 320 mW at 20mA stimulation current and of less than 10 μ W in sleep mode, thus ensuring an estimated full day of FITFES therapy on a battery charge.

We conclude that a multidisciplinary user-centered approach can be successfully applied to the design of a clinically and ergonomically viable prototype of a wearable myoelectrically controlled functional electrical stimulator to be used in rehabilitation.

Index Terms—Functional Electrical Stimulation, EMG, User-Centered Design, Rehabilitation, Stroke.

I. INTRODUCTION

WHEN muscle control is compromised as a consequence of a stroke, one of the main challenges for the clinician is to effectively rehabilitate the paretic muscles [1], [2]. Typically, the hand function is impaired by hyperactivity of the flexor muscles [3], resulting in a spastic closed hand posture [2], which leads to learned non-use of the hand [4], thus severely limiting the activities in daily living [5]. Recent advances in stroke rehabilitation have demonstrated that by providing information on muscle activation (proprioceptive feedback) during activities, paretic muscles can be re-educated as a result of motor plasticity [6]. In this context, the myoelectric signal generated from volitional muscle contraction can be used for

Thorsen, Jonsdottir and Ferrarin are with IRCCS Fondazione Don Carlo Gnocchi Onlus, Via Capecelatro 66, 20148, Milano, Italy.

Crepaldi, Di Salvo and Zini are with Istituto Italiano di Tecnologia, Electronic Design Laboratory (EDL), Via Enrico Melen 83, 16152, Genova, Italy.

De Michieli, Scarpetta and Laffranchi are with Istituto Italiano di Tecnologia, Rehab Technologies Lab, Via Morego 30, 16163, Genova, Italy.

Corresponding author: mferrarin@dongnocchi.it

such proprioceptive feedback (biofeedback) [7]–[9]. Even a paretic muscle (paralyzed but with a trace of volitional control) which cannot exhibit meaningful movement or counteract co-contraction, will emit a weak signal, i.e. the voluntary myoelectric signal, that can be used as a feedback [10].

Functional Electrical Stimulation – FES – has been clinically used for several decades for inducing muscle contraction of paretic muscles, as a therapy to reeducate neuromuscular control [11], and/or as an orthotic intervention to reinforce muscle contraction during movements [12]. Transcutaneous FES uses surface electrodes over the target muscle through which current impulses are delivered to the underlying tissue, generating action potentials in the motor nerves and, in turn, in the muscle fibers which again produces a functional movement [6], [7], [11]–[13]. By controlling the current intensity the resulting force can be modulated and is less susceptible to changes in electrode impedance than a voltage controlled stimulation. Due to the high skin impedance, typically a few k Ω , the stimulator needs to deliver high voltage pulses in order to let appropriate current flow through the tissues.

By combining the two mentioned methods, a specific technique known as myoelectrically controlled functional electrical stimulation (MeCFES) is obtained, which can provide multiple benefits. First, muscles with weak volitional contraction can be used to directly control stimulation of the same muscle (homologous stimulation) [14]. Moreover, the patient experiences an increased volitional movement range and force, gets sensory feedback proportional to the volitional effort and spasticity may be reduced by the stimulation [15]. For example, it has been demonstrated that applying MeCFES to

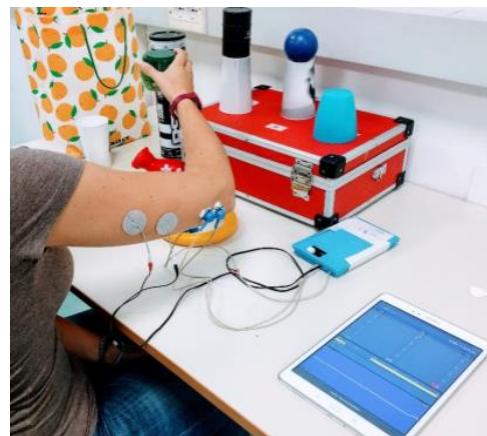

Fig. 1. Experimental version of a MeCFES setup. The stimulation device (blue box) is connected via 2 EMG electrodes (blue) over the distal part of the triceps muscle and two stimulation electrodes (gray) over the central part of the triceps. A further ground electrode is placed between the EMG electrodes to establish a reference potential. A tablet is used for the user feedback to show EMG signals and current level of stimulation intensity, which is proportional to the volitional muscle contraction level.

the finger extensors can help the patient open the hand and allow the physiotherapist to work with task-oriented therapy (TOT), which is one of the most promising rehabilitation strategies for stroke survivors [16]. In previous studies [6], [14], the MeCFES was applied using an ad-hoc developed prototype. Though portable, it was designed with functionality in mind. In the clinical testing it was placed on the table with wires connecting each electrode with the device. Like other experimental setups this is often leading to tangling and interfering with the movements involved in the exercises [16]–[18]. These exercises are part of TOT practice, in which the therapist guides the patient to perform purposeful movements, such as reaching, grasping and moving objects. These tasks are defined on an individual basis depending on the main functional limitations in reaching movements of the subject. Recording electrodes are placed over a ‘driving’ muscle for the reaching synergy task and stimulation electrodes are placed over the muscle(s) that needs to be activated in order to complete the task. For example, for patients with weak wrist/finger extensors where movement is possible but limited, both recording and stimulation electrodes are placed over the same extensor muscle in order to assist a functional movement. When the extensor muscle activation is too low to be read, the activation of the triceps or deltoid muscles (part of the movement synergy) can be recorded to drive stimulation to the wrist/finger extensors to open the hand for a successful reaching and subsequent grasping movement.

The training and device setup sometimes resulted in ergonomic problems as the device and TOT objects had to share a limited space in front of the patient (see Fig. 1) and long loose electrode wires were prone to tangling and breaking.

Functionally, the MeCFES proved to be an effective and clinically useful technique, [6], [14] therefore it was concluded that further effort should go into designing a more ergonomically and user-friendly device. Consequently, we decided to develop a new MeCFES device, the FITFES (Fondazione Don Gnocchi Istituto Italiano di Tecnologia Functional Electrical Stimulator) for use in clinical rehabilitation of stroke patients, applying a rigorous user-centered design approach.

With respect to standard EMG recording and FES devices alone, the MeCFES technology, which is based on the combination of the two, adds further requirements for the electronic circuitry, which have to be addressed for an effective EMG-driven stimulation. A first issue is that the stimulation current will generate a voltage which is about six orders of magnitude larger than the recorded EMG signal. In fact, depending on the muscle type and size, a current of several tens of mA (up to 100mA for large lower limb muscles) may be required and, considering that the electrode impedance is around or above 1 k Ω [19], the correspondent voltage applied to the stimulation electrodes may be above 100 V. This gives rise to significant stimulation artefacts in the signal recorded by the nearby EMG electrodes [20], since they should pick up myoelectric activity which is in the order of 100 μ V [10]. A second problem is that electrolyte-skin interface adds a half-cell potential that will depend upon the ion concentration [21]. This is typically filtered by high pass filtering, but after the

stimulation pulse is delivered the residual charge on any recording electrodes must be very low to prevent saturation of the input amplifier. Therefore, biphasic pulse trains as shown in Fig. 2 (a) are used: they are able to reduce both the stimulation artefacts and the risk of electrochemical skin damage. Moreover, it was empirically found that they are a good compromise between reducing discomfort and maximizing muscle recruitment [20], [22].

The FITFES electronics will therefore be optimized to generate a charge balanced stimulation doublet, minimize residual charge on the recording electrodes and limit parasitic currents (leakage currents) from the stimulator output to ground. These measures jointly minimize generation of stimulation artefacts in the recorded signal.

Apart from drop foot stimulators [12], FES devices for treating the upper extremity are not specifically designed for wearability (e.g., Biomation, Though Tech. Ltd, Curatronic, MyndTech), therefore a new concept has to be developed through studying design requirements. According to this significant wearability awareness, we hence involved the professional end-users, i.e., physiotherapists, in the FITFES development process, which was carried out by engineers and industrial designers in tight cooperation. Particularly, this process was composed of the following phases: assessment of

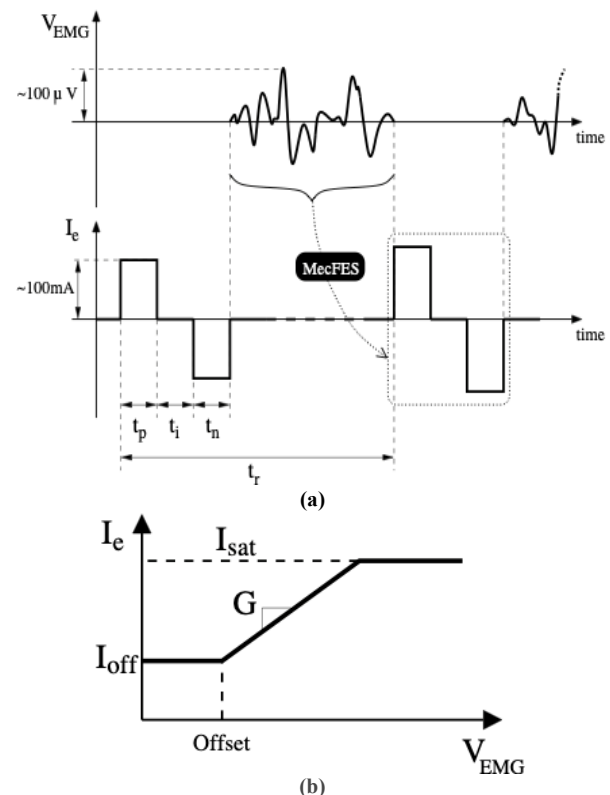

Fig. 2. (a) Illustration of the signals involved in MeCFES. Upper trace: the myoelectric signal (V_{EMG}) containing action potentials arising from volitional contraction of the muscle. The voltage artefacts resulting from stimulation pulses, which would saturate the EMG signal, are blanked out making the EMG signal visible in the window between two subsequent stimulation pulses. Lower trace: the biphasic stimulation pulse train with a controlled amplitude (I_e), having a positive phase (t_p), an intra-pulse interval (t_i) and a negative phase (t_n). They have a repetition interval (t_r). (b) the relation between EMG level and the stimulation current. Such relation is defined by a gain G , a saturation current I_{sat} and an offset current I_{off} (see section Measurements, sub-section Methods).

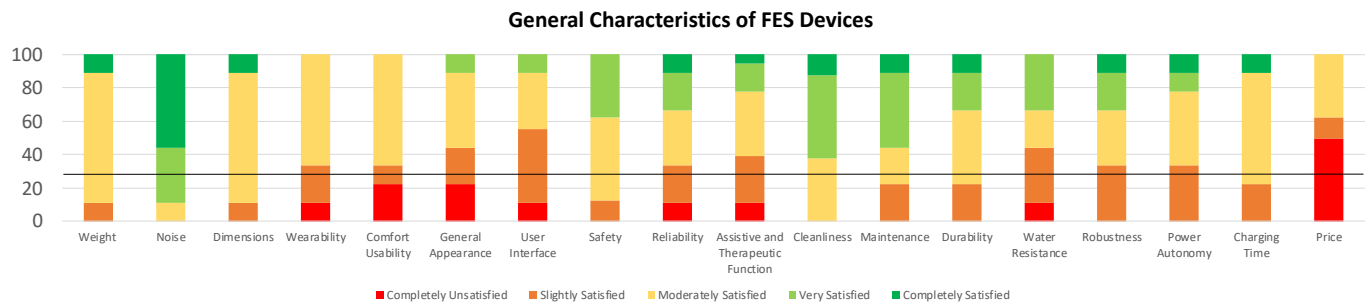

Fig. 3. Satisfaction level of the respondents on different aspects of existing FES devices. The solid black line indicates the 30% threshold as defined in A. Methods.

users' needs, analysis of the results, extraction of the design requirements, development of the final solution and evaluation of its performance. In the following sections, the methods and the results are reported for each phase. The focus of this paper is on the development aspects of the FITFES, therefore more clinical aspects (e.g. electrodes' placement, patients' opinion on FITFES performances etc.) will be considered in future works.

II. ASSESSMENT OF USER NEEDS

A. Methods

To define the functional requirements of the FITFES device, necessary to derive the specific ergonomic and electronic design requirements, we developed an ad hoc questionnaire to identify critical points of FES devices from the therapist point of view. It was submitted to 10 physiotherapists enrolled from our rehabilitation institute, to obtain data about users' priorities. The questionnaire consisted of two sections: 1) the therapist's viewpoint regarding strengths and weaknesses of FES devices; 2) the perception of patients' requirements. A 1 to 5 points Likert scale was used, naming the responses from "completely unsatisfied" to "completely satisfied" for section 3) and "almost always" to "never" for section 4).

To select key aspects to be improved and, consequently, determine the main areas where design efforts should be concentrated, we identified the items of section 1 (physiotherapist's viewpoint on FES devices) that received "slightly satisfied" or "completely unsatisfied" scores by more than 30% of respondents and the items of section 2 (patients' requirements about FES) that were scored "almost always" by more than 30% of respondents.

B. Results

The outcome of the survey is reported in Fig. 3 as a percentage of respondents scoring within the 5 categories of satisfaction. The most important issues, using the 30% threshold on the level of satisfaction, were: *Wearability*, *Comfort/Usability*, *General Appearance*, *User Interface*, *Reliability*, *Assistive and Therapeutic Functions*, *Water Resistance*, *Robustness*, and *Power Autonomy*. Based upon these results it was decided to address these issues first in the design of the device in addition to mechanical engineering, ergonomics and wearability aspects of the FITFES, including the positioning of the case on the body of the wearer.

As for the specific requirements for arm rehabilitation, the results are shown in Fig. 4 where the therapist's perception of their patients' requirements about a FES device is depicted.

From the patients' viewpoint, the most important FES device's features, exceeding the 30% of respondents' threshold, were easy usability, battery duration and safety.

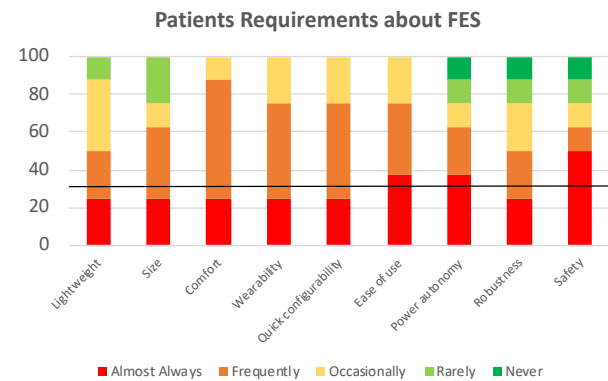

Fig. 4. Patient requirements about FES technology

We grouped two categories according to technical solutions required for their FITFES implementation. The first group gathers requirements that can be solved using electrical engineering, whereas the second group gathers all the requirements that can be solved with appropriate ergonomics and mechanical design.

III. DESIGN SPECIFICATIONS

The design specifications were derived from: (i) the feedback from previous studies (refer to Sec. I), (ii) the results of the ad hoc questionnaires reported in Sec. II and (iii) the intended use of the device, that is extensive use for upper limb rehabilitation in clinical environments. All these collected data were investigated by a multidisciplinary group composed of physiotherapists, biomedical engineers, electronic engineers and industrial designers, resulting in the identification of the main features the new FITFES device should address. Those characteristics were broken down into the following ergonomic and electronic design specifications of the device.

A. Ergonomics

The resultant design specifications on comfort, wearability and usability included the following points:

1. the device shall ensure tolerability and comfort, in both standing and sitting positions;
2. the device shall be equally applicable to either the right or the left upper limb;
3. the donning process shall be quick and intuitive;
4. the device shall have a stable fixation to the body, without risks of slipping during movements;
5. the device shall not interfere with upper limb movements;
6. the EMG and stimulation electrodes shall be positioned along the whole upper limb;

7. ease of access and command of the device by the physiotherapist shall be possible and guaranteed during use;
8. EMG and stimulation electrodes shall be those commercially available and easily replaceable;
9. the device shall provide visual feedback during operation;
10. the device shall have a general pleasant appearance.

These specifications were employed by engineers and industrial designers to draft a conceptual layout of the device, as reported in Sec. IV.

B. Electronics

The resultant design specifications included the following points:

1. the electronic system, with its internal high voltage components, shall match the designed case shape and size so as not to interfere with ergonomics constraints; the electronic components shall be chosen with cost and size awareness so that they can be soldered on a single PCB layer only.
2. the system shall include a wireless transceiver to enable connection to a generic control unit (smartphone, tablet or other consumer devices);
3. the system shall include a low-cost microcontroller to handle high voltage generation, stimulation settings, EMG signal processing and communication;
4. the system shall be capable of maintaining a separate power supply for the real-time clock (RTC) in the microcontroller to enable *Sleep Modes* and save settings data even when the device is turned off;
5. the system shall include a single multi-purpose button to enable quick activation/deactivation of the high voltage electronics, to forbid the user to change parameters. The settings should be set through a dedicated application which should be accessible by the therapist only;
6. the system shall be capable of consuming a maximum average current of 150 mA, including high voltage and low voltage subsystems;
7. the system shall be capable of 100 mA stimulation current with a voltage up to ± 150 V to handle impedance variations of the skin-electrode interface (a nominal 1 k Ω impedance corresponds to a voltage of ± 100 V) and for potential use also in lower-limbs through a revisiting of the case;
8. the system shall be battery-powered using low-cost replaceable batteries commercially available;
9. the system shall be capable of running firmware updates, over the air, or wired to enable additional features;
10. the system shall include, for future use, an Inertial Measurement Unit (IMU); it can be used to extract kinematic data and understand when the device is in use with the patient or not, therefore sending it to *Sleep Mode*;
11. the internal architecture of the system shall be capable of modular channel extension, therefore adding EMG and stimulation channels possibly using the same low-level system partitioning.

Our rehabilitation application domain requires a water International Protection (IP) of 1 (dripping water) and the adherence to this constraint can be easily achieved by adopting

several sealing solutions (e.g., silicone foam or rubber or by using gaskets for moving parts). Considering such protection-level, a smooth form (refer to ergonomics design specification 10) helps water to slip away from the device. Sealing, given water resistance awareness in the design process, can be executed once the ergonomic solution is developed without impacting on functionality and related design choices. The production of custom gaskets, indeed, can be easily done with mechanical moulds, that typically are prepared when mass production is started. We have taken price into account during the successive design phase, e.g., for the selection of the electronic components, however, the final value depends on the target market, on profit margins and the production volume. For instance, by considering an investment to prepare an injection moulding for the complete ergonomic solution mass production (or vacuum moulding for the non-rigid parts) for the complete ergonomic solution, the cost of the enclosure can be significantly reduced to about ten Euro.

IV. DESIGN RESULTS

Taking into consideration the design requirements obtained for both ergonomics and electronics, and the intended use of the device, the layout of the new FITFES was drafted.

A. Ergonomics

Using both male and female anthropometric tables, we identified the magnitude and variability of anatomic variations for the design. These were used to define (i) feasible desired sizes for the different subsystems and (ii) required cable lengths in a preliminary design analysis phase. This preliminary phase further entailed analysis of joint physiology and kinematics of the upper arm, which defined boundaries on the range of motion, in three-dimensional space, of all the possible movements.

At the same time, the following solutions were considered to address requirements #7, #8, #9: the command centre should have three buttons and five LEDs easily accessible and visible (#7, #9), disposable EMG and FES electrodes were chosen (#8).

After having carefully considered the above points, we defined a number of possible device concepts, which were then assessed directly with physiotherapists using mock-ups that were fabricated for the purpose. Among the several concept solutions that were generated, a necklace layout-based solution was chosen for this application. We present here an analysis of the compliance of the “necklace layout” with respect to the requirements defined in the previous section to explain the advantages offered by this layout.

Fig. 5 shows a 3D rendering of the selected FITFES necklace layout. This layout provides several advantages compared to currently existing solutions [23]-[27]. First, the necklace layout ensured intuitive and ease of donning “by design” (#3), while the chosen rounded and smooth shape maximized comfort and tolerability in any body position (#1, #10). The device was equipped with a simple rotary joint on its back, to allow proper cables orientation, which is additionally useful to deal with both left or right arm application (#2). Moreover, the realisation of two cable channels, one for each side of the necklace, was designed to avoid entanglement with external objects, facilitating wearability and general aesthetic appearance. The

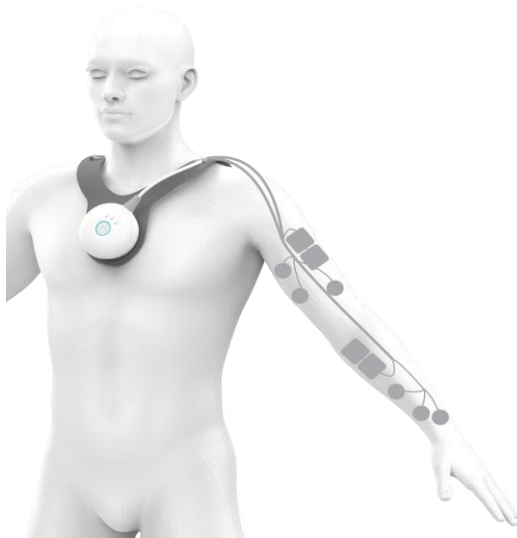

Fig. 5. Final FITFES necklace layout during normal use.

positioning around the neck ensured stability (#4) and freedom in the whole range of motion of the upper limb (#5). Furthermore, the adaptation of the device to different anthropometries was addressed by means of proper adjustment of the cable lengths (#6). The button to start and stop the device has been positioned at the center of the device for ease of localization (#7); in its close proximity, three coloured LEDs were positioned to ensure appropriate visual feedback (#9).

Commercial electrodes were chosen (FES: Axelgaard PALS, Fallbrook, USA; EMG: Blue sensor, MedicoTest A/S, Denmark), to guarantee ease of replacement (#8). Therefore, considering the compliance to the aforementioned requirements offered by the necklace layout, we decided to adopt this solution to proceed with the engineering development phase.

Fig. 6 (a) shows the 3D CAD of the full FITFES system, which includes the internal PCB and battery housing. Fig. 6 (b) shows the final device worn by a voluntary subject in “power on” state. Fig. 6 (c) shows an example of electrodes’ positioning during a possible session for treating a left hemiplegic hand. Please note that the physical connection to the electrodes is given preliminary here by using crocodile connectors for the test set-up. In the final production stage, cables with dedicated electrode connectors will be directly soldered onto the PCB.

B. Electronics

We focused on one channel stimulation device, controlled by two EMG channels as a minimal viable product to perform the first experiments.

The FITFES is a wearable device, which means the power has to be delivered from batteries. This determines the length of time the device can be used without having to replace or recharge the batteries. We considered the following three operation modes: *Sleep* (lowest power mode), *Idle* (EMG processing but no stimulation) and *Active* (EMG processing and stimulating). Based on the need of providing a “good power autonomy” from questionnaire (see Fig. 4) from the intended use of a full working day of rehabilitation, we established a worst case use time of the device of up to eight hours in *Active mode*. Assuming a typical 5400 mWh battery (i.e., 4.5V non-rechargeable AAA for a typical capacity of 1200mAh), the worst case of eight hours of *continuous* operation can be achieved with $1200\text{mAh}/8 = 150\text{mA}$ average current consumption of the device for stimulation. Though built-in batteries as Li-Po batteries are lightweight and present high yield, they have the disadvantages of requiring advanced monitoring and of excluding the use of the device while recharging. Therefore, we chose to use replaceable batteries in the standard range, namely triple A batteries which also come as rechargeable versions. In that way the therapist can have fresh batteries at hand for a quick replacement without experiencing downtime of the system. Further effort has been put into reducing the power consumption of the electronic circuits. It was decided to use 3 AAA batteries with a nominal voltage of least 1.2 V and 1200 mAh capacity equalling at least 4.3 Wh of energy at the disposal for the device before recharging or changing the batteries. This energy is still enough to provide eight hours up-time for the device as typically stimulation is not continuously kept active.

Fig. 7(a) shows a block scheme of the complete FITFES module. The design of the power electronics sub-system is crucial, because the stimulation, Bluetooth and control modules, together, can consume very diverse powers across the above operation conditions. Using three parallel buck-boost and linear regulators the battery voltage V_{BATT} can be fully utilized in the range 2.8 V – 5.5 V. The first Linear Regulator provides 1.8V supply to power the *Sleep Mode* circuitry [V_{RTC} in Fig. 7(a)]. Another buck-boost regulator generates the main 3.3V V_{MCU} voltage to power the circuits involved in *Idle* and *Active Modes*. Lastly, there is a dual output step-up converter for generating the ± 5 V voltage for EMG amplifier, stimulator modules and their supporting sub-circuits [V_{DD} and V_{EE} in Fig. 7(a)]. We included a specific sub-circuit, using a special discrete implementation, for high voltage (HVPS) supply generation for the stimulation output stage. The HVPS implements a FlyBack regulator in discontinuous conduction



Fig. 6. (a) 3D plot of the FITFES including internal electronics, (b) photograph of the final device, (c) an example of electrode placement of FITFES for treating a left hemiplegic hand: both EMG (circular shape) and stimulating (square shape) electrodes are on the wrist/finger extensor muscles.

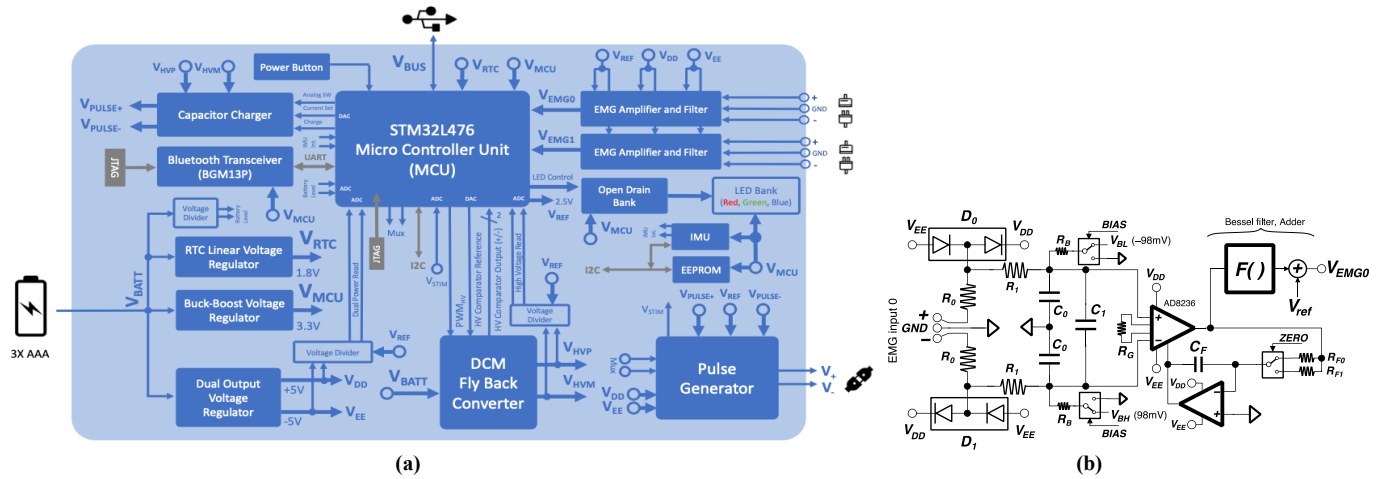

Fig. 7. (a) Block scheme of FITFES, with (b) simplified schematic of one EMG Amplifier and filter.

mode (DCM) to generate a high voltage overdrive (with $V_{HVP} = -V_{HVM}$) [28]. The voltage is digitally controlled to generate up to ± 150 V (300 V across V_{HVP} and V_{HVM}), used to power the special circuitry for the biphasic charge balanced current generator which will be described later. The core of the system is the STM32L476 Microcontroller, which features 1 Mb non-volatile memory for firmware and user data storage.

Consider that while the power regulation of V_{RTC} , V_{DD}/V_{EE} and V_{MCU} are demanded by commercial components that integrate output voltage control, in case of high voltage generation the MCU is responsible for output voltage control. The MCU indeed, uses a PWM_{HV} output directly triggered by an internal hardware timer on the MCU to implement the control algorithm, and reads both a differential comparator input connected to the primary circuit of the internal FlyBack transformer, and the generated output voltage. As high voltage can be dangerous in general, to provide a larger number of state variables for the control, the FlyBack sub-system comprises also a comparator reference input that is generated by the MCU using internal Digital-to-Analog Converters (DAC).

The system further comprises the Bluetooth transceiver, a LED bank used to indicate the status of the device, the IMU, the EMG amplification system and the EEPROM. Currently, the firmware can be upgraded via a USB connection. A further inertial sensor (IMU) is present and can be used, in future implementations, for monitoring movements. The system includes two input channels for measuring EMG, with specialized circuitry for stimulation artefact suppression and one charge balanced stimulation output channel.

As the system is designed to be compliant to medical devices regulations, LEDs with different colors (red, green, and blue) are provided to indicate the power-on/power-off button that is used to activate, pause or deactivate the device. All the remaining controls are posed using the dedicated Bluetooth channel. The BGM13P Bluetooth 5.0 module operates as a Generic Attribute Profile (GATT) server and implements read, write and notification mechanisms to a remote device. In particular, the server implements a TTY service with two characteristics (one in read-notify and another in write mode), and another service for EMG with a single read and notify characteristics. The remote device can send commands to the device using the TTY service and read EMG data using the other service.

To generate bi-phasic stimulation the FITFES comprises two dedicated sub-systems designated as Capacitor Charger and

Pulse Generator. The latter generates a current controlled pulse using the circuit fully described in [29]. The Capacitor Charger, which is controlled by the MCU, charges two electrolytic capacitors with the necessary charge to pose a predetermined current across the electrode load. The Pulse Generator considers the charge across these capacitors (V_{PULSE+} and V_{PULSE-}) to generate both positive and negative pulses. All the control signals to these sub-systems are managed by the MCU.

Fig. 7(b) shows the simplified schematic of the EMG Amplifier and filter stage. Both positive and negative terminals are connected through two 100 k Ω resistors (R_0) to two diode bridges (D_0 and D_1) to clamp under- and over-voltages that may result from stimulation. After a first low-pass filter stage ($R_1 = 100$ k Ω , $C_0 = 10$ pF and $C_1 = 100$ pF), the signal is amplified using an AD8326 instrumentation amplifier with 20 k Ω gain resistor R_g . The front-end injects a small offset current through V_{BL} and V_{BH} (obtained through a voltage divider, not shown) to help the system to recover after a stimulation pulse, thus not leaving the internal nodes at very high impedance. In our implementation the signal BIAS keeps always active the current injection. Common mode feedback is achieved by considering the output of the AD8326 and implementing an integrator feedback for 100 nF C_f on the reference pin of the amplifier. Signal ZERO is used to help the instrumentation amplifier with feedback network to recover after saturation caused by the injection of the stimulation pulse on the body. In particular, ZERO is activated during stimulation and released immediately before EMG signal acquisition. R_{F0} and R_{F1} are 1 M Ω and 1 k Ω , respectively. The complete front-end is powered by dual supply voltage V_{DD}/V_{EE} and has a 1.59 Hz–15.9 kHz bandwidth and 28.3 dB gain. The AD8326 output is then sent to a Bessel filtering stage $[F()]$, 3rd order, 500 Hz center frequency], and an adder stage to shift the signal voltage range to 0 V– V_{ref} for digital conversion.

Fig. 8 shows a photograph of the prototyped PCB that includes two EMG channels and one stimulation channel. Particularly careful placement is required for the high voltage capacitors that occupy a considerable height. The battery pack is placed at the bottom of the PCB, while at the top the central button is directly connected to the button and the RGB LED light is guided externally using custom plastic waveguides. As shown in this photo, the mechanical constraints led to the placement of the components following the circular layout of the device, which is different from standard laboratory and

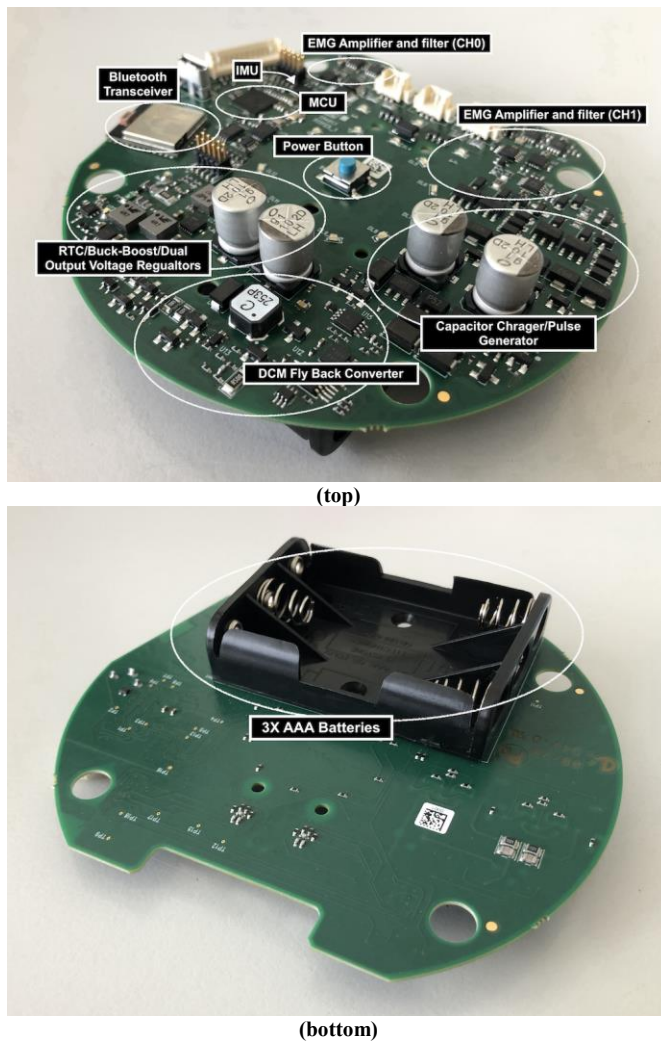

Fig. 8. Photograph of the prototyped printed circuit board, routed to match the mechanical enclosure specifically designed for FITFES, with details on schematic sub-systems placement.

rapid prototyping solutions in which a simple rectangular alignment is typically required. Here, the mechanical constraints, fundamental for usability, enforce a specific routing on the PCB.

V. MEASUREMENTS

A. Methods

We used two experimental setups to demonstrate the basic operation of FITFES. The first is implemented on a laboratory table and comprises the device powered using the AAA batteries and connected to the PC using the USB port, a Tektronix MSO6012A mixed signal oscilloscope and a charge balancing test circuit implemented with discrete components. Commands are transmitted to the device using a dedicated software. The second, comprises the device connected to the subject to demonstrate the operation of the FES algorithm with wireless communication and data download. The stimulation and EMG electrodes are positioned according to Fig. 6(c).

As previously argued in the introduction, a number of properties of the stimulation pulse will influence the quality of the measured EMG signal. Ideally the output should be perfectly charge balanced which implies a perfect control of

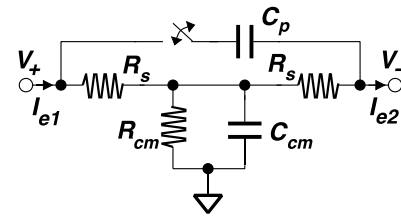

Fig. 9. Electrode equivalent RC-network for testing the common mode charge output of the stimulator. The total load resistance is set to $R_e = 1 \text{ k}\Omega$, $C_{cm} = 100 \text{ nF}$ and $R_{ref} = 100 \text{ k}\Omega$. The latter resistor is necessary to provide a well-defined reference for the oscilloscope when measuring on the floating output.

the pulse shape. We chose that the amplifier should be in *Active Mode* after 20 ms. Charge balancing was measured using the electrodes equivalent circuit model reported in Fig. 9 [21]. A common equivalent diagram of the electrode impedance is a series resistance representing bulk tissue and an electrode/skin interface capacitance (C_p) in parallel with a leakage resistance (R_{cm}).

Slew rate as the rise time from 10 % to 90 % of the final output current was measured using a purely resistive $1 \text{ k}\Omega$ load. As the device was supposed to be used for at least a full working day, we defined three different modes of device state: *Sleep*, *Idle* and *Active*. *Sleep* is the system in pause without EMG registration and transmission to the client unit. In *Idle Mode* EMG is recorded and displayed on the client unit and finally in full output we have chosen 20 mA, 50 mA and 100mA currents as representative to cover a typical stimulation regime [22].

The principal steps of the signal processing were done in the digital time domain. Removal of DC component using a numerical High Pass Filter (HPF), in the form $V_{filtered}[n] = \alpha (V_{filtered}[n-1] + V[n] - V[n-1])$, where $\alpha = 0.8$ (corresponding to a cut-off frequency of 70 Hz), $V_{filtered}$ is the filtered EMG signal and V is the input EMG signal. This filter is followed by a first order FIR comb-filter with notches at multiples of 16.6 Hz., this will have the additional advantage for reducing possible artefacts from the power supply network (50 Hz) and the stimulation itself (16.6 Hz). A blanking of the first 20 ms of samples after each stimulation pulse is applied followed by calculation of the RMS value of the remaining samples before the next pulse. This RMS value is fed to a piecewise linear function providing stimulation level. A detailed description can be found in [20]. In our implementation, blanking and repetition frequency can be adjusted based on specific Bluetooth commands.

The relationship between EMG signal power and stimulation current I (MeCFES algorithm) is taken from successful previous studies in [20], that in particular, it compactly expresses the equation $I = GV_{EMG,RMS} - I_{off}$, (which yields I only for values larger than 0) further saturated at I_{sat} , i.e., $I = I_{sat}$ if $I > I_{sat}$, where $V_{EMG,RMS}$ is the RMS value over a period of time (preceding stimulation), at the end of the previously introduced filtering chain.

The complete electronic system has been manufactured in a standard FR4 substrate and the mechanical enclosure and the necklace have been rapid-prototyped using a 3D printer and commercially available fabric, respectively.

B. Results

The measured weight of the device without batteries is 125 g (159 g with batteries), including enclosure and prototype

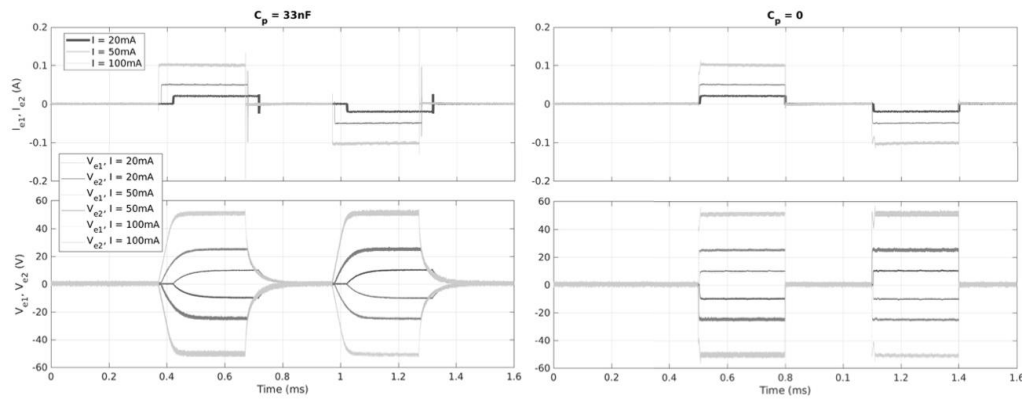

Fig. 10. Currents and voltages of the test circuit given in Fig. 9 at 3 different stimulation levels: 20 mA, 50 mA and 100 mA output, across a pure resistive 1 k Ω load for 33nF and 0 C_p . The lower traces show the voltage at the terminals and the common mode voltage.

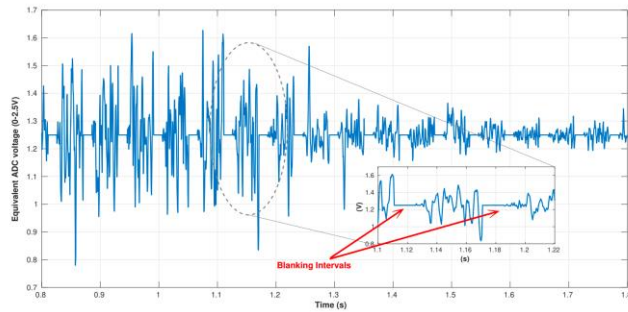

Fig. 11. The EMG from muscle contracted at maximum voluntary contraction during the first 300 ms, whereafter the muscle is relaxed.

cables. The weight of the necklace is 59 g, while the naked PCB weights 30 g. Overall, the patient has to carry a weight of 218 g during normal operation, which was assessed to be acceptable even for long therapy sessions. The main unit has been sintered using a Polyamide 12 material (Nylon 12), while the flexible necklace was prototyped in faux leather with silver finishing. The inner part of the necklace was prototyped in micro-perforated fabric, the same material used for the production of the part in contact with the body of backpacks.

Fig. 10 shows the measurement results obtained with the validation circuit of Fig. 9. Load-midpoint voltage was measured at both 100 k Ω and 100 k Ω ||100 nF midpoint to ground impedance. Hence the leakage current from the stimulator output to ground is less than 1 mV/100 k Ω = 0.01 μ A. The slew-rate (10-90 %) was measured at maximum stimulation. The performance of the stimulation circuit was evaluated by applying a stimulation pulse having a biphasic charge balanced waveform shown in Fig. 2, where $t_p = t_i = t_n = 0.3$ ms and $t_r = 60$ ms. It can be observed that the requirements of timing, stability and shape are met at both capacitive and resistive loads. At maximum stimulation level (113 mA), not shown here for the sake of brevity, the measured slew rate was 125 A/ μ s.

Power consumption was measured at three different modes of operation, *Sleep Mode*, *Idle* and *Active*, for 6.9 μ W, 185 mW and 320 mW at $I_{out} = 20$ mA. Observe that during *Sleep Mode* the system is powered on only for the internal Real Time Clock and it accepts external button power on events to possibly restore previous settings from the preceding session. During *Idle*, the system accepts Bluetooth commands, and the microcontroller is active, but the high voltage sub-system is switched off. During *Active* state, all the circuits are active.

Fig. 11 shows an EMG from a healthy muscle recorded during stimulation. First the subject contracted the muscle for

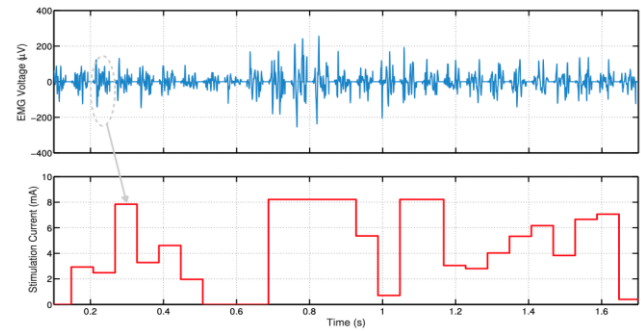

Fig. 12. FITFES real-time stimulation with real EMG data.

300 ms followed by relaxation. Observe that the first 20 ms of each 60 ms stimulation epoch is zeroed out. After that, there is a clearly identifiable volitional EMG with a peak amplitude around 0.8V (after ADC quantization and numeric amplification). In the relaxing phase, noise can be identified as a stochastic signal.

Fig. 12 shows a qualitative test of myoelectrically controlled functional electrical stimulation using the FITFES prototype, with saturation current I_{sat} set to 8.21 mA, $I_{off} = 0$ and $G = 1.79$ V/A. The actual EMG amplitude is calculated by the device and at the next cycle a stimulation current of the given peak-to-peak amplitude, that follows the MecFES algorithm, is delivered to the stimulation electrodes.

VI. DISCUSSION

The present study aimed to develop a wearable Myoelectrically Controlled FES device (FITFES) through a user-centered design approach. For this reason, the design requirements were set based on the results of a survey administered to physiotherapists with experience in the use of FES. In spite of the limited sample size of the survey, the results gave an indication of the key expectations of end-users for next generation FES devices, which in turn guided the definition of specific ergonomic and electronic design requirements.

This design approach enabled the implementation of a functional electrical stimulator with very interesting features compared to state-of-the-art devices. While many available FES devices still feature “benchtop” layouts, which limit the range of possible rehabilitation use-cases, the present FITFES device was conceived with an innovative necklace design. This feature makes it completely portable and steadily fixed on the body, ensuring a distributed grip around the shoulders and the chest of the patients, hence enabling the opening of new

TABLE I. COMPARISON WITH STATE-OF-THE-ART FUNCTIONAL ELECTRICAL STIMULATORS.

Parameter	This work	Meza-Cuevas et al. [32]	Shendkar et al. [33]	Wang et al. [34]	Jovičić et al. [35]
Size	11cm diameter, 5cm height (main module)	16 x 8 x 2.5 cm ³	N/A	17 x 7.5 x 1 cm ³	7 x 2.5 x 3 cm ³
Weight (g)	125 (without batteries) 159 (with batteries)	272.6	N/A	85	45
Body part target	Upper Limbs (Lower Limbs electronics ready)	Upper Limbs (forearm)	Lower Limbs (legs)	Upper Limbs (arms)	Upper Limbs (arms)
Power Consumption	Sleep: 6.9 μ W, Idle: 185mW Active: 320mW@20mA stim.	1.17W ^a	N/A	720mW	700mW
Battery Powered	Yes, 3X AAA	Yes, 9V	Yes	Yes, 12V 500mAh Li-Po	Yes, Li-ion 500mAh
Wireless Connectivity	Yes, Bluetooth 5.0	Yes, 802.15.4	No	Yes, Wi-Fi	Yes, ZigBee
Max. Stimulation Current	113mA	100mA	60mA	60mA	70mA
EMG Inputs	2 (embedded)	1 (external equipment)	0	0	0
Stimulation Outputs	1	0	1	4	1
Dedicated Base Station	No	Yes	N/A	No	Yes (Coordinator)
Pulse Width (ms)	600 (biphasic, 300 interphase) Programmable	256 (biphasic, 0 interphase) 128-1024	180 (biphasic, 20 interphase)	100-600 (biphasic)	10-1000 (monophasic)
Wearable Design	Yes, necklace, engineered design ^A	No	No	Yes, wristband, concept only	Yes, without engineered design ^A

N/A = Not Available. a = estimated given the measured 130mA through the 9V battery. A = With "engineered design" we refer to a structural design and production of design documents meeting the code and project requirements towards industrial exploitation.

rehabilitation scenarios. Inter alia, the material (Nylon 12) used for prototyping exhibits better elongation properties and superior fracture and fatigue resistance than most other additive manufacturing technologies, aligned to the final production stage to increase resilience and therefore mechanical robustness. Furthermore, given its portability, the developed FITFES device could be combined with other technological approaches to rehabilitation, such as, portable exoskeletons, robotic devices and virtual reality approaches. An example of this type of novel scenarios is shown in [30], where FES has been utilized jointly with robotics to help patients to follow particular trajectory paths. Another interesting work is [31], which implemented a high density stimulation matrix for upper limbs that took advantage of flexible PCB technology and recent ink-jet electrode printing technology advantages. However, such a high-density electrode matrix was stimulated using an external RehaStim commercial stimulator and the stimulation electronics had not been integrated onto the electrode array to become wearable.

Tab. I, compares the main ergonomic and electronic features of FITFES with respect to other FES devices in literature. To the best of our knowledge, besides MeCFES, no device integrating an EMG amplification system is available, and state-of-the-art works typically rely on external EMG systems to implement feedback on muscles. Based on its performance, which was characterised through laboratory measurements, FITFES can deliver high stimulation currents and consequently high overdrive voltage capabilities at the output stage. Compared to typical power consumption of available devices, the results obtained with the FITFES are also very promising given that only 320 mW are required for a 20 mA stimulation current. Unfortunately, it is not possible to further detail the

comparison analysis on power consumption due to the lack of specifications of operating conditions for the other devices reported in literature. A relevant engineering aspect is the requirement of using a dedicated base-station for ZigBee and 802.15.4 devices, as they are not typically embedded in consumer smartphones and tablets, thus impacting on the overall system flexibility. Furthermore, compared to [36], in which only the stimulation electronics is provided (designed to be AC powered), FITFES takes advantage of the progress of MeCFES circuitry to achieve higher stimulation currents (up to 113 mA) and lower power consumption (0.32 W versus 5.6 W). As a general viewpoint, the autonomy of a wearable device mainly depends on the battery capacity, besides the specific electronic design. A trade-off on battery design was adopted to allow sufficient autonomy, while keeping at the same time the overall weight low. Indeed, the achieved device weight, i.e. 159 g, is in the same order of magnitude of currently available smartphones and can therefore be worn in a necklace layout fashion without problems, even for prolonged rehabilitation sessions. Furthermore, the achieved result suggests that this design has room for increasing battery capacity, in case the resulting operation time needs to be expanded further. Based on these considerations, we can state that the FITFES system is best in its class in providing high stimulation currents compared to the state-of-the-art. Moreover, FITFES is the only portable FES in literature capable of acquiring EMG signals directly and of giving 300 V stimulation across the electrodes. Thanks to this high voltage overdrive, we have achieved high stimulation current levels, which can possibly be applied also to lower limbs, applying again the herein presented user-aware methodology to extract the ergonomic implications and resulting design requirements.

FITFES is based on the results and the electronic solutions previously developed for the McCFES, that has already been subject to a number of clinical studies [6], [14], [16], [20]. However, to further quantify the mechanical usability of the FITFES and its performance through a real user experience, further studies have to be carried out to characterise its performance directly on patients. This would allow the validation of the proposed design flow based on direct feedback from the users, both therapists and patients.

VII. CONCLUSION

We have developed a novel EMG controlled FES stimulation device, FITFES, using a user-centered approach with focus on wearability and simplicity to facilitate its use in rehabilitation. Based on users' requirements, it has been embodied in a necklace as a circular case integrating one stimulation channel and two EMG channels. It has a size of 11 cm diameter, 5 cm height and a weight of 159 g. The electrical specifications were validated and delivery of perfectly balanced bipolar stimulation current pulses of up to 113 mA with a maximum differential voltage of 300 V are confirmed. The power consumption for typical clinical usage (which requires delivery of 20 mA stimulation) is 320 mW, whereas in *Sleep Mode* it consumes less than 10 μ W. This makes it comparable with the state-of-the-art devices, paving the way for commercial deployment. Including end users early in the design phase should ensure a successful uptake by rehabilitation specialists.

REFERENCES

- [1] J. M. Veerbeek *et al.*, 'What is the evidence for physical therapy poststroke? A systematic review and meta-analysis', *PLoS One*, vol. 9, no. 2, p. e87987, 2014.
- [2] K. L. de Gooijer-van de Groep, J. H. de Groot, H. van der Krogt, E. de Vlucht, J. H. Arendzen, and C. G. Meskers, 'Early shortening of wrist flexor muscles coincides with poor recovery after stroke', *Neurorehabil. Neural Repair*, vol. 32, no. 6–7, pp. 645–654, 2018.
- [3] J. Roh, W. Z. Rymer, E. J. Perreault, S. B. Yoo, and R. F. Beer, 'Alterations in upper limb muscle synergy structure in chronic stroke survivors', *J. Neurophysiol.*, vol. 109, no. 3, pp. 768–781, 2013.
- [4] N. A. Lannin, A. Cusick, A. McCluskey, and R. D. Herbert, 'Effects of splinting on wrist contracture after stroke: a randomized controlled trial', *Stroke*, vol. 38, no. 1, pp. 111–116, 2007.
- [5] M. C. Hammond, S. S. Fitts, G. H. Kraft, P. B. Nutter, M. J. Trotter, L. M. Robinson, 'Co-contraction in the hemiparetic forearm: quantitative EMG evaluation.', *Arch. Phys. Med. Rehabil.*, vol. 69, no. 5, pp. 348–351, 1988.
- [6] J. Jonsdottir *et al.*, 'Arm rehabilitation in post stroke subjects: A randomized controlled trial on the efficacy of myoelectrically driven FES applied in a task-oriented approach', *PLoS One*, vol. 12, no. 12, p. e0188642, 2017.
- [7] A. Sarasola-Sanz *et al.*, 'Design and effectiveness evaluation of mirror myoelectric interfaces: a novel method to restore movement in hemiplegic patients', *Sci. Rep.*, vol. 8, no. 1, pp. 1–13, 2018.
- [8] A. Sunderland, D. J. Tinson, E. L. Bradley, D. Fletcher, R. L. Hewer, and D. T. Wade, 'Enhanced physical therapy improves recovery of arm function after stroke. A randomised controlled trial.', *J. Neurol. Neurosurg. Psychiatry*, vol. 55, no. 7, pp. 530–535, 1992.
- [9] S. L. Wolf and S. A. Binder-Macleod, 'Electromyographic biofeedback applications to the hemiplegic patient: changes in upper extremity neuromuscular and functional status', *Phys. Ther.*, vol. 63, no. 9, pp. 1393–1403, 1983.
- [10] R. Merletti and L. L. Conte, 'Advances in processing of surface myoelectric signals: Part 1', *Med. Biol. Eng. Comput.*, vol. 33, no. 3, pp. 362–372, 1995.
- [11] L. L. Baker, C. Wederich, D. R. McNeal, C. J. Newsam, and R. L. Waters, *Neuro muscular electrical stimulation: a practical guide*. Los Amigos Research & Education Institute, 2000.
- [12] I. D. Swain and P. N. Taylor, 'The clinical use of functional electrical stimulation in neurological rehabilitation', *Horiz. Med.*, vol. 16, pp. 315–322, 2004.
- [13] S. Saxena, S. Nikolić and D. Popović, 'An EMG-controlled grasping system for tetraplegics', *J Rehabil Res Dev*, vol.32, no.1, pp.17–24, 1995.
- [14] R. Thorsen *et al.*, 'Myoelectrically driven functional electrical stimulation may increase motor recovery of upper limb in poststroke subjects: A randomized controlled pilot study', *J. Rehabil. Res. Dev.*, vol. 50, no. 6, pp. 785–794, 2013.
- [15] Y. Hara, S. Ogawa, and Y. Muraoka, "Hybrid power-assisted functional electrical stimulation to improve hemiparetic upper-extremity function," *Amer. J. Phys. Med. Rehabil.*, vol. 85, no. 12, pp. 977–985, 2006.
- [16] G. Perini *et al.*, 'Sequentially applied myoelectrically controlled FES in a task-oriented approach and robotic therapy for the recovery of upper limb in post-stroke patients: A randomized controlled pilot study', *Technol. Health Care*, vol.29, no.3, pp.419–429, 2021.
- [17] M. Sun *et al.*, 'FES-UPP: a flexible functional electrical stimulation system to support upper limb functional activity practice', *Front. Neurosci.*, vol. 12, p. 449, 2018.
- [18] R. Thorsen, D. Dalla Costa, E. Beghi, and M. Ferrarin, 'Myoelectrically Controlled FES to Enhance Tenodesis Grip in People With Cervical Spinal Cord Lesion: A Usability Study', *Front. Neurosci.*, vol. 14, p. 412, 2020.
- [19] T. A. Perkins, 'Impedances of common surface stimulation electrodes'. In: 9th Annual Conference of the International FES Society, 2004.
- [20] R. Thorsen, R. Spadone, and M. Ferrarin, 'A pilot study of myoelectrically controlled FES of upper extremity', *IEEE Trans. Neural Syst. Rehabil. Eng.*, vol. 9, no. 2, pp. 161–168, 2001.
- [21] J. G. Webster, *Medical instrumentation: application and design*. John Wiley & Sons, 2009.
- [22] K. Takeda, G. Tanino, and H. Miyasaka, 'Review of devices used in neuromuscular electrical stimulation for stroke rehabilitation', *Med. Devices Auckl. NZ*, vol. 10, p. 207, 2017.
- [23] "Neuromove" Zynex Medical, [Online]. Available: <https://www.zynex.com/products/neuromove/>. [Accessed 26-5-2021]
- [24] Saebo Inc., "Saebo Myotrac Infinity Brochure" [Online]. Available: <https://www.saebo.com/wp-content/uploads/2016/01/Saebo-MyoTrac-Infinity-Brochure.pdf>. [Accessed 26-5-2021]
- [25] "Biomove Pro Device" Curatron Ltd., [Online]. Available: <https://mail.biomove.com/stroke-rehabilitation-device.html>. [Accessed 26-5-2021]
- [26] Otto Bock Healthcare Products GmbH, "User Manual - STIWELL med4" [Online]. Available: <https://manualzz.com/doc/7044296/stiwell-med4>. [Accessed 26-5-2021].
- [27] Myndtec Inc, "MyndMove," [Online]. Available: <https://www.myndtec.com/>. [Accessed 26-5-2021].
- [28] J. Hoyo, H. Calleja and J. Arau, "Study of an AC-AC flyback converter operating in DCM," *IEEE Annual Conference on Power Electronics Specialist*, vol. 2, pp. 683–688, 2003.
- [29] R. Thorsen and M. Ferrarin, 'Battery powered neuromuscular stimulator circuit for use during simultaneous recording of myoelectric signals', *Med. Eng. Phys.*, vol. 31, no. 8, pp. 1032–1037, 2009.
- [30] P. Sampson *et al.*, 'Using functional electrical stimulation mediated by iterative learning control and robotics to improve arm movement for people with multiple sclerosis', *IEEE Trans. Neural Syst. Rehabil. Eng.*, vol. 24, no. 2, pp. 235–248, 2015.
- [31] A. Crema, N. Malešević, I. Furfaro, F. Raschellà, A. Pedrocchi, and S. Micera, 'A wearable multi-site system for NMES-based hand function restoration', *IEEE Trans. Neural Syst. Rehabil. Eng.*, vol. 26, no. 2, pp. 428–440, 2017.
- [32] M. A. Meza-Cuevas, A. Gummenscheimer, D. Schroeder, and W. H. Krautschneider, 'Portable Neuromuscular Electrical Stimulator', *ICT OPEN Rotterdam Neth.*, 2012.
- [33] C. Shendkar, P. K. Lenka, A. Biswas, R. Kumar, and M. Mahadevappa, 'Design and development of a low-cost biphasic charge-balanced functional electric stimulator and its clinical validation', *Healthc. Technol. Lett.*, vol. 2, no. 5, pp. 129–134, 2015.
- [34] H.-P. Wang *et al.*, 'A wireless wearable surface functional electrical stimulator', *Int. J. Electron.*, vol. 104, no. 9, pp. 1514–1526, 2017.
- [35] N. S. Jovičić, L. V. Saranovac, and D. B. Popović, 'Wireless distributed functional electrical stimulation system', *J. Neuroengineering Rehabil.*, vol. 9, no. 1, pp. 1–10, 2012.
- [36] J. A. De Lima and A. S. Cordeiro, 'A low-cost neurostimulator with accurate pulsed-current control', *IEEE Trans. Biomed. Eng.*, vol. 49, no. 5, pp. 497–500, 2002.