



CO₂ and Radon Emissions as Precursors of Seismic Activity

Simone D’Incecco¹ · Ermioni Petraki² · Georgios Priniotakis³ · Michail Papoutsidakis³ · Panayiotis Yannakopoulos² · Dimitrios Nikolopoulos³

Received: 29 March 2021 / Revised: 22 May 2021 / Accepted: 25 May 2021
© The Author(s) 2021

Abstract

This paper reports a review on the relationship between seismic activity and the emissions of CO₂ and radon. Direct, indirect and sampling methods are mainly employed to measure CO₂ flux and concentration in seismic areas. The accumulation chamber technique is the mostly used in the literature. Radon gas emission in seismic areas can be considered as a short-term pre-seismic precursor. The study and the measurement of radon gas activity prior to earthquakes can be performed through active techniques, with the use of high-precision active monitors and through passive techniques with the use of passive detectors. Several investigators report models to explain the anomalous behavior of in-earth fluid gasses prior to earthquakes. Models are described and discussed.

Keywords CO₂ · Radon · Earthquake

1 Introduction

Earthquakes are large-scale natural phenomena which, despite their inevitable occurrence when certain geological conditions are met, are difficult to predict (Cicerone et al. 2009; Hayakawa et al. 2010). Earthquake prediction

is a challenging subject for the scientific community, with several reports on the pursuit of credible and unambiguous precursors (Cicerone et al. 2009; Khan et al. 2011; Shrivastava 2014). Given the difficulty of delineating the different stages of earthquake generation, several papers present significant research on features hidden in pre-seismic time series that can hint at the emergence of a forthcoming earthquake (Petraki et al. 2015). Based on a generalized methodology, at some phase during the preparation of an earthquake, some type of pre-seismic activity is expected that can hopefully be detected by recurrent observations in the vicinity of the epicenter of the earthquake, or near the displacement or near the fracture zone (Khan et al. 2011). Earthquake prediction is multifaceted a-priori and should, ideally, provide estimates of the time, epicenter and magnitude of occurrence, especially for strong earthquakes (Cicerone et al. 2009). It has been viewed under different aspects. One aspect is the discrimination in five steps (Hayakawa et al. 2010): (a) preparation step where maps are created of all possible focal areas with potential magnitude sizes and forecast periods; (b) long-term forecasting step up to 10 years; (c) intermediate forecasting step up to 1 year; (d) short-term forecasting step ranging from one week to one month; (e) immediate prediction step, where an earthquake is predicted within a day or less. This categorization is guided by the current level of physical understanding of the geological mechanisms leading to earthquakes and by the

✉ Simone D’Incecco
simone.dincecco@unich.it

Ermioni Petraki
epetraki@uniwa.gr

Georgios Priniotakis
gprin@uniwa.gr

Michail Papoutsidakis
mipapou@uniwa.gr

Panayiotis Yannakopoulos
pyannakopoulos@yahoo.co.uk

Dimitrios Nikolopoulos
dniko@uniwa.gr

¹ Department of Psychological, Health and Territorial Sciences, University “G. D’Annunzio” of Chieti-Pescara, via dei Vestini, 31, 66100 Chieti, Italy

² Department of Computer Engineering, University of West Attica, Agiou Spyridonos, 122 43 Aigaleo, Attica, Greece

³ Department of Industrial Design and Production Engineering, University of West Attica, Petrou Rally and Thivon 250, 122 44 Aigaleo, Attica, Greece

society's needs for a scientifically based preparedness before a strong earthquake occurrence. Hayakawa et al. (2010) reported another aspect: (1) long-term prediction between 10 and 100 years; (2) intermediate prediction between 1 and 10 years; (3) short-term prediction. The short-term forecast is the most highly regarded in terms of the protection of the general population, particularly, in very seismic areas. No one-to-one correspondence between specific seismic events and recording anomalies was established in either scheme of predictions (Nikolopoulos et al. 2014) and this should be emphasized.

In recent years, several methodologies have been published and different experimental approaches have been employed for the study of seismic activity and the discovery of credible seismic precursors. Several researchers (Dudridge and Grainger 1998; Chiodini et al. 2011; Cicerone et al. 2009) asserted that soil gas emission in seismic areas can be utilised to understand the relationship between the mechanisms of gas generation, release and migration during earthquakes. CO₂ is among the important gasses for the search of pre-seismic precursors. In addition, considering that CO₂ can be easily detected, it has also great significance for geosciences, in general. With the use of direct and indirect methods, CO₂ can be used to monitor volcanic activity (Froncini et al. 2004; Marty and Tolstikhin 1998), study the exchange of chemical compounds between soil and atmosphere (Morner and Etiope 2002; Zeebe and Caldeira 2008) and explore the relationship between CO₂ emission and the internal processes within active faults (Chiodini et al. 2004; Cioni et al. 2007; Ciotoli et al. 2016; Italiano et al. 2009; Martinelli and Plescia 2004). The majority of the studies regarding the emission of soil CO₂ in seismic areas determine both the flux and the concentration of CO₂ and other gases present in the soil using, mainly, direct methods, such as the accumulation chamber technique (Ciotoli et al. 2016; Lewicki et al. 2003; Quattrocchi et al. 2012) and the dynamic concentration technique, but also, by using indirect methods, e.g., sampling and isotopic techniques (Ciotoli et al. 1998; De Paola et al. 2011; Dudridge and Grainger 1998; Italiano et al. 2009).

Radon (²²²Rn) is a radioactive inert gas with a half-life of 3.82 days that has been acknowledged as a significant trace gas in hydrogeology, earth and atmosphere studies because of its ability to travel at comparatively long distances from its host rocks, as well as, its traceability, even, at very low levels (Richon et al. 2007). For this reason, the variations of radon and its progeny have been studied in geothermal fields (Whitehead et al. 2007), active faults (Al-Tamimi and Abumura 2001; King 1985), volcanic processes (Immè et al. 2005; Morelli et al. 2006) and in seismotectonic environments (Chyi et al. 2005; Cicerone et al. 2009; Khan et al. 2011; Majumdar 2004; Singh et al. 2010). While other gases have also been considered as

tracers of hidden faults, the bulk of related reports in the scientific literature are focused on radon (Petraki 2016; Yalm et al. 2012) and thoron (²²⁰Rn), which is the most significant isotope of radon in soil (Nikolopoulos et al. 2012). Local increase in radon emission along faults could be caused by several processes, including precipitation, atmospheric pressure and temperature changes, alteration of parent nuclide concentrations due to the differentiation of the local radium content in the soil, increase of the exposed area of faulted material by grain size reduction (Koike et al. 2009; Mollo et al. 2011), and carrier gas flux around and within fault zones (e.g., Annunziatellis et al. 2008; King et al. 1996).

The migration of CO₂ and radon gas by diffusion and/or advection along buried active faults can generate shallow anomalies with concentrations significantly higher than the background levels. These anomalies can provide reliable information about the location and the geometry of the shallow fracturing zone as well as the permeability within the fault zone (Annunziatellis et al. 2008; Baubron et al. 2002; Ciotoli et al. 2007; King et al. 1996; Sciarra et al. 2014). They can be attributed to the overall internal active fault procedures, because active faults are weak zones composed of highly fractured materials and fluids and, hence, favor gas leakage due to the increased permeability of the soil (Baubron et al. 2002).

2 Available Techniques and Methods

The measurement of CO₂ flux and CO₂ concentration in seismic areas is performed, usually, by employing both indirect and direct methods. The calculation of the CO₂ flux from the concentration gradient in the soil is an example of an indirect method (Baubron et al. 1990). According to Chiodini et al. (1998), indirect methods are based on the determination of CO₂ concentration in soil gas at different depths. Obviously, these methods can be applied only to steady-state diffusive flux measurements (Chiodini et al. 1998). In this case, the flux values are calculated according to the one-dimensional steady-state model of gas transport through a homogeneous porous medium. But this methodology requires knowledge of some soil properties like air-filled porosity, tortuosity and permeability, which are generally difficult to determine. According to Fick's first law, parameters like soil porosity ν and diffusion coefficient D are estimated following the equation:

$$\Phi_d = -\nu D(dC/d\lambda) \quad (1)$$

where the steady-state diffusive flux is Φ_d and $dC/d\lambda$ is the concentration gradient.

Regarding the advective flux, the action of the pressure gradient ($dP/d\lambda$) generates the movement and it is described by Darcy's law:

$$\Phi_a = (k/\mu)(dP/d\lambda) \quad (2)$$

where the advective flow is Φ_a , k is the permeability and μ is the viscosity of the fluid. Direct methods for the measurement of CO₂ flux from soil require dynamic or static procedures. Other methods have been developed to evaluate more accurately and make rapid flux measurements. Some of these are based on the absorption of CO₂ in a caustic solution, e.g., the alkali adsorption method (Anderson 1973; Kirita 1971) and on the measurement of the difference in CO₂ concentrations between inlet and outlet air in a closed chamber (e.g., open flow infrared gas analysis, (Nakadai et al. 1993; Witkamp and Frank 1969). Other widespread methods for measuring soil CO₂ flux are the accumulation chamber method (Chiodini et al. 1998; Norman et al. 1992; Quattrocchi et al. 2012) and the dynamic concentration method (Camarda et al. 2006; Giammanco et al. 1995; Gurrieri and Valenza 1988). The first method is based on the CO₂ accumulation rate inside an open box (chamber) of known volume. The measurement is performed at ground level and the flux value is calculated by a theoretical equation, according to the volume, pressure and temperature values of the chamber's atmosphere. The dynamic concentration method has been used in several field applications since 1988 (Badalamenti et al. 1991; Camarda et al. 2006; De Gregorio et al. 2002; Diliberto et al. 2002; Giammanco et al. 1998). This method has been, principally, applied to the monitoring of volcanic activity and in the study of the relationship between soil degassing and tectonics. The dynamic concentration method consists of measuring the CO₂ content in a mixture of air and soil gas, which is obtained by a special probe. As deduced by Gurrieri and Valenza (1988) and Camarda et al. (2006), the dynamic concentration is proportional to the soil CO₂ flux according to an empirical relationship, which is experimentally determined for CO₂ flux values ranging between

0.44 and 9.2 kg m⁻² day⁻¹ and the permeability of soil which is, typically, of the order of 24 μm². Gurrieri and Valenza (1988) suggested the use of a soil pipe installed inside the ground that it is opened at the base (1.3 cm in diameter and 50 cm long). A pre-determined flux of gas is pumped out from the base of the pipe and the CO₂ concentration of this gas is continuously measured. The obtained gas is replaced by atmospheric air entering the top of the pipe. After a given time, the CO₂ concentration reaches a constant value called "dynamic concentration (Cd)" which is proportional to the flux of CO₂ from soil. According to Camarda et al. (2006), Gurrieri and Valenza (1988) and Italiano et al. (2009), the formula to calculate the CO₂ flux with the dynamic concentration is the following:

$$\Phi_f = FC_d \quad (3)$$

where the CO₂ flux is given by Φ_f , the flow rate of the pump is F and the dynamic concentration C_d is the measured CO₂ concentration (Fig. 1a). However, to calculate CO₂ flux from soil, C_d must be multiplied by a factor which depends on the experimental device, working conditions, as well as, the physical characteristics of the soil in each measurement point. Besides, all dynamic procedures are additionally affected by possible overpressurization or depressurization of measurement device depending upon the design of the instrumental apparatus and the magnitude of the air flux chosen by the operator (Kanemasu et al. 1974).

Other researchers have performed soil CO₂ flux measurements using static techniques which utilize an alkaline solution (e.g., Cerling et al. 1991; Lieth and Quilletle 1962), or solid soda lime (Cropper et al. 1985; Edwards 1982) to absorb CO₂ that is released from the soil into an inverted and closed container. The minimum detection limit of the soda-lime technique is less than 0.7 g m⁻² day⁻¹ but the measurement time is long (typically 24 h). Another static technique for measuring the soil CO₂ flux determines the rate of increase in the CO₂ concentration within an inverted chamber placed on the soil surface. This technique, known

Fig. 1 a Sampling technique. b Accumulation chamber method. c Passive technique

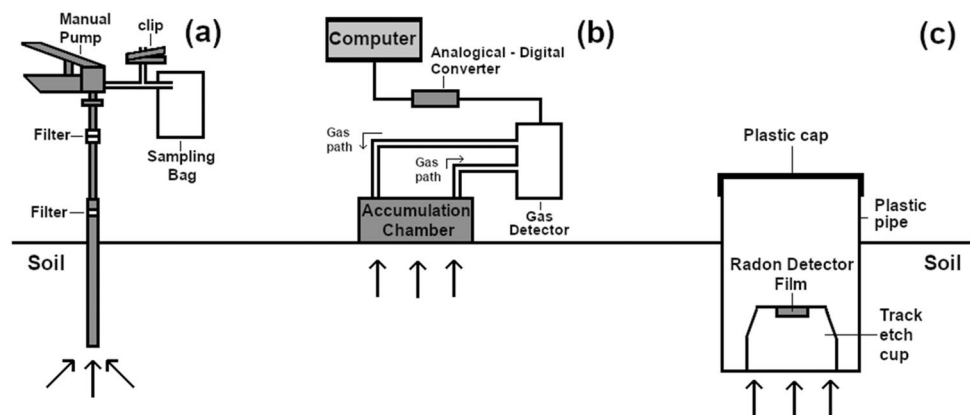

as the accumulation chamber method or closed-chamber method, has been successfully used in agricultural sciences to determine soil respiration (Bicalho et al. 2014; Panosso et al. 2012; Parkinson 1981) and to measure the flux from soil of other gaseous species, e.g., N₂O (Kinzig and Socolow 1994). Raich et al. (1990) measured CO₂ efflux rates by means of both the soda-lime method and the closed-chamber technique (using gas chromatographic determination of CO₂ concentration increase), to compare these two techniques. No consistent differences in measured soil CO₂ flux were found in the range 1.7–11.4 gm⁻²day⁻¹. According to Chiodini et al. (1998) and Quattrocchi et al. (2012), the accumulation chamber method (Fig. 1b), or “zero depth at time zero” chemical method is the best way to measure soil CO₂ flux values of volcanological-geothermal interest and seismic areas, as it is an absolute method that does not require either assumptions or corrections dependant on soil characteristics. In addition, these investigators reported that if the soil CO₂ concentration is higher than the CO₂ concentration within the air, the accumulation chamber method permits the calculation of soil CO₂ flux (Φ_{CO_2}) according to the equation:

$$\Phi_{\text{CO}_2} = aH_c \quad (4)$$

where a is the slope obtained by the relationship between CO₂ concentration and H_c is the height of the chamber.

In recent years, a new methodology concerning the evaluation of CO₂ flux is increasingly applied thanks to technological evolution and this is none other than the application of satellite observations. These kind of study depends by the applications of high-quality sensors placed on satellites to estimate CO₂ surface fluxes around the world. The Copernicus Atmosphere Monitoring Service (CAMS) allows access to satellite data acquired and permits the reconstruction of reports and maps of CO₂ gas emissions at a global scale. Moreover, the most important used satellites are owned by the Japanese Greenhouse Gases Observing Satellite (GOSAT) and NASA's second Orbiting Carbon Observatory (OCO-2). These satellites can give, in the future, important results regarding the global CO₂ efflux and, with dedicated sensors and satellites, investigate with high accuracy in selected places as seismic areas to detect possibly CO₂ flux variations from soil that could be consider as seismic precursors.

Radon flux from soil is also described similarly to the flux of CO₂, namely through Eqs. (1) and (2) (Nazaroff 1988). The methodologies described so far for CO₂ can also been applied to the estimation of radon flux from soil. However, radon measurements, due to every possible source (soil, groundwater, atmosphere, etc.), are usually performed via active and passive methods. Active techniques employ high precision and high-cost instruments while passive techniques

employ low-cost detectors (e.g., Solid State Nuclear Track Detectors (SSNTDs)) that integrate the measurements over long-time period (Fig. 1c). Active instruments provide quick measurements (from 1 to 60 min per measurement, usually, 10–15 min per measurement) that can be employed efficiently for field measurements. Active techniques do not necessitate special personnel and can also be controlled remotely (Nikolopoulos et al. 2012, 2014). On the other hand, passive techniques require specific laboratory application of certain techniques (chemical or electrochemical etching) and measurement through the optical microscope or automatic techniques, all of which need specific specialised laboratory personnel to implement. Well-known instruments for active radon measurements are the Alpha Guard (capable of measurements in soil water, groundwater and air in atmosphere), the Sarad GmbH Instruments, the Baracol VDG Instrument, the RADIM and others. All these active monitors employ certain probes that either collect through pumping and diffusion radon from soil or they measure radon in water through closed vassel circulation or water circulation.

3 CO₂-Radon Emissions Versus Seismicity

Significant information about the spatial distribution and morphology of a fracturing zone can be provided by the detection of disturbances in seismic areas. Among the various seismic precursors, CO₂ present in soil has been acknowledged as an important candidate and it is also significant in other geological applications (Cicerone et al. 2009). For example, Camarda et al. (2016) reported CO₂ flux measurements in a seismic area and outlined the importance of CO₂ flux to find credible seismic precursors (see Fig. 2). These authors reported also daily variation of soil CO₂ flux in a seismic area from 20 to 320 gm⁻²day⁻¹. De Paola et al. (2011) reported research on the behaviour of CO₂ flux from carbonate rocks stress in seismic areas. Cicerone et al. (2009) reported the importance of soil CO₂ measurements on precursory activity of impending earthquakes. Lewicki et al. (2003) reported that CO₂ flux measurements delineate the behaviour of CO₂ in seismic areas. The authors reported CO₂ values as high as 428 gm⁻²day⁻¹ near the fault zone using the accumulation chamber technique. Quattrocchi et al. (2012) reported CO₂ flux measurements using the accumulation chamber method applied to an Italian active fault area. They also reported the relationship between CO₂ flux and certain geological patterns. CO₂ flux range was from 0.134 to 1471.02 gm⁻²day⁻¹. Ciotoli et al. (2016) also reported CO₂ flux measurements in a seismic area using the accumulation chamber method. The CO₂ flux value range was from 10 to 88 gm⁻²day⁻¹. Additionally, according to Werner et al. (2014) long-term CO₂ emission can be used effectively to investigate seismicity.

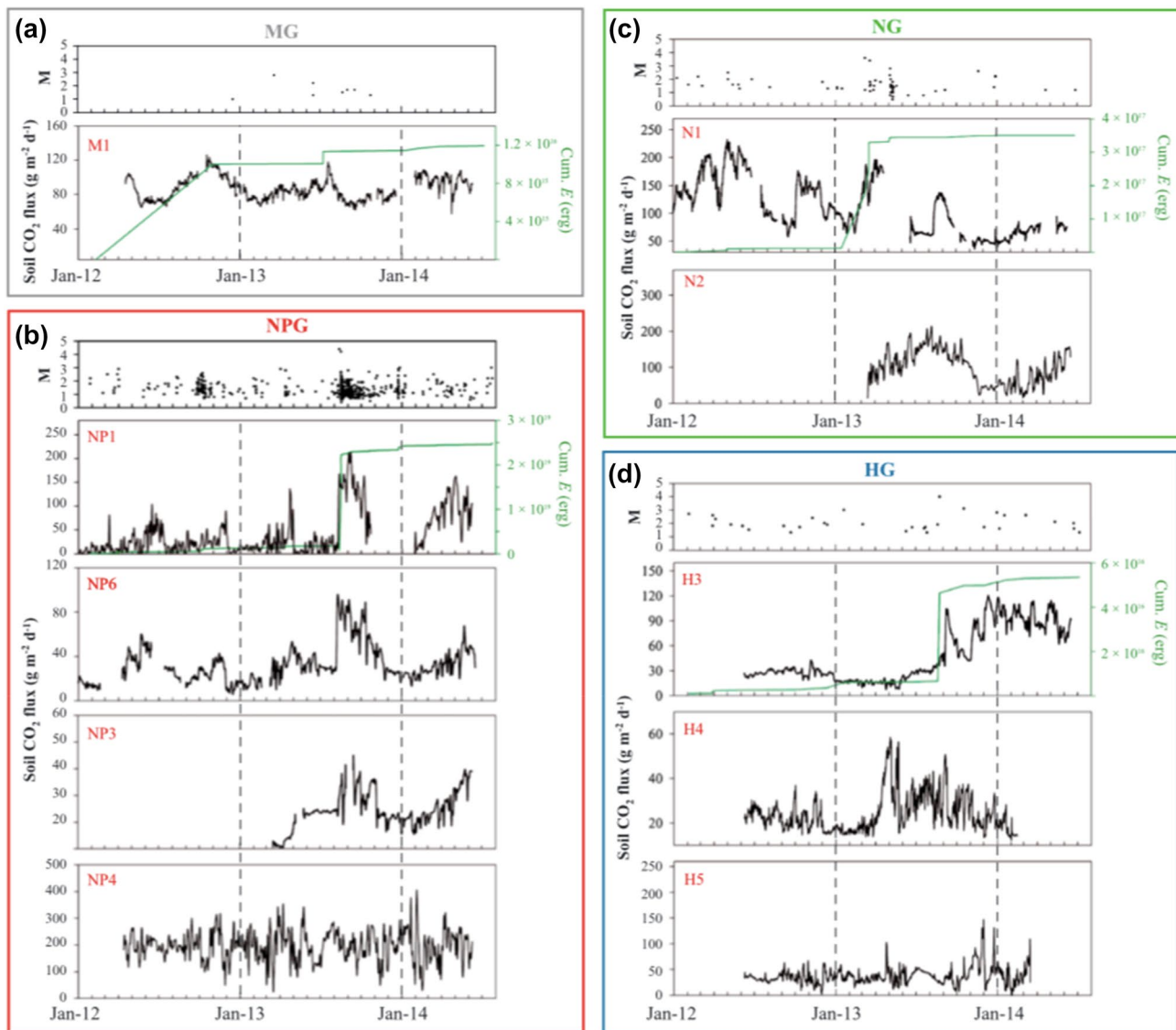

Fig. 2 Example of continuous soil CO₂ fluxes detected in four different stations related with the seismicity, from Camarda et al. (2016)

Seismic area structures are associated with scale-dependent phenomena and can be investigated with several techniques, from which, the fractal ones are of great significance. Towards this, Perfect and Kay (1995) and Eghball et al. (1999) asserted that phenomena with scale-dependent spatial variability can be studied through the concept of fractal dimension. The technique has also been applied to non-continuous spatial and temporal phenomena (Mandelbrot 1977). According to Pachepsky and Crawford (2004), fractal dimension applied to the characterization of soil can provide an evidence of scale regularity and irregular behavior. Scale dependency and spatial variability have been explored in the relationship between CO₂ flux and soil attributes (Allaire et al. 2012; Ryu et al. 2009). In addition, Panosso et al. (2012) reported that the spatial variability of

CO₂ flux is partially subject to experimental semi-variogram adjustments, which must be properly selected. This subjectivity can be attributed to the dependence of the experimental semi-variogram on grid characteristics, such as the direction and sampling distance used at the experimental site (Burrough 1981; Palmer 1988). Previous studies have used different range values of CO₂ flux for different locations, soil types and vegetation covers (Konda et al. 2008; Kosugi et al. 2007; La Scala et al. 2000; Ohashi and Gyokusen 2007). Certainly, new approaches and more research are needed to better understand the spatial variability of CO₂ flux at different scales (Bicalho et al. 2014). Some studies were carried out to understand the fractal behavior in seismic areas (Chamoli and Yadav 2015). According to Weinlich (2014) and Fisher et al. (2017), CO₂ fluxes in seismic areas can be used

to estimate the relationships between CO₂ gas emissions and seismic activity (Table 1).

Regarding radon anomalies, after decay, radon dissolves in the pores and fluids of the soil and from there to surface and underground waters and the atmosphere (Barkat et al. 2018). For example, the first evidence of anomalous radon in groundwater was, historically, found after the 1966 Great Tashkent Earthquake (Sadovsky et al. 1972). Thereafter several studies (e.g., King 1980, 1985; Ohno and Wakita 1996; Virk et al. 2001) have suggested that the fluctuation of radon concentration in water could be an effective tool for earthquake prediction. Negarestani et al. (2014) designed a continuous monitoring network for earthquake prediction studies of radon gas and concluded that such sources are useful to hot springs. Radon levels in groundwater increase before or after earthquakes in regions where high stress accumulation occurs within the earth's crust (Tarakc et al. 2014). Meteorological parameters like precipitation, temperature, humidity, pressure and local geological conditions are some of the factors that control the process of subsurface degassing which force the emanation of radon gas but the geophysical changes are the dominant factors when present (Immè and Morelli 2012). Due to this, radon in groundwater and soil has been employed extensively in earthquake prediction studies and is considered as a potentially credible short-term precursor (Cicerone et al. 2009; Petraki 2016). Significant pre-seismic radon anomalies have been reported in soil gas, thermal spas, atmosphere and groundwater (Ghosh et al. 2012; Majumdar 2004; Singh et al. 2010). It should be noted though, that there is no universal model to describe the various geo-physical mechanisms prior to earthquakes (Petraki 2016) and for this reason many papers address pre-seismic radon anomalies and try to attribute these to internal geological-geophysical processes (Table 2). In addition, some publications present noteworthy evidence of, potentially, robust criteria to recognise

pre-seismic patterns that are hidden inside the pre-seismic time-series. The concepts of fractality, self-organization and block entropy are such types of evidence (Cicerone et al. 2009; Hayakawa et al. 2010). Recent papers have outlined that the above characteristics are inherent in radon anomalies before important earthquakes that occurred in Greece (Petraki et al. 2015). Related work in Ghosh et al. (2012), also reported fractal characteristics in pre-seismic radon anomalies through Multifractal Detrended Fluctuation Analysis (MFDFA). New approaches employ Detrended Fluctuation Analysis (DFA), entropy analysis, wavelet spectral fractal analysis, Rescaled Range (R/S), whereas similarities have also been addressed between pre-seismic radon anomalies and electromagnetic disturbances in the ULF, LF and HF ranges (Petraki et al. 2015).

4 Available Models

A model that is widely used is the Dilatancy-Diffusion (DD) model (Sholz et al. 1973). The DD model relates detected abnormal radon disturbances with the growth rate of mechanical cracks within the dilatancy. A porous rock saturated with cracks is considered as the basic medium. When the tectonic stress increases, cracks develop and detach near soil pores. This renders the organization of favourably oriented cracks into a bigger crack. This decreases the pressure of the pores within the earthquake generation zone. Due to this, water flows into the generation zone from media surrounding it. As the pressure returns to trivial values, large cracks are generated that lead to abrupt changes in concentrations of soil fluids. The crack-avalanche (CA) model (Planinic et al. 2001) is also widely used. The cracks grow within a focal rock zone as the tectonic stress increases. This growth varies slowly with time. This may explain, according to the theory of

Table 1 some examples regarding CO₂ flux and seismicity are also reported the techniques used to acquire CO₂ data

Fault/locality	Historical E.Q	CO ₂ range values/CO ₂ observations	Technique used	References
Jaut Pass, French	1980 $M=5.1$	0.039–3.75%	InfraRed (IR) spectrometer	Baubron et al. (2002)
Eastern Sicily, Italy	13/12/1990 $M=5.6$	0 ppmv–20,000 ppmv	Dynamic Concentration (DC), IR	Bonfanti et al. (1993)
Central Italy	24/08/2016 $M=6.0$	10.73–88.3 (g m ⁻² day ⁻¹)	Accumulation Chamber (AC)	Ciotoli et al. (2016)
San Andreas, USA	1989 $M=7.1$	6 – 20 (g m ⁻² day ⁻¹)	Accumulation Chamber (AC)	Lewicki and Brantley (2000)
Friuli V.G., Italy	1976 $M=6.4$	200–39,100 ppm	AC, DC	Italiano et al. (2009)
L'Aquila, Italy	06/04/2009 $M=6.3$	0.134–1471.02 (g m ⁻² day ⁻¹)	Accumulation Chamber (AC)	Quattrocchi et al. (2012)
Sicily, Italy	06/09/2002 $M=5.6$	20 – 320 (g m ⁻² day ⁻¹)	Dynamic Concentration (DC), IR	Camarda et al. (2016)
Calaveras, USA	03/09/2000 $M=5.0$	10–428 (g m ⁻² day ⁻¹)	Accumulation Chamber (AC)	Lewicki et al. (2003)
Southern Taiwan	05/12/1946 $M=6.1$	0.00–21.39%	Sampling technique	Walia et al. (2010)
Val d'Agri, Italy	09/09/1998 $M=5.5$	0.039–3.1%	Gas counter	Colangelo et al. (2005)
Tuscany, Italy	27/08/2004 $M=3.7$	anomalous values 12 day before event	InfraRed (IR) spectrometer	Cioni et al. (2007)

Table 2 Some study case regarding Rn and CO₂ anomalies observed and seismicity are reported

Earthquake/locality	Magnitude (M)	Date	Gas studied	Range values (background value)	Anomaly observed	References
Kobe, Japan	7.2	17/01/95	Rn	2950 cpm (3100 cpm)	< 24 h before event	Ohno and Wakita (1996)
Chiba-ken Toho-oki, Japan	6	06/01/90	Rn	2225 cpm (2350 cpm)	2 days before event	Wakita et al. (1991)
Nagano, Japan	6.8	14/09/84	Rn	Observed gradually increase	2 weeks before event	Hirota et al. (1988)
San Andreas, USA	4.3–4.0	1978	Rn	Value of 60% above the average value	2–3 months before events	King (1980)
N-W Himalayas, India	6.5	29/03/99	Rn	Anomaly Rn observed	2 days before event	Walia et al. (2005)
N-E Italy	2.5–4.2	Dec. 1996–Mar. 1997	Rn	Anomaly Rn observed	1 month before events	Garavaglia et al. (1998)
Acapulco, Mexico	5.1	30/10/94	Rn	Anomaly Rn observed	6 days before event	Monnin and Seidel (1998)
Ashkhabad, Turkmenistan	5.2	14/03/83	Rn	Increasing Rn concentrations	1 week before event	Alekseev et al. (1995)
S-W Taiwan	11 E.Q. > 4.5	Mar. 2003–June 2004	Rn	200 kBq m ⁻³ (15 kBq m ⁻³)	1–20 days before events	Yang et al. (2005)
Kremen, Slovenia	3	28/07/00	Rn	Anomaly Rn observed	3 day before event	Zmazek et al. (2005)
Liaoyang, China	7.3	1975	Rn	Increasing Rn concentrations	6 h before event	Teng (1980)
Chengkung, Taiwan	6.8	10/12/03	Rn	12.2 Bq l ⁻¹ (28.9 Bq l ⁻¹)	45 days before event	Kuo et al. (2006)
Irpinia, Italy	6.9	23/11/80	Rn	Anomalous Rn increasing	4–5 months before event	Allegri et al. (1983)
Iceland	2.0–4.3	1978–1979	Rn	Anomaly Rn observed	17–37 days before events	Hauksson and Goddar (1981)
Afyonkarahisar, Turkey	2.6–3.9	Aug. 2009–Sept. 2010	Rn	Anomalous Rn decreasing	1–2 months before events	Yalm et al. (2012)
Krsko basin, Croatia	1.8–3.2	17–20/04/2000	Rn	Anomaly Rn observed	1–10 days before events	Gregoric et al. (2012)
Amritsar, India	5.7–6.8	26/04/1986–June 1988	Rn	Anomaly Rn observed	1–2 months before events	Singh et al. (1991)
Sicily, Italy	4.5	29/10/02	Rn	Anomaly Rn observed	1 month before event	Immè and Morelli (2012)
Bolu, Turkey	5.7	05/07/83	Rn	Anomaly Rn observed	1–20 days before events	Friedmann et al. (1988)
Central Italy	6	24/08/16	CO ₂ , Rn	CO ₂ and Rn anomaly observed	2–3 weeks after event	Ciotoli et al. (2016)
Sicily, Italy	5.6	13/12/90	CO ₂ , Rn	CO ₂ and Rn anomaly observed	1 week after event	Bonfanti et al. (1990)
West Bengal, India	3.1–5.2	Sept 2006–Aug. 2007	Rn	Increasing Rn concentrations	2–18 days before events	Ghosh et al. (2012)
Central Italy	6.3	09/04/09	CO ₂ , Rn	CO ₂ and Rn anomaly observed	1–3 weeks after events	Voltattorni et al. (2012)
S-W Greece	6.5	08/06/08	Rn	Anomaly Rn observed	1–3 months before event	Nikolopoulos et al. (2012)
S-W England	3.8	10/11/96	CO ₂ , Rn	CO ₂ and Rn anomaly observed	2 months before event	Duddridge and Grainger (1998)

stress corrosion, abnormal changes in gas concentration, under the assumption that stress corrosion is saturated with groundwater (Anderson and Grew 1977). Another model is the Lithosphere–Atmosphere–Ionosphere Coupling Model (LAIC) (Pulinets and Ouzounov 2011). LAIC model attributes stress accumulation within the ground to the movement of tectonic blocks which, consequently, result in the evolution of microcracks and, finally, fracture. The mix of microfractures and water reach the ground from various sources. According to this model, the transportation of in-earth gasses is facilitated through carrier gasses and water (Gregoric et al. 2008). Nikolopoulos et al. (2016) proposed the, so called, asperity model. This model has been used with success to explain anomalous emission of gas concentration during earthquake generation. The pre-seismic gas concentrations, are associated with fractional Brownian model (fBm) and exhibit long-memory and fractal behaviour. The model suggests that the focal area consists of a backbone of large and strong asperities that sustain the focal zone. These asperities are modelled as fBm profiles. Before the occurrence of an earthquake, the asperities are surrounded by a heterogeneous medium that blocks the asperity backbone. During this process, critical anti-persistent radon disturbances are observed. As the asperities are impacted by the abrupt tectonic stress changes of the surrounding media, they begin to break. When this happens, the breaking of the asperities backbone is unavoidable and this leads the inevitable evolution towards global failure. Other models are also proposed as well. Talwani et al. (2007) attributed the abnormal changes in gas emission to the widening of the spaces within the pores due to tectonic stress increase. Crustal activities have been also recognised with the help of radon according to related papers (Awais et al. 2017; Jilani et al. 2017; Riggio and Santulin 2015; Yu et al. 1986).

Regarding anomalous behavior of in-earth gasses and earthquake-related parameters, Rikitake (1987) suggested that the precursory time T and the magnitude M is described by equation (Ghosh et al. 2009):

$$\log T = 0.76M - 1.83 \quad (5)$$

Guha (1979) associated the precursory time, T and the magnitude, M of an earthquake as

$$\log T = A + BM \quad (6)$$

where A and B are coefficient determined statistically. Talwani (1979) suggest that the local magnitude, M_L , and the precursory duration, D , in days, can be modeled as:

$$M_L = \log D - 0.07 \quad (7)$$

All these approaches, however, are not universal and further research is needed in this field.

5 Conclusions

- 1) Earthquakes are associated with deformations within seismic preparation zones and as a result, anomalous concentrations of CO₂ and radon emissions may occur.
- 2) In seismic areas, CO₂ flux can be measured through direct and indirect methods and CO₂ concentration can be measured via sampling techniques and mainly via the accumulation chamber method.
- 3) Precursory radon activity can be measured through active techniques, with the use of high-precision active monitors and through passive techniques with the use of Solid State Nuclear Track Detectors (SSNTDs).
- 4) DD, CA and the asperity models are the most used to explain the anomalous behavior of fluid of in-earth gasses prior to earthquakes.
- 5) High-Quality Satellite observations could be used in the future as instruments to detect CO₂ flux variations in seismic areas.

Funding Open access funding provided by Università degli Studi G. D'Annunzio Chieti Pescara within the CRUI-CARE Agreement. No funding used.

Availability of data and material Not applicable.

Code availability Not applicable.

Declarations

Conflict of interest The authors declare no conflicts of interest.

Open Access This article is licensed under a Creative Commons Attribution 4.0 International License, which permits use, sharing, adaptation, distribution and reproduction in any medium or format, as long as you give appropriate credit to the original author(s) and the source, provide a link to the Creative Commons licence, and indicate if changes were made. The images or other third party material in this article are included in the article's Creative Commons licence, unless indicated otherwise in a credit line to the material. If material is not included in the article's Creative Commons licence and your intended use is not permitted by statutory regulation or exceeds the permitted use, you will need to obtain permission directly from the copyright holder. To view a copy of this licence, visit <http://creativecommons.org/licenses/by/4.0/>.

References

- Alekseev VA, Alekseeva NG, Jchankuliev J (1995) On relation between fluxes of metals in waters and radon in Turkmenistan region of seismic activity. *Radiat Meas* 25(1–4):637–639
- Allaire SE, Lange SF, Lafond JA, Pelletier B, Cambouris AN, Dutilleul P (2012) Multiscale spatial variability of CO₂ emissions and correlations with physico-chemical soil properties. *Geoderma* 170:251–260

- Allegri L, Bella F, Della Monica G, Ermini A, Improta S, Sgrigna V, Biagi PF (1983) Radon and tilt anomalies detected before the Irpinia (south Italy) earthquake of November 23, 1980, at great distances from the epicenter. *Geophys Res Lett* 10:269–272
- Al-Tamimi MH, Abumura KM (2001) Radon anomalies along faults in North of Jordan. *Radiat Meas* 34:397–400
- Anderson JM (1973) Carbon dioxide evolution from two temperate deciduous woodland soils. *J Appl Ecol* 10:361–378
- Anderson OL, Grew PC (1977) Stress corrosion theory of crack propagation with applications to geophysics. *Rev Geophys* 15(1):77–104
- Annunziatellis A, Beaubien SE, Bigi S, Ciotoli G, Coltella M, Lombardi S (2008) Gas migration along fault systems and through the vadose zone in the Latera caldera (central Italy): implications for CO₂ geological storage. *Int J Greenh Gas Control* 2:353–372
- Awais M, Barkat A, Ali A, Rehman K, Zafar WA, Iqbal T (2017) Satellite thermal IR and atmospheric radon anomalies associated with the Haripur earthquake (Oct 2010; Mw 5.2), Pakistan. *Adv Space Res* 60(11):2333–2344
- Badalamenti B, Gurrieri S, Nuccio PM, Valenza M (1991) Gas hazard on Vulcano island. *Nature* 350:26–27
- Barkat A, Ali A, Rehman K, Awais M, Riaz S, Iqbal T (2018) Thermal IR satellite data application for earthquake research in Pakistan. *J Geodyn*. <https://doi.org/10.1016/j.jog.2018.01.008>
- Baubron JC, Allard P, Toutain JP (1990) Diffuse volcanic emissions of carbon dioxide from Vulcano Island, Italy. *Nature* 344:51–53
- Baubron JC, Rigo A, Toutain JP (2002) Soil gas profiles as a tool to characterize active tectonic areas: the Jaut Pass example (Pyrenees, France). *Earth Planet Sci Lett* 196:69–81
- Bicalho ES, Panosso AR, Teixeira DDB, Miranda JGV, Pereira GT, La Scala N (2014) Spatial variability structure of soil CO₂ emission and soil attributes in a sugarcane area. *Agric Ecosyst Environ* 189:206–215
- Bonfanti P, D'Alessandro W, De Domenico R, Diliberto IS, Diliberto R, Giammanco S, Gurrieri S, Parello F, Valenza M (1993) Earthquake of December 13, 1990 in Eastern Sicily: some geochemical investigations. In: Proceedings: scientific meeting on the seismic protection, 12–13 July, Venice, Italy
- Burrough PA (1981) Fractal dimensions of landscapes and other environmental data. *Nature* 294:240–242
- Camarda M, Gurrieri S, Valenza M (2006) CO₂ flux measurements in volcanic areas using the dynamic concentration method: influence of soil permeability. *J Geophys Res* 111:B05202
- Camarda M, De Gregorio S, Di Martino RMR, Favara R (2016) Temporal and spatial correlations between soil CO₂ flux and crustal stress. *J Geophys Res Solid Earth* 121:7071–7085. <https://doi.org/10.1002/2016JB013297>
- Cerling TE, Solomon DK, Quade J, Bowman JR (1991) On the isotopic composition of carbon in soil carbon dioxide. *Geochim Cosmochim Acta* 55:3403–3405
- Chamoli A, Yadav RBS (2015) Multifractality in seismic sequences of NW Himalaya. *Nat Hazards* 77:s19–s32. <https://doi.org/10.1007/s11069-013-0848-y>
- Chiodini G, Cioni R, Guidi M, Raco B, Marini L (1998) Soil CO₂ flux measurements in volcanic and geothermal areas. *Appl Geochem* 13(5):543–552
- Chiodini G, Cardellini C, Amato A, Boschi E, Caliro S, Frondini F, Ventura G (2004) Carbon dioxide Earth degassing and seismogenesis in central and southern Italy. *Geophys Res Lett* 31:L07615
- Chiodini G, Caliro S, Cardellini C, Frondini F, Inguaggiato S, Matteucci F (2011) Geochemical evidence for and characterization of CO₂ rich gas sources in the epicentral area of the Abruzzo 2009 earthquakes. *Earth Planet Sci Lett* 304:389–398
- Chyi L, Quick T, Yang T, Chen C (2005) Soil gas radon spectra and earthquakes. *Terr Atmos Ocean Sci* 6:763–774
- Cicerone R, Ebel J, Britton J (2009) A systematic compilation of earthquake precursors. *Tectonophysics* 476:371–396
- Cioni R, Guidi M, Pierotti L, Scozzari A (2007) An automatic monitoring network installed in Tuscany (Italy) for studying possible geochemical precursory phenomena. *Nat Hazard* 7:405–416
- Ciotoli G, Guerra M, Lombardi S, Vittori E (1998) Soil gas survey for tracing seismogenic faults: a case study in the Fucino basin, Central Italy. *J Geophys Res* 103:23781–23794
- Ciotoli G, Lombardi S, Annunziatellis A (2007) Geostatistical analysis of soil gas data in a high seismic intermontane basin: Fucino Plain, central Italy. *J Geophys Res* 112:B05407. <https://doi.org/10.1029/2005JB004044>
- Ciotoli G, Sciarra A, Ruggiero L, Annunziatellis A, Bigi S (2016) Soil gas geochemical behaviour across buried and exposed faults during the 24th August 2016 central Italy earthquake. *Ann Geophys*. <https://doi.org/10.4401/ag-7242>
- Colangelo G, Heinicke J, Koch U, Lapenna V, Martinelli G, Telesca L (2005) Results of gas flux records in the seismically active area of Val d'Agri (Southern Italy). *Ann Geophys* 48(1):55–63
- Copernicus European Union's Earth Observation Programme (2019) New high-quality CAMS maps of carbon dioxide surface fluxes obtained from satellite observations. <https://atmosphere.copernicus.eu/new-high-quality-cams-maps-carbon-dioxide-surface-fluxes-obtained-satellite-observations>
- Cropper WP Jr, Ewel KC, Raich JW (1985) The measurement of soil CO₂ evolution in situ. *Pedobiologia* 28:35–40
- De Gregorio S, Diliberto IS, Giammanco S, Gurrieri S, Valenza M (2002) Tectonic control over large-scale diffuse degassing in eastern Sicily (Italy). *Geofluids* 2:273–284
- De Paola N, Chiodini G, Hirose T, Cardellini C, Caliro S, Shimamoto T (2011) The geochemical signature caused by earthquake propagation in carbonate-hosted faults. *Earth Planet Sci Lett* 310:225–232
- Diliberto IS, Gurrieri S, Valenza M (2002) Relationships between diffuse CO₂ emissions and volcanic activity on the island of Vulcano (Aeolian Island, Italy) during the period 1984–1994. *Bull Volcanol* 64:219–228
- Duddridge GA, Grainger P (1998) Temporal variation in soil gas composition in relation to seismicity in south-west England. *Geoscience in South-West England* 9:224–230
- Edwards NT (1982) The use of soda-lime for measuring respiration rates in terrestrial systems. *Pedobiologia* 23:321–330
- Eghball B, Hergert GW, Lesoing GW, Ferguson RB (1999) Fractal analysis of spatial and temporal variability. *Geoderma* 88:349–362
- Fischer T, Matyska C, Heinicke J (2017) Earthquake-enhanced permeability—evidence from carbon dioxide release following the ML 3.5 earthquake in West Bohemia. *Earth Planet Sci Lett* 460:60–67
- Friedmann H, Aric K, Gutdeutsch R, King CY, Altay C, Sav H (1988) Radon measurements for earthquake prediction along the North Anatolian Fault Zone: a progress report. *Tectonophysics* 152(3–4):209–214
- Fron dini F, Chiodini G, Caliro S, Cardellini C, Granieri D, Ventura G (2004) Diffuse CO₂ degassing at Vesuvio, Italy. *Bull Volcanol* 66:642–651. <https://doi.org/10.1007/s00445-004-0346-x>
- Garavaglia M, Braitenberg C, Zadro M (1998) Radon monitoring in a cave of North-Eastern Italy. *Phys Chem Earth* 23(9–10):949
- Ghosh D, Deb A, Sengupta R (2009) Anomalous radon emission as precursor of earthquake. *J Appl Geophys* 69(2):67–81
- Ghosh D, Deb A, Dutta S, Sengupta R (2012) Multifractality of radon concentration variation in earthquake related signal. *Fractals* 20:33–39

- Giammanco S, Gurrieri S, Valenza M (1995) Soil CO₂ degassing on Mt Etna (Sicily) during the period 1989–1993: discrimination between climatic and volcanic influences. *Bull Volcanol* 57:52–60
- Giammanco S, Gurrieri S, Valenza M (1998) Anomalous soil CO₂ degassing in relation to faults and eruptive fissures on Mount Etna (Sicily, Italy). *Bull Volcanol* 60:252–259
- Gregorič A, Zmazek B, Džeroski S, Torkar D, Vaupotič J (2012) Radon as an earthquake precursor—methods for detecting anomalies. In: D'Amico S (ed) *Earthquake research and analysis—statistical studies 2012, observations and planning*. InTech
- Gregorič A, Zmazek B, Vaupotič J (2008) Radon concentration in thermal water as an indicator of seismic activity. *Coll Antropol* 32(2):95–98
- Guha SK (1979) Premonitory crustal deformations, strains and seismotectonic features (b-values) preceding Koyna earthquakes. *Tectonophysics* 52(1–4):549–559
- Gurrieri S, Valenza M (1988) Gas transport in natural porous mediums: a method for measuring CO₂ flows from the ground in volcanic and geothermal areas. *Rend Soc Ital Mineral Petrol* 43:1151–1158
- Hauksson E, Goddard JG (1981) Radon earthquake precursor studies in Iceland. *J Geophys Res* 86:7037
- Hayakawa M, Hobaru Y (2010) Current status of seismo-electromagnetics for short-term earthquake prediction. *Geomat Nat Hazard Risk* 1(2):115–155
- Hirota U, Moriuchi H, Takemura Y, Tsuchida H, Fuji I and Nakamura M (1988) Anomalous high radon discharge from the Atotsugawa fault prior to the western Nagano Prefecture earthquake (m 6.8) of September 14, 1984. *Tectonophysics*. 52:147–152
- Immè G, Morelli D (2012) Radon as earthquake precursor. *Earthquake research and analysis—statistical studies, observations and planning*. Intech Open. <https://doi.org/10.5772/29917>
- Immè G, Delf SL, Nigro SL, Morelli D, Patanè G (2005) Gas radon emission related to geodynamic activity on Mt. Etna. *Ann Geophys* 48:65–71
- Italiano F, Bonfanti P, Ditta M, Petrini R, Slejko F (2009) Helium and carbon isotopes in the dissolved gases of Friuli Region (NE Italy): geochemical evidence of CO₂ production and degassing over a seismically active area. *Chem Geol* 266:76–85
- Jilani Z, Mehmood T, Alam A, Awais M, Iqbal T (2017) Monitoring and descriptive analysis of radon in relation to seismic activity of Northern Pakistan. *J Environ Radioact* 172:43–51
- Kanemasu ET, Powers WL, Sij JW (1974) Field chamber measurements of CO₂ flux from soil surface. *Soil Sci* 118:233–237
- Khan PA, Tripathi SC, Mansoori AA, Bhawre P, Purohit PK et al (2011) Scientific efforts in the direction of successful earthquake prediction. *Int J Geomat Geosci* 1(4):669–677
- King CY (1980) Episodic radon changes in subsurface soil gas along active faults and possible relation to earthquakes. *J Geophys Res* 85:3065–3078
- King CY (1985) Impulsive radon emanation on a creeping segment of the San Andreas fault, California. *Pure Appl Geophys* 122:340–352
- King CY, King BS, Evans WC, Zhang W (1996) Spatial radon anomalies on active faults in California. *Appl Geochem* 11:497–510. [https://doi.org/10.1016/0883-2927\(96\)00003-0](https://doi.org/10.1016/0883-2927(96)00003-0)
- Kinzig AP, Socolow RH (1994) Human impact on the nitrogen cycle. *Phys Today* 47(11):24–31
- Kirita H (1971) Re-examination of the absorption method of measuring soil respiration under field conditions. IV. An improved absorption method using a disc of plastic sponge as absorbent holder. *Jpn J Ecol* 21:119–127
- Koike K, Yoshinaga T, Asaue H (2009) Radon concentrations in soil gas, considering radioactive equilibrium conditions with application to estimating fault zone geometry. *Environ Geol* 56:1533–1549
- Konda R, Ohta S, Ishizuka S, Aria S, Ansori S, Tanaka N, Hardjono A (2008) Spatial structures of N₂O, CO₂ and CH₄ fluxes from Acacia mangium plantation soils during a relatively dry season in Indonesia. *Soil Biol Biochem* 40:3021–3030
- Kosugi Y, Mitani T, Ltoh M, Noguchi S, Tani M, Matsuo N, Takanashi S, Ohkubo S, Nik AR (2007) Spatial and temporal variation in soil respiration in a Southeast Asian tropical rainforest. *Agric for Meteorol* 147:35–47
- Kuo T, Fan K, Kuochen H, Han Y, Chu H, Lee Y (2006) Anomalous decrease in groundwater radon before the Taiwan M = 6.8 Chengkung earthquake. *J Environ Radioact* 88:101–106
- La Scala N Jr, Marques J Jr, Pereira GT, Corà JE (2000) Short-term temporal changes in the spatial variability model of CO₂ emissions from a Brazilian bare soil. *Soil Biol Biochem* 32:1459–1462
- Lewicki JL, Brantley SL (2000) CO₂ degassing along the San Andreas fault, Parkfield, California. *Geophys Res Lett* 27(1):5–8
- Lewicki JL, Evans WC, Hillel GE, Sorey ML, Rogie JD, Brantley SL (2003) Shallow soil CO₂ flow along the San Andreas and Calaveras Faults, California. *J Geophys Res* 108(B4):2187
- Lieth H, Ouellette R (1962) Studies on the vegetation of the Gaspe Peninsula. II. The soil respiration of some plant communities. *Can J Bot* 40:127–140
- Majumdar K (2004) A study of fluctuation in radon concentration behaviour as an earthquake precursor. *Curr Sci* 86:1288–1292
- Mandelbrot BB (1977) *Fractals: form, chance, and dimension*. W.H. Freeman, San Francisco, p 365
- Martinelli G, Plescia P (2004) Mechanochemical dissociation of calcium carbonate: laboratory data and relation to natural emissions of CO₂. *Phys Earth Planet Inter* 142:205–214
- Marty B, Tolstikhin IN (1998) CO₂ fluxes from mid-ocean ridges, arcs and plumes. *Chem Geol* 145(3–4):233–248
- Mollo S, Tuccimei P, Heap MJ, Vinciguerra S, Soligo M, Castelluccio M, Scarlato P, Dingwell DB (2011) Increase in radon emission due to rock failure: an experimental study. *Geophys Res Lett* 38:L14304
- Monnin M, Seidel JL (1998) An automatic radon probe for earth science studies. *J Appl Geophys* 39:209–220
- Morelli D, Martino SD, Immè G, Delfa SL, Nigro SL et al (2006) Evidence of soil radon as tracer of magma uprising in Mt. Etna. *Radiat Meas* 41:721–725
- Mörner NA, Etiope G (2002) Carbon degassing from the lithosphere. *Glob Planet Change* 33:185–203
- Nakadai T, Koizumi H, Usami Y, Satoh M, Oikawa T (1993) Examination of the methods for measuring soil respiration in cultivated land: effect of carbon dioxide concentration on soil respiration. *Ecol Res* 8:65–71
- Nazaroff W, Nero A (1988) *Radon and its decay products in indoor air*, 1st edn. Wiley, New York, p 518
- Negarestani A, Namvaran M, Shahpasandzadeh M, Fatemi SJ, Alavi SA, Hashemi SM, Mokhtari M (2014) Design and investigation of a continuous radon monitoring network for earthquake precursory process in Great Tehran. *J Radioanal Nucl Chem* 300(2):757–767
- Nikolopoulos D, Petraki E, Marousaki A, Potirakis S, Koulouras G, Nomicos C, Panagiotaras D, Stonham J, Louizi A (2012) Environmental monitoring of radon in soil during a very seismically active period occurred in South West Greece. *J Environ Monit* 14(2):564–578
- Nikolopoulos D, Petraki E, Voggiannis E, Chaldeos Y, Giannakopoulos P, Kottou S, Nomicos C, Stonham J (2014) Traces of self-organisation and long-range memory in variations of environmental radon in soil: comparative results from monitoring

- in Lesvos Island and Ileia (Greece). *J Radioanal Nucl Chem* 299(1):203–219
- Nikolopoulos D, Petraki E, Yannakopoulos PH, Cantzos D, Panagiou D, Nomicos C (2016) Fractal analysis of pre-seismic electromagnetic and radon precursors: a systematic approach. *J Earth Sci Clim Change*. <https://doi.org/10.4172/2157-7617.1000376>
- Norman JM, Garcia R, Verma SB (1992) Soil surface CO₂ fluxes and the carbon budget of a grassland. *J Geophys Res* 97:18845–18853
- Ohashi M, Gyokusen K (2007) Temporal change in spatial variability of soil respiration on a slope of Japanese cedar (*Cryptomeria japonica* D. Don) forest. *Soil Biol Biochem* 39:1130–1138
- Ohno M, Wakita H (1996) Coseismic radon changes of the 1995 Hyogo-ken Nanbu earthquake. *J Phys Earth* 44:391–395
- Pachepsky Y, Crawford JW (2004) Fractal analysis. In: Hillel D (ed) *Encyclopedia of soils in the environment*, vol 2. Academic Press, Waltham, pp 85–98
- Palmer MW (1988) Fractal geometry: a tool for describing spatial patterns of plant communities. *Vegetation* 75:91–102
- Panosso AR, Perillo LI, Ferraudo AS, Pereira GT, Miranda JGV, La Scala N (2012) Fractal dimension and anisotropy of soil CO₂ emission in a mechanically harvested sugarcane production area. *Soil Till Res* 124:8–16
- Parkinson KJ (1981) An improved method for measuring soil respiration in the field. *J Appl Ecol* 18:221–228
- Perfect E, Kay BD (1995) Applications of fractals in soil and tillage research: a review. *Soil Till Res* 36:1–20
- Petraki E (2016) Electromagnetic radiation and Radon-222 gas emissions as precursors of seismic activity. A Thesis submitted for the Degree of Doctor of Philosophy, Department of Electronic and Computer Engineering, Brunel University, London, UK
- Petraki E, Nikolopoulos D, Nomicos C, Stonham J, Cantzos D et al (2015) Electromagnetic pre-earthquake precursors: mechanisms, data and models—a review. *J Earth Sci Clim Change* 6(282):1–11
- Planinić J, Radolić V, Lazanin Z (2001) Temporal variations of radon in soil related to earthquakes. *Appl Radiat Isot* 55(2):267–272
- Pulinets S, Ouzounov D (2011) Lithosphere–atmosphere–ionosphere coupling (LAIC) model: a unified concept for earthquake precursors validation. *J Asian Earth Sci* 41(4):371–382
- Quattrocchi F, Pizzi A, Gori S, Boncio P, Voltattorni N, Sciarra A (2012) The contribution of fluid geochemistry to define the structural patterns of the 2009 L'Aquila seismic source. *Ital J Geosci (boll Soc Geol It)* 131:448–458. <https://doi.org/10.3301/IJG.2012.31>
- Raich JW, Bowden RD, Steudler PA (1990) Comparison of two static chamber techniques for determining carbon dioxide efflux from forest soils. *Soil Sci Soc Am J* 54:1754–1757
- Richon P, Bernard P, Labed V, Sabroux J, Beneito A et al (2007) Results of monitoring ²²²Rn in soil gas of the Gulf of Corinth region, Greece. *Radiat Meas* 42:87–93
- Riggio A, Santulin M (2015) Earthquake forecasting: a review of radon as seismic precursor. *Bollettino Di Geofisica Teorica Ed Applicata* 56(2):95–114
- Rikitake T (1987) Earthquake precursors in Japan: precursor time and detectability. *Tectonophysics* 136(3–4):265–282
- Ryu S, Concilio A, Chen J, North M, Ma S (2009) Prescribed burning and mechanical thinning effects on below-ground conditions and soil respiration in a mixed-conifer forest, California. *For Ecol Manag* 257:1324–1332
- Sadovsky MA, Nersesov IL, Nigmatullaev SK, Latynina LA, Lukk AA, Semenov AN, Simbireva IG, Ulomov VI (1972) The processes preceding strong earthquake in some regions of Middle Asia. *Tectonophysics* 14:295–307
- Sciarra A, Fascetti A, Moretti A, Cantucci B, Pizzino L, Lombardi S, Guerra I (2014) Geochemical and radiometric profiles through an active fault in the Sila Massif (Calabria, Italy). *J Geochem Explor* 148:128–137. <https://doi.org/10.1016/j.gexplo.2014.08.015>
- Sholz CH, Sykes LR, Agrawal YP (1973) Earthquake prediction: a physical basis. *Science* 181:803–810
- Shrivastava A (2014) Are pre-seismic ULF electromagnetic emissions considered as a reliable diagnostics for earthquake prediction? *Curr Sci* 107(4):596–560
- Singh M, Ramola RC, Singh B, Virk HS (1991) Subsurface soil gas radon changes associated with earthquakes. *Int J Radiation Appl Instrumen. Part D. Nucl Tracks Radiat Meas* 19(1):417–420
- Singh S, Kumar A, Singh BB, Mahajan S, Kumar V et al (2010) Radon monitoring in soil gas and ground water for earthquake prediction studies in North West Himalayas, India. *Terr Atmos Ocean Sci* 21:685–695
- Talwani P (1979) An empirical earthquake prediction model. *Phys Earth Planet Inter* 18(4):288–302
- Talwani P, Chen L, Gahalaut K (2007) Seismogenic permeability. *Ks. J Geophys Res Solid Earth* 112(B7). <https://doi.org/10.1029/2006JB004665>
- Tarakç M, Harman C, Saç MM, İçhedef M (2014) Investigation of the relationships between seismic activities and radon level in Western Turkey. *Appl Radiat Isot* 83(Part A):12–17
- Teng T (1980) Some recent studies on groundwater radon content as an earthquake precursor. *J Geophys Res* 85:3089
- Virk HS, Walia V, Kumar N (2001) Helium/radon precursory anomalies of Chamoli earthquake, Garhwal Himalaya, India. *J Geodyn* 31:201–210
- Voltattorni N, Quattrocchi F, Gasparini A and Sciarra A (2012) Soil gas degassing during the 2009 L'Aquila earthquake: study of the seismotectonic and fluid geochemistry relation. *Ital J Geosci* Vol. 131
- Wakita H, Igarashi G, Notsu K (1991) An anomalous radon decrease in groundwater prior to an M6.0 earthquake: a possible precursor? *Geophys Res Lett* 18(4):629–632
- Walia V, Virk HS, Yang TF, Mahajan S, Walia M, Bajwa KS (2005) Earthquake prediction studies using radon as a precursor in NW Himalayas, India: a case study. *Terr Atmos Ocean Sci* 16(4). <https://doi.org/10.3319/TAO.2005.16.4.775>
- Walia V, Lin SJ, Fu CC, Yang TF, Hong WL, Wen KL, Chen CH (2010) Soil–gas monitoring: a tool for fault delineation studies along Hsinhua Fault (Tainan), Southern Taiwan. *Appl Geochem* 25:602–607
- Weinlich FH (2014) Carbon dioxide controlled earthquake distribution pattern in the NW Bohemian swarm earthquake region, western Eger Rift, Czech Republic–Gas migration in the crystalline basement. *Geofluids* 14:143–159. <https://doi.org/10.1111/gfl.12058>
- Werner C, Bergfeld D, Farrar CD, Doukas MP, Kelly PJ, Kern C (2014) Decadal-scale variability of diffuse CO₂ emissions and seismicity revealed from long-term monitoring (1995–2013) at Mammoth Mountain, California, USA. *J Volcanol Geotherm Res* 289:51–63
- Whitehead NE, Barry BJ, Ditchburn RG, Morris CJ, Stewart MK (2007) Systematics of radon at the Wairakei geothermal region, New Zealand. *J Environ Radiat* 92:16–29
- Witkamp M, Frank ML (1969) Evolution of CO₂ from litter, humus, and subsoil of a pine stand. *Pedobiology* 9:358–365
- Yalın HA, Sandıkcıoğlu A, Ertugrul O, Yıldız A (2012) Determination of the relationship between radon anomalies and earthquakes in well waters on the Akşehir-Simav fault system in Afyonkarahisar province, Turkey. *J Environ Radioact* 110:7–12. <https://doi.org/10.1016/j.jenvrad.2012.01.015>
- Yang TF, Walia V, Chyi LL, Fu CC, Chen CH, Liu TK, Song SR, Lee CY, Lee M (2005) Variations of soil radon and thoron concentrations in a fault zone and prospective earthquakes in SW Taiwan. *Radiat Meas* 40:496–502

- Yu ZK, Cai SH, Lin JT (1986) Preliminary researches on the effects of hydro geochemistry caused by explosion of two types. *Seismol Geol* 8(1):53–60
- Zeebe RE, Caldeira K (2008) Close mass balance of long-term carbon fluxes from ice-core CO₂ and ocean chemistry records. *Nat Geosci* 1:312–315
- Zmazek B, Zivcic M, Todorovski L, Dzeroski S, Vaupotic J, Kobal I (2005) Radon in soil gas: how to identify anomalies caused by earthquakes. *Appl Geochem* 20:1106–1119