

Reducing energy demand by the combined application of advanced control strategies in a full scale WWTP

G. Bertanza, P. Baroni, S. Garzetti and F. Martinelli

ABSTRACT

Two advanced control strategies were applied on the secondary and tertiary stage, respectively, of a full-scale wastewater treatment plant (WWTP). This has a nominal capacity of 330,000 population equivalent (PE), a complex configuration (having been upgraded several times along the years), and it faces significant seasonal load fluctuations (being located in a touristic area, in Northern Italy). The lifting station of the tertiary treatments (devoted to phosphorus precipitation and UV disinfection) was optimized by adjusting the pumped flowrate, depending on influent phosphorus concentration. A preliminary simulation showed that a 15% reduction of pumping energy could be achieved. This result was confirmed by field measurements. Moreover, a fuzzy control system was designed and applied to one of the six parallel nitrification reactors, yielding a reduction of more than 25% of the power requirement for aeration. Overall, the combined application of the two controllers led to a 7% reduction of the total energy consumption of the plant. This result is particularly promising given that the fuzzy controller was applied only to one of six biological reactors.

Key words | fuzzy logic, innovative controller, nitrification, phosphorus removal, power consumption, pumping

G. Bertanza (corresponding author)

S. Garzetti

F. Martinelli

DICATAM – Department of Civil, Environmental, Architectural Engineering and Mathematics, Università degli Studi di Brescia, via Branze 43, 25123, Brescia, Italy
E-mail: giorgio.bertanza@unibs.it

P. Baroni

DII – Department of Information Engineering, Università degli Studi di Brescia, via Branze 38, 25123, Brescia, Italy

HIGHLIGHTS

- Smart control strategies are required for WWTPs: fuzzy logic was adopted for aeration.
- Full scale demonstrations of control strategies are rarely described in the literature.
- A significant energy demand reduction has been achieved in a real-scale WWTP.
- The potential of plant-wide application of combined control strategies has been demonstrated.
- The designed controllers are highly adaptable, favouring applicability in other plants.

INTRODUCTION

Stricter limitations on wastewater effluent quality, together with the rising awareness of the importance of energy saving, lead to the need for a smart design in every component of a wastewater treatment plant (WWTP). Electrical energy used for water supply and wastewater

treatment worldwide represents more than 2% of the world's electrical energy consumption (Plappally & Lienhard 2012). In conventional WWTPs, electricity consumption may account for over 25% of operation expenditures (OPEX), depending on plant size, configuration and local conditions (Li *et al.* 2016; Bertanza *et al.* 2018). In particular, oxygen supply for the biological process is responsible for approximately 50–60%, or even more, of the overall energy consumption (Rosso *et al.* 2008; WEF 2009; Brandt *et al.* 2011), whereas wastewater pumping

This is an Open Access article distributed under the terms of the Creative Commons Attribution Licence (CC BY 4.0), which permits copying, adaptation and redistribution, provided the original work is properly cited (<http://creativecommons.org/licenses/by/4.0/>).

doi: 10.2166/wst.2021.109

accounts for about 15% (Soares *et al.* 2017). Actually, several investigations revealed that there is room for improving the energy efficiency of WWTPs (Foladori *et al.* 2015; Papa *et al.* 2017; Bertanza *et al.* 2018; Vaccari *et al.* 2018). Many conventional as well as innovative options aiming at reducing the power demand are available along different directions. Examples of conventional strategies are the adoption of high efficiency bubble diffusers and the use of inverters for adjusting the motor speed. More complex solutions may involve modifications of the process configuration (e.g. nitrogen removal from the recirculated liquor from the sludge line by means of partial nitrification/anammox process or the adoption of sludge pre-treatment through thermal or enzymatic hydrolysis). A further improvement direction, considered in this paper, concerns the adoption of innovative control strategies.

Over the last years, automatic control systems have been introduced and spread in this sector, aiming at reducing the energy consumption without compromising the effluent quality (Dieu *et al.* 1995; Battistoni *et al.* 2003; Gerkšič *et al.* 2006; Iordache *et al.* 2009; Olsson 2012; Åmand *et al.* 2013; Hartley 2013; WEF 2013; Beltrán *et al.* 2015). Some simplified control solutions are available on the market and can be easily applied. Nevertheless, in case of complex plant configurations and/or adoption of more sophisticated (and likely more efficient) control systems, preliminary detailed studies should be carried out. Moreover, for boosting the potential of automatic control strategies, a plant-wide application to several compartments is recommended. Results of such a combined approach in full scale WWTPs are scarcely reported in the literature. This paper aims to contribute to fill this gap.

The plant under investigation is characterized by a complex configuration, since it underwent several upgrading interventions along time. For many years, power consumption optimization has not been the main focus of plant managers, attention being addressed to tackle with progressive influent load increase, together with the adoption of stricter effluent standards. As a consequence, energy saving is now regarded as a priority. The goal of this research was to reduce the energy requirement of the plant, by introducing two innovative controllers, in two high power-demanding compartments: tertiary treatments and aerated biological reactors. Due to their high flexibility and adaptability, both controllers are applicable to a variety of other plant configurations, ensuring a potential wide interest for the results of this experience among researchers and practitioners in the field of WWTP management.

SETUP AND METHODS

The wastewater treatment plant

The WWTP hosting the research activity described in the paper is a conventional activated sludge plant (design size 330,000 people equivalent, PE), built around 1980. The original configuration consisted of three lines of primary sedimentation, four parallel biological stages, with A2O process for biological nutrient removal, eight final clarifiers and two anaerobic digesters for sludge stabilization. The current layout is pretty different, since the primary sedimentation is by-passed, two additional biological reactors and four final settlers were built, biological phosphorus removal is no more adopted, anaerobic digesters are no more in operation, a new tertiary treatment station was built. In more detail, the current plant layout is as follows:

- pre-treatments: two coarse screenings, two fine screenings, two aerated tanks for grit/sand and oil removal, two bio-filters for minimizing odour emission;
- three primary settlers from the original configuration, now used for overflow water accumulation during rain events;
- six circular biological reactors with pre-denitrification scheme;
- ten secondary settlers;
- tertiary treatments: coagulation tank, two flocculation tanks, four lamella clarifiers, eight sand filters and two channels for UV-ray disinfection.

As expected, the compartments responsible for most of the overall energy consumption are the initial wastewater lifting station, the biological reactors (including aeration, sludge and mixed liquor recirculation, mixing), the tertiary treatment stage (lifting, sludge recirculation, reagent dosage, mixing, filter backwashing, UV-ray disinfection). Data concerning the energy consumption recorded in 2018 are shown in Figure 1. The compartments considered in this research (biological reactors and tertiary treatments) accounted, on yearly basis, for almost 80% of the overall consumption: the plant energy consumption in total was 9,252 MWh, and the biological process and tertiary stage consumed 6,242 and 1,202 MWh, respectively.

Design of the control systems

In this section, the two installed control systems are described. Figure 2 shows the WWTP stages involved and the principles of the adopted control strategies.

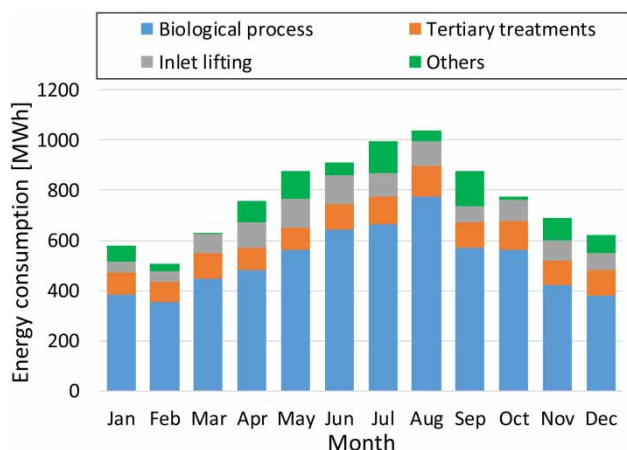

Figure 1 | Monthly energy consumption (year 2018, MWh), split in the contributions of: biological process, tertiary treatments, inlet lifting station, others.

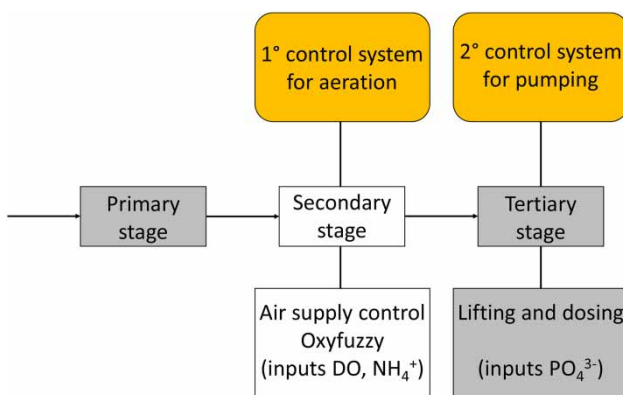

Figure 2 | The adopted control strategies and the WWTP stages involved.

Tertiary treatments

Two pumping units are in operation in the plant. The first one is devoted to raise the incoming wastewater flow. The second unit, located downstream the final clarifiers, is in charge of lifting the wastewater to feed the tertiary compartment. The optimization of the tertiary stage involved both the pumping compartment and the dosage of precipitating chemicals (aluminium sulphate is used as the coagulant, while the polyelectrolyte *Dryfloc 974*, purchased by SNF Italia srl, is the employed flocculent). In particular, the energetic costs for water lifting account approximatively for two thirds of the total OPEX of the tertiary treatments.

Nowadays, the pumps are set up to keep the raised flow rate at $4,500 \text{ m}^3/\text{h}$, when the water level in the lifting chamber is higher than 1.80 m (this level ensures the pumps to be submerged). When the incoming flow rate is higher than $4,500 \text{ m}^3/\text{h}$, the exceeding flow by-passes the tertiary treatments. In this configuration, it may happen that this

fixed flow rate is lifted even if not strictly required for complying with the effluent standards. The most striking situation occurs when the incoming concentration of the target pollutants (i.e. P and *E. coli*) is already lower than the respective thresholds fixed by law. Thus, the lifting stage was optimized using the mass balance of P as reference. The control algorithm determines how to split the incoming flow rate (Q_{in} [m^3/h]) in two flows: one to be lifted and treated in the tertiary stage (Q_{lift} [m^3/h]) and one to be by-passed ($Q_{by-pass}$ [m^3/h]). Considering the P concentration in the influent of the tertiary treatments ($[P]_{in}$ [g/m^3]) which is also equal to the concentration in the by-passed flow ($[P]_{by-pass}$ [g/m^3]), downstream the tertiary treatments ($[P]_{out_ter}$ [g/m^3]), and in the (mixed) effluent of the plant ($[P]_{out}$ [g/m^3]), the mass balance (steady state conditions) is given by Equation (1).

$$[P]_{out_ter} \cdot Q_{lift} + [P]_{in} \cdot Q_{by-pass} = [P]_{out} \cdot Q_{out} \quad (1)$$

In Figure 3, a schematic representation of the tertiary stage is given; note that online flowrate measuring sensors as well as P concentration analysers (PHOSPHAX sc, © HACH-LANGE GmbH) are installed, for plant monitoring and control.

By adopting a reasonable safety factor with respect to the legal limit, a set point for the effluent P concentration may be determined ($[P]_{out_SP}$ [g/m^3]). A suitable value of P concentration to be achieved by the tertiary treatments ($[P]_{out_ter_SP}$ [g/m^3]) may also be decided by the operator. The dosage of chemicals during the coagulation-flocculation stage will be adjusted consequently, as described below. It is assumed that $Q_{in} = Q_{out}$ (water volume used for filter backwashing is neglected). Q_{in} is measured as well as $[P]_{in}$. Therefore, the only unknown variable of the mass balance

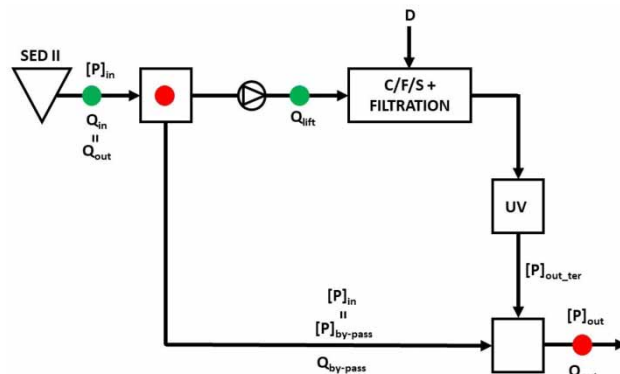

Figure 3 | Schematic representation of the tertiary treatment stage. SED II = secondary sedimentation; C/F/S = coagulation, flocculation, sedimentation; D = reagent dosage. Other symbols described in the main text. Green dots: flowrate measurement; red dots: analysers for P concentration measurement.

is the flow rate Q_{P_lift} (m^3/h) to be raised (Equation (2)): the subscript 'P_lift' is used for the flowrate, in order to specify that the calculation is based on the P mass balance.

$$Q_{P_lift} = Q_{in} \cdot \frac{[P]_{in} - [P]_{out_SP}}{[P]_{in} - [P]_{out_ter_SP}} \quad (2)$$

An analogous calculation is performed with reference to the other target pollutant (*E. coli*), to get another value of the flowrate to be lifted (Q_{EC_lift} [m^3/h]). Of course, the maximum between Q_{P_lift} and Q_{EC_lift} will be adopted as final value (Q_{max_lift} [m^3/h]).

In order to determine the required coagulant dosage, the P load to be removed by the tertiary treatments must be calculated, based on the raised flowrate (Q_{max_lift}), the influent P concentration ($[P]_{in}$) and the P concentration in the effluent of the tertiary treatments ($[P]_{out_ter}$). This coincides with the set point concentration ($[P]_{out_ter_SP}$) used in Equation (2), if the flowrate to be raised is calculated based on P mass balance ($Q_{max_lift} = Q_{P_lift}$). However, in other conditions, it may be the case that $[P]_{out_ter}$ is different from $[P]_{out_ter_SP}$. This can occur under the following circumstances:

- high influent P load: in this case, the wastewater to be lifted, determined on the basis of the P mass balance, exceeds the maximum of $4,500 m^3/h$, so that $Q_{max_lift} = 4,500 m^3/h$;
- low influent P load: the calculation gives a flowrate to be lifted lower than $2,000 m^3/h$, i.e. the minimum safety value established by the plant manager; in this case, it is assumed that $Q_{max_lift} = 2,000 m^3/h$
- the limiting factor is *E. coli*, instead of P, so that $Q_{max_lift} = Q_{EC_lift}$.

In all the above situations, the P concentration to be achieved in the effluent of tertiary treatments $[P]_{out_ter}$ is calculated based on Equation (3):

$$[P]_{out_ter} = \frac{[P]_{out_SP} \cdot Q_{in} - [P]_{in} \cdot (Q_{in} - Q_{max_lift})}{Q_{max_lift}} \quad (3)$$

Eventually, the chemical dosage (D [L/h]) is determined by Equation (4):

$$D = Q_{max_lift} \cdot ([P]_{in} - [P]_{out_ter}) \cdot F \cdot k \quad (4)$$

where:

- F [$\frac{L}{g}$]: coagulant stoichiometric dosage. Using aluminium sulphate solution, with a density of 1.28 kg/L and a minimum grade of 8% , the stoichiometric dosage is 0.016075 litres of solution per g of phosphorus to be removed;

- k [-]: empirical correction factor, aiming at taking into account the effect of water composition on reagent demand. It ranges from 1 to 10 and is continuously adjusted proportionally to the measured difference (ΔP) between the real P concentration in the effluent of the tertiary treatments ($[P]_{out_ter_real}$ [g/m^3]) and the desired one ($[P]_{out_ter}$). $[P]_{out_ter}$ and $[P]_{out_ter_real}$ are calculated using Equations (3) and (5), respectively:

$$[P]_{out_ter_real} = \frac{Q_{in} \cdot ([P]_{out} - [P]_{in}) + Q_{lift} \cdot [P]_{in}}{Q_{lift}} \quad (5)$$

Before applying the control system on the real plant, a simulation was performed to assess in advance the expected performances over a one year period (loading conditions are variable due to the location of the plant in a touristic area). The simulation consisted in the calculation, on a spreadsheet, of monthly mass balances, determined on the basis of the plant behaviour recorded in a typical working day selected within each month. In short, starting from the analysis of the influent pollutants load over the year, the raised flowrate and the reagent consumption were estimated for the controlled process. The wastewater volume to be raised was easily calculated, by applying the mass balance equations. On the contrary, the coagulant consumption was not determined using equations, because it depends on many factors beside the P mass balance, and is continuously adjusted by the controller. Therefore, the coagulant consumption was estimated considering the amount of coagulant dosed per kg of P removed, based on historical data. Finally, regarding the flocculent consumption, the simulation was carried out by assuming (see Equation (6)) that the reagent dosage (D_{floc_sim} [kg/h]) is proportional to the treated flowrate (Q_{treat_sim} [m^3/h]), the specific dosage per cubic meter of treated wastewater (d [kg/m^3]) being $0.3 \cdot 10^{-3} \text{ kg/m}^3$.

$$D_{floc_sim} = Q_{treat_sim} \cdot d \quad (6)$$

For cost estimation, the power consumption (P [kW]) due to wastewater pumping was calculated using Equation (7).

$$P = \frac{\gamma_w \cdot Q_{lift} \cdot \Delta H}{\eta_{pump} \cdot 3600 \frac{s}{h} \cdot 1000 \frac{W}{kW}} \quad (7)$$

where:

- γ_w is the specific weight of water, assumed as $9,810 \text{ N/m}^3$;

- η_{pump} is the efficiency of the pumps, assumed as 65%;
- ΔH is the head that must be overcome, equal to 5.3 m.

Given the hourly values of the flowrate, the corresponding power consumption was calculated using Equation (7). The hourly energy consumption (kWh) was then determined as the product (P [kW] \cdot 1 [h]). Summing hourly consumption values, daily and yearly energy consumption values were determined.

Eventually, the annual cost (Cost [€/y]) related to lifting was calculated as:

$$\text{Cost} = E \cdot \text{PrEn} \quad (8)$$

where PrEn is the price of energy (0.15 €/kWh).

The following specific reagent costs were assumed: 0.075 €/kg for the coagulant and 2.69 €/kg for the flocculent.

Nitrification reactor

Concerning air supply in the biological reactor, in general, the most commonly adopted control strategy consists in keeping dissolved oxygen (DO) concentration as close as possible to a fixed set point, by using a feedback chain. Traditional controllers such as proportional integral (PI) or proportional integral derivative (PID) are used in most cases (Åmand *et al.* 2013). The limitations of such a simple approach are documented in the literature (Beltrán *et al.* 2015), where issues like lack of flexibility, process instability, low energetic efficiency are reported. Since the activated sludge treatment is a complex system with variable boundary conditions and a living biomass, with a range of time constants, and never reaches steady-state conditions (Åmand *et al.* 2013), advanced process control strategies are required to obtain high performances.

In the present research, an advanced control system adopting a fuzzy logic strategy (called Oxyfuzzy in the following, since derived from a European patent of University of Brescia: Bertanza *et al.* 2016) was installed on the sixth biological reactor of the WWTP. A prototype application of the controller was previously tested (Baroni *et al.* 2006) and a simulation, carried out in the framework BSM2, showed high potential to reduce energy demand respect to other control strategies (Bertanza *et al.* 2020). The controller receives as inputs the effluent ammonium concentration and the ammonium variation rate and produces as output a percentage variation of the DO set point. The goal is to ensure that the effluent ammonium concentration remains within a predefined range; thus, the DO set point varies dynamically

on the basis of current process conditions. The control logic consists of a set of fuzzy rules defined by WWTP management experts and then tuned on field. More details on the controller can be found in Baroni *et al.* (2006).

The studied biological reactor has a volume of 7,250 m³ (2,165 m³ intended for the denitrification phase and 5,085 m³ for nitrification) and is equipped with 1,696 high efficiency fine bubble plate diffusers. Air is supplied by a volumetric blower, with an inverter for the variation of the impeller velocity. The blower, with a flowrate of 7,000 Nm³/h, is exclusively dedicated to the sixth oxidation tank during the summer period, whereas in the winter period it is shared between the fifth and the sixth oxidation tanks. The blower was previously governed by a traditional PI controller in charge of keeping a fixed DO concentration in the biological reactor. The original configuration is reported in Figure 4: the DO concentration is measured at the intermediate section of the biological reactor, by means of a LDO - OxyMax W COS 61 (© Endress + Hauser) probe, and the value is sent to the programmable logic controller (PLC) which regulates the blower accordingly.

The main components of the Oxyfuzzy system (see Figure 4) are: an analyser (AMTAX sc, © HACH-LANGE GmbH) for measuring the effluent ammonium concentration, a DO probe, a SCADA system for data acquisition from the field, and the fuzzy controller. The actual effluent ammonium concentration and its variation rate over a period of 60 minutes are used for calculating the required percent variation of the DO set point. Every 15 minutes the new DO set point is sent to the PLC, which is in charge of keeping the desired value of DO concentration in the tank, by means of a PI controller that regulates the blower velocity.

Data regarding the operation of the previous air supply system were analysed, in order to assess the effects of the advanced controller installed during the research. As reported above, a fixed DO set point is selected by the operator depending on the influent load: during high influent load periods (summer) it is set at a value of 1.5 mg/L, whereas during the winter period it is set at 1 mg/L, thus allowing for energy saving. The typical performance of the traditional controller is shown in Figure 5: during the morning hours the DO is stable at around 1.5 mg/L (the set point), and the effluent ammonium concentration is very low. Given that the effluent ammonium concentration should not exceed 5 mg/L, as mean value over 24 h, this behaviour leads to unnecessarily high energy consumption with respect to the actual needs of the biological process. The installation of the fuzzy controller was first aimed at avoiding the energy wastage occurring in this situation. On

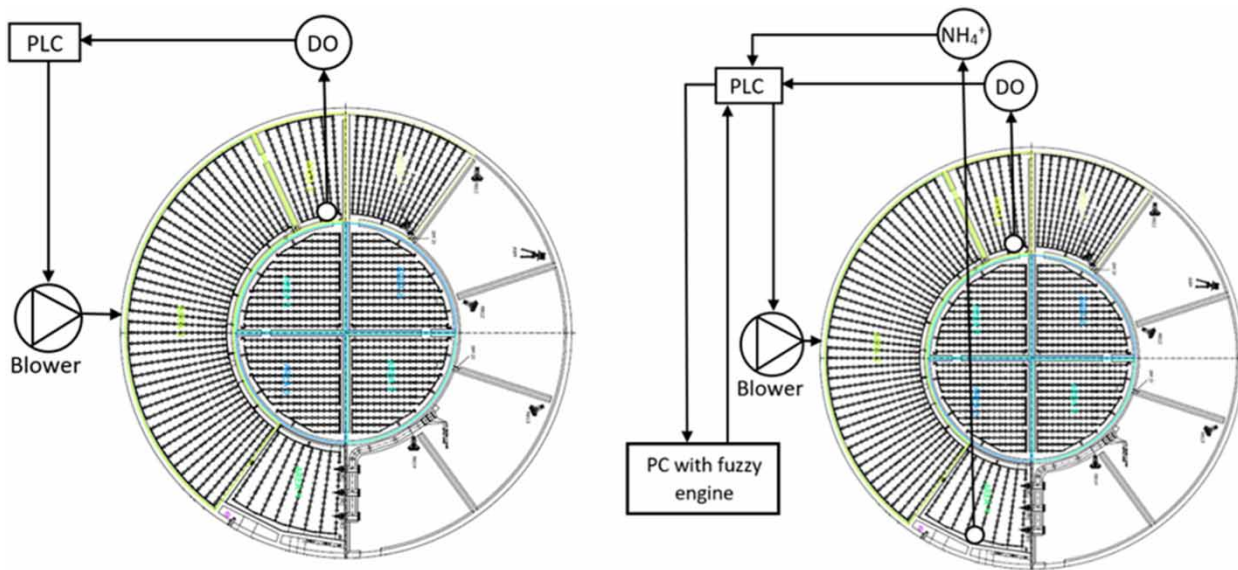

Figure 4 | **Left:** Traditional controller configuration. The DO concentration is detected and elaborated by the PLC which regulates the blower velocity, based on the fixed DO set point value. **Right:** Advanced controller configuration. Ammonium and DO concentrations are detected and sent to the PC, together with the actual blower velocity. These data are processed by the fuzzy engine which dynamically adjusts the set point and sends it to the PLC which regulates the blower velocity accordingly.

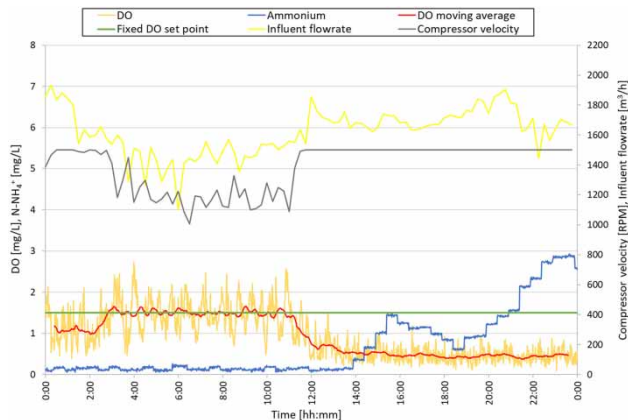

Figure 5 | Example of influent flowrate, DO and effluent N-NH_4^+ concentration, blower velocity patterns in a typical summer day, using the conventional controller (fixed DO set point) – 3 August 2019.

the other hand, in the following hours the ammonium concentration starts to increase while DO decreases at the same time, even though the compressor is operating at full regime. Of course, this shows that the air supply system is not able to satisfy the air supply needed to achieve the set point of 1.5 mg/L. However, it is also evident that keeping a DO concentration of 1.5 mg/L is not necessary to comply with the effluent ammonium concentration limit of 5 mg/L. In other words, the fixed DO set point does not correspond to the actual needs of the biological process.

The purpose of the Oxyfuzzy controller is to continuously adapt the DO concentration in the biological

reactor, in such a way that the effluent ammonium concentration remains in a predefined range: it was decided to implement fuzzy rules to keep the ammonium concentration around the value of 3 mg/L, in order to safely comply with the limit and to save energy at the same time.

The first version of the Oxyfuzzy controller was installed on the 7th of January 2020; a period of tuning followed, during which minor modifications have been applied to the fuzzy rules. In particular, the reactivity of the controller to loading condition variations has been adjusted in accordance with the *desiderata* of the plant managers, who expressed a preference for a slightly slower, hence smoother, controller behaviour with respect to the first installed version. This was meant to avoid too quick variations in process conditions and to limit mechanical stress on the components of the air supply system. The present version of the software has been put in operation on the 19th of February 2020. Moreover, since the 15th of June, periods of alternation with the traditional controller have been arranged, in order to compare the performances of two systems.

RESULTS AND DISCUSSION

Tertiary treatments

The comparison between the standard process and the simulation leads to the following results:

- regarding the lifting stage, 129 MWh can be saved in a year, which corresponds to almost 20,000 € (15% of the effective cost);
- regarding the coagulation phase, a possible reduction of dosed coagulant of almost 75 t in a year can be achieved, with a saving of approximatively 5,000 € (12% of the effective cost);
- regarding the flocculation phase, a possible reduction of dosed flocculent of 850 kg in a year can be obtained, corresponding to a saving of 3,000 € (15% of the effective cost).

By summing up all the contributions, as shown in Table 1, a reduction of the annual cost of almost 28,000 € (namely 14% of the OPEX) is expected.

Table 1 | Economic comparison between the real situation (2019) and the simulated one

	Flocculent	Coagulant	Wastewater lifting	Total
Real costs (traditional controller)	20,178 €	44,109 €	128,433 €	192,720 €
Simulation costs (advanced controller)	17,186 €	38,633 €	109,135 €	164,954 €

Due to the pandemic SARS-CoV-2 event, the tourist flow in the area was very low in summer 2020. This led to a very low influent P load during the test period. This did not allow a prolonged monitoring campaign, useful to experimentally assess the controller performance. Nevertheless, in order to evaluate the reliability of the new controller, two tests were performed on June 24, 2020, and September 17, 2020, even though the P influent concentration was low. The result of the second test is reported, as an example, in Figure 6. At the beginning of the test, the influent P concentration (in red) was around 1 mg/L, which is the maximum allowable effluent concentration. Thus, the flowrate to be lifted was calculated, by the control system, based on the P mass balance: this circumstance is evidenced by the yellow colour of the flowrate pattern in Figure 6 and by the Q symbol subscript 'P_lift'. On the contrary, when, in the subsequent hours, the influent P concentration decreased, the flowrate to be lifted was determined on the basis of the *E. coli* mass balance (the flowrate pattern is coloured in green and the Q symbol subscript is 'EC_lift'). The *E. coli* concentration during this test was assumed to be 10,000 UFC/100 mL and the abatement efficiency was assumed equal to 99.66% (the latter as the 25th percentile of historical data). Indeed, measurements of *E. coli*

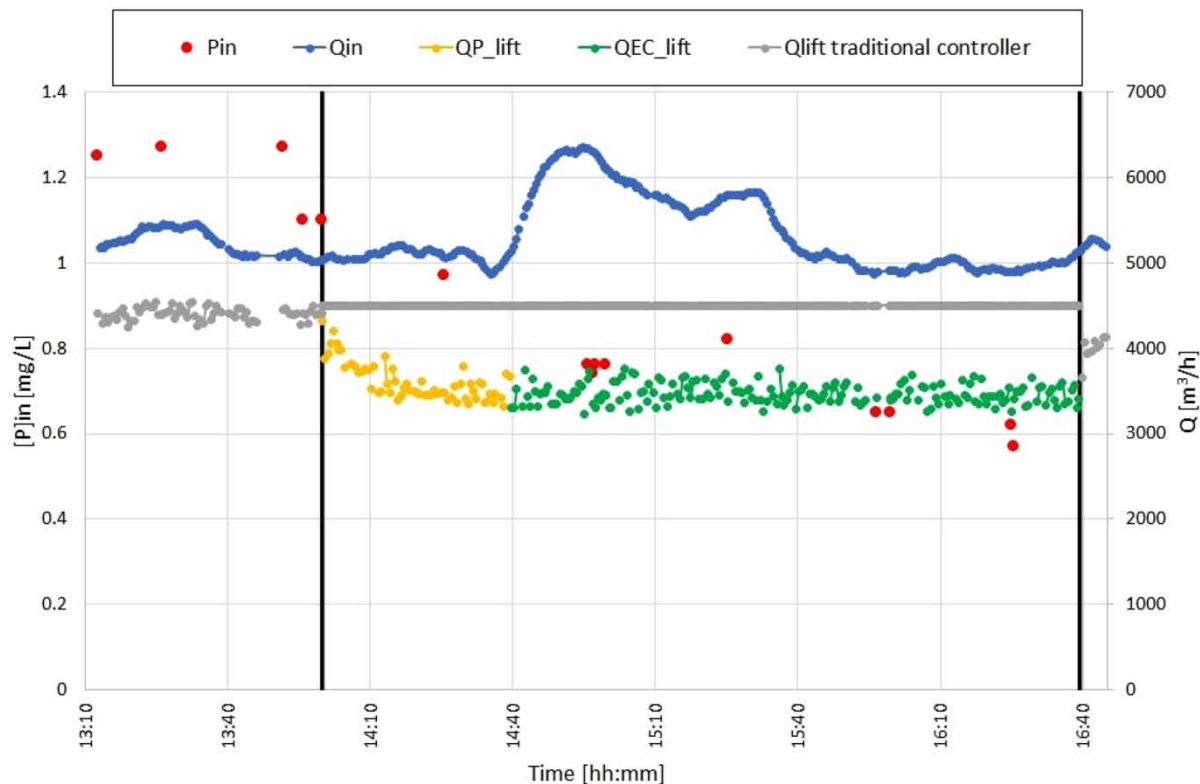

Figure 6 | Comparison between actual raised flow using the new controller and the one which would have been raised with the old controller.

concentration are not available at a frequency which could be used as a ‘continuous’ input to the controller. Thus, it was decided to assume a constant influent concentration, depending on past seasonal data.

These tests showed a reduction of the wastewater volume raised to the tertiary treatments (with respect the one which would be raised by using the previous controller) of 12% during the first trial day and of 15% during the second one. These outcomes essentially confirm the previous simulation results.

Nitrification reactor

Comparing the conventional and advanced control systems is complicated, because, as it usually happens in full-scale applications, the external conditions are continuously changing, while the comparison should be carried out under similar incoming loads. Moreover, the comparison is meaningful only if an appropriate performance of the nitrification process is ensured. Indeed, achieving energy saving while not complying with the emission limits would not be acceptable. Furthermore, if other perturbation events (e.g. overloading) occur during the monitoring campaigns, result misinterpretation may arise. In addition, in the WWTP under investigation, the loading conditions of the sixth line (which is different from the others and equipped with a more efficient final sedimentation) are continuously

adjusted by the manager in order to satisfy the operational needs of the whole plant. For these reasons, as a first approach, the behaviour of the two systems was characterised by selecting single days in which very similar influent loading conditions were recorded and working conditions were considered normal. Note, however, that the Oxyfuzzy controller was in operation under a variety of conditions and was continuously monitored by the plant staff, its performance being considered always satisfactory. However, as explained above, a reliable comparison was possible only by referring to a number of days with normal operational conditions. The Oxyfuzzy controller performance was assessed in terms of energy consumption with respect to the original controller. Moreover, the actual trend of ammonium concentration was compared with the desired one.

Figures 7 and 8 show the trends of influent flowrate, DO and effluent N-NH_4^+ concentration, blower velocity patterns and DO set point (additional examples in the Supplementary Material). It can be seen that, with both the controllers, the effluent ammonium concentration was stably below the value of 5 mg/L.

Nevertheless, with the introduction of the Oxyfuzzy controller, the ammonium concentration was kept around the value of 3 mg/L, by regulating the blower velocity on the basis of the measured values of the ammonium concentration itself, whereas in the traditional configuration it was

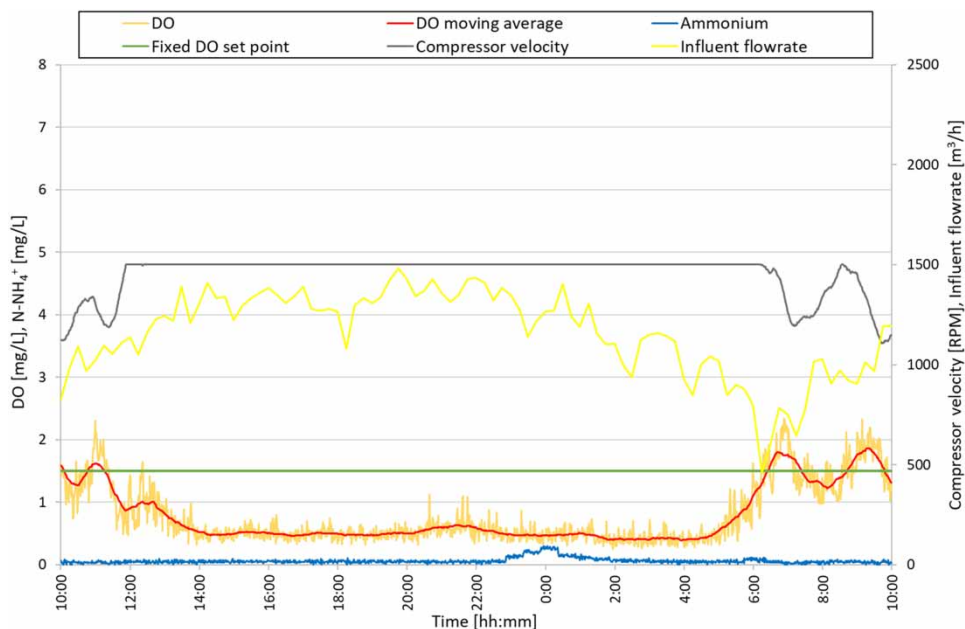

Figure 7 | Example of influent flowrate, DO and effluent N-NH_4^+ concentration, blower velocity patterns and DO set point recorded on 12/13 September 2020, using the conventional controller (fixed DO set point). Process conditions C: $T = 21.6^\circ\text{C}$, $\text{NH}_4^+_{\text{in}} = 20.1\text{ mg/L}$, blower not shared.

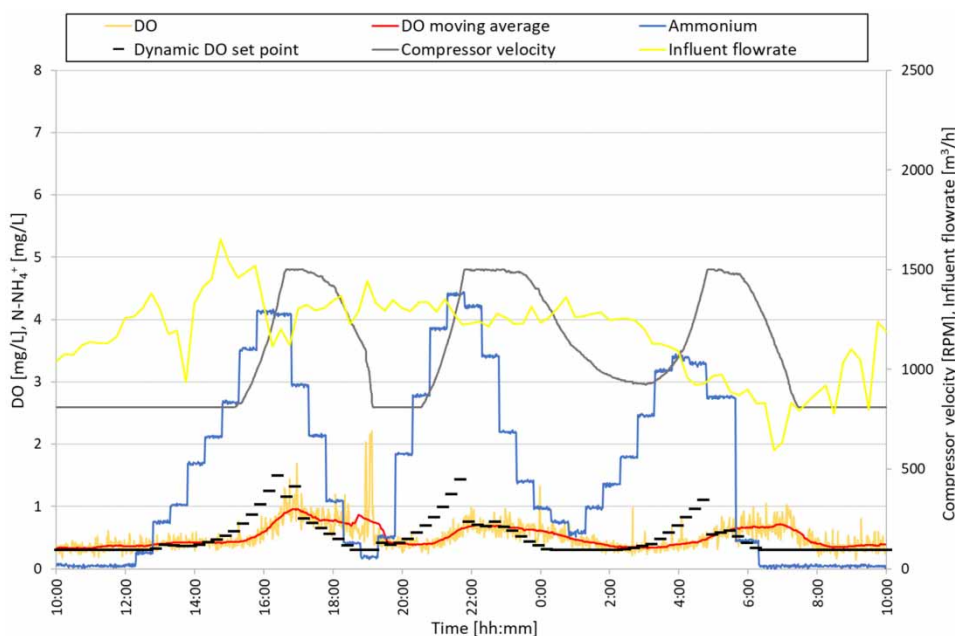

Figure 8 | Example of influent flowrate, DO and effluent N-NH_4^+ concentration, blower velocity patterns and DO set point recorded on 16/17 September 2020, using the advanced controller (dynamic DO set point). Process conditions C: $T = 21.5^\circ\text{C}$, $\text{NH}_4^+_{\text{in}} = 24\text{ mg/L}$, blower not shared.

mostly kept close to 0 mg/L in order to maintain the DO concentration around the fixed set point value.

In Figure 7 the typical behaviour of the traditional controller can be observed: the blower provides air to maintain the required DO concentration even if the effluent ammonium concentration is low, leading to an excess of energy consumption. It can be observed in particular that the fixed DO set point, which is actually not attained most of the time due to the physical limits of the air supply system, turns out to be unnecessarily high under these loading conditions. A lower DO concentration turns out to be sufficient to keep effluent ammonium concentration close to zero. On the other hand, Figure 8 reports the representative operation of the Oxyfuzzy controller: the blower velocity is at the minimum if the effluent ammonium concentration is low, while it increases when the effluent ammonium concentration rises. Slow oscillations of the effluent N-NH_4^+ concentration, roughly with a period of a few hours, can be observed. These are related to variations of the influent load and can be explained by two main facts:

- since blowers have a minimum operation speed, it is impossible to reduce air supply under a certain limit, hence very low values of effluent N-NH_4^+ concentration are attained under low load conditions;
- the plant managers required to keep effluent N-NH_4^+ concentration as close as possible to 5 mg/l, while avoiding

to overcome this threshold and, as already mentioned, expressed a preference for smoother controller reactions to load condition changes.

Altogether the controller behaviour was considered satisfactory by the plant managers, while investigating possible further improvements is left to future work.

The overall energy consumption recorded in the above days for the operation of the studied reactor (including air supply, sludge and mixed-liquor recirculation, mixers) is reported in Table 2: with the advanced controller in operation, a reduction of 20–27% was achieved. Regarding the energy consumption related to aeration, a reduction of 26–36% was achieved.

CONCLUSIONS

The implementation and setting up of combined innovative control strategies led to a reduction of the energy consumption. During the monitoring campaigns, approximately 15% saving was recorded for the lifting stage of the tertiary treatment and above 25% for the air supply in the sixth biological reactor. The corresponding reduction of the overall plant energy consumption was 7%, the fuzzy controller being applied only to one of the six biological reactors.

Table 2 | Total energy consumption of the biological process [MWh], aeration energy consumption [MWh] and specific energy consumption [MWh/m³] during days characterized by typical working conditions

	Controller	Total energy consumption [MWh]	Aeration energy consumption [MWh]	Inflow [m ³ /d]	Specific energy consumption [kWh/m ³]
14–15 June	Traditional	4.72	3.31	42,563	0.111
15–16 June	Advanced	3.73	2.27	43,582	0.086
% reduction		21%	31%		
13–14 August	Traditional	4.60	3.15	38,801	0.119
6–7 August	Advanced	3.70	2.32	38,444	0.096
% reduction		20%	26%		
12–13 September	Traditional	5.10	3.63	27,739	0.184
16–17 September	Advanced	3.70	2.32	28,283	0.131
% reduction		27%	36%		

Both controllers required a testing phase in order to evaluate the reliability of hardware and software components under significantly fluctuating load conditions.

Given the reliability shown and the savings achieved, the manager of the plant is planning to extend the implementation of the fuzzy controller in other compartments.

Even though the adopted solutions were developed and tested for the WWTP analysed, they do not include any structural feature specifically depending on this plant: the two control approaches adopted are general by nature and can be adjusted and applied with a moderate effort to a variety of configurations, where they promise to yield similarly significant energy savings.

ACKNOWLEDGEMENTS

This work was partially funded by the Italian Ministry for University and Research, within the program ‘Smart Cities and Communities and Social Innovation’, Project SWaRM-Net-Smart Water Resource Management – Networks’ (SCN_00198). The authors warmly acknowledge the management staff of the studied WWTP, as well as the management Company (which expressed intention to remain anonymous), for technical and financial support. The funders had no role in the collection, analyses, or interpretation of data; in the writing of the manuscript, or in the decision to publish the results.

DATA AVAILABILITY STATEMENT

All relevant data are included in the paper or its Supplementary Information.

REFERENCES

- Åmand, L., Olsson, G. & Carlsson, B. 2013 *Aeration control – a review*. *Water Science and Technology* **67** (11), 2374–2398.
- Baroni, P., Bertanza, G., Collivignarelli, C. & Zambarda, V. 2006 *Process improvement and energy saving in a full scale wastewater treatment plant: air supply regulation by a fuzzy logic system*. *Environmental Technology* **27** (7), 733–746.
- Battistoni, P., De Angelis, A., Boccadoro, R. & Bolzonella, D. 2003 *An automatic controlled alternate oxic-anoxic process for small municipal wastewater treatment plants*. *Industrial and Engineering Chemistry Research* **42** (3), 509–515.
- Beltrán, S., Irizar, I. & Ayesa, E. 2015 *Instrumentation, monitoring and realtime control strategies for efficient sewage treatment plant operation*. In: *Sewage Treatment Plants: Economic Evaluation of Innovative Technologies for Energy Efficiency*. IWA Publishing, London, UK, pp. 189–212.
- Bertanza, G., Zambarda, V., Baroni, P. & Collivignarelli, C. 2016 *Method and device for controlling the biological process in waste-water treatment plants*. EP1598712B1, *European Patent*.
- Bertanza, G., Canato, M. & Laera, G. 2018 *Towards energy self-sufficiency and integral material recovery in wastewater treatment plants: assessment of upgrading options*. *Journal of Cleaner Production* **170**, 1206–1218.
- Bertanza, G., Menoni, L. & Baroni, P. 2020 *Energy saving for air supply in a real WWTP: application of a fuzzy logic controller*. *Water Science and Technology* **81** (8), 1552–1557.
- Brandt, M., Middleton, R., Wheale, G. & Schulting, F. 2011 *Energy efficiency in the water industry, a Global Research Project*. *Water Practice & Technology* **6** (2).
- Dieu, B., Garrett, M. T., Ahmad, Z. & Young, S. 1995 *Applications of automatic control systems for chlorination and dichlorination processes in wastewater treatment plants*. *ISA Transaction* **34**, 21–28.
- Foladori, P., Vaccari, M. & Vitali, F. 2015 *Energy audit in small wastewater treatment plants: methodology, energy consumption indicators, and lessons learned*. *Water Science and Technology* **72** (6), 1007–1015.

- Gerkšič, S., Vrečko, D. & Hvala, N. 2006 Improving oxygen concentration control in activated sludge process with estimation of respiration and scheduling control. *Water Science and Technology* **53** (4–5), 283–291.
- Hartley, K. 2013 Process control. In: *Tuning Biological Nutrient Removal Plants*. IWA Publishing, London, UK, pp. 171–196.
- Iordache, S., Dimitru, D., Ianache, C. & Predescu, L. 2009 Developing an integrated automatic control system for wastewater treatment improvement. *Annals. Food Science and Technology* **10**, 620–623.
- Li, W., Li, L. & Qiu, G. 2016 Energy consumption and economic cost of typical wastewater treatment systems in Shenzhen, China. *Journal of Cleaner Production* **163**, S374–S378.
- Olsson, G. 2012 ICA and me – a subjective review. *Water Research* **46** (6), 1585–1624.
- Papa, M., Foladori, P., Guglielmi, L. & Bertanza, G. 2017 How far are we from closing the loop of sewage resource recovery? A real picture of municipal wastewater treatment plants in Italy. *Journal of Environmental Management* **198**, 9–15.
- Plappally, A. K. & Lienhard, J. H. 2012 Energy requirements for water production, treatment, end use, reclamation, and disposal. *Renewable and Sustainable Energy Reviews* **16**, 4818–4848.
- Rosso, D., Larson, L. E. & Stenstrom, M. K. 2008 Aeration of large-scale municipal wastewater treatment plants: state of the art. *Water Science and Technology* **57**, 973–978.
- Soares, R. B., Memelli, M. S., Roque, R. P. & Goncalves, R. F. 2017 Comparative analysis of the energy consumption of different wastewater treatment plants. *International Journal of Architecture, Art and Application* **3** (6), 79–86.
- Vaccari, M., Foladori, P., Nembrini, S. & Vitali, F. 2018 Benchmarking of energy consumption in municipal wastewater treatment plants – a survey of over 200 plants in Italy. *Water Science and Technology* **77**, 2242–2252.
- WEF 2009 *Energy Conservation in Wastewater Treatment Facilities – Manual of Practices – No. 32*. Water Environmental Federation, Alexandria, VA, USA.
- WEF 2013 *Automation of Water Resource Recovery Facilities – Manual of Practice – No. 21*. Water Environmental Federation, Alexandria, VA, USA.

First received 31 December 2020; accepted in revised form 12 March 2021. Available online 23 March 2021