

Date of publication xxxx 00, 0000, date of current version xxxx 00, 0000.

Digital Object Identifier 10.1109/ACCESS.2017.DOI

Queueing Theory based Vehicular Traffic Management System through Jackson Network Model and Optimization

MD. GOLAM RABIUL ALAM¹ (MEMBER, IEEE), TANJIM MUSHTARI SUMA¹, SK MAHTAB UDDIN¹, MD. BONY AMIN KHAN SIAM¹, MD. SHAZID BIN MAHBUB¹, MOHAMMAD MEHEDI HASSAN²(SENIOR MEMBER, IEEE) AND GIANCARLO FORTINO³(SENIOR MEMBER, IEEE)

¹Department of Computer Science and Engineering, BRAC University, Dhaka, Bangladesh

²Information Systems Department, College of Computer and Information Sciences, King Saud University, Riyadh 11543, Saudi Arabia

³Department of Informatics, Modeling, Electronics, and Systems, University of Calabria, 87036 Rende, Italy

Corresponding author: Md. Golam Rabiul Alam (e-mail: rabiul.alam@bracu.ac.bd).

This work was supported by King Saud University, Riyadh, Saudi Arabia, under Researchers Supporting Project number RSP-2021/18.

ABSTRACT Traffic congestion is increasing in over populated urban areas, our traditional traffic management system can no longer solve this problem. However, this problem can be solved by converting our road networks into queueing networks. This paper proposes, the use of an open Jackson Queueing Model which can be equated with our existing road network to calculate the waiting time of vehicles in the network, which can be further processed to put the network into an optimized state. In this model, the waiting time depends on both arrival rate and service rate. Our implementation designates a set of service rates from a range of possible service rates for each road within the network and these designated service rates are used to calculate waiting time. As these various combinations of service rates of different roads produce multiple waiting times, we select the combination set of service rates which has the lowest set of waiting times. This set of service rates is also compared with quadratic optimization problem of the same road network to evaluate implementation's accuracy.

INDEX TERMS Traffic Congestion, Queueing Model, Jackson Queueing Network, Optimization Theory, Quadratic Programming, Quadratic Optimization, Arrival rate, Service time, Mean Customer Waiting Time, Mean Number of Customers

I. INTRODUCTION

IN modern times at Dhaka city, the exponentially increasing vehicular traffic congestion has been a serious alarming factor for the entire nation. Traffic blockage is a basic situation and it has transformed into typical marvels in Bangladesh, particularly in Dhaka city. It is impeding exchange, trade, commerce as well as ruining our day-to-day life. At the point when traffic request is substantial enough that the collaboration between vehicles eases back the speed of the traffic stream, gridlock is experienced. Dhaka city has various significance in the national and territorial chain of importance. Legislative and every other capacities of the nation are decided in this capital city. Dhaka city's traffic framework is viewed as one of the most disordered ones on the planet. The occupants are constrained to experience physical pressure and endure financial losses and misfortunes regarding working and active hours lost on working days.

Newspapers, televisions, online news portals, radios have always been featuring the sufferings of the inhabitants and citizens in Dhaka city in view of the pestering traffic issue. The inhabitants are constrained to experience the torment in terms of physical and mental stress. Besides, financial setbacks are also experienced by the people and it takes a toll on their mental health as valuable working hours are lost. However, no clear answer for the issue is in sight located, at any rate, in the short and medium terms, however a great deal has been said and a large enough program, attempted with the help from a multilateral bank to improve the traffic circumstance of the capital city as of late[1]. Having a citizen count of over 18 million people, Dhaka is regarded as the biggest and most heavily inhabited cities in the world, and this number is predicted to arrive at 22 million by 2025, at an annual growth rate of 4.4% according to United Nations[2]. Dhaka megacity is regarded as one of the most

over populated cities of the world having a density of 11,910 persons per km²[2]. The density is mainly concentrated in the central regions of Dhaka city. The megacity is also regarded as the 11th largest megacity in the world according to United Nations[2]. Its quick development has made numerous difficulties; impediments and the traffic congestion are the most commonplace among these. In excess of 7 hundred thousand rickshaws handle the city street, yet just 75 thousand have legitimate number [2]. From time to time endeavors are made to decrease the number, yet the activity as a rule delivers moderate effects. Despite the fact that Dhaka has become as the Asia's least mechanical capitals, its traffic clog is the most exceedingly awful and consistently decaying. According to a report which was published by World Bank, in the past 10 years, the average traffic speed in Dhaka has dropped from 21 kilometers per hour (kph) to 7 kph, and by 2035, the speed might drop to 4 kph, which is slower than the walking speed[3]. Another study, which was conducted and commissioned by BRAC Institute of Government and Development, says traffic congestion in Dhaka eats up around 5 million working hours every day and costs the country US Dollars 11.4 billion every year. The financial loss and budgetary misfortune were calculated from an estimation of the expense of time lost in rush hour gridlock clog and the cash spent on working vehicles for the additional hours [3]. Sometime in the near past, workers and city dwellers endured traffic blockage just on the fundamental city boulevards, yet now it begins directly from one's doorstep. Car influx has transformed day by day stumbles into bad dreams. Every day, students go out to attend at their respective institutions. In most of the cases, despite the distance home to destination is often very less in terms of numbers, each trip becomes a horror story for both the student and working-class people. People face severe traffic slowdown from just outside local neighborhoods. Thousands of more examples of such misfortune and tragedy can be given which the residents of the city suffer due to this unbearable traffic congestion. This problem has turned the alarm bell on for the entire nation's economy. This is because even though Dhaka is only covering a few proportions of the country's total area, its contribution to GDP is more than the quarter proportion that of the entire nation, and it has created roughly half of the country's total employment. Traffic congestion affecting Dhaka city's working efficiency is costing the entire nation heavily. Different endeavors and steps were taken by past governments incorporating extraordinary gathering with the offices worried to devise intends to help decrease the power of traffic issue in Dhaka city. Some substantial upgrades were guaranteed inside the briefest conceivable time. In any case, in actuality nothing has occurred with the traffic police remaining uninterested, much of the time, to their standard obligation. The drivers of transports and trucks and the rickshaw pullers proceed to be as resistant as in the past. In the past legislators were regularly accused halfway for the clamorous traffic due to their supposed contribution in a billion Bangladeshi Taka cost assortment from transport

and truck proprietors and transport terminals. The guides of the overseer government were accepted to be perfect in this regard. However, there was no improvement in the traffic circumstance.

At the center of the problem of our research lies the number of vehicles in Dhaka city which is increasing at an incredible pace. According to Bangladesh Road Transport Authority (BRTA), there are around 3.1 million registered vehicles in Bangladesh and Dhaka city has around one million of them. But 5 different studies show that around 5 million vehicles, including the 3.1 million registered are currently plying on the road [3]. According to another report from BRTA, 20304 new cars were appended to Dhaka's traffic in 2016, meaning over 55 new cars hit the streets of Dhaka city every day[3]. The traffic management system at important traffic points still managed manually through blind guesses and fixed service rates at interceding points, which is not being able to handle the traffic congestion during important times and peak hours as per situation demands. These factors became the major reasons of motivation for our research. Therefore, the question that this research is trying to answer is how effective will be the combination of reducing waiting time and optimization of service time in creating impact on our traffic problem?

Through our research we addressed this problem of complex traffic congestion situation and we proposed a solution through a model which the traditional static traffic management system based on blind guesses can't resolve. The service rate of traditional traffic management system is not based on any logical data or assumption, nor any mathematical calculation whatsoever. In other words, the system is not autonomous and the traffic signals are being managed freely without any solid data or estimation.

- Constructed a generic road network model and converted it into an equivalent open Jackson Queueing Network model.
- Determined an efficient service rate based on vehicles' arrival rate.
- Optimized the overall waiting time of our road network model from the equivalent queueing network model.
- Observed negligible deviation while comparing with the solution obtained from the quadratic optimization algorithm of the same model

The paper resources are organized as follows. In Section II, a brief analysis of the previous and existing related research works is shown. Section III shows the field of analysis by introducing models and formulating the problem. Section IV contains detailed methodology of our proposed work plan and implementation details along with algorithms. The summary visualization and comparative analysis of our results which we have acquired through data simulation are shown in Section V. Finally, Section VI concludes with some final words and research findings.

TABLE 1: Comparison of Previous Works

Title	Queueing Methodology	Queueing Model
M/G/c/c state dependent queueing model for a road traffic system of two sections in tandem[4]	Queueing Network	M/G/c/c
Simulation and analysis of traffic flow models with emergency vehicles distortion on a single road[5]	Queueing System	M/M/1 M/G/1 G/G/1
Designing highway access control system using multi-class M/G/C/C state dependent queueing model and cross-entropy method[6]	Queueing System	M/G/c/c
Gis aided sustainable urban road management with a unifying queueing and neural network model[7]	Queueing Network	M/M/1/FIFO
Discussion of operational transport analysis methods and the practical application of queueing theory to stationary traffic[8]	Queueing System	M/M/∞/FIFO

II. STATE OF THE ARTS

Traffic congestion has been a topic of concern around the globe in recent times. As the number of motor vehicles around the world are continuously increasing, the congestion problem is also growing at the same rate. For this reason, extensive researches have been conducted around the globe regarding this and various solution techniques have been proposed by researchers around the globe. Some notable numbers of researches were conducted for vehicular traffic congestion while relating the road traffic model with a queueing model.

According to (Nacira Guerouahane, Djamil Aissani, Nadir Farhi and Louiza Bouallouche-Medjkoune) [4] a queueing model for road traffic was presented which preserved the finite capacity property of a real-life road system. The proposed stochastic queueing network model was based on M/G/c/c state dependent queueing model which focuses on capturing the stationary density-flow relationship in both uncongested and congestion conditions. In our proposed model, we have decided to model our queueing network based on Jackson Queueing network where each queue is a single server M/M/1 queue. Exponential distribution is used for both distribution of inter-arrival time and service time in M/M/1 queues. The exponential distribution is the probability distribution of the time between events in a Poisson point process, a process in which events occur continuously and independently at a constant average rate, which is more accurate for vehicular inter-arrival time and service time within a real-life road traffic network. Moreover, the research in [4] demonstrates and formulates the model in algebraic theorem proof, solution and statistical comparison-based manner, where the proposed model's traffic system is considered a simple two sections in tandem. Our proposed model consists of a Jackson Queueing network model where there

are multiple sections having multiple inwards and outwards possible directions for vehicular traffic, which represents a realistic road-traffic scenario. In heavily populated third world countries and megacities in near future. Our proposed model was developed based on the current vehicular traffic congestion we have in our hands which is caused within the existing complex and stochastic urban road network using a Jackson Queueing Network consisting of M/M/1 queues. The model proposed in our research attempts to minimize the average waiting time spent by vehicles within a road network by optimizing the overall mean service rate and service time within the road network. According to (S. Sumaryo, A. Halim and K. Ramli) [5], the research was conducted in Indonesia to construct a traffic model based on queueing theory in which emergency vehicle (fire trucks, ambulance etc.) is present. The researchers analyzed the traffic flow on a single road in the presence of emergency vehicle using three different queueing models such as M/M/1, M/G/1 and G/G/1. At the end of the research the simulation results illustrated that the emergency vehicle on the road had less effect on the travel time and among all the three queueing models, G/G/1 showed the best result with low variance achieving the lowest traveling time. However, the research conducted only considered reducing the travel time only in the presence of emergency vehicles where different inter-arrival and service times are considered to be independent which is not a real case scenario. Besides, reducing travel time in one road does not necessarily mean it does same for the other road as roads are connected in different manner. On the other hand, the approach we are following will consider a network of roads to reduce overall waiting time of a vehicle. According to (Wang, Yifan and Kim, Daniel and Kim, Seong-Hee and Lee, Haengju) [6] a futuristic imaginary scenario was considered where there will exist a special lane in a segment of a highway. Vehicles are categorized in different classes; vehicles of each class have an average number of passengers and uses a particular amount of space in the lane. Vehicles which wish to use the special lane have to send access request ahead of time to be able to use the lane, based on the traffic situation at that particular requested time for usage, the access control may accept or reject the special lane use request. The primary goal of the proposed system is to optimize usage of the lane space by maximizing the usage of limited resources while maximizing the throughput of the passengers in the long-run. The proposed model uses a multi-class M/G/C/C state dependent queueing model for a specific allocation of vehicle where vehicles of all classes arrive as independent Poisson arrival rates and there are no priorities. The research addresses both static and dynamic allocation of the given problem to reach the optimal usage of the lane at a given point of time. Even though the research formulates a quite interesting problem formulation, set of solutions, calculating and statistical demonstration of the numerical results. However, the futuristic scenario which was considered for this research doesn't really provide a solution to the current traffic congestion problem within the existing

traffic network that is being faced worldwide. Moreover, urban traffic congestion within complex road networks which exists within city limits has caused more stumbling block than highway traffic around the globe. The futuristic scenario considered in this research does not seem discernible. According to (Huibo Bi, Wen-Long Shang, Yanyan Chen, Kezhi Wang, Qing Yu and Yi Sui) [7] this research was conducted to reduce traffic congestion caused by fuel vehicle and electric vehicle using a mobile application which provides optimal route and incentive to take these optimal routes. The research suggested that drivers will carry a cellular device which will collect the road network data using the Geographical Information System and their position. This data will be sent to the cloud to be converted into a graph representation which will be later used to calculate the traffic intensities of nodes and edges. After that the gradient descent algorithm will calculate the optimal flow ratio at the nodes which represents the road interactions. With the following data, the RNN will calculate the optimal routes for the user. The user will also be given tasks with incentive to follow the optimal routes to maximize acceleration and minimize deceleration in the whole network. Their solution revolves around controlling the arrival rate while giving users incentive to take longer routes which may or may not work depending on the users. On the other hand, our research suggests finding the optimal service rate regardless of the arrival rate. According to (Jiri Cejka and Josef Šedivý) [8], the research was conducted for the development of a mobile application implementing queueing theory to help decision making process for finding parking spots near destination. Drivers spend a lot of time on roads searching for suitable parking spot which can result in losing valuable time and keeping more vehicles on the roads. They proposed a solution by installing illuminated panels at non-parking and parking spaces which gathers data of spot availability and using data on a queueing model ($M/M/\infty$) to help user flexibly choose the best option. With regards to potential flood risk, this proposed system can also provide information on evacuation routes. However, the root cause of traffic congestion is when demand of traffic stream overwhelms the supply of traffic streams rather than finding parking slot nearby. We tried to address the primary cause of traffic congestion which occurs in urban road networks.

Moreover, there were some methodologies other than queueing theory were used to solve the traffic congestion problem world wide. China, having the largest population in the world, faced this problem early on. Hence, various researches were conducted based on china over the past few decades. In a research based on the traffic congestion and management in China, the current urban traffic is worsened by China's major economic growth. There are always serious traffic delays and frequent accidents. The problem cannot be solved by the expansion or constructing new roads. Nevertheless, intelligent transport system (ITS) is the most useful and appropriate way to solve traffic problems worldwide. As an important component of ITS, the traffic management approach gains greatly and enhances traffic management.

According to (Cai and Yang, 2007) [9], the research can help reduce the problem of urban traffic in China by using it for traffic management. In the context of a model of group decision support system for decentralized urban traffic control, the Multi-agent system (MAS) is used. The system consists of four types of agents such as segment, crossing, section and central decision agent. But traffic management is characterized by the involvement of people in traffic and the non-linear, random, vague and uncertain characteristic of urban traffic management. The inclusion of the system for multi-agent and group decision support is thus the best way to resolve the unstructured problem scientifically. By sharing information and applying complicated traffic control in an area, it can understand intelligent traffic management. The system can achieve good level optimization by reducing traffic jam, vehicle emissions, and increasing traffic management efficiency. According to (Kong et al., 2013) [10], this research acknowledges the previous research model we have discussed and successfully implementation of the idea known as Parallel Traffic Management System (PtMS) in China before. This system operated directly on the physical transportation system and acted largely as ITS (Intelligent Transportation system). PtMS consisted on five major components. The research then moves on to its major part of concern regarding implementing PtMS in one of China's major cities called Qindao. However, Qindao's implementation of PtMS was different from previous classical ones, as the Qindao's ITS was different from other cities which consists of one center, three major platforms and eight subsystems. So, the researches proposed a new improvement and upgrade to the present existing PtMS system to provide unique control and management support which will make the PtMS more versatile, with improved compatibility, so that it can be applied in more scenarios. They designed a framework where the newly designed PtMS works in cooperation with ITS of Qindao where ITS executes the control management operations in physical transportation system and PtMS provides crucial parallel traffic decision making support to ITS by gathering traffic data from it. A similar kind of problem was addressed for Taiwan, where the gap between traffic control system and information and communication technologies prevents traffic control systems from benefiting from the advantages of information and communication technologies. According to (Lin et al., 2010) [11], the research paper introduces a novel traffic control system framework, the Mobile Intelligent Traffic Control System (MITCS), designed for Taiwan for the next generation. The proposed solution was to develop a non-intrusive multi-functional traffic controlling system which will be integrated with various micro-mechanical and electronic technologies, image processing and solar power module. The proposed smart traffic management system also aimed to be a cost-effective mobile system which will be using image processing algorithms to detect vehicles and utilize the artificial intelligence technologies to adapt to real-time traffic dynamics and adapt to the continuous changing traffic situation. The research also sees an experimental setup

and application of the proposed system where a virtual traffic setup was built which was consisted of Virtual Traffic Police (VTP) and Traffic Control Integration Module (TCIM). The system was expected to be highly cost efficient and self-organized by the researchers. In a recent research, the traffic congestion problem was addressed and describes of the ineffectiveness of the hard-coded traditional traffic management system which independently switches signal regardless of the current situation. According to (Kanungo, Sharma and Singla, 2014) [12], the research was conducted to solve the problem through video and image processing. The proposed solution would require real time live feed obtained from surveillance camera feed from important traffic junctions. The feed camera will be placed on top of the signals in 4 sides of the junction considering the junction as a four-way point. A server will be placed centrally which will be able to receive and process the surveillance camera data from various junction. The real time video data will be recorded in 30 fps. Upon receiving the real time video data, the researchers also proposed an algorithm which through which and using image, video processing the server will be able to measure the density of the vehicles in the frames in real time. Upon measuring the density of vehicles in all four sides, the system will also give dynamic and current situation-based traffic signal decisions which will eventually lead to dynamic traffic management. The implementation of the proposed system will ensure the lessen of waiting time in traffic signals especially during rush and peak hours

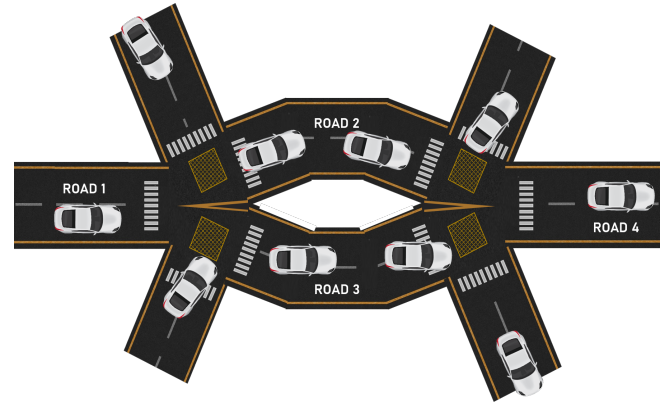

FIGURE 1: Four-way Traffic Representation

III. SYSTEM MODEL

A. ROAD TRAFFIC MODEL

As we are trying to solve the traffic problems through Jackson queueing Network and Optimization theory, it is best if we get the intuition from real life example. In figure 1, we can see there are mainly four roads where Road 1 and Road 4 are connected to both Road 2 and Road 3. We can also see that Road 2 and 3 are separately connected to some other roads apart from Road 1 and 4 where those roads can have external vehicle entries or can move to other roads apart from Road 1 and 4. In the given figure below every road has a traffic system with different operating time and service time. Moreover, vehicles can choose to move from one road to another of the other connected roads. So, the amount of cars Road 1 has can get split between Road 2 and Road 3 and any other road. Similar rule apply for all other roads in this network. So basically if a car tries to move to another road or destination, one or more lines of car has to wait in situations like this. We try to optimize these situation by reducing the amount of time a car has to wait in the network.

B. QUEUEING NETWORK MODEL

Using the intuition of figure 1, we can consider each road as a queue. Each queue is connected to another queue, creating a queueing network as a whole. Our main focus will be reducing overall waiting time in the network so that a customer has to spent less time in the network. As we mentioned earlier,

moving to another queue might create waiting time in other queues in a network if they are connected to one another. It results in longer queue line. Thus, reducing mean customer in the network can result in less waiting time. We try to optimize for each and every queue in the Jackson queueing network to find what should be done to reduce the waiting time. In Figure 2, we see a very simple transformation of roads into a queueing network which represents our previous example. Here each queue, Q1, Q2, Q3, Q4 has individual queue length, customer arrival rate and a service time rate. In this queueing network, the probability of moving to Q2 and Q3 queue from Q1 and external arrival rate determines the arrival rate of Q2 and Q3 and for queue Q4 the arrival rate would be determined by the summation of the probability of moving to Q4 from both Q2 and Q4.

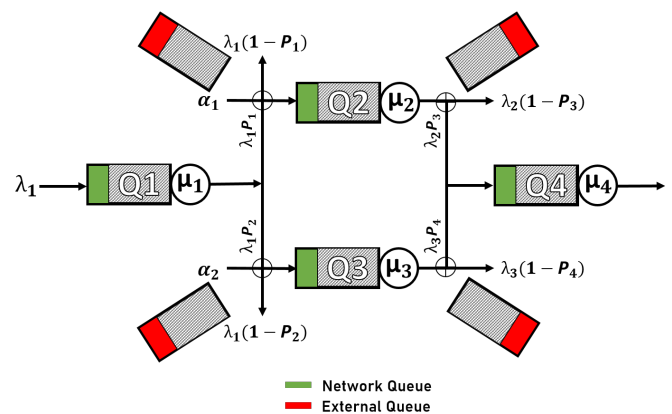

FIGURE 2: Queue Representation of Traffic Model

C. PROBLEM FORMULATION

To manage the queue length and optimize the service time of customers we need to get familiar with notions that are used to represent them. Basically, the arrival rate of customers in a queue is represented by λ which is equals to $1/[\text{expected inter-arrival time}]$ and service rate of each customer is represented by μ which is equal to $1/[\text{average service time}]$. After getting

TABLE 2: Table of Notations

Notation	Description
λ	arrival rate equals to 1/(expected inter-arrival time)
μ	service rate equals to 1/(average service time)
P	probability of moving from one queue to another
α	external arrival rate
Λ	summation of all external arrival rates
W	mean waiting time in the network
N	mean number of customer in the network
ρ	utilization of the server

service time in one queue the customer can move to another. The customer can move to one or many queues with a probability P . Again, α represents the external arrival rate of customers in the queue. Our goal here is to optimize mean waiting time in the network W . Using Little's formula [13] in Jackson network we get,

$$W = \frac{N}{\Lambda} \quad (1)$$

Here, N is the mean number of customer in the network [14] [15]

$$N = \sum_{i=1}^M \frac{\rho_i}{1 - \rho_i} \quad (2)$$

Here, ρ is the utilization of the server[14] [15].

$$\rho_i = \frac{\lambda_i}{\mu_i} \quad (3)$$

We can calculate the λ using the formula[14] [15],

$$\lambda_i = \alpha_i + \sum_{j=1}^K \lambda_j P_{ji}; \quad \text{where } 1 \leq i \leq K \quad (4)$$

Here, P_{ji} indicates the probability of moving a customer from i^{th} queue to j^{th} queue

Now, putting the value of ρ into N we get,

$$N = \sum_{i=1}^M \frac{\lambda_i}{\mu_i - \lambda_i} \quad (5)$$

Now, putting the value of N in Little's formula we get,

$$W = \frac{1}{\Lambda} \sum_{i=1}^M \frac{\lambda_i}{\mu_i - \lambda_i} \quad (6)$$

For our traffic model,

W = Mean waiting time of transports in the road

Λ = Rate of transportation entering from all external source of traffic

λ = Rate of transportation entering into a road

μ = Rate of transport moving to another road while the lane is open

As in real life we can see that, the greater number of transports is in the road, the more it is prone to traffic

congestion. So theoretically, reducing W will result in less traffic congestion. Thus, we want to minimize W .

$$\begin{aligned} & \underset{\mu}{\text{minimize}} && \frac{1}{\Lambda} \sum_{i=1}^M \frac{\lambda_i}{\mu_i - \lambda_i} \\ & \text{subject to} && \Lambda, \lambda_i, \mu_i > 0, \\ & && \Lambda, \lambda_i, \mu_i \neq \pm\infty, \\ & && \mu_i \neq \lambda_i \end{aligned} \quad (7)$$

Here, if $\Lambda = \pm\infty$, then W will become zero which in reality is not possible as external inter arrivals time cannot be zero and if $\Lambda = 0$ the W will be undefined because it divides 1. If $\lambda = \pm\infty$ then again W will be undefined as infinite will be divided by infinite. Moreover, if $\lambda = 0$ it will result W in zero as there are infinite inter arrival time which is not possible in real life scenario. Again, if $\mu = 0$ then W will become negative also if $\mu = \pm\infty$ it will result in 0 and again if we take $\mu = \lambda$ it will be undefined which is not possible in real life.

IV. METHODOLOGY

A. SYSTEM WORKFLOW

Based on our study, we have decided to conduct our research by the following steps given below in the figure 3.

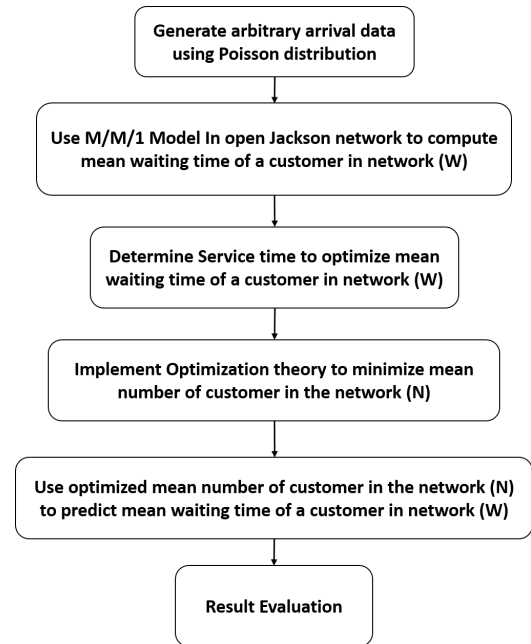

FIGURE 3: Workflow of Queuing Theory based Vehicular Traffic Management System through Jackson Network Model and Optimization

In the very beginning, we will use simulated arrival data to optimize mean waiting time of a customer by determining service time. As we are not using real time arrival data, we will use $M/M/1$ queue to implement on Jackson network. Our Jackson network will an open network as real road traffic

does not work on closed network. Then we will determine how much the service time should be provided in order to optimize our mean waiting time of a customer in the network W . After that, we will implement an optimization theory according to our function to minimize mean number of customer in the network N . Next, we will use the optimized value of N to predict the value of W . finally, we will evaluate both results to see if they match and will come to an conclusion.

We propose the queueing model to be used is Jackson queueing network along with each individual queue holding the properties $M/M/1$ queue. Here we use Kendall's notation to define various queueing model needed for our research. Kendall first described his notation in 1953 using the format of $A/S/c$ [16][17][18][19]. Here A denotes the time between arrival or arriving time in a queue, S denotes the service time distribution of the customers in the queue and c denotes the number of servers which services the customers in the queue [16] [17][18][19]. This notation has later been extended to $A/S/c/K/N/D$ where k represents the capacity or length of queue, N represents the customers to be served at a node and D represents the queueing discipline/algorithm that is used to serve the customers[16][17][18][19]. When only the first three notations are used to define a queueing model such as $M/M/1$, other symbol will represent, $K = \infty$, $N = \infty$ and D as queueing algorithm FIFO [20][16][17][18][19]. $M/M/1$ is the most fundamental queue model among the all[21]. In our traffic system the arrival of vehicles is independent of one another and the arriving time is continuous and not discrete. $M/M/1$ model consider the arriving time as continuous and use poison distribution [16][22]. The service time of our traffic system in real life is arbitrary and does not follow any specific patterns. As $M/M/1$ queue has exponential distribution for service time, this model is only used when we simulate data to test the result of service rate[23] [24]. For the network consisting a number of queues, Jackson network can be an open or closed network and moving from one queue to any other connected queues requires a probability after being served from one queue[23][24][25]. The network is open network when external arrival rates can enter the network which comes as a form of Poisson distribution and customer can also have the probability to leave the network otherwise it is only closed network[25][26]. Jackson network also uses FIFO algorithm as a service discipline[20][27]. Each queue in the system has an independent service time which means service can differ from queue to queue[14][15]. The purpose of our proposed model is to reduce the waiting time of the transports that have been waiting on the queues by optimizing service time using real time arrival data.

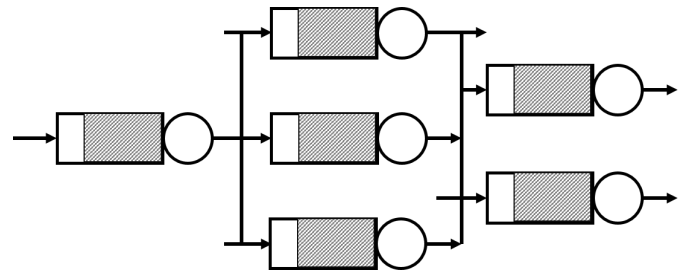

FIGURE 4: Example of an Jackson Queueing Network Model Containing $M/M/1$ Queues

Algorithm 1: Jackson Network Simulation Algorithm

input : AR1, AR2, AR3, AR4 the variables containing arrival rate of roads
EXAR containing total external arrival rate of those roads
SR1, SR2, SR3, SR4 the list containing the range of possible service rate of the roads
output: List M, containing values of SR1, SR2, SR3, SR4 list for which minimum waiting time is calculated

begin
Initialize WT = [] where it will contain the waiting time for all possible service rate;
Initialize WTC = [] where it will contain the SR1, SR2, SR3, SR4 list values of corresponding WT list value;
for each value i in SR1 list **do**
 for each value j in SR2 list **do**
 for each value k in SR3 list **do**
 for each value l in SR4 list **do**
 WTV = $1/EXAR * (AR1/(i-AR1) + AR2/(j-AR2) + AR3/(k-AR3) + AR4/(l-AR4))$;
 if WTV > 0 **then**
 Append WTV to WT;
 Append $[i, j, k, l]$ to WTC;
 end
 end
 end
 end
end
Calculate minimum value of WT using
MINV = $arg\ min(WT)$;
MINIDX \leftarrow index of MINV in WT;
M \leftarrow value of index MINIDX of WTC;
end

In this algorithm we are first taking the arrival rate of all the road/queue from the topology (AR1-AR4). Also, we are taking the external arrival rate of all the roads/queue (EXAR). Next, we are taking a list of possible service rate that can be given in each road/queue (SR1-SR4). After that, we care

using every possible combination of service rate of all roads (given in possible range) and calculating the valid (positive) waiting time. After finding all the waiting time, we are finally showing for that particular minimum waiting time what is the value of the service rates. That's how we find the minimum service rate for each road/queue that will optimize the whole server.

B. APPROXIMATION OF OPTIMIZATION

As per our system workflow, we will be using Optimization theory to minimize the mean number of customer in network

$$\begin{aligned}
N &= \sum_{i=1}^M \frac{\lambda_i}{\mu_i - \lambda_i} \\
&= \sum_{i=1}^M \frac{\lambda_i(\mu_i + \lambda_i)}{(\mu_i - \lambda_i)(\mu_i + \lambda_i)} \\
&= \sum_{i=1}^M \frac{\lambda_i\mu_i + \lambda_i^2}{\mu_i^2 - \lambda_i^2} \\
&= \sum_{i=1}^M \frac{\lambda_i\mu_i + \lambda_i^2 + \lambda_i^2}{\mu_i^2} \\
&= \sum_{i=1}^M \frac{2\lambda_i^2 + \lambda_i\mu_i}{\mu_i^2} \\
&= \sum_{i=1}^M 2\lambda^2\mu^{-2} + \lambda\mu^{-1}
\end{aligned}$$

Now, let us review the standard form of quadratic optimization [28] [29]

$$\begin{aligned}
&\text{minimize}_x \quad \frac{1}{2}x^T Px + q^T x \\
&\text{subject to} \quad Gx \preceq h, \\
&\quad \quad \quad Ax = b
\end{aligned} \tag{8}$$

$Gx \preceq h$ stands for the inequality that is taken element-wise over the vectors Gx and h and x^T indicates the transpose of x . if P is positive-semidefinite, then the above function is convex[30].

As our equation became an NP-Hard problem, we have to construct an equivalent problem to solve it using quadratic optimization. We can write the our problem in the given standard form of quadratic optimization and transformation

$$\begin{aligned}
&\text{minimize}_\mu \quad \frac{1}{2}4\lambda^2\mu^2 + \lambda\mu \\
&\text{subject to} \quad \lambda \geq 0, \\
&\quad \quad \quad \mu \geq \frac{1}{c_1}, \\
&\quad \quad \quad \mu \leq \frac{1}{c_2}
\end{aligned} \tag{9}$$

Here, we took $1/\mu^2$ and $1/\mu$ respectively as μ^2 and μ and so we changed the constraints c_1 and c_2 respectively as $\frac{1}{c_1}$

and $\frac{1}{c_2}$ for the equivalent transformation of our equation.

We can rewrite the above problem in the given matrix form

$$\begin{aligned}
&\text{minimize}_\mu \quad \frac{1}{2} \begin{bmatrix} \lambda \\ \mu \end{bmatrix}^T \begin{bmatrix} 0 & 0 \\ 0 & 4\lambda^2 \end{bmatrix} \begin{bmatrix} \lambda \\ \mu \end{bmatrix} + \begin{bmatrix} 0 \\ \lambda \end{bmatrix}^T \begin{bmatrix} \lambda \\ \mu \end{bmatrix} \\
&\text{subject to} \quad \begin{bmatrix} -1 & 0 \\ 0 & -1 \\ 0 & 1 \end{bmatrix} \begin{bmatrix} \lambda \\ \mu \end{bmatrix} \preceq \begin{bmatrix} 0 \\ \frac{-1}{c_1} \\ \frac{1}{c_2} \end{bmatrix}
\end{aligned} \tag{10}$$

Algorithm 2: Quadratic Programming based Traffic Management Algorithm

input : p, q, G, h, A, b matrices containing different coefficients and constants of the standard form of optimizing equation and it's linear inequality constraint

output: List of values for optimal solution
begin

```

initialize p = [ ] matrix where it contains
coefficients of the quadratic terms of the
optimizing equation;
initialize q = [ ] matrix where it contains
coefficients of the linear terms of the optimizing
equation;
initialize G = [ ] matrix where it contains
coefficients of the left-hand side terms of linear
inequality constraints;
initialize h = [ ] matrix where it contains
right-hand side constant(s) of the linear
inequality constraints;
initialize A = [ ] matrix where it contains
coefficients of the left-hand side terms of linear
equality constraints;
initialize b = [ ] matrix where it contains
right-hand side constant(s) of the linear equality
constraints;
calculate optimal solution via quadratic
programming using
solution = solvers.qp(p,q,G,h,A,b) where
solvers.qp() is the quadratic programming
function;
print the calculated optimal solution;

```

end

In this quadratic programming algorithm, we first need to convert the equation we are trying to optimize into the standard form. We also need to convert the inequality constraints of the optimizing equation into standard form, which is \leq form. All the terms containing variables in both the optimizing equation and it's constraints must be placed in the left hand side of the equation whereas the constants will be placed in the right hand side of the equation. Secondly, we need to construct the p,q,G,g,A,b matrices using the coefficients and constants of the standard form of the optimizing equation and it's constraints, as per stated in the

algorithm. Finally, we input all these constructed matrices to the Quadratic Programming Solver function, which will then return us the solution containing the list of optimized values for our optimizing equation.

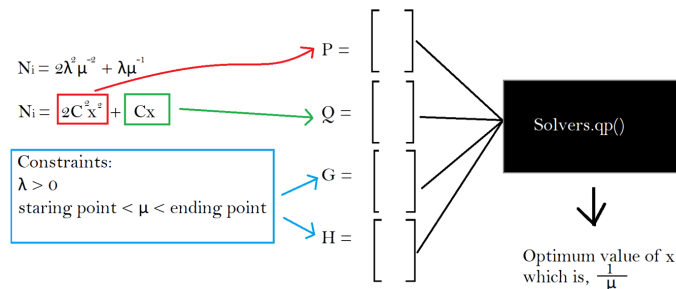

FIGURE 5: Visual Representation of Quadratic Programming based Traffic Management Algorithm

In the figure 5 after simplifying the N_i , we replaced λ with it's original value which is represented by C also we have used $\frac{1}{\mu}$ as x .

V. SIMULATION AND EXPERIMENTAL RESULTS

TABLE 3: Default Simulation Parameters

Simulation Parameters	Value	
Arrival rate (λ)	λ_1	0.55
	λ_2	0.35
	λ_3	0.32
	λ_4	0.48
Service rate (μ)	μ_1	0.90
	μ_2	0.60
	μ_3	0.60
	μ_4	0.80
External arrival rate (α)	α_1	0.15
	α_2	0.17

Considering our system model (fig:1 & fig:2), four different arrival and service rates can be seen in the table 3 above. If we go by our model, λ_1 is independent, while λ_2 and λ_3 are dependent on λ_1 . Moreover, λ_2 and λ_3 are also dependent on the external arrival rate α_1 and α_2 respectively. Lastly, λ_4 depends on λ_2 and λ_3 as well according to our model. On the other hand, services rates and external arrival rates are independent.

We have implemented the equation we have formulated for our problem scope in a code based simulation environment. We have provided a given range of values for one of the variable to observe the changes in another co-related variable, while keeping the rest of the related variables constant. We have repeated the process for multiple pair of variables to visualize and analyze the co-relation. We have also simulated the results using quadratic programming and visualized comparative results between the results we have derived from

the simulation of our formulated equation and the quadratic programming optimization used in our formulated equation and related constraints.

A. WAITING TIME IN RESPONSE TO CHANGE IN OTHER VARIABLES

In the following section, we will visualize and reflect upon the co-relation of waiting time with the other variables of our model based upon the experimental results, and gain insights upon the changes and effects in waiting time in respect to the changes in other related variables.

1) Waiting Time in Response to Change in Service Rate

In the figure 6, we can see the changes in Waiting Time (denoted in Y-axis) in response to the changes in Service Rate (denoted in X-axis) for each queues in separate curve lines. Value of λ_1 was considered and kept constant at 0.55, Value of λ_2 was considered and kept constant at 0.35, Value of λ_3 was considered and kept constant at 0.32, Value of λ_4 was considered and kept constant at 0.48.

Additionally, the value of external arrival rate for Queue 2 was considered as 0.15 and the value of external arrival rate for Queue 3 was considered as 0.17.

After keeping other variables such as arrival rate, external arrival rate constant, We can clearly see that, as we keep increasing the service rate in a specific range of values, the waiting time keeps decreasing. Value of μ_1 was ranged in between 0.575 to 0.875, Value of μ_2 was ranged in between 0.375 to 0.575, Value of μ_3 was ranged in between 0.345 to 0.595, Value of μ_4 was ranged in between 0.505 to 0.78 with a step size of 0.025.

This graph derived from our simulation shows that if there is increase in the rate of vehicles being served and leaving each queue, the average waiting time of the vehicles for each queue decreases without any exception for any of the queues. Faster the vehicles gets served in each road and leave, lesser the waiting time for vehicles staying in a road will be.

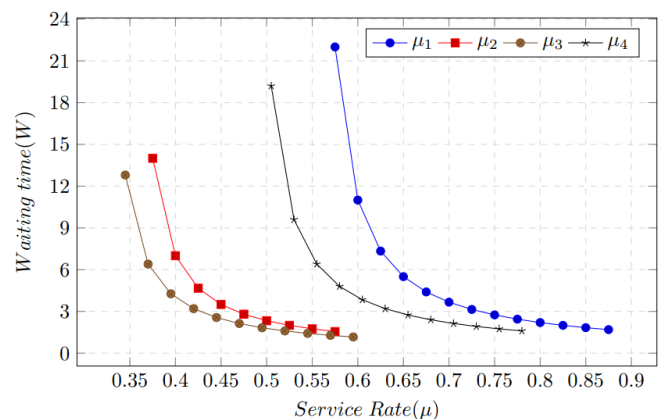

FIGURE 6: Waiting time vs Service Rate in each Queue

B. WAITING TIME IN RESPONSE TO CHANGE IN ARRIVAL RATE

In the figure 7, we can see the changes in Waiting Time (denoted in Y-axis) in response to the changes in Arrival Rate (denoted in X-axis) for each queues in separate curve lines. Value of μ_1 was considered and kept constant at 0.90, Value of μ_2 was considered and kept constant at 0.60, Value of μ_3 was considered and kept constant at 0.60, Value of μ_4 was considered and kept constant at 0.80.

Additionally, the value of external arrival rate for second queue was considered as 0.15 and the value of external arrival rate for third queue was considered as 0.17.

After keeping other variables such as service rate, external arrival rate constant, We can clearly see that, as we keep increasing the arrival rate in a specific range of values, the waiting time keeps increasing.

Value of λ_1 was ranged in between 0.425 to 0.775 with a step size of 0.025 and for each λ_1 , we calculated λ_2 such that it is equal to (external arrival rate of queue 2 + 40% of λ_1), λ_3 is equal to (external arrival rate of queue 3 + 50% of λ_1), finally $\lambda_4 = (70\% \text{ of } \lambda_2 + 80\% \text{ of } \lambda_3)$.

This graph derived from our simulation shows that if there is increase the rate of vehicles entering each queue, the average waiting time of the vehicles for each queue increases proportionally without any exception for any of the queues. Faster vehicles arriving in each road will lead to higher waiting time of the vehicles in the each of the roads will be.

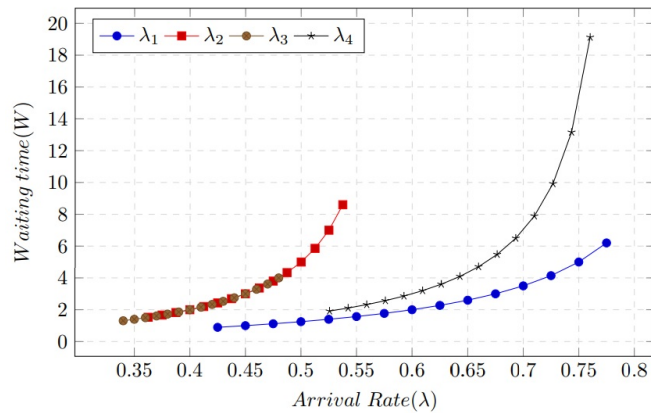

FIGURE 7: Waiting time vs Arrival Rate in each Queue

1) Waiting Time in Response to Change in External Arrival Rate

In the figure 8, we can see the changes in Waiting Time (denoted in Y-axis) in response to the changes in External Arrival Rate (denoted in X-axis) for each queues in separate curve lines. Value of μ_1 was considered and kept constant at 0.90, Value of μ_2 was considered and kept constant at 0.60, Value of μ_3 was considered and kept constant at 0.60, Value of μ_4 was considered and kept constant at 0.80.

Additionally, Value of λ_1 was considered and kept constant at 0.50, Value of λ_2 was considered the summation of 50% of λ_1 and external arrival rate of queue 2, Value

of λ_3 was considered the summation of 40% of λ_1 and external arrival rate of queue 3, Value of λ_4 was considered the summation of 70% of λ_2 and 80% of λ_3 .

After keeping other variables such as service rate, arrival rate etc. constant, We can clearly see that, as we keep increasing the external arrival rate in a specific range of values, the waiting time keeps increasing. Value of external arrival rate for both queue 2 and queue 3 was kept same for the sake of simplicity in simulation and plotting.

Value of External Arrival Rate for both Queue 2 and Queue 3 was ranged in between 0.13 to 0.28 with a step size of 0.03.

This graph derived from our simulation shows that if there is increase in the rate of vehicles entering externally from outside of the network inside second queue and third queue, the average waiting time of the vehicles for each queue increases proportionally without any exception for any of the queues. More the vehicles arriving in road network external of the network will lead to higher waiting time of the vehicles in the each of the roads will be.

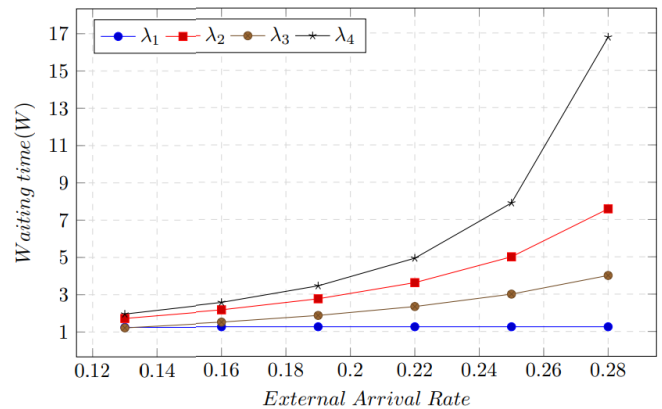

FIGURE 8: Waiting time vs External Arrival Rate for each Queue

C. UTILIZATION OF SERVERS IN RESPONSE TO CHANGE IN OTHER VARIABLES

Utilization of Servers indicate the density of vehicles are occupying each queue, meaning how much occupied and utilized each servers are. From the queueing theory, we can get to know that if the value of utilization of server, ρ is greater than 1 for a queue, then the queue becomes unstable. This means arrival rate is greater than service rate for that particular queue and the queue will face traffic congestion. In the following section, we will visualize and reflect upon the co-relation of utilization of servers with the other variables of our model based upon the experimental results, and gain insights upon the changes and effects in utilization of servers in respect to the changes in other related variables.

1) Utilization of Servers in Response to Change in Service Rate

In the figure 9, we can see the changes in Utilization of Servers (denoted in Y-axis) in response to the changes in Service Rate (denoted in X-axis) for each queues in separate curve lines. Value of λ_1 was considered and kept constant at 0.55, Value of λ_2 was considered and kept constant at 0.35, Value of λ_3 was considered and kept constant at 0.32, Value of λ_4 was considered and kept constant at 0.48.

After keeping other variables such as arrival rate, external arrival rate constant, We can clearly see that, as we keep increasing the service rate in a specific range of values, the value of utilization of servers keeps decreasing. Value of μ_1 was ranged in between 0.575 to 0.875, Value of μ_2 was ranged in between 0.375 to 0.575, Value of μ_3 was ranged in between 0.345 to 0.595, Value of μ_4 was ranged in between 0.505 to 0.78 with a step size of 0.025.

This graph derived from our simulation shows that if there is increase in the rate of vehicles being served and leaving each queue, the utilization of the servers for each queue decreases without any exception for any of the queues. Faster the vehicles gets served in each road/queue and leave, lesser the occupied and utilized each road will be.

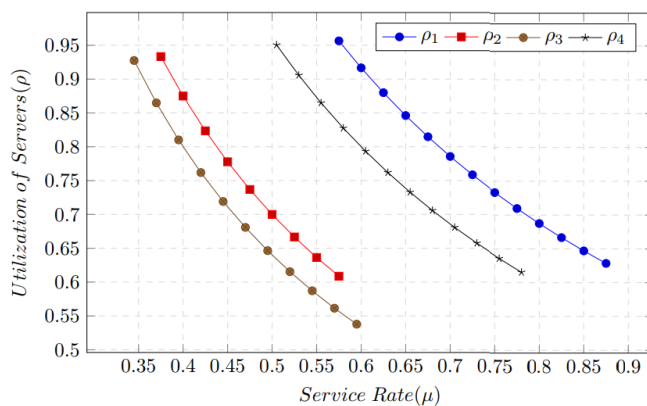

FIGURE 9: Utilization of Servers vs Service Rate in each in each Queue

2) Utilization of Servers in Response to Change in Arrival Rate

In the figure 10, we can see the changes in Utilization of Servers (denoted in Y-axis) in response to the changes in Arrival Rate (denoted in X-axis) for each queues in separate curve lines. Value of μ_1 was considered and kept constant at 0.90, Value of μ_2 was considered and kept constant at 0.60, Value of μ_3 was considered and kept constant at 0.60, Value of μ_4 was considered and kept constant at 0.80. After keeping other variables such as service rate, external arrival rate constant, We can clearly see that, as we keep increasing the service rate in a specific range of values, the value of utilization of servers keeps increasing. Value of λ_1 was ranged in between 0.425 to 0.775 with a step size of 0.025 and for each λ_1 , we calculated λ_2 such that it is equal to

(external arrival rate of queue 2 + 40% of λ_1), λ_3 is equal to (external arrival rate of queue 3 + 50% of λ_1), finally $\lambda_4 = (70\% \text{ of } \lambda_2 + 80\% \text{ of } \lambda_3)$.

This graph derived from our simulation shows that if there is increase in the rate of vehicles arriving and entering each queue, the utilization of the servers for each queue increases proportionally without any exception for any of the queues. More the rate of vehicles arriving and entering in each road/queue, more the occupied and utilized each road will be.

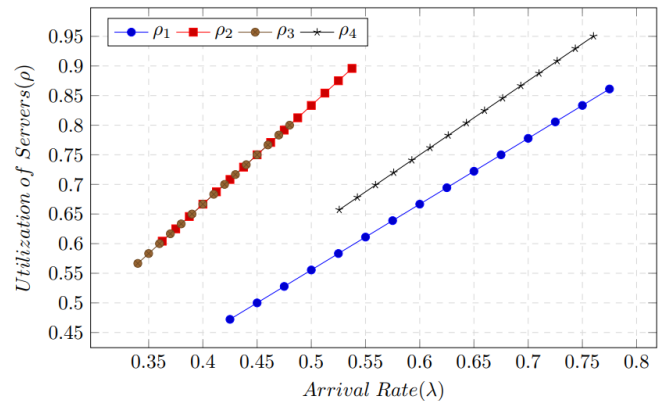

FIGURE 10: Utilization of Servers vs Arrival Rate in each in each Queue

D. TOTAL WAITING TIME IN THE NETWORK IN RESPONSE TO CHANGE IN OTHER VARIABLES

In the following section, we will visualize and reflect upon the co-relation of Total waiting time in the network with the other variables of our model based upon the experimental results, and gain insights upon the changes and effects in total waiting time in the network in respect to the changes in other related variables.

1) Total Waiting Time in the Network in Response to Change in Arrival Rate

In the figure 11, we can see the changes in Total Waiting Time (denoted in Y-axis) in response to the changes in Arrival Rate (denoted in X-axis) for each queues in the total road/queueing network in a curve line. Value of μ_1 was considered and kept constant at 0.90, Value of μ_2 was considered and kept constant at 0.60, Value of μ_3 was considered and kept constant at 0.60, Value of μ_4 was considered and kept constant at 0.80. Additionally, the value of external arrival rate for second queue was considered as 0.15 and the value of external arrival rate for third queue was considered as 0.17.

After keeping other variables such as service rate, external arrival rate constant, We can clearly see that, as we keep increasing the arrival rate in a specific range of values, the total waiting time in the network keeps increasing.

Value of λ_1 was ranged in between 0.425 to 0.775 with a step size of 0.025 and for each λ_1 , we calculated λ_2 such that

it is equal to (external arrival rate of queue 2 + 40% of λ_1), λ_3 is equal to (external arrival rate of queue 3 + 50% of λ_1), finally $\lambda_4 = (70\% \text{ of } \lambda_2 + 80\% \text{ of } \lambda_3)$.

This graph derived from our simulation shows that if there is increase in the rate of vehicles entering in the network, the average total waiting time of the vehicles for the network increases proportionally in the network. Faster vehicles arriving in the network will lead to higher total waiting time of the vehicles staying in the network will be.

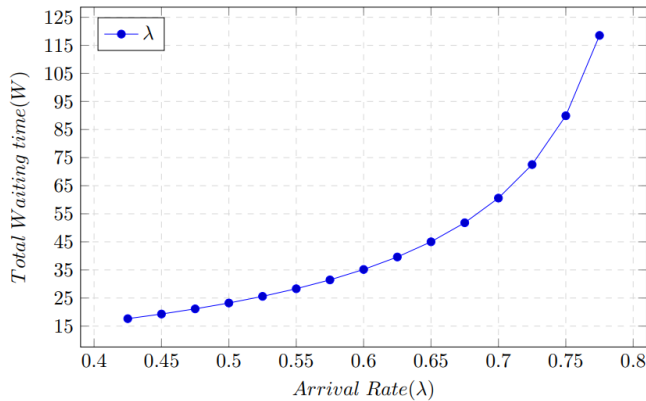

FIGURE 11: Total Waiting time vs Arrival Rate in the Network

2) Total Waiting Time in the Network in Response to Change in Total External-Arrival Rate

In the figure 12, we can see the changes in Total Waiting Time (denoted in Y-axis) in response to the changes in Total External Arrival Rate, which is the summation of external arrival rate of queue 2 and queue 3 (denoted in X-axis) for total road/queueing network in a curve line. Value of μ_1 was considered and kept constant at 0.90, Value of μ_2 was considered and kept constant at 0.60, Value of μ_3 was considered and kept constant at 0.60, Value of μ_4 was considered and kept constant at 0.80.

Additionally, Value of λ_1 was considered and kept constant at 0.50, Value of λ_2 was considered the summation of 50% of λ_1 and external arrival rate of queue 2, Value of λ_3 was considered the summation of 40% of λ_2 and external arrival rate of queue 3, Value of λ_4 was considered the summation of 70% of λ_2 and 80% of λ_3 .

After keeping other variables such as service rate, arrival rate constant, We can clearly see that, as we keep increasing the total external arrival rate in a given range of values, the total waiting time in the network keeps increasing. The increased the value of total external arrival rate λ by increasing the external arrival rates of queue 2 and queue 3 individually.

External Arrival Rate of Queue 2 and Queue 3 was kept same for the sake of simplicity in simulation and plotting, which is ranged in between 0.13 to 0.28 with a step size of 0.03.

Hence, the value of Total External Arrival Rate of the network, Λ was ranged in between 0.26 to 0.56 with a step

size of 0.06 (0.03+0.03).

This graph derived from our simulation shows that if there is increase in the summation of rate of vehicles entering externally into the network, the average total waiting time of the vehicles for the network increases proportionally in the network. Faster vehicles arriving in the network from outside of the network will lead to higher total waiting time of the vehicles staying in the network will be.

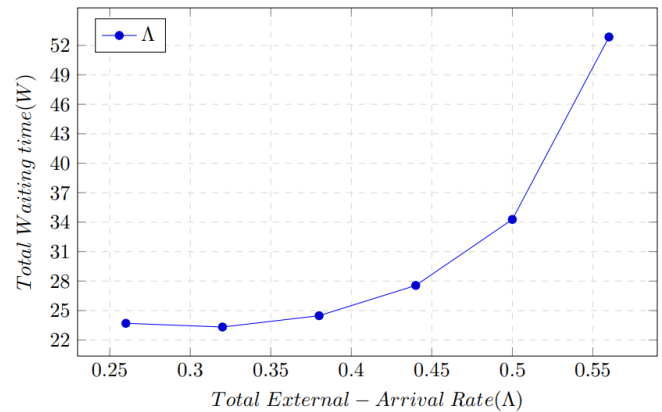

FIGURE 12: Total Waiting time vs External-Arrival Rate in the Network

E. COMPARATIVE RESULT ANALYSIS

In this section, we will gain some insights regarding the values we have calculated and derived by simulating Jackson Queueing Network Simulation Algorithm and Quadratic Programming Based Traffic Management Algorithm. Here in the table 4, we have put together the calculated values for the different variables such as service rate (μ) and utilization of server (ρ), mean waiting time in the network (W). If we compare the values for the same variable calculated in both algorithms, we can see that the difference between the results derived from the two algorithms is minimal and negligible. We have considered the value of Arrival Rates $\lambda_1 = 0.55$, $\lambda_2 = 0.35$, $\lambda_3 = 0.32$, $\lambda_4 = 0.48$. Additionally, we have considered the value of External-Arrival rates $\alpha_1 = 0.15$ and $\alpha_2 = 0.17$ for the comparison.

TABLE 4: Values derived from proposed algorithm and baseline optimization algorithm

Algorithm	Service Rate (μ)				Utilization (ρ)				Mean Waiting Time in the Network (W)	Remarks
	μ_1	μ_2	μ_3	μ_4	ρ_1	ρ_2	ρ_3	ρ_4		
Jackson Network Simulation Algorithm	0.875	0.575	0.595	0.78	0.6285 71	0.6086 96	0.5378 15	0.6153 85	18.785 936285 936273	$\mu_1 = 0.575 \text{ to } 0.875$ $\mu_2 = 0.375 \text{ to } 0.575$ $\mu_3 = 0.345 \text{ to } 0.595$ $\mu_4 = 0.505 \text{ to } 0.78$
Quadratic Programming based Traffic Management Algorithm	0.8749 999947 821058	0.5749 999798 665725	0.5949 999852 363123	0.7799 999880 807413	0.6285 714323 197935	0.6086 956734 87183	0.5378 151393 951845	0.6153 846247 883699	18.216 666375 46763	

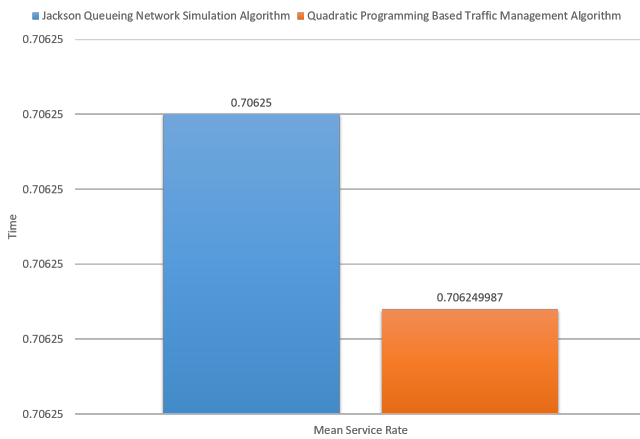

FIGURE 13: Comparison of mean service rate between proposed and baseline optimization algorithm

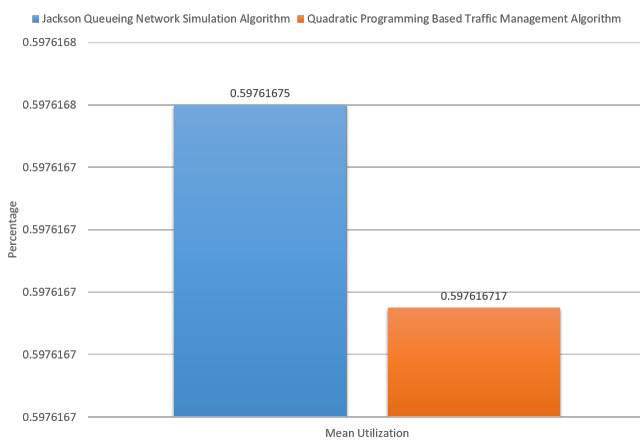

FIGURE 14: Comparison of mean utilization between proposed and baseline optimization algorithm

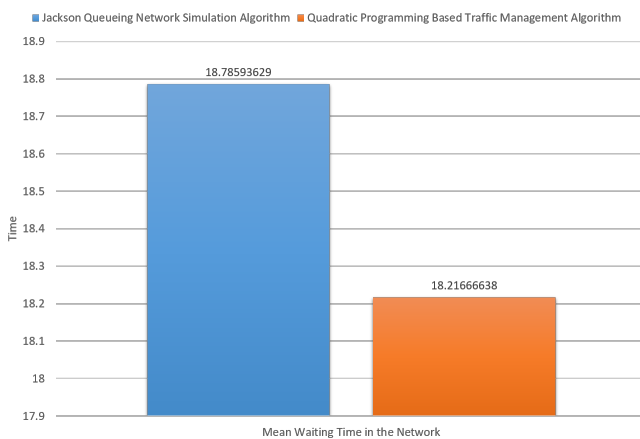

FIGURE 15: Comparison of mean waiting time in the network between proposed and baseline optimization algorithm

All the values are showing consistency after being calculated and simulated in both the algorithms, indicating the pre-

cision and correctness of our formulated queueing network model and equations based upon it.

VI. CONCLUSION

Traffic congestion has been critically hampering the lives of millions if not billions in many third- world, under-developed and developing countries around the planet. However, the developed countries are not far away from facing this problem as it is uprising in these countries as well. Both the population and the quantity of vehicles in the world are increasing day by day, so there’s no going back without facing this crisis. The only feasible solution to this situation is to deal with this problem efficiently. The traditional hard-coded traffic management and signaling system has proven ineffective and inefficient to resolve this problem. Our proposed model is going to relate a traffic system with an open Jackson Queueing network to virtually create a model of traffic network. The traffic signal decisions will be made based on data which we will provide to our model on a given range arbitrarily. Then, our proposed model will process this data using our formulated equations from our research and optimize the customer waiting time using quadratic optimization. Finally, our proposed model will provide dynamic traffic feedback and management decisions depending on current vehicle density and other co-related variables. To conclude, the proposed model focuses on implementing an autonomous and intelligent traffic management system which will reduce and optimize waiting time in traffic junctions and signals to face the challenge of this continuously expanding hurdle around the globe.

References

- [1] *World bank helps improve four large neighborhoods in dhaka city.* [Online]. Available: <https://www.worldbank.org/en/news/press-release/2019/05/29/world-bank-helps-improve-four-large-neighborhoods-in-dhaka-city>.
- [2] S. Khan, A. Khan, M. Sarker, N. Huda, M. R. Zaman, A. Nurullah, and M. Z. Rahman, “Traffic congestion in dhaka city: Suffering for city dwellers and challenges for sustainable development,” *European Journal of Social Sciences*, vol. 57, pp. 116–127, Oct. 2018.
- [3] A. A. Haider, *Traffic jam: The ugly side of dhaka’s development*, May 2018. [Online]. Available: <https://www.thedailystar.net/opinion/society/traffic-jam-the-ugly-side-dhakas-development-1575355>.
- [4] N. Guerouahane, D. Aissani, N. Farhi, and L. Bouallouche-Medjkoune, “M/g/c/c state dependent queueing model for a road traffic system of two sections in tandem,” *Computers Operations Research*, vol. 87, pp. 98–106, 2017, ISSN: 0305-0548. DOI: <https://doi.org/10.1016/j.cor.2017.05.017>. [Online]. Available: <https://www.sciencedirect.com/science/article/pii/S0305054817301375>.
- [5] S. Sumaryo, A. Halim, and K. Ramli, “Simulation and analysis of traffic flow models with emergency vehi-

- cles distortion on a single road,” in *2014 2nd International Conference on Technology, Informatics, Management, Engineering Environment*, 2014, pp. 163–168. DOI: 10.1109/TIME-E.2014.7011611.
- [6] Y. Wang, D. Kim, S.-H. Kim, and H. Lee, “Designing highway access control system using multi-class m/g/c/c state dependent queueing model and cross-entropy method,” in *2017 Winter Simulation Conference (WSC)*, 2017, pp. 1443–1454. DOI: 10.1109/WSC.2017.8247887.
- [7] H. Bi, W.-L. Shang, Y. Chen, K. Wang, Q. Yu, and Y. Sui, “Gis aided sustainable urban road management with a unifying queueing and neural network model,” *Applied Energy*, vol. 291, p. 116818, 2021, ISSN: 0306-2619. DOI: <https://doi.org/10.1016/j.apenergy.2021.116818>. [Online]. Available: <https://www.sciencedirect.com/science/article/pii/S0306261921003172>.
- [8] J. Cejka and J. Šedivý, “Discussion of operational transport analysis methods and the practical application of queueing theory to stationary traffic,” *Transportation Research Procedia*, vol. 53, pp. 196–203, 2021, International Scientific Conference "Horizons of Railway Transport 2020", ISSN: 2352-1465. DOI: <https://doi.org/10.1016/j.trpro.2021.02.026>. [Online]. Available: <https://www.sciencedirect.com/science/article/pii/S2352146521001861>.
- [9] C. Cai and Z. Yang, “Study on urban traffic management based on multi-agent system,” in *2007 International Conference on Machine Learning and Cybernetics*, vol. 1, 2007, pp. 25–29.
- [10] Q.-J. Kong, L. Li, B. Yan, S. Lin, F. Zhu, and G. Xiong, “Developing parallel control and management for urban traffic systems,” *Intelligent Systems, IEEE*, vol. 28, pp. 66–69, May 2013. DOI: 10.1109/MIS.2013.59.
- [11] L. Lin, H. Huang, J. Lin, and F. F. Young, “A new intelligent traffic control system for taiwan,” in *2009 9th International Conference on Intelligent Transport Systems Telecommunications (ITST)*, 2009, pp. 138–142.
- [12] A. Kanungo, A. Sharma, and C. Singla, “Smart traffic lights switching and traffic density calculation using video processing,” in *2014 Recent Advances in Engineering and Computational Sciences (RAECS)*, 2014, pp. 1–6.
- [13] J. Little and S. Graves, “Little’s law,” in. Jul. 2008, pp. 81–100. DOI: 10.1007/978-0-387-73699-0_5.
- [14] G. Bolc, *Queueing networks and Markov chains: modeling and performance evaluation with computer science applications*. John Wiley and Sons, 1998.
- [15] *Jackson network*, Sep. 2020. [Online]. Available: https://en.wikipedia.org/wiki/Jackson_network#:~:text=In%20queueing%20theory,%20a%20discipline,has%20a%20product-form%20solution..
- [16] *Kendall’s notation*, Sep. 2020. [Online]. Available: https://en.wikipedia.org/wiki/Kendall's_notation.
- [17] S. Robinson, *Simulation: The Practice of Model Development and Use*, ser. EBL-Schweitzer. Palgrave Macmillan, 2014, ISBN: 9781137328038. [Online]. Available: <https://books.google.com.bd/books?id=TEMdBQAAQBAJ>.
- [18] W. J. Stewart, *Probability, Markov Chains, Queues, and Simulation: The Mathematical Basis of Performance Modeling*. Princeton University Press, 2009, ISBN: 9780691140629. [Online]. Available: <http://www.jstor.org/stable/j.ctvcvm4gtc>.
- [19] J. Zhang, J. G. Dai, and B. Zwart, “Law of large number limits of limited processor-sharing queues,” *Mathematics of Operations Research*, vol. 34, no. 4, pp. 937–970, 2009. DOI: 10.1287/moor.1090.0412.
- [20] I. Adan and J. Resing, *Queueing Theory: Ivo Adan and Jacques Resing*. Eindhoven University of Technology. Department of Mathematics and Computing Science, 2001. [Online]. Available: <https://books.google.com.bd/books?id=dAViMwEACAAJ>.
- [21] J. R. Sturgul, *Mine design: examples using simulation*. Society for Mining, Metallurgy, and Exploration, 2000.
- [22] L. Kleinrock, *Queueing systems: volume 1: theory*. Wiley, 1975.
- [23] J. F. Shortle, J. M. Thompson, and D. Gross, *Fundamentals of queueing theory*. J. Wiley Sons., 2018.
- [24] B. D. Bunday, *An introduction to queueing theory*. Arnold, 1996.
- [25] F. P. Kelly, “Networks of queues,” *Advances in Applied Probability*, vol. 8, no. 2, pp. 416–432, 1976. DOI: 10.2307/1425912.
- [26] V. G. Kulkarni, *Introduction to modeling and analysis of stochastic systems*. Springer, 2011.
- [27] O. C. Ibe, *Fundamentals of Stochastic Networks*. John Wiley Sons, 2011.
- [28] *Quadratic programming*, Sep. 2020. [Online]. Available: [https://en.wikipedia.org/wiki/Quadratic_programming#:~:text=Quadratic%20programming%20\(QP\)%20is%20the,to%20linear%20constraints%20on%20these](https://en.wikipedia.org/wiki/Quadratic_programming#:~:text=Quadratic%20programming%20(QP)%20is%20the,to%20linear%20constraints%20on%20these).
- [29] J. Heider, *Quadratic programming*. [Online]. Available: https://optimization.mccormick.northwestern.edu/index.php/Quadratic_programming.
- [30] S. P. Boyd and L. Vandenberghe, *Convex optimization*. Cambridge Univ. Pr., 2011.



MD. GOLAM RABIUL ALAM (S'15–M'17) received the B.S. and M.S. degrees in computer science and engineering, and information technology, respectively, and the Ph.D. degree in computer engineering from Kyung Hee University, South Korea, in 2017. He also served as a Postdoctoral Researcher with Computer Science and Engineering Department, Kyung Hee University, South Korea, from March 2017 to February 2018. He is currently an Associate Professor with the Computer Science and Engineering Department, BRAC University, Bangladesh. His research interests include health-care informatics, mobile cloud and edge computing, ambient intelligence, and persuasive technology. He is a member of the IEEE IES, CES, CS, SPS, CIS, KIISE, and the IEEE ComSoc. He also received several Best Paper Awards in prestigious conferences.



MD. SHAZID BIN MAHBUB completed his B.Sc degree in Computer Science And Engineering from BRAC University, Dhaka, Bangladesh in the year 2021. During his undergraduate studies, he was particularly interested in programming, Machine Learning, Artificial Intelligence and Game Development.



TANJIM MUSHTARI SUMA completed her B.Sc degree in Computer Science from BRAC University, Dhaka, Bangladesh in 2020. During her time at the university, she showed great interest in Software Engineering and Management Information System. Her research interests include Artificial Intelligence, Machine Learning, Data Science, Web Development, UX and Business Intelligence Analytics.



MOHAMMAD MEHEDI HASSAN (SM'18) received his Ph.D. degree in computer engineering from Kyung Hee University, Seoul, South Korea, in February 2011. He is currently a professor with the Information Systems Department, College of Computer and Information Sciences, King Saud University, Riyadh, Saudi Arabia. He has authored and coauthored around 210+ publications including refereed IEEE/ACM/Springer/Elsevier journals conference papers, books, and book chapters.

His research interests include edge/cloud computing, the Internet of Things, cyber security, deep learning, artificial intelligence, body sensor networks, 5G networks and social network.



SK MAHTAB UDDIN received his B.Sc degree in Computer Science from BRAC University, Dhaka, Bangladesh in the year 2020. While studying he excelled in Computer Networking and Software Engineering. His research interests include Machine Learning, Cyber security, Software Testing and Web Development.



GIANCARLO FORTINO received the Ph.D. degree in computer engineering from the University of Calabria (Unical), Italy, in 2000. He is currently a Full Professor of computer engineering with the Department of Informatics, Modeling, Electronics, and Systems, Unical. He is also a Guest Professor with the Wuhan University of Technology (WUT), Wuhan, China, a High-End Expert with HUST, China, and a Senior Research Fellow with the Italian National Research Council ICAR

Institute. He is the Director of the SPEME Lab, Unical, and the Co-Chair of joint labs on the IoT established between Unical and WUT and SMU Chinese universities. He is the Cofounder and the CEO of SenSysCal S.r.l., a Unical spinoff focused on innovative IoT systems. His research interests include agent-based computing, wireless (body) sensor networks, and the Internet of Things. He is the author of over 400 papers in international journals, conferences, and books.



MD. BONY AMIN KHAN SIAM received a B.Sc. degree in Computer Science and Engineering from BRAC University, Dhaka, Bangladesh in the year 2020. During his academic career he was particularly interested in Computer Programming, Computer Networks, Database Systems, Digital Systems and Electronics. His research interests include Artificial Intelligence, Software Engineering and Internet of Things.

...