



Four-layer aerogel Cherenkov counter

K. Arisaka ^a, E. Borsato ^b, D. Boutigny ^c, A.R. Buzykaev ^d, F. Dal Corso ^b,
I. De Bonis ^c, J. Favier ^c, F. Ferroni ^e, M. Foucher ^f, S.F. Ganzhur ^d, F. Iacovella ^b,
H. Jawahery ^f, Y. Karyotakis ^c, G.M. Kolachev ^d, E.A. Kravchenko ^{d,*}, R. Lafaye ^c,
M.A. Mazzoni ^c, V.I. Mikerov ^d, M. Morandin ^b, S. Morganti ^e, A.P. Onuchin ^d,
J. Oyang ^g, G. Piredda ^e, M. Posocco ^b, R. Santacesaria ^e, M. Serra ^e, A.G. Shamov ^d,
R. Stroili ^b, V.A. Tayursky ^d, V.I. Telnov ^d, E. Torassa ^b, C. Voci ^b

^a *University of California, Los Angeles, LA, USA*

^b *Università di Padova and INFN, Sezione di Padova, Italy*

^c *LAPP CNRS / IN2P3, Annecy-le-Vieux, France*

^d *Budker Institute of Nuclear Physics, Novosibirsk, Russian Federation*

^e *Università di Roma 'La Sapienza' and INFN, Sezione di Roma 1, Rome, Italy*

^f *University of Maryland, College Park, MD, USA*

^g *California Institute of Technology, Pasadena, CA, USA*

Abstract

A 4-layer design of aerogel threshold counters using two refractive indices was suggested for the particle identification in the forward region of the BaBar detector. Three prototypes filled with the high quality aerogel produced in Novosibirsk were tested at T10 beam at CERN. Monte Carlo code was developed for the simulation of the light collection in aerogel counters. Monte Carlo results based on measured PTFE reflection coefficient and aerogel absorption and scattering lengths are in agreement with experiment. © 1998 Elsevier Science B.V. All rights reserved.

PACS: 29.40.Ka

Keywords: Aerogel Cherenkov counter; BaBar detector; Particle Identification system

1. Introduction

The main aim of the Particle Identification (PID) system in the BaBar detector is the separation of π - and K -mesons up to 4 GeV/c momentum. This

system must be able to operate in the 1.5 T magnetic field. One technique satisfying these requirements is the aerogel Cherenkov counter [1–5].

In the BaBar technical design report [6] the PID system in the forward direction is based on a threshold Cherenkov detector with two different aerogels. One of the possible designs is shown in Fig. 1.

The four-layer system consists of two super-layers comprising two counters with 1.05 and 1.008 refrac-

* Corresponding author. Tel.: +7-3832 359 933; fax: +7-3832 352 163; e-mail: kravchenko@inp.nsk.su.

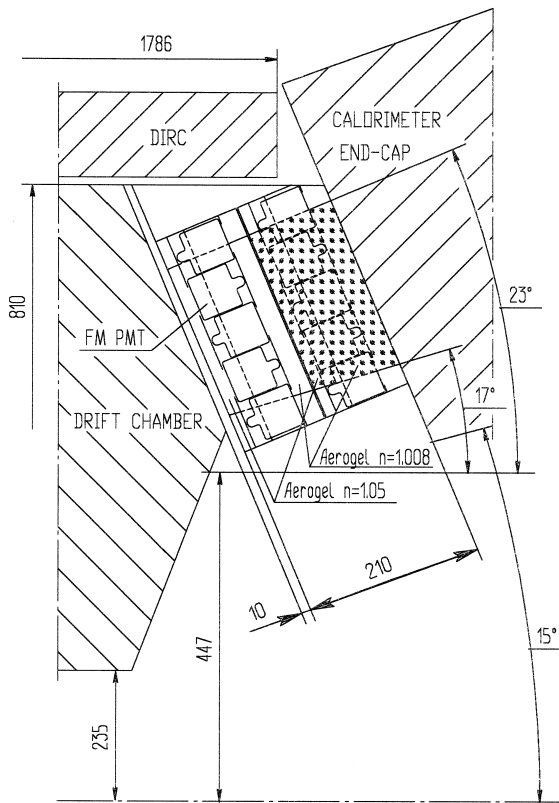

Fig. 1. The BaBar ATC detector. The 4-layer geometry.

tive indices aerogel. The second super-layer is shifted by a half of the counter size relative to the first one to avoid loss of the information when a particle

crosses the photo-tube. Each super-layer consists of 28 double counters with ‘high’ and ‘low’ refractive index aerogel. The total number of counters is 112. The photo-tubes used are 2 in. 19 stages UV glass fine-mesh Hamamatsu. The total number of photo-tubes is 280. The walls are wrapped with multi-layers of white film made from PTFE.

In order to check the feasibility of such a detector, we have built three prototypes, two with ‘high’ refractive index aerogel and one with ‘low’. They were tested during two runs at T10 test beam at CERN [7,8] together with other prototypes: two-layer prototype with Hybrid Photo-Diode readout [7,9] and two-layer prototype with fine-mesh readout [7,10].

2. Description of the beam line and apparatus

The T10 beam line at CERN with the apparatus for testing is shown in Fig. 2. T10 can provide positive or negative beam with momentum between 1 and 5 GeV/c. The beam composition was mainly pions and protons, with a small kaons and electrons contamination.

The beam line was equipped with two gas CO₂ Cherenkov counters (C1,C2) working at a pressure of 4.3 bar. The beam was defined by the coincidence of 3 scintillation counters (S1,S2,S3). The size of the beam was defined by the counter with 1 × 1 cm² dimensions.

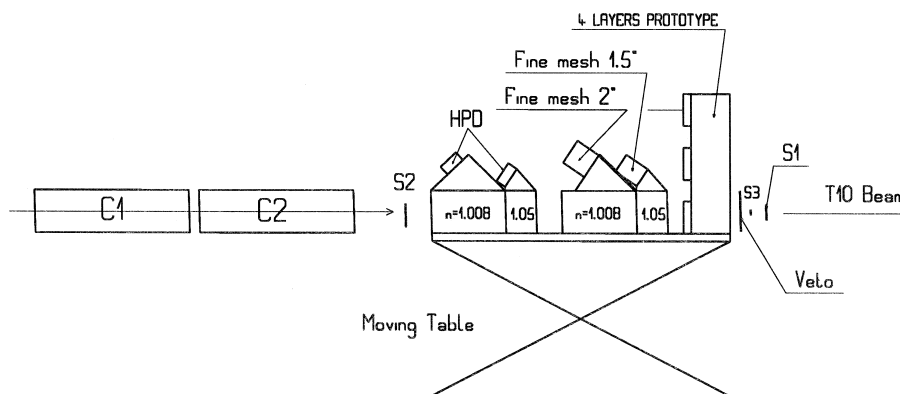

Fig. 2. Beam layout for testing of prototypes.

Three prototypes of aerogel Cherenkov counters were tested during experiments. Walls of prototypes containers were usually wrapped by three layers of 250 μm white Tetratex PTFE film. Hamamatsu R6150 PMTs were used to detect Cherenkov light.

Walls of the first ‘high’ index prototype container (Fig. 3) were wrapped by three layers of 150 μm film from Goretex plus three layers of 40 μm from Tetratex. Two PMTs were used to detect Cherenkov light. The counter was filled with the 21 mm thick aerogel with the refractive index 1.05 produced in Novosibirsk (SAN-95) [11]. The second ‘high’ index prototype (Fig. 4) was also equipped with two PMTs and SAN-95 aerogel.

The prototype with the ‘low’ index aerogel is shown in Fig. 5. Three PMTs were used for the light detection. The counter was filled with 69 mm thick

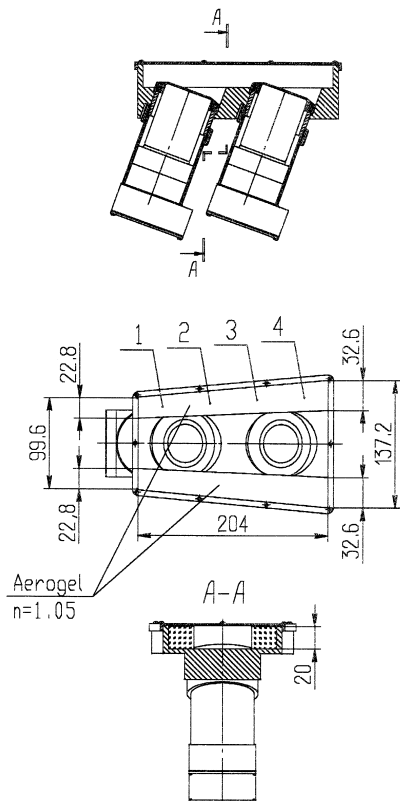

Fig. 3. The first ‘high’ index prototype.

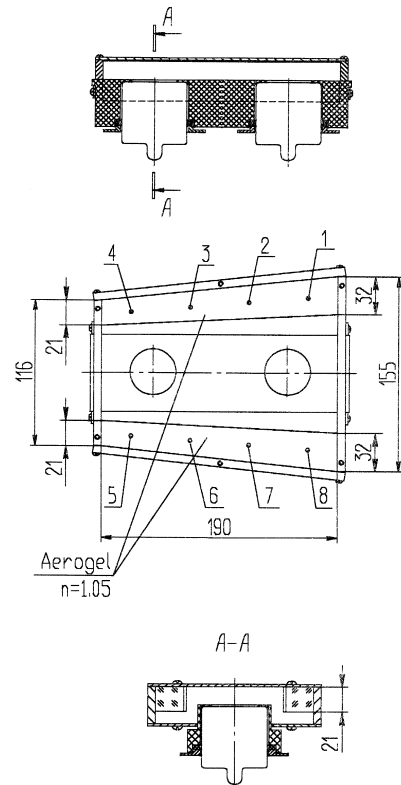

Fig. 4. The second ‘high’ index prototype.

aerogel. During beam test we tested aerogel of 1.012 refractive index produced in Novosibirsk (1.012-Nov) and 1.008 refractive index produced by Jet Propulsion Laboratory (1.008-JPL).

3. Results

3.1. Light output

To measure light signal from a relativistic particle we used 5 GeV/c pion beam. Measurements were performed in 4 points (Figs. 3–5) for each prototype. The procedure we used to determine the number of photoelectrons is described in Ref. [8]. Final results from prototypes for the sum of amplitudes from PMTs determined in the number of photoelectrons are presented in Table 1.

We have performed the direct comparison of the light output from the 1.008-JPL and 1.012-Nov aero-

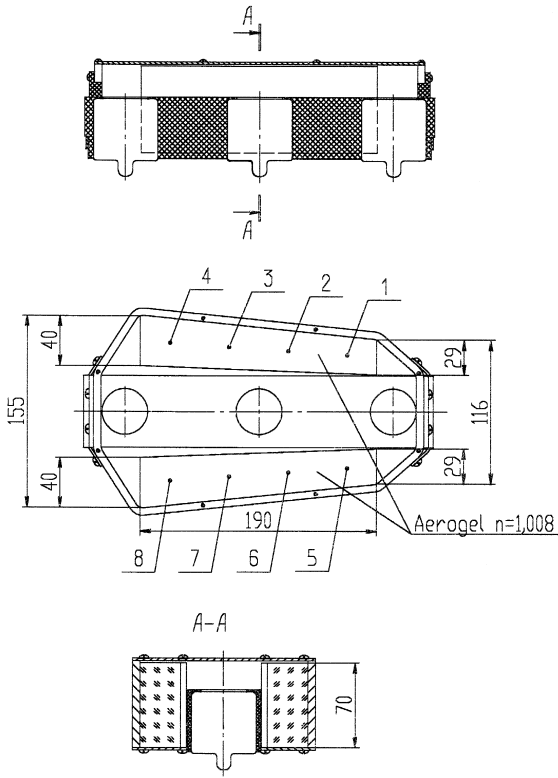

Fig. 5. The 'low' index prototype.

gels. As the amount Cherenkov light is proportional to $n - 1$, the light output from 1.008-JPL aerogel was normalized to 1.012 refractive index for the comparison of optical quality of aerogels. It appears that the light output from 'Novosibirsk' aerogel is 16% larger than from normalized JPL [8].

3.2. Response to below-threshold particles

Typical pion and proton amplitude spectra for the 'low' index prototype with $n = 1.012$ aerogel for the

Table 1
Number of photoelectrons in prototypes for four points

	1	2	3	4
'High' 1	11.2	11.6	11.1	12.4
'High' 2	9.7	9.1	10.9	11.3
'Low' $n = 1.012$	11.3	10.5		11.1

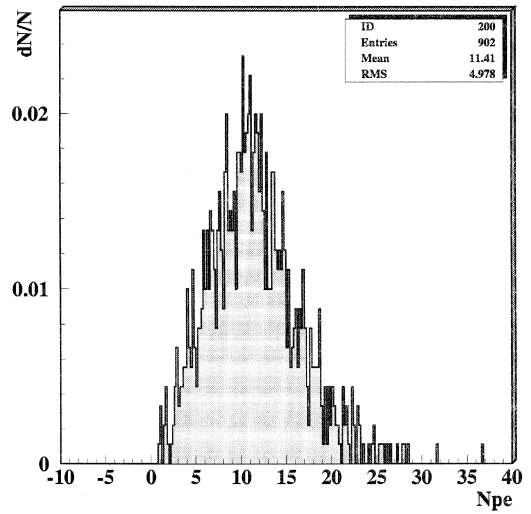

Fig. 6. Pion amplitude spectrum. 5 GeV/c beam. $n = 1.012$.

sum of 3 PMTs are presented in Fig. 6 (pions) and Fig. 7 (protons). Integration of these spectra gives the dependence of pion inefficiency and proton contamination over threshold. The point for which those two probabilities are equal is considered as a figure of merit of a detector. For the 'low' index prototype, the equality of probabilities occurs for a threshold equal to 3.3 pe, the misidentification is equal to 3.2% (Fig. 8). This corresponds to 3.7 sigma separa-

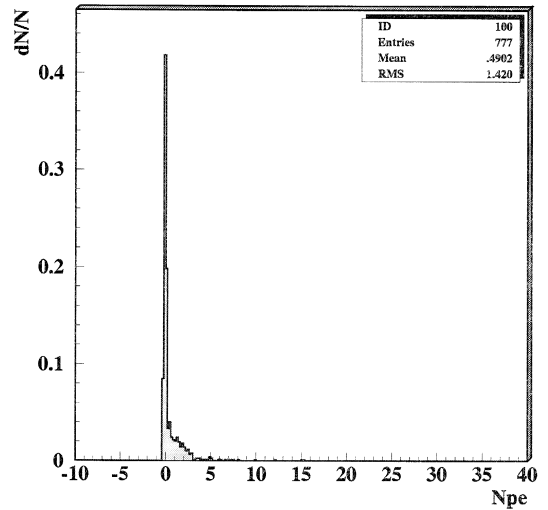

Fig. 7. Proton amplitude spectrum. 5 GeV/c beam. $n = 1.012$.

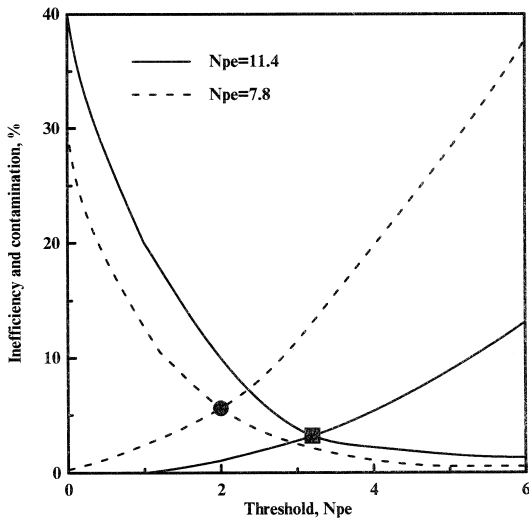

Fig. 8. Proton contamination and pion detection inefficiency for the 1.012 and 1.008 refractive index aerogels.

tion. For the first ‘high’ index prototype the equality of probabilities occurs for a threshold equal to 4.6 pe, the misidentification is equal to 4.4%-3.4 sigma separation (Fig. 9).

To determine what separation would be achieved with 1.008 refractive index aerogel with the optical quality as 1.012-Nov ($N_{pe} = 7.3$ pe) we used the

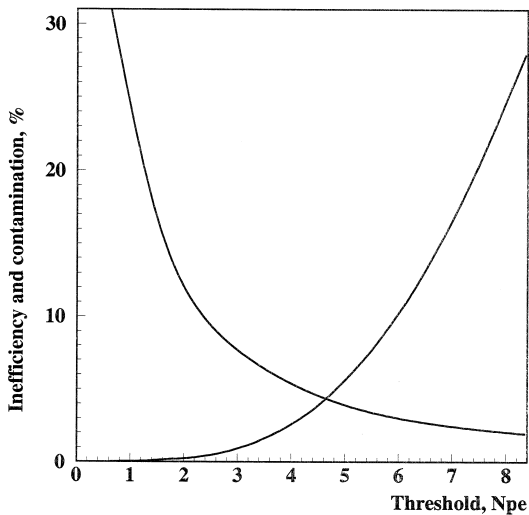

Fig. 9. Proton contamination and pion detection inefficiency for the 1.05 refractive index aerogel.

following method. We ‘switched off’ one photo-tube from our data processing. The sum of two PMTs gives $N_{pe} = 7.8$ pe. Pion inefficiency and proton contamination in this case are presented in Fig. 8. The equality of probabilities occurs for the threshold equal to 2.0 pe, the misidentification is 5.6%. This corresponds to 3.2 sigma separation.

4. Monte Carlo simulation

For the calculation of the number of photoelectrons, we used a program [2,4] simulating Rayleigh scattering and absorption inside the aerogel, Lambert angular distribution of reflected light from the walls, walls absorption, and Fresnel refraction on the boundary of two continuous media. We used absolute values of the SAN-95 aerogel absorption and scattering lengths [11] and the reflection coefficient of PTFE [12].

The results of the simulation of the second ‘high’ index prototype are presented in Fig. 10 together with the experimental data. The statistical uncertainty of results is very small. Errors are determined by uncertainty of aerogel absorption length and PTFE

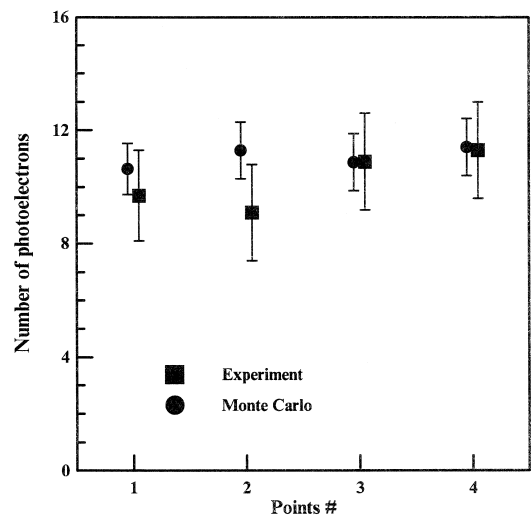

Fig. 10. The experimental results for the ‘high’ refractive index prototype and Monte Carlo prediction.

reflection coefficient. Monte Carlo results based on the measured data of the aerogel absorption, scattering lengths and PTFE reflection coefficient are in agreement with experiment.

5. Conclusions

Data confirm that four-layer design of silica aerogel threshold counters can be used as powerful and compact particle identification detector in the momentum region 0.6–4.0 GeV/c.

Monte Carlo results for the 1.05 refractive index counter based on the measured PTFE reflection coefficient, aerogel absorption and scattering lengths are in agreement with experiment.

References

- [1] G. Poelz, Nucl. Instr. Methods A 248 (1986) 118.
- [2] A.P. Onuchin et al., 5th Int. Conf. Instr. for Colliding Beams Physics, Novosibirsk, 1990 (World Scientific, 1990), p. 208.
- [3] G. Eigen, D.G. Hitlin, J. Oyang, Preprint CALT-68-1829, 1992.
- [4] A.P. Onuchin et al., Nucl. Instr. Methods A 315 (1992) 517.
- [5] T. Iijima et al., Nucl. Instr. Methods A 379 (1996) 457.
- [6] BaBar Technical Design Report, SLAC-R-95-457, SLAC, 1995.
- [7] K. Arisaka et al., Nucl. Instr. Methods A 379 (1996) 460.
- [8] K. Arisaka et al., BaBar Note # 290, SLAC, 1997.
- [9] D. Boutigny et al., IEEE Trans. Nucl. Sci. 44 (1997) 1621.
- [10] K. Arisaka et al., Nucl. Instr. Methods A 385 (1997) 74.
- [11] A.R. Buzykaev et al., Nucl. Instr. Methods A 379 (1996) 465.
- [12] A.R. Buzykaev et al., Nucl. Instr. Methods A 379 (1996) 453.