

A fairly simple mechatronic device for training human wrist motion

Rogério Sales Gonçalves¹ , Lorena Souza Furtado Brito¹,
Lucas Pinheiro Moraes¹, Giuseppe Carbone²
and Marco Ceccarelli³

Abstract

This article proposes a novel device for wrist motion rehabilitation. The proposed mechatronic architecture is based on a simple user-friendly design, which includes a mobile platform for hand support, which is operated by a single actuator. A dedicated assist-as-needed control is designed to operate the device for the required movements. The proposed control strategy is also integrated into a gaming software for stimulating the exercising by means of various interactions with patients. Experimental tests are carried out with 14 healthy subjects at the Physiotherapy Clinical Hospital of the Federal University of Uberlândia. Also, three patients with stroke have been enrolled in a pilot clinical testing. Each of the patients has been involved in four sessions per month with 15 min of assisted treatment. Results of experimental tests are analyzed in terms of improvements and amplitude gains for the flexion and extension wrist movements. Experimental results are reported as evidence for the feasibility and soundness of the proposed device as a tool to assist professionals in procedures of wrist rehabilitation.

Keywords

Service robots, medical devices, wrist motion, design, rehabilitation

Date received: 31 July 2020; accepted: 26 October 2020

Topic Area: Medical Robotics

Topic Editor: Arianna Menciassi

Associate Editor: Stefano Mazzoleni

Introduction

Motion impairments can significantly reduce the quality of life. In particular, loss of functional operation for the upper limbs can severely limit the autonomy of the affected individuals in their daily activities. Accordingly, there are several approaches for the rehabilitation of upper limbs, such as orthoses, functional electrical stimulation, physiotherapy, and, recently, robotic devices for rehabilitation. Obtaining a positive outcome of rehabilitation, in the case of neurological disorders, lays on several factors, including duration, intensity, and types of training of movements,^{1–3} as well as on the health status, attention, and effort of the patient.⁴

A key motion impairment of the upper limb refers to the mobility of the hand. The purpose of hand rehabilitation is to restore minimal functionality of a patient who has

undergone surgery or has a hand injury or illness. Manual resistance exercises for rehabilitation are important in the initial muscular tone strengthening.⁵ Rehabilitation of human hand or fingers can be a promising application for robotics.^{6,7} Gradual increases in the number of repetitions of the exercise increase the resistance to fatigue; likewise,

¹Federal University of Uberlândia, Uberlândia, Brazil

²Università della Calabria, Calabria, Italy

³University of Rome Tor Vergata, Roma, Italy

Corresponding author:

Rogério Sales Gonçalves, Federal University of Uberlândia, Avenue João Naves de Ávila, 2121 Campus Santa Mônica, Uberlândia, MG CEP 38400-902, Brazil.

Email: rsgoncalves@ufu.br



progressive increases in resistance can increase strength. However, activity or exercising should not cause pain, unusual muscle discomfort, or signs of overuse.⁵⁻⁷

Robotic devices for rehabilitation can assist in improving the increase in resistance, range of motion (ROM), and assist health professionals, as proposed, for example, in the literature.^{8,9} The possibility of using robotic devices as an efficient means of providing therapy has been the subject of research involving rehabilitation after stroke, as reported, for example, in the literature.¹⁰⁻¹⁵ Robotic devices not only have the ability to provide repetitive movements of functional training but can also provide quantitative assessments of the movement with controlled monitored actions.¹⁶ Robotic interventions for motion recovery can increase the effects of a therapy as a complement to the therapist's skills and experience, as pointed out by Gonçalves and Carvalho.¹⁷

There are several devices in the literature for rehabilitation of human wrist. Upper limb extremity function is of paramount importance to carry out various activities of daily living, in which the human wrist plays a vital role in orientation of objects.^{18,19} The wrist helps the arm in grasping and manipulating objects with proper orientation and task configuration.¹⁸ Existing robotic devices for rehabilitation mostly focus at the arm without considering the wrist. Moreover, clinical trials with devices for rehabilitation of the proximal part of the upper limb demonstrated that training the most distal segment (wrist) permits better recovery, leading to greater skill transfer to the proximal limb segment than vice versa.^{20,21,22}

One of the most successful commercial equipment for rehabilitation of the human wrist is the inmotion wrist developed at Massachusetts Institute of Technology.²³ It has three degrees of freedom allowing flexion-extension, radial-ulnar deviation, and pronation-supination movements. The device has a graphical interface, which allows interactions with a user by performing the objective motion tasks for rehabilitation within a gaming strategy, as discussed in the literature.^{24,20} Similar devices and approaches are reported in the literature.^{25,26}

Silveira et al.²⁷ presented a review of robots for rehabilitation of upper limbs. There are many orthoses, using actuators ranging from electric to pneumatic often with technical restrictions that prevent their practical use by most users. Other devices seem to be more focused at post-stroke rehabilitation users, as reported, for example, by Krebs et al.²⁸

Falzarano et al.²⁹ presented a review of solutions for the rehabilitation of human wrist, focusing on children with neuromotor problems. Conceptually, these solutions can be also adapted to adult users.

Chu and Patterson³⁰ presented a review of devices for rehabilitation of human wrist using soft robotic devices. For most of these devices, they mention that it is still required to improve the actuator design and feedback to maximize patient safety and rehabilitation outcomes.³⁰

Islam et al.³¹ reported a review of existing robotic exoskeleton solutions by highlighting the gap among laboratory prototypes and commercial devices that are available for robotic stroke rehabilitation. Upper limb robotic exoskeletons are electromechanical devices that are designed to interact with a patient for the purpose of power amplification, assistance, or substitution of motor function. These devices are usually anthropomorphic in nature and they interact with the human upper limb musculoskeletal structure on biomechanical aspects.^{31,32} The authors concluded that still significant efforts are needed in hardware design and control algorithm of existing exoskeletons. It also suggests to focus on improvements of actuation, power transmission, portability, functionality, compactness, and weight.³¹

In addition, devices need to be backdrivable to provide as much as needed torque so that patients might be taking part in motion achievement during therapy. Safety is the top priority issue and, anytime, the device should guarantee emergency. The controller should be acting like a therapist and adjust the operation on-demand or condition requirement feedback.

The cost constraints are also a key issue when considering the applications of these devices in low-income countries. Presently, rehabilitation robotic devices are priced in the range of US\$75,000–US\$350,000 prior to any additional hidden costs related to shipping, taxes, maintenance, and installation/training. This is particularly an ominous limitation as 85% of all stroke deaths occur in low- and middle-income countries.²¹

The above literature overview gives the motivation to investigate a mechatronic solution for the rehabilitation of the human wrist. Such a device should be considered as a means to assist the work of medical professionals and not to replace them. Accordingly, a novel fairly simple and low-cost device is proposed to permit easy user-oriented implementation, especially in low-income countries. The estimated cost of the proposed device is about US\$1000 in Brazil. The proposed device has one degree of freedom, and a mechanical design with few elements makes the device easily understandable to potential users. Similarly, its operation is regulated by a control system that is developed also for users, as patients and medical operators, with no technical backgrounds. This novel device can be configured to perform all individual wrist movements also at home environments.

For the purpose, we first outline the design requirements by referring to wrist kinesiology and spasticity as basis for design and operations requirements. Then, "Proposed wrist device" section describes the proposed design of our device for wrist exercising and rehabilitation. It also reports the main characteristics of its control architecture and the development of a user interface alongside a serious game strategy for allowing and stimulating interaction with the patients. Finally, clinical trials with healthy subjects and

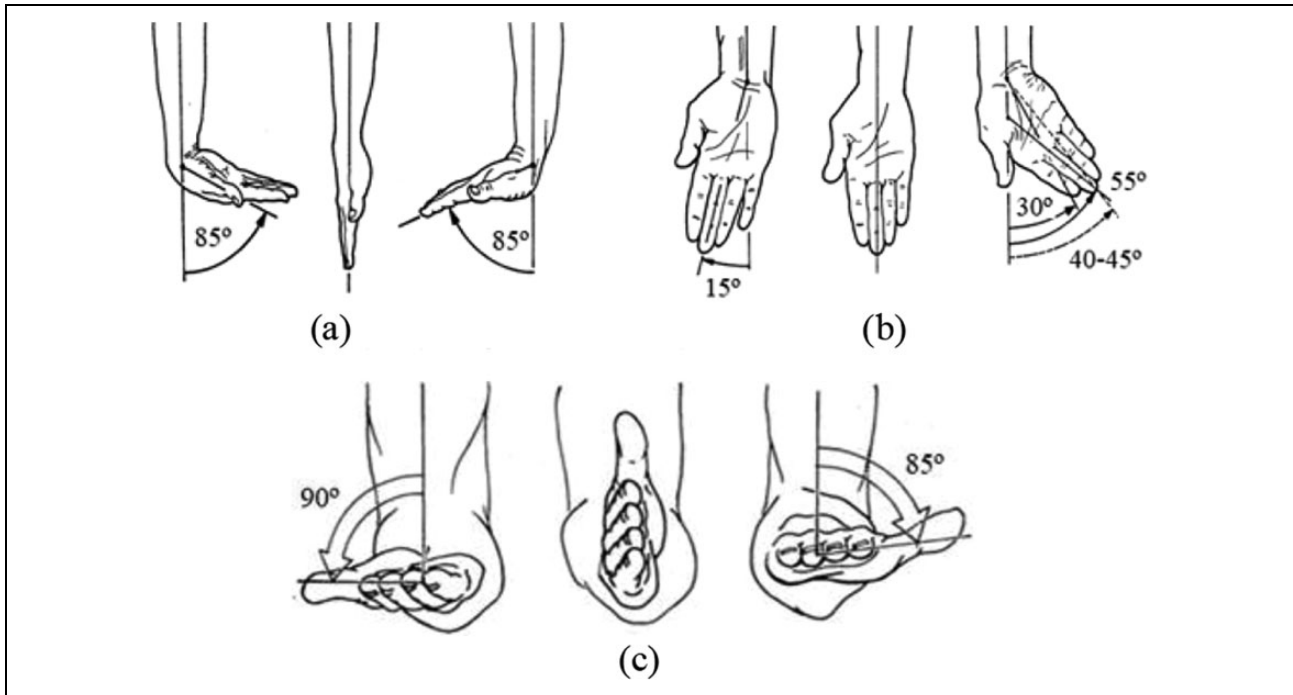

Figure 1. Motion of a hand thanks to the wrist: (a) movements of flexion–extension, (b) movements of radial deviation–ulnar deviation, and (c) pronation and supination.¹⁸

poststroke patients are presented to prove the feasibility of the device and to characterize its performance.

Wrist kinesiology and spasticity

The human wrist is the joint that connects the hand to the forearm, with two degrees of freedom, which allows the movements of flexion–extension (Figure 1(a)) and radial–ulnar deviation (Figure 1(b)). Additionally, a hand can also rotate to perform pronation and supination movements. These movements are achieved using the forearm and elbow joint (Figure 1(c)).¹⁸ The wrist usually works in conjunction with the actions of the hand. A wrist movement occurs to follow the desired movements of the hand. Thus, a wrist can be compared to a spherical joint having three rotational degrees of freedom, which are mechanically restricted by the anatomy associated with the wrist. All the movements of the wrist are performed by the muscles of the forearm.¹⁸

The spasticity is usually caused by damage to the portion of the brain or spinal cord that controls voluntary movement and causes a change in the balance of signals between the nervous system and the muscles.³³ That imbalance leads to increased activity in the muscles and negatively affects muscles and joints of the extremities. Physical and occupational therapy can help relieve stiffness, keep the muscles as flexible as possible, and prevent other problems.³³

Yoshii et al.³⁴ made a study of maximum wrist flexion and extensions torques (static position) in different forearm

positions to healthy subjects. To the pronation position of the forearm, the maximum wrist flexion was 8.3 ± 3.1 Nm and the extension was 6.5 ± 1.4 Nm. Abbas et al.,³⁵ from the analysis of the torque data of repetitive passive wrist movements, found that the mean of the torques for slow (approximately 6° s^{-1}) and moderate (approximately 120° s^{-1}) angular velocities are, respectively, 0.056 and 0.062 Nm for healthy subjects and are 0.11 and 0.15 Nm to hemiplegic patients. The hand dimensions were studied, for example, by Chandra et al.³⁶ and found the breadth mean of the hand was 102.36 ± 4.85 mm and the length mean of the hand was 187.06 ± 8.62 mm. By Plagenhoef et al.,³⁷ the average mass of a human forearm and hand is approximately 2.295% of the total body mass. The total human mass in this article is assumed as 120 kg, which includes approximately 95th percentile of male Brazilian population weight.³⁸ Accordingly, the base upper limb weight value used for designing the device is 2.75 kg.

Proposed wrist device

The design of the robot to wrist rehabilitation will consider portability and compactness (easy to move), functionality, low weight, backdrivability, assist-as-needed control, safety, learning by demonstration control, and cost effectiveness. The proposed design with the prototype in Figure 2 is composed of a hand platform and a servomotor, which has an internal proportional–integral–derivative (PID) controller that operates position, speed, and the torque applied to the platform. A mechanical flexible coupling

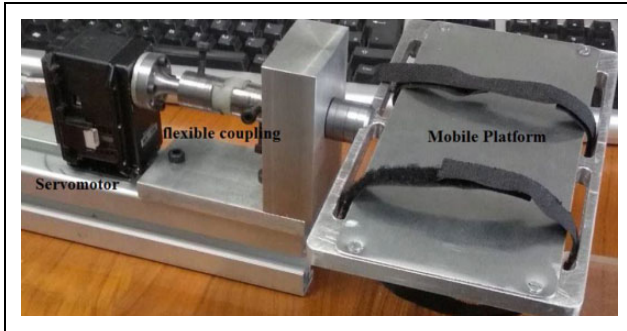

Figure 2. A built prototype of the proposed design for wrist device.

is attached to the servomotor for connecting it to the plate (hand/mobile platform) in which a patient's hand stands (Figure 2).

The force is applied by the device to the whole hand palm or vice versa, thanks to the flat surface on which the palm is located on the device. The effect of this force from the hand palm to the device platform is evaluated by a finite-element analysis (FEA), whose results are reported in Table 1.

The dimensions of the hand platform were defined as a function of the hand dimensions in Table 1. The mechanical design of the platform was made as a function of the mass of human forearm and hand. A FEA was made considering the mechanical design of the hand platform made of aluminum alloy 1060 by applying slightly oversized loading conditions to the top of the hand platform. This force has been estimated at 50 N, resulting in a minimum safety factor of 1.8 (Table 1).

A smart servomotor was selected according to the desired wrist torque,^{34,35} as reported in Table 1. The selected servomotor is a Robotis Dynamixel MX-106T, Korea.³⁹ This is a smart actuator that includes one motor, a reduction gearbox, an encoder, and a control hardware in a compact aluminum body (Figure 4). The selected servomotor can reach the full required limits of wrist movements. It can also reach the desired rehabilitation speed (up to 330° s^{-1}) and the desired torque (up to 10 Nm) for wrist rehabilitation. It has an encoder with a resolution of about 0.088° and it can give feedback measurements in terms of position, velocity, current, trajectory, temperature, and input voltage.

Table 1 summarizes the prototype numerical values based on the requirements that have been outlined in "Wrist kinesiology and spasticity" section.

The main concern when using a rehabilitation robot is safety and has an official standard IEC 80601-2-78:2019 to medical electrical equipment. When it comes to a wrist rehabilitation device, three major aspects are significantly affecting safety: operation ranges, operation modes, and operation forces/torques.¹⁰ The proposed device cannot move outside its operation ranges because this could lead

Table 1. Main characteristics of the proposed device.

Hand and prototype movements limits ($^\circ$) ¹⁸	
Flexion/extension	-85° to 85°
Radial/ulnar	-15° to 55°
Pronation/supination	-90° to 85°

Human hand³⁶ and hand platform dimensions (mm)

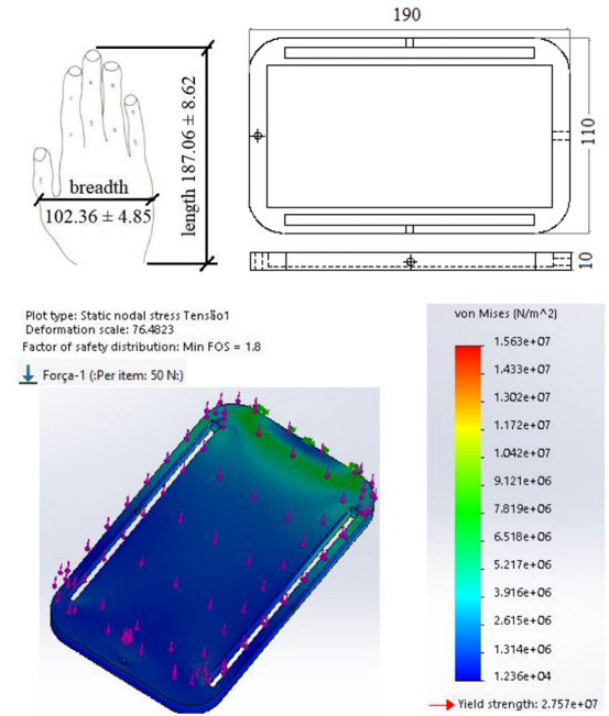

Torques wrist (Nm)^{34,35}

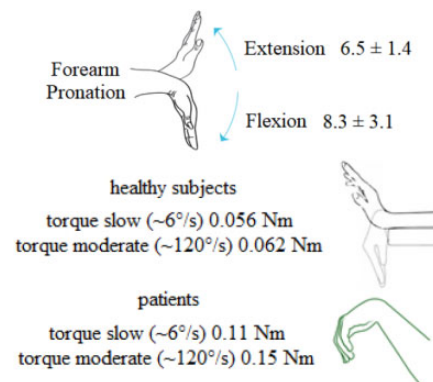

Servomotor Robotis Dynamixel MX-106T³⁹

Weight	153 g		
Dimension	$40.2 \times 65.1 \times 46 \text{ mm}^3$		
Gear ratio	225: 1		
Operation voltage (V)	10	12	14.8
Stall torque (Nm)	8.0	8.4	10.0
Stall current (A)	4.8	5.2	6.3
No load speed (r min^{-1})	41	45	55
Minimum control angle	About 0.088°		
Operating range	Actuator mode: 360°		

to undesired damage of the already affected wrist. For overcoming this safety issue, the limits of wrist movements were limited. The proposed device cannot move the hand at a greater speed than it is safe. For overcoming this safety issue, desired operation mode like speed, accelerations, and trajectories were predefined by the physiotherapist as a function of the patient’s needs and limited by software. The forces/torques applied by the proposed device cannot be greater than a safe value for the wrist and a control operation of forces/torques were implemented to follow the desired values, and the system is backdrivable. The proposed device has a safety button that stops the device when pushed.

The hand platform can be configured to be used for all individual wrist movements in Figure 1. The device needs

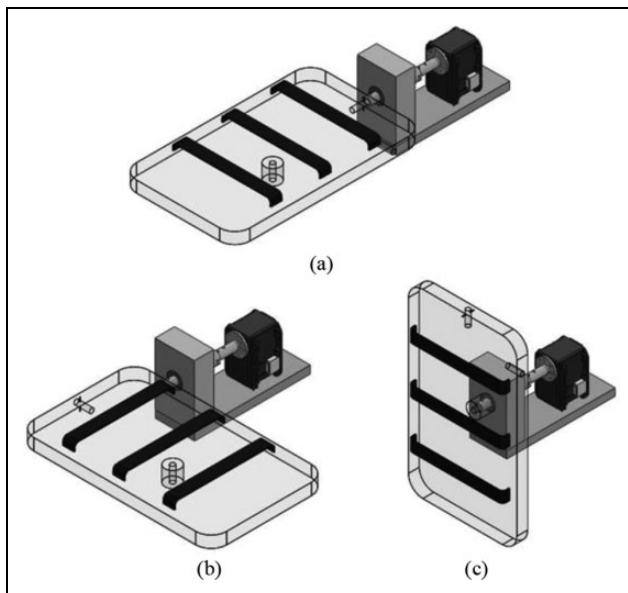

Figure 3. Hand platform configurations: (a) pronation and supination, (b) flexion–extension, and (c) movements of radial–ulnar deviation.

to be adjusted as in Figure 3, according to the desired type of rehabilitation movement. The proposed device works with an individual and simple wrist movements as function of results that are presented by Krebs et al.²⁸ and Woldag et al.⁴⁰ and it is shown that simple wrist movements can be effective in stroke rehabilitation. A high compression elastic orthopedic band is used to attach a patient hand to the hand platform. This orthopedic band provides comfort and avoids slipping of patient hand on the platform and keeps it stretched during a test.

The purpose of the device is to assist physiotherapist professionals in human wrist rehabilitation exercises and not to replace them. Thus, this structure will perform the main movements necessary for the rehabilitation through a control system that is implemented in Matlab[®] 2018, Unity 2019.3.0a5 software. The professional will fix the patient hand and will teach the movement to the device. The movements to be performed may be different for each patient, according to his/her motion needs.

The controller is made using a laptop with Intel Core i5 processor and 8Gb of RAM memory. Matlab[®] and Unity 3D[®] software are used to implement the controller of the device. The connection between the laptop and the servomotor is made using a USB to TTL converter.

Figure 4 shows the scheme of the position controller of the servomotor.

From the standard IEC 80601-2-78:2019,⁴¹ the robot for neurorehabilitation of wrist movements may use a patient cooperative control, where the goal is to maximize the patient’s efforts and only assist as much as needed, to achieve certain goals like reaching movement to a predefined target.

Figure 5 shows a drawing of the wrist robot, which constitutes a shared control system with a patient. The controllers of the patient and the wrist device interact with each other through the measurement of the interaction force in the actuated applied part. This force influences directly the movement of the physical wrist of the patient and the

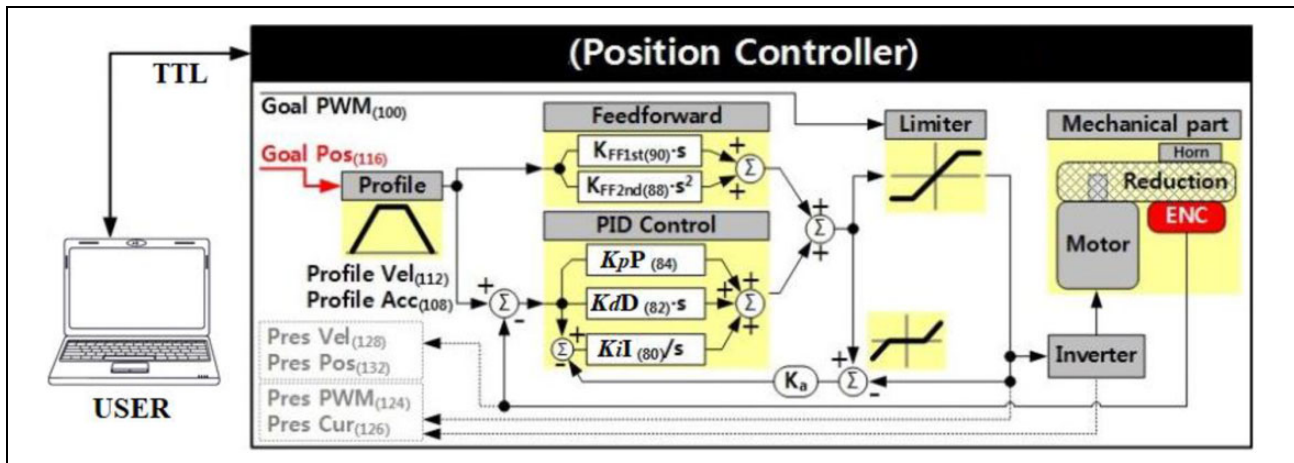

Figure 4. Scheme of position controller of the servomotor (adapted by Flores-Ortiz³⁹).

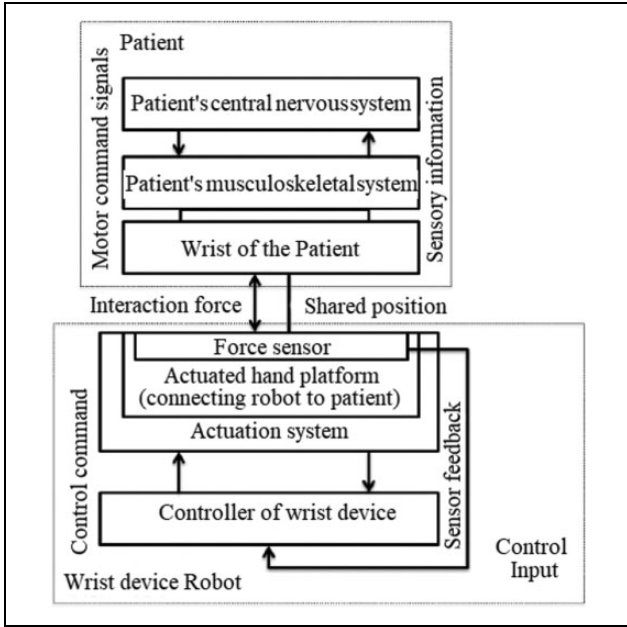

Figure 5. System drawing of the wrist device for rehabilitation that applies a patient-cooperative shared control strategy (adapted from standard IEC 80601-2-78:2019⁴¹).

physical structure of the device together with an explicit feedback signal to the wrist device. The proposed wrist device has been submitted for patenting in Italy (application number 102020000012682, May 2020).

Proposed assist-as-needed control

The nature of the tasks to be performed by the proposed device requires a flexible control, as mentioned by Alves et al.⁴² Strict control of the trajectory could, in certain cases, cause discomfort, pain, or even can hurt a patient. Therefore, an impedance controller, as proposed by Hogan,⁴³ is adopted to allow a user to deviate from the imposed trajectory obeying a certain dynamic relationship. Generally, a second-order linear dynamic relationship is used, just like a mass-damper-spring system. In the case of a rotary system, the polar moment of inertia (J_d), viscous damping (B_d), and torsional stiffness (K_p) can be designed properly as function of the controlled operation. The dynamic relationship between these variables can be expressed as

$$J_d(\ddot{\theta} - \ddot{\theta}_d) + B_d(\dot{\theta} - \dot{\theta}_d) + K_p(\theta - \theta_d) = -T_e \quad (1)$$

In equation (1), θ , $\dot{\theta}$, and $\ddot{\theta}$ are the current angular position, speed, and acceleration of the servomotor, respectively; θ_d , $\dot{\theta}_d$, and $\ddot{\theta}_d$ are the desired angular position, speed, and acceleration, respectively; and T_e is the applied external torque by the patient to the device.

From equation (1), it is possible to obtain the acceleration that the system must develop to get the desired

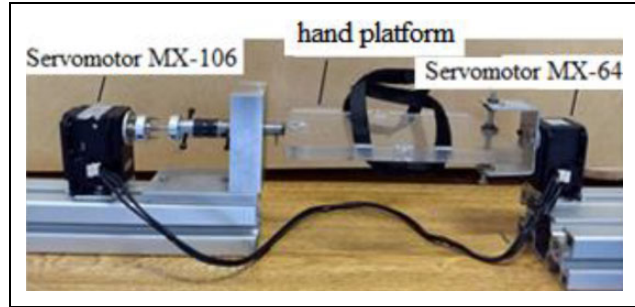

Figure 6. Laboratory prototype setup with two servomotors.

behavior. The controller set point, $\ddot{\theta}_r$, is the angular acceleration given by

$$\ddot{\theta}_r = \ddot{\theta}_d - J_d^{-1} [B_d(\dot{\theta} - \dot{\theta}_d) + K_p(\theta - \theta_d) + T_e] \quad (2)$$

The motor used to perform the rotary movement of the device is a digital servomotor (model Dynamixel MX-106³⁹). This servomotor works by sending position and speed commands with a PID control algorithm. In this way, it is possible to obtain the necessary position values, save them, and reproduce them later. The internal PID control constants are configurable (Figure 4) and this allows that, through an appropriate choice of the gain constants, the servomotor provides an adequate torque for each patient who will perform the rehabilitation movement.

The values of the system stiffness and damping, proportional (K_p) and derivative (K_d) gains, respectively, are set up directly into the configuration of the PID controller, and vary from 0 to 254.³⁹ They are dimensionless gains and without a direct correspondence with any physical unit or scale.

To preliminary tests of assist-as-needed, the patient's hand will be simulated by another servomotor, model MX-64 (model Dynamixel MX-64³⁹). Figure 6 shows the device that is assembled together with the torque generating servomotor (simulating the movement of a human hand) to set the gain constants. The constants related to the integrative and derivative are maintained as zero in all preliminary tests to simplify the control and focus only on stiffness parameter.

The simulated rehabilitation movement is generated by a sine function of 0.5-Hz period with a maximum amplitude of 40° by the servomotor rotation. This reference function is used to compare the effect of the different impedance (stiffness) settings for the device. Thus, a position controller is used, as reported in Figure 4, and the device is actuated by a current (torque) that is just the one necessary to follow the trajectory. Three tests were carried out with different impedance configurations (test 1 $K_p = 12$; test 2 $K_p = 20$; test 3 $K_p = 32$).

In the simulations, a -0.4 Nm constant torque has been assumed to simulate the effect of a patient hand. It is worthy to note that this value has been set as constant to allow a proper comparison between tests. The results of

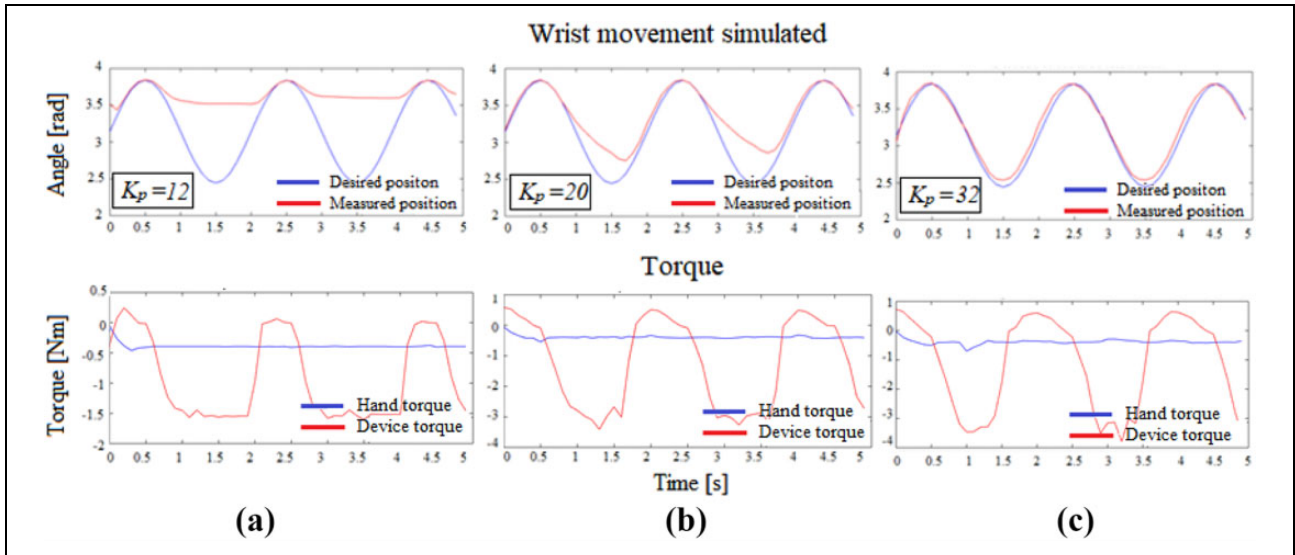

Figure 7. Wrist movement and torque simulated with stiffness parameter: (a) $K_p = 12$, (b) $K_p = 20$, and (c) $K_p = 32$.

these tests are shown in Figure 7. In Figure 7, the tracking of the trajectory presents better precision in one phase of the sine than in the other, and this asymmetry is due to the fact that the imposed reference torque acts only in one direction. Figure 7(a) shows a clear deviation when following the desired trajectory. However, the average torque exerted by the mechanism is considerably the lowest among the performed tests. This is a positive characteristic since it is desired that the device does not offer resistance when the patient has some difficulty in moving the wrist along the rehabilitation movement.

It is possible to observe in Figure 7(b) that the trajectory did not follow the desired positions as accurately as for test 3, Figure 7(c), and this shows that a greater stiffness is capable of generating a better accuracy of the proposed movement. However, this advantage comes with a high average torque throughout the movement. Therefore, it is noted that a tradeoff is needed between precision when following the path and the torque exerted by the mechanism. This can imply the choice of a variable stiffness, as used in this article, during the execution of the movement.

The results showed that the controller stiffness value significantly affects the way the device moves with the patient and that there is a clear relationship between the accuracy of the position followed and the torque exerted by the system.

Proposed serious games interaction

Serious games are defined as a mental dispute, played with a computer according to specific rules that use entertainment to promote corporate or government training, education, health, public policy, and strategic communication objectives. They involve pedagogy, transmitting knowledge or skills through activities that educate or instruct.⁴⁴

Serious rehabilitation games offer an immersive experience for motivating patients to perform exercises in an attractive and entertaining way. This also softens the effort and fatigue perception during the exercises. These games can provide an environment of competitiveness, where visual and auditory rewards, as well as scores, can be provided, also indicating the success of the patient in the rehabilitation process.⁴⁴

The motivation of developing a serious game to work together with the proposed wrist device is given by the need of stimulating the interaction similarly to a conventional training. Interest and fun during training can significantly improve the effectiveness of the treatment, as also reported by Barbosa et al.⁴⁴ The use of the proposed device with the serious game also permits a quantitative evaluation of the patient's progress, which is a valuable information for physicians and physiotherapists.

The proposed new serious game is developed for specific use with the proposed robotic device. It uses Unity 3D[®] and Matlab[®] software to communicate with the device's servomotor by reading the data sent by its sensors. Among these data, it is possible to use the current delivered to the motor, applied torque, position, and velocity. It is possible to send to the servomotor the data of the position, velocities, and torque to be reached. After exchanging the data between the servomotor and Matlab[®], a User Datagram Protocol⁴⁵ connection is used for the transmission of this data to the serious game, which is responsible for storing packets containing data on the computer's network ports.

The control update rate used was 0.1 s. The performance graph (that relates speed, efficiency, current, and torque) is presented in the literature.³⁹ The other servomotor parameters used are the default values given by the manufacturer.³⁹

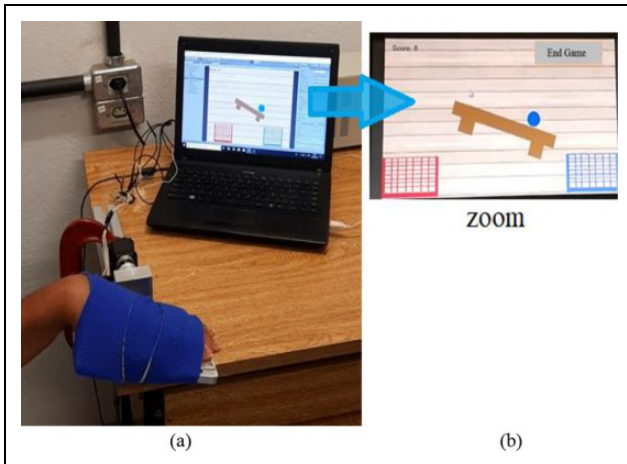

Figure 8. (a) Wooden plank movement in function of patient wrist movement and (b) sample of the game main scene.

The graphic interface of the proposed serious game is made using the game engine Unity 3D[®]. The development of the gameplay has a main concept to be of simple understanding to the patient and to have characteristics with which it can interact to establish proximity between both. The rationale for this is that once a patient is in some form of disability it is necessary to gain their attention and interest in the treatment while rehabilitation motions can be boring and unattractive as generating discomfort.^{46,47} Thus, a serious game Basket Balls (named BB), Figure 8, was developed to focus on the flexion–extension wrist movements. A patient should rotate his/her hand. This motion is transmitted to the game, rotating a wooden board that is in the center of the screen. This movement of the board is used to direct the different colored balls to the baskets of the same color. These balls are the scoring of the game, in which, for each ball correctly placed in a basket, the patient is rewarded with a point. Although there are only one blue and one red basket, which implies the existence of only the blue and red balls, there are also special balls of green color, which give more points to the player if the ball is placed in the opposite basket correctly. In this way, the patient is stimulated both physically and cognitively.

The serious game begins with the acquisition of parameter data of a patient like the passive amplitudes of movement and initial angular position of the system (initial position of hand platform). The BB presents nonpunitive mechanics so that there are no penalties for errors within the game, just they do not award points. This is to make a patient stay more relaxed and not feeling pressure during the game. In fact, not only the game presents nonpunitive mechanics but also it has an assist-as-needed system that aims to detect whether the patient is able to continue playing. Otherwise, the game software sends commands to the servomotor so that it can help to perform the movements. Among the data sent by the game to Matlab[®] are the color of the ball currently in the game and the player's net error

amount. As the amount of errors goes up, the game software sends commands so that the robotic module executes progressive torque and speed, taking control of the game more and more dynamically, increasing the stiffness K_p . This pattern repeats itself until the fifth error, in which game software takes full control of the game, moving correctly to ensure the score (Figure 9). Thus, the control system allows an understanding of whether the patient is playing really and having difficulties or if he/she is not trying to play.

This proposed assist-as-needed controller is also a simple way to verify the effort of the patient and help only if necessary. The proposed game integrates the higher capacity of calculus from Matlab[®] with the powerful graphical interface of the Unity providing a user-friendly environment. It is to note that the user-friendly feature is intended as both easy to use and to understand the device operation with nonperceivable time delays between the device and the virtual reality. To end a gaming session, it is necessary to click on the upper right button of the screen, as shown in Figure 8(b). This will display the patient's final score as well as the number of errors and the duration of the session. To assist the physiotherapist, the game is programmed to store each game data, together with the patient's name and session date, in a separate file for easy reference.

Experimental tests

Experimental trials have been approved by the ethics committee on human research at UFU (CAAE 00914818.5.0000.5152). The tests were made using the device in combination with the developed BB serious game. All participants gave their informed consent prior to enrolment.

The hypothesis assumed in this article is that the exercise sessions using the proposed device in combination with the game help in the process of rehabilitation with patients, who have impaired wrist movement after stroke since spasticity and problems with the ROM amplitude are frequent.³³ The investigated hypothesis is supported by the experimental results with other wrist devices that showed motor performance improvement.^{6,20,21}

Participants were divided into two groups, one with healthy subjects and the other with people with spasticity due to stroke. The purpose of the tests was to verify the functioning and validation of the developed system and device operation to healthy subjects before making tests with patients. Healthy participants were recruited from the student academic community of the Federal University of Uberlandia, being of both sexes, while the other group was composed of participants with diagnoses of stroke, who had already attended the Physiotherapy Clinic at UFU for rehabilitation purposes and had an interest in participating.

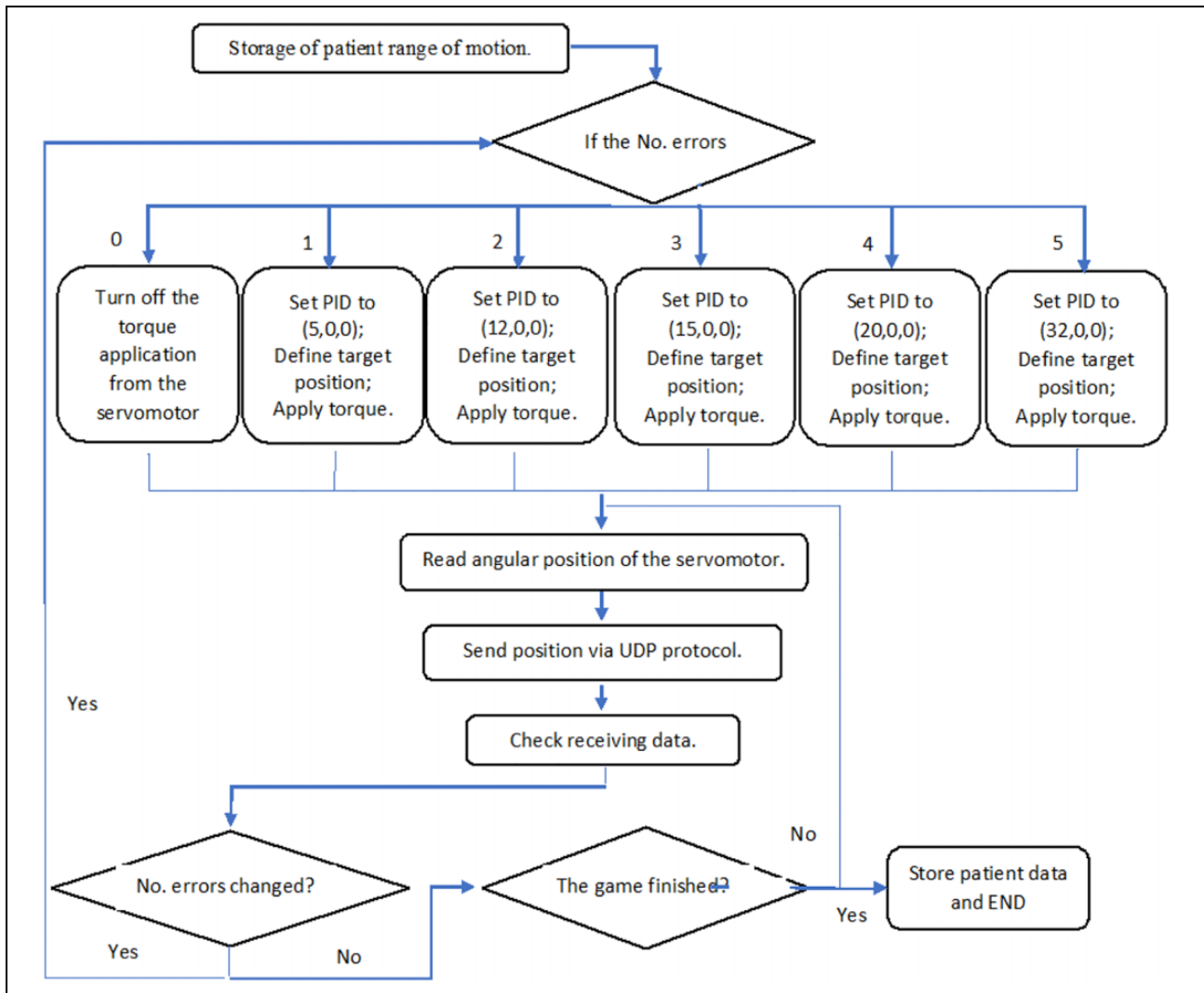

Figure 9. Flowchart of the new serious game Basket Balls developed.

Healthy subjects

A group of 14 healthy subjects (age 19.5 ± 1.57 years, height 1.71 ± 0.07 m, mass 69.04 ± 16.52 kg) without any history of musculoskeletal or neurological disorder volunteered to participate in the tests using the wrist device in a single 10-min session. They were able to evaluate together the functioning of the device and the BB game.

The tests consisted of submitting the participants to perform flexion–extension movements of the wrist with the device shown in Figures 2 and 8 playing the BB game. The movements performed are not harmful to healthy subjects. It has been verified by only minor participants' discomfort due to resulting from the number of repetitions and amplitude of the movements. The data were cataloged in a random and anonymous way, avoiding a risk of privacy breaches with identification of the participants. An Intrinsic Motivation Inventory (IMI) was applied to understand the motivation of the players during the session and their satisfaction.⁴⁸

Participants were asked to answer the questions as sincerely as possible on a scale of 1–7 (Likert scale), where 1 means totally disagree and 7 means totally agree, with 4 being a neutral score. Figure 10 shows the average and standard deviation results of IMI to healthy subjects.

The obtained average result for the categories interest/satisfaction, effort/importance, value/usefulness, and trust/relationship indicates the approval of the participants because the values were close to 6. The 6.1 perceived competence value shows that the participants felt competent and/or skilled when carrying out the proposed activity. The pressure/stress category is a negative predictor. It had a value of 2.9 indicating that the participants did not feel tense, anxious, or nervous when performing the exercises.

The evaluation of the game experience was carried out using the Game Engagement/Experience Questionnaire (GEQ). This questionnaire seeks to capture the player's experience based on various items, such as fun, frustration, challenge, among others. The GEQ is scored on a five-point

scale, ranging from “none at all” to “extremely,”⁴⁹ as reported in Figure 11. In the performed GEQ, the average score for “interface” was 3.7, which proved to be a point to be improved in future works.

The category “gameplay” had an average score of 4.4, with a total of 13 participants giving scores greater than or equal to 4. The game was not considered difficult or frustrating, since the appropriate categories showed averages of 1.8 and 1.6, respectively. The “fun” category showed that the game has the potential to be improved, as it had an average of 3.8. The overall score of the game was 4.2, with 12 participants considered the same “good” or “excellent.”

Summarizing the results from healthy participants, in Figures 10 and 11, the proposed device with the proposed serious game can be considered safe and simple to play and understand. Thus, the next step is to make a case of study to have experiences with stroke patients.

Patients

The tests with poststroke patients were carried out in the form of a case study with three patients in four sessions of 15 min each, one session per week. The patients signed informed consent regarding publishing their data. The patients participating in the study were two males and one female; they were between 48 and 63 years old with an average of 54 years. Patient “P1” had a hemorrhagic stroke with hemiparesis on the right side. His injury happened 5 years ago. Patients “P2” and “P3” had ischemic stroke with hemiparesis on the left and right side, respectively. The injuries occurred 6 years ago with patient “P2” and 1 year ago with patient “P3.”

Figure 8 shows the use of the device by a patient. The patient’s hand is fixed on the device using a bandage band. The patient’s arm is also immobilized close to the trunk, using the same type of bandage. This is necessary as patients might try to use their shoulder to help the movement of the wrist, and compensating for difficulties they have in performing a proper movement for wrist rehabilitation. In general, a physiotherapist restrains this movement to avoid patient’s forearm compensatory movements, thus allowing a patient to focus only on the flexion/extension wrist movement.

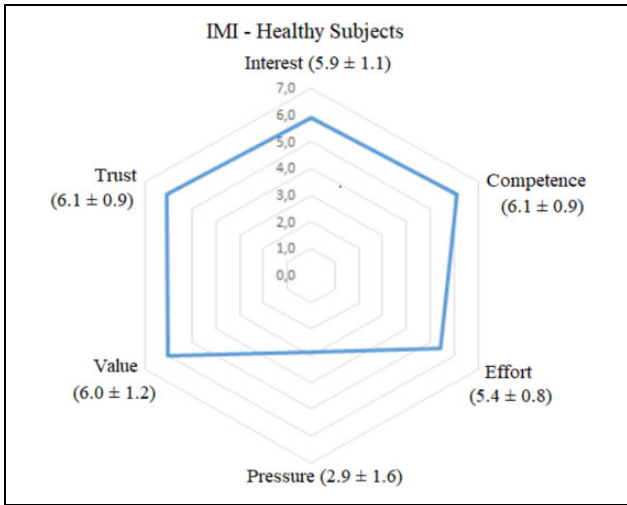

Figure 10. IMI results, average and standard deviation in each category. IMI: Intrinsic Motivation Inventory.

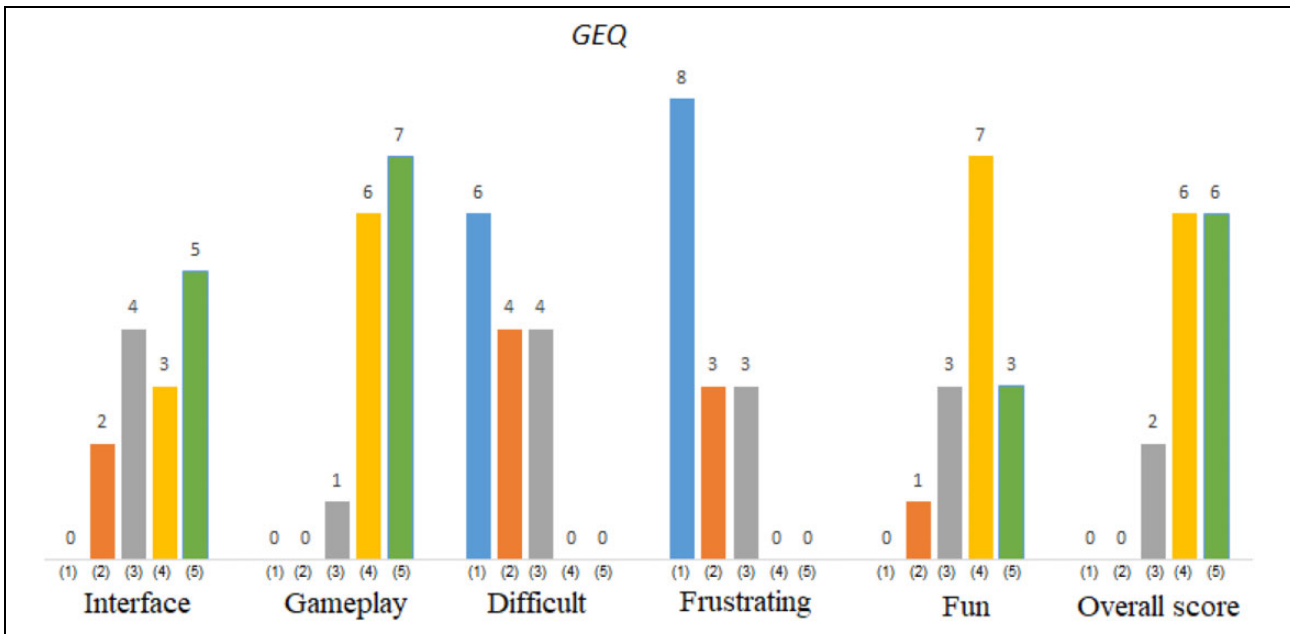

Figure 11. Results from questionnaire GEQ with 14 healthy participants (data presented as count of participants who assigned each possible grade, (1)–(5), in each category). GEQ: Game Engagement/Experience Questionnaire.

Table 2. Acquired amplitude of active extension ($^{\circ}$) of patients before and after each session.

Patient	Active extension ($^{\circ}$)							
	Section 1		Section 2		Section 3		Section 4	
	Before	After	Before	After	Before	After	Before	After
1	14	16	15	16	16	18	20	21
2	42	48	50	52	48	50	50	52
3	18	20	18	20	19	21	20	21

Table 3. Amplitude of passive extension ($^{\circ}$) of patients before and after each session.

Patient	Passive extension ($^{\circ}$)							
	Section 1		Section 2		Section 3		Section 4	
	Before	After	Before	After	Before	After	Before	After
1	58	60	60	63	61	63	65	67
2	60	68	73	75	72	75	77	80
3	57	58	58	62	60	61	61	62

Table 4. Amplitude of active flexion ($^{\circ}$) of patients before and after each session.

Patient	Active flexion ($^{\circ}$)							
	Section 1		Section 2		Section 3		Section 4	
	Before	After	Before	After	Before	After	Before	After
1	5	8	10	13	14	16	18	20
2	62	66	67	69	70	72	72	75
3	23	25	25	29	28	29	30	33

When starting the game software, it was necessary to perform a calibration of the patient's wrist and, if necessary, align correctly so that it was in a neutral position according to the height of the patient's forearm. After that, the patient was asked to perform the flexion and extension movements, with the help of the physiotherapist, so that the maximum ROM information could be measured and stored in the control system. These values, both neutral and maximum amplitudes, were used to configure the movement of the game software.

At the beginning and end of each session, the amplitudes of flexion and extension movements were measured ($^{\circ}$) using a goniometer (1° resolution) by a physiotherapist. The measurement of the movements was performed passively and actively. The values obtained are listed in Tables 2 to 5.

The robotic device also collected the maximum value of motion that each patient was able to perform. All of them were similar to the amplitudes obtained manually with the goniometer. The assist-as-needed performance is not identified by the device, but the values are collected by the

Table 5. Amplitude of passive flexion ($^{\circ}$) of patients before and after each session.

Patient	Passive flexion ($^{\circ}$)							
	Section 1		Section 2		Section 3		Section 4	
	Before	After	Before	After	Before	After	Before	After
1	82	88	85	88	88	92	91	92
2	78	80	85	89	88	90	90	90
3	75	79	77	78	78	80	79	81

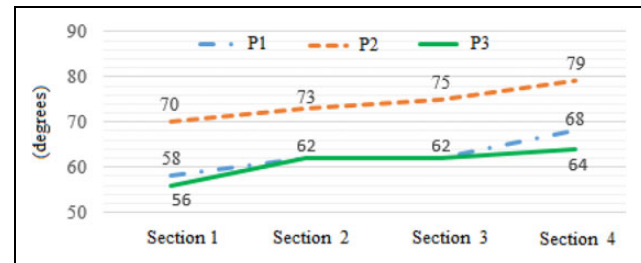
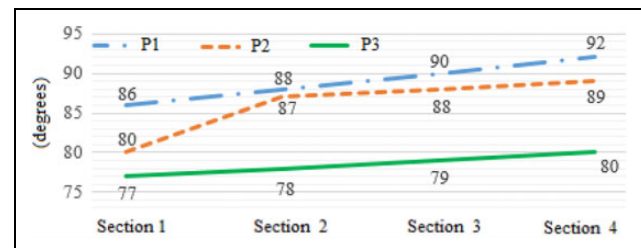
**Figure 12.** Maximum amplitude of extension ($^{\circ}$) of each patient at the end of each session obtained by the proposed device.**Figure 13.** Maximum flexion amplitude ($^{\circ}$) for each patient at the end of each session obtained by the proposed device.

device as similar to the amplitudes that are obtained manually with a goniometer. These values can be seen in Figures 12 and 13. It can be noted that at the end of the tests, all patients had an apparent gain in ROM for both extension and flexion movements, which show a positive result in relation to the feasibility of the proposed device in combination with the proposed BB serious game software. There was also an evolution in the score of each patient in the game in each session, which shows that as they were exercising and using the set of the device with the serious game software, felt more comfortable and adapted with the device functioning. These results are summarized in Figure 14.

At the end of trial tests with patients, an adapted IMI was applied to verify the experience they had when using the serious game with results that are shown in Figure 15.

The obtained average indexes close to 7.0 in the interest/satisfaction, effort/importance, value/utility, and trust/relationship categories indicate a high degree of patient approval. The 6.0 perceived competence value shows that

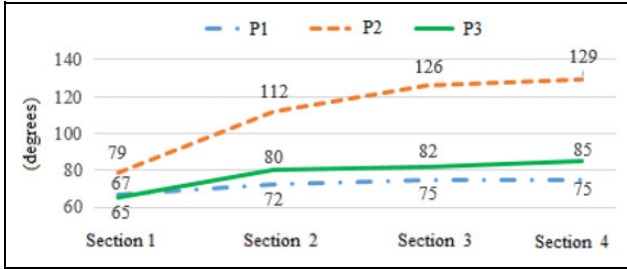

Figure 14. Score obtained in the BB serious game software by each patient during the sessions.

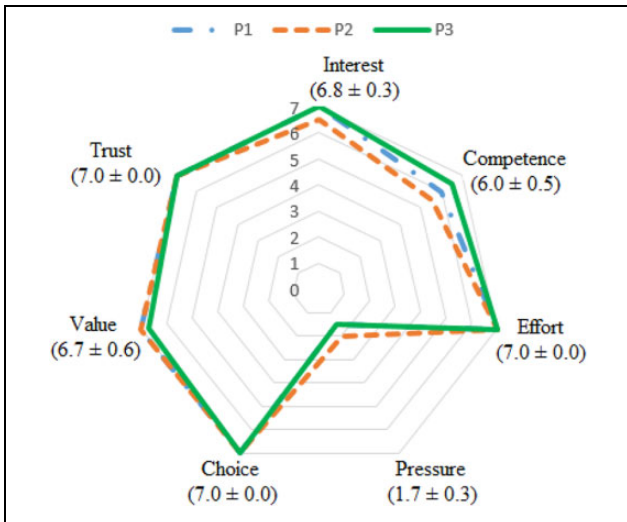

Figure 15. Intrinsic Motivation Inventory adapted for patients (average and standard deviation).

the participants felt competent and/or skilled when carrying out the proposed activity. The pressure/tension category had a value of 1.7, indicating that the patients did not feel tense, anxious, or nervous when performing the exercises but rather relaxed. The 7.0 index obtained in the choice shows that patients saw the use of the device as their own choice, not being obliged to use the proposed device.

The evaluation of the effect of robotic therapy was performed by comparing the parameters of the patients' ROM before and after the sessions. Student's *t*-test⁵⁰ was used for this analysis. The null hypothesis considered was that the use of the device did not provide a significant gain in ROM and the alternative hypothesis was gain in ROM. Statistically significant level of 0.05 was a significant gain in ROM.

The ROM is an important metric that is worth measuring because it helps understand if the devices are performing according to the anatomic ROM for each individual joint.³⁰

The results obtained in relation to the use of the proposed device showed that the model and appearance did not cause discomfort or intimidate the patient. The simple shape of the device, low cost, and low complexity were also positively assessed by patients and therapists. The development of a serious game to be used as a graphic

Table 6. ROM gain as measured by the physiotherapist and by the proposed device.

Patient	ROM gain (°) measured by physiotherapist			
	Active extension	Passive extension	Active flexion	Passive flexion
1	7	20	15	10
2	10	5	13	12
3	3	15	10	6

Patient	ROM gain (°) measured by the proposed device			
1	10	—	6	—
2	9	—	9	—
3	8	—	3	—

ROM: range of motion.

interface that is coupled with the device showed that patients felt more motivated and stimulated when performing the proposed wrist flexion and extension exercises.

Table 6 summarizes the ROM gain from the first section to the last section.

It is worth to note that there are several potential measurement error sources. For example, angles are manually measured by a physiotherapist with errors between 2° and 7° in manual procedure.⁵¹ However, this measurement procedure is well established in clinical procedures, as also indicated in the literature.⁵² Accordingly, such measurement errors can be considered mostly systematic operator errors also affecting the initial patient assessment measurements. Another error source is given by possible movements of the forearm, since the proposed device does not restrict the wrist to a fixed axis. Furthermore, the patient's arm is immobilized close to the trunk to eliminate motion compensation from other parts of the patient's body and the forearm is restraint by a physiotherapist, giving an additional potential error source.

It should be noted that in addition to the amplitude gain ROM assessment in Table 6, other functional physiotherapy scores should be used to verify the gains that are obtained by patients with the use of robotic equipment, such as functional independence measurement scales.⁵³

Although the device can be used in other configurations, only flexion and extension movements were evaluated in this article. Further experimental tests might be considered in the future for other movements within other specifically developed serious games. The proposed device can be used to different patients included the pediatric, only change the size of hand platform. The device is compact and portable to be used at home. We also made a storage with the forms and a video of the novel proposed wrist device, which is accessible at https://drive.google.com/drive/folders/1pr3DRU9MRJO1Q3jQuopipFew_UTliH5j?usp=sharing.

Conclusion

This article has reported the design and operation of a novel mechatronic device for wrist motion rehabilitation with

user-friendly, low-cost, and easy-operation features to be applied in low-income countries. Attention is addressed to its control architecture and its integration in a specifically developed serious gaming software, which stimulates patient interactions. Experimental tests have been successfully carried out at the Physiotherapy Clinical Hospital of the Federal University of Uberlândia both with healthy subjects and stroke patients in a pilot clinical testing. All participants filled an IMI form and carried out sessions of 15 min of assisted treatment. The impacts that robotic therapy brought to patients could be observed from the results obtained in relation to the range of wrist movements. In all patients participating in the case study, there was a statically significant gain in motion amplitudes. This is proving that the device can provide motor and functional rehabilitation improvements. Experimental tests focused on the flexion and extension wrist movements of all patients. However, the device can also be operated in other movements. As a suggestion for improvements toward a commercial version of the prototype, it is advisable to add an adjustable support to the forearm for minimizing compensatory movements. Accordingly, the proposed device has been submitted for patenting and it can be further investigated as a successful tool to assist professionals in procedures of wrist rehabilitation.

Acknowledgement

The authors thank Universidade Federal de Uberlândia (UFU), Fundação de Amparo à Pesquisa do Estado de Minas Gerais (FAPEMIG), Conselho Nacional de Desenvolvimento Científico e Tecnológico (CNPQ), and Coordenação de Aperfeiçoamento de Pessoal de Nível Superior (CAPES), Finance Code 001, for the partial financial support to this work. The authors thank the physiotherapists Jadiane Dionisio and Cristiane Lange that helped with the trial tests.



Declaration of conflicting interests

The author(s) declared no potential conflicts of interest with respect to the research, authorship, and/or publication of this article.

Funding

The author(s) disclosed receipt of the following financial support for the research, authorship, and/or publication of this article: This work was supported by Fundação de Amparo à Pesquisa do Estado de Minas Gerais (FAPEMIG), Conselho Nacional de Desenvolvimento Científico e Tecnológico (CNPQ), and Coordenação de Aperfeiçoamento de Pessoal de Nível Superior (CAPES), Finance Code 001.

ORCID iDs

Rogério Sales Gonçalves  <https://orcid.org/0000-0002-1378-0363>
Giuseppe Carbone  <https://orcid.org/0000-0003-0831-8358>
Marco Ceccarelli  <https://orcid.org/0000-0001-9388-4391>

References

1. Feys H, Weerdt WD, Verbeke G, et al. Early and repetitive stimulation of the arm can substantially improve the long-term outcome after stroke: a 5-year follow-up study of a randomized trial. *Stroke* 2004; 35(4): 924–929.
2. Barbosa AM, Carvalho JCM, and Gonçalves RS. Cable-driven lower limb rehabilitation robot. *J Braz Soc Mech Sci Eng* 2018; 40: 245.
3. Lisa AB, Stephanie AR-A, Timothy RE, et al. *Handbook of rehabilitation psychology*. Washington, DC: The American Psychological Association, 2019.
4. Patton J, Small SL, and Rymer WZ. Functional restoration for the stroke survivor: informing the efforts of engineers. *Top Stroke Rehabil* 2008; 15(6): 521–541.
5. Weiss S and Falkenstein N. *Hand rehabilitation*. 2nd ed. Maryland Heights: Mosby, 2004.
6. Aggogeri F, Mikolajczyk T, and O’Kane J. Robotics for rehabilitation of hand movement in stroke survivors. *Adv Rehabil Eng Robot Mechatron Dev* 2019; 11(4):1–14.
7. Carbone G, Gerding EC, Corves B, et al. Design of a two-DOFs driving mechanism for a motion-assisted finger exoskeleton. *Appl Sci* 2020; 10: 2619.
8. Gonçalves RS and Rodrigues LAO. Development of a novel parallel structure for gait rehabilitation. In: Maki KH (ed.) *Advances in computational intelligence and robotics*. 1st ed. Pennsylvania: IGI Global, 2020, pp. 42–81.
9. Loos V, der HM, Reinkensmeyer DJ, et al. Rehabilitation and health care robotics. In: Siciliano B and Khatib O (eds) *Springer handbook of robotics*. Berlin: Springer, 2016.
10. Cafolla D, Russo M, and Carbone G. Design and validation of an inherently safe cable-driven assisting device. *Int J Mech Control* 2018; 19(01): 23–32.
11. Ceccarelli M (ed). *Service robots and robotics: design and application*. Pennsylvania: IGI Global, Hershey, 2012.
12. Gonçalves RS, Carvalho JCM, Rodrigues LA, et al. Cable-driven parallel manipulator for lower limb rehabilitation. *Appl Mech Mater* 2013; 459: 535–542.
13. Hesse S, Schmidt H, Werner C, et al. Upper and lower extremity robotic devices for rehabilitation and for studying motor control. *Curr Opin Neurol* 2003; 16(6): 705–710.
14. Gonçalves RS and Krebs HI. MIT-skywalker: considerations on the design of a body weight support system. *J Neuroeng Rehabil* 2017; 14: 88.
15. Cafolla D, Russo M, and Carbone G. CUBE, a cable-driven device for limb rehabilitation. *J Bionic Eng* 2019; 16(3): 492–502.
16. Edwards DJ, Cortes M, Rykman-Peltz A, et al. Clinical improvement with intensive robot-assisted arm training in chronic stroke is unchanged by supplementary tDCS. *Restor Neurol Neurosci* 2019; 37: 167–180.
17. Gonçalves RS and Carvalho JCM. Robot modeling for physical rehabilitation. In: Ceccarelli M (ed) *Service robots and robotics: design and application*. Hershey: Engineering Science Reference (an imprint of IGI Global), 2012, pp. 1212–1232.
18. Kapandji AI. *The physiology of the joints, volume 1: upper limb*. 6th ed. Vol. 1, London: Churchill Livingstone, 2007.
19. Xu D, Zhang M, Xu H, et al. Interactive compliance control of a wrist rehabilitation device (WReD) with enhanced

- training safety. *J Healthcare Eng* 2019; 2019. DOI: 10.1155/2019/6537848.
20. Charles SK, Krebs HI, Volpe BT, et al. Wrist rehabilitation following stroke: initial clinical results. In: *9th IEEE international conference on rehabilitation robotics*, Chicago, IL, USA, 28 June–1 July 2005, pp. 13–16. IEEE.
 21. Duret C, Grosmaire A-G, and Krebs HI. Robot-assisted therapy in upper extremity hemiparesis: overview of an evidence-based approach. *Front Neurol* 2019; 10: 412.
 22. Amirabdollahian F, Ates S, Basteris A, et al. Design, development and deployment of a hand/wrist exoskeleton for home-based rehabilitation after stroke – SCRIPT project. *Robotica* 2014; 32: 1331–1346.
 23. Brackenridge J, Bradnam LV, Lennon S, et al. A review of rehabilitation devices to promote upper limb function following stroke. *Neurosci Biomed Eng* 2016; 4(1): 25–42.
 24. Durand S, Rohan CP-Y, Hamilton T, et al. Passive wrist stiffness: the influence of handedness. *JMIR Biomed Eng* 2019; 4(1): e11670.
 25. Pezent E, Rose CG, Deshpande AD, et al. Design and characterization of the OpenWrist: a robotic wrist exoskeleton for coordinated hand-wrist rehabilitation. In: *IEEE international conference on rehabilitation robotics*, London, UK, 01 July 2017, pp. 720–725. IEEE.
 26. Su YY, Yu YL, Lin CH, et al. A compact wrist rehabilitation robot with accurate force/stiffness control and misalignment adaptation. *Int J Intell Robot Appl* 2019; 3: 45–58.
 27. Silveira AT, de Souza MA, Fernandes BL, et al. From the past to the future of therapeutic orthoses for upper limbs rehabilitation. *Res Biomed Eng* 2018; 34(4): 368–380.
 28. Krebs HI, Volpe BT, Williams D, et al. Robot-aided neurorehabilitation: a robot for wrist rehabilitation. *IEEE Trans Neural Syst Rehabil Eng* 2007; 15(3): 327–335.
 29. Falzarano V, Marini F, Morasso P, et al. Devices and protocols for upper limb robot-assisted rehabilitation of children with neuromotor disorders. *Appl Sci* 2019; 9(2689): 1–22.
 30. Chu C and Patterson RM. Soft robotic devices for hand rehabilitation and assistance: a narrative review. *J Neuroeng Rehabil* 2018; 15: 9.
 31. Islam MR, Spiewak C, Rahman MH, et al. A brief review on robotic exoskeletons for upper extremity rehabilitation to find the gap between research prototype and commercial type. *Adv Robot Autom* 2017; 6(3): 1–12.
 32. Gull MA, Bai S, and Bak T. A review on design of upper limb exoskeletons. *Robotics* 2020; 9: 16.
 33. Elovic E and Brashear A. *Spasticity: diagnosis and management*. New York, NY: Demos Medical Publishing, 2010.
 34. Yoshii Y, Yuine H, and Ishii T. Measurement of wrist flexion and extension torques in different forearm positions. *Biomed Eng Online* 2015; 14: 115.
 35. Abbas O, Hiroyuki M, Kotaro T, et al. Reliability of stiffness measurement device during passive isokinetic spastic wrist movements of healthy subjects and hemiplegics. *Biocybern Biomed Eng* 2017; 37: 114–123.
 36. Chandra A, Chandna P, and Deswal S. Hand anthropometric survey of male industrial workers of Haryana state (India). *Int J Ind Syst Eng* 2011; 9(2): 163–182.
 37. Plagenhoef S, Evans FG, and Abdelnour T. Anatomical data for analyzing human motion. *Res Q Exercise Sport* 1983; 54: 169–178.
 38. Flores-Ortiz R, Malta DC, and Velasquez-Melendez G. Adult body weight trends in 27 urban populations of Brazil from 2006 to 2016: a population-based study. *PLoS One* 2019; 14(3): e0213254.
 39. Robotics e-manual – Dynamixel MX series (MX-64 and MX-106). http://support.robotis.com/en/product/actuator/dynamixel/dxl_mx_main.htm (accessed 19 April 2020).
 40. Woldag H, Stupka K, and Hummelsheim H. Repetitive training of complex hand and arm movements with shaping is beneficial for motor improvement in patients after stroke. *J Rehabil Med* 2010; 42: 582–587.
 41. IEC 80601-2-78:2019, Medical electrical equipment. Geneva, Switzerland: IEC, 2019.
 42. Alves T, Chaves M, and Gonçalves RS. Assist-as-needed control in a cable-actuated robot for human joints rehabilitation. *J Mech Eng Biomech* 2019; 3: 57–62.
 43. Hogan N. Impedance control: an approach to manipulation. In: *American Control Conference*, San Diego, CA, USA, 6–8 June 1984, pp. 304–313. IEEE.
 44. Barbosa H, Castro AV, and Carrapatoso E. Serious games and rehabilitation for elderly adults. *Global Sci J* 2018; 6(1): 275–283.
 45. Fang S. Matlab unity 3D UDP connection, 2016. <https://github.com/aerogelcube/MatlabUnityUDP> (accessed 19 April 2020).
 46. Burke JW, McNeill M, Charles D, et al. Serious games for upper limb rehabilitation following stroke. In: *Conference in games and virtual worlds for serious applications*, Coventry, 23–24 March 2009, pp. 103–110. IEEE.
 47. Pinheiro ML, Brito L, and Gonçalves RS. Development of serious game for a robotic device to assist at wrist rehabilitation. In: *25th international congress of mechanical engineering*, Uberlândia/MG, Brazil, January 2019, pp. 1–7. ABCM.
 48. Center for Self-Determination Theory, Intrinsic Motivation Inventory (IMI). <http://selfdeterminationtheory.org/intrinsic-motivation-inventory> (accessed 28 March 2020).
 49. Ijsselstein WA, de Kort YAW, and Poels K. *The game experience questionnaire*. Eindhoven: Technische Universiteit Eindhoven, 2013.
 50. Al-Achi A. The student's t-test: a brief description. *Res Rev J Hosp Clin Pharm* 2019; 5(1): 1–3.

51. Reissner L, Fischer G, List R, et al. Minimal detectable difference of the finger and wrist range of motion: comparison of goniometry and 3D motion analysis. *J Orthop Surg Res* 2019; 14: 173.
52. Keogh JW, Cox A, Anderson S, et al., Reliability and validity of clinically accessible smartphone applications to measure joint range of motion: a systematic review. *PLoS One* 2019; 14(5): e0215806.
53. Chumney D, Nollinger K, Shesk Skop K, et al. Ability of functional independence measure to accurately predict functional outcome of stroke-specific population: systematic review. *J Rehabil Res Develop* 2010; 47: 17–30.