

Apolipoprotein C-II deficiency: detection of immunoreactive apolipoprotein C-II in the intestinal mucosa of two patients

A. Capurso,* A. M. Mogavero,* F. Resta,* M. Di Tommaso,* P. Taverniti,* F. Turturro,* M. La Rosa,† S. Marcovina,** and A. L. Catapano^{1,††}

Istituto di Clinica Medica II, Università di Bari;* Istituto di Clinica Pediatrica, Università di Catania;† Ospedale S. Raffaele, Milano;** and Institute of Pharmacological Sciences, School of Pharmacy, University of Milano,†† Italy

Abstract Recent data suggest that mutant immunoreactive forms of apolipoprotein C-II (apoC-II) can be detected in the plasma of patients with the apoC-II deficiency syndrome. We studied the possible presence of apoC-II mutants in the plasma of two patients with apoC-II deficiency by immunological means. The patients were hypertriglyceridemic, and apoC-II was undetectable in plasma as determined by radial immunodiffusion, electroimmunoassay, and immunonephelometry. Furthermore, apoC-II was undetectable either by electrophoresis or by immunoblotting in the plasma of the probands, while apoC-II was present in the plasma of their parents, although at less than half-normal concentration. Immunochemical localization of apoC-II, however, showed that the apoprotein could be detected within the enterocytes obtained from the intestinal mucosa of the patients. From these data we conclude that the patients synthesize apoC-II, at least in the intestine. — Capurso, A., A. M. Mogavero, F. Resta, M. Di Tommaso, P. Taverniti, F. Turturro, M. La Rosa, S. Marcovina, and A. L. Catapano. Apolipoprotein C-II deficiency: detection of immunoreactive apolipoprotein C-II in the intestinal mucosa of two patients. *J. Lipid Res.* 1988. 29: 703–711.

Supplementary key words enterocytes • lipoproteins • apolipoproteins

Apolipoprotein C-II (apoC-II), a protein component of chylomicrons, very low density lipoproteins (VLDL), and high density lipoproteins (HDL), is the physiological activator of lipoprotein lipase (LPL), the enzyme that hydrolyzes the triglycerides of chylomicrons and VLDL at the surface of the capillary endothelium (1–3).

Several patients with apoC-II deficiency have been described since 1978 (4–10). These patients, in spite of the presence of functional lipoprotein lipase, have severe hypertriglyceridemia and impaired plasma clearance of chylomicrons and VLDL which can be corrected, in part, by plasma infusion (4, 6, 7).

Recently, nonfunctional mutant forms of apoC-II have been detected in the plasma of apoC-II-deficient patients

(11). These forms of apoC-II have a molecular weight similar to that of functional apoC-II, but do not activate lipoprotein lipase, cannot form insoluble antigen–antibody complexes with polyclonal antibodies to apoC-II, and focus at an apparent isoelectric point of 5.54 and 5.15, respectively, in polyacrylamide gel isoelectric focusing (11).

In the present report we describe studies aimed at identifying the presence of apoC-II mutant forms in the plasma of two patients with apoC-II deficiency, and the presence of immunoreactive apoC-II in the intestinal mucosa of these patients. One of the patients was described previously (7, 12).

CASE REPORT

The patients, two siblings, were a 12-year-old girl (B) and an 8-year-old boy (A). The parents were distant relatives (Fig. 1). The girl was admitted to the hospital at the age of 6 because of diarrhea, and a milky serum was discovered. Her plasma triglyceride and cholesterol levels were 2,750 mg/dl and 110 mg/dl, respectively. Her brother, although apparently healthy, had a plasma triglyceride level of 9,450 mg/dl and a cholesterol concentration of 305 mg/dl. Since that time the children have been in good health and asymptomatic. A mild hepatosplenomegaly was observed; xanthomas were absent; and tonsils were normal. Fasting blood glucose was in the normal range, and normal insulin and glucose responses were found

Abbreviations: apoC-II, apolipoprotein C-II; apoC-III, apolipoprotein C-III; LPL, lipoprotein lipase; VLDL, very low density lipoproteins; HDL, high density lipoproteins.

¹To whom correspondence should be addressed at: Institute of Pharmacological Sciences, Via A. Del Sarto 21, Milano, Italy.

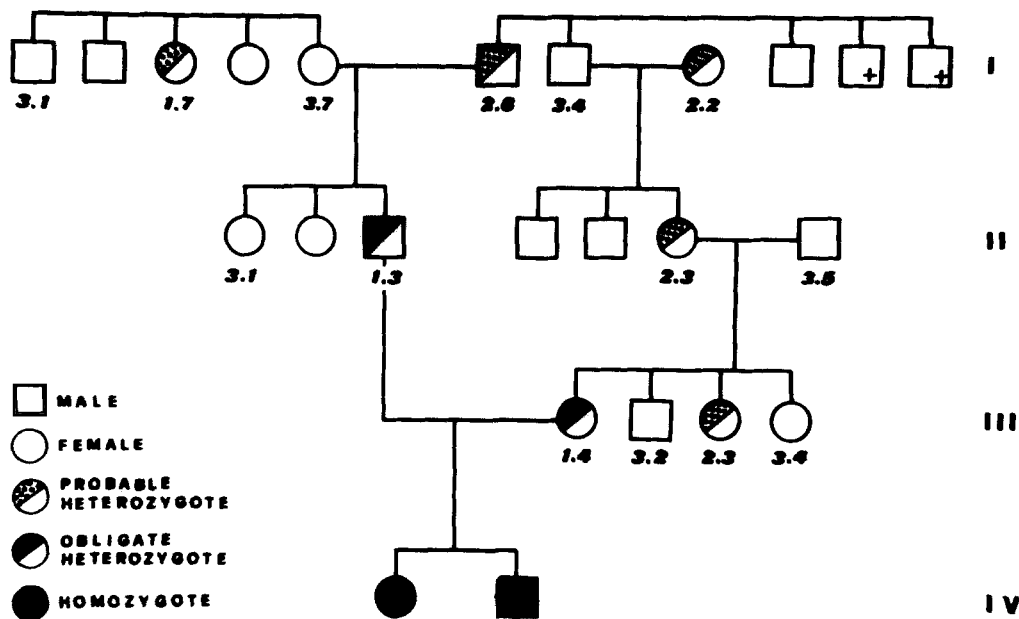

Fig. 1. Family tree (four generations) of the apoC-II-deficient probands. Numbers under symbols are the apolipoprotein C-II plasma values (mg/dl).

after an oral glucose tolerance test. There was no sign of thyroid dysfunction. All other routine serum analytes were within the normal range. At present, the children have triglyceride levels of 604 and 806 mg/dl, respectively. They consume a fat-restricted diet, which apparently allows good control of the plasma lipid levels.

Family screening was carried out for all the extended family. Plasma lipid and apolipoprotein levels of the members of this family are listed in **Table 1**.

MATERIALS AND METHODS

Blood samples were obtained by venipuncture following a 14-hr fast. The blood was collected in EDTA-containing tubes (1 mg/ml of blood) and was centrifuged at 1500 *g* for 10 min at 4°C to obtain plasma. Lipoproteins were isolated by sequential ultracentrifugation according to Havel, Eder, and Bragdon (13) in a Beckman L2-65 ultracentrifuge. Aliquots of isolated lipoproteins were dialyzed against distilled water containing 0.1 g/l Na₂ EDTA adjusted to pH 8.2. The protein content of the lipoprotein fractions was determined by the method of Lowry et al. (14) in presence of 0.1% SDS to avoid turbidity due to lipids. After dialysis, the lipoproteins were delipidated with ethanol-ether 3:1 (v/v) (15). The resulting apoproteins were dried under a stream of nitrogen and stored at -20°C for further analysis.

Plasma cholesterol, triglycerides, and lipoprotein lipids were determined by enzymatic colorimetric methods (Wako Chemicals GmBA, Neuss, F.R.G.).

Postheparin lipase activities

Postheparin lipase lipolytic activity was determined in plasma obtained 10 min after an intravenous injection of 80 I.U./kg body weight of heparin. The lipolytic activity was determined as described by Krauss, Levy, and Fredrickson (16) using [³H]triolein (Amersham, U.K.) as substrate. The hepatic lipase activity was determined by inhibition of the lipoprotein lipase activity with protamine sulfate (16).

The ability of the VLDL of the probands to act as substrate for lipoprotein lipase purified from bovine milk (kindly supplied by Dr. P. K. J. Kinnunen, Helsinki, Finland) was determined using control VLDL and the proband VLDL as previously described (8, 17, 18).

Immunonephelometric assay procedure

The measurements were carried out on a Behring Laser Nephelometer (Behring Institut, Marburg, F.R.G.). Plasma samples were diluted 10-fold with 0.15 M NaCl, containing the nonionic detergent Thesit (Behring Institut) at a concentration of 0.5% w/v. The plasma from the apoC-II-deficient subjects was used undiluted. The antisera to apoC-II were diluted 5-fold with 10 mM Naphosphate buffer, pH 7.4, containing 0.15 M NaCl and 40 g/l of polyethyleneglycol (mol wt, 4000, Merck Darmstadt, F.R.G.), and then filtered through a 0.45- μ m pore size filter (Millipore Corp., Bedford, MA). The reaction mixture, containing 200 μ l of diluted antiserum and 100 μ l of the standard or test sample, was incubated at room tem-

TABLE 1. Plasma lipid and apolipoprotein levels in the family of the apoC-II-deficient subjects

	CH	TG	A-I	A-II	B	C-II	C-III	E
	<i>mg/dl</i>							
<u>A</u>	140	604	92	22	67	ND*	12.0	7.5
<u>B</u>	137	806	95	26	69	ND	12.3	6.2
C*	207	224	125	33	86	1.3	12.7	5.8
D*	192	124	130	36	64	1.4	10.9	5.5
E	240	196	117	39	92	1.7	14.3	3.0
F	155	78	132	37	75	2.3	7.6	4.4
G	225	396	135	45	109	2.2	19.1	3.5
H	204	177	132	41	89	2.3	15.9	3.1
I	143	148	106	33	76	2.6	11.3	4.0
Mean ± SEM	195 ± 13	191 ± 39	125 ± 4	38 ± 2	84 ± 5	1.9 ± 0.2	13.1 ± 1.4	4.2 ± 0.4
J	150	99	111	31	80	3.1	9.1	3.5
K	253	190	135	45	93	3.7	16.7	5.5
L	177	104	127	39	84	3.5	8.9	4.8
M	168	75	114	27	78	3.2	9.1	3.3
N	199	85	119	37	81	3.4	11.9	4.6
O	198	80	122	43	84	3.1	10.8	4.6
P	189	99	130	33	91	3.4	6.4	4.0
Mean ± SEM	191 ± 12	104 ± 15	123 ± 3	36 ± 2	84 ± 2	3.3 ± 0.1	10.4 ± 1.2	4.3 ± 0.3

The propositi are underlined; their parents are marked with an asterisk. Mean values ± SEM are presented for the obligate + probable heterozygotes (top, C-I) and normal subjects (bottom, J-P).

*ND, not detectable.

perature for 2 hr. The reagent blank consisted of 100 μ l of diluted plasma (or undiluted patients' plasma) and 200 μ l of the phosphate buffer containing Thesit. Calibration curves were obtained from the appropriate dilutions of a secondary standard formed by pooled sera of normolipemic donors calibrated with purified apoC-II, whose concentration was assayed by rocket immunoelectrophoresis. The assay is sensitive down to 40 ng of apoC-II, with a working range of 78 to 312 ng of apoC-II.

Analytical isoelectric focusing of apoproteins

Analytical isoelectric focusing was performed on 7.5% polyacrylamide gel according to Catapano et al. (19) with 2% ampholines, pH 4-6, (LKB, Bromma, Sweden) in an LKB vertical electrophoresis unit (model 2001). The delipidated lipoproteins were dissolved in 1% decylsulfate (Eastman Kodak), 2% ampholines, pH 4-6, and 0.01 M Tris-HCl, pH 8.2. When reduction of sulfide bonds was required, β -mercaptoethanol (Serva, Heidelberg, F.R.G.) was added to the sample buffer at a final concentration of 1% (v/v). The samples were incubated for 1 hr at room temperature. The focusing was carried out overnight at 140 V and power was limited to 2.5 W per plate on 1.5-mm-thick slab gels. Apoproteins were stained with Coomassie Brilliant Blue G-250 (15). Alternatively, the focusing was performed in gel tubes 5 × 125 mm, in a Bio-Rad Model 155 electrophoresis cell (Bio-Rad, Richmond, CA). Both slab and disc gels were prefocused for 1 hr at 100 V. The anode solution was 0.01 N phosphoric acid; the cathode solution was 0.02 M NaOH.

Polyacrylamide gel blotting

Electrophoretic transfer of apoproteins from isoelectric focusing polyacrylamide gels to unmodified nitrocellulose and subsequent reaction with a monospecific antibody for apoprotein C-II was performed according to Burnette (20). The blotting was run overnight at 60 V, 100 mA at 10°C in a Bio-Rad Trans-Blot cell. The electrophoresis buffer was 0.025 M Tris-0.2 M glycine, 20% methanol, pH 8.3. Following the electrophoretic transfer of proteins, the nitrocellulose membrane was washed for 15 min in phosphate-buffered saline (PBS), pH 7.5, and then incubated in 3% (w/v) bovine albumin-PBS for 1-2 hr in order to block the unbound sites on the membrane. The membrane was then washed in PBS and incubated with a rabbit or goat antiserum to apoC-II, diluted in 3% bovine albumin-PBS solution, for 2-12 hr. After incubation, the membrane was washed in bovine albumin-PBS solution and incubated with the second antibody, fluorescein-labeled or peroxidase-conjugated anti-rabbit or anti-goat IgG (Behring, Marburg, F.R.G.), for 1-6 hr, then washed extensively in PBS, and viewed under ultraviolet light when treated with fluorescein-labeled antibody, or processed with developing solution for peroxidase (30 mg of 3,3-diaminobenzidine-4-HCl dissolved in 100 ml of PBS, containing 0.1 ml of 1% H₂O₂). The reaction was stopped by rinsing with tap water.

Two-dimensional polyacrylamide SDS gel electrophoresis

The two-dimensional electrophoresis was performed in a discontinuous SDS system according to Neville (21). After

isoelectric focusing, strips of polyacrylamide gel corresponding to one lane containing apoVLDL were cut and equilibrated for 15 min in 0.002 M methylmorpholine-HCl solution, pH 8.5, 0.2% SDS, 1.1% β -mercaptoethanol, 0.001% bromophenol blue, and 4% sucrose. After incubation, the strips were placed on the stacking gel of the SDS system for running in the second dimension. The electrophoresis was carried out initially in 15 mA per plate, 200 V, then at 20 mA per plate after the front marker had reached the separating gel. As molecular weight markers, the electrophoresis calibration kit-low molecular weight (Pharmacia, Uppsala, Sweden) was used.

The gel was stained with 2% Coomassie Blue G-250 in 50% methanol and 12% acetic acid for 1 hr at room temperature, and then destained in 20% methanol until a satisfactory background was obtained. To increase the sensitivity, the gels were restained with the silver stain technique according to Merrill et al. (22).

Other immunological methods

The immunological investigations on apoC-II were performed with two different antisera: 1) a rabbit anti-human apoC-II serum, prepared in our laboratories as described elsewhere (23); and 2) a goat anti-human apoC-II serum purchased from Daiichi (Tokyo, Japan). To raise antibodies, purified apoC-II emulsified with complete Freund adjuvant was injected in the back of a rabbit every 3 weeks (usually three times). The specificity of the antiserum was determined by double immunodiffusion using purified lipoproteins and apoproteins, and by immunoblotting. The antiserum reacted only with VLDL, HDL, and apoC-II; it did not react with LDL, apoA-I, A-II, C-III, and E. Monospecificity was also evaluated by immunoblotting on the $d < 1.21$ g/ml fraction from normal plasma. Only one band corresponding to apoC-II was detected.

Monospecific antibodies for apoA-I, A-II, and C-III, all raised in rabbits, were prepared in our laboratories as previously described (23). Anti-apoB was purchased from Behring (Behring Institut, Marburg, F.R.G.). Antibody to apoE was a gift from Dr. Petar Alaupovic (Oklahoma Medical Research Foundation, Oklahoma City, OK). Evaluation of serum apoproteins was performed by radial immunodiffusion and by electroimmunoassay (rockets) (24).

Immunological detection of apoC-II in the intestinal mucosa

Samples of duodenal and jejunal mucosa were obtained by peroral biopsy, performed during a gastroduodenal endoscopic examination. ApoC-II in the biopsy specimens was detected by immunofluorescence and immunoperoxidase methods on fresh-frozen, unfixed sections, 4 μ m thick.

The immunofluorescence was performed by both a direct and an indirect method.

Direct method. The cryostat sections were incubated with fluorescein-labeled rabbit anti-human apoC-II serum in a moist chamber for 30 min at room temperature, then washed three times with PBS.

Indirect method (double antibody method). The cryostat sections were first incubated with unconjugated rabbit or goat anti-human apoC-II, then washed repeatedly in PBS and incubated with the fluorescein-labeled second antibody (anti-rabbit or anti-goat IgG). As control, adjacent sections were incubated with: 1) fluorescein-labeled normal (nonimmune) rabbit or goat IgG; 2) unconjugated monospecific anti-apoC-II serum, then with the same fluorescein-labeled specific antibody (extinction test); 3) normal rabbit or goat serum, then with fluorescein-labeled second antibody. The labeling of anti-apoC-II IgG with fluorescein was performed according to the method of Cherry, Goldman, and Carski (25). After coupling, the unreacted dye was removed from fluorescein-conjugated IgG by gel filtration on a Sephadex G-25 column.

The immunoperoxidase reaction was performed with the double antibody method (indirect method) and with the triple-bridge + PAP method, according to Sternberger et al. (26). The PAP complex was purchased from Sigma (St. Louis, MO). The intestinal endogenous peroxidase was inhibited with methanol-H₂O₂ prior to the start of the immunological reaction.

RESULTS

Plasma cholesterol and triglyceride concentrations in the probands and their parents are reported in Table 1. Plasma triglycerides in the apoC-II-deficient patients are high, while concentrations in the parents were within the normal range or slightly increased. The relatively low value of plasma TG in the probands is due to treatment with a fat-restricted diet (2, 7).

The serum lipid and apoprotein levels of the probands, their parents, and relatives are also shown in Table 1. The apoA-I and A-II values of probands B and A are slightly lower and apoE higher than controls (matched by age and sex; not shown) while apoC-II was not detectable. Plasma levels of apolipoprotein A-I, A-II, B, and E of the parents were within the normal range. ApoC-II was roughly half normal, suggesting a condition of heterozygosity for the disease. Serum cholesterol, triglyceride, and apoprotein data of the kindred (four generations) are also summarized in Table 1. The family tree is shown in Fig. 1. The heterozygotes are tentatively identified by the values of serum apoC-II, as suggested by Cox, Breckenridge, and Little (27).

To further stress the concept that the hypertriglyceridemia detected in our patients was due to the apolipoprotein C-II deficiency, we determined hepatic and lipoprotein lipase in postheparin plasma. The postheparin lipolytic activity in the plasma of our probands was within the normal range (26.7 and 29.2 μmol of free fatty acid/ml \cdot hr⁻¹). Lipoprotein lipase and hepatic lipase were also normal (LPL, 6.9 and 7.9; hepatic lipase, 19.8 and 21.3) although the hepatic lipase was borderline (normal range for LPL, 6-12; for HL, 20-30 μmol of free fatty acid/ml \cdot hr⁻¹, n = 8). We have previously reported that VLDL from the probands were a poor substrate for LPL as compared to control VLDL; addition of purified apoC-II almost completely restored the hydrolysis of VLDL triglycerides, thus showing a lack of functional apoC-II in the plasma of the patients (8). Similar data were obtained with the VLDL of the second patient (data not shown).

The polyacrylamide gel isoelectric focusing profile of apoVLDL is shown in Fig. 2. Compared to normal VLDL, the proband's VLDL did not show any apoC-II₁ or apoC-II₂ band while other apoproteins were present. Furthermore, no apoC-II could be detected by immunoblotting and no apoproteins corresponding to any known isoform of apoC-II were observed in two-dimensional gel electrophoresis (Fig. 3). A faint band running close to the position of apoC-II was detectable but did not immuno-

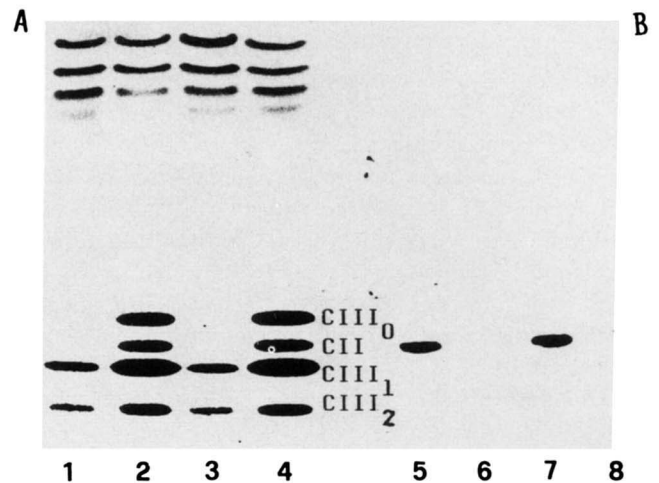

Fig. 2. Isoelectric focusing (panel A), and immunological detection of apoC-II after Western blotting (panel B) in VLDL from controls (lanes 2, 4, 5, and 7) and from the patients (lanes 1, 3, 6, and 8). Isoelectric focusing and electrophoretic transfer were performed as described in Methods. After a first incubation with a rabbit polyclonal antibody to apoC-II, a second antibody (anti-rabbit IgG) conjugated to peroxidase was used for detection of the C-II-antibody complex. ApoC-II and apoC-III₀, apoC-III₁, and apoC-III₂ are indicated.

react with antibodies to apoC-II and appeared only in samples aged 1 week or more (see below).

To rule out the possibility that mutant forms of apoC-II were present in the plasma of our probands, the apo-

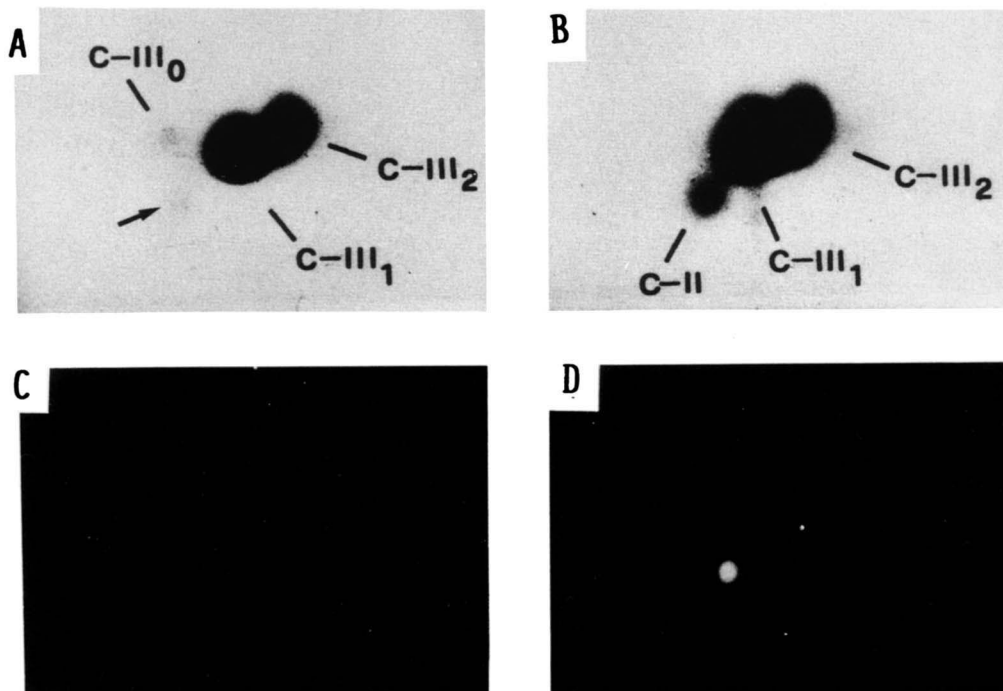

Fig. 3. Two-dimensional gel electrophoresis of apoVLDL from a proband (B). No apoC-II was detectable in the area where the apoprotein is found, either with Coomassie blue staining (panel A, proband; panel B, control) or by immunological reaction after Western blotting, using a rabbit polyclonal antibody, which was detected with a fluorescein-conjugated anti-IgG, (proband, panel C; control, panel D). ApoC-III₀, C-III₁, C-III₂, and C-II are indicated for comparison purposes. The arrow (panel A) indicates the spot that has a mobility similar to that of apoC-II but is not immunodetectable after Western blotting (panel C) (see text for further details).

proteins of VLDL or of the $d < 1.006$ g/ml fraction were first transferred by blotting onto a nitrocellulose membrane and then allowed to react with a monospecific polyclonal antibody for apoC-II. We failed to demonstrate any reactivity in the proband samples, while apoC-II of normal VLDL was easily detectable (Fig. 2). Also, the LDL, HDL, and total plasma of the probands did not show any immunological reaction for apoC-II (data not shown). Very similar results were obtained with two-dimensional gel electrophoresis (Fig. 3). ApoC-II was also not detectable in the plasma of our patients by immunonephelometry (0.04 mg/dl was detectable by this method), thus showing that very little, if any, apoC-II was present in the plasma of the patients.

To address the question of whether apoC-II is synthesized at all in our patients, we performed immunolocalization of apolipoprotein C-II in an intestinal mucosa sample. The immunological reaction with fluorescein-labeled anti-apoC-II serum showed, in both the normal

and proband intestinal samples, a specific immunofluorescence reaction localized in the supranuclear region of the jejunal enterocytes, throughout the length of the villus (Fig. 4, panels A and B). The intensity of the reaction was even stronger in the proband specimen. The immunoperoxidase reaction gave essentially the same results as the immunofluorescence study (data not shown).

DISCUSSION

In this paper we report studies on the immunological properties and cellular localization of apoC-II in two siblings with apoC-II deficiency. One of the patients (B) was previously described in detail (7, 12), while her brother is described for the first time. Both have severe hypertriglyceridemia which is well controlled by a fat-restricted diet.

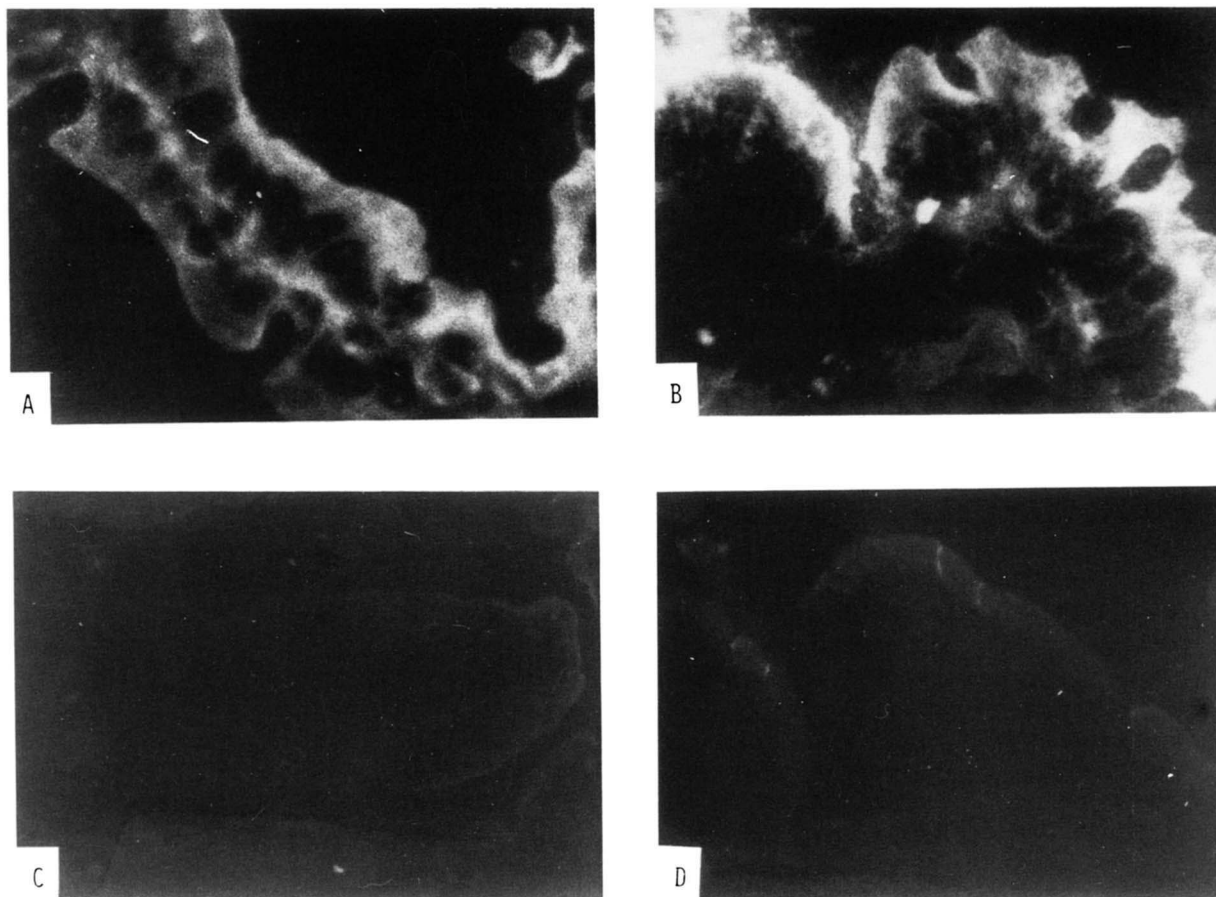

Fig. 4. Panel A: immunodetection of apoC-II in an intestinal biopsy from a control subject. A specific immunofluorescent reaction was detected in the cytoplasm of intestinal mucosal cells with the most intensive staining at the site of the lumen ($\times 250$). Antibodies to apoC-II (goat) were detected by using a fluorescein-conjugated second (anti-IgG) antibody. See text for details. Panel B: immunodetection of apoC-II in an intestinal biopsy of patient B. The specific immunofluorescent reaction was detected in the cytoplasm of intestinal mucosal cells with the most intensive staining at the luminal site ($\times 250$). Panels C and D: control experiments for the reaction shown in panels A and B. The samples were treated exactly as the others with the exception that anti-apoC-II was not added ($\times 250$).

The patients have the hallmarks of the apoC-II deficiency (see case report). Furthermore, plasma infusion dramatically reduced plasma triglyceride levels in patient B (7). We have not performed this experiment in patient A.

The plasma levels of immunodetectable apoC-II were low (about 50% of normal) in both parents of the probands, suggesting heterozygosity for apoC-II deficiency, as demonstrated by Cox et al. (27). Consanguineous mating has been described in several members of this family as well as in other kindreds of apoC-II deficiency (4, 6, 27).

The clinical data show that the diagnosis of apoC-II deficiency in both probands is correct and this is further stressed by the lack of detectable apoC-II in the probands' plasma as determined by isoelectric focusing, two-dimensional electrophoresis, immunonephelometry, and immunoblot analysis (Figs. 2, 3). This is at variance with other data (11). These authors (11) demonstrated the presence of at least two immunoreactive forms of apoC-II in the VLDL of apoC-II-deficient patients; one form was five amino acids short at the COOH terminus (28). A second mutant form has also been detected in an Italian kindred (29) that clearly differs from the aforementioned mutation.

The sensitivity of the immunonephelometric method we used is down to 40 $\mu\text{g}/\text{dl}$ of apoC-II. Concentrations lower than that cannot be reliably detected. Thus, we can only identify our patients as C-II-deficient. Furthermore, the possibility that mutant forms of apoC-II are being synthesized in our patients cannot be excluded a priori. Proteins of very low molecular weight would diffuse out of the gel during washing and staining, and therefore they would not be detectable by our methods; alternatively, such a mutant protein may lose its immunoreactivity after blotting. This second possibility, however, is unlikely since it would imply that several epitopes on a mutant form have to be destroyed during blotting while apoC-II maintains its immunoreactivity. Furthermore, if apoC-II mutant forms that do not immunoprecipitate were to be present in the plasma of the patients, they should be detectable by immunonephelometry. We failed to demonstrate any apoC-II using this technique. A further possibility is that apoC-II mutant forms are produced by our probands that are not recognized by the antibodies we used. The epitopes recognized by polyclonal antibodies to apoC-II are unknown; however, it appears unlikely that all are lost in a mutant form and this is further stressed by the fact that immunoreactive apoC-II was detectable in the intestinal mucosa of the patients.

In two-dimensional gel electrophoresis patterns a small spot in the apoC-II area was detectable. The band appeared only upon aging of the sample (VLDL older than 7 days) and was not detectable on fresh samples. This band is not apoC-II since comparable amounts of authen-

tic apoC-II, as judged by the Coomassie blue staining intensity, are easily detectable with our antibodies.

To address more directly the question of whether apoC-II is synthesized at all in our patients, we performed immunolocalization of apoC-II in intestinal biopsies obtained from the probands and from normolipidemic controls. ApoC-II is believed to be synthesized largely by the liver in rat and in man (30, 31). ApoC-II, however, is immunodetectable in human and rat intestinal mucosa as well (32) and apoC-II mRNA is found in fetal human intestine and liver (33). In our patients apoC-II was detectable after a 12- to 14-hr fast and was present in the supranuclear area of the enterocyte, in agreement with data reported by Schonfeld, Grimme, and Alpers (32). This suggests the presence of apoC-II in the Golgi apparatus, a cellular localization that argues against a contamination with blood-derived apoC-II, which, moreover, was not detectable in the plasma.

The question then arises: why could we not detect apoC-II in the plasma of the patients by immunochemical means if apoC-II can be detected in intestinal cells? This is reminiscent of Tangier patients whose plasma apoA-I levels are very low (1-2% of controls) while intestinal cells contain a high amount of the apoprotein (34). Recently Dullaart et al. (35) reported the presence of immunochemically detectable apoB in the enterocytes of patients with abetalipoproteinemia. It is possible to speculate that a mutant form of apoC-II is produced that is removed very rapidly from circulation, or it may lack some signals to be correctly processed within the cell and therefore cannot be associated to nascent lipoproteins. The plasma levels of such a mutant apoprotein would then be too low to be detected by our methods (less than 1% of "normal" values). A third explanation relates to the observation that apoC-II, at least in rats, is synthesized mainly by the liver (30), and mRNA for apoC-II is most abundant in human liver (33). Since we have not studied the presence of apoC-II in the hepatocyte, we may speculate that the liver might not be able to produce apoC-II in our apoC-II-deficient patients. This possibility, although likely, still remains to be tested since at least two forms of apoC-II have been detected in human plasma (36). Evidence for a separate genetic control of two apoB forms (apoB-100 and B-48) has been reported (37); this could also apply to apoC-II (38). ■

The authors wish to thank Dr. P. Alaupovic for the generous gift of antibodies to apoE, and Mrs. Silvana Magnani for typing the manuscript. Supported in part by grants from the Consiglio Nazionale delle Ricerche, Italy, P.F. Ingegneria Genetica e Basi Molecolari delle Malattie Ereditarie ob. 13, and of P.F. Malattie Degenerative Aterosclerosi ob. 43, to A. C. and to A. L. C.

Manuscript received 26 March 1987, in revised form 28 September 1987, and in re-revised form 23 November 1987.

REFERENCES

- Zannis, V. I., and J. L. Breslow. 1985. Genetic mutation affecting human lipoprotein metabolism. In *Advances in Human Genetics*. M. Harris and K. Hirschhorn, editors. Plenum Publishing Co., New York. 125-215.
- Gotto, A. M. 1984. Apolipoprotein C-II deficiency revisited. *N. Engl. J. Med.* **310**: 1664-1665.
- La Rosa, J. C., I. Levy, P. Herbert, S. E. Lux, and D. S. Fredrickson. 1970. A specific apoprotein activator for lipoprotein lipase. *Biochem. Biophys. Res. Commun.* **41**: 45-62.
- Breckenridge, W. C., J. A. Little, G. Steiner, A. Chow, and M. Poapst. 1978. Hypertriglyceridemia associated with deficiency of apolipoprotein C-II. *N. Engl. J. Med.* **298**: 1265-1273.
- Yamamura, T., H. Sudo, K. Ishikawa, and A. Yamamoto. 1979. Familial type I hyperlipoproteinemia caused by apolipoprotein C-II deficiency. *Atherosclerosis*. **34**: 53-65.
- Miller, N. E., S. N. Rao, P. Alaupovic, N. Noble, J. Slack, J. D. Brunzell, and B. Lewis. 1981. Familial apolipoprotein C-II deficiency: plasma lipoproteins and apolipoproteins in heterozygous and homozygous subjects and the effects of plasma infusion. *Eur. J. Clin. Invest.* **11**: 69-76.
- Stalenhoef, A. F. H., A. F. Caspaire, P. N. M. Demaker, J. T. J. Stouten, J. A. Luttermann, and A. Van't Laar. 1981. Combined deficiency of apolipoprotein C-II and lipoprotein lipase in familial hyperchylomicronemia. *Metabolism*. **30**: 919-926.
- Catapano, A. L., G. L. Mills, P. Roma, M. La Rosa, and A. Capurso. 1983. Plasma lipids, lipoproteins and apolipoproteins in a case of apoC-II deficiency. *Clin. Chim. Acta.* **130**: 317-327.
- Fellin, R., G. Baggio, A. Poli, J. Augustin, M. R. Baiocchi, G. Baldo, M. Senigalia, H. Greten, and G. Crepaldi. 1983. Familial lipoprotein lipase and apolipoprotein C-II deficiency. *Atherosclerosis*. **49**: 55-68.
- Saku, K., C. Cedres, B. McDonald, B. Hynd, B. W. Liu, L. S. Srivastava, and M. L. Kashyap. 1984. C-II anapolipoproteinemia and severe hypertriglyceridemia. *Am. J. Med.* **77**: 457-462.
- Maguire, G. F., J. A. Little, G. Kakis, and W. C. Breckenridge. 1984. Apolipoprotein C-II deficiency associated with nonfunctional mutant forms of apolipoprotein C-II. *Can. J. Biol.* **62**: 847-852.
- Capurso, A., L. Pace, L. Bonomo, A. L. Catapano, G. Schilirò, M. La Rosa, and G. Assmann. 1980. New case of apoprotein C-II deficiency. *Lancet*. **I**: 268.
- Havel, R. J., H. A. Eder, and J. H. Bragdon. 1955. The distribution and chemical composition of ultracentrifugally separated lipoproteins in human serum. *J. Clin. Invest.* **34**: 1345-1354.
- Lowry, O. H., N. J. Rosebrough, A. L. Farr, and R. J. Randall. 1951. Protein measurement with the Folin phenol reagent. *J. Biol. Chem.* **193**: 265-275.
- Scanu, A. M., and C. E. Edelstein. 1971. Solubility in aqueous solution of ethanol of the small molecular weight peptides of the very low density and high density lipoproteins. *Anal. Biochem.* **44**: 576-588.
- Krauss, R. M., R. I. Levy, and D. S. Fredrickson. 1979. Selective measurement of two lipase activities in post-heparin plasma from normal subjects and patients with hyperlipoproteinemia. *J. Clin. Invest.* **63**: 1107-1124.
- Catapano, A. L., P. K. J. Kinnunen, W. K. Breckenridge, A. M. Gotto, Jr., R. L. Jackson, J. A. Little, L. C. Smith, and J. T. Sparrow. 1979. Lipolysis of apoC-II-deficient very low density lipoproteins: enhancement of lipoprotein lipase action by synthetic fragments of apoC-II. *Biochem. Biophys. Res. Commun.* **89**: 951-957.
- Belfrage, P., and M. Vaughan. 1969. Simple liquid-liquid partition system for isolation of labeled oleic acid from mixtures with glycerides. *J. Lipid Res.* **10**: 341-344.
- Catapano, A. L., R. L. Jackson, E. B. Gilliam, A. M. Gotto, Jr., and L. C. Smith. 1978. Quantification of apoC-II and apoC-III of human very low density lipoproteins by analytical isoelectric focusing. *J. Lipid Res.* **19**: 1047-1052.
- Burnette, W. N. 1981. "Western blotting": electrophoretic transfer of proteins from sodium dodecyl sulfate polyacrylamide gels to unmodified nitrocellulose and radiographic detection with antibody and radioiodinated protein A. *Biochemistry*. **112**: 195-203.
- Neville, D. M. 1971. Molecular weight determination of protein-dodecyl sulfate complexes by gel electrophoresis in a discontinuous buffer system. *J. Biol. Chem.* **246**: 6328-6334.
- Merril, C. E., D. Goldman, S. A. Sedman, and M. H. Ebert. 1981. Ultrasensitive stain for proteins in polyacrylamide gels shows regional variation in cerebrospinal fluid proteins. *Science*. **211**: 1437-1438.
- Capurso, A., L. Pace, M. Martorano, G. La Rosa, G. Theodossiu, and L. Bonomo. 1980. Immunological profiles of serum lipoproteins. In *Immunity and Atherosclerosis*. P. Constantinides, F. Pratesi, C. Cavallaro, and T. Di Perri, editors. Academic Press, New York. 133-149.
- Curry, M. D., A. Gustafson, P. Alaupovic, and W. J. McConathy. 1978. Electroimmunoassay, radioimmunoassay and radial immunodiffusion assay evaluated for quantitation of human apolipoprotein B. *Clin. Chem.* **24**: 280-286.
- Cherry, W. B., M. Goldman, and T. R. Carski. 1960. Fluorescent antibody techniques in the diagnosis of communicable diseases. U. S. Public Health Service Publ. 729.
- Sternberger, L. A., P. H. Hardy, J. J. Cuculius, and H. G. Meyer. 1970. The unlabelled antibody enzyme method of immunochemistry. Preparation and properties of soluble antigen-antibody complex (horseradish peroxidase-anti-horseradish peroxidase) and its use in identification of spirochaetes. *J. Histochem. Cytochem.* **18**: 315-333.
- Cox, D. W., W. C. Breckenridge, and J. A. Little. 1978. Inheritance of apolipoprotein C-II deficiency with hypertriglyceridemia and pancreatitis. *N. Engl. J. Med.* **299**: 1421-1424.
- Connelly, P. W., G. F. Maguire, T. Hofman, and J. A. Little. 1987. Structure of apolipoprotein C-II Toronto, a nonfunctional human apolipoprotein. *Proc. Natl. Acad. Sci. USA.* **84**: 270-273.
- Baggio, G., E. Manzato, C. Gabelli, R. Fellin, S. Martini, G. B. Enzi, F. Verlato, M. R. Baiocchi, D. L. Sprecher, M. L. Kashyap, H. B. Brewer, and G. Crepaldi. 1986. Apolipoprotein C-II deficiency syndrome. Clinical features, lipoprotein characterization, lipase activity, and correction of hypertriglyceridemia after apolipoprotein C-II administration of two affected patients. *J. Clin. Invest.* **77**: 520-527.
- Wu, A. L., and H. G. Windmueller. 1979. Relative contributions by liver and intestine to individual plasma apolipoproteins in the rat. *J. Biol. Chem.* **254**: 7316-7322.
- Zannis, V. I., J. L. Breslow, T. R. SanGiacomo, D. P. Aden, and B. B. Knowles. 1981. Characterization of the major apolipoproteins secreted by two human hepatoma cell lines. *Biochemistry*. **20**: 7089-7096.
- Schonfeld, G., N. Grimme, and D. Alpers. 1980. Detection of apolipoprotein C in human and rat enterocytes. *J. Cell Biol.* **86**: 562-567.

33. Zannis, V. I., F. S. Cole, C. L. Jackson, D. M. Kurnit, and S. K. Karathanasis. 1985. Distribution of apolipoprotein A-I, C-II, C-III and E mRNA in fetal human tissues. Time-dependent induction of apoE mRNA by cultures of human monocyte-macrophages. *Biochemistry*. **24**: 4450-4455.
34. Glickman, R. M., P. H. R. Green, R. S. Lees, and A. Tall. 1978. Apoprotein A-I synthesis in normal intestinal mucosa and in Tangier disease. *N. Engl. J. Med.* **299**: 1424-1427.
35. Dullaart, R. D. F., B. Speelberg, H. J. Schuurman, R. W. Milne, L. M. Havekes, Y. L. Marcel, H. J. Geuze, M. M. Hulshof, and D. W. Ekkelens. 1986. Epitopes of apolipoprotein B-100 and B-48 in both liver and intestinal expression and evidence for local synthesis in recessive abetalipoproteinemia. *J. Clin. Invest.* **78**: 1397-1404.
36. Havel, R. J., L. Kotite, and J. P. Kane. 1979. Isoelectric heterogeneity of the cofactor protein for lipoprotein lipase in human blood plasma. *Biochem. Med.* **21**: 121-128.
37. Malloy, M. J., J. P. Kane, R. L. Hardman, R. L. Hamilton, and K. B. Dalal. 1981. Normotriglyceridemic abetalipoproteinemia. *J. Clin. Invest.* **67**: 1441-1450.
38. Menzel, H. J., J. P. Kane, M. J. Malloy, and R. J. Havel. 1986. A variant primary structure of apolipoprotein C-II in individuals of African descent. *J. Clin. Invest.* **77**: 595-601.