

Simple detection of a point mutation in LDL receptor gene causing familial hypercholesterolemia in southern Italy by allele-specific polymerase chain reaction

Alfredo Cantafora,^{1,*} Ida Blotta,* Elisabetta Mercuri,* Sebastiano Calandra,[†] and Stefano Bertolini[§]

Laboratorio di Metabolismo e Biochimica Patologica,* Istituto Superiore di Sanità, Roma 00161, Italy; Dipartimento di Patologia Generale,[†] Università di Modena, Modena 41100, Italy; and Dipartimento di Medicina Interna,[§] Servizio di Prevenzione Arteriosclerosi, Università di Genova, Genova 16132, Italy

Abstract Polymerase chain reaction (PCR) amplification of specific alleles allowed the rapid detection of a point mutation (missense Gly⁵²⁸ → Asp) in exon 11 of the low density lipoprotein receptor gene which was otherwise not detectable by exon amplification and enzymatic digestion as it does not modify the normal restriction pattern. The mutant allele, designated as FH-Palermo-1 from the origin of the first carrier family identified, gave a specific PCR product of 109 bp clearly distinct from the product of 168 bp obtained from other alleles with a nonspecific couple of primers. This method allowed us to distinguish one positive sample mixed with up to 11 parts of normal DNA. Furthermore, the specific amplification product was characterized by a Bsm I restriction site not present in nonspecific products.—Cantafora, A., I. Blotta, E. Mercuri, S. Calandra, and S. Bertolini. Simple detection of a point mutation in LDL receptor gene causing familial hypercholesterolemia in southern Italy by allele-specific polymerase chain reaction. *J. Lipid Res.* 1998. 39: 1101–1105.

Supplementary key words allele-specific primers • polymerase chain reaction amplification of specific alleles

There is great interest in the development of simple methods to detect known single-base mutations underlying severe genetic disorders. Amplification by polymerase chain reaction (PCR) of a specific DNA region affected by mutation followed by its digestion with an endonuclease offers a straight solution to this problem when the restriction pattern of this region is affected by the mutation under examination (1). However, the two-step approach has the inconvenience of being labor-intensive and inapplicable to mutations that do not modify the restriction pattern or that affect it with scarcely detectable changes (2).

At end of the 1980s, different authors proposed a much simpler approach to detection of known single-base changes that consists of the PCR amplification of DNA templates

with specially designed primers that preferentially amplify the mutant allele over the wild allele. This strategy was variously defined as PCR amplification of specific allele (PASA) (3), allele-specific amplification (ASA) (4), allele-specific PCR (ASPCR) (5), and amplification-refractory mutation system (ARMS) (6). In general, a perfectly matched primer set amplifies the desired allele while the other allele is poorly or not at all amplified because it mismatches at (or near) the 3' end of the allele-specific primer.

The design of an allele-specific primer may encounter difficulties because only a few mismatches (i.e., A/G, G/A, C/C, and A/A) at the 3' primer extreme reduce the yield of PCR amplification (7). Furthermore, amplification parameters (i.e., annealing temperature, Mg²⁺, dNTP, and primer concentration) and the presence of competitive primers may affect intensity and specificity of amplification (8, 9). However, the approach appeared attractive enough to induce us to develop a simple PASA assay for a single-base mutation in exon 11 of the LDL receptor (LDL-R) gene that is otherwise not detectable by exon amplification and enzymatic digestion as it does not modify the normal restriction pattern. This mutation, which causes a severe form of familial hypercholesterolemia (FH), was detected for the first time by Hobbs et al. (10) as a missense Gly → Asp at codon 528 (i.e., GGT → GAT). The mutant allele was found in an Italian patient with homozygous FH. The patient, who was from Sicily, was referred to Hobbs by the Childrens' Hospital "G. Gaslini" in Genoa, and so the mutation was erroneously designated FH-Genoa. Further investigations carried out in our coun-

Abbreviations: FH, familial hypercholesterolemia; LDL, low density lipoproteins; PCR, polymerase chain reaction; PASA, PCR amplification of specific alleles; dNTP, deoxynucleoside triphosphate; bp, base pair(s).

¹To whom correspondence should be addressed.

try allowed the detection of this mutation in two other unrelated homozygotes and in several other heterozygotes from the southern Italian mainland and from Sicily (S. Bertolini and S. Calandra, unpublished results). The mutation was then renamed FH-Palermo-1.

Here we describe development and utilization of a PASA test that was demonstrated to be adequate to conduct a rapid and reliable screening of allele FH-Palermo-1 in a large number of Italian patients with clinically diagnosed FH.

MATERIALS AND METHODS

Genomic DNA was extracted from peripheral blood leukocytes of patients affected by FH and control donors by a standard procedure (11). There was institutional approval of the study, and informed consent was obtained from the probands and healthy control subjects.

The strategy used for our PASA protocol is illustrated in Fig. 1. Briefly, the mutant allele FH-Palermo-1 has a C/T mismatch at the 3' end of specific (forward) primer. This mismatch does not inhibit the annealing of primer and the forward strand is amplified. The normal allele has a C/C mismatch at the 3' end of specific primer. In this case the mismatch prevents the annealing

and the amplification of the sense strand. The reverse primer is an allele-nonspecific primer used for amplification of exon 11, previously described by Hobbs, Brown, and Goldstein (12). The addition of a further forward primer, allele-nonspecific, such as the forward allele-nonspecific primer described by Hobbs et al. (12), allowed the so-called competitive priming: the mutant allele FH-Palermo-1 gave a specific amplification band of 109 bp, while the wild allele gave a nonspecific amplification band of 168 bp. The specific amplification band of allele FH-Palermo-1 is characterized by the presence of a Bsm I restriction site (GAATGCT[^]G) which is introduced by both primer mismatch and mutation itself. Nonspecific amplification band does not contain any Bsm I restriction site. Thus, the splitting of the 109 bp band into fragments of 83 and 26 bp after a short digestion with Bsm I enzyme allows us to distinguish a genuine specific amplification band of FH-Palermo-1 allele from any possible spurious amplification product.

The PASA test was carried out in a final volume of 50 μ L of reaction mixture containing 0.25 μ g of template DNA, 10 pmol of allele-specific forward primer (5'-AGA TCA AGA AAG GGG GCC TGA ATG C-3'), 10 pmol of reverse nonspecific primer (5'-TGG GAC GGC TGT CCT GCG AAC ATA C-3'), 10 nmol each of dNTPs, 1.0 U of Taq DNA polymerase (Promega Corp., Madison, WI), buffered with 50 mM KCl, 10 mM Tris-HCl, 1.5 mM MgCl₂, 0.1 mg/ml gelatin, at pH 8.3. The PCR was run with an initial denaturation of the DNA template at 94°C for 7 min followed by 30

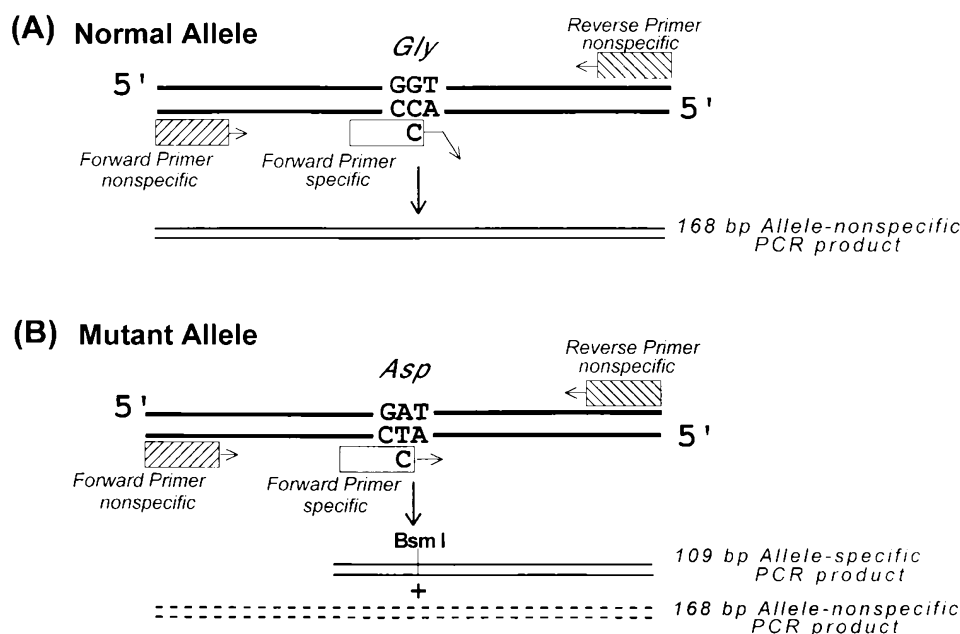

Fig. 1. Strategy for PCR amplification of specific alleles (PASA) with competitive priming of DNA template from a heterozygous subject for FH-Palermo-1 mutation. Panel A: The PCR amplification of normal allele gives a 168 bp allele-nonspecific product originating from the nonspecific couple of primers flanking the exon 11. The allele-specific forward primer mismatches, at its 3' end, to the base subject to mutation at codon 528 (encoding glycine). This C/C mismatch inhibits the annealing of specific primer and the amplification of DNA sequence comprised between this forward primer and the reverse nonspecific primer. Panel B: The PCR amplification of FH-Palermo-1 allele will generate prevalingly a 109 bp allele-specific product that originates from the couple forward allele-specific and reverse nonspecific primers. In this case the C/T mismatch between 3' terminus of allele-specific primer and the mutated base at codon 528 (now encoding aspartic acid) does not inhibit the annealing of this primer and the successive amplification of the sense strand. This specific amplification product of 109 bp is characterized by the presence of a Bsm I restriction site which may split it into 83 and 26 bp fragments. The imbalance between the allele-specific and the nonspecific forward primers (see Results and Discussion) determines a competitive advantage of allele-specific product over the 168 bp allele-nonspecific product (which is represented by dotted lines).

cycles, each consisting of 94°C for 30 sec, 58°C for 30 sec and 72°C for 1 min, and a final extension at 72°C for 8 min, in a Model 2400 Thermal Cycler (Perkin-Elmer, Norwalk, CT).

The PASA with competitive priming was carried out exactly as described above, apart from the fact that the amplification mixture also contained 2.5 pmol of the forward primer allele-nonspecific (5'-CAG CTA TTC TCT GTC CTC CCA CCA G-3').

After PCR, 12 µL of the amplification product was mixed with 3 µL of a gel loading buffer (containing sucrose and bromophenol blue) and electrophoresed on 12% polyacrylamide gel (7 × 10 cm) for about 40 min at 20 V/cm. The bands were stained with ethidium bromide and visualized with a UV transilluminator.

The samples that gave the allele-specific band were further verified by digesting 15 µL of amplification product with 2 U of Bsm I restriction endonuclease (Boehringer Mannheim Italia, Monza, Italy) in a total volume of 20 µL buffered with the specific Sure-cut buffer H (Boehringer Mannheim Italia) for 2 h at 65°C.

Finally, exon 11 of samples that gave the allele-specific band was submitted to DNA sequencing with a method previously described (13). The primers used to sequence both strands were those described by Hobbs et al. (12).

RESULTS AND DISCUSSION

The amplification of part of exon 11 with the couple allele-specific (forward) and allele nonspecific (reverse) primers under the conditions described here for PASA test gave an intense and clean band of 109 bp with samples containing the FH-Palermo-1 allele. Amplification of samples from either control subjects or patients with other point mutations did not give any amplification band. This is well evident in the electrophoresis reported in Fig. 2. This figure also demonstrated that the PASA test is sensitive enough to allow the detection of one positive heterozygous sample, when mixed with equal amounts of DNA from each of the four negative samples analyzed on the same plate (i.e., pooling 1 + 4 with same DNA amount). Tests performed with sequential dilution of the positive template mixed with normal DNA indicated that

this method gives a clear specific band of amplification up to six parts of normal DNA mixed with one part of positive DNA. Thereafter, the intensity of specific band fades to the point of being scarcely detectable in a 1 + 11 pool (results not shown).

Though the PASA test containing only the specific couple of primers appeared specific and sensitive enough to be used for screening purposes, we also examined the results obtainable with the addition to the PCR reaction mixture of a further allele-nonspecific forward primer that, in combination with the reverse nonspecific primer, allows the amplification of the entire exon 11 (i.e., it amplifies a DNA sequence encompassing that involved by allele-specific amplification). Actually, the two forward primers, in combination with the same reverse primer, will form two couples of primers, one nonspecific that generates a constant band (168 bp) present with both normal and mutant alleles and the other allele-specific that amplifies only the FH-Palermo-1 allele (109 bp) in competition with the nonspecific couple. For this reason the strategy was named 'competitive PASA'. We found that the generation of a constant band (168 bp) was very useful as an internal control for the technical success of the PCR (this prevents a sample not amplified by PCR from being considered negative for FH-Palermo-1 mutation) and, as a rule, allowed us to distinguish whether a positive sample was derived from a subject heterozygous or homozygous for the FH-Palermo-1 mutation. Results reported in Fig. 3 (left panel) indicate that the conditions of equilibrium between specific and nonspecific priming were reached when the allele-specific primer was in a ratio 1:4 with the nonspecific forward primer. In amplifications with a higher proportion of nonspecific forward primer, the nonspecific band was more intense (i.e., the nonspecific amplification prevailed over the specific amplification). In amplifications with a lower proportion of nonspecific forward primer, we obtained only a light band at 168 bp and an absolute discrimination between homozygous and heterozygous patients (results not shown).

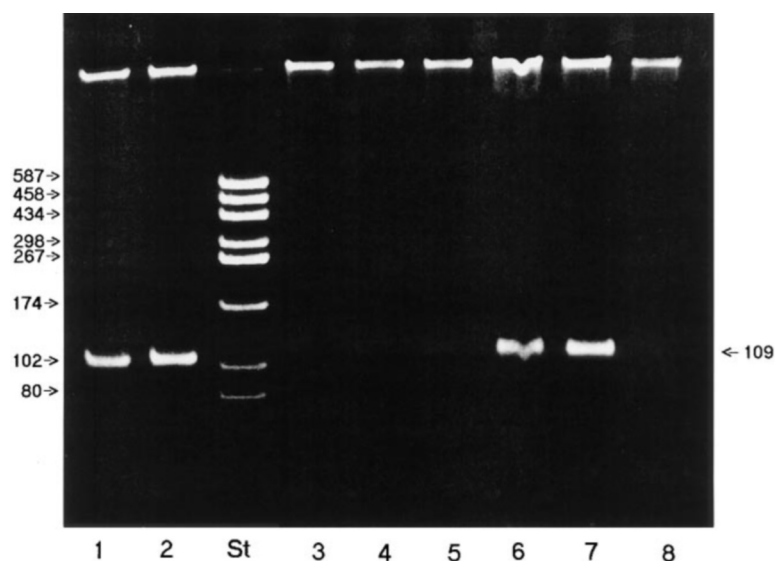

Fig. 2. Separation of PCR products obtained with the couple of primers allowing the allele-specific amplification by 12% polyacrylamide gel electrophoresis. Lanes 1 and 2: probands 70 and 89, positive for FH-Palermo-1 mutation; lane St: molecular size marker (pUC18 DNA digested with Hae III. The length of each fragment is reported on the left side of the photo); lanes 3, 4, and 5: probands A895, B274, and C128, found negative for FH-Palermo-1; lane 6: pool of one positive with four negative samples (equal amounts of DNA from each sample); lane 7: subject known to be a heterozygous carrier of FH-Palermo-1 mutation; lane 8: healthy control subject.

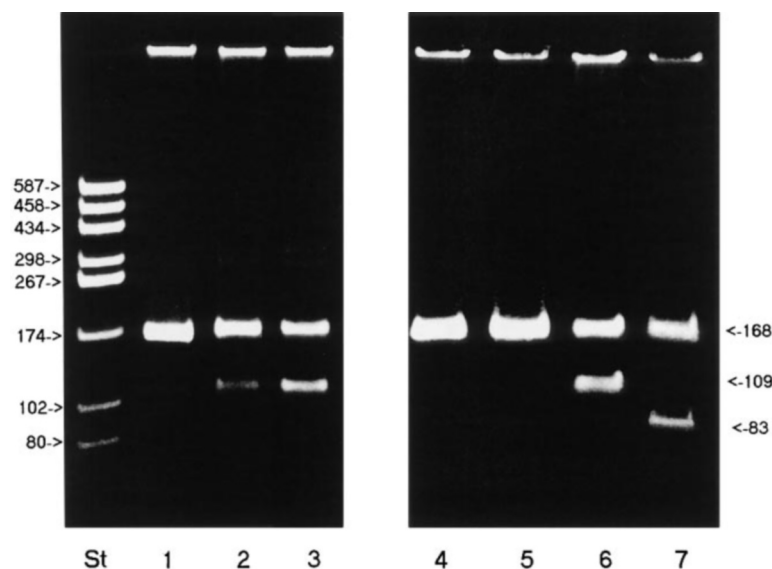

Fig. 3. Left panel. Separation of PCR products obtained under different conditions of competitive priming by 12% polyacrylamide gel electrophoresis. Lane St: molecular size marker (pUC18 DNA digested with Hae III; the length of each fragment is reported on the left side of the photo); lane 1: amplification of a heterozygous DNA template with 10 pmol each of the three primers; lane 2: same sample, amplified with 10 pmol each of forward allele-specific and reverse nonspecific primer, plus 5 pmol of forward allele-nonspecific primer; lane 3: same sample, amplified with 10 pmol each of allele-specific and reverse primer, plus 2.5 pmol of forward allele-nonspecific primer. Right panel. Characterization of Bsm I restriction site in PASA products by 12% polyacrylamide gel electrophoresis. lane 4: amplification of a heterozygous DNA template with the nonspecific primers only; lane 5: digestion of product of amplification of previous lane with 2U of Bsm I for 2 h at 65°C; lane 6: amplification of a heterozygous DNA template under conditions of competitive priming, as described in Materials and Methods; lane 7: the same amplification product after digestion with 2U of Bsm I for 2 h at 65°C.

Finally, we demonstrated (Fig. 3, right panel) that the product of allele-specific amplification, but not the non-specific product, is easily digested by Bsm I restriction endonuclease. This allows us to distinguish a genuine specific amplification product of FH-Palermo-1 allele from either a spurious amplification or a product derived from amplification of some still unknown complex mutation (i.e., deletions, insertions, rearrangements) that might affect the same area of the LDL-R gene. However, there remains the remote possibility that a different point mutation at the same base, such as C → A or C → G, may give the specific amplification product with the same Bsm I restriction pattern. For this reason it is strongly suggested that samples found positive to the PASA test should be definitely confirmed by sequence analysis.

This PASA test was used to screen 136 DNA samples of FH heterozygous patients from different parts of Italy for the FH-Palermo-1 allele. This test evidenced the presence of the mutation in seven apparently unrelated subjects

(Table 1), i.e., the allele represented roughly 5.1% of mutations causing FH in our national sampling. However, this proportion rose to 22.6% when expressed in relation to patients whose origins were from western Sicily or areas close to Naples, the only places where the mutation was found. The simplicity of this test should allow us to extend this investigation over a large number of southern probands. It is worth noting that all the samples positive at PASA test were confirmed to be genuine carriers of the FH-Palermo-1 allele by means of sequence analysis of exon 11 of LDL-R gene.

This work was supported by a grant from research project "Prevenzione dei fattori di rischio della salute materno-infantile", Istituto Superiore di Sanità, D. Leg.vo del 30.12.1992, n. 502.

Manuscript received 26 September 1997 and in revised form 16 December 1997.

TABLE 1. Clinical features of the index case of each family carrying the Gly₅₂₈ → Asp mutation

Family	Index Case	Sex	Age	LDL-CH ^a	Tendon Xantom.	Arcus Corneal	C.V.I. ^b	No. Hetero. per Family ^c	Geographic Origin
			yr	mmol/L					
1	C.F.	F	45	8.51	+	-	-	4	W. Sicily
2	S.M.	F	38	7.27	+	-	-	3	S. Italy
3	D.F.	M	45	7.63	+	-	M.I.	4	S. Italy
4	T.C.	F	55	8.66	+	+	-	2	S. Italy
5	C.A.	F	38	8.76	-	-	M.I.	10	S. Italy
6	N.G.	M	45	6.69	+	+	3VCAD	4	S. Italy
7	D.M.	M	44	8.71	+	-	-	4	S. Italy

^aLDL-CH: low density lipoprotein cholesterol level.

^bC.V.I.: cardiovascular involvement; M.I.: myocardial infarction; 3VCAD: three vessel coronary artery disease, with by-pass.

^cNumber of heterozygous carriers for each family. The mean ± SEM LDL-CH level from these subjects (n = 31), adjusted for age and gender, was 7.70 ± 0.22 mmol/L.

REFERENCES

1. Yap, E. P. H., and J. O'D. McGee. 1994. Detection of mutations by PCR. *In* PCR Technology, Current Innovations. H. G. Griffin and A. M. Griffin, editors. CRC Press, Boca Raton, FL. 107–120.
2. Doyle, K. 1996. Restriction enzymes. *In* The Source of Discovery—Protocols and Application Guide. 3rd edition. Ken Doyle, editor. Promega Corporation, Madison, WI. 3–24.
3. Sarkar, G., J. Cassady, C. D. K. Bottema, and S. S. Sommer. 1990. Characterization of polymerase chain amplification of specific alleles. *Anal. Biochem.* **186**: 64–68.
4. Okayama, H., D. T. Curiel, M. L. Brantly, M. D. Holmes, and R. G. Crystal. 1989. Rapid nonradioactive detection of mutations in the human genome by allele-specific amplification. *J. Lab. Clin. Med.* **114**: 105–113.
5. Wu, D. Y., L. Ugozzoli, B. K. Pal, and R. B. Wallace. 1989. Allele-specific enzymatic amplification of B-globulin genomic DNA for diagnosis of sickle cell anemia. *Proc. Natl. Acad. Sci. USA.* **86**: 2757–2760.
6. Newton, C. R., A. Graham, L. E. Heptinstall, S. J. Powell, C. Summers, N. Kaisheker, J. C. Smith, and A. F. Markham. 1989. Analysis of any point mutation in DNA: the amplification–refractory mutation system (ARMS). *Nucleic Acids Res.* **17**: 2503–2516.
7. Kwok, S., D. E. Kellog, N. McKinney, D. Spasic, L. Goda, C. Levenson, and J. J. Sninsky. 1990. Effects of primer template mismatches on the polymerase chain reaction: human immunodeficiency virus type I model studies. *Nucleic Acids Res.* **18**: 999–1005.
8. Bottema, C. D. K., G. Sarkar, J. D. Cassady, S. Ii, C. M. Dutton, and S. S. Sommer. 1993. Polymerase chain reaction amplification of specific alleles: a general method of detection of mutations, polymorphisms, and haplotypes. *Methods Enzymol.* **218**: 388–402.
9. Zhu, K. Y., and J. M. Clark. 1996. Addition of a competitive primer can dramatically improve the specificity of PCR amplification of specific alleles. *BioTechniques.* **21**: 586–590.
10. Hobbs, H. H., D. W. Russel, M. S. Brown, and J. L. Goldstein. 1990. The LDL receptor locus and familial hypercholesterolemia: mutational analysis of a membrane protein. *Annu. Rev. Genet.* **24**: 133–170.
11. Sambrook, J., E. F. Fritsch, and T. Maniatis. 1989. Molecular Cloning. A Laboratory Manual. 2nd edition. Cold Spring Harbor Laboratory Press, Cold Spring Harbor, NY.
12. Hobbs, H. H., M. S. Brown, and J. L. Goldstein. 1992. Molecular genetics of the LDL receptor gene in familial hypercholesterolemia. *Hum. Mutat.* **1**: 445–466.
13. Bertolini, S., N. Lelli, D. A. Coviello, M. Ghisellini, P. Masturzo, R. Tiozzo, N. Elicio, A. Gaddi, and S. Calandra. 1992. A large deletion in the LDL receptor gene—the cause of familial hypercholesterolemia in three Italian families: a study that dates back to the 17th century (FH-Pavia). *Am. J. Hum. Genet.* **51**: 123–134.