



AALBORG UNIVERSITY
DENMARK

Aalborg Universitet

Multi-Year PV Generation Planning Incorporating Power Electronics Impacts in Sizing Decisions

Sandelic, Monika; Sangwongwanich, Ariya; Peyghami, Saeed; Blaabjerg, Frede

Published in:
2023 IEEE Power & Energy Society General Meeting (PESGM)

DOI (link to publication from Publisher):
[10.1109/PESGM52003.2023.10252615](https://doi.org/10.1109/PESGM52003.2023.10252615)

Publication date:
2023

Document Version
Accepted author manuscript, peer reviewed version

[Link to publication from Aalborg University](#)

Citation for published version (APA):
Sandelic, M., Sangwongwanich, A., Peyghami, S., & Blaabjerg, F. (2023). Multi-Year PV Generation Planning Incorporating Power Electronics Impacts in Sizing Decisions. In *2023 IEEE Power & Energy Society General Meeting (PESGM)* (pp. 1-5) <https://doi.org/10.1109/PESGM52003.2023.10252615>

General rights

Copyright and moral rights for the publications made accessible in the public portal are retained by the authors and/or other copyright owners and it is a condition of accessing publications that users recognise and abide by the legal requirements associated with these rights.

- Users may download and print one copy of any publication from the public portal for the purpose of private study or research.
- You may not further distribute the material or use it for any profit-making activity or commercial gain
- You may freely distribute the URL identifying the publication in the public portal -

Take down policy

If you believe that this document breaches copyright please contact us at vbn@aub.aau.dk providing details, and we will remove access to the work immediately and investigate your claim.

Multi-Year PV Generation Planning Incorporating Power Electronics Impacts in Sizing Decisions

Monika Sandelic, Ariya Sangwongwanich, Saeed Peyghami, Frede Blaabjerg
AAU Energy, Aalborg University, Aalborg DK-9220, Denmark
mon@energy.aau.dk, ars@energy.aau.dk, sap@energy.aau.dk, fbl@energy.aau.dk

Abstract—Power electronics reliability can have a significant impact on the system reliability and cost, especially when a high installation rate of the renewable energy-based units is present in the system. Therefore, the power electronics reliability impact on the optimum system design needs to be included in the generation planning. However, current long-term planning methods do not include this impact in the decision making process. In this paper, a generation planning procedure which incorporates power electronics reliability in the sizing of generation units and power electronics over long-term planning horizon is presented. The case study results show that the size and installation time of the generation units and power electronics are optimized to reduce power electronics reliability-induced costs.

Index Terms—Long-term generation planning, power electronics, reliability, power system design, dynamic programming

I. INTRODUCTION

Photovoltaic (PV) systems have been an important contributing technology in climate change fight and achieving sustainable future. It is estimated that PV systems power more than 20 million homes in the U.S. solely, as the PV installation capacity reached 130.9 GW in 2022 [1].

PV system installation requires power electronics interface for a connection to the grid or to supply the load. Current field experience suggests that power electronics is subjected to frequent failure due to wear-out. It is reported that inverter failures have significantly higher frequency of failure (more than 50%) than any other unit in the PV system [2]. Moreover, they have one of the highest energy and power impact on the system. These challenges become more pronounced when the PV systems are part of a larger renewable energy-based, power electronics-interfaced system, as one shown in Fig. 1. For example, PV systems are often the main source of energy in the islanded microgrids which cannot rely on the power supply from the main grid. Unforeseen outages due to the power electronics failure can have serious reliability and cost implications [3]. To avoid such scenarios, power electronics reliability concerns need to be addressed in the long-term system planning [4]. In fact, it is necessary to plan for the sufficient generation capacity, as well as to include the power electronics reliability into decision making process.

However, the state-of-the art research is focused on the optimum sizing and siting of PV units to assure certain power system reliability and cost objectives [6]–[8]. For example, in [6], a multi-objective optimization procedure for planning of a residential PV-based microgrid is proposed. The study investigated the influence of different objectives, e.g., self

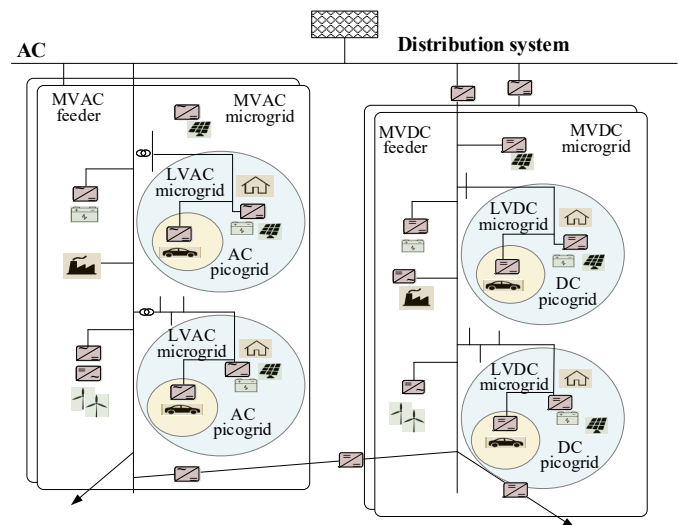

Fig. 1. Structure of the modern power electronics-based power system [5].

consumption rate, payback time and net load variance on the optimum planning solution. Furthermore, the uncertainty of PV generation is considered for optimum PV sizing in [7] and [9]. However, in all of the aforementioned research [6]–[9], the power electronics lifetime and reliability impacts to long-term planning are omitted.

In [10], the need for changing the design guidelines is addressed. The study concluded that the planning tools in the future need to incorporate, among others, power electronics aspects. In fact, it is pointed out that such changes are vital to assure accurate and informed design decision, especially when considering a higher penetration level and number of PV units. Hence, a method for multi-year PV generation planning that incorporates power electronics reliability impacts in the sizing decisions is proposed. The method determines the size of the generation units and the connected power electronics based on the knowledge of power electronics reliability. The main benefits of the method include a more realistic evaluation of the reliability and cost of the planned system. Former is achieved by including the evaluated power electronics failures due to wear-out in the decision making process. This information can be used to plan for a more cost-effective operation and maintenance strategies. Latter is achieved by including the power electronics replacement cost in the total system cost.

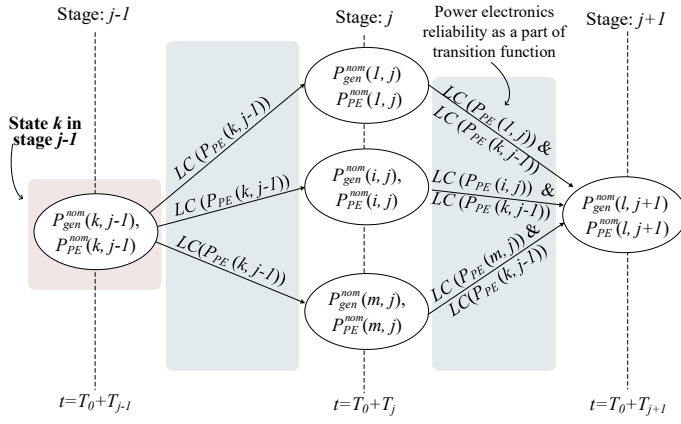

Fig. 2. Dynamic programming-based approach to multi-year generation planning with included power electronics reliability into decision-making process. Time horizon is divided into stages, while the states are the nominal power of the PV arrays P_{gen}^{nom} and the PV inverters P_{PE}^{nom} . Transition function includes lifetime consumption LC of the inverter.

The rest of the paper is organized as follows. In Section II, the multi-year generation planning procedure which incorporates power electronics reliability is presented. This is followed by a case study presented in Section III. Finally, the concluding remarks are given in Section IV.

II. GENERATION PLANNING PROCEDURE

The generation planning procedure is developed with the aim of sizing the system under consideration of power electronics reliability. The input to the planning procedure is the load demand P_{load} and its rate of the increase over the planning horizon T_{PH} . The output of the procedure are the nominal power of the PV arrays P_{gen}^{nom} and the nominal size of the PV inverters P_{PE}^{nom} , as well as their installation and replacement times. The sizes are determined to minimize the total cost of the system C_{sys} over T_{PH} . The important aspects in the decision-making procedure are the lifetime and the reliability of the power electronics units. Power electronics lifetime is determined by the operating and environmental conditions. During each year in service, the power electronics lifetime is consumed. Over a period of several years, the lifetime consumption (LC) is accumulated and leads to the unit failure due to wear-out. This results with unit replacement, which has impact on the system reliability and adds to the overall cost. To plan the system with a high installation rate of power electronics in an optimum way, this reliability aspect is included in the sizing procedure and accounted for each installed unit and each planned year of operation.

A. Optimization Space Definition

The generation planning model is developed as an optimization problem which is solved by means of dynamic programming (DP). Its principles are used as a basis to which additional features are added to enable power electronics reliability evaluation. DP method is suitable for the optimization of variables over time by dividing the optimization problem into

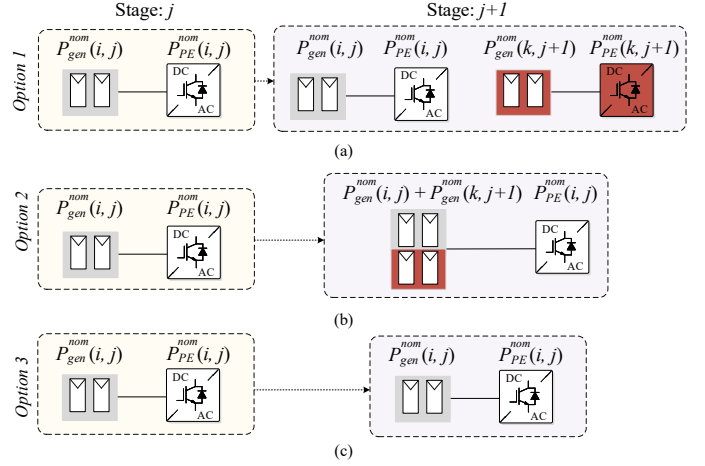

Fig. 3. Basis for definition of the possible states within DP framework: (a) a new PV array and inverter are added in stage $j+1$, (b) additional PV arrays are added to the already existing PV installed in the stage j , and (c) neither new PV arrays are added to the existing units nor new PV array and PV inverter are installed.

a series of smaller problems. The optimum solution is found in a recursive manner by finding the optimum solutions of the smaller problems [11]. The main principles of the DP include dividing the optimization problem into stages and states, as shown in Fig. 2. Stages represent the discrete time instances for which optimum solution needs to be found. In case of PV system generation planning, the stages represent each year in the planning horizon T_{PH} . States represent the possible outcomes of the optimization variable. In this study, they are defined as the nominal power of the PV arrays P_{gen}^{nom} and the PV inverters P_{PE}^{nom} .

In each stage, there are several combinations of PV arrays and inverter sizes that can define a state. The first option allows both P_{gen}^{nom} and P_{PE}^{nom} to be higher than zero. In this case, a new PV arrays and PV inverter are installed in the system at the stage j . In the second option, P_{gen}^{nom} is greater than zero, while P_{PE}^{nom} equals zero. This refers that the additional PV arrays are added to the already existing PV array installed before the stage j . Several states with a combination of the different values of the two variables can be defined to cover the first two options. Those combinations are defined based on the system requirements and the feasible PV arrays and inverter sizes. For example, they can be defined as the combinations of the different percentages of the nominal power required for the system. There is no restriction in the number of the possible states. However, a larger number of states can increase the complexity of the optimization problem. In the last option, both P_{gen}^{nom} and P_{PE}^{nom} are set to zero, which refers that no new installations are made in the stage j . The overview of the three options is illustrated in Fig. 3 for two consecutive stages.

The final part of the DP space is defined by the transition function. This function represents the transitions from one state in one stage to another state in the following stage. The main goal is to find the optimum state (size of PV arrays and

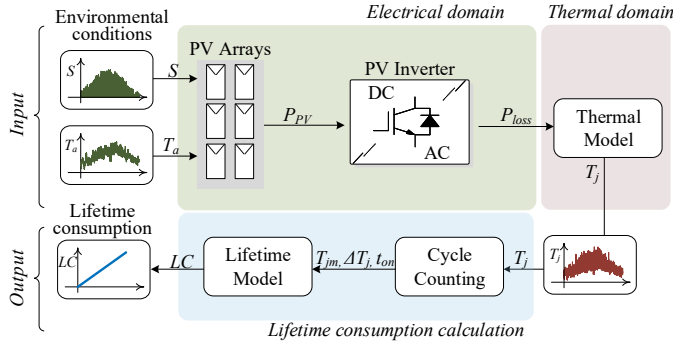

Fig. 4. Lifetime consumption LC procedure used as a part of the transition function in the generation planning procedure. The input are solar irradiance S and ambient temperature T_a . P_{PV} is PV arrays power output, P_{loss} is the converter loss, T_j is the junction temperature of Insulated-Gate Bipolar Transistor, T_{jm} and ΔT_j are mean and cycle amplitude of the junction temperature, while t_{on} is a cycle period.

inverter) of each stage (year) by minimizing system cost C_{sys} over planning horizon T_{PH} [12].

B. State Cost & Transition Cost

The overall cost of the system C_{sys} to be minimized consists of the state cost C_{state} and the transition cost C_{trans} . The mathematical expression of the system cost C_{sys} for reaching state i in the stage j is:

$$C_{sys}(i, j) = C_{state}(i, j) + C_{trans}(i, j) + C_{sys}^{opt}(j - 1) \quad (1)$$

where $C_{sys}^{opt}(j - 1)$ is the optimum system cost up to the stage j . The state cost C_{state} is associated with the capital cost of the PV array and PV inverter which represent the i -th state:

$$C_{state}(i, j) = C_{cap}^{gen} \times P_{gen}^{nom}(i, j) + C_{cap}^{PE} \times P_{PE}^{nom}(i, j) \quad (2)$$

where C_{cap}^{gen} and C_{cap}^{PE} are the cost of PV arrays and the cost of PV inverter, respectively in USD/kW.

Transition cost C_{tran} consists of three cost components. The first two costs account for the transition from state i in a stage j to state k in stage $j + 1$. Those are the operation & maintenance (O&M) cost $C_{om}(i, j)$ and the cost of power electronics reliability $C_{rel}^{PE}(i, j)$. The third cost accounts for C_{om} and C_{rel}^{PE} over the whole optimization period up to the stage $j + 1$. The mathematical expressions for the transition cost and its components are provided in (3)-(8).

$$C_{trans}(i, j) = C_{om}(i, j) + C_{rel}^{PE}(i, j) + C_{TS}(i, j) \quad (3)$$

$$C_{om}(i, j) = C_{om}^{gen} \times P_{gen}^{nom}(i, j) \quad (4)$$

where C_{om}^{gen} is O&M cost in USD/kW.

C. Power Electronics Reliability Cost

The cost of power electronics reliability C_{rel}^{PE} accounts for the LC accumulation of the PV inverter:

$$C_{rel}^{PE}(i, j) = C_{cap}^{PE} \times P_{PE}^{nom}(i, j) \times LC(P_{PE}^{nom}(i, j)) \quad (5)$$

where $LC(P_{PE}^{nom}(i, j))$ is the lifetime consumption of the PV inverter $P_{PE}^{nom}(i, j)$ for a one-year operation between two

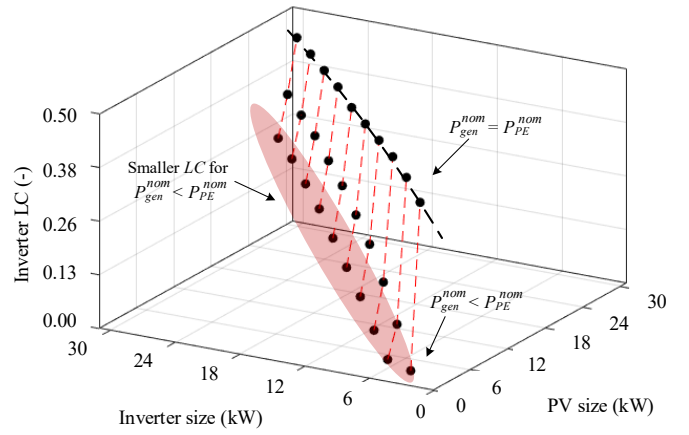

Fig. 5. Impact of the PV array size P_{gen}^{nom} and the inverter size P_{PE}^{nom} on the yearly lifetime consumption LC of the inverter.

consecutive stages j and $j + 1$. LC value is determined by using the mission profile, physics-of-failure, reliability-based modeling of power electronics [13]. As a part of this process, the input operating conditions of the power electronics unit need to be translated to the thermal loading, as shown in Fig. 4. The relevant stress information are then extracted from the thermal loading profile to determine the number of cycles to failure N_f [14], [15]:

$$N_f = K \cdot (\Delta T_j)^{\beta_1} \cdot e^{\frac{\beta_2}{T_{jm} + 273}} \cdot (t_{on})^{\beta_3} \cdot I^{\beta_4} \cdot V^{\beta_5} \cdot D^{\beta_6} \quad (6)$$

where ΔT_j the cycle amplitude, T_{jm} is the mean junction temperature, and t_{on} is the cycle period.

To determine the lifetime consumption LC , the number of cycles for a certain set of operating conditions n_i is divided by the number of cycles to failure N_f :

$$LC = \sum_i \frac{n_i}{N_{fi}} \quad (7)$$

LC is a value in the 0 to 1 interval, with LC being zero at the beginning of life, i.e., when the new PV inverter is installed. Once the LC accumulates to one, the PV inverter has reached its end-of-life. The overview of the LC for a one-year mission profile based on a combination of different PV arrays and inverter sizes is shown in Fig. 5.

D. Transition Stack

The third part of the transition cost consists of the accumulated C_{om} and C_{rel}^{PE} of all the installed units up to the stage j . When defining this cost, it is necessary to consider only the cost of the units which are a part of the optimum path up to the stage j . Therefore, a transition stack is defined to save the information about the states of the optimum path and the associated LC . It is dynamically adjusted to account for the increase in LC for the PV inverters to which additional PV

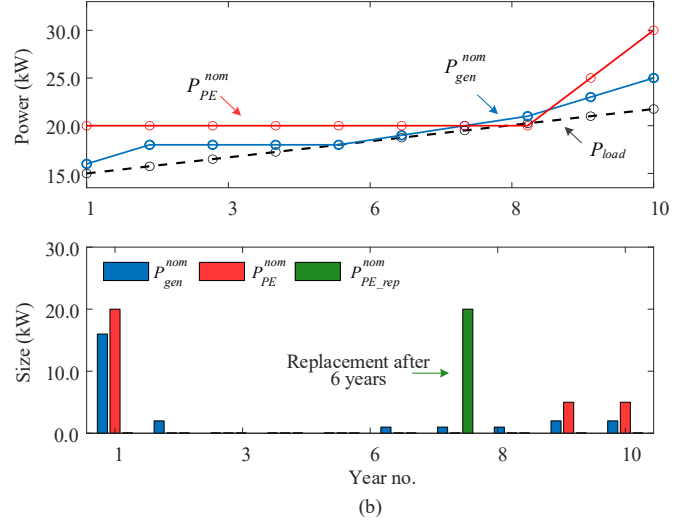
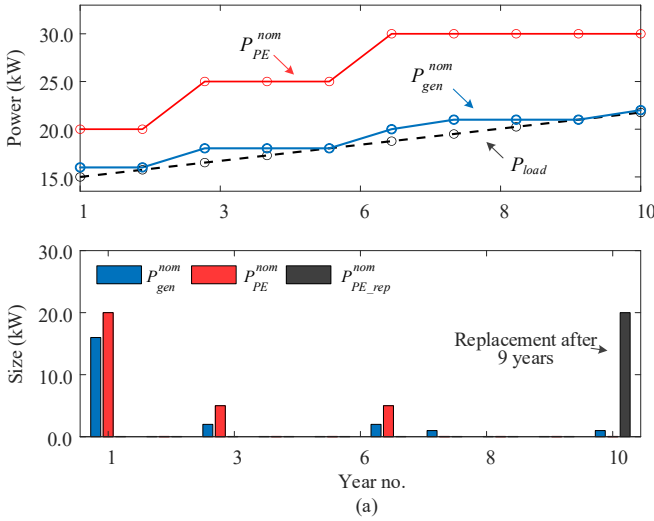

Fig. 6. Case study results: Optimum size of PV arrays P_{gen}^{nom} and PV inverters P_{PE}^{nom} over the planning horizon T_{PH} of 10 years for the input load demand P_{load} : (a) with included power electronics reliability into decision-making process, and (b) without included power electronics reliability.

arrays are added throughout time (Fig. 3(b)). Its mathematical expression is provided in (8).

$$C_{TS}(i, j) = \sum_{n=1}^j \sum_{t=T_i(n)}^j C_{rel}^{PE}(i, j) + C_{om}(i, j) \quad (8)$$

where T_i indicates the installation time of a specific unit.

E. Optimization Constraints

Two constraints are defined to determine the feasible states of each stage. The first constraint relates to the maximum installation size of the PV arrays connected to a single inverter:

$$P_{gen}^{nom}(i, j) \leq 1.5 \times P_{PE}^{nom}(i, j) \quad (9)$$

The installation size considers a single PV arrays installation, as well as the total PV arrays installation, if the additional arrays are added over time. The second constraint relates to the sufficient PV system generation capacity to cover P_{load} :

$$P_{gen}^{inst}(i, j) + P_{gen}^{nom}(i, j) \geq P_{load}(j) \quad (10)$$

where $P_{gen}^{inst}(i, j)$ is the optimum generation up to stage j .

III. CASE STUDY

PV systems for residential applications is studied, where PV arrays and power electronics are modeled as in [15]. The cost information are based on [16]. The planning horizon T_{PH} is 10 years. This horizon is chosen to illustrate and analyse the impact of the sizing decisions under the influence of power electronics reliability. The initial load demand $P_{load}(T_0)$ equals 15 kW and it is assumed that it grows linearly 5%/year. The available PV inverter and PV array values are $P_{load}(T_0) \times \{0.33, 0.67, \dots, 1.66\}$ and $P_{PE}^{nom} \times \{0.5, 0.6, \dots, 1.5\}$, respectively. The input high time resolution profiles of the environmental conditions used for the estimation of PV inverters LC are taken from [15]. It is assumed that the yearly profiles do not change over T_{PH} .

A. Impact of Power Electronics Reliability on Sizing Results

Optimum sizing is investigated for two cases; with (Case I) and without (Case II) power electronics reliability included in the sizing decisions. The optimum sizing results are shown in Fig. 6. In both cases, the optimum sizes of the installed PV inverters P_{PE}^{nom} are the same, but their installation times differ. On the contrary, the PV array sizes P_{gen}^{nom} do not match throughout T_{PH} . The results suggest that the PV array installation times have direct impact on the PV inverters lifetime. For example, in Case II, the additional PV arrays are added to the already existing PV system installed in the first year. Those additional PV arrays increase the loading of the PV inverter and accelerate its wear-out. As a result, the PV inverter installed in the first year needs to be replaced earlier compared to Case I. Such situation is avoided in Case I, where the additional PV arrays are added to the units installed later in the planning horizon. Those units do not already have a high LC rate, which results in later replacements.

From the cost perspective, the cost of power electronics replacement C_{rel}^{PE} contributes less to overall cost of the system C_{sys} when power electronics reliability is included in the sizing decisions. This results with the 7% lower cost of the Case I. Similar results can be expected for the longer planning horizons, where the effect of power electronics reliability on the system can be even more pronounced. Nonetheless, economic analysis needs to be combined with the power system reliability requirements in the future. Such analysis can help to fully understand the connection between the reliability requirements and the cost saving opportunities in the power electronics-based systems.

B. Impact of Replacement Strategy on the System

The optimum sizing results from the previously investigated case (see Fig. 6(a)) are used to further investigate the power electronics reliability impact on the generation planning. Two

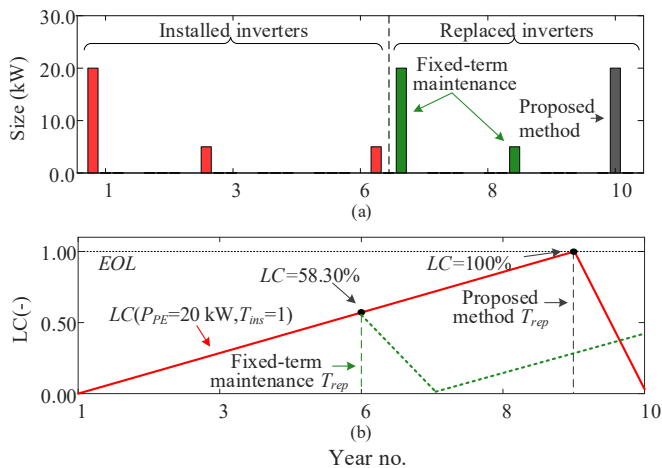

Fig. 7. Case study results: (a) Replacement time of the PV inverters based on the fixed-term maintenance and replacement due to wear-out included in the proposed generation planning method, and (b) Lifetime consumption LC of the PV inverter.

different replacement strategies are applied to the system. In Strategy I, the proposed method is used to replace the power electronics units when they reach end-of-life (EOL) due to wear-out failure. In Strategy II, the replacement of the units is based on the fixed intervals which correspond to the power system reliability requirements.

The results of the two replacement strategies are provided in Fig. 7(a). It is shown that Strategy I determines only one replacement, i.e., the replacement of the first installed PV inverter after 9 years in operation. In case of fixed-term maintenance (Strategy II), this inverter is replaced 4 years earlier. Moreover, the second installed PV inverter is replaced after 5 years in operation (i.e., being 8-th year in the planning horizon). On the example of the LC results shown in Fig. 7(b) of the first installed PV inverter, the impact of replacement strategy on the system is shown. LC results indicate that less than 60% of the lifetime is consumed in practice when the replacement due to fixed-term maintenance strategy takes place. This refers that the PV inverter lifetime is not fully utilized. However, from a power system perspective, PV inverter replacement assures a higher level of system reliability. Therefore, the proposed procedure should be combined with a detailed power system reliability requirements in the future. Such planning approach can be used for sizing of larger systems with various power electronics-based units and specific reliability requirements in the future.

IV. CONCLUSION

In this paper, a multi-year generation planning procedure which incorporates power electronics reliability impacts in the sizing decisions is presented. Case study results show that inclusion of the power electronics reliability does not only impact the optimum size and the installation time of the generation units but also the size and the replacement time of the power electronics unit. The proposed method can be used

as a part of the long-term planning procedure, where it can be combined with the main power system reliability aspects. In such way, an optimum design of the large systems with a high installation rate of the renewable energy-based, power electronics-interfaced units can be achieved for a suitable level of reliability and with the optimum cost.

ACKNOWLEDGMENT

This work was supported by the Reliable Power Electronic-Based Power System (REPEPS) project at the AAU Energy, Aalborg University as part of the Villum Investigator Program funded by the Villum Foundation.

REFERENCES

- [1] Solar Energy Industry Association (SEIA), "U.S. solar market insight," 2022. [Online]. Available: <https://www.seia.org/us-solar-market-insight>. Accessed: Nov. 16., 2022.
- [2] Kiwa, "Addressing the challenges of string inverter failures in solar PV systems," 2021. [Online]. Available: <https://www.kiwa.com/nl/en/>. Accessed: Jan. 5, 2022.
- [3] R. Wu and G. Sansavini, "Integrating reliability and resilience to support the transition from passive distribution grids to islanding microgrids," *Appl. Energy*, vol. 272, pp. 115 254–115 264, 2020.
- [4] M. Sandelic, S. Peyghami, A. Sangwongwanich, and F. Blaabjerg, "Reliability aspects in microgrid design and planning: Status and power electronics-induced challenges," *Renew. Sust. Energ. Rev.*, vol. 159, pp. 112 127–112 144, 2022.
- [5] S. Peyghami, P. Palensky, M. Fotuhi-Firuzabad, and F. Blaabjerg, "System-level design for reliability and maintenance scheduling in modern power electronic-based power systems," *IEEE Open Access J. Power Energy*, vol. 7, pp. 414–429, 2020.
- [6] Y. Kurdi, B. J. Alkhatatbeh, S. Asadi, and H. Jebelli, "A decision-making design framework for the integration of pv systems in the urban energy planning process," *Renew. Energy*, vol. 197, pp. 288–304, 2022.
- [7] M. Alhaider, L. Fan, and Z. Miao, "Benders decomposition for stochastic programming-based PV/battery/HVAC planning," in *Proc. of PESGM*, Boston, MA, USA, 2016, pp. 1–5.
- [8] S. Li, J. Zhu, Z. Chen, and T. Luo, "Optimal capacity planning based on energy sharing platform for virtual residential microgrid," in *Proc. of PESGM*, Montreal, QC, Canada, 2020, pp. 1–5.
- [9] S. Jung, J. Jeoung, H. Kang, and T. Hong, "Optimal planning of a rooftop PV system using GIS-based reinforcement learning," *Appl. Energy*, vol. 298, pp. 117 239–117 251, 2021.
- [10] J. W. Smith, R. Dugan, M. Rylander, and T. Key, "Advanced distribution planning tools for high penetration PV deployment," in *Proc. of PESGM*, San Diego, CA, USA, 2012, pp. 1–7.
- [11] Y. Li and J. Wu, "Optimum integration of solar energy with battery energy storage systems," *IEEE Trans. Eng. Manag.*, vol. 69, no. 3, pp. 697–707, 2022.
- [12] P. Zeng, H. Li, H. He, and S. Li, "Dynamic energy management of a microgrid using approximate dynamic programming and deep recurrent neural network learning," *IEEE Trans. Smart Grid*, vol. 10, no. 4, pp. 4435–4445, 2019.
- [13] A. Sangwongwanich, Y. Yang, D. Sera, and F. Blaabjerg, "Mission profile-oriented control for reliability and lifetime of photovoltaic inverters," *IEEE Trans. Ind. Appl.*, vol. 56, no. 1, pp. 601–610, 2020.
- [14] R. Bayerer, T. Herrmann, T. Licht, J. Lutz, and M. Feller, "Model for power cycling lifetime of IGBT modules - various factors influencing lifetime," in *Proc. of CIPS*, Nuremberg, Germany, 2008, pp. 1–6.
- [15] M. Sandelic, A. Sangwongwanich, S. Peyghami, and F. Blaabjerg, "Reliability modelling of power electronics with mission profile forecasting for long-term planning," in *Proc. of PEDG*, Kiel, Germany, 2022, pp. 1–6.
- [16] National Renewable Energy Laboratory (NREL), "U.S. Solar Photovoltaic System and Energy Storage Cost Benchmarks, With Minimum Sustainable Price Analysis: Q1 2022," Tech. Rep. No. NREL/TP-7A40-83586, 2022.