



Aalborg Universitet

AALBORG UNIVERSITY
DENMARK

An Intelligent Hybrid Fractional Order Controller for DC–DC Buck Converters Feeding Constant Power Loads

Sorouri, Hoda; Oshnoei, Soroush; Oshnoei, Arman; Blaabjerg, Frede; Teodorescu, Remus

Published in:
25th European Conference on Power Electronics and Applications-Aalborg, Denmark

Publication date:
2023

[Link to publication from Aalborg University](#)

Citation for published version (APA):

Sorouri, H., Oshnoei, S., Oshnoei, A., Blaabjerg, F., & Teodorescu, R. (2023). An Intelligent Hybrid Fractional Order Controller for DC–DC Buck Converters Feeding Constant Power Loads. In *25th European Conference on Power Electronics and Applications-Aalborg, Denmark*

General rights

Copyright and moral rights for the publications made accessible in the public portal are retained by the authors and/or other copyright owners and it is a condition of accessing publications that users recognise and abide by the legal requirements associated with these rights.

- Users may download and print one copy of any publication from the public portal for the purpose of private study or research.
- You may not further distribute the material or use it for any profit-making activity or commercial gain
- You may freely distribute the URL identifying the publication in the public portal -

Take down policy

If you believe that this document breaches copyright please contact us at vbn@aub.aau.dk providing details, and we will remove access to the work immediately and investigate your claim.

An Intelligent Hybrid Fractional Order Controller for DC–DC Buck Converters Feeding Constant Power Loads

1st Hoda Sorouri 2nd Soroush Oshnoei 3th Arman Oshnoei 4th Remus Teodorescu 5th Frede Blaabjerg
Aalborg University Aarhus University Aalborg University Aalborg University Aalborg University
Aalborg, Denmark Aarhus, Denmark Aalborg, Denmark Aalborg, Denmark Aalborg, Denmark
hoso@energy.aau.dk soroush_oshnoei@yahoo.com aros@energy.aau.dk ret@energy.aau.dk fbl@energy.aau.dk

Index Terms—Buck DC–DC converters, Fractional Order Controller, Artificial neural network, Constant power load.

Abstract—This paper presents an intelligent hybrid fractional order controller for regulating the output voltage of a DC-DC buck converter feeding constant power loads. The controller combines tilt integral derivative and fractional order proportional integral derivative controllers. An artificial neural network is used for online adaptation of the controller gains to avoid the dependence on the response of the converter control system on operating point conditions. Real-time simulations demonstrate the effectiveness of the proposed method in regulating the output voltage and mitigating the impact of varying power loads. The proposed controller outperforms a backstepping controller and a hybrid controller with constant gains.

I. INTRODUCTION

DC–DC converters are extensively utilized in DC microgrids to supply a constant dc voltage for storage and generation components. Buck, boost, and buck/boost are the three main DC–DC converters vital to many residential and industrial appliances [1]. However, these converters’ switching dynamics may cause the DC microgrids to behave nonlinearly. Therefore, regulating the output voltage can be a challenging duty. In this regard, achieving a suitable control approach for the DC–DC converters is essential to enhance transient and steady-state requirements in different operating conditions.

On the other hand, many fully controlled loads (e.g., inverter motor drives, power supply, etc. [2]) that act as constant power loads (CPLs) have a non-linear and destabilizing effect on the converters. The

cause of this instability is appropriately explained in previous research employing passivity-based analysis [3], eigenvalue analyses [4], and small-signal impedance-based analyses [5]. Several approaches have been suggested to alleviate the instability issue induced by the CPLs. From a physical perspective, the approaches can be separated into passive and active damping strategies. However, they require extra expenses and physical limitations. There are various control methods for voltage control of DC-DC converters, such as sliding mode control (SMC) [6], model predictive control (MPC) [7], and backstepping control [8]. In [6], the SMC is applied to DC-DC buck converters with CPL. The SMC’s fundamental flaw is that it is challenging to put limitations or regulate abstract quantities. To cover the mentioned drawbacks, the authors in [7] have used the MPC method to control a boost converter with CPL. However, this method demands a precise mathematical model, which is a complex and time-consuming duty. In [8], a backstepping control is proposed to control a DC-DC converter feeding a CPL. However, this method requires a massive on-line real-time computing process.

Fractional calculus has been broadly utilized in control systems, where fractional order integration and differentiation can be used in the controller. The modeling and control of power electronic systems using fractional calculus have grown significantly over the past decade [9], [10]. Recent years have seen a significant amount of study on tilt integral derivative (TID) and fractional order proportional integral derivative (FOPID) controllers for several DC-DC converters, grid-connected inverters, electrical drives, multi-level converters in wind energy applications, and microgrids [9]. Besides, setting the controller gains is a significant stage in designing the controller. Unsuitable gains

may impose instability problems on the control system of the converter. In this regard, many evolutionary optimization techniques are able to choose the optimal coefficients. For example, an artificial bee colony has been utilized in [11] to optimize the FOPID controller coefficients in a DC-DC boost converter. In this method, the objective function calculates the coefficients to minimize the difference between the reference and output voltage. The strength Pareto evolutionary algorithm is proposed in [12] as a multi-objective optimization method for designing optimal FOPID controllers for boost converters. Although evolutionary algorithms are superior to a random trial-and-error search considering the concepts of fitness pressure, variety, and heredity, these methods are too time-consuming. Moreover, variations in the operating point give rise to unsatisfactory controller performance.

This paper proposes an intelligent Hybrid Fractional Order controller to regulate the output voltage of a DC-DC buck converter supplying a CPL. The design of the hybrid controller is based on fusing the TID and FOPID controllers. An artificial neural network (ANN) is employed for the adaptive and optimal determination of the controller gains. The proposed strategy's key benefit is the ANN's online execution. By doing this, the gains are constantly updated in real-time, which avoids the dependence on the response of the converter control system under uncertainties and disturbances. Simulation results validate the efficacy of the suggested strategy in comparison with a backstepping controller and a Hybrid fractional order controller with constant gains.

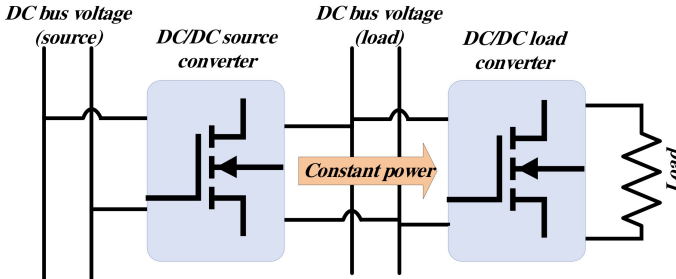

Fig. 1. Schematic of DC-DC converter with a resistive load.

II. MODEL OF A DC-DC BUCK CONVERTER WITH CPLs

Electric devices, such as DC-DC converters and electronic loads, especially in the power system distribution modules, behave as CPL in cases where this equipment is tightly controlled. Fig. 1 shows a DC-DC converter with a controlled voltage to feed a

resistive load. A circuit diagram of the interface DC-DC buck converter is shown in Fig. 1. The converter considers a buck converter using pulse-width modulation (PWM) that supplies a CPL and receives its power from renewable sources. The converter is controlled by the duty cycle u of the MOSFET so that the output voltage V_{CPL} stays stable. The CPL current is obtained as follows.

$$i_{CPL}(t) = \frac{P}{V_{CPL}(t)}; \quad \forall V_{CPL}(t) > \epsilon \quad (1)$$

where P is CPL's power, i_{CPL} is CPL's current, V_{CPL} is CPL's voltage, and epsilon has a small positive value. Generally, the state-space model is utilized to study and control DC-DC buck converters. Based on the average switching design [2], the simplified DC-DC buck converter model with CPL can be given as:

$$\frac{dx_1}{dt} = \frac{1}{L}[E \cdot u - x_2] \quad (2)$$

$$\frac{dx_2}{dt} = \frac{1}{C}[x_1 - \frac{P}{x_2}] \quad (3)$$

$$y = V_0 \quad (4)$$

where x_1 and x_2 are the average currents of the inductor i_L and the capacitor voltage V_C , respectively; C and L are the capacitor and inductor of the converter, respectively; and $u \in \{0, 1\}$ denotes the control input. More detail about modelling a DC-DC buck converter supplying a CPL can be found in [13].

III. DESIGN OF THE PROPOSED CONTROLLER

A. Fractional order controllers

The performance of the first-order controllers, such as I, PI, and PID controllers, may be significantly decreased under various system parameters and operating conditions, necessitating the introduction of flexible and robust controllers against these conditions. As a result, the idea of fractional order controllers (FOCs) has been presented. These controllers' basic concept is to expand integration and differentiation into integer-order terms to create a fractional-order (FO) operator. The FO operator is mathematically defined by the following equation:

$${}_a D_t^\beta = \begin{cases} \frac{d^\beta}{dt^\beta} & \beta > 0 \\ 1 & \beta = 0 \\ \int_a^t (d\tau)^\beta & \beta < 0 \end{cases} \quad (5)$$

Here, β shows the order of the fractional operator while a and t are the bounds of the operation. The order of the fractional operator is variable based on

the real number domain. The most definitions of the fractional integrals and derivatives, which cause to facilitate numerical evaluations and analysis, are the Grünwald-Letnikov definition (GLD), the Riemann-Liouville definition (RLD), and the Caputo definition (CD) [14]. This paper adapts the R-L definition method, details of which can be found in [15]. Besides, this paper employs the command robust d'ordre non-entier (CRONE) approximation, presented by Oustaloup, out of several other approximations. CRONE utilizes a recursive distribution of N poles and N zeros, conducting a transfer function during the predefined frequency range $[\omega_l, \omega_h]$ [16]. In the simulation process, $\omega_l = 0.01$ rad/s, $\omega_h = 100$ rad/s, and $N = 5$ are presumed.

$$H_f(s) = s^\beta = K \prod_{n=1}^N \frac{1 + (s/\omega_{z,n})}{1 + (s/\omega_{p,n})} \quad (6)$$

where K shows the tunable gain, $\omega_{z,n}$ and $\omega_{p,n}$ represent the zeroes and poles of $H_f(s)$, which are calculated as follows:

$$\omega_{z,l} = \omega_l \sqrt{n}, \quad (7)$$

$$\omega_{p,n} = \omega_{z,n} \tau, \quad n = 1, \dots, l \quad (8)$$

$$\omega_{z,n+1} = \omega_{p,n} \sqrt{n}, \quad n = 1, \dots, l-1 \quad (9)$$

where

$$\tau = \left(\frac{\omega_h}{\omega_l} \right)^{\varepsilon/N} \quad \sigma = \left(\frac{\omega_n}{\omega_l} \right)^{(1-\varepsilon/N)} \quad (10)$$

FOPID and TID controllers are two well-known FO controllers. Typically, the transfer functions of these controllers are given by (11) and (12), respectively [15].

$$H_{FOPID}(s) = K_P + \frac{K_I}{s^\lambda} + K_D s^\mu \quad (11)$$

$$H_{TID}(s) = K_T s^{-(1/n)} + \frac{K_I}{s} + K_D s \quad (12)$$

where K_I , K_P , K_D , and K_T show the tunable integral, proportional, derivative, and tilt coefficients, respectively. λ and μ are the FO operators of the integral and derivative terms in the FOPID controller, respectively. n indicates the FO operator of the tilt term in the TID controller. λ and μ are adjusted in the range of $(0, 1)$, and n is selected in $(2, 3)$. The proposed voltage controller is based on a hybrid FOC that combines the capabilities of a TID controller with those of a FOPID controller. The FO integral and derivative terms improve the system's stability and robustness as well as raise the controller response's speed. Therefore, compared to the TID controller, these parameters in the FOPID

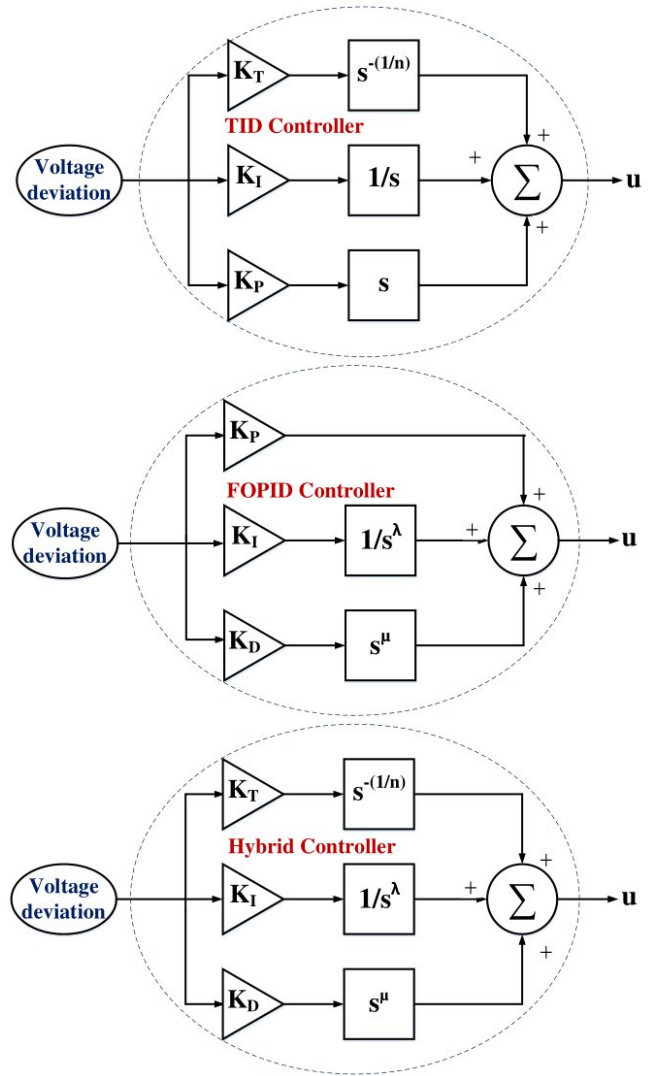

Fig. 2. Structure of FOPID, TID, and the proposed Hybrid controllers

controller have more degrees of freedoms. Moreover, as the tilt component of the TID controller has given this controller more degrees of freedom than the FOPID one, the proposed Hybrid controller takes advantage of both as follows:

$$H_{Hybrid} = K_T s^{-(1/n)} + K_I s^{-\lambda} + K_D s^\mu \quad (13)$$

Fig. 2 shows the structure of TID, FOPID, and Hybrid-based voltage controllers. It is clear from Eqs. 11-13, some parameters require to be adjusted optimally.

Remark I. Previous studies have mainly used evolutionary algorithms to adjust the parameters of the FOCs. However, these methods are too time-consuming. Moreover, variations in the operating point give rise to poor performance of the controllers. Accordingly, an

intelligent tuning strategy based on ANN is proposed in this study to provide an accurate online adaptation of the control parameters.

B. ANN-based intelligent tuning scheme

Generally, intelligent controllers can be used as supervisory tuners to enhance the performance of classic controllers in complex nonlinear power system models with uncertainties [8]. The neural network is among the most popular intelligent supervisory methods and it is successfully applied for online adjusting of PI controller coefficients. An ANN-based regulation scheme is used in this paper for online and fine-tuning of the Hybrid-based FO controller, which is used to regulate the output voltage of a dc/dc converter feeding a CPL. The ANN-based regulation scheme provides a smooth performance in transients. In developing the ANN-based regulation scheme, the deviation in the output voltage of the converter as well as its derivative used as inputs to the ANN. Fig. 4 shows how the ANN-based approach is used in the control system of the converter. The designed ANN comprises an input and an output layer with two hidden layers. The input layer of ANN contains ten linear neurons, and the hidden layers contain twenty nonlinear neurons. The nonlinear functions in the hidden layers can provide a smooth update of the neural network weights throughout the procedure. The output layer of ANN contains three linear neurons corresponding to the tilt, integral, and derivative gains of the Hybrid controller. Three scaling coefficients are also considered in the outputs of the ANN-based scheme. It should also be noted that for simplicity, the parameters λ and μ existing in the Hybrid-based FO controller are obtained through a trial-and-error process. The trial-and-error process was executed based on the designer's knowledge and experience with the control system and the permissible search space of the control command. Moreover, the back-propagation technique is used for the learning process, and the supervised feedback approach is used to update the ANN weights [17].

TABLE I
PARAMETERS OF THE TEST SYSTEM

Parameters	Values
Input voltage	$E = 80 \text{ V}$
Switching frequency	$f_r = 10 \text{ kHz}$
CPL(nominal)	$P_{CPL} = 120 \text{ W}$
Reference output voltage	$V_{CPL} = 24 \text{ V}$
Converter Inductance	$L = 2 \text{ mH}$
Converter Capacitance	$C = 1.2 \text{ mF}$

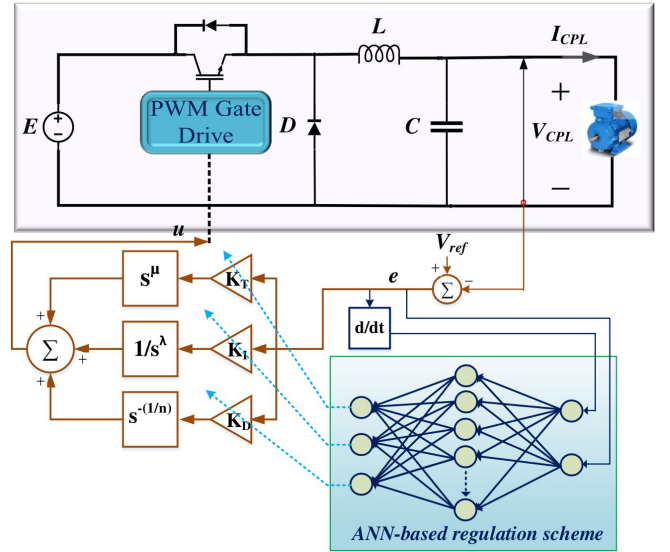

Fig. 3. Diagram of ANN-based Hybrid controller applied to a DC-DC converter

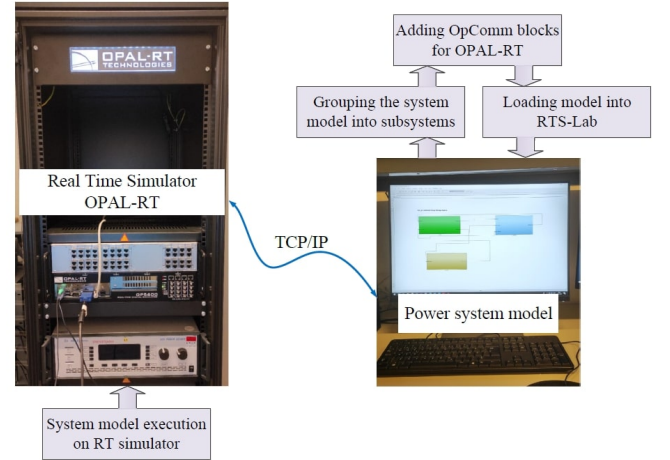

Fig. 4. Real-time experimental setup

IV. REAL-TIME SIMULATION RESULTS

In order to demonstrate the performance of the proposed control scheme in real-time, DC-DC Buck Converter feeding a CPL with the same architecture as shown in Fig. 2 is implemented in OPAL-RT real-time (RT) simulator. The parameters of the system are given in Table I. Fig.5 shows real-time experimental setup. The performance of the proposed ANN-based Hybrid controller is studied under two different scenarios, and compared with a backstepping controller [18] and a Hybrid controller with constant gains. In the Hybrid controller design without ANN, the control parameters are considered as $K_T = 10$, $K_I = 20$, and $K_D = 0.5$.

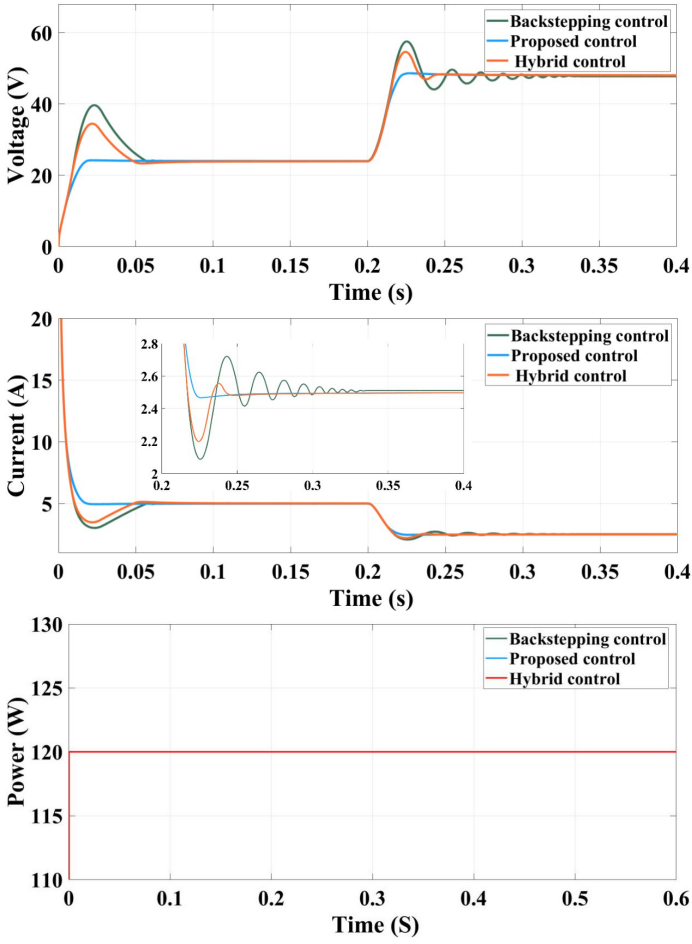

Fig. 5. Output Voltage and load current in Scenario 1

A. Scenario 1

In this scenario, the reference voltage is instantly changed to 48 V at $t = 0.2s$ while the reference voltage is set as 24 V when the CPL's power is applied as a constant value of $P = 120 W$. The output voltage and load current for different control methods are shown in Fig. 6. As it can be seen, the voltage reaches the reference value at an appropriate time without any overshoot, undershoot, or ripple in comparison to the backstepping controller and Hybrid controller with constant gains. A similar statement about the load current is valid, where it varies to deliver constant power. The generated gains by the ANN-based regulation scheme are presented in Fig. 7 in response to the applied reference voltage change. The figure indicates that the ANN approach regulates the control parameters of the converter controller in such a way that the least fluctuations are achieved in the dynamic responses.

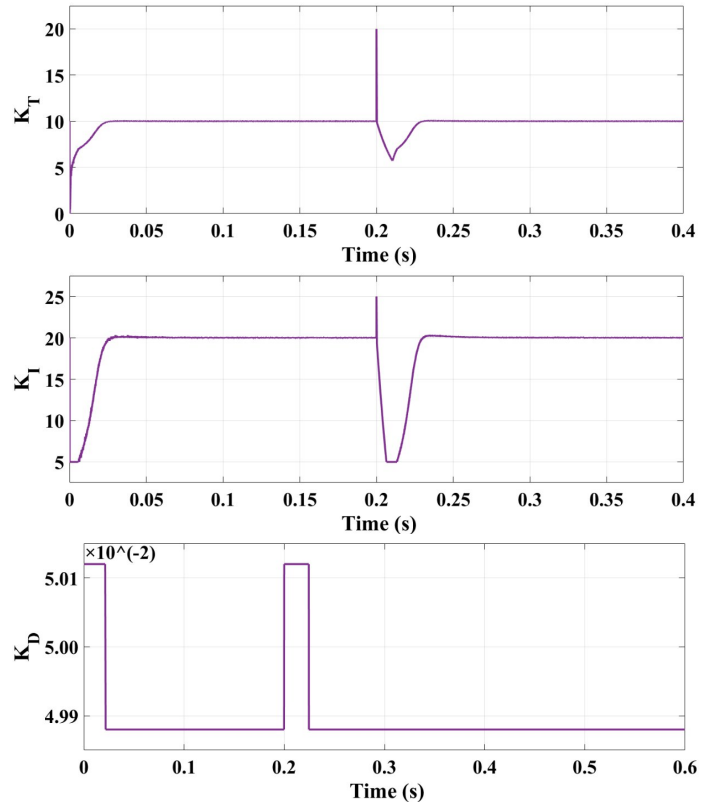

Fig. 6. Updated parameters of the Hybrid controller by ANN in scenario 1

B. Scenario 2

A CPL with time-varying power is imposed on the test system for robustness evaluation in a more challenging situation. It is assumed that the CPL's power suddenly decreases in $t = 0.2s$ from its nominal value ($P_{CPL} = 120 W$) to 20 W. Fig. 8 shows the ability of the proposed control scheme to mitigate the impact of the changes of P_{CPL} , where the achieved results are compared with backstepping and Hybrid without ANN techniques. According to this figure, it is clear that with the backstepping controller and hybrid controller can stabilize the system voltage, the proposed scheme improves the performance of the DC-DC converter as compared to the other approaches and keep the voltage on the exact value of the reference voltage. Moreover, the generated gains by ANN are shown in Fig. 9. As it can be seen, the ANN updates the gains online and dynamically during the transient state to achieve the least fluctuations in the dynamic responses.

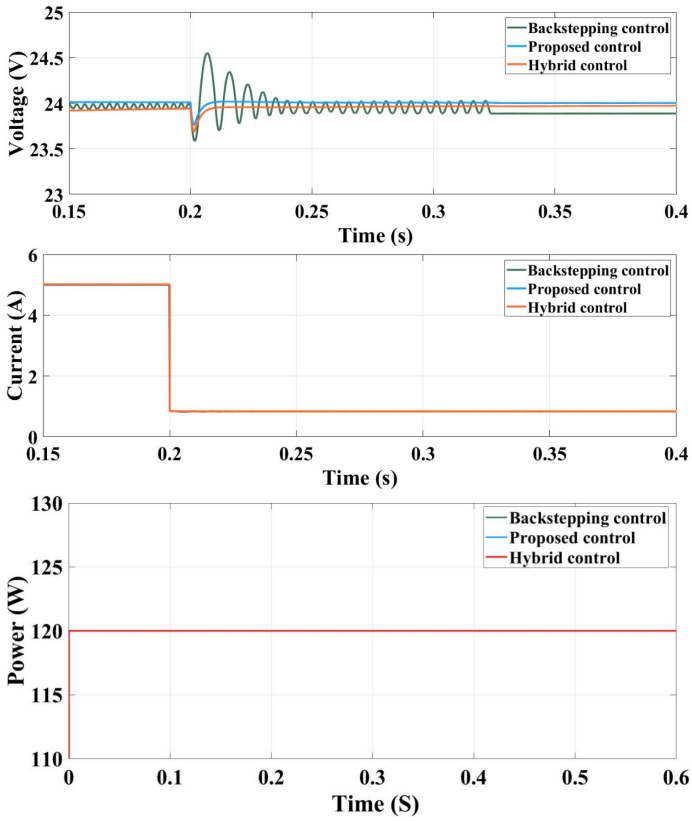

Fig. 7. Output Voltage and load current in scenario 2

V. CONCLUSION

This paper has proposed an intelligent Hybrid fractional order controller to adjust the output voltage of a DC-DC buck converter interfaced with CPL. An ANN-based regulation approach was proposed to provide real-time and adaptive adjustment of the parameters existing in the Hybrid controller. The main advantage of the proposed strategy was the ability to generate dynamic outputs for control objectives. This comprises producing the control actions concerning the uncertainties and external disturbances in contrast to the traditional controllers. Simulation results have validated the benefits of the proposed solution and showed its effectiveness over the backstepping controller and Hybrid fractional order controller with constant gains.

VI. ACKNOWLEDGEMENT

This work was supported by the Reliable Power Electronic-Based Power Systems (REPEPS) project at the AAU Energy Department, Aalborg University, as a part of the Villum Investigator Program funded by the Villum Foundation.

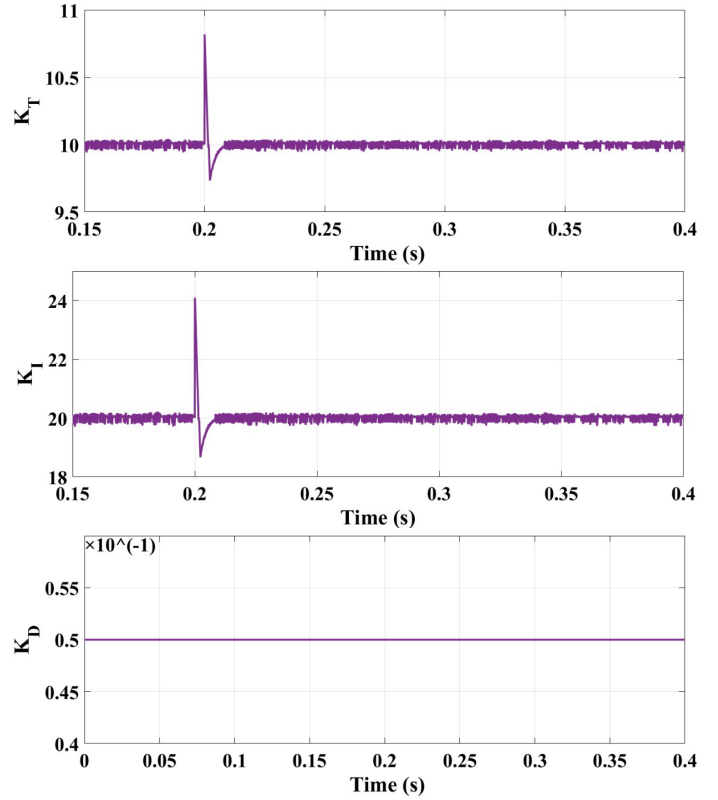

Fig. 8. Updated parameters of the Hybrid controller by ANN in scenario 2

REFERENCES

- [1] T. K. Nizami, C. Mahanta, "An intelligent adaptive control of DC-DC buck converters", *Journal of the Franklin Institute*, Volume 353, Issue 12, Pages 2588-2613, 2016.
- [2] M. Gheisarnejad, H. Farsizadeh and M. H. Khooban, "A Novel Nonlinear Deep Reinforcement Learning Controller for DC-DC Power Buck Converters," in *IEEE Transactions on Industrial Electronics*, vol. 68, no. 8, pp. 6849-6858, Aug. 2021.
- [3] J. Siegers, S. Arrua, and E. Santi, "Stabilizing controller design for multibus MVdc distribution systems using a passivity-based stability criterion and positive feedforward control," *IEEE J. Emerg. Sel. Topics Power Electron.*, vol. 5, no. 1, pp. 14-27, Mar. 2017.
- [4] M. Su, Z. Liu, Y. Sun, H. Han, and X. Hou, "Stability analysis and stabilization methods of DC microgrid with multiple parallel-connected DC-DC converters loaded by CPLs," *IEEE Trans. Smart Grid*, vol. 9, no. 1, pp. 132-142, Jan. 2018.
- [5] M. N. Hussain, R. Mishra, and V. Agarwal, "A frequency-dependent virtual impedance for voltage-regulating converters feeding constant power loads in a DC microgrid," *IEEE Trans. Ind. Appl.*, vol. 54, no. 6, pp. 5630-5639, Nov./Dec. 2018.

- [6] Q. Qi, D. Ghaderi, J. M. Guerrero, "Sliding mode controller-based switched-capacitor-based high DC gain and low voltage stress DC-DC boost converter for photovoltaic applications", *International Journal of Electrical Power & Energy Systems*, 106496, ISSN 0142-0615, Volume 125, 2021.
- [7] H. Sorouri; A. Oshnoei; M. Novak; F. Blaabjerg; A. Anvari-Moghaddam, "Learning-Based Model Predictive Control of DC-DC Buck Converters in DC Microgrids: A Multi-Agent Deep Reinforcement Learning Approach", *Energies* 15, no. 15: 5399, 2022.
- [8] H. Sorouri, M. Sedighizadeh, A. Oshnoei, R. Khezri, "An intelligent adaptive control of DC-DC power buck converters", *International Journal of Electrical Power & Energy Systems*, Volume 141, p.108099, 2022.
- [9] S. Oshnoei, A. Oshnoei, A. Mosallanejad, and F. Haghjoo, "Novel load frequency control scheme for an interconnected two-area power system including wind turbine generation and redox flow battery," *Int. J. Electr. Power Energy Syst.*, vol. 130, p. 107033, 2021.
- [10] S. Oshnoei, A. Oshnoei, A. Mosallanejad, F. Haghjoo, "Contribution of GCSC to regulate the frequency in multi-area power systems considering time delays: A new control outline based on fractional order controllers", *International Journal of Electrical Power & Energy Systems*, Volume 123, 2020.
- [11] S. Rao, *Engineering Optimization: Theory and Practice*, 4th ed. Hoboken, NJ, USA: Wiley, Jun. 2009.
- [12] A. Amirahmadi, M. Rafiei, K. Tehrani, G. Griva, and I. Batarseh, "Optimum design of integer and fractional order PID controllers for boost converter using SPEA look-up tables," *J. Power Electron.*, vol. 15, no. 1, pp. 160–176, Jan. 2015.
- [13] S. Singh and D. Fulwani, "Voltage regulation and stabilization of DC/DC buck converter under constant power loading," 2014 IEEE International Conference on Power Electronics, Drives and Energy Systems (PEDES), Mumbai, India, pp. 1-6, 2014.
- [14] R. Caponetto, G. Dongola, L. Fortuna, and I. Petráš, *Fractional Order Systems*. Singapore: World Scientific, 2010. [Online]. Available: <https://www.worldscientific.com/doi/abs/10.1142/779>
- [15] P. Warriar and P. Shah, "Fractional Order Control of Power Electronic Converters in Industrial Drives and Renewable Energy Systems: A Review," in *IEEE Access*, vol. 9, pp. 58982-59009, 2021, doi: 10.1109/ACCESS.2021.3073033.
- [16] M. Ö. Efe, "Fractional order systems in industrial automation—A survey", *IEEE Trans. Ind. Informat.*, vol. 7, no. 4, pp. 582–591, Nov. 2011.
- [17] R. Khezri, A. Oshnoei, A. Yazdani, A. Mahmoudi, "Intelligent coordinators for automatic voltage regulator and power system stabiliser in a multi-machine power system". *IET Gener Transm Distrib* ;14(23):pp. 5480–90, 2020.
- [18] H. Sorouri and M. Sedighizadeh, "Robust control of DC-DC converter supplying constant power load with Finite-Set Model Predictive Control," 2022 13th Power Electronics, Drive Systems, and Technologies Conference (PEDSTC), Tehran, Iran, Islamic Republic of, pp. 615-618, 2022.