

2000

A Comparison of Transfer Efficiency Using the Laser Touch on Manual Spray Guns in the Manufacturing Industry

Omar G. Blanco

Let us know how access to this document benefits you

Copyright ©2000 Omar G. Blanco

Follow this and additional works at: <https://scholarworks.uni.edu/grp>

A Comparison of Transfer Efficiency Using the Laser Touch on Manual Spray Guns in the Manufacturing Industry

A COMPARISON OF TRANSFER EFFICIENCY USING
THE LASER TOUCH™ ON MANUAL SPRAY GUNS
IN THE MANUFACTURING INDUSTRY

Industrial Technology
Research Paper

A Research Paper for Presentation
to the Graduate Faculty of
the Department of Industrial Technology
University of Northern Iowa

In Partial Fulfillment of the Requirements for
the Non-thesis Master of Arts Degree

by
Omar G. Blanco
May, 2000

Approved by:

Dr. Teresa Hall, Advisor

23 May 2000
Date

Dr. Vesta Burgess

25 May 2000
Date

ABSTRACT

This research was conducted to evaluate the performance of the Laser Touch™ targeting device once attached to a manual spray gun. It was perceived that this innovative tool increases the transfer efficiency of the spray process in painting and coating operations for the manufacturing industry. Also, it was theorized that the Laser Touch™ minimizes paint consumption and volatile organic compounds (VOC) in the spray system and improves the finish quality of the sprayed parts. Therefore, these parameters were compared and analyzed to determine the benefits of the Laser Touch™.

An experimental study was designed involving one group which was pre-tested, exposed to a treatment, and post-tested. All the independent variables were monitored and kept stable as possible during the study. The two critical factors were the Laser Touch™ targeting device and the spray technicians skill. The test was conducted in the Paint and Coating Enhancement (PACE) facility located in Cedar Falls, Iowa.

The study sample consisted of 12 spray technicians from the manufacturing industry. Two types of flat aluminum parts were sprayed by the spray technicians without and with the Laser Touch™ targeting device. A high volume-low pressure spray gun and a high solid coating were the basis of this study. Data was recorded, tabulated, and analyzed statistically using a spreadsheet program. Results of this study supported the research questions and confirmed that the Laser Touch™ is an effective tool for improving transfer efficiency, reducing paint consumption and volatile organic compounds released by the spray system.

ACKNOWLEDGMENTS

Thanks for this study are extended to the following people:

First of all, to my family for their encouragement. This study is dedicated to them.

Secondly, to the Iowa Waste Reduction Center staff for patiently working with me and guiding me throughout my program. Special thanks to John Konefes for his invaluable support. Within the university I would like to express my thanks to Dr. Teresa Hall, her professional advises and guidance contributed significantly toward the achievement of my goal.

TABLE OF CONTENTS

	PAGE
ACKNOWLEDGMENTS	ii
LIST OF TABLES	iv
LIST OF FIGURES	v
CHAPTER	
I INTRODUCTION	1
The Painting and Coating Spray process	2
The Transfer Efficiency of the Painting and Coating Process	3
The Laser Touch™ Targeting Device	4
The START Program	5
Statement of the Problem	6
Statement of the Purpose	6
Research Questions	6
Assumptions	7
Delimitations	7
Definition of Terms	7
II REVIEW OF THE LITERATURE	10
III METHODS AND PROCEDURES	16
Research Design	16
Experimental Facility	16
Population and Sample Selection	17

Test Parts Sizes and Characteristics	18
Test Parts Preparation	19
Test Panel Identification	19
Weighing the Test Parts	20
Spray Gun	20
Setup of Spray Gun	20
Overhead Conveyor	21
Coating Specifications	21
Transfer Efficiency	22
ASTM Standards	22
Video Cameras Setup	22
Testing Schedule	23
Testing Procedure	24
Pilot Test	25
Pre-Test	26
Preparation	27
Overhead Conveyor Line Set Up	27
Mixing the Paint	27
Preparing the Solids Aluminum Dishes	28
Solids Samples	28
Checking the Density, Temperature and Viscosity	30

Spraying the Pre-test Parts	32
Checking the Paint Mass Used	32
Quality Control	33
Curing the Pre-test Parts	33
Weighing the Pre-Test Parts	33
Film Thickness	34
Specular Gloss	35
Treatment	35
Instructing the Technicians	35
Post-Test	35
Curing the Post-Test Parts	36
Weighing the Post-Test Parts	36
Analysis and Calculations	36
Variables Used in Analysis	36
Numerical Analysis	36
Solid Contents	37
Calculation of Transfer Efficiency	37
Calculation of the Dry Film Thickness	37
Calculation of the Specular Gloss	37
Visual Appearance Evaluation	38
Interpretation of the Numerical Results	38
Evaluation of the Laser Touch	38

Data Analysis	39
IV PRESENTATION AND ANALYSIS OF DATA	41
Demographic Information	41
Report of the Study Findings	44
Descriptive Statistic	44
Inferential Statistic	44
Performance Evaluation	45
Independent Variables	56
Research Question One	61
Multiple Regression	65
Research Question Two	69
Research Question Three	71
Research Question Four	73
V SUMMARY, CONCLUSIONS, AND RECOMMENDATIONS	76
Summary	76
Conclusions	78
Conclusion Related to Research Question One	78
Conclusion Related to Research Question Two	79
Conclusion Related to Research Question Three	79
Conclusion Related to Research Question Four	80
Recommendations	80

REFERENCES	82
APPENDICES	84
APPENDIX "A": PACE FACILITY LAYOUT	85
APPENDIX "B": TESTING AND LABORATORY EQUIPMENT	87
APPENDIX "C": STANDARD TEST PARTS	90
APPENDIX "D": TEST SPRAY GUN SPECIFICATIONS	92
APPENDIX "E": COATING PRODUCT DATA SHEET	94
APPENDIX "F": ASTM STANDARDS	96
APPENDIX "G": MIL THICKNESS TEMPLATE	98
APPENDIX "H": SPECULAR GLOSS TEMPLATE	100
APPENDIX "I": SPRAY TECHNICIAN INSTRUCTION FOR THE LASER TOUCH™	102
APPENDIX "J": LASER TOUCH™ RESEARCH QUESTIONNAIRE	113
APPENDIX "K": SPRAY TECHNICIAN RECORDED PATTERNS	115
APPENDIX "L": DATA COLLECTION FORMS	138

LIST OF TABLES

TABLE	PAGE
1. Estimated Schedule	23
2. Visual Inspection Glossary.....	40
3. Spray Technicians Educational Level	42
4. Spray Technicians Level of Experience and Training	43
5. Performance evaluation	46
6. Controlled Independent Variables	57
7. Ambient Condition Variables	58
8. Booth Airflow Variable	59
9. Spray Gun Set-Up Variables	60
10. Spray Technicians Pre and Post Tests and Differences	62
11. t - Test: Paired Two Set of Data for means - Full Parts	63
12. t - Test: Paired Two Set of Data for means - Window Parts	64
13. Multicollinearity Test for The Multiple Regression Analysis Model	66
14. Multiple Regression Analysis - Transfer Efficiency Full Parts	68
15. Multiple Regression Analysis - Transfer Efficiency Window Parts	68
16. Gallons of Paint Used	70
17. Pounds of Volatile Organic Compound Released	72
18. Descriptive Statistic Mil of Thickness and Specular Gloss Readings	74

LIST OF FIGURES

FIGURE	PAGE
1. Test Parts	18
2. Aluminum Dishes	29
3. Aluminum Dish Weighting Procedure Using the 210 g Electronic Scale	30
4. Spray Gun Weighting Procedure Using the 22,000 gr. Top Load Electronic Balance	32
5. Test Parts Weighting Procedure Using the 22,000 g Bottom Load Electronic Balance	34

CHAPTER I

INTRODUCTION

Environmental regulations have become stricter for the manufacturing industry in the last decade. Since the passage of the 1990 Clean Air Act Amendments, businesses are required to reduce their volatile organic compounds (VOC's) and Hazardous Air Pollutant (HAP) emissions. Painting and coating operations are a common process for most manufacturers and a leading contributor of VOC and HAP emissions. The majority of products produced by the manufacturing industry require painting and/or coating for protection and because consumers require products to be aesthetically pleasing to the eye (U. S. Environmental Protection Agency [EPA], 1990). Because of extensive industrial painting and coating use, there is an enormous potential to reduce VOC's and HAP's emissions. One approach of reducing VOC and HAP emissions is to improve technician spray technique to increase transfer efficiency (TE).

According to the EPA Manual of Pollution Prevention in the Paints and Coatings Industry (1996), maximizing TE is the most predominant approach to minimize pollution in painting and coating activities. Small amounts of improved TE can result in a significant reduction of VOC's and HAP's emissions. Another reason for businesses to improve TE, besides the environmental impact of increased TE, is that paint costs have risen considerably in last few years. A sensible way to lower operating expenses is to reduce paint consumption by increasing TE.

Spray technique has a significant impact on TE, material consumption and finish quality. Spray technicians who are trained on spray technique are more efficient and are able to attain better TE (Snowden-Swan, 1992). However, not only training can accomplish this task. The development of efficiency enhancing and pollution prevention tools will assist spray technicians in

improving their spray technique and increase TE. The Laser Touch™ targeting device has the capability to help spray technicians achieve proper spray technique in a short period of time.

The Painting and Coating Spray Process

Several application methods are found to be used in the manufacturing industry to finish end products using liquid coatings. The methods of applications more commonly found in the manufacturing industry are described as dip coating, flow coating, electro decomposition, coil coating and spray coating. The spray process is the oldest and the most used application method by today's manufacturing industry. The spraying process releases coating material through a small orifice once the gun is triggered. This mechanism originates the paint break down in small particles. The particles are ejected toward the object being coated depending of the air pressure. These small particles interact together to form a final coating film (EPA, 1998).

The spray process is subdivided into five types of application a) conventional atomization, b) low pressure-high volume atomization (HVLP), c) airless atomization, d) air-assisted airless atomization, and e) electrostatic atomization (Hund, 1998). All of them are used in painting and coating operations by the manufacturing industry depending on their specific needs. Among them, one spray technique that has gained acceptance as an alternative to reduce VOC's and material consumption is HVLP atomization.

HVLP atomization reduces overspray because of its high volume low pressure mechanism. This type of gun operates with air pressure lower than 10 psi. In this way, it complies with most of the already established air quality regulations. This application produces a smooth spray that penetrates cavities of difficult shaped parts. HVLP spray guns are said to reach an average of 65% transfer efficiency of the system.

The Transfer Efficiency of the Painting and Coating Process

Simply stated, the transfer efficiency (TE) of a spray finishing process represents the amount of material that adheres to the target as compared to the amount of material that was sprayed through the spray gun towards the target. In other words, TE measures the ratio between the amount of paint on the surface part by the amount of paint supplied. Generally, this fraction is expressed as a percentage and can be determined by calculating the volume or the mass of solids. For instance, 65 percent TE means that 65 percent of the material that leaves the spray gun is deposited on the part. The remaining 35 percent is lost as overspray, both a regulatory problem and cost overrun for the manufacturer (Graco,1995). Optimal TE is a key factor in industrial spray applications to reduce VOCs and HAPs emissions.

TE is affected by many variables, such as the technician's technique, shape and size of the part, appropriate distance from the gun to the part, spray booth arrangement, and spray gun setup. However, Callahan (1995) indicates that TE is more dependent on the spray technician than on the other variables. Likewise, Graco Inc. (1995), a spray gun manufacturer notes, "Operator variability alone can account for a 20, 50, or even 100 percent difference in TE" (p. 5). Therefore, reducing technicians' variability and improving their spray application skills will provide a-substantial reduction in pollution emissions (Iowa Waste Reduction Center [IWRC], 1998). Improving these skills could be attained by implementing the Laser Touch™ targeting device on paint spray guns.

The Laser Touch™ Targeting Device

The Laser Touch™ is an efficiency improvement and pollution reduction tool developed by the IWRC for painting and coating training. It is a patented targeting device that, according to the Spray Technique Analysis and Research (STAR) Program (1998), improves a spray technician's painting technique by reducing overspray and material consumption. When attached to a spray gun, its laser projects an image to provide the spray technician with a visual indication of gun-to-target distance, gun angle, and targeting. In addition, it assists the spray technician to obtain a consistent 50 percent overlap with each stroke. Those are the key factors to achieve high transfer efficiency (TE) which could translate to higher productivity, consistent quality finish, better material utilization, and protection of the environment (IWRC, 1998). The Laser Touch™ targeting device can be attached to any spray gun currently on the market.

The Laser Touch™ targeting device is believed to be an efficiency enhancing and pollution prevention tool that would contribute to reduced air emissions, consequently, less waste. This targeting device is believed to be a useful tool that will alert the technicians to control their spray technique. The Laser Touch™ has been used by the IWRC as a tool to train spray technicians in painting and coating operations, through its STAR Program. Theoretically, the Laser Touch™ has shown dramatic improvements in maintaining a consistent spray distance and position, proper gun angle, excellent overlap, and uniform coating thickness as well as an acceptable finish appearance. Thus, this study generated experimental data to support the Laser Touch™ improvement from a practical standpoint.

The STAR Program

The IWRC developed the STAR program to technically assist small businesses and to comply with environmental regulations concerning with painting and coating operations. Since 1994, the program focuses on automotive painting technicians technique through hands-on training. For a normal day, technicians simulate spray operations using automobile components (hood and fender) during pre and post-tests sessions. Two automotive coatings are employed to spray the components, base and clear finish. Data is gathered before and after coatings application to determine transfer efficiency, mil thickness variation, material consumption and VOC emission. The technician is also video taped while spraying, allowing them to view and critique their spray technique during the classroom session. In the classroom the technician is introduced to new and/or different practices and equipment, such as the Laser Touch™ targeting device.

Results from the past six years have shown that after STAR training, spray technicians may reduce their material consumption by as much as 29% while maintaining or improving finish quality. Volatile organic compound (VOC) emissions usually drop as much as 30% and the average technician's transfer efficiency often improves by 25% (STAR program, 1998). By reducing hazardous waste generation rates and air emissions, STAR training also reduced air pollution and therefore minimizes environmental liability. Because of the successful results of the STAR program, a similar program is being developed for industrial paint and coating operations by the IWRC. In support of this study, IWRC maintains extensive state-of-the-art experimental testing facility. This laboratory facility, Painting and Coating Enhancement (PACE), is used for training and as a research center for painting and coating applications.

Statement of the Problem

Previous research has indicated that spray technician's technique has a significant impact on the system TE. Thus, the problem of this study was to investigate the effectiveness of the Laser Touch™ targeting device in increasing transfer efficiency in manual spray painting and coating operations for the manufacturing industry.

Statement of the Purpose

The purpose of this study was to verify the ability of the Laser Touch™ targeting device, attached to standard paint spray guns, to achieve reduction in paint consumption and volatile organic compound emissions, as well as to improve finishing quality in paint and coatings' operations. In addition, it was intended to authenticate the Laser Touch™ targeting device as a production tool for manufacturing industry.

Research Questions

The following research questions were addressed in this study:

1. Did the Laser Touch™ targeting device improve the painting technique of the spray technicians as measured by transfer efficiency?
2. Did the Laser Touch™ targeting device minimize paint consumption as measured by pre and post test paint usage?
3. Did the Laser Touch™ targeting device reduce VOC's emissions as measured by pounds of VOC's released into the air by pre and post tests?
4. Was the Laser Touch™ targeting device an effective production tool for improving finish quality in painting and coating operations for the manufacturing industry?

Assumptions

The following underlying assumptions were made with respect to this study:

1. All the measurements were correctly taken and accurate.
2. All the instruments and devices involved in this study were operational/operated according to manufacturing guidelines.
3. The spray technicians effort were genuine manufacturing guidelines.
4. Spray technicians involved in this study were able to effectively provide a proper gun adjustment and a normal spray pattern.
5. The conveyor estimated time allowed the spray technicians enough time to complete the application tasks.

Delimitation

The following delimitations were inherent in this study:

1. This study included technicians from the states of Iowa, specifically, from the Northeast area.
2. This study was addressed to small businesses, i.e., having less than 100 employees.
3. The test equipment, the paint spray gun, and material spray coatings in this study were confined to one manufacturer.

Definition of Terms

The following terms were defined to clarify their use in the context of the study:

Coating: “A liquid composition which is converted to a solid protective, decorative, or functional adherent film after application as a thin layer.” (EPA, 1998, p. 6-26)

Cure: “Using heat, radiation, or reaction with chemical additives to change the properties of a polymeric system into a final more stable, usable condition. For liquid coatings, it is the process by which the liquid is converted into a solid film.” (EPA, 1998, p. 6-26)

Electrostatic Spray: “Methods of spray application of coating where an electrostatic potential is created between the part to be coated and the paint particles.” (EPA, 1998, p. 6-27)

Film Thickness: “The thickness of a coating measured in mils.” [1 mil = 1/1000 inches]. (PPG, 1998, p. 9-5)

Hazardous Air Pollutant: “Hazardous air pollutants (HAP), also referred to as ‘air toxics’, pose a significant threat to human health and the environment.” (EPA, 1998, p. 6-28)

High-solids: “Solvent-based coatings that contain greater than 50 percent solids by volume or greater than 62 percent solid by weight.” (EPA, 1998, p. 6-28)

High-Volume Low Pressure Spray (HVLP): “Spray equipment used to apply coating by means of a gun which operates between 0.1 and 10.0 psi air pressure. The high volume of air is produce for a turbine.”(EPA, 1998, p. 4-5)

Overspray: “Any portion of a spray-applied coating which does not land on a part and which is deposited on the surrounding surface.” (EPA, 1998, p. 6-29)

Paint: “The liquid material to coat or cover the surface of the part.” (ASTM D 5286, 1995, p. 1).

Paint Density: “The mass of a unit volume of the liquid paint material at any given temperature.” (ASTM D1475, 1996, p. 143).

Paint Viscosity: “A measure of the fluidity of a material” (ASTM D 4212, 1993, p. 476).

Part Weight: The difference in the weight of the part before painting and the weight of the part after painting (ASTM D 5286, 1995).

Solids Content: “The solids content as percent of the total volume of a sample of paint used.” (ASTM D 5286, 1995, p. 2)

Specular Gloss: “The relative luminous reflectance factor of a specimen in the mirror direction.” (ASTM D 523, 1994, p. 32).

Spray Application: “A method of applying coating by atomizing and directing the atomized spray toward the part toward the part to be coated.” (EPA, 1998, 6-31)

Transfer Efficiency (volume): “The ratio of the volume of paint solids deposited to the volume of the paint solids sprayed, expressed as a percent.” (ASTM D 5286, 1995, p. 1)

Transfer Efficiency (weight): “The ratio of the weight of paint solids deposited to the weight of the paint solids, expressed as a percent.” (ASTM D 5286, 1995, p. 1).

VOC Emissions: “The mass of volatile organic compound (VOCs), expressed as kilograms of VOCs per liter of applied coating solids, emitted from a surface.” (EPA, 1998, p. 6-32)

Volatile Organic Compound (VOCs): “Any organic compound not specifically exempted by the U.S. EPA that participates in atmospheric photochemical reactions. VOCs may be emitted during the application and/or drying of coatings.” (EPA, 1998)

CHAPTER II

REVIEW OF THE LITERATURE

Extensive work has been carried out by the coating industry and the government to control and eradicate volatile organic compounds VOC and hazardous air pollutants (HAP) emissions pollution from industrial sources. One of the major contributors to VOC emissions in the manufacturing industry was the coating and painting operations. Over the past 10 years, many regulations were addressed to control these operations on behalf of the environment. The United States Environmental Protection Agency (EPA) established regulations and programs to prevent pollution in the coating and painting industry. The agency also developed research and integrated teams to help find out solutions and alternatives to pollution emissions from spraying process. Numerous articles, journals, and handbooks were available to assess pollution prevention in the coating and painting operations, having one common objective, to improve the transfer efficiency (TE) of the process.

On the other hand, the manufacturing industry had adapted to governmental regulations regarding pollution emissions. This industry had needed to develop new standards that further decrease the amount of waste generated. The painting and coating industry equipment had upgraded their products to be between emissions parameters established by the EPA. Industrial coatings manufacturers had also changed formulas to achieve EPA requirements with regard to VOC emissions. However, aside this trend, new equipment and products cannot attain lower pollution emission by themselves. Trappani and Bauer (1994) stated that “spray guns are designed to be adjusted by the technicians...”, while Clark (1997) affirmed that “the best spray gun in the

world is only as good as the painter operating it.” Manufacturers of equipment and products relied on the technicians technique and together they were able to achieve higher TE ratios, consequently reducing pollutants to the environment.

Despite that TE is a simple calculation between the quantity of paint reaching the target and the quantity of paint being applied, almost always, the results do not achieve higher ratios. It was in part because TE is influenced by many variables such as gun set up, booth environment, type of paint, and target shape. Most of the variables dependent on the spray technician. Thus, many authors (Clark, 1995; Cravens, 1999; Joseph, 1998; Snowden-Swan, 1992; Trapani & Bauer, 1994; Triplett, 1995) agreed that the spray technician is the focus of TE and they have a great potential to boost higher transfer rates. Accordingly, providing spray technicians with appropriate training and precise equipment to carry out the spray process in a fashionable manner results in higher TE ratios. In addition, a technician who is well trained and equipped represents financial advantages to the company as well as an enormous benefit to the environment.

In 1992, Snowden-Swan conducted a study to determine which factors most strongly affected VOC's emissions and TE on a real life wood spray operation. Spray equipment type, size and geometry of the target, solid content of the coating, and spray technicians skills were tested. Other variables affecting TE such as air velocity, temperature, humidity, atomizing air pressure, and fluid flow were kept stable. The test included two levels of spray technicians. The experienced, with a background of more than 10 years and having used all the types of guns tested and, the novice, with less than one year of experience in the field, basically having HVLP guns background. Two parts with unequal geometry, a cabinet door and a cabinet frame, were used. A

set of three doors and cabinet frames were provided to the spray technician to be coated. Three different types of coating were employed to spray the parts: a solvent-based, a solid varnish, and a water-based lacquer. All of these had 25 to 40 percent in solid content. In addition, this study included three types of guns: a conventional, a high volume-low pressure (HVLP), and an air-assisted airless.

This study used a combination of weight and volume methods to calculate TE. The volume of the coating material was measured using a fluid flow meter. The mass of solids deposited on the parts was determined by weighing the specimens before and after spraying. Percent solid was calculated by weighing the coating into an aluminum dish and heating it for about two hours. The density was calculated using a weight-per-gallon cup and viscosity was obtained using a Zahn #2 cup. As a result, this study determined that the most influential factor on TE depended on the painters' skill level. This factor was rated #1 in comparison with any other variable. In 90% of the combination, the skilled technician achieves higher TE than the novice spray technicians. From these results, it was concluded that training and experience found on spray technicians was fundamental to accomplish higher TE ratios.

The effects of increase gun-target distance was reported by Hicks, Senser, Kwok and Liu (1993). They investigated the relationship among coating viscosities, paint pattern distance, and air pressure, variables which are dependent of the spray technician. After a study of the fluid pattern which was divided in two regions and an experiment with different viscosities, air pressures, and painting distances, it was observed a marked difference as gun-target distance was increased. To determined the magnitude on TE variation, Hicks et al., (1993) kept viscosity and

air pressure constants to 57 cSt and 262 kPa (38 psi) respectively. Then, the gun was triggered from three different distances of the part, 17.8 centimeters (7 inches); 25.4 centimeters (10 inches); and 35.6 centimeters (14 inches). As a result of this study, it was concluded that the effect of gun-target variation from shortest to longest distance has a negative correlation on TE of 24 percent.

Ewert, Felstein, and Martinez (1993) carried out a study to evaluate transfer efficiency of several types of HVLP guns. In addition, their study was aimed to find out the ability of the HVLP guns to spray aerospace coatings according to desired quality requirements. The study included 14 spray systems in which not only HVLP guns were used but also a conventional and an airless air-assisted guns were employed as control gun. Each one of these spray guns sprayed each one of the common military coatings used in this evaluation. Six high solid coatings containing different viscosities and formulation (epoxies and polyurethanes) were selected. A 12 inches x 12 inches standard aluminum sheets were also selected as test parts. To reduce spray technician variability one spray technician was assigned for the overall painting of the parts.

The results of this study demonstrated that the HVLP guns were capable of achieving 65 percent TE using high solid coatings. In general, the results showed that the polyurethane coatings had a better visual appearance than the other type of coating sprayed by any of the spray guns tested. It was also found that the pressure pot has similar capabilities that siphon cup systems in two of the best HVLP guns. Thus, HVLP guns were found to have some difficulties trying to atomize paint particles in high solid coats which affected finish quality. This study did not demonstrate data collection and analysis.

In a study to evaluate the feasibility for using low-VOC coating to replace higher-VOC coatings in industrial maintenance operations, Taylor, Cornstubble, and Kosusko (1995) remarked that “operator variability can have a great impact on painting efficiency and, therefore, on emissions” (p. 7). In this study, Taylor et al. tested several coatings, having VOC content variations, versus a high VOC content coating. Three different skill levels of spray technicians were used: one greatly experienced, one with a few years of experience, and one novice. Each spray technician applied the six types of coatings to equal number of standard test panels. Data evaluation was performed based on the type of coating applied by each spray technician versus VOC emissions. In general, the results showed that the experienced spray technician reduces overspray and reach lower VOC emissions.

Likewise, in an article that appeared in the Industrial Paint & Powder magazine, Triplett (1995) affirmed that from all variables affecting TE, perhaps the most important in terms of reducing VOC emissions was the performance of the spray technician. The spray technicians had to know the system, especially those variables in favor of them, guns-set up played an important role into the system and from here gun-target distance and part shape evolved immediately. In addition, Joseph (1998) stated that the guns were able to achieve higher TE, maximize costs, and reduce pollutants however it only can be attained if the spray technician handles the gun effectively and correctly.

In summary, technique and gun-set up were the two most relevant aspects influencing TE in the paint and coating system. These two factors depend on the spray technician. Great attention needs to be paid to these two factors to improve TE. Once the spray technician has

received the training and has been taught how to set the gun up, it is still not an easy task to keep the right distance from the gun to the target. However, with the Laser Touch™ attached to the gun instantaneous visual feedback can be provided to the spray technician about their spray technique. Technicians were able to attain proper spray gun distance, gun angle, ending, and overlap with the Laser Touch™ device implemented.

CHAPTER III

METHODS AND PROCEDURES

This study was carried out to determine the feasibility of the Laser Touch™ targeting device as a production tool in the manufacturing industry. It also evaluated the Laser Touch™ improvement on transfer efficiency (TE) in painting production operations. As a result, the benefits of this targeting tool in reducing VOC emissions and minimizing costs were obtained. Data collection instruments as well as procedures that were used to accomplish the objectives of this study are discussed in this section.

Research Design

This study was carried out following an experimental design. Experimental research was defined by Gay (1992) as “collecting data in order to establish cause-effect relationship, involving group comparisons...” (p. 16). This study fell in the pre-experimental type of group designs. It involved one group which was pre-tested, exposed to treatment, and post-tested. Through this experimental method, the ability of the Laser Touch™ targeting device to improve the overall efficiency of the painting and coating process was determined. The research team was defined as staff from the IWRC who participated or were assigned tasks in order to accomplish the research project.

Experimental Facility

The research was conducted at the Pace and Coating Enhancement (PACE) facility located in Cedar Falls, Iowa. A layout of the PACE facility is shown in Appendix A. The PACE facility simulated an industrial facility regarding painting and coating operations and it was

equipped with a back-draft liquid coating spray booth, infra-red cure oven, an overhead conveyor and associated equipment. Appendix B lists the various testing devices and equipment used to accomplish this study.

Population and Sample Selection

The population for this study consisted of 12 industrial spray painting technicians. It should be noted that, while the sample represented industrial manufacturing companies, the sample was not generated randomly. Rather, the sample was generated from a list of client firms associated with the IWRC. The majority of the sample was taken from small manufacturing companies in Northeastern Iowa. In addition, there was a small number of technical school student's participating.

The study was conducted with both experienced spray technicians, having more than 18 years of industrial painting and coating application experience and novice spray technicians, having less than three years of industrial painting and coating application experience. Five experienced spray technicians were evaluated where three out of five had some painting and coating training application. Seven novice spray technician were evaluated, including two technicians from a community college painting and coating program. These two had some type of painting and coating training among the novice spray technicians. Few of them were aware of the factors that influence TE and did not check these parameters at the time of spray at their regular job. In addition, nine technicians had experienced with an HVLP gun; however, eight technicians were inexperienced spraying with a high solids coating material.

Test Parts Sizes and Characteristics

Test parts for this study were acquired from a local steel metal work shop. A total of 492 panels were used in two different types. The test parts had an aluminum substrate and a rigid flat surface. This substrate was chosen due to its versatile use in the manufacturing industry and because it is a standard material in the field. The standard test parts are shown in Appendix C.

The test parts were 1.22 (4 ft) x 1.02 m (3 ft 4 in) with a thickness of 0.158 cm (0.0625 in). Two types of shapes were chosen for this project; a full solid shape part and a window frame shape part with four sections cut out. They had two 1.27 cm (½ in) holes punched in opposite corners to suspend them from the two conveyor hooks. Figure 1 shows the test parts characteristics as they were positioned in the spray booth ready to be sprayed by the technician.

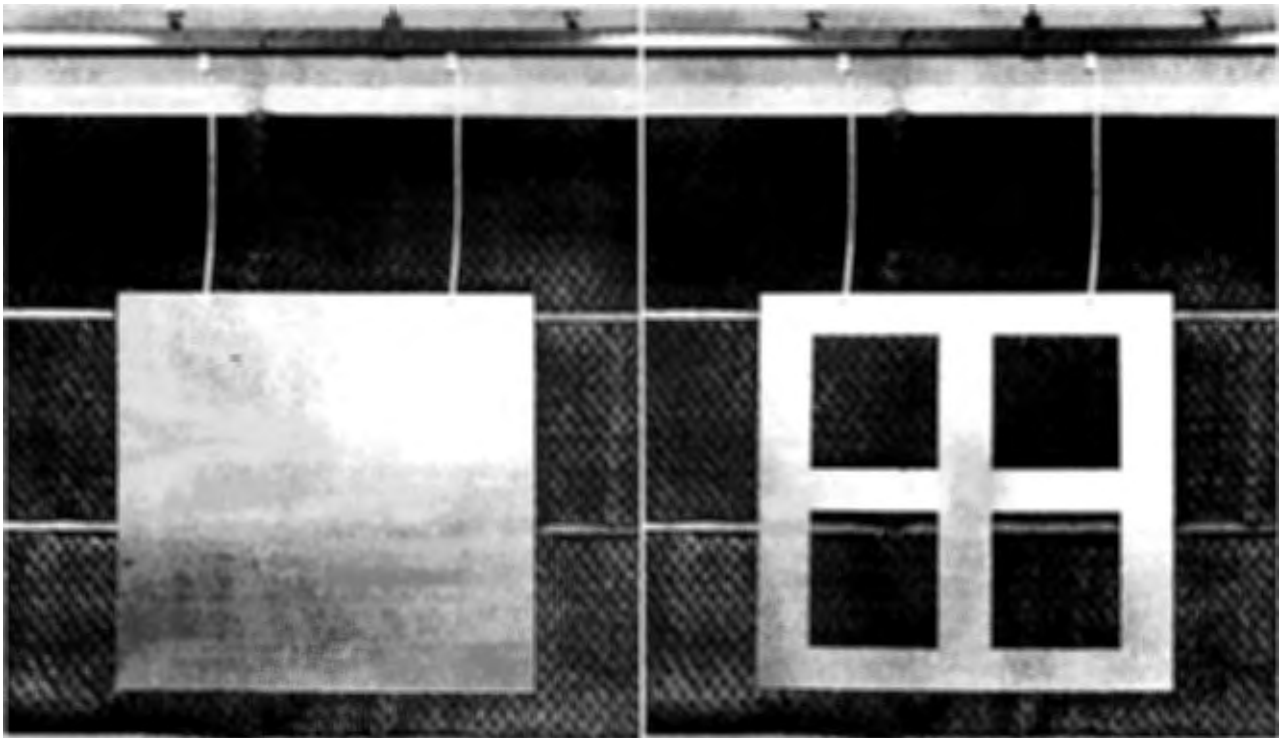

Figure 1. Test Parts for Study

Test parts preparation. As a preparation for coating, test panels received pretreatment from a local manufacturing company. The standard test parts were checked through visual appearance for the research team before being coated. Using a conventional solvent product and a paper towel the panels were cleaned if the presence of any contaminant particles were observed. After the panels were cleaned, they were only handled with latex gloves to prevent skin oils from being deposited on the surface.

Test parts identification. Each test parts were assigned an identification (ID) number for data analysis and control. Each ID number was stamped on the lower right-hand corner of the opposite side of spraying. An engraver machine was utilized for this task. The ID number used the following configuration:

1. The first letter corresponded to the shape of the test part. “F” for full parts and “W” for windows parts.
2. The second letter represented the spray technician. Each technician was assigned a letter for easy identification. For this study, letters were assigned from “B” to “M” which accounted for 12 painters.
3. The third letter identified the batch of a specific test. The “a” letter was assigned to the pre-test batch and the “b” letter was assigned to the post-test batch.
4. The fourth letter designated if the test parts were sprayed without the Laser Touch™ or with the Laser Touch™. The letter “N” was assigned when spraying was done without the Laser Touch™ and the letter “Y” was assigned when spraying was done with the Laser Touch™.

5. An ID number identified each single panel painted for the technician. Each technician was assigned seven parts; however, two digits were available in case any painter needed additional parts. An example of the part ID configuration as follows: WKaNO2.

Weighing the test parts. The test parts were clean and dry when weighed. The weight of each of the test parts was recorded before testing begun. The test parts were suspended while being weighed, and all sources of air movement such as fans, heaters, and large equipment were turned off avoiding any false reading over the electronic top load balance. The weight was recorded in the test log book, along with the identification number and letter of the part.

Spray Gun

A variety of spray paint guns are available in the marketplace today depending on desired capabilities. Five types of atomization are distinguished in spray paint guns: conventional, HVLP, air-assisted, air-assisted airless, and electrostatic. For this study an HVLP atomization gun was selected. This type of gun was chosen due to its versatile use in the manufacturing industry. A syphon cup gun was utilized to allow mobility and an easy weight procedure. Appendix D shows the specifications of the selected test spray gun.

Setup of spray gun. The spray gun was set up by each spray technician before testing. Technicians sprayed over a paper sheet until they reached an acceptable spray pattern. The painters were not allowed to make any adjustments to the spray gun once they started the test. Technicians were allowed to paint with the spray gun, on practice panels, as long as was necessary for them to become comfortable with the spray gun setup.

Overhead Conveyor

A conveyor was used to transport the test parts through the system. The time required to move the parts between the spray booth and the cure oven was determined and set constantly during the tests. The overhead conveyor was characterized by having a heavy duty track and chain with 280 ft long, provided by Rapid Industries, Inc. The overhead conveyor was automated with variable speed and reversible drive. Parts hooks were then added to the conveyor for an easy part take up and a comfortable spray application. Figure 1 shows part of the overhead conveyor and the hooks sustaining the parts inside the spray booth.

Coating Specifications

The standard test coating chosen to carry out the Laser Touch™ evaluation was a solvent-base Sherwin-Williams Polane® High Solids Plus Polyurethane Enamel, white color. This specific coating has two components and is VOC-compliant with less than 2.8 lbs/gal (336 g/l). The paint product data sheet for the standard test coating is showed in Appendix “E” (Coating Product Data Sheets). This type of coating was essentially chosen because it was reported to be one of the most common application coating employed in the manufacturing industry.

Despite the fact that this coating had shortened pot-life (3 hr) the research team managed the spraying application to be less than the stipulated time per run. Mixing ratios and cure time were followed according to manufacturer recommendations. Viscosity was also maintained between the manufacturer range from 50 to 65 seconds using a Ford cup # 4. Solid content for this particular color was kept close to the specified manufacturer range (76.2 %).

Transfer Efficiency

Transfer efficiencies percent were calculated to compare and evaluate the improvement of the Laser Touch™ targeting device. The TE calculations followed procedure A of ASTM D 5286 - 95. Since TE was dependent on many variables, a controlled experiment was set to keep the variables stable. For this study, TE determinations were calculated in each single panel sprayed by the spray technicians. An average of the seven pre-sprayed full parts was then obtained and compared with the average of the seven post-sprayed full parts. Similar analysis was performed with the window parts. Data was analyzed statistically using the data analysis tools, provided by Microsoft Excel 2000 to verify the performance of the Laser Touch™ targeting device. The resulting information was computed using a Corel Quattro® Pro 2000 spreadsheet program and outcomes from these operations were tabulated.

ASTM Standards

A series of standards tests developed and verified by the American Society for Testing and Materials (ASTM) was followed to accomplish this study. ASTM standards provided procedures and measurements to control materials and apparatus commonly used by painting and coating manufacturers. The ASTM tests were conducted by the research team in the PACE facility. The ASTM standards were included and described in the Appendix F.

Video Camera Setup

The Laser Touch™ test procedures were videotaped for future reference. Also, technicians spray applications were recorded and documented during pre-test and post-test. The intention of this videotaping was to review and analyze the procedures in case a particular test or

piece of equipment was suspected to be malfunctioning. The video was then used to calculate the time technicians spent spraying the coating on each test part.

Testing Schedule

Table 1 shows the planned schedule for the evaluation of the Laser Touch™ device. The Laser Touch™ research testing was followed as it was originally planned.

Table 1

Planned Schedule

<u>Spray Technician</u>	<u>Test Date</u>
Painter # B	October 19, 1999
Painter # C	October 22, 1999
Painter # D	October 26, 1999
Painter # E	October 28, 1999
Painter # F	November 2, 1999
Painter # G	November 4, 1999
Painter # H	November 9, 1999
Painter # I	November 11, 1999
Painter # J	November 16, 1999
Painter # K	November 18, 1999
Painter # L	December 8, 1999
Painter # M	December 10, 1999
Total= 12	

Testing Procedure

To evaluate the performance of the Laser Touch™ targeting device, this study was divided into pre-test, treatment, and post-test evaluations. The tests were performed by having technicians spray flat aluminum parts. Each technician sprayed a set of 14 panels for the pre-test, without the Laser Touch™ unit, and an identical number of panels for the post-test, with the Laser Touch™ unit. Each technician was exposed to treatment between pre-test and post-test. The treatment consisted of a one hour demonstration on how to use the Laser Touch™ targeting device with a manual spray paint gun.

The panels were divided and presented to the spray technicians in two runs. Each run consisted of two groups of seven panels having different shapes, Full and Window. Thirty minutes set up time was allowed to the spray technicians for practice, before the pre-test and the post-test, to be familiar with the system. Break time was also given to the spray technicians between the spray applications if it was required. The conveyor line was automatically set up to stop in the spray booth for six minutes. This was the specified time determined by the research team necessary for spraying the test part and weighing and refilling the spray gun.

The amount of material used to coat each panel was measured following the ASTM D 5286 - 95. The Laser Touch™ targeting device's effectiveness was evaluated upon increased transfer efficiency ratios. The independent variables such as temperature, humidity, booth air flow, paint viscosity, paint solid content, and paint density were kept stable as possible. However, in this research the spray technician's ability variable was not able to be controlled. Each spray technician set the air and fluid flows on the spray gun according to their criteria, and expertise in the painting

and coating field. The gun-to-part distance in the pre-test varied from technician to technician and was difficult to measure. Thus, during the post-test the gun-to-part distance was maintained constant to a six inches once the Laser Touch™ was attached to the gun.

Pilot Test

Prior to the evaluation of the Laser Touch™ targeting device, a pilot test was conducted to evaluate the appropriate coating, the most convenient spray gun, and the test parts' dimensions. Also, it allowed the research team to become familiar with the final research procedure. In addition, the pilot test was carried out to determine the best testing condition of the apparatus involved in the Laser Touch™ study.

This pilot test was divided into three phases: coating selection, spray gun selection, and standard test part area determination. The first phase included all the items related to the coat selection and mixing. It involved paint selection, viscosity, density, and percent volume solids. As a result, the standard test coating approved by the research team was Sherwin-William Polane HS Plus Polyurethane Enamel.

The second phase outlined choosing the adequate spray gun. To accomplish this phase several panels were sprayed with a stable gun-set up environment, i.e., keeping air pressure and fluid flow constants, and varying the distance from the gun to the target at ranges of 4, 5, 6, 7, and 8 inches. The effects of the HVLP atomization system was observed.

For the third phase, the results of phases one and two were applied to several panels with different areas and shapes. It allowed the researchers to know the best area-shape panel

compatible with the paint and spray gun selected. Finally, the spray gun selected for this study was the industrial Accuspray 19 series.

The third phase was based on the test part selection. Three standard test parts were sprayed in this preliminary test: a full part, a window part, and a diagonal part. The research team considered spraying five parts of each shape for the pre-test and the post-test. The dimensions of these test parts were 1.22 m (4 ft) x 1.22 m (4 ft). The window and diagonal parts were internally cut off to assess painters' ability. However, after testing the spraying process the research team realized that the technicians were fatigued due to the number of parts coated. This was due to fatigue caused by the weight of the siphon cup. It was filled at 3/4 cup, representing a heavy weight for the spray technician. As a result, the research team decided to test only two different shapes, full and window, instead of the three previously selected shapes. Also, it was decided to increase the number of parts from five to seven per group. In addition, the overall dimensions of the test parts were reduced to 1.22 m (4 ft) x 1.02 m (3' 4" ft).

During this preliminary test, three spray technicians were evaluated. Tests procedures as well as the test parts, coating, laboratory and ambient conditions, and ASTM standards were verified and reviewed. The results of this preliminary test defined the parameters involved and used in this study.

Pre-Test

The purpose of the pre-test was to evaluate the TE that a single technician achieved before the treatment. It also was used as the baseline for the Laser Touch™ evaluation. A set of 14 test parts were coated by each spray technician in the pre-test. They were hung and presented to the

spray technician in two continuous groups, each group having a different shape. Seven full shape test parts were sprayed for group number one and seven window shape test parts were sprayed for group number two. All the test parts received a pretreatment from an outside contractor and were sent to the PACE facility for storage.

Preparation. Before the testing day, twenty eight-test parts were selected for the spraying process. Two test parts of different shapes were selected as a control part and positioned before and after the 28 test parts. The control parts were used to determine if the test parts gained or lost weight during the spraying and drying process. The parts were also visually inspected by the research team and labeled according to the configuration described in the test part identification section. Any observance of dust or finger print was cleaned using a paper towel and a water-based cleaner. The test part temperature was measured and maintained approximately at 25°C (77 °F). Also, the booth temperature was maintained approximately at 25°C (77 °F). The readings, date, and time of day were recorded in a formatted table before testing for later analysis.

Overhead conveyor line set up. The speed of the overhead conveyor line was kept constant to 0.02 m/s (4.1 ft/min) with a dwell time of 6 min and a travel time of 60 s. Test parts to be sprayed were hung from hooks spaced 1.82 m (6 ft) on the center along the overhead conveyor line. The test panels were hung by ID on the conveyor and the technician sprayed them as they passed, simulating normal production operation.

Mixing the paint. The paint was mixed according to the manufacturers' directions. Coating requirements for film thickness, spray application, and curing were made following manufacturer recommendations. The temperature, viscosity and density of the mixed paint were also measured

following manufacturer recommendations and recorded before testing begun. Two batches of paint, a sufficient amount for the pre-test and post-test was mixed. A sample of 150 ml of paint from each batch was taken to determine solid content, viscosity, and density.

Preparing the solids aluminum dishes. The solids aluminum dishes were labeled with an identification number and letter. The labeling scheme for the pans matched the following model:

XxNN

X = letter

N = number

Example = Aa01

The first and second letter was a batch number and was specific to a single batch of paint. The numbers designated the individual aluminum dish. A minimum of five separate solid aluminum dishes were used for each batch. The dishes were pre-heated to a temperature of 110 ± 5 °C (230 °F) for 30 minutes and allowed to cool as specified by the ASTM standard for determining volatile content of coatings (ASTM D 2396 - 98). The preheated dishes assured that the weight of the dishes were not changed when the coating was cured at elevated temperature. The weight of the dishes were entered into the coating solid log form along with the identification number.

Figure 2 shows the aluminum dishes used to calculate the solid content of the paint.

Solids samples. Samples of the paint for solids testing were taken after the paint was mixed. A syringe was filled with paint and weighed. A small volume of paint (approx. 0.5 ml) were then placed into the five pre-weighed aluminum dishes.



Figure 2. Aluminum Dishes Ready to Place in the Oven

The syringe was re-weighed to determine the mass of paint in the aluminum dishes. A few drops of a reducer (3 +/- 1 ml) was added to thin the paint, so that it would spread out into a thin film and dry completely in the cure oven. The aluminum dishes were allowed to stand for 1 hour at room temperature. They were then placed in the oven and heated to 110 °C (230 °F) for 60 minutes. After heating, the pan was placed in a desiccator and allowed to cool. Once cool, the pan was weighed and the weight was recorded in the coating solids log. Figure 3 shows the aluminum dish weight procedure using the 210 Kg. electronic scale. The percent of solids were calculated as: $N = [(W2 - W1) / S] \times 100$

where:

W1 = the weight of the dish

W2 = weight of dish plus specimen after heating

S = Specimen weight (Sy1 - Sy2)

Sy1 = Syringe before dispensing paint

Sy2 = Syringe after dispensing paint



Figure 3. Aluminum Dish Weighing Procedure Using the 210 g Electronic Scale

Checking the density, temperature and viscosity. The density of the paint was calculated using the standard test method D 1475 - 96. A pycnometer was employed to determine paint density. The paint volume was calculated using the following formula:

$$V = (N - M) / p$$

Where:

V = volume of pycnometer, ml

N = weight of pycnometer and water, g

M = weight of dry pycnometer, g

p = absolute density of water at specific temperature, g/ml

After obtaining the mean of at least three determinations, the density of the paint was calculated as follows:

$$D_m = (W - w) / V$$

Where,

D_m = density, Lb/gal

W = weight of the pycnometer with the sample, g

w = weight of the pycnometer dry, g

V = Volume of pycnometer

The viscosity of the paint was calculated using ASTM 1200 - 94. A Ford cup # 4 was used to determine the fluidity of the material. A sample of the paint (150 ml) was taken and kept in storage following ASTM D 3925 - 91. As soon as the paint was mixed, following the manufacturer recommendations, the sample was placed in a dry, clean glass container to avoid evaporation. The Ford cup # 4 was filled with the prepared specimen and the efflux time recorded until the first break on the stream. A digital timer was used to measure efflux time. Viscosity determination was carried out in the mixing room where the temperature of the paint was kept stable and was measured with the thermocouple module of a digital multimeter. The temperature inside the mixing room was maintained at 25°C (77°F). Paint temperature, efflux time, and density were recorded on the density measurement form. The time of flow in seconds was converted to kinematic viscosity (v).

Spraying the pre-test parts. The first group of seven test parts were sprayed without the use of the Laser Touch™ targeting device. This established a control group of parts. Technicians were provided with test parts to practice in a period of 30 minutes before testing begun. Once the spray technician was comfortable with the spray gun, the first group of parts were presented to be sprayed simulating normal operation conditions using the overhead conveyor system.

Checking the paint mass used. The mass of fluid used to paint each individual panel was weighed using the bottom load scale. The gun cup was disconnected from its hoses and transported to the bottom load scale which was located outside the spray booth. Once the weight was obtained, it was recorded in the gun weight after form. Then, the gun cup was filled to 3/4 capacity, weighed again, and recorded on the gun mass table in the test data forms. The spray gun was returned to the spray booth for use by the technician. Figure 4 shows the spray gun weighing procedure using the 22,000 grams top load electronic scale. It also shows the weighing procedure without and with the Laser Touch™ targeting device.

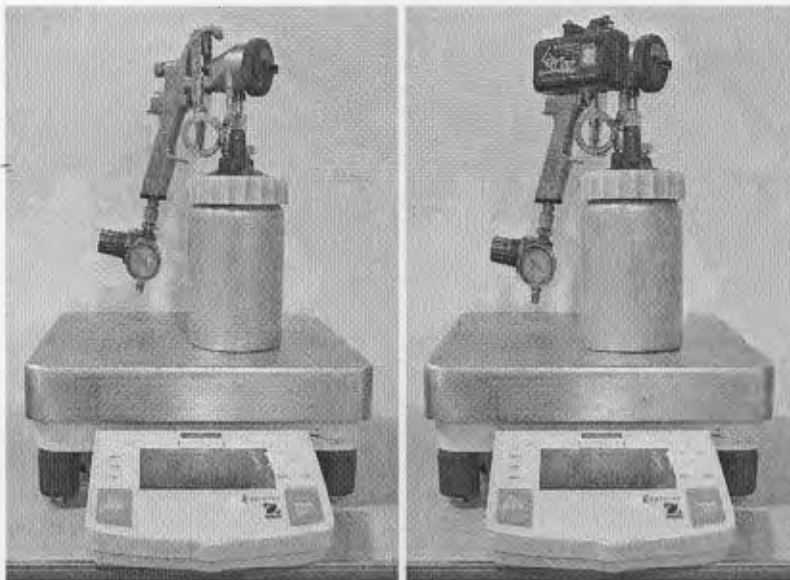

Figure 4. Spray Gun Weighing Procedure Using the 22,000 g Top Load Electronic Balance

Quality control. The presence of finishing defects in the sprayed coat could trap solvent and distort the transfer efficiency values. Therefore, a visual inspection was performed on the panels to determine an immediate pass or fail of the parts based on the following criteria: a) a visually noticeable run or sag, b) a visually noticeable drip, or c) a visually noticeable lightly coated area. The test part that did not pass the quality criteria was removed from the population test data. This selection of the coating panels using visual inspection followed ASTM 3964 - 80.

Curing the pre-test parts. The test parts were fully cured before being weighed. This was accomplished by running them through an infrared/convention cure oven until they reached the specified temperature. Curing of the test parts was completed as a two step process. Within one hour after the coating was applied, each test part was dried at 82°C (180°F) for seventeen minutes. After the pre-test and the post-test were performed, test parts were cured overnight using the infrared/convention oven for an additional 77 minutes at 82°C (180°F). The setup of the cure oven was recorded on the conveyor set up form to assure that the cure oven was operated consistently. The temperature of each part as it was in the cure oven was measured with an infrared thermometer and recorded on the conveyor set up form.

Weighing the pre-test parts. After the test parts were fully dried, they were re-weighed. The test parts were hung from the bottom load electronic scale and weighed as before, with all sources of air movement turned off. The results were recorded on the pre-test data form and entered into the spreadsheet for pre TE calculation. Figure 5 shows the test parts after spray and the weighing procedure using the bottom load electronic scale.

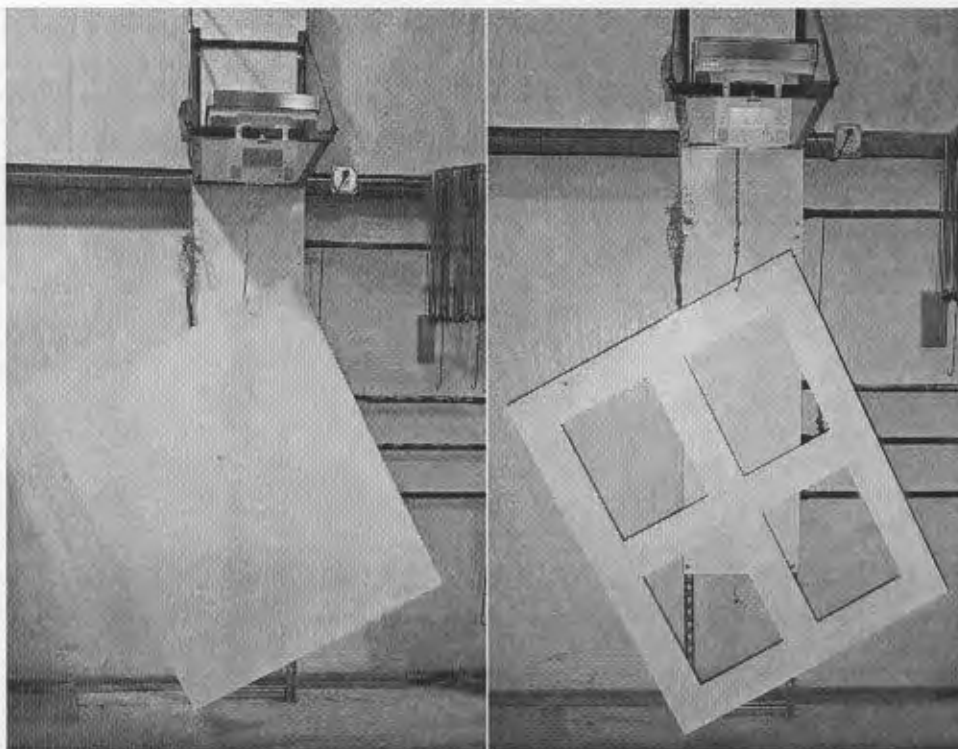

Figure 5. Test Parts Weighing Procedure Using the 22,000 g Bottom Load Electronic Balance

Film thickness. The film thickness (mil) of the paint on each test part was calculated using a nonferrous thickness coating gauge. This test followed ASTM D 1400. Several mil thickness points were determined for each test part-shape such as is shown in Appendix G. A template was made of solid material to consistently take the mill thickness measurements for each type of part. Technicians were directed to spray at manufacturer recommended film thickness between 1.25 and 1.5 mils in one coat. The mill thickness readings were also recorded in the pre-test data form for data control and later calculation.

Specular gloss: A standard test method for specular gloss was carried out to calculate the luminous reflectance of a test part as a measure of quality. This procedure followed ASTM D 523. Measurements were made with a 20° geometry. A properly calibrated glossmeter was employed to take these measurements. Twelve specular gloss readings were obtained from each sprayed test part. A solid format was utilized to take the specular gloss readings on the test parts. Appendix H shows the solid format and the location of the twelve points used for the gloss measurement.

Treatment

Instructing the technicians. After spraying the pre-test parts, the painters were introduced to the Laser Touch™ unit and instructed in the proper use of this device. A half-hour classroom session was provided to the spray technicians. Another half-hour was spent practicing with the Laser Touch™ unit to become accustomed to spraying with it. Appendix I describes the Laser Touch™ instructions used for training the spray technicians.

The Laser Touch device was then installed on the spray gun used to paint the previous sets of test parts. It was set up to a specific and pre-determined distance of 15 cm (6 in) and held at that constant distance during the post-test spray process. The spray technicians were given a demonstration using the Laser Touch™ unit to aim, check and maintain distance, and improve spray overlap.

Post Test

Once the painters were ready to begin painting, the density, temperature, and viscosity measurements of the paint were verified. In addition, the solid content of mixed paint was

calculated. All these procedures followed ASTM standards employed in the pre-test. The spray technicians were asked to paint in a similar pattern as they did for the pre-test panels.

Curing the post-test parts. The post-test panels were cured under the same conditions as the pre-test panels. The same procedures used in the pre-test were maintained for the post-test. Oven setup, line speed, and cure temperature parameters were kept consistent in the pre-test and post-tests.

Weighing the post-test parts. The post-test set of panels were weighed following the same procedures used for the pre-test set of panels. Mil thickness and specular gloss measurements were also made and recorded.

Analysis and Calculations

Variables Used In Analysis

PS: The mass of (wet) paint sprayed in grams measured weighing the spray gun before and after the spraying process.

SS: The mass of dry paint (solids) sprayed in grams is equal to $(PS \times \%S) / 100$.

SD: The mass of solids deposited in grams.

%S: The percent of the coating which is non-volatile (solids). It was determined using the solid content formula presented in the following solid content section.

TE: Transfer Efficiency is equal to $(SD) / (SS)$, often expressed as a percent.

Numerical Analysis

The Transfer efficiency of each test part was calculated as:

$$TE \text{ (percent)} = (SD) / (SS)$$

The accuracy of this value was calculated based on the accuracy of each of the measurements collected during the pre-test and post-test phases of the study.

Solids Content

The solid content was the difference between two masses: the wet mass and the dry mass of the paint. The procedure specified four measurements were to be made: 1) mass of the empty pan (EP); (2) mass of the full syringe (FS); (3) the mass of the empty syringe (ES); (4) and the mass of the pan with the deposited solids (PS).

$$\text{Thus, percent solid (\%S)} = (\text{PS} - \text{EP}) / (\text{FS} - \text{ES}) \times 100 \%$$

Calculation of Transfer Efficiency

The solid deposited (SD) value was the weight of the part after spraying and curing minus the weight of the bare part. The solid sprayed (SS) value was the product of wet paint sprayed (PS) measure multiplied by the percent solids (%S) calculation. The transfer efficiency was calculated using the formula $\text{TE (percent)} = (\text{SD} / \text{SS}) \times 100\%$.

Calculation of the Dry Film Thickness

The dry film thickness gauge was accurate within 0.1 mils. Since the mil build and variation measurements were intended for use as quality assurance measures only in this phase of testing, only reporting the expected accuracy was required. The expected mill thickness objective was within the manufacturer recommendation range.

Calculation of the Specular Gloss

Gloss was measured to assess finish quality. A glossmeter instrument was calibrated and employed to take the gloss measurements. The instrument provided information in gloss units and

had a range of 0 to 100 gloss units. For this test, it was expected that 80 gloss units was average for the pre-test parts. An improvement of 3% in gloss units for the post-test was determined to be acceptable.

Visual Appearance Evaluation

Each sprayed test part was evaluated through a visual inspection. No laboratory equipment was utilized for this evaluation. Test parts were evaluated for orange peel, stripping, coverage, pretreatment defects, and light coverage areas. The presence of any of these coating appearance defects was a cause in deciding to take out the part from the analysis. Table 2 shows the glossary employed to make a visual assessment on the test parts.

Interpretation of the Numerical Results

The overall accuracy of the test data allowed calculation of the TE to within \pm one percent. The largest uncertainty lied in the mass of paint used data, which contained a random error of about \pm 2% due to the solids calculation. The mass deposited data were estimated to be within \pm 1% and have an overall accuracy of \pm 3%. Under these conditions, a consistent increase of transfer efficiency of 2% or more was a mathematically valid improvement, and an increase of 5% would be clearly identifiable.

Evaluation of the Laser Touch™

The numerical calculations suggest that a 2% increase in overall transfer efficiency was an increase that could account for random error. Thus, a 2% increase could be deemed an 'improvement' and the Laser Touch's™ performance classified as 'good.' An increase of 5% or

more qualifies as a 'significant improvement,' and if the Laser Touch™ was able to reproduce this result, the performance of the device was classified as 'excellent'.

Data Analysis

The first step was to describe and summarize the data using a descriptive statistic. Means and standard deviations as a measure of central tendency and variability were calculated from the sampled variables. Differences between pre-tests and post-tests were then computed and averaged to indicate the improvement of the Laser Touch™ targeting device in every relevant category.

The second step follows an inferential statistic. It was used to infer the results of the sample to the true population. It also was used to determine the difference between the two samples means. A test of significant was applied to the data to allow the researcher to determine whether or not there was a significant difference between the pre-test and pot-test means. A t-test was used in this study to test the null hypothesis at 95% probability level.

The third step included a multiple regression analysis. A multiple regression analysis was performed to make a more accurate prediction. It determined the degree in which the independent variables were related to the dependent variable. It also calculated the value of a specific independent variable when the others were kept constant.

Table 2

Visual Inspection Glossary

Abbreviation	Signifying
V.G.O.C	Very Good Overall Coverage
G.O.C	Good Overall Coverage
S.	Runs and Drips
F.E.	Fisheyes
L.S.	Lite striping
H.S.	Heavy Striping
L.T.F.P.	Lite Top First Pass
L.T.P.	Lite Top Pass
L.R.E.	Lite Right Edge
L.C.O.	Lite Coverage Overall
S.L.A.	Scattered Lite Areas
L.A.	Lite Areas
P.T.	Pretreatment Troubles-Finger Prints
E.L.	Edges Lite
L.T.C.M.	Lite Top Cross Member
S.S.P.	Slight Solvent Popping
T.E.L.	Top Edge Lite

CHAPTER IV

PRESENTATION AND ANALYSIS OF DATA

This study was conducted to evaluate the performance of the Laser Touch™ targeting device once attached to an industrial paint spray gun. Also, this study sought to determine the transfer efficiency of the system using a controlled environment and varying spray technicians. In addition, this study researched the reduction of paint consumption and volatile organic compound (VOC) emissions as well as the improvement in the quality of the spray application implementing the Laser Touch™ targeting device on high volume-low pressure guns.

This chapter briefly describes the demographic information of spray technicians as they were tested and answers the study research questions. An analysis of the study findings is reported. The statistical test selected and applied to the data is described.

Demographic Information

Appendix J shows the questionnaire used to gather demographic information from the tested spray technicians. The following tables summarize the computed demographic information from the spray technicians population. A total of 12 technicians were tested on information pertinent to this group. The questionnaires reported that the spray technicians were working for different manufacturing companies with spray painting applications tasks. Table 3 represents the educational level among the spray technician group. Eight out of the twelve spray technicians had high school level education, three had additional technical school program degree in painting and coating operations, and one of the technicians had limited education.

Table 3

Spray Technician Educational Level

Education	# of Technicians
No Education	1
High-School	8
Technical School	<u>3</u>
Total	12

In addition to asking about the level of education, spray technicians were also asked to indicate their years of experience and any training in painting and coating operations they may have had. It was observed that many of the spray technicians (7) had less than three years of experience. The remaining of the spray technicians (5) had more than 18 years of painting experience. The entire group was then divided into novice spray technicians (less than three years of experience) and the experienced technicians (more than 18 years of experience). It is important to mention that most technicians who had any type of painting and coating training received the training early in their careers. Table 4 shows the degree of expertise among the spray technician group and if training was received during their painting and coating career.

Others key elements associated to the spray equipment and the type of coating employed by the technicians in their daily tasks were determined. It was observed that many of the technicians had experience using high a volume low pressure (HVLP) spray gun. However, many

of them had not sprayed a high solid coating previously. In addition, many of them were not aware of transfer efficiency (TE) as it applies to painting and coating operations.

Table 4

Spray Technicians Level of Experience and Training

Spray Technician	Experience		Training	
	Experimented	Novice	YES	NO
“B” ^a		X	X	
“C” ^a		X	X	
“D”		X		X
“E”		X		X
“F”		X		X
“G”		X		X
“H”	X			X
“I”	X		X	
“J”	X		X	
“K”		X		X
“L”	X			X
“M”	<u>X</u>	<u>—</u>	<u>X</u>	<u>—</u>
Total	5	7	5	7

Note. ^a Painting and Coating Community College Program.

Report of Study Findings

This section reports the analysis of the research findings and summarizes the data gathered in the evaluation of the Laser Touch™ device. The primary purpose of this research was to determine the effects on transfer efficiency implementing the Laser Touch™ in manual spray guns. Also, it was intended to investigate the reduction in paint consumption and volatile organic compounds (VOC's) as well as finish quality improvement that the Laser Touch™ targeting device was capable to achieve. Therefore, a descriptive statistical analysis was calculated for the variables of the study. A further statistical analysis was conducted to evaluate the significance of the results.

Descriptive Statistics

Descriptive statistical analysis of transfer efficiencies, gallons of paint consumed, and volatile organic compounds' emissions are presented here. Regarding quality finish, the descriptive statistic of the overall mil build and gloss tests are defined. In addition, a controlled environment was set up where the independent variables were kept stable. This section reports the descriptive statistics of the independent variables which were the focus of this study.

Inferential Statistics

For inferential statistical analysis, a t-test for data generated from a matched pair experiment was used to assess the means of the pre-test and post-test. This study assumed a 95% confidence interval for all statistical analysis. The parameter of interest was the difference between the pre-test and the post-test means. This difference was labeled μ_D which was obtained from $\mu_{pre} - \mu_{post} = \mu_D$. The null and research hypotheses were defined as follows:

$$H_0: \mu_D = 0 \quad ; \quad H_a: \mu_D > 0$$

Regression analysis was used to predict the values of the independent variables from the dependent variables. A model was defined considering the most important independent variables. The model was considered satisfactory after required conditions were checked. This model is described further in this section.

Performance Evaluation

A visual inspection was performed after the curing process and before data analysis. The objective was to evaluate the quality of the coating on the test parts after the spraying process. It also determined the decision of evaluating the test parts for further analysis. Parts with an evident defect were removed of the analysis. Thus, many rejected parts were tested for mil build and gloss analysis. The majority of the test parts presented good overall coverage. Runs and sags were the most predominant defects found on the test parts. Pretreatment problems such as pinholes and finger prints were also found in test parts after the visual inspection.

Table 5 shows the results from the appearance evaluation performed in each coated test part. It also includes the abbreviations of the typical dry coat defects found on the standard test parts. Abbreviations were described in Table 2 from Chapter III Methods and Procedures. In addition, Table 5 contains the mil build (dry mils) and the gloss (units) readings obtained from each test part. The mil build and the gloss readings were averaged from twelve data points that were taken using a standard template. Each test part point was read on the same location in the mil build test and in the specular gloss test. Mils build appears to be high in several parts. Thus, because of the high percent in content of solids that this specific color (white) presented the mil build readings were accounted as being in range.

Table 5

Performance Evaluation

Spray Technician	TE Test	Sprayed Test Part ID	Visual Inspection ^a	Mil Thickness ^{b,c}	Specular Gloss ^{d,e}	Perform Results ^f	
"B" ^g	Pre-Full	FBaN01	LS.	1.38	84.83	Approved	
		FBaN02	HS,S.	1.48	85.37	Rejected	
		FBaN03	LS.	1.27	83.53	Approved	
		FBaN04	LS.	1.38	85.99	Approved	
		FBaN05	LS,LTP,PT.	1.27	84.18	Approved	
		FBaN06	S.	1.59	85.21	Rejected	
		FBaN07	LS.	1.36	84.55	Approved	
	Pre-Window	WBaN01	S.	1.44	85.73	Rejected	
		WBaN02	GOC.	1.45	85.11	Approved	
		WBaN03	GOC,LTP,FE.	1.03	85.38	Approved	
		WBaN04	VGOC,EL.	1.41	86.22	Approved	
		WBaN05	S.	1.63	85.78	Rejected	
		WBaN06	S.	1.58	85.84	Rejected	
		WBaN07	LA,GOC.	0.91	85.07	Approved	
	Post-Full	FBbY01	S.	3.03	85.82	Rejected	
		FBbY02	S.	2.56	86.40	Rejected	
		FBbY03	VGOC.	1.77	86.08	Approved	
		FBbY04	LE,GOC.	1.33	84.78	Approved	
		FBbY05	S.	1.83	85.97	Rejected	
		FBbY06	S,HS.	1.49	NR ^h	Rejected	
		FBbY07	S.	1.66	NR	Rejected	
	Post-Window	WBbN01	S.	1.70	85.61	Rejected	
		WBbN02	LTCM,GOC	1.30	85.53	Approved	
		WBbN03	S.	1.91	85.80	Rejected	
		WBbN04	S.	1.75	84.78	Rejected	
		WBbN05	GOC.	1.73	84.85	Approved	
		WBbN06	S.	1.95	NR	Rejected	
		WBbN07	S.	1.88	NR	Rejected	
	"C"	Pre-Full	FCaN01	LS,LTFP.	1.41	85.03	Approved
			FCaN02	HS,LA.	1.52	85.14	Rejected
			FCaN03	S.	1.79	85.70	Rejected
			FCaN04	LS,LRE.	1.57	84.13	Approved
			FCaN05	LS.	1.30	85.74	Approved
			FCaN06	LS.	1.50	82.49	Approved
			FCaN07	LS,LTFP.	1.19	78.78	Approved

Table 5

Performance Evaluation (continued)

Spray Technician	TE Test	Sprayed Test Part ID	Visual Inspection ^a	Mill Thickness ^{b,c}	Specular Gloss ^{d,e}	Perform Results ^f
"D"	Pre-Window	WCaN01	VGOC.	1.32	84.14	Approved
		WCaN02	VGOC.	1.36	83.11	Approved
		WCaN03	HS,SLA.	1.19	85.11	Rejected
		WCaN04	VGOC.	1.37	86.41	Approved
		WCaN05	VGOC.	1.56	85.60	Approved
		WCaN06	VGOC.	1.52	85.31	Approved
		WCaN07	VGOC.	1.36	86.17	Approved
	Post-Full	FCbY01	VGOC.	1.88	84.10	Approved
		FCbY02	HS,S.	2.25	86.28	Rejected
		FCbY03	S.	2.21	87.10	Rejected
		FCbY04	VGOC.	1.76	86.33	Approved
		FCbY05	VGOC.	1.50	87.40	Approved
		FCbY06	VGOC.	1.73	87.15	Approved
		FCbY07	PT,GOC.	1.68	86.70	Approved
	Post-Window	WCbN01	VGOC.	1.31	86.19	Approved
		WCbN02	LCO,LA.	1.35	87.20	Rejected
		WCbN03	VGOC.	1.56	86.70	Approved
		WCbN04	PT,GOC.	1.58	79.74	Approved
		WCbN05	LRE,GOC.	1.46	85.24	Approved
		WCbN06	VGOC.	1.52	86.46	Approved
		WCbN07	PT,GOC.	1.46	86.47	Approved
	Pre-Full	FDaN01	EL,GOC	1.18	80.44	Approved
		FDaN02	EL,GOC.	1.35	83.63	Approved
		FDaN03	LA,GOC.	1.28	83.50	Approved
		FDaN04	LRE,GOC.	1.51	83.95	Approved
		FDaN05	VGOC.	1.63	84.61	Approved
		FDaN06	VGOC.	1.47	84.14	Approved
		FDaN07	VGOC.	1.76	83.85	Approved
	Pre-Window	WDaN01	VGOC.	1.83	85.25	Approved
		WDaN02	VGOC.	1.64	84.21	Approved
		WDaN03	S.	1.65	85.31	Rejected
		WDaN04	PT,GOC.	1.59	85.87	Approved
		WDaN05	VGOC.	1.58	84.82	Approved
		WDaN06	VGOC.	1.49	85.18	Approved
		WDaN07	LA,GOC.	1.57	85.16	Approved

Table 5

Performance Evaluation (continued)

Spray Technician	TE Test	Sprayed Test Part ID	Visual Inspection ^a	Mil Thickness ^{b,c}	Specular Gloss ^{d,e}	Perform Results ^f
"E"	Post-Full	FDbY01	VGOC.	1.89	84.51	Approved
		FDbY02	VGOC.	1.74	86.09	Approved
		FDbY03	PT,GOC.	1.86	86.50	Approved
		FDbY04	VGOC.	1.81	85.99	Approved
		FDbY05	VGOC.	1.70	86.18	Approved
		FDbY06	VGOC.	1.78	86.08	Approved
		FDbY07	PT,GOC.	1.54	85.83	Approved
	Post-Window	WDbN01	VGOC.	1.70	85.51	Approved
		WDbN02	VGOC.	1.87	86.15	Approved
		WDbN03	VGOC.	1.92	85.12	Approved
		WDbN04	VGOC.	1.95	84.87	Approved
		WDbN05	VGOC.	2.05	85.48	Approved
		WDbN06	PT,LA.	1.88	85.91	Rejected
		WDbN07	VGOC.	1.84	84.08	Approved
	Pre-Full	FEaN01	HS,S.	1.20	82.00	Rejected
		FEaN02	LS,EL.	0.98	82.53	Approved
		FEaN03	LS,LTP.	1.25	83.01	Approved
		FEaN04	LS,LRE.	1.15	80.15	Approved
		FEaN05	LS.	1.15	80.13	Approved
		FEaN06	LS,LTP.	1.15	82.13	Approved
		FEaN07	LS.	1.02	83.52	Approved
	Pre-Window	WEaN01	LCO,SLA.	1.18	77.12	Approved
		WEaN02	SLA,GOC.	1.19	79.25	Approved
		WEaN03	LA,S.	1.30	82.12	Rejected
		WEaN04	LA,SLA.	1.17	82.95	Approved
		WEaN05	S.	1.22	74.37	Rejected
		WEaN06	LA,SLA.	1.16	83.30	Approved
		WEaN07	LA,LSA.	1.18	82.89	Approved
	Post-Full	FEbY01	LTP,GOC.	1.31	82.83	Approved
		FEbY02	PT,GOC.	1.34	73.98	Approved
		FEbY03	VGOC.	1.50	64.48	Approved
		FEbY04	PT,EL,GOC.	1.21	79.75	Approved
		FEbY05	LTP,GOC.	1.13	80.07	Approved
		FEbY06	VGOC.	1.20	73.33	Approved
		FEbY07	PT,GOC.	1.33	81.58	Approved

Table 5

Performance Evaluation (continued)

Spray Technician	TE Test	Sprayed Test Part ID	Visual Inspection ^a	Mil Thickness ^{b,c}	Specular Gloss ^{d,e}	Perform Results ^f
"F"	Post-Window	WEbN01	PT,LCO.	1.06	74.08	Rejected
		WEbN02	LS,GOC.	1.39	78.35	Approved
		WEbN03	PT,SSP.	1.23	78.45	Rejected
		WEbN04	VGOC.	1.42	74.66	Approved
		WEbN05	LA,SLA.	1.09	79.11	Approved
		WEbN06	VGOC.	1.47	73.96	Approved
		WEbN07	LTP,GOC.	1.43	62.57	Approved
	Pre-Full	FFaN01	LA,PT.	1.20	80.44	Approved
		FFaN02	LE,PT.	1.38	83.63	Approved
		FFaN03	PT,GOC.	1.45	83.50	Approved
		FFaN04	LCO,GOC.	1.32	83.95	Approved
		FFaN05	PT,LCO.	1.43	84.61	Approved
		FFaN06	EL,LOC.	1.43	84.14	Rejected
		FFaN07	EL,GOC.	1.46	83.85	Approved
	Pre-Window	WFaN01	PT,LA,LCO.	NR	85.25	Rejected
		WFaN02	LA,GOC.	1.53	84.21	Approved
		WFaN03	GOC.	1.48	85.31	Approved
		WFaN04	EL,GOC.	1.50	85.57	Approved
		WFaN05	PT,LCO.	1.60	84.82	Rejected
		WFaN06	FE,LA.	1.22	85.18	Approved
		WFaN07	LOC.	1.27	85.16	Approved
	Post-Full	FFbY01	LS,EL.	1.06	84.51	Approved
		FFbY02	LS,PT.	1.06	86.09	Approved
		FFbY03	LT,PT.	1.27	86.50	Approved
		FFbY04	HS,S.	1.24	85.99	Rejected
		FFbY05	LS,PT.	0.98	86.18	Approved
		FFbY06	LA,LCO.	1.18	86.08	Approved
		FFbY07	LS,LTP.	0.86	85.83	Approved
	Post-Window	WFbN01	S.	1.41	85.51	Rejected
		WFbN02	LS,SSP.	1.56	86.15	Approved
		WFbN03	LTP.	1.79	85.12	Approved
		WFbN04	HS,S.	NR	84.87	Rejected
		WFbN05	LTCM,PT.	1.52	85.58	Approved
		WFbN06	SSP,PT.	1.59	85.91	Approved
		WFbN07	LA,GOC.	1.46	84.08	Approved

Table 5

Performance Evaluation (continued)

Spray Technician	TE Test	Sprayed Test Part ID	Visual Inspection ^a	Mil Thickness ^{b,c}	Specular Gloss ^{d,e}	Perform Results ^f
"G"	Pre-Full	FGaN01	LA,GOC.	1.23	75.29	Approved
		FGaN02	LS,GOC.	1.51	81.70	Approved
		FGaN03	VGOC.	1.90	83.93	Approved
		FGaN04	LA,EL,SSP.	1.88	85.32	Rejected
		FGaN05	LTCM,LCO.	1.70	82.07	Rejected
		FGaN06	VGOC.	1.69	83.52	Approved
		FGaN07	LRE,GOC.	1.33	66.93	Approved
	Pre-Window	WGaN01	LA,GOC.	1.59	79.93	Approved
		WGaN02	LE,S.	2.40	83.42	Rejected
		WGaN03	S.	2.36	81.78	Rejected
		WGaN04	LE,GOC.	1.48	77.52	Approved
		WGaN05	LE,LOC	1.02	62.66	Approved
		WGaN06	LOC.	0.77	39.34	Approved
		WGaN07	LA.	1.07	66.93	Approved
	Post-Full	FGbY01	VGOC.	1.55	85.10	Approved
		FGbY02	S.	1.32	84.28	Rejected
		FGbY03	LTP,SLA.	1.25	83.28	Rejected
		FGbY04	VGOC.	1.39	84.90	Approved
		FGbY05	VGOC.	1.34	83.87	Approved
		FGbY06	VGOC.	1.64	85.23	Approved
		FGbY07	VGOC.	1.44	85.24	Approved
	Post-Window	WGbN01	VGOC.	1.36	83.30	Approved
		WGbN02	VGOC.	1.52	83.88	Approved
		WGbN03	VGOC.	1.47	84.07	Approved
		WGbN04	VGOC.	1.38	84.06	Approved
		WGbN05	S.	1.61	84.45	Rejected
		WGbN06	VGOC.	1.78	84.66	Approved
		WGbN07	VGOC.	2.09	84.01	Approved
"H"	Pre-Full	FHaN01	LS,GOC.	1.94	85.43	Approved
		FHaN02	LRE,GOC.	2.22	84.31	Approved
		FHaN03	EL,GOC.	2.12	83.68	Approved
		FHaN04	S.	NR	NR	Rejected
		FHaN05	PT,S.	NR	NR	Rejected
		FHaN06	LTP,GOC.	2.04	84.78	Approved
		FHaN07	VGOC.	1.89	83.06	Approved

Table 5

Performance Evaluation (continued)

Spray Technician	TE Test	Sprayed Test Part ID	Visual Inspection ^a	Mil Thickness ^{b,c}	Specular Gloss ^{d,e}	Perform Results ^f
"I"	Pre-Window	WHaN01	VGOC.	1.71	83.62	Approved
		WHaN02	LTCM,GOC.	1.63	80.76	Approved
		WHaN03	LS.	1.93	83.37	Approved
		WHaN04	S.	1.90	82.78	Rejected
		WHaN05	EL,GOC.	1.83	83.44	Approved
		WHaN06	LTCM,TEL.	1.86	84.34	Rejected
		WHaN07	VGOC.	1.86	84.16	Approved
	Post-Full	FHbY01	VGOC.	2.04	85.47	Approved
		FHbY02	VGOC.	2.33	85.20	Approved
		FHbY03	VGOC.	NR	84.38	Approved
		FHbY04	S.	2.16	84.36	Rejected
		FHbY05	VGOC.	2.01	84.83	Approved
		FHbY06	VGOC.	1.55	85.50	Approved
		FHbY07	VGOC.	1.57	84.78	Approved
	Post-Window	WHbN01	VGOC.	2.07	84.42	Approved
		WHbN02	VGOC.	1.86	85.29	Approved
		WHbN03	S.	NR	NR	Rejected
		WHbN04	VGOC.	2.19	83.95	Approved
		WHbN05	EL,GOC.	1.30	83.73	Approved
		WHbN06	SLA,LCO.	1.40	83.68	Rejected
		WHbN07	VGOC.	1.35	81.08	Approved
	Pre-Full	FIaN01	LS,LA.	1.72	71.01	Approved
		FIaN02	LS,LA.	1.71	82.50	Approved
		FIaN03	LS.	1.70	74.62	Approved
		FIaN04	LS,GOC.	2.12	80.00	Approved
		FIaN05	LS.	1.82	80.18	Approved
		FIaN06	S.	NR	73.18	Rejected
		FIaN07	S.	NR	79.69	Rejected
	Pre-Window	WIaN01	S.	1.45	76.99	Rejected
		WIaN02	LA.	1.26	76.18	Approved
		WIaN03	LCO.	1.65	82.26	Approved
		WIaN04	S.	1.54	82.18	Rejected
		WIaN05	LA,EL.	1.62	79.97	Approved
		WIaN06	SLA.	1.57	78.68	Approved
		WIaN07	LA,EL.	1.47	74.13	Approved

Table 5

Performance Evaluation (continued)

Spray Technician	TE Test	Sprayed Test Part ID	Visual Inspection ^a	Mil Thickness ^{b,c}	Specular Gloss ^{d,e}	Perform Results ^f
"J"	Post-Full	FIbY01	VGOC.	2.09	84.43	Approved
		FIbY02	VGOC.	2.04	84.48	Approved
		FIbY03	VGOC.	2.08	84.37	Approved
		FIbY04	VGOC.	2.18	84.70	Approved
		FIbY05	VGOC.	1.42	84.38	Approved
		FIbY06	S.	NR	83.05	Rejected
		FIbY07	S.	NR	84.14	Rejected
	Post-Window	WIbN01	LCO,S.	1.30	81.58	Rejected
		WIbN02	LA,GOC.	1.39	81.60	Approved
		WIbN03	VGOC.	1.55	80.50	Approved
		WIbN04	VGOC.	1.50	81.62	Approved
		WIbN05	S.	1.70	81.63	Rejected
		WIbN06	VGOC.	1.50	82.75	Approved
		WIbN07	VGOC.	1.55	82.56	Approved
	Pre-Full	FJaN01	LA,GOC.	1.30	84.60	Approved
		FJaN02	VGOC.	1.57	85.00	Approved
		FJaN03	VGOC.	1.74	85.37	Approved
		FJaN04	VGOC.	1.65	85.25	Approved
		FJaN05	PT,S.	1.79	85.72	Rejected
		FJaN06	VGOC.	1.80	84.97	Approved
		FJaN07	LA,GOC.	1.63	84.91	Rejected
	Pre-Window	WJaN01	SSP,GOC.	1.24	83.94	Approved
		WJaN02	SSP,GOC.	1.60	85.01	Approved
		WJaN03	VGOC.	1.53	83.94	Approved
		WJaN04	S.	1.59	83.27	Rejected
		WJaN05	VGOC.	1.59	84.24	Approved
		WJaN06	VGOC.	1.58	85.50	Approved
		WJaN07	TEL,GOC.	1.60	84.30	Approved
	Post-Full	FJbY01	LA,GOC.	1.58	84.23	Approved
		FJbY02	LS,GOC.	1.46	84.66	Approved
		FJbY03	LE,LS.	1.60	84.98	Approved
		FJbY04	LE,LS.	1.47	85.01	Approved
		FJbY05	LS,LA.	NR	NR	Approved
		FJbY06	LS,GOC.	1.74	84.90	Approved
		FJbY07	LS,GOC.	1.37	85.30	Approved

Table 5

Performance Evaluation (continued)

Spray Technician	TE Test	Sprayed Test Part ID	Visual Inspection ^a	Mil Thickness ^{b,c}	Specular Gloss ^{d,e}	Perform Results ^f
"K"	Post-Window	WJbN01	EL,LA.	2.11	82.58	Rejected
		WJbN02	LRE,GOC.	1.88	83.41	Approved
		WJbN03	VGOC.	1.82	80.49	Approved
		WJbN04	VGOC.	2.07	82.26	Approved
		WJbN05	VGOC.	1.42	84.57	Approved
		WJbN06	VGOC.	1.37	84.08	Approved
		WJbN07	VGOC.	1.30	84.43	Approved
	Pre-Full	FKaN01	LA,GOC.	1.59	76.67	Approved
		FKaN02	VGOC.	1.59	83.23	Approved
		FKaN03	VGOC.	1.65	84.03	Approved
		FKaN04	VGOC.	1.79	84.15	Approved
		FKaN05	VGOC.	1.58	86.62	Approved
		FKaN06	LA,GOC.	1.55	84.04	Approved
		FKaN07	VGOC.	1.71	82.15	Approved
	Pre-Window	WKaN01	SSP,SLA.	1.52	82.49	Rejected
		WKaN02	VGOC.	1.47	81.23	Approved
		WKaN03	VGOC.	1.87	83.51	Approved
		WKaN04	EL,GOC.	2.05	83.73	Approved
		WKaN05	VGOC.	1.77	82.35	Approved
		WKaN06	LSA,SSP.	1.55	81.67	Rejected
		WKaN07	VGOC.	1.61	81.52	Approved
	Post-Full	FKbY01	LS,GOC.	1.23	80.83	Approved
		FKbY02	EL,LS.	1.25	81.43	Approved
		FKbY03	LS,GOC.	1.36	82.40	Approved
		FKbY04	VGOC.	1.33	82.03	Approved
		FKbY05	VGOC.	1.57	84.23	Approved
		FKbY06	VGOC.	1.38	81.33	Approved
		FKbY07	LA,GOC.	1.55	84.25	Approved
	Post-Window	WKbN01	LA,GOC.	1.49	81.81	Approved
		WKbN02	LTCM,GOC.	1.45	83.54	Approved
		WKbN03	VGOC.	1.61	82.89	Approved
		WKbN04	S.	1.52	82.25	Rejected
		WKbN05	LCO,S.	1.60	84.23	Rejected
		WKbN06	SSP,GOC.	1.64	84.53	Approved
		WKbN07	VGOC.	1.69	83.84	Approved

Table 5

Performance Evaluation (continued)

Spray Technician	TE Test	Sprayed Test Part ID	Visual Inspection ^a	Mil Thickness ^{b,c}	Specular Gloss ^{d,e}	Perform Results ^f	
"L"	Pre-Full	FLaN01	LS,GOC.	1.85	84.18	Approved	
		FLaN02	LS,GOC.	1.83	84.70	Approved	
		FLaN03	LS,GOC.	2.05	84.08	Approved	
		FLaN04	LS,LA.	1.88	85.07	Approved	
		FLaN05	LS,LTP.	1.84	83.21	Approved	
		FLaN06	LS,LTP.	1.94	84.90	Approved	
		FLaN07	S.	2.25	82.85	Rejected	
	Pre-Window	WLaN01	TEL,GOC.	1.53	83.25	Approved	
		WLaN02	S.	1.78	83.21	Rejected	
		WLaN03	LTFP,GOC.	1.78	81.03	Approved	
		WLaN04	PT,TEL,GOC.	1.54	82.18	Approved	
		WLaN05	TEL,GOC.	1.78	82.64	Approved	
		WLaN06	TEL,LCO,S.	1.89	82.70	Rejected	
		WLaN07	LTFP,GOC.	1.93	82.48	Approved	
	Post-Full	FLbY01	LTFP,GOC.	1.40	81.73	Approved	
		FLbY02	LA,EL.	1.29	79.24	Approved	
		FLbY03	SLA.	1.33	79.66	Approved	
		FLbY04	LTR,GOC.	1.62	83.83	Approved	
		FLbY05	TEL,GOC.	2.03	82.49	Approved	
		FLbY06	LRP,GOC.	1.75	81.08	Approved	
		FLbY07	VGOC.	2.25	83.86	Approved	
	Post-Window	WLbN01	VGOC.	2.16	80.90	Approved	
		WLbN02	LTCM,LA.	2.07	82.84	Rejected	
		WLbN03	S.	2.42	81.93	Rejected	
		WLbN04	VGOC.	2.12	81.86	Approved	
		WLbN05	LTP.	2.25	80.39	Approved	
		WLbN06	PT,LTP.	2.11	78.84	Approved	
		WLbN07	PT,GOC.	1.78	77.63	Approved	
	"M"	Pre-Full	FMaN01	LTP,GOC.	1.33	86.09	Approved
			FMaN02	LS,GOC.	1.41	86.01	Approved
			FMaN03	LTP,GOC.	1.52	86.16	Approved
FMaN04			LTP,GOC.	1.43	85.30	Approved	
FMaN05			LS,LTP,GOC.	1.46	86.23	Approved	
FMaN06			LS,LTP,GOC.	1.37	86.12	Approved	
FMaN07			LTP,GOC.	1.49	86.18	Approved	

Table 5

Performance Evaluation (continued)

Spray Technician	TE Test	Sprayed Test Part ID	Visual Inspection ^a	Mil Thickness ^{b,c}	Specular Gloss ^{d,e}	Perform Results ^f
	Pre-Window	WMaN01	PT,GOC.	1.98	81.49	Approved
		WMaN02	VGOC.	1.67	83.24	Approved
		WMaN03	PT,LA,FE.	1.87	85.33	Rejected
		WMaN04	PT,GOC.	1.58	86.78	Approved
		WMaN05	VGOC.	1.85	85.33	Approved
		WMaN06	VGOC.	1.78	85.27	Approved
		WMaN07	VGOC.	1.91	83.84	Approved
	Post-Full	FMbY01	LA,GOC.	1.64	87.22	Approved
		FMbY02	LTP,GOC.	1.84	86.83	Approved
		FMbY03	S.	1.78	87.32	Rejected
		FMbY04	VGOC.	1.48	86.98	Approved
		FMbY05	VGOC.	1.89	86.46	Approved
		FMbY06	PT,LS,GOC.	1.62	86.87	Approved
		FMbY07	VGOC.	1.40	86.63	Approved
	Post-Window	WMbN01	PT,GOC.	1.55	79.34	Approved
		WMbN02	PT,GOC.	1.74	86.16	Approved
		WMbN03	PT,GOC.	1.50	88.18	Approved
		WMbN04	LTP,GOC.	1.80	85.03	Approved
		WMbN05	VGOC.	1.91	82.53	Approved
		WMbN06	PT,SSP.	1.78	81.75	Approved
		WMbN07	HS,S.	2.05	85.45	Approved

Note. ^a See Table 2, Chapter III, for visual inspection glossary

^b Manufacturer Recommended Film Thickness: Mils Dry 1.25-1.50.

^c Research Mil Build Mean: Pre-F Parts=1.56;Pre-W Parts=1.51;Post-F Parts=1.61;Post-W=1.61.

^d Manufacturer Estimated 90 + Gloss.

^e Research Specular Gloss Mean: Pre-F Parts=82.89;Pre-W Parts=81.82;Post-F Parts=83.89;Post-W Parts=82.93.

^f Rejected Test Parts were excluded from further analysis.

^g Spray Technician "B" excluded from further analysis because of the high number of rejected parts.

^hNot Reported.

Independent Variables

All the independent variables were monitored and kept stable as possible during the course of this study. As previously mentioned, the rationale for this study was to provide a controlled environment where the spray technicians and the implementation of the Laser Touch™ targeting device during the post-tests were the critical factors. Standards and procedures were employed and followed using the American Society of Tests and Measurements (ASTM). Each instrument or piece of equipment used during this study was calibrated following the National Institute of Standards and Technology (NIST) and kept operable for data collection. All instruments and equipment specifications were found to be within manufacturer ranges.

Results of the data gathered during this study are summarized in tables below. Table 6 summarizes the variables related to the coating. Solid content, viscosity, and density were measured for each batch mixed. All of these variables were measured following ASTM standards and procedures. Table 7 summarizes the temperatures and relative humidity measured in the spray booth environment and in the facility environment. It is important to mention that this study was planned to be carried out during the fall season to reduce temperature variations which could affect the results. Table 8 summarizes the airflow measured in the north and south sides of the panels inside the spray booth. Table 9 summarizes the parameters taken into consideration to set up the manual spray gun. It includes air pressures, fluid flows, and cap air test which were considered the most critical variables. Each technician was required to set the gun up and the pattern was recorded and kept similar as possible among technicians. Appendix K shows the set up format and the recorded patterns for each spray technician.

Table 6

Controlled Independent Variables - Coating Related

Spray	% Solid Content ^a		Viscosity ^b		Density ^c	
	Pre-Test	Post-Test	Pre-Test	Post-Test	Pre-Test	Post-Test
“B” ^a	73.40%	71.85%	53.60	52.25	10.95	10.92
“C”	74.12%	73.41%	49.92	51.20	10.92	10.93
“D”	75.30%	75.20%	55.68	55.32	11.26	11.01
“E”	73.99%	73.74%	56.78	56.72	11.04	11.04
“F”	74.20%	73.85%	54.67	57.66	10.70	10.68
“G”	74.24%	74.31%	55.84	50.92	10.72	10.67
“H”	73.13%	74.19%	57.42	55.22	10.69	10.68
“I”	74.18%	72.38%	55.80	58.08	10.58	10.51
“J”	73.31%	73.37%	56.14	57.30	10.52	10.50
“K”	73.01%	74.17%	58.50	53.65	10.54	10.50
“L”	73.13%	73.72%	56.45	58.50	10.51	10.53
“M”	<u>72.57%</u>	<u>71.38%</u>	<u>53.40</u>	<u>55.98</u>	<u>10.46</u>	<u>11.11</u>
<u>M</u>	73.72%	73.46%	55.35	55.23	10.74	10.76
<u>SD</u>	0.75%	1.10%	2.25	2.66	0.25	0.23
<u>V</u>	0.01%	0.01%	5.04	7.10	0.06	0.05
<u>Min.</u>	72.57%	71.38%	49.92	50.92	10.46	10.50
<u>Max.</u>	75.30%	75.20%	58.50	58.50	11.26	11.11

Note. ^a Coat manufacturer solid content (%) recommendation 78.20.

^b Manufacturer recommended range 50-65 s. (Ford Cup # 4)

^c Calculated density reduced g/ml.

Table 7

Ambient Conditions Variables

Spray Technician	Facility Conditions				Booth Conditions			
	Temperature(°F)		Humidity(%)		Temperature(°F)		Humidity(%)	
	Pre	Post	Pre	Post	Pre	Post	Pre	Post
“B”	70	73	33	32	73	73	32	32
“C”	72	81	32	28	72	81	32	27
“D”	75	77	26	22	73	77	25	22
“E”	72	73	31	33	73	72	31	32
“F”	72	70	25	23	77	73	24	23
“G”	72	75	24	24	72	75	25	24
“H”	70	75	40	41	72	75	44	41
“I”	70	72	36	35	72	73	36	34
“J”	73	75	39	26	73	77	39	25
“K”	70	75	36	36	72	75	36	36
“L”	70	72	32	31	77	77	30	30
“M”	<u>68</u>	<u>75</u>	<u>32</u>	<u>25</u>	<u>73</u>	<u>77</u>	<u>30</u>	<u>25</u>
<u>M</u>	71.1	74.2	32.1	29.6	73.3	75.4	32	29.2
<u>SD</u>	1.85	2.81	5.18	5.94	1.82	2.54	6	5.89

Table 8

Booth Airflow Variable

Spray	North Side(fpm)		South Side(fpm)	
	Pre-Test	Post-Test	Pre-Test	Post-Test
"B"	170	160	185	155
"C"	190	170	200	170
"D"	170	110	170	110
"E"	170	150	180	160
"F"	175	150	160	150
"G"	190	160	200	150
"H"	190	145	175	160
"I"	160	180	150	160
"J"	190	150	180	140
"K"	170	160	180	150
"L"	170	175	185	180
"M"	<u>160</u>	<u>170</u>	<u>170</u>	<u>150</u>
<u>M</u>	175.4	156.7	177.9	152.9
<u>SD</u>	11.57	18.38	14.53	17.12

Table 9

Spray Gun Set-Up Variable

Spray Technician	Inlet Air Flow (# turns)		Fluid Flow (# turns)		Air Cap Pressure(PSI)	
	Pre-Test	Post-Test	Pre-Test	Post-Test	Pre-Test	Post-Test
“B”	1.125	1.125	3	3	8	7.9
“C”	1.125	2.75	2.875	1.125	NR ^a	NR
“D”	1.125	1.125	2.5	2.5	7.5	7.5
“E”	1.125	2	2.25	1.75	7.3	7.7
“F”	2.125	2.125	4	4	5.5	5.5
“G”	1.5	1.5	3.5	3.5	7	7
“H”	1.375	1.375	2.5	2.5	6.5	6.5
“I”	5.5	5.5	1.5	1.5	8.7	8.7
“J”	0.875	0.875	2	2	7.5	7.5
“K”	1.125	1.125	2.5	2.5	7	7
“L”	1.25	1.25	2.5	2.5	8.5	8.5
“M”	<u>1.5</u>	<u>1.5</u>	<u>3.5</u>	<u>3.5</u>	<u>8</u>	<u>8</u>
M	1.65	1.85	2.72	2.53	7.41	6.32
SD	1.25	1.26	0.70	0.86	0.92	0.92

Note. ^a Not Recorded

Research Question One

Did the Laser Touch™ targeting device improve the painting technique of the spray technicians as measured by transfer efficiency? The TE of each test part sprayed by the technicians was determined. An average of the seven full test parts and seven window test parts sprayed by the 12 technicians during the pre-tests was calculated. The same calculation was performed for the 12 post-test parts sprayed by the technicians. The difference between the pre-tests and the post-tests was then obtained. The average of the differences was computed and analyzed to determine the improvement in TE. Table 10 shows the pre-test and post-test TE and the arithmetic differences. Also, the table shows mean and standard deviation calculation, for the 12 spray technicians tested. From this data, the ability of spray technicians of improving TE using the Laser Touch™ targeting device was evaluated.

As this preliminary analysis indicated, TE in the post full parts data and in the post window parts data shows an increase. A total of + 5.03% in average difference TE of full parts between the pre-test and the post-test was achieved by the 12 spray technicians tested. Only two of them did not show a significant difference; however, the remaining of the technicians achieved an acceptable difference in TE. Eight out of the ten differences in TE were classified as an excellent rating. Regarding the window parts, an average difference between the pre-test and the post-test was computed as much as + 6.22%. Despite the fact that three of the spray technicians did not attain an acceptable TE difference, the remainder achieved an excellent TE difference rating. The results indicated an overall improvement of + 11.11% from the baseline after computing the percent improvement for the total parts sprayed.

Table 10

Spray Technician Pre and Post Transfer Efficiencies and Differences

Spray Technician	Full Part Transfer Efficiency			Window Parts Transfer Efficiency		
	Pre-Test	Post-Test	Diff. ^a	Pre-Test	Pos-Test	Diff. ^a
“B” ^b	76.57%	77.41%	0.83	58.54%	68.22%	9.67
“C”	70.25%	78.96%	8.71	48.44%	57.15%	8.71
“D”	72.83%	76.53%	3.70	47.96%	57.72%	9.75
“E”	72.86%	73.37%	0.51	49.67%	49.04%	(-0.63)
“F”	61.67%	71.49%	9.82	35.89%	50.24%	14.35
“G”	71.01%	75.92%	4.92	52.87%	54.36%	1.49
“H”	80.67%	80.36%	(-0.30)	64.94%	64.47%	(-0.55)
“I”	64.36%	68.73%	4.37	37.83%	45.27%	7.44
“J”	75.20%	80.98%	5.79	53.96%	58.49%	4.53
“K”	76.16%	74.15%	(-2.01)	56.53%	55.61%	(-0.92)
“L”	69.58%	75.67%	6.09	45.74%	54.19%	8.45
“M”	62.31%	76.02%	13.70	42.15%	57.84%	15.69
<u>M</u>	<u>71.12%</u>	<u>75.80%</u>	<u>5.03</u>	<u>49.54%</u>	<u>56.05%</u>	<u>6.22</u>
<u>SD</u>	<u>5.93%</u>	<u>3.68%</u>	<u>-----</u>	<u>8.40%</u>	<u>5.25%</u>	<u>-----</u>
<u>V</u>	<u>0.35%</u>	<u>0.13%</u>	<u>-----</u>	<u>0.70%</u>	<u>0.27%</u>	<u>-----</u>
<u>Min.</u>	<u>61.67%</u>	<u>68.73%</u>	<u>-----</u>	<u>35.89%</u>	<u>45.27%</u>	<u>-----</u>
<u>Max.</u>	<u>80.67%</u>	<u>80.98%</u>	<u>-----</u>	<u>64.94%</u>	<u>64.47%</u>	<u>-----</u>

Note. ^a Full Parts Improvement=7.57%; Window Parts Improvement=14.66%; Avg. Improvement Total Parts=11.11%.

^b Excluded from the statistical analysis due to excessive runs and sags found on sprayed test parts, thus, TE was calculated.

From this primary analysis, the descriptive statistic indicated there is improvement in TE when implementing the Laser Touch™ targeting device in manual spray guns for this particular sample.

Thus, to determine the level of significance of the primary results, a one tail t-test was calculated to determine whether a significant difference between the means existed. The measure was the difference between the pre-test and the post-test data means ($\mu_{pre} - \mu_{post} = \mu_D$). Because it was intended to determine if the post test data was different from the pre test data ($\mu_{post} > \mu_{pre}$) the hypotheses tested were:

$$H_0: \mu_D = 0 \quad ; \quad H_a: \mu_D > 0$$

Therefore, this study used the following formula:
$$t = \frac{\bar{X}_D - \mu_D}{s_D / \sqrt{n_D}} \quad ;$$

The test was conducted for the difference between the pre-full and post-full parts and for the difference between the pre-window and post-window parts. The results are illustrated below in Tables 11 and 12, and computed using the data analysis tools provided by Microsoft Excel 2000.

Table 11

t-Test: Paired Two Set of Data for Means - Full Parts

	<i>POST-TEST</i>	<i>PRE-TEST</i>
Mean	0.756531398	0.706272451
Variance	0.001353216	0.003522172
Observations	11	11
Hypothesized Mean Difference	0	
df	10	
t Stat	3.603231268	
P(T<=t) one-tail	0.002410985	
t Critical one-tail	1.812461505	

From the statistical analysis, it was observed that the p -value (Table 11) of the full parts paired two set of data means analysis was smaller ($p = 0.0024$) than the significant level. Also, the t statistic was computed to be high ($t = 3.60$) and fell out of rejection region. As a result, the null hypothesis ($H_0: \mu_D = 0$) was rejected and it was concluded that there was enough evidence at the $\alpha = 0.05$ significance level to infer that $\mu_D > 0$.

Consequently, the same criterion was applied to analyze the differences between the two paired sets of data for the window parts. The t statistic was computed to be high ($t = 3.49$) which again fell out of the rejection region. It indicated that there was enough evidence to reject the null hypothesis ($H_0: \mu_D = 0$). In conclusion, the results supported the alternative hypothesis ($\mu_D > 0$) at the $\alpha = 0.05$ significance level, indicating that there was a significant difference between pre-test results and post-test results. Table 12 shows the t -test analysis for the test window parts.

Table 12

t-Test: Paired Two Set of Data for Means - Window Parts

	<i>POST-TEST</i>	<i>PRE-TEST</i>
Mean	0.549426644	0.487254763
Variance	0.002759554	0.007056357
Observations	11	11
Hypothesized Mean Difference	0	
df	10	
t Stat	3.491410477	
P(T<=t) one-tail	0.002904649	
t Critical one-tail	1.812461505	

Multiple regression. The t test and the internal estimator analysis indicated that there is a significant difference between the pre TE means and the post TE means, a multiple regression analysis was carried out to extract causal information of the independent variables relationship to TE. As mentioned before, the gun set up variable was left to the technicians so that they controlled the inlet air pressure, fluid flow, and the spray pattern preferences. Each spray technician set up the spray gun differently and it was assumed that this specific variable had an effect on the resultant TE. Therefore, multiple regression analysis was utilized to assess the individual factors effect on TE.

Multiple regression was used in order to determine the effect of individual factors on the Laser Touch™ targeting device. In addition to gun set up, other variables such as level of experience, training, and the Laser Touch™ device effect were incorporated into the model. The last two variables were treated as dummy variables which acquired only two values. In the case of the Laser Touch™ variable, the post-test took a value of one and the pre-test took a value of zero. For the training variable, technicians who had received any type of painting and coating training a value of one was assigned and technicians without training a value of zero was assigned. The equation for the multiple regression model was represented as follows:

$$\begin{aligned} \text{Transfer Efficiency} = & \alpha + \beta_1 \text{Laser Touch} + \beta_2 \text{Experience} + \beta_3 \text{Gun Air Flow} \\ & + \beta_4 \text{Gun Fluid Flow} + \beta_5 \text{Training} + \epsilon \end{aligned}$$

The model was evaluated to test how well it fits the data. The required conditions to evaluate regression analysis models were tested. The conditions of normality, homoscedasticity, and multicollinearity were met resulting in a satisfied fit-model. Table 13 Shows the results of the

multicollinearity condition indicating the coefficients of correlation between the dependent and independent variables.

Table 13

Multicollinearity Test for The Multiple Regression Analysis Model

Variables	1	2	3	4	5	6	7	8
1. TE-Full	—							
2. TE-Window	.92	—						
3. Laser	.45	.43	—					
4. Experience	.08	0.004	0.004	—				
5. Booth Air Flow	(-.02)	(-.17)	(-.62)	.08	—			
6. Gun Air Flow	(-.52)	(-.52)	.05	.37	(.05)	—		
7. Gun Fluid Flow	(-.09)	.06	.05	(-.56)	.05	(-.34)	—	
8. Training	.02	.04	.12	.37	.08	.36	(-.26)	—

Since the model fit satisfactorily, the researcher proceeded to evaluate the coefficients of the model. The multiple regression analysis model was run using Microsoft Excel 2000. The results of the regression analysis are presented in Table 14. The value of the standard error ($SE = 0.034$) confirmed that the model was satisfactory since its magnitude regarding the sample mean was relatively small. The coefficient of determination measured the effect that the uncontrolled independent variables had over the TE. Its value ($R^2 = 62.8\%$) indicated that

approximately 62.8% of the variation in TE was explained by the independent variables. The remaining percentage, 37.2% of the variation was attributed to other factors.

All of this information was also supported by the value of the F-test ($F = 5.4$) because it was moderately large. Therefore, it indicated that the variation in TE was explained by the regression equation. In addition, the p value ($p = 0.004$) of the F test indicated that there was a strong evidence to infer that the model was valid. The coefficient β_1 described the relationship between the Laser Touch™ and the TE. The value of $\beta_1 = 0.046$ indicated that there was a strong relationship ($t = 3.123$; $p = 0.006$) between the TE and the Laser Touch™.

Table 14

Multiple Regression Analysis - Transfer Efficiency Full Parts

Regression Statistics						
Multiple R	0.792536254					
R Square	0.628113714					
Adjusted R Square	0.511899249					
Standard Error	0.034668218					
Observations	22					
ANOVA	df	SS	MS	F	Significance F	
Regression	5	0.032479634	0.0065	5.40478086	0.00424144	
Residual	16	0.019230165	0.0012			
Total	21	0.051709799				
	Coefficients	Standard Error	<i>t Stat</i>	<i>P-value</i>	Lower 95%	
Intercept	0.795247319	0.043438143	18.308	3.7233E-12	0.703162591	
Laser	0.046878993	0.015011429	3.123	0.006558	0.015056191	
Experience	0.000870003	0.000989255	0.8795	0.39217326	-0.001227124	
Gun Air Flow	-0.027976805	0.006651054	-4.21	0.00067	-0.042076406	
Gun Fluid Flow	-0.016967346	0.013022864	-1.3029	0.21105299	-0.044574579	
Training	0.010653727	0.017251535	0.6176	0.54556013	-0.025917886	

Regarding the TE of the window parts, the model was used for the same independent variables. In this case, only the dependent variable was changed from TE full parts to TE window parts. The model was run again using this new configuration. New results are presented in Table 15. It was observed that the coefficient of determination ($R^2 = 55.2$) was moderately high which indicated that 55.2% of the variations found in the window parts TE was explained by the independent variables included in the model.

Table 15

Multiple Regression Analysis - Transfer Efficiency Window Parts

Regression Statistics						
Multiple R	0.743170823					
R Square	0.552302872	t Stat				
Adjusted R Square	0.41239752					
Standard Error	0.061184348					
Observations	22					
ANOVA	df	SS	MS	F	Significance F	
Regression	5	0.073891359	0.014778	3.947689	0.015972554	
Residual	16	0.059896392	0.003744			
Total	21	0.133787751				
	Coefficients	Standard Error	t Stat	P-value	Lower 95%	
Intercept	0.565009725	0.076661987	7.370142	1.58E-06	0.40249361	
Laser	0.069670706	0.026492984	2.62978	0.0182	0.013508102	
Experience	0.001352911	0.001745891	0.774912	0.449693	-0.002348211	
Gun Air Flow	-0.042597764	0.011738141	-3.629	0.00226	-0.067481505	
Gun Fluid Flow	-0.007224305	0.022983456	-0.314326	0.757335	-0.055947045	
Training	0.025374616	0.030446444	0.833418	0.416878	-0.0391689	

The p value ($p = 0.01$) of the F test indicated a significant evidence to imply that the model was valid. On the other hand, it was observed that the coefficient of the Laser Touch™ variable

($\beta_1 = 0.069$) support the hypothesis of better TE using the Laser Touch™. This value indicated that once the Laser Touch™ was attached to manual spray guns it was expected to have an improvement. From this analysis it is concluded that the Laser Touch targeting device improves the transfer efficiency of the system.

Research Question Two

Did the Laser Touch™ targeting device minimize paint consumption as measured by pre-test and post-test paint usage? The arithmetic means of the gallons of paint sprayed by the technicians during the pre-test and post-test are reported in Table 16. The data indicated a difference between the pre-test mean and the post-test mean of 0.01 gallons for the full parts. For the window parts, the data indicated a difference between pre-test mean and post-test mean of 0.02 gallons. These results were achieved taking into consideration the entire sample. In order to determine if there was any significant difference between the two means, a similar statistical technique was employed. A one tailed t test was performed to determine the significant difference between the pre-test and the post-test paint consumption means. The t value of -2.55 was found to be significant ($p = 0.008$). It means that there was a strong evidence that the pre-test and the post-test paint consumption means are different.

Likewise, a multiple regression analysis technique was established to draw conclusions about the population mean. The objective was to determine the factors affecting the paint consumption and hold the other factors constant. The equation for the multiple regression model was as follows:

Table 16

Gallons of Paint Used

Spray Technician	Full parts		Window Parts	
	Pre-Test	Pos-Test	Pre-Test	Post-test
“B” ^a	0.125	0.126	0.086	0.077
“C”	0.161	0.166	0.150	0.130
“D”	0.214	0.244	0.159	0.154
“E”	0.145	0.148	0.095	0.105
“F”	0.186	0.136	0.151	0.124
“G”	0.164	0.149	0.088	0.118
“H”	0.232	0.205	0.126	0.111
“I”	0.204	0.223	0.176	0.145
“J”	0.196	0.178	0.140	0.135
“K”	0.212	0.183	0.112	0.108
“L”	0.252	0.197	0.169	0.145
“M”	<u>0.248</u>	<u>0.185</u>	<u>0.256</u>	<u>0.117</u>
<u>M</u>	0.19	0.18	0.14	0.12
<u>SD</u>	0.04	0.04	0.05	0.02

Note. ^a Incorporated in the paint consumption study.

$$\begin{aligned} \text{Paint Consumption} = & \alpha + \beta_1 \text{ Laser Touch} + \beta_2 \text{ Experience} + \beta_3 \text{ Viscosity} \\ & + \beta_4 \text{ Booth Air Flow} + \beta_5 \text{ Gun Air Flow} + \beta_6 \text{ Gun Fluid Flow} + \beta_7 \text{ Training} + \epsilon \end{aligned}$$

The evaluated conditions of normality of data, homoscedasticity, and multicollinearity were found to meet requirements. The model was assessed to find out how it fits the data. The values of the standard error (SE), the coefficient of determination (R²), and the significant of the F test (p) indicated that the model fits satisfactorily (SE = 0.031, R² = 50.9%, p = 0.03).

As the model met the required conditions and fit the data satisfactorily, it was then used to evaluate the Laser Touch™ coefficient (β₁) against the paint consumption-dependent variable. The value of the t statistic (t = -2.22) and the p value (p = 0.04) indicated that there was evidence to infer that a reduction in paint consumption using the Laser Touch™ occurred. It also indicated that the Laser Touch™ can be described in a linear relationship to the paint consumption-dependent variable. The value of the coefficient β₁ = -0.036 revealed that implementing the Laser Touch™ on manual spray guns caused a reduction of 0.036 gallons of paint. Thus, for every 1 gallon of paint sprayed a reduction of 0.18 gallons can be attained. From the result of this statistical analysis, it was concluded that the Laser Touch™ targeting device is an effective production tool for minimizing paint consumption in painting and coating operations for the manufacturing industry.

Research Question Three

Did the Laser Touch™ targeting device reduce VOC's emissions as measured by pounds of VOC's released into the air by pre-test and post-test? The arithmetic means of the pounds of

volatile organic compound released during the study by the technicians was calculated. The data is presented in Table 17. It indicated to some degree a reduction of VOC emissions using the Laser Touch™ targeting device.

Table 17

Pounds of Volatile Organic Compound Released

Spray Technician	Full parts		Window Parts	
	Pre-Test	Pos-Test	Pre-Test	Post-test
“B” ^a	0.36	0.39	0.25	0.24
“C”	0.45	0.48	0.42	0.38
“D”	0.60	0.67	0.44	0.42
“E”	0.42	0.43	0.27	0.30
“F”	0.51	0.38	0.42	0.35
“G”	0.45	0.41	0.24	0.32
“H”	0.67	0.56	0.36	0.31
“I”	0.56	0.65	0.47	0.42
“J”	0.55	0.50	0.39	0.38
“K”	0.60	0.50	0.32	0.29
“L”	0.71	0.55	0.48	0.40
“M”	0.71	0.59	0.73	0.37
<u>M</u>	0.55	0.51	0.40	0.35
<u>SD</u>	0.20	0.10	0.13	0.06

Note. ^a Incorporated in the Paint Consumption Study.

A one tailed t -test was computed to assess the difference between the paired test means. The test reported a value of $t = -5.07$ and it was found to be significant ($p = 0$), suggesting a significant difference between the pre-test and the post-test means for VOC's. A multiple regression analysis was then performed to determine critical factors affecting VOC emissions. A mathematical equation with similar characteristics to the one used to evaluate the previous research question was applied.

The coefficient of determination was found to be moderately good ($R^2 = 55.31\%$ and adjusted $R^2 = 35.76\%$) and the p value of the F test was 0.04, which indicated that the model fit satisfactorily. There was evidence to suggest that the VOC emissions and the Laser Touch™ were linearly related ($t = -1.93$; $p = 0.07$). The relationship between VOC emissions and the Laser Touch™ was explained by the coefficient β_1 . The value of $\beta_1 = -0.08$ indicated that implementing the Laser Touch™ on manual spray guns, the VOC emissions decrease by 0.08 lb. It was assumed that the other independent variables in this model were held constant. In other words, it could be said that for each additional 10 pounds of VOC released, a reduction of 14.5% could be achieved. From the result of this statistical analysis, it can be concluded that the Laser Touch™ targeting device is an effective production tool for reducing VOC's emissions in painting and coating operations for the manufacturing industry.

Research Question Four

Was the Laser Touch™ targeting device an effective production tool for improving finish quality in painting and coating operations for the manufacturing industry? For this study the two

parameters used to define quality were the mil thickness and the specular gloss. As it was described before, the parts were evaluated in the basis of twelve points that were consistently measured with a predefined template. The mil thickness and the gloss averages of each part were presented in Table 5. The statistical data is shown in Table 18.

The data indicated an increase in mil thickness from pre-test to post-test. The paint manufacturer data sheet recommended a thickness range between 1.25 to 1.50 mils. This slight increase in mils may have been caused by a better overlap and edges cover found in the post-test parts. A better coating coverage was observed on the post-test parts in the visual inspection phase.

Table 18

Descriptive Statistics for Mil Thickness and Specular Gloss Readings

	Mil Thickness(mills)				Specular Gloss(units)			
	Full Parts		Window Parts		Full Parts		Window Parts	
	Pre	Post	Pre	Post	Pre	Post	Pre	Post
<u>M</u>	1.56	1.61	1.51	1.61	82.89	83.89	81.82	82.93
<u>SD</u>	0.26	0.30	0.22	0.22	2.57	2.96	5.65	3.31
<u>Min</u>	1.12	1.07	1.18	1.32	77.66	75.99	65.12	73.73
<u>Max</u>	2.04	2.11	1.80	2.08	86.01	86.83	85.44	85.37

As for specular gloss, the test parts reached an overall satisfactory light reflection. The paint manufacturer data sheet established that this specific coating is capable to achieve a measure of 90+ in gloss readings. The data indicated that using an application geometry of 20° gave the post-test parts better specular gloss readings. From this, a slight difference of one gloss unit between pre-test and post-test made it difficult to conclude that an improvement on specular gloss occurred.

The data was analyzed to assess the difference between the pre-test and post-test mean for specular gloss. A t test was conducted to determine if a significant difference exists for the mil thickness and for the specular gloss data set. The t test for the mil thickness revealed no significant difference between the pre-test and the post-test means ($t = 0.1$; $df = 23$; $p = 1.33$). Regarding the t -test for the specular gloss, the p value of the t ($t = 1.04$) test was found to be non-significant ($p = 0.15$), suggesting no significant differences between the means.

Little information about the finish quality could be extracted from this information. Only the visual inspection of surface appearance reported the state of the coating as good. Because of the limitations of evaluating the quality of the coating on the parts a conclusion about the effects of the Laser Touch™ in finish quality was not reported here.

CHAPTER V

SUMMARY, CONCLUSION, AND RECOMMENDATIONS

This chapter presents a general overview of the procedures and methodology employed to carry out the study. In addition, it outlines the purposes and objectives of the study as well as it describes briefly the literature review. Moreover, a report of the findings of this study is summarized, together with the conclusions and recommendations for future studies.

Summary

This study was conducted to evaluate the Laser Touch™ targeting device in terms of increased TE, reduction in paint consumption, and volatile organic compound emissions, and improvement in finish quality. Considering the impact that the painting and coating pollutants have on the environment, new approaches in painting and coating technologies need to be developed. These new technologies are needed for the paint and coating manufacturers of materials and equipment. It also encloses manufacturer companies handling these materials and equipment, as well as the final user, and the most important piece in the spray system, the technician.

The literature review of this study was focused on previous studies related to the performance and improvement of spray systems in painting and coating operations. Studies indicated that spray technicians were a key factor in painting and coating operations. Many authors agreed that spray technicians are capable of achieving 50 to 100% efficiencies in spraying processes. Training and the development of pollution prevention tools will enable spray

technicians to obtain better Transfer Efficiency ratios. Chapter II described the extensive work carried out to improve spray systems.

The Laser Touch™ targeting device has been developed as a pollution prevention tool to assist technicians in the spray process. It was hypothesized that this tool increases the transfer efficiency of the system once attached to manual spray guns. It was also believed that this tool will generate saving in paint consumption, reduce VOC's emissions, and improve the finish quality of the coating.

Thus, an experimental study was done to collect data to answer the research questions. The study was limited to small manufacturing applications and included a specified type of gun and coating material. A controlled environment was used for Laser Touch™ device testing. The Laser Touch™ targeting device and the spray technicians were the critical elements of this study. Therefore, the study sought to show that implementing the Laser Touch™ targeting device as a tool could reduce pollution in painting and coating operations for the manufacturing industry.

A pre-experimental research method was employed in this study. The design involved only one group which was pre-tested, exposed to a treatment, and post-tested. The rationale was to compare and analyze pre-test and post-test data to determine the Laser Touch™ targeting device benefits. The population for this study consisted in 12 spray technicians from the north-east area of the state of Iowa. All of them worked in manufacturing. Seven technicians had less than three years of experience and five had more than 18 years of experience.

The methodology of this study followed established ASTM standards and procedures. Spray technicians sprayed two types of test parts. Seven full test parts for run one and seven window parts for run two were sprayed by the technicians. The study comprised 14 test parts for

the pre-test (group 1) and 14 test parts (group 2) for the post-test. An industrial coating and a standard industrial spray gun were employed for the spraying process. A batch of paint was mixed for group one and a different one for group two. The batches of paint were mixed using the same ratio. ASTM standards for viscosity, solid content, and density of paint were used, measured and recorded.

Test parts were weighed before and after the spray process to determine the TE. Each part was submitted to a mil thickness test, and specular gloss test, and inspected visually to assess finish quality. Data was gathered, recorded, tabulated, and analyzed statistically using Corel Quattro Pro 2000 and Microsoft Excel 2000. The findings of this study are reported in chapter IV.

Conclusions

The problem of this study was to evaluate the degree of improvement and benefits that the Laser Touch™ targeting device can produce for painting and coating operations in the manufacturing industry. Therefore, based on the findings obtained in this research, the following conclusions were drawn:

Conclusions Related to Research Question One

Did the Laser Touch™ targeting device improve the painting technique of the spray technicians as measured by transfer efficiency? It can be concluded that the Laser Touch Targeting™ device improves the efficiency of the spray system. The regression analysis indicated a positive linear relationship between TE and the Laser Touch™ targeting device ($\rho = 0.006$).

The results of this study supports research question one. The results also indicated that if a HVLP

gun manufacturers' claims 65% TE, attaching the Laser Touch™ to spray guns can achieve approximately 70% TE rate. Also, it can be stated, that for more complicated parts, a greater improvement in transfer efficiency can be achieved. Therefore, it can be stated that the Laser Touch™ targeting device improves the TE of a spray system.

Conclusions Related to Research Question Two

Did the Laser Touch™ targeting device minimize paint consumption as measured by pre-test and post-test paint usage? A reduction of 0.18 gallons of paint was obtained spraying one gallon of paint with the Laser Touch™ attached to the gun. Thus, the regression analysis indicated that paint consumption and the Laser Touch™ targeting device had a linear relationship ($\rho = 0.02$).

The results indicated that almost 20% paint consumption reduction can be attained with the Laser Touch™ targeting device. Also, it was inferred that using the Laser Touch™ to spray parts with awkward shapes result a substantial reduction in gallons of paint. Therefore, it is concluded that the Laser Touch™ targeting device is an effective production tool for minimizing paint consumption in painting and coating operations for the manufacturing industry.

Conclusions Related to Research Question Three

Did the Laser Touch™ targeting device reduce VOC's emissions as measured by pounds of VOC's released into the air by pre-test and post-test? A reduction in VOC's can be obtained using the Laser Touch™ targeting device. The regression analysis indicated that reduction in VOC's and the Laser Touch™ were somewhat related ($\rho = 0.07$). The results indicate that a reduction of 15% in VOC emissions can be attained by implementing the Laser Touch™ targeting

device in manual spray guns (HVLP). Therefore, it is concluded that the Laser Touch™ targeting device is an effective production tool for reducing VOC emissions in painting and coating operations for the manufacturing industry.

Conclusions Related to Research Question Four

Was the Laser Touch™ targeting device an effective production tool for improving finish quality in painting and coating operations for the manufacturing industry? The visual appearance test indicated a better finish quality on the test parts sprayed by the technicians using the Laser Touch™ targeting device. The t test used to evaluate the mil thickness and the specular gloss did not indicate a significant difference between the pre-test and post-test mean for finish quality. The results did not support research question four. The finish quality parameter needs further research.

From the results of this study it was demonstrated that spray technicians' performance outcomes improved after attaching the Laser Touch™ targeting device to a manual spray gun. From the researcher's perspective, the benefits of this innovative cost saving and a pollution prevention tool are positive. In general, it is concluded that the Laser Touch™ targeting device should be considered as a regular production tool for spray process improvement in the manufacturing industry.

Recommendations

The TE of the spray system is a multi-variable process which requires special attention in order to improve painting and coating operations. The spray technician plays an important role in this process and should be trained adequately to achieve acceptable TE. The finding obtained in this study have a significant implication for the manufacturing industry regarding cost saving and

pollutant reduction. Therefore, based on the findings of this study, the following recommendations are made:

1. Spray technicians should be made aware of the variables affecting TE.
2. Managers in the manufacturing industry should consider improving TE as well as environmental protection by incorporating the Laser Touch™ in their spray systems.
3. A larger study should be conducted to determine the effects of the Laser Touch™ targeting device on finish quality.
4. Future research should be conducted to determine the differences in TE of spray technicians who have had experience using the Laser Touch™ targeting device.
5. This study should be replicated in the future using a broader geographical sample and using more complex parts.
6. It is recommended that future researchers devise ways to identify and collect data regarding TE from spray technicians in a normal production setting.

REFERENCES

- Annual Book of ASTM Standards. (1998). Paint-Test for Chemical, Physical, and optical Properties; Appearance. (Vol. 06.01) West Conshohocken, PA: American Society for Testing and Materials.
- Callahan, M. S. (1995). Pollution prevention in coating application and removal. In H. M. Freeman, *Industrial Pollution Prevention Handbook* (pp. 483-494). New York, NY: McGraw-Hill, Inc.
- Clark, M. (1995, March). Getting the abc on hvlp. BodyShop Business, 14, 22-24/91-93.
- Craven, M. W. (1999, July). Applied material cost and transfer efficiency in powder coating. Metal Finishing, 34-37.
- Ewert, S. A., Felstein S. R., & Martinez T. (1993, August). Low-cost transfer-efficient paint spray equipment. Metal Finishing, 59-64.
- Gay, L. R. (1996). Educational research competencies for analysis and applications. (5th ed.). Columbus, OH: Prentice-Hall, Inc.
- Graco, Inc. (1995). Transfer efficiency, concept and theory training (321-036 6/25). Minneapolis, MN: Graco Technical Communications Department.
- Hicks, P.G., Senser, D. W., Kwok, K.C., & Liu, B. Y. H. (1993, November). Drop transfer efficiency in air paint sprays. Proceeding of the 3rd Annual ESD Advanced Coating Conference. Ann Arbor, MI: ESD, The Engineering Society.
- Hund, J. P. (1998). Spray application processes. In *Metal Finish* (vol. 96, pp. 203-218). New York, NY: Elsevier Science Inc.
- Iowa Waste Reduction Center. (1998). Laser touch [Brochure]. Cedar Falls, IA: IWRC
- Joseph, R. (1998, March). The environmental and cost benefits of painter training. Metal Finishing, 26-31.
- PPG Industries, Inc.(1998). General industrial coating application guide. Pittsburgh, PA: PPG.
- Snowden-Swan, L. (1992). Transfer efficiency and voc emissions of spray gun and coating technologies in wood finishing. Seattle, WA: Pacific Northwest Pollution Prevention Research Center.

Taylor, R. D., Cornstubble, D. R., & Kosusko, M. (1995, February). Evaluation of innovative low-volatile organic compound (voc) industrial maintenance (im) coatings. Proceedings of the 16th AESF/EPA Conference on Pollution Prevention & Control for the Surface Finishing Industry. Orlando, FL.

Trapani, M., & Bauer, R. (1994). Improving spray efficiency in automotive refinish - the overlooked factor. Cedar Falls, IA: University of Northern Iowa, Iowa Waste Reduction Center.

Triplett, T. (1995, March 24). Training target transfer efficiency. Industrial Paint & Powder, 40-42

U.S. Environmental Protection Agency. (1990). Guides to pollution prevention-the fabricated metal product industry (EPA/625/7-90/006). Cincinnati, OH: Office of Research and Development.

U.S. Environmental Protection Agency. (1996). Pollution prevention in the paints and coating industry. (EPA/625/R-96/003). Cincinnati, OH: Office of Research and Development.

U.S. Environmental Protection Agency. (1998). Self-audit and inspection guide for facilities conducting cleaning, preparation, and organic coating of metal parts. (EPA/305-B-95-002). Johnstown, PA: Enforcement and Compliance Assurance.

APPENDICES

APPENDIX "A"
(PACE FACILITY LAYOUT)

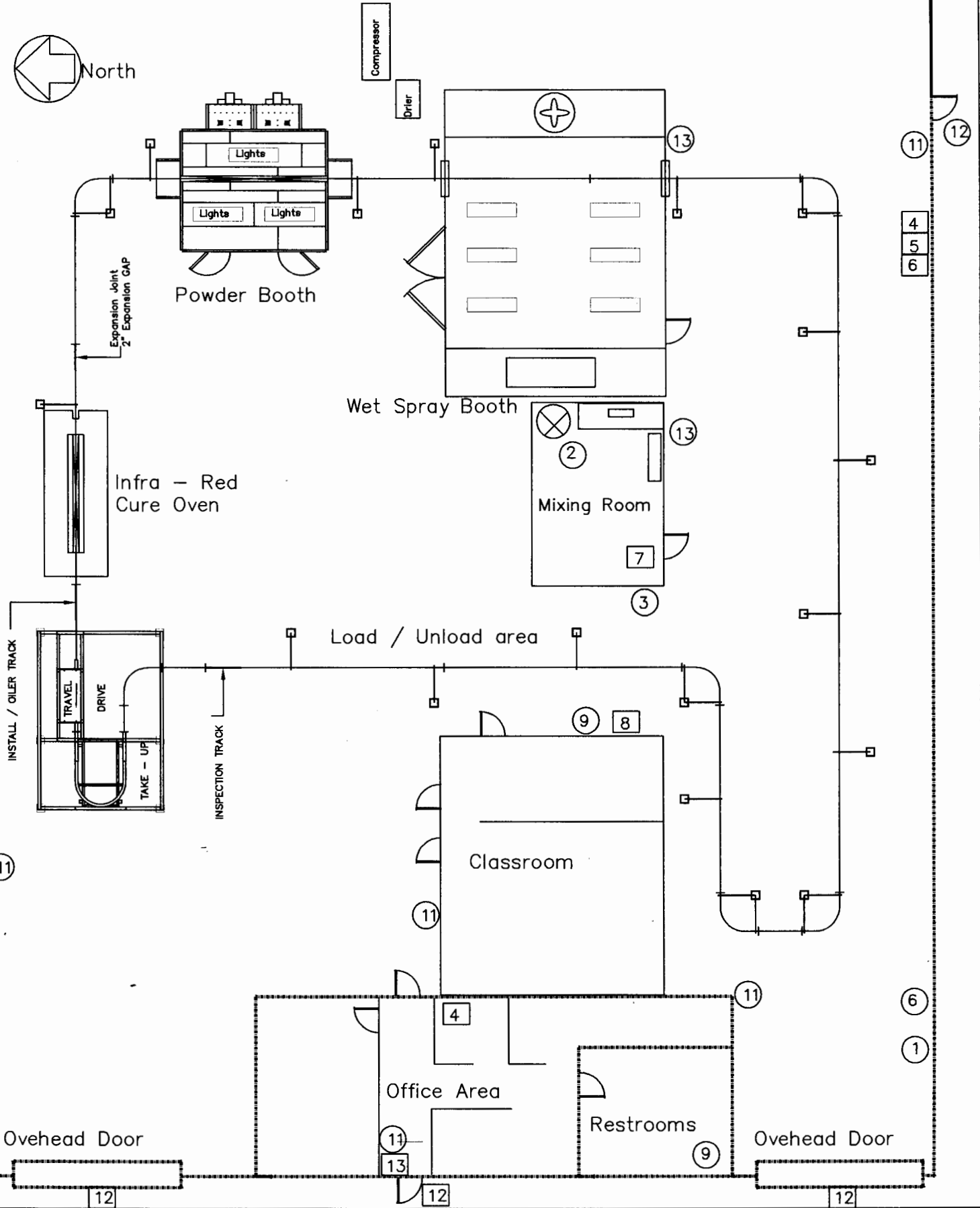

UNIVERSITY OF NORTHERN IOWA
 IOWA WASTE REDUCTION CENTER
 6114 Chancellor
 Cedar Falls, Iowa 50614-6951
 (319) 273-8905 Fax 268-3733

PACE Facility		#001	
Plan View			
REVISED	SCALE W/o scale		
DRAWING NUMBER	AI-XXX-1	1	OF 4

DATE 03/26/99 DRAWN Omar Blanco CHECKED RK SURVEY

APPENDIX "B"
(TESTING AND LABORATORY EQUIPMENT)

Equipment	Manufacturer	Model	Observations
Transmitter	Micro Motion, Inc	Elite® RFT9739	Digital Read out of mass / Volume Flow, Density, and Temperature.
Sensor	Micro Motion, Inc	Elite® CFM025	To Measure Mass/Volume Flow, Density and Temperature.
Hand-Held Spray Gun	Accuspray, Inc	AccuCharge - Series 112S or HVLP Series 10	Gun type to be determined.
Spray Booth	Binks Sames Corporation	PRF 17.5-10-T-LH	Cross-draft Air Flow.
Air Compressor	Quincy	QTH-15-120	950 RPM
Air Dryer	Airtek	TD50	Capacity 50 SCFM
Curing Oven	PED Tech., Inc	Three Zone - Contraflow	Infra-red (Reverse Convection)
Conveyor System	Rapid Industries, Inc	Rapid Flex X-348	Enclosed Track, Universal Link Chain.
Mixing Room	Saima, Inc	AccuMix MR1012	10" x 12" x 120"
Electronic Balance	Ohaus	Explorer EO2130	210 grams
Electronic Balance	Ohaus	Explorer EOL210	Bottom Loader- 22,000 grams
Laser Touch™	IWRC	LT-01	Attaches to the Spray Gun
Desiccator	Boekel Scientific	D 1380	Cabinet
Digital Timer	Control Company	Traceable® 14-648-1	Accuracy 0.01%
Coating Thickness Gage	Gardner Company Inc	DF-6001nf	Non-Ferrous
Resistivity Meter	ITW Ransburg	70408-00	To measure Paint Resistivity
Multimeter	Fluke	True RMS 87 III	Display Digital Read-out

Infra-Red Thermometer	Fluke	80T-IR	To Measure Parts Temperature
Engraver	Dremel	290	For Parts Identification
Viscosity Cup	Gardner Company Inc	VI-EZ4	# 4
Lab Oven	Quincy Lab., Inc	10 AF	Air Forced
Glossmeter	BYK-Gardner, Inc	GL-4520	micro-Tri-gloss for 20°/60°/85°
Disposable Dishes	Midland Scientific	D1600-3	Aluminum (I.D. 70 mm)
Syringes	Norm-Ject	D-78532	For Solid Content Test

APPENDIX "C"
(STANDARD TEST PARTS)

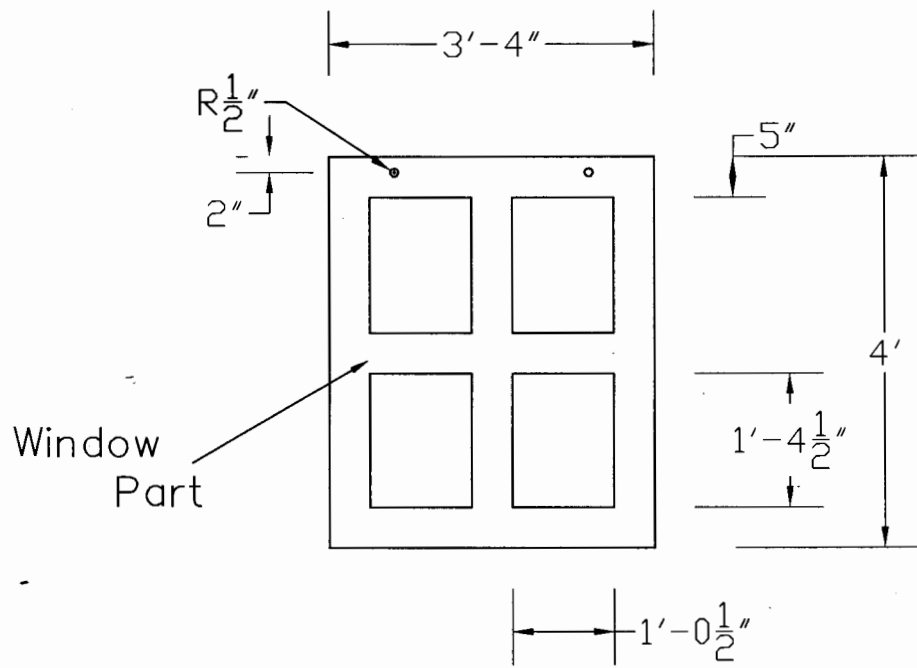
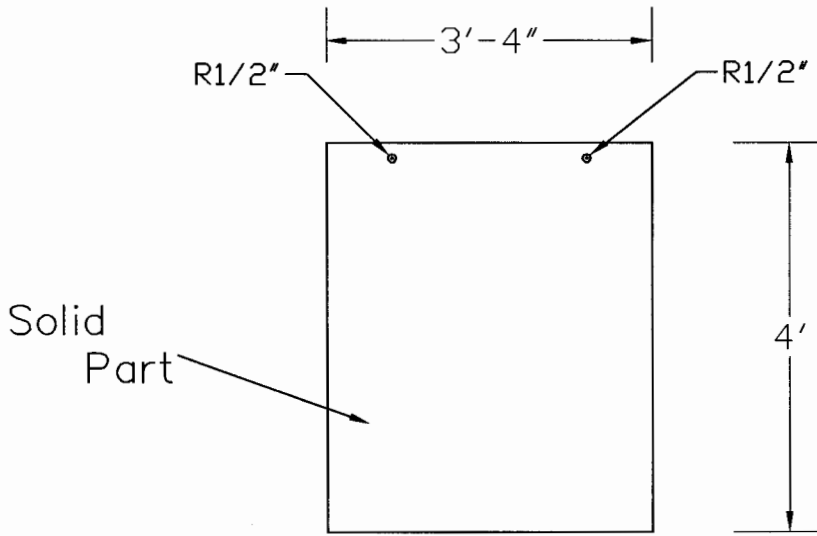

Specifications:

- Aluminum
- Thickness: 0.158 cm (0.0625 in)

UNIVERSITY OF NORTHERN IOWA			Laser Touch Research		#002
IOWA WASTE REDUCTION CENTER 1005 TECHNOLOGY PARKWAY CEDAR FALLS, IOWA 50614-6951 (319) 277-4668 Fax 268-3733			Standard Test Panels		
REVISED		ETV	SCALE 1/2" = 1'0"		
07/02/99	DRAWN Omar Blanco	CHECKED RK	SURVEY	DRAWING NUMBER Panels.dwg	2 of 4

APPENDIX "D"
(TEST SPRAY GUN SPECIFICATIONS)

ACCUSPRAY®
19 Series
HVLP Spray Gun
Owner's Manual

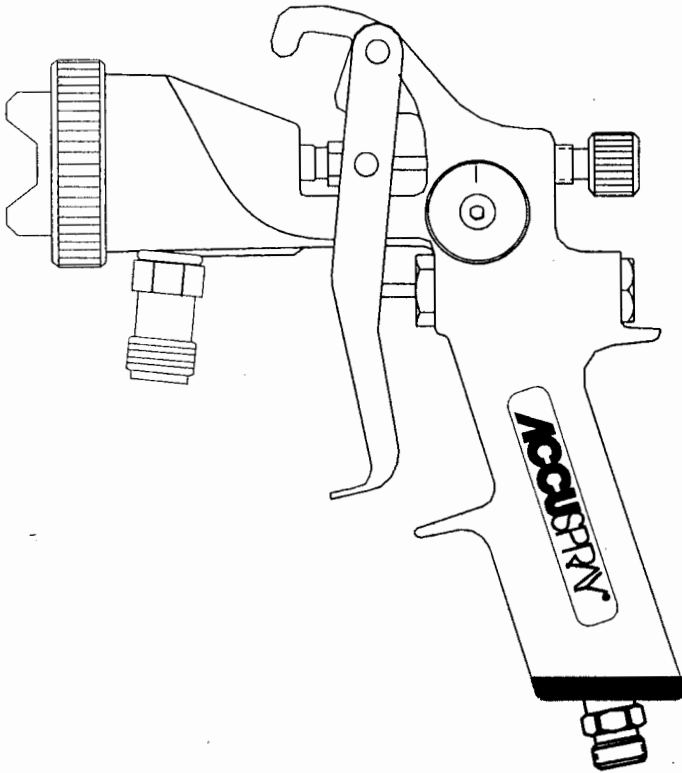

Gun Notes

1. Prior to spraying, check fluid packing adjustment and nozzle tightness.
2. Whenever you attach or detach an air hose fitting to the air inlet, use two wrenches. Always use a wrench on the air inlet to avoid breaking the internal air tube. See page 6.
3. Due to the finer atomization of your 19 Series AccuSpray gun, you may need to slow down your solvent or hardener speed.

Unpacking

Remove the components from the box. Inspect for concealed damage. If you discover any damage, contact your distributor immediately.

Table of Contents

Topic	Page Number
General Safety / Safety Precautions	3
What You Should Have	4
Set-up HVLP Gun	5
HVLP Gun Use	7
Daily Maintenance	9
Component Replacement	10
Valve Rebuild	11
HVLP Gun Parts Identification	14
Troubleshooting	15
Accessories	16

General Safety

AccuSpray's HVLP equipment is for professional use only. Hazards can occur from equipment misuse. Any misuse of the equipment or accessories, such as over pressurizing, modifying parts, using incompatible chemicals and fluids, or using worn or damaged parts can cause serious bodily injury, fire, explosion or property damage. **Please read and follow all General Safety, Safety Precautions and User Instructions.**

Never point a spray gun at anyone or any part of the body. Never place your hand or fingers in front of a spray nozzle.

Never try to stop or deflect leaks with your hand or body.

Never alter or modify any part of this equipment. A malfunction could result.

Check your spray equipment regularly. Repair or replace worn or damaged parts immediately.

Always use AccuSpray HVLP replacement parts. Only these parts were designed to work with your equipment.

Safety Precautions

Solvents and coatings can be highly flammable to combustible, especially when sprayed. Adequate exhaust must be provided to keep the air free of accumulations of flammable vapors. Smoking must never be allowed in spray areas. Fire extinguishing equipment must be present in the spray area.

Certain materials may be harmful if inhaled or if there is contact with the skin. Follow the requirements of the Material Safety Data Sheet supplied by the coating material manufacturer. Use a respirator whenever there is a chance of inhaling sprayed material. The mask must be compatible with the material being sprayed and its concentration. Safety equipment must be NIOSH approved.

Certain solvents containing Methylene Chloride and Trichloromethane are not chemically compatible with aluminum or zinc. The solvents reaction can become violent and explosive. If you are in doubt whether a coating or cleaning material is compatible, contact your material supplier.

Improper operation or maintenance may create a hazard. Personnel must be given training. Instructions and safety precautions must be read and understood. Comply with your local, state, and national codes governing ventilation, fire protection, operation, maintenance, and housekeeping.

What You Should Have

- 19 Series Gun
- One Quart Cup.....
- Cleaning Brush.....
- Gun Wrench.....

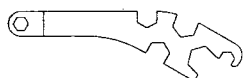

Gun Wrench
(97-047)

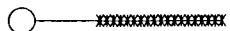

Cleaning Brush
(SH-480)

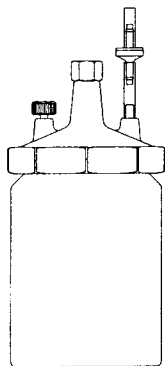

1 Quart Pressure Cup
(41-22)

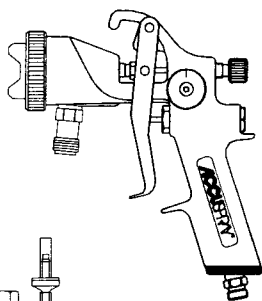

Set-up

Gun/Cup Installation

Thread the swivel nut of the cup lid onto the fluid inlet fitting of the spray gun. Tighten with an AccuSpray Gun Wrench while applying counterforce with an 1/16" wrench on the fluid inlet fitting of the spray gun.

Before fully tightening, make certain that the fluid tube is pointed forward. Attach the pressure tube from the pressure stem on the gun head to the cup lid.

Note: Spray solvent through the gun before using it for the first time.

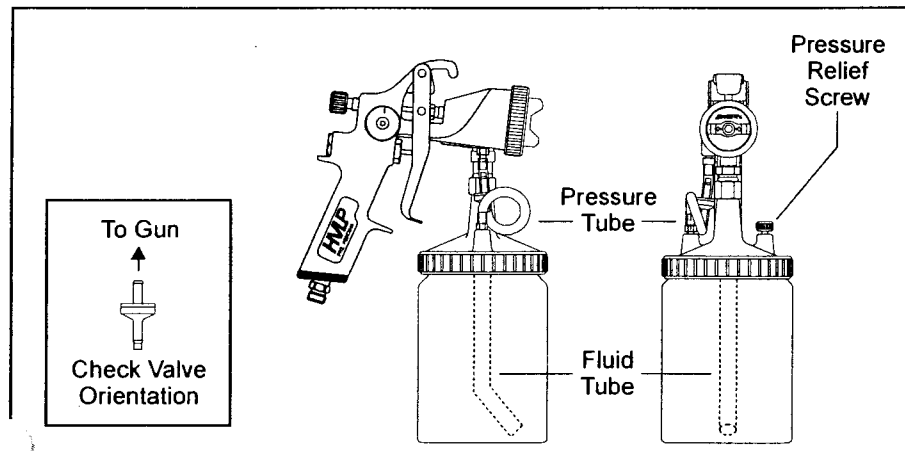

External Check Valve Assembly

To install the assembly, attach the short pressure tube hose from the check valve assembly to the gun. Loop the tube and attach it to the pressure stem of the cup. The loop plays an important role, it allows you to see any material which may be working its way back up the tube.

A properly working check valve is required for uninterrupted spraying. The advantage of the external check valve is that in its remote location (away from the paint) it is not prone to becoming jammed. The external check valve is a wear part and it will require replacement after it becomes contaminated. The normal life expectancy is from one week to three months, depending on its care.

Set-up - Continued

Attaching Your High Pressure Air Hose

When attaching your high pressure air hose (5/16" or larger) to the gun, use your gun wrench, or a 9/16" open end wrench to apply counter force to the air inlet fitting while tightening (or removing) your high pressure air hose with a 5/8" open end wrench. This will prevent damage to the air inlet tube inside the gun.

High Pressure Air

The high pressure air into the gun is decompressed inside the gun on average, at approximately a 4.5 to 1 reduction ratio. The high pressure regulator setting depends on the atomizing set and air cap selected, and the desired result. See **Guidelines for Setting Inlet Pressure** on page 8.

Caution

The fluid inlet fitting, and the air inlet fitting are **not** removable components. Do **not** remove or attempt to service the fluid inlet fitting or the air inlet fitting. If you wish to change to a quick disconnect configuration at the air inlet, adapt to the air inlet fitting and always apply counterforce to the air inlet fitting while tightening (or removing) a fitting or hose.

First Time Use

Spray solvent through the gun before using it for the first time. This will remove any contaminants that may have entered the fluid passage.

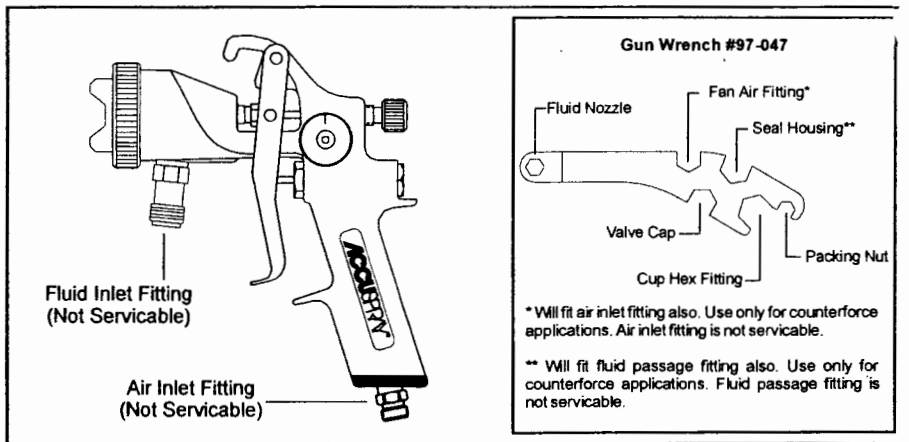

Gun Use

Gun Adjustments

The fan size is regulated by the fan adjustment knob located on the side of the gun. With the gun pointed at your target, turn the knob toward you until it stops. This is the fully closed position. Turning the knob away from you increases the fan air.

The fluid flow is controlled by the needle adjustment screw located at the rear of the gun. Turning the knob clockwise will close down the fluid flow, minimizing needle travel (trigger pull). Turning the knob counterclockwise will increase the fluid flow, maximizing needle travel (trigger pull).

With the first thread of the needle adjustment screw showing from the gun body (approximately 4 counterclockwise turns from closed) you will have full needle travel.

Please note that, when closing down the needle adjustment screw, when the needle travel has stopped, further tightening will damage the needle tip and will not aid in adjustment.

As a starting point, open the fan adjustment knob between 1/4 and 1/2 turn. Set the needle adjustment screw so that the first thread is showing from the gun body. This will give you approximately an 8 inch wide pattern, at 8 inches from your target (depending on air cap & pressure setting). Fine tuning of these adjustments will be based on your material and technique.

A small round pattern can be achieved by closing down the fan air adjustment, triggering the gun lightly, and maintaining a distance of 2 to 4 inches from your target.

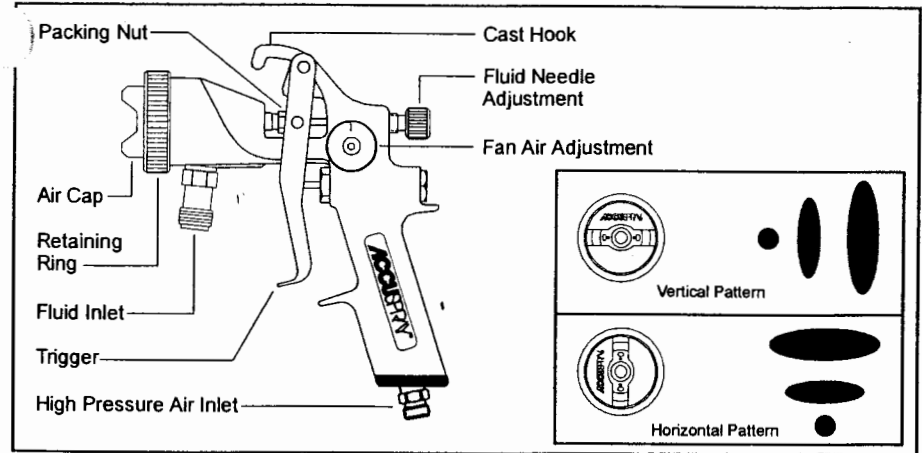

Gun Use - Continued

Spray Technique

Proper spray technique is very important to achieve a good finish. Always spray at a distance of 6 to 8 inches from your target. Keep the gun parallel to your target throughout the entire pass. More detailed spraying can be done with the gun as close as 1 inch from the target. Make sure your wrist remains firm during each pass.

Trigger the gun only after your pass begins, and release the trigger before stopping your motion. Do not angle the gun upward or downward while spraying. Angled spraying will develop an uneven paint buildup. Overlap your passes approximately 50% for an even finish.

Always be certain to thin your material with the proper solvent, and to follow the recommendations of the material's manufacturer.

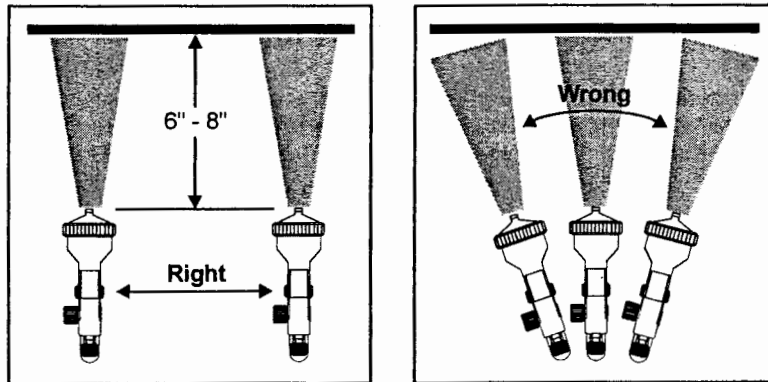

Guidelines for Setting Inlet Pressure

Lower than expected inlet pressures are used to produce excellent atomization and the desired speed of application. The chart below shows recommended starting points for setting inlet pressures at the gun.

Typical Application	Atomizing Set	Inlet Pressure Setting (at Gun)
Base Coats	.028/#5	25 - 30 psi
Medium Solids Clears	.028/#5	25 - 30 psi
High Solids Clears	.036/#6	35 - 43 psi
Single Stages	.043/#7	30 - 35 psi
Primers	.051/#9	25 - 30 psi
Stains	.028/#5	25 - 30 psi
Medium Solids Lacquers	.036/#6	35 - 40 psi
High Solids Wood Finishes	.043/#7	35 - 43 psi
High Solids Urethanes/Epoxies	.043/#7	30 - 35 psi

These are guidelines. Setups may vary due to materials and spray technique. Best results will be obtained with the gun 6 to 8" away from target. Use of a 93-103 diaphragm regulator is recommended to insure proper inlet air pressure.

Daily Maintenance

Gun Cleaning

Your AccuSpray HVLP Gun is nickel plated cast aluminum, and it contains aluminum components. Certain solvents containing Methylene Chloride and Trichloromethane are not chemically compatible with aluminum. If you are in doubt whether a coating or solvent is compatible, contact your material supplier.

It is very important to clean your gun and cup after every use. The fluid passage can be cleaned by adding a small amount of solvent to a clean cup, pressurizing the cup, and triggering the gun. Do this with the air cap removed so you may recapture the spent solvent for proper disposal.

The air cap should be cleaned by soaking, or by using a soft brush. Never use a hard tool that may damage the air cap holes. Clean the air cap holes with a wooden tooth pick or pipe cleaner. The smallest amount of damage to the air cap holes can effect the spray pattern.

Your gun and cup may be cleaned in a gun washer. Limit the time in the gun washer to a maximum of 5 minutes. Some solvent may enter through the air inlet fitting. This will not damage the gun, and the excess solvent may be blown out with air.

Lubrication

After every cleaning of the gun, you must lubricate the moving components. Cleaning washes away the lubricants that protect these friction points. Lubricate with AccuSpray Gun Lube #91-170. The lubrication points are shown below.

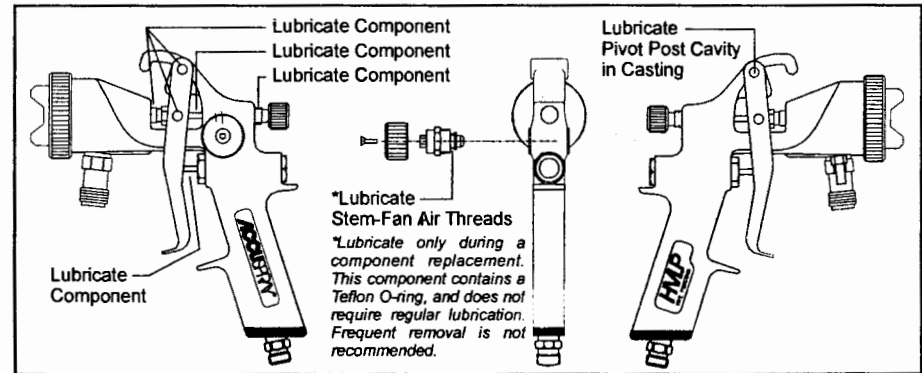

Component Replacement

With regular cleaning and lubrication, complete disassembly of your Gun should seldom be required. When it becomes time for a complete overhaul, or a part requires replacement, please follow these instructions.

General

Close your high pressure air source down. Remove your high pressure air hose remembering to always apply counterforce to the air inlet fitting (see *Set-up, Attaching Your High Pressure Air Hose on page 6*). Dispose of any paint in your cup, and flush and clean your gun (see *Daily Maintenance, Gun Cleaning*).

Fluid Nozzle, Needle Tip & Needle Shaft

With the retaining ring and air cap removed, unscrew the fluid nozzle using your Gun Wrench #97-047. Pull and hold the trigger during this to retract the Delrin needle tip. **Using the Gun Wrench prevents scoring of the fluid passage and gun body casting during replacement.**

Release the trigger and unscrew the Delrin needle tip. You can replace the needle tip at this point, remembering to retract the needle before reinstalling the fluid nozzle, or proceed with further disassembly.

To remove the needle shaft, unscrew and remove the needle adjustment screw and the needle adjustment spring. You may now pull the needle out of the gun with just your fingers. If the needle does not pull out freely, loosen the packing nut slightly. Your Gun Wrench will accomplish this with the trigger still attached to the gun.

Trigger Removal

To remove the trigger, you must have first removed the fluid needle as described above. With the fluid needle removed, locate the two E-rings on the right side of the trigger. Slide off the two E-rings with a small flat-blade screwdriver. The pivot pin (upper), and the trigger pin (lower) will now slide out to the left side of the gun, and the trigger is free to be removed. Note that left and right orientation is not critical at reassembly.

Fluid Packing Replacement

To remove and replace the fluid packing, the following must be removed first: the needle adjustment screw and spring, the fluid needle, the packing nut, and the trigger pin (lower). The trigger may remain attached to the pivot post. With these removed, insert a screwdriver with a 1/4" wide blade, and a 4" shaft into the needle shaft cavity, and press it into the fluid packing. Unscrew the packing out. **See Figure 1.**

Component Replacement - Continued

Fan Air Knob

To remove the fan air knob, and to lubricate the air stem threads, have ready a 3/64" hex key. Unscrew and remove the fan air adjustment screw using the 3/64" hex key, and lift off the fan air adjustment knob. Using your Gun Wrench, unscrew and remove the fan air fitting from the gun body. This will lift out from the gun body as a subassembly.

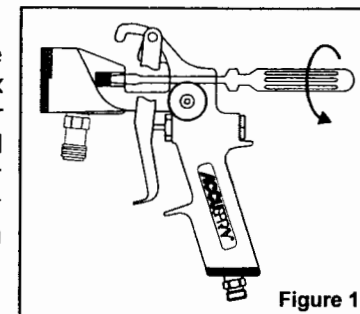

Figure 1

The threads of the fan air stem may now be lubricated with AccuSpray Gun Lube #91-170, the subassembly may be replaced, or proceed with further disassembly. The subassembly consists of the following: **see Figure 2.**

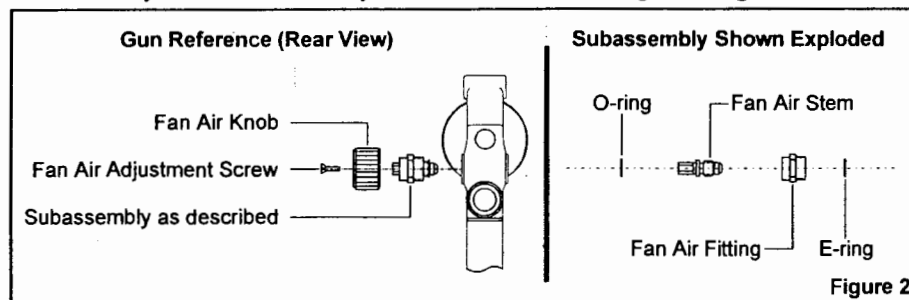

Figure 2

The subassembly may now be disassembled by first removing the E-ring from the fan air stem, with a small flat-blade screwdriver. With the E-ring removed, back out the fan air stem from the fan air fitting. The O-ring may now be removed and replaced, and the subassembly can be reassembled, and placed back into the gun body.

Valve Rebuild

With regular cleaning and lubrication, complete disassembly of your Gun should be seldom required. Good lubrication practices should be in place to ensure this.

Valve rebuild is a two step procedure. Step one involves the removal and replacement of the valve spring. You would do this if you were experiencing a sluggish trigger return. To remove the valve spring, unscrew and remove the valve cap with your Gun Wrench. **See Figure 3.** At this stage, you can also remove and replace the O-ring for the valve cap. For complete valve rebuild instructions, continue reading.

Component Replacement - Continued

Step two involves completely removing the valve from the gun body. Before you can proceed, the needle shaft and the trigger must be removed. We will also assume that the valve cap, the valve spring, and the O-ring have already been removed. **See Figure 3.**

Grasp the valve stem and pull it forward. Note that the removal of the valve stem cap is not required. Removal and replacement of the valve stem cap will be covered later in this supplement. The valve stem will pull out from the valve seat, and out of the gun through the seal housing.

The valve seat can be removed from the gun by gently reinserting the valve stem into the seal housing to "unseat" the valve seat. The valve seat will drop out of the valve cavity. **See Figure 3.**

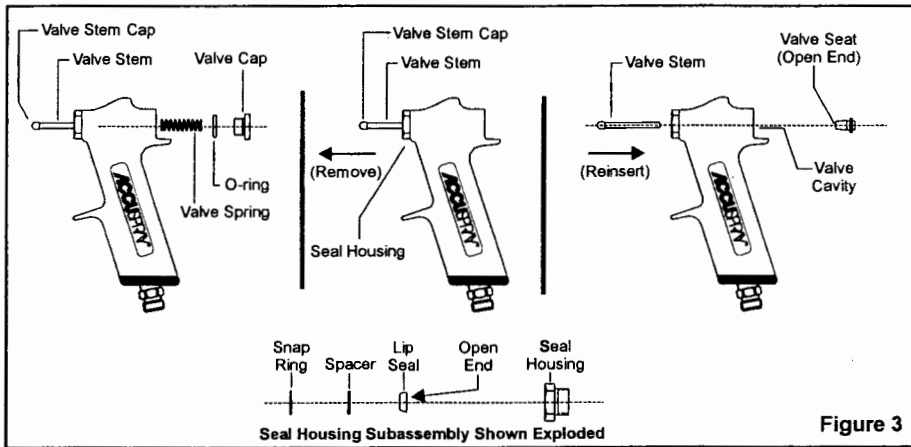

Figure 3

Seal Housing Replacement

Using your Gun Wrench, unscrew and remove the seal housing. The seal housing subassembly contains an internal snap ring. This is the only area that a special tool is required. The snap ring requires a size 100 tool. With the snap ring removed, lift out the spacer, the lip seal, and clean the seal housing cavity.

Before reassembling the seal housing subassembly, note the orientation of the lip seal. The open end of the lip seal is to be placed into the seal housing. Pack the seal housing with petroleum jelly. The lip seal will be properly installed when you feel a positive lock, and it is resting level. Reinstall the spacer and the snap ring. **See Figure 3.**

Valve Stem and Valve Seat Replacement

Drop a new valve seat into the valve cavity (open end down) **See Figure 4.** Gently press down on the valve seat to align it in the cavity. A long thin object such as a pen works well for this. Next, reinstall the O-ring, valve spring, and valve cap.

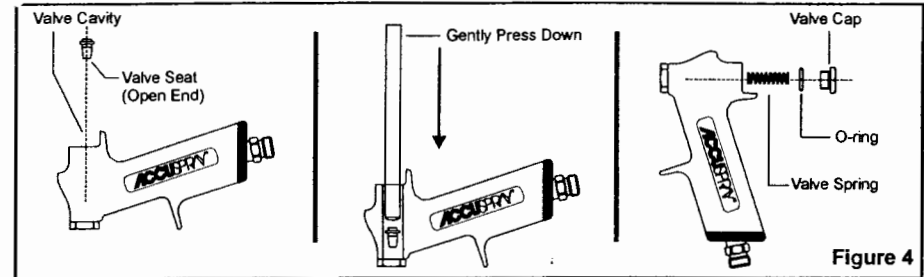

Figure 4

Next, gently push the valve stem back into the valve seat through the seal housing. **See Figure 5.** You will know that the installation is correct and complete when the spring return action is smooth. As a final seating procedure, depress the valve stem as far back as it will go, and then release it. Lubricate the valve stem with AccuSpray Gun Lube #91-170.

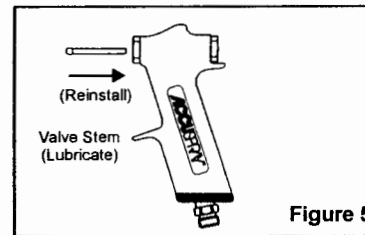

Figure 5

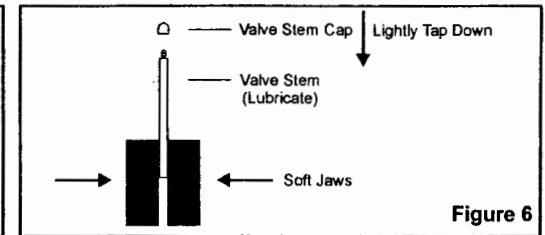

Figure 6

Valve Stem Cap Replacement

To remove the valve stem cap, remove the valve stem from the gun. Place the valve stem in a vice equipped with soft jaws. With pliers, pull the valve stem cap away from the valve stem. Be careful not to score or bend the valve stem with the pliers.

To replace the valve stem cap, leave the valve stem in the vice equipped with soft jaws. Hold the valve stem cap with needle nose pliers, and lightly tap it down with a wooden or rubber mallet. The valve stem cap will seat onto the shoulder of the valve stem. **See Figure 6.**

The valve stem may now be placed back into the gun. Please follow the instructions for Valve Stem and Valve Seat Replacement when doing this. Note: Always replace a valve stem cap with a new one. During this procedure, be careful not to bend or score the valve stem. The trigger and remaining components may now be reassembled, and your gravity gun is ready to be placed back into service.

HVLP Gun Parts Identification

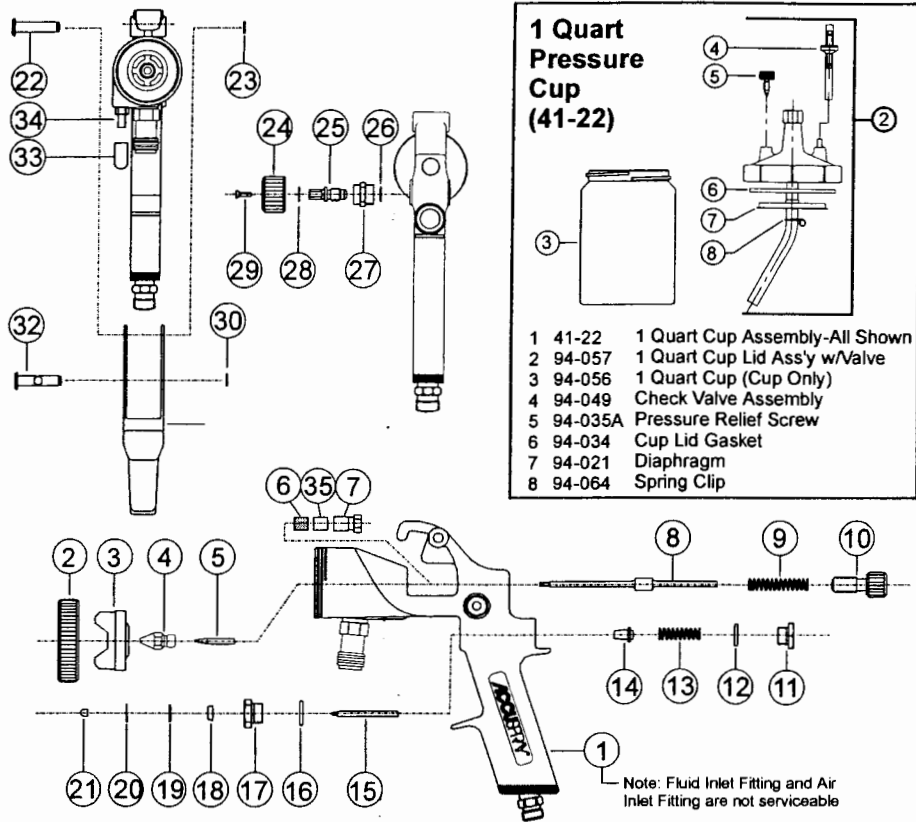

HVLP Gun Parts Identification					
Item	Part Number	Description	Item	Part Number	Description
1	98-004	Gun Handle	19	97-026	Spacer
2	91-043	Retaining Ring	20	UH-1107	Snap Ring
3	91-071-XX	Air Cap	21	91-153	Cap - Valve Rod
4	91-008-XX	Fluid Nozzle	22	97-038	Pin - Trigger Pivot
5	91-107-XX	Needle Tip	23	UH-1108	E - Clip
6	91-001	Fluid Packing	24	97-040	Knob - Fan Air
7	91-023	Packing Nut	25	98-011	Stem - Valve
8	98-009	Needle Shaft	26	UH-1108	E - Clip
9	97-021	Spring - Needle Return	27	97-043	Fitting - Fan Air
10	97-023	Screw - Needle Adjustment	28	UH-1111	O-ring
11	97-034	Cap - Valve	29	UH-831	Screw
12	UH-1106	O-ring	30	UH-1108	E - Clip
13	97-032	Spring Valve	31	97-036	Trigger
14	97-056	Valve Seat	32	97-037	Pin - Trigger
15	97-055	Valve Stem	33	91-109	Pressure Stem Cap
16	UH-842	O-ring	34	LFG-465	Air Pressure Stem
17	97-029	Housing - seal	35	98-016	Spacer
18	97-027	Seal - Lip	36	98-049	Maintenance Kit Not Shown

Troubleshooting

Problem	Cause	Remedy
<i>3rd Spray Pattern</i>	Air Cap Blocked	Clean Air Cap
	Nozzle Blocked	Clean Nozzle
	Damaged Fluid Needle	Replace Fluid Needle
<i>Blistering</i>	Moisture on Surface	Clean Surface
	Wrong Solvent	Check Solvent
	Coats Not Compatible	Check Compatibility
	Insufficient Dry Time	Longer Dry Time
	Surface Too Cold	Warm Surface
<i>Fish Eyes</i>	Air Contamination	Add Air Filtration
	Silicone Contamination	Clean Parts With Solvent
<i>Heavy Middle Pattern</i>	Not Enough Atomizing Air	Increase Atomization Air
	Needle/Nozzle Too Large	Re-select Atomization Set
	Air Cap Holes Blocked	Clean Air Cap
<i>Intermittent/Pulsating Spray</i>	Worn Packing	Replace Packing
	Cup Not Secure	Tighten Cup
	Packing Nut Too Loose	Tighten Packing Nut
	Nozzle Loose	Tighten Nozzle
	Out of Material	Add Material
<i>Insufficient Fluid Flow</i>	Blocked Filter	Clean/Replace Filter
	Needle/Nozzle Too Small	Re-select Atomizing Set
	Blocked Fluid Nozzle	Clean Nozzle
	Loss of Air Pressure	Check Air Source/Hose
	Blocked Air Passage	Clean Passage With Brush
<i>Coarse/Lumpy Surface</i>	Cup Breather Hole Blocked	Clear Breather Hole
	Dirt or Dust on Surface	Tack Wipe Surface
<i>Mottled Surface</i>	Material is Contaminated	Strain/Replace Material
	Coating Too Thin	Use Less Thinner
<i>Orange Peel</i>	Coats Too Wet	Reduce Fluid Flow
	Improper Spray Technique	Hold Gun Parallel To Work
	Paint Drying Too Fast	Check Solvent Type
<i>Excessive Overspray</i>	Gun Too Far From Target	6 - 8 Inches is Ideal
	Too Much Atomizing Air	Reduce Atomizing Air
<i>Pin Holing</i>	Viscosity Too Heavy	Reduce Material
	Trapped Solvent	Apply Lighter Coats
	Improper Solvent	Check Coating Requirements
<i>Paint Leak</i>	System Contaminated	Clean All Parts
	Needle Size/Needle Damaged	Re-select Atomizing Set
	Loose Nozzle/Packing Nut	Tighten Nozzle/Packing Nut
<i>Runs/Sags</i>	Needle Not Closing	Replace Valve Spring
	Material Too Thin	Add Material
	Passes Too Slow	Speed up at 6" - 8" Distance
	Surface Too Cold	Warm Up Surface
	Too Much Product	Reduce Fluid Flow

APPENDIX "E"
(COATING PRODUCT DATA SHEET)



POLANE® HS Plus Polyurethane Enamel

Black F63B60
 Orange F63E61
 Green F63G62
 Blue F63L63
 Hi Hide Organic Red F63R62

Red Oxide F63R64
 Magenta F63R65
 Brite Red F63R66
 Silver F63S65
 Clear F63V67

White F63W66
 Hi Hide Opaque Yellow GS . F63Y63
 Hi Hide Organic Yellow RS . F63Y65
 Yellow Oxide F63Y68
 Catalyst V66V55

DESCRIPTION

POLANE® HS Plus Polyurethane Enamel is a two component coating providing high gloss, excellent exterior durability and resistance properties along with high volume solids and 2.8 VOC compliance. The single pigment colors are designed for intermixing to achieve great versatility in color matching capability.

Advantages:

- Under 2.8 VOC with Polane HS Plus Catalyst V66V55
- Excellent exterior color and gloss retention with V66V55 catalyst
- Excellent exterior physical and chemical performance properties
- Excellent appearance over many types of metal and plastic substrates
- Ideal coating for machine tool industry with resistance to most lubricants and cutting oils
- High solids - high spreading rate
- Air dry or force dry curing
- Full range of colors may be custom blended
- Excellent hardness and impact resistance
- Excellent mar and abrasion resistance
- Apply by conventional, airless, air assisted airless, HVLP or electrostatic spray
- Much faster drying times achieved with the use of infratherm type ovens
- For interior use, Polane HS Plus may be catalyzed 2:1 with Polane Plus Catalyst V66V44 and reduced 24% MAK
- Free of lead and chromate hazards

CHARACTERISTICS

Gloss: Full, 90+ units
 Volume Solids: 59 ± 2%
 catalyzed and reduced, may vary by color
 Viscosity: catalyzed and reduced
 18-27 seconds #3 Zahn Cup
 Recommended film thickness: *16-18*
 Mils Wet: 2.0 - 2.5 Mils Dry: 1.25 - 1.5
 Spreading Rate (no application loss)
 @ 1 mil dft: 940-960 sq ft/gal
 Air Drying (1.5 mils dft, 77°F, 50% RH):
 To Touch: 1-1½ hours
 To Handle: 10-12 hours
 Tack Free: 8 hours
 To Recoat: 5-6 hours
 Force Dry: 30-60 min. at 140-180°F
 Curing temperature must not exceed the heat distortion temperature of the plastic substrate.
 Infratherm oven schedule to tack free:
 (Flash off: 1 minute)
 1.5 lb Gas: 3 min., 2.5 lb Gas: 7 min.
 Mixing Ratio:
 3 part Polane HS Plus
 1 part Catalyst V66V55
 0.48 part (12%) MAK R6K30
 Pot Life: 3 hours
 Accelerated Drying:
 Add up to 1 ounce of Polane Accelerator, V66VB11 per gallon of Polane HS Plus.
 To Touch: 30-60 minutes
 To Handle: 2-3 hours
 Tack Free: 1-2 hours
 To Recoat: 1-1½ hours
 Force Dry: 30 min. at 140-180°F
 Mixing Ratio:
 3 part Polane HS Plus including Accelerator
 1 part Catalyst V66V55
 0.48 part (12%) MAK R6K30
 Pot Life: 1 hour
 Flash Point: 95°F Seta Flash Closed Cup
 Package Life: 2 years, unopened
 Air Quality Data:
 Non-photochemically reactive
 Volatile Organic Compounds (VOC)
 as packaged, maximum
 2.8 lb/gal, 336 g/L
 catalyzed and reduced as above, maximum
 2.8 lb/gal, 336 g/L
 An Air Quality Data Sheet is available from your local Sherwin-Williams facility.

SPECIFICATIONS

General: Substrate should be free of grease, oil, dirt, fingerprints, drawing compounds, any contamination, and surface passivation treatments to ensure optimum adhesion and coating performance properties. Consult Metal Preparation Brochure CC-T1 for additional details.

Aluminum, untreated: Prime with Industrial Wash Primer, P60G2, or Kem Aqua Wash Primer, E61G520, followed by Polane Plus Sealer, E65A71 or 2.8 VOC Catalyzed Epoxy Primer, E61A280.

Galvanized Steel, untreated: Prime with Industrial Wash Primer, P60G2, or Kem Aqua Wash Primer, E61G520, followed by Polane Plus Sealer, E65A71 or 2.8 VOC Catalyzed Epoxy Primer, E61A280.

Plastic: Due to the diverse nature of plastic substrates, a coating or coating system must be tested for acceptable adhesion to the substrate prior to use in production. Reground and recycled plastics along with various fire retardants, flowing agents, mold release agents, and foaming/blowing agents will affect coating adhesion. A filler or primer/barrier coat may be required. Please consult your Sherwin-Williams Chemical Coatings Sales Representative for system recommendations.

Steel or Iron: Remove rust, mill scale, and oxidation products. For best results, treat the surface with a proprietary surface chemical treatment of zinc or iron phosphate to improve corrosion protection. For untreated metal: Prime with Industrial Wash Primer, P60G2, or Kem Aqua Wash Primer, E61G520, followed by Polane Plus Sealer, E65A71 or 2.8 VOC Catalyzed Epoxy Primer, E61A280. For best corrosion resistance, prime treated steel with Polane Plus Sealer, E65A71 or 2.8 VOC Catalyzed Epoxy Primer, E61A280.

Wood (interior only): Must be clean, dry, and finish sanded. Seal with a full coat of Polane 2.8 Plus SprayFil, D61H75.

Testing: Due to the wide variety of substrates, surface preparation methods, application methods, and environments, the customer should test the complete system for adhesion and compatibility prior to full scale application.

APPLICATION

Typical Setups

Note: Maximum total reduction is 12% by volume to maintain 2.8 VOC.

Conventional Spray:

Air Pressure 40-50 psi
Fluid Pressure 5-10 psi
Cap/Tip047

Airless Spray:

Pressure 2000-2800 psi
Tip009 - .011"

Air Assisted Airless:

Air Pressure 10-30 psi
Fluid Pressure 600-900 psi
Cap/Tip009 - .011"

Electrostatic Spray:

Conductivity is 0.2-0.8 megohms resistance, which is suitable for all hand-held electrostatic spray setups.

HVLP:

Air Pressure 3-5 psi
Fluid Pressure 5-10 psi
Cap/Tip040

Dipping, brushing or flowcoat application is not recommended.

Cleanup:

Clean tools/equipment immediately after use with Polane Reducer, MEK, MIBK, or MAK.

Follow manufacturer's safety recommendations when using any solvent.

Performance Tests

Bonderite 1000 steel panels, F63W66 catalyzed and reduced, 1.5 mils dft, 30 minutes at 180°F, 14 days air cured

Salt Spray Test 300 hours
1/8" rust creepage at scribe
Humidity 100°F, 100% RH 300 hours
Impact Resistance, Direct 80 in lb
Impact Resistance, Reverse 80 in lb
Pencil Hardness H
Taber Abrasion
CS 17 wheel, 1000 g, 1000 cycles <100 mg
Water Immersion 24 hours
Adhesion, Crosshatch Excellent
MEK, 100 double rubs slight burnish
Heat Resistance, Dry 250°F

Chemical Resistance

Lubricating & Cutting Oils Excellent
Hydraulic Fluids Excellent

SPECIFICATIONS

Product Limitations:

- Polane HS Plus coatings must be catalyzed with V66V55 for exterior application. Do not vary catalyst ratio. Maintain an exact ratio. The catalyst ratio has been established for optimum hardness, flexibility, gloss, chemical and solvent resistance.
- For low gloss exterior applications, use Polane S Plus coatings rather than lowering gloss of Polane HS Plus.
- Do not blend with polyurethane other than Polane HS Plus and S Plus for exterior applications. No other catalysts, colorants, flattening bases or reducers are recommended because foreign materials such as alcohols and glycols destroy performance properties. Lacquers thinners and alcohol containing solvent blends should not be used with Polane enamels.
- Organic colors have limited hiding by themselves and must be blended with other chromatics for use.
- Polane HS Plus coatings are not recommended for exterior use on wood.
- Do not spray hot. Heat shortens pot-life. Do not pump catalyzed materials from drums into circulating system. Friction heat developed by pumps and circulation will shorten potlife.
- Protect Polane Enamels, Catalyst and Reducer from moisture as water affects potlife and properties. Store indoors.
- Do not package Polane coated products in airtight plastic bags unless completely cured. Since Polane Enamels continue to cure for several weeks, the buildup of organic solvents and reaction by-products could cause improper cure and adhesion failure in use.
- Do not exceed 1.5 mil dry film with airless or air assisted airless equipment due to sagging tendencies.
- Silver F63S65 does not offer the same color and gloss retention as other colors because of the weathering effect of aluminum pigment. Do not use for applications requiring long term color and gloss retention.
- For SILVER ONLY, use MEK as a reducer rather than MAK. The faster evaporation helps the metallic pigment orientation.
- The Clear F63V67 is intended for custom color intermixing and should not be used as a clearcoat because of its potential for yellowing.
- When using the VIC™ process, coatings must be packaged in phenolic lined containers to prevent discoloration.

CAUTIONS

Thoroughly review product label for safety and cautions prior to using this product. A Material Safety Data Sheet is available from your local Sherwin-Williams facility. Please direct any questions or comments to your local Sherwin-Williams facility.

LABEL CAUTIONS

Contents are FLAMMABLE. Vapors may cause flash fires. Keep away from heat, sparks, and open flame. During use and until all vapors are gone: Keep area ventilated - Do not smoke - Extinguish all flames, pilot lights, and heaters - Turn off stoves, electric tools and appliances, and any other sources of ignition. SEE CONTENTS STATEMENT ON LABEL.

VAPOR HARMFUL. Use only with adequate ventilation. This product must be used with an appropriate catalyst. Follow the respirator requirement and instructions on the catalyst.

Avoid contact with eyes and skin. Wash hands after using. Keep container closed when not in use. Do not transfer contents to other containers for storage. FIRST AID: If INHALED: If affected, remove from exposure. Restore breathing, Keep warm and quiet.

If on SKIN: Wash affected area thoroughly with soap and water. Remove contaminated clothing. Launder before re-use. If in EYES: Flush eyes with large amounts of water for 15 minutes. Get medical attention. If SWALLOWED: Get medical attention immediately.

SPILL AND WASTE: Remove all sources of ignition. Ventilate and remove with inert absorbent. Incinerate in approved facility. Do not incinerate closed container. Dispose of in accordance with Federal, State, and Local regulation regarding pollution.

DELAYED EFFECTS FROM LONG TERM OVER-EXPOSURE. Contains solvents which can cause permanent brain and nervous system damage. Intentional misuse by deliberately concentrating and inhaling the contents can be harmful or fatal.

This product must be mixed with other components before use. Before opening the packages, READ AND FOLLOW WARNING LABELS ON ALL COMPONENTS.

WARNING: This product contains chemicals known to the State of California to cause cancer and birth defects or other reproductive harm.

DO NOT TAKE INTERNALLY. KEEP OUT OF THE REACH OF CHILDREN. FOR INDUSTRIAL USE ONLY. SEE MATERIAL SAFETY DATA SHEET. K03213 11/98

Catalyst CONTAINS ISOCYANATES. People who have chronic (long-term) lung or breathing problems or have had a reaction to isocyanates, must not be in the area where this product is being applied. Where overspray is present, a positive pressure air-supplied respirator should be worn. If unavailable, a properly fitted organic vapor/particulate respirator may be effective. Consult catalyst MSDS and product label for complete handling instructions.

Note: Product Data Sheets are periodically updated to reflect new information relating to the product. It is important that the customer obtain the most recent Product Data Sheet for the product being used. The information, rating, and opinions stated here pertain to the material currently offered and represent the results of tests believed to be reliable. However, due to variations in customer handling and methods of application which are not known or under our control, The Sherwin-Williams Company cannot make any warranties as to the end result.

APPENDIX "F"
(ASTM STANDARDS)

- ASTM D 823 - 92a Standard Practices for Producing Films of Uniform Thickness of Paint, Varnish, and Related Products on Test Panels.
- ASTM D 609 - 95 Standard Practices for Preparation of Cold-Rolled Steel Panels for Testing Paint, Varnish, Conversion Coatings, and Related Coating Products.
- ASTM D 1200 - 94 Standard Test Method for Viscosity by Ford Viscosity Cup
- ASTM D 1400 - 94 Standard Test Method for Nondestructive Measurement of Dry Film Thickness of Nonconductive Coatings Applied to a Nonferrous Metal Base.
- ASTM D 1475 -96 Standard Test Method for Density of Liquid Coatings, Inks, and Related Products.
- ASTM D 1730 -96 Practices for Preparation of Aluminum and Aluminum-Alloy Surfaces for Painting.
- ASTM D 2369 - 98 Standard Test Method for Volatile Content of Coatings
- ASTM D 3925 - 91 Standard Test Method for Sampling Liquid Paints and Related Pigmented Coatings.
- ASTM D 3964 - 95 Practices for Selection of Coating Specimen for Appearance measurement
- ASTM D 5286 - 95 Standard Test Method for Determination of Transfer Efficiency Under General Production Conditions for Spray Application of Paint.

APPENDIX "G"
(MIL THICKNESS TEMPLATE)

Solid Part

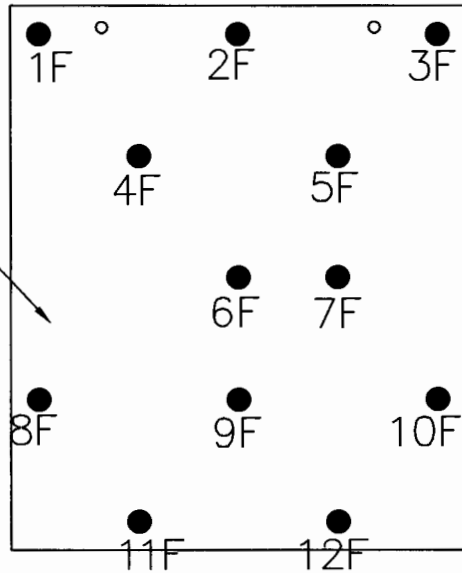

Window Part

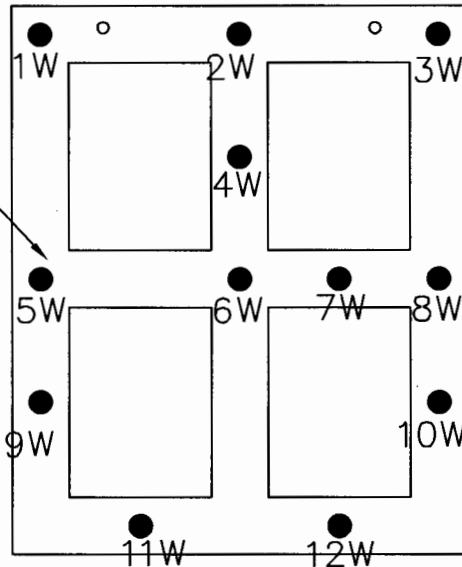

Specifications:

- Aluminum
- Thickness: 0.158 cm (0.0625 in)

Note: the panes have been divided by axis to indicate the locations of the mil thickness measurement points. All the values are in inches

UNIVERSITY OF NORTHERN IOWA
 IOWA WASTE REDUCTION CENTER
 1005 TECHNOLOGY PARKWAY
 CEDAR FALLS, IOWA 50614-6951.
 (319) 273-8905 FAX 268-3733

Laser Touch Research #003
 Test Part Templates
 with Measurement Locations (Film Thickness)
 REVISED SCALE 1/2" = 1'0"
 DRAWING NUMBER Restem.dwg 3 OF 4

TE 24/08/99 DRAWN Omar Blanco CHECKED RK SURVEY

APPENDIX "H"
(SPECULAR GLOSS TEMPLATE)

Solid Part

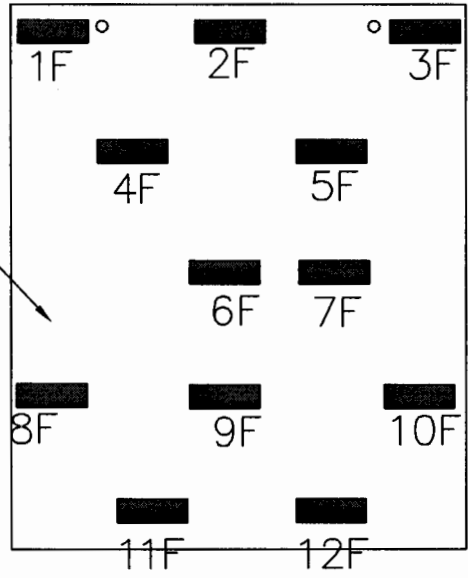

Window Part

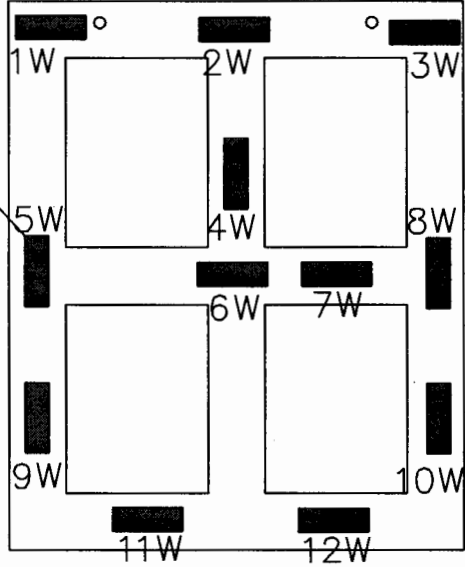

Specifications:

- Aluminum
- Thickness: 0.158 cm (0.0625 in)

UNIVERSITY OF NORTHERN IOWA				Laser Touch Research		#004
IOWA WASTE REDUCTION CENTER 1005 TECHNOLOGY PARKWAY CEDAR FALLS, IOWA 50614-6951 (319) 273-8905 FAX 268-3733				Test Part Templates with Measurement Locations (Specular Gloss)		
DATE	DRAWN	CHECKED	SURVEY	REVISED	SCALE	
24/08/99	Omar Blanco	RK			1/2" = 1'0"	
				DRAWING NUMBER	Restem.dwg	4 of 4

APPENDIX "I"

(SPRAY TECHNICIANS INSTRUCTIONS FOR THE LASER TOUCH™)

Spray Technician Instructions for the Laser Touch™ Model LT-02 TQAPP.

A.- Laser Touch™ Research Questionnaire

1. Laser Touch™ instructor

Assist the Spray Technician with the Laser Touch™ Research Questionnaire. _____
(See Attachment “A”)

2. **Spray Technician**

Complete Laser Touch™ Research Questionnaire

Spray technician states they ready to go on. _____

B. Spray Technician “Spray gun set-up” Session

1. Laser Touch™ instructor

- Adjust the wall air pressure regulator to 100 psi. _____
- Adjust the spray gun air pressure regulator to 38 psi, _____
- with the spray gun triggered. _____
- Record pressure of the test cap air pressure. _____
- Remove test cap air pressure gauge and install the # 7 air cap. _____
- Fill the spray gun with paint. _____
- Open the fan pattern 2 turns. _____
- Open the fluid control adjustment 3 turns. _____
- Shoot the test patterns on the spray pattern test paper. _____
- If the spray pattern is acceptable allow spray technician _____
to practice spray patterns on spray pattern test paper.
If the spray pattern is not acceptable correct the spray gun _____
problems. _____

Read the following verbiage:

You are allowed to adjust the fluid and/or lower the air pressure of the spray gun to fit your spray application speed during the practice session, however do not make any adjustments to the spray gun after the practice session.
Do you have any questions? _____

C. Spray Technician “Warm-up” Practice Session

1. Laser Touch™ instructor:

(Index - practice parts into start-up position) _____

Read the following verbiage:

Practice making spray passes along the entire length of the practice part to become comfortable with the spray gun and the way the paint is “laying down.” The coating you will be spraying is a Sherwin Williams high solids product called Polane. The coating has a high spreading rate with a recommend wet film build of 2.0 -2.5 mils. When you feel comfortable and confident with the way the paint is laying down tell the instructor you are ready to move to the next step. The instructor will check the wet mil thickness and advise you of your application film thickness. Please keep in mind that we are looking for a quality finish and that you are allowed to go back and touch-up lightly covered areas. It is important that your first pass have a sufficient amount of coating to properly cover the part. The spray gun manufacturer recommends a spray gun distance of 6 to 8 inches from the part. Do you have any questions? _____

2. Spray Technician

Practice operating the spray gun and become comfortable with the spray gun and the way the paint is “laying down.”

Spray technician states they ready to go on. _____

3. Laser Touch™ instructor:

(Fill the spray gun with paint). _____

Index the “F” solid practice part into position. Continue to index the practice parts as signaled by the spray technician. Allow the spray technician to practice spraying the two Solid parts and the two “W” cutout shaped part. _____

Read the following verbiage:

Practice making spray passes along the entire length of the practice parts. Become comfortable with the spray gun and the way the paint is “laying down” on the practice parts. When you are done practicing on each part signal the staff to index another practice part. When you feel comfortable and confident with the way the paint is laying down tell the instructor you are ready to move to the next step. _____

- Move the solid part into position. _____

Solid Parts:

Read the following verbiage:

Begin spraying the solid parts. Start spraying at the upper left or right hand corner working your way down across the part. We suggest using a 50 % overlap technique to achieve adequate coverage. Spray the parts to the best of your ability being conscious of the Transfer Efficiency and finish quality. **Please do not change the spray gun settings after you have completed the spray gun set up during the practice session.** _____

4. Spray Technician

Practice spraying the solid parts to become comfortable with the spray gun and the way the paint is “laying down.”

Spray technician states they ready to go on. _____

5. Laser Touch™ instructor:

Check the wet mils and advise the painter of the wet mil thickness. _____

- Move the W cutout shaped practice part into position.

W Cutout Shaped Parts:

Read the following verbiage:

Begin spraying the part, follow the same general pattern as you did on the solid part. On the cutout parts start spraying at the upper left or right hand corner and spray the parts passes working your way down across the panel. Spray the parts to the best of your ability remaining conscious of the Transfer Efficiency and finish quality. _____

6. Spray Technician

Practice spraying the W framed shaped part to become comfortable with the spray gun and the way the paint is “laying down.”

Spray technician states he/she is ready to go on. _____

D. Instructions for the Spray Technician Pre-Test:

1. Laser Touch™ instructor:

Refill the spray gun that was used for the “warm up” practice session with paint, to approximately 2000 ± 100 grams of paint for each part. Before handing the spray gun to the spray technician, weigh the spray gun and record the weight. Weigh the spray gun after the spray technician has completed spraying each part and record the weight on the pre-test data form.

Repeat the above procedure for each test part. _____

Solid Parts:

Read the following verbiage:

Begin spraying the parts, follow the same general pattern as you did in the practice session. On the solid parts start spraying at the upper left hand corner. We suggest using the 50 % overlap technique while working your way down across the panel. After spraying each part, stop and hand the spray gun to the instructor to be re-weighed. Do not trigger the spray gun just to see if it is working before spraying. Spray the parts to the best of your ability being conscious of the Transfer Efficiency and finish quality. Be sure to hand the spray gun to the instructor after each part, so that the spray gun can be weighed.

Do you have any questions? _____

W Cutout Shaped Parts:

Read the following verbiage:

Begin spraying the parts, following the same general pattern used in the practice session. On the cutout shaped parts start spraying at the upper left hand corner and spray the parts working your way down across the panel. After spraying each part stop and hand the spray gun to the instructor to be re-weighed. Do not trigger the spray gun just to see if it is working before spraying. Spray the parts to the best of your ability remembering the Transfer Efficiency and finish quality. Be sure to hand the spray gun to the instructor after each part, so that the spray gun can be weighed. _____

E. Instructions for using the Laser Touch™ targeting tool:

1. Laser Touch™ instructor:

Show the Laser Touch™ promotional video _____

2. Laser Touch™ instructor:

Read the following verbiage:

The Laser Touch targeting tool is turned on and off by depressing a switch on the outside of the housing. The switch includes a green LED that is lit whenever the switch is ON. Pressing the switch again turns the unit OFF. The laser beams are turned off and the green LED is no longer lit. _____

- The following six steps are done **without** any spray painting being done:

3. Spray Technician

Turn on the Laser Touch™ by depressing the on - off button. _____

F. Distance Exercises

1. Laser Touch™ instructor:

Read the following verbiage:

Two laser beams are projected from the unit. At the correct distance, the laser beams will converge at a distance of (6) inches from the target. Practice moving the spray gun and Laser Touch™ closer to and back away from the marking board to become comfortable with having the laser dots come together. When you feel comfortable and confident with aligning the laser beams tell the instructor you are ready to move to the next step. _____

2. Spray Technician

Practice moving the spray gun and the Laser Touch™ about and become comfortable with bringing the laser dots together.

Spray technician states he/she is ready to go on. _____

3. **Laser Touch™ instructor:**

Read the following verbiage:

Practice making spray passes along the entire length of the blue line on the marking board with the laser beams converged. When you feel comfortable and confident with keeping the laser beams converged as you make a spray pass, tell the instructor you are ready to move to the next step. _____

4. **Spray Technician**

Practice making spray passes along the entire length of the blue line with the laser beams converged.

Spray technician states he/she is ready to go on. _____

G. Distance and Targeting Exercises

1. **Laser Touch™ instructor:**

Read the following verbiage:

Practice making spray passes along the entire length of the lines on the marking board with the laser beams converged and aimed on the blue line. Practice at least 5 passes. When you feel comfortable and confident with keeping the laser beams converged as you make a spray pass tell the instructor you are ready to move to the next step. _____

2. **Spray Technician**

Practice making spray passes along the total length of the blue line with the laser beams converged, and aimed at the blue line.

Spray technician states he/she is ready to go on. _____

3. **Laser Touch™ instructor:**

Uncover the remaining blue lines on the marking board. Introduce the Laser Touch Training Gun with the Laser Touch attached.

Read the following verbiage:

The patented Laser Touch Training Gun is designed to assist coatings instructors, process engineers, system setup technicians, professional trainers, and community college instructors to demonstrate proper spray technique and/or spray system methodology. The gun projects a laser spray pattern image which changes in size and intensity based on the gun's orientation and distance to the target. The spray pattern image is designed to demonstrate proper spray gun distance, spray angle, lead and lag, banding/edging, spray pattern orientation, overlap, and plan of attack on a target surface. In other words, how to put as much of the paint on the part as possible. The Laser Touch targeting system may also be mounted to the Laser Touch Training Gun to provide the spray Technician with instantaneous visual feedback for determining accurate distance control and overlap. When used together the Laser Touch Training Gun and the Laser Touch combination gives the spray technician the advantage of using the latest innovation in spray application training.

The line # 2 indicates the wet edge of the first pass. Aim and converge the Laser Touch's converged beams at the line # 1 then trigger the Laser Training Gun. When the Laser Training Gun is held parallel to the part, notice that the lower portion of the Laser Touch Training Gun spray pattern is aligned with the line # 2 which represents the wet edge of the first spray pass. Practice making spray passes along the full length of line # 1 with the laser beams converged and aimed at line # 1. Then start a second pass with the Laser Touch beams aimed and converged at line # 2 with the Laser Training Gun triggered. This will allow you to have perfect overlap and a uniform and consistent mil build. Practice spray passes moving from line #1 to line #2 working your way down the marking board, until you have finished line #5. When you feel comfortable and confident with keeping the laser beams converged and on target as you make a spray pass tell the instructor you are ready to move to the next step. _____

4. Spray Technician

Practice making spray passes along the entire length of the blue lines with the laser beams converged and aimed at the blue line.

Spray technician states he is ready to go on. _____

H. Distance, Targeting, and Spray Gun Orientation Exercises

1. Laser Touch™ instructor:

Draw two vertical lines at both ends of lines # 1 through # 5.
The drawing represents the “F” solid part. _____

Read the following verbiage:

Follow the preceding practice exercise with the following additional steps. Proper spray gun orientation reduces painter fatigue and gun movement, and allows the entire fan spray pattern to be used on the part. Move the converged beams off the edge of the drawn part about 1/4 of an inch. Start your spray pass with the Laser Touch Training gun triggered about a 1/4 of an inch from the edge of the drawn part, aimed at line # 1. Make a spray pass along line # 1. Stop triggering the spray gun 1/4 of an inch past the edge of the drawn part. Practice spray passes moving from line #1 to line #2 working your way down the marking board, until you have finished line #5. Make sure that you begin and end each pass a 1/4 of inch before and after the outside edge of the drawn part. Start and finish each spray pass in the same manner as before. This allows you to use the targeting features of the Laser Touch to properly orientate the spray pattern on the part.

Targeting the spray pattern reduces spray time, arm and wrist movement, and operator fatigue. Practice at least 5 passes. When you feel comfortable and confident with the centering exercise tell the instructor you are ready to move to the next step. _____

2. **Spray Technician**

Practice using the Laser Touch’s targeting feature to aim and/or center your spray pattern as you make your spray passes along the total length of the drawn part with the laser beams converged and aimed at the center of the part.

Spray technician states he/she is ready to go on. _____

3.- Laser Touch™ instructor:

Fill the spray gun that was used in the pre test with paint and install a Laser Touch targeting tool on the spray gun. _____

Read the following verbiage:

You will now repeat the practice exercises, on practice parts.

Practice making spray passes along the entire length of the practice part with the laser beams converged. You will need to focus less on the laser beams and more on the way the paint is “laying down.” Concentrate on the converged beams at the beginning, middle and end of each spray pass. Aim the converged beams at the **WET** edge of the first pass and begin spraying. Continue to aim at the **WET** edge of the preceding pass as you work your way down the panel. Continue making 50 % overlap practice passes along the total length of the practice part with the laser beams converged and aimed at the wet edge of the preceding pass. Then start a second pass with the converged Laser Touch’ beams aimed at the wet edge of the previous spray stroke or pass. This will allow you to have perfect overlap and a uniform and consistent mil build. Notice that when the spray gun is held parallel to the part and the laser beams are converged the coating is uniform and consistent. If the gun is not parallel to the part, the beams are not converged and the coating will be heavy on the top or bottom of each spray pass. When you feel comfortable and confident with using the Laser Touch and the way the paint is laying down tell the instructor you are ready to move to the next step. When you are done practicing on each part wait for another part to be indexed.
Do you have any questions? _____

4. Spray Technician

Practice making spray passes along the entire length of the practice part with the laser beams converged and watching the paint lay down.

Spray technician states he/she is ready to go on. _____

I. Instructions for the Spray Technician Post-Test:

1. Laser Touch™ instructor:

Install a Laser Touch targeting tool on the spray gun. Refill the spray gun that was used in the pre test with paint to approximately 2000 ± 100 grams of paint for each part.

Solid Parts:

Read the following verbiage:

Begin spraying the parts following the same pattern used in the pre-test. On the solid parts start spraying at the upper left or right hand corner and make 50 % overlap passes working your way down across the panel. After spraying each part stop and hand the spray gun to the instructor to be re-weighed. Do not trigger the spray gun just to see if it is working before spraying. Spray the parts to the best of your ability remembering Transfer Efficiency and finish quality. Be sure to hand the spray gun the instructor after each part, so that the spray gun can be weighed. Please keep in mind that we are looking for a quality finish and that you are allowed to go back and touch-up lightly covered areas. It is important that your first pass have a sufficient amount of coating to properly cover the part. _____

W Shaped Parts:

Read the following verbiage:

Begin spraying the parts, using the same pattern as you did in the pre-test. On the W shaped parts start spraying at the upper left hand corner and spray the parts by working your way down across the panel. After spraying each part stop and hand the spray gun to the instructor to be re-weighed. Do not trigger the spray gun just to see if it is working before spraying. Be sure to hand the spray gun to the instructor after each part, so that the spray gun can be weighed and recorded. Spray the parts to the best of your ability keeping in mind Transfer Efficiency and finish quality. _____

APPENDIX "J"
(LASER TOUCH™ RESEARCH QUESTIONNAIRE)

Laser Touch™ Research Questionnaire.-

A.- Demographic Data

-Name: _____

-Company: _____

-Sex: Male Female

-Educational Level:

2. High-School Graduate Technical School University

Name of the school: _____

Location: _____

B.- Technical Data

-Years of experience as a spray technician: _____

-Have you ever received any paint and coating training: yes No

If yes, please describe: _____

-How often have you been receiving the training?

- | | |
|--|--|
| <input type="checkbox"/> Monthly | <input type="checkbox"/> Yearly |
| <input type="checkbox"/> Every three-month | <input type="checkbox"/> Every two years |
| <input type="checkbox"/> Every six-month | <input type="checkbox"/> More than two years |

-What type of spray gun have you use in the last year:

- | | |
|---------------------------------------|---|
| <input type="checkbox"/> Conventional | <input type="checkbox"/> HVLP-Electrostatic |
| <input type="checkbox"/> HVLP | <input type="checkbox"/> Electrostatic |
| <input type="checkbox"/> Airless | <input type="checkbox"/> Air-Assisted Airless |
| <input type="checkbox"/> Other: _____ | |

-What type of paint are you currently spraying:

- | | |
|---|---|
| <input type="checkbox"/> Conventional Solids Solventborne | <input type="checkbox"/> High Solids Solvertborne |
| <input type="checkbox"/> Waterborne Coatings | <input type="checkbox"/> Lacquer |
| <input type="checkbox"/> Automotive | <input type="checkbox"/> Other: _____ |

-What of the following parameters do you take into consideration at the time of spraying:

- | | |
|---|---|
| <input type="checkbox"/> Solid Content | <input type="checkbox"/> Viscosity |
| <input type="checkbox"/> Atomization | <input type="checkbox"/> Fluid Flow |
| <input type="checkbox"/> Paint Temperature | <input type="checkbox"/> Booth Temperature & Humidity |
| <input type="checkbox"/> Spraying Technique | <input type="checkbox"/> Part Shape |

APPENDIX "K"
(SPRAY TECHNICIAN RECORDED PATTERNS)

2ND - Window -> OTTR Method 1 ColdRM

Inlet Air Pressure	38	Spray Technician:	CALB
Wall Air Pressure:	90	Material:	SFw
Air Flow # Turns:	2 1/2	Viscosity-Ford Cup#4:	52 sec
Fluid Flow # Turns:	2 3/4	Temperature:	75
Spray Distance:	6	Wet Mill Thickness:	
Tip Size:	36	Dry Mill thickness:	
Needle Size:	36	Date:	10-21-99

Pre-Test

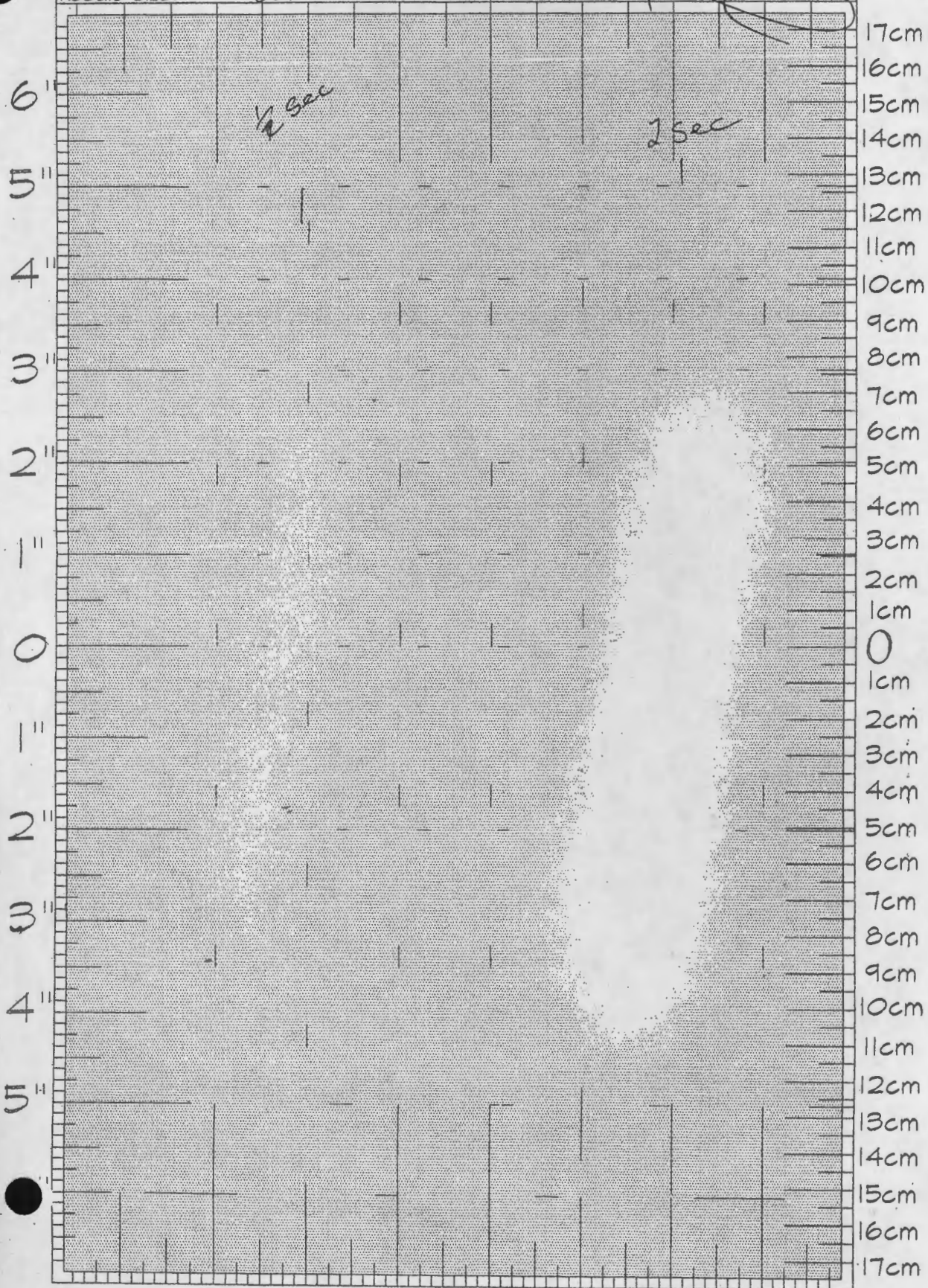

Inlet Air Pressure: 38	Spray Technician: <i>R. A. B.</i>
Wall Air Pressure: 90	Material: <i>Stw Pol. Am.</i>
Air Flow # Turns: $2\frac{3}{4}$	Viscosity-Ford Cup#4: <i>51 sec.</i>
Fluid Flow # Turns: $1\frac{1}{2}$	Temperature:
Spray Distance: 6"	Wet Mill Thickness:
Tip Size: $\#36$	Dry Mill thickness:
Needle Size: $\#36$	Date: _____ Post-Test: _____

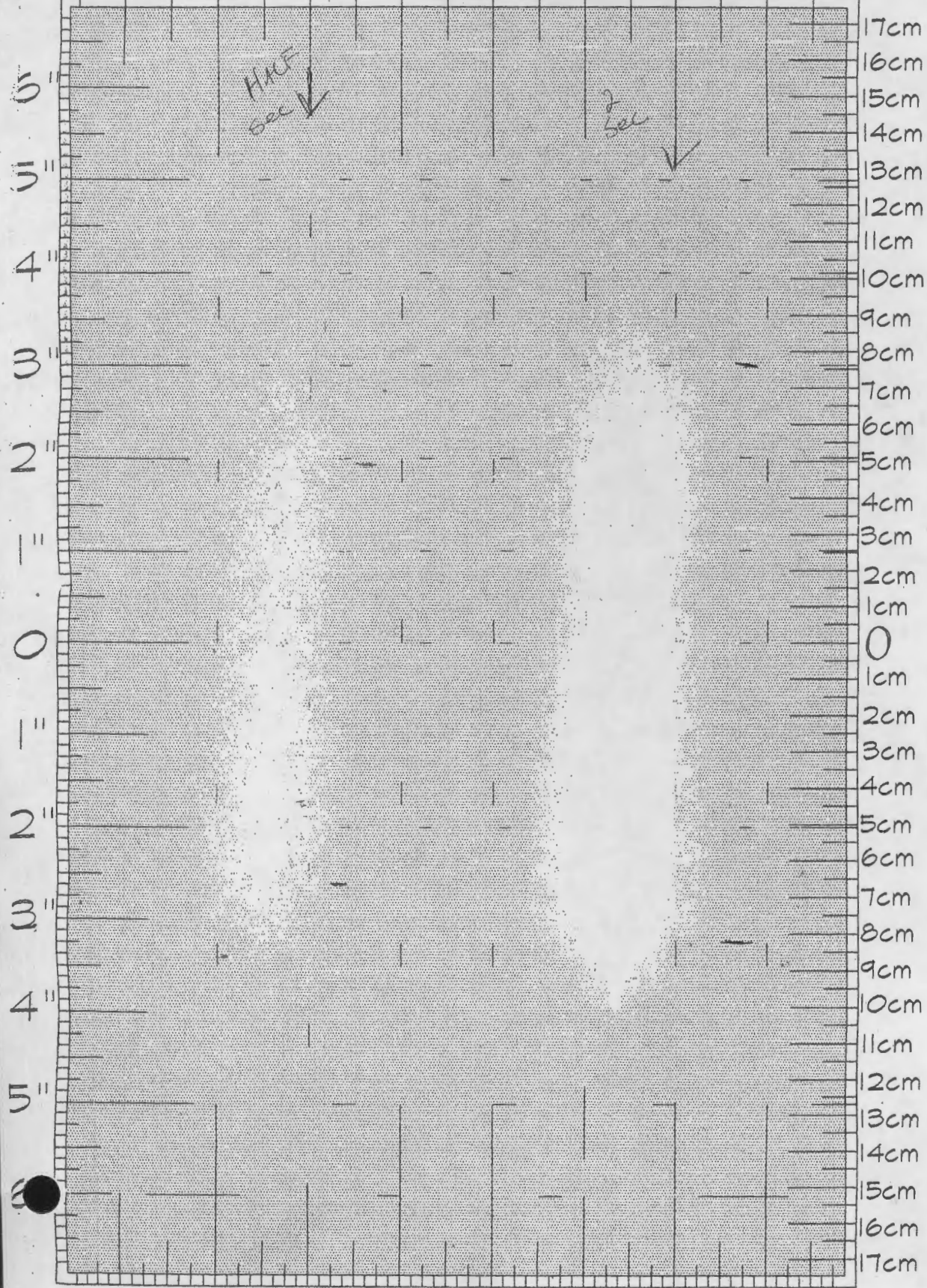

Inlet Air Pressure	38	Spray Technician:	Jeremy Kennedy
Wall Air Pressure:	90	Material:	Stw Polane
Air Flow # Turns:	2	Viscosity-Ford Cup#4:	56
Fluid Flow # Turns:	1 3/4	Temperature:	74
Spray Distance:	7 1/4	Wet Mill Thickness:	3
Tip Size:	36	Dry Mill thickness:	POST-TEST
Needle Size:	36	Date:	10-28-98

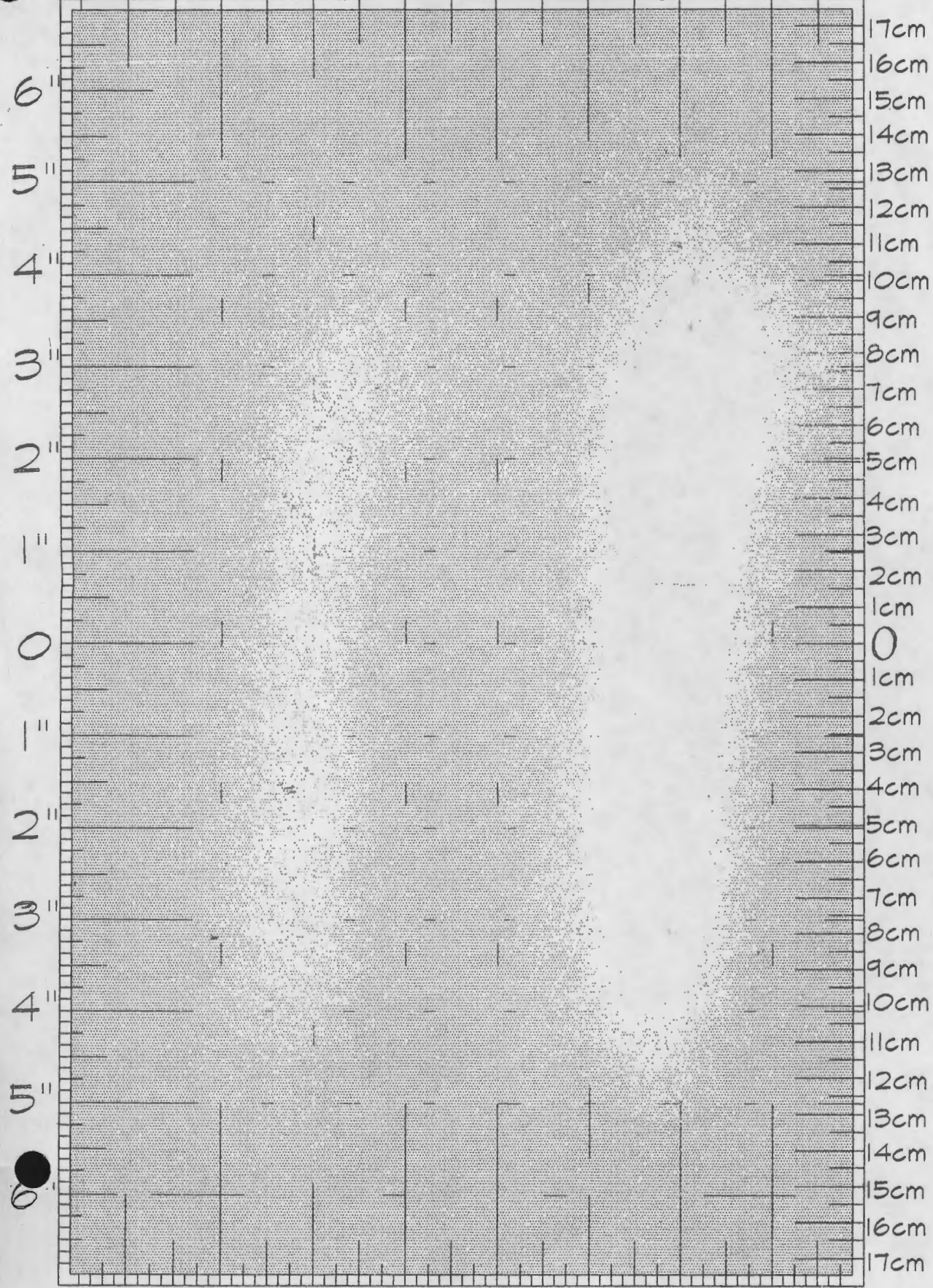

Inlet Air Pressure	38	Spray Technician: Jeremy Kennedy	
Wall Air Pressure:	90	Material: Sea Polane	
Air Flow # Turns:	1/8	Viscosity-Ford Cup#4:	57
Fluid Flow # Turns:	2 1/4	Temperature:	7.4
Spray Distance:	6"	Wet Mill Thickness:	1.5 - 2.0
Tip Size:	36	Dry Mill thickness:	PRE-TEST
Needle Size:	36	Date: 16-28-99	16-28-99

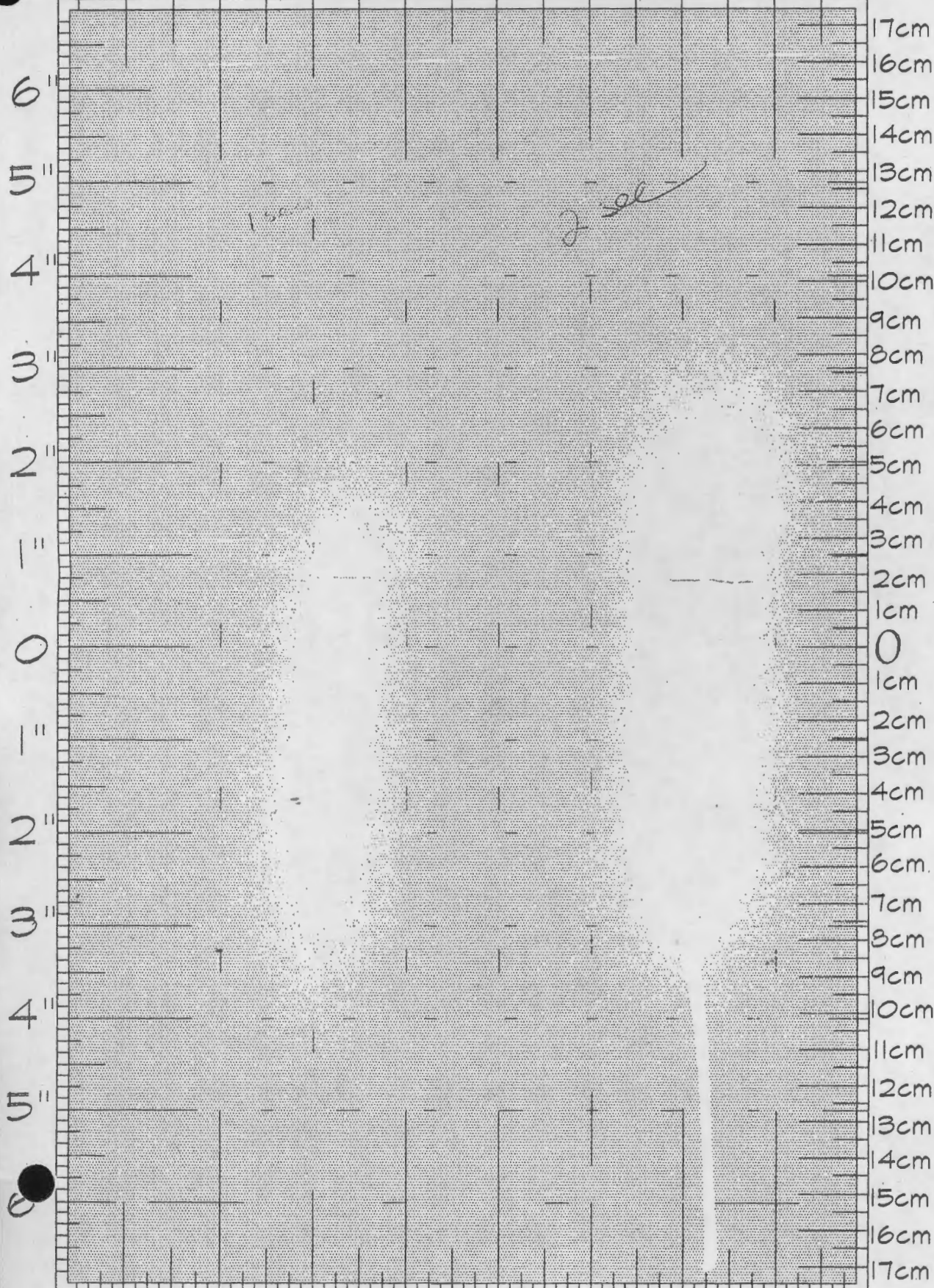

P051

Inlet Air Pressure: 30	Spray Technician: Judy FAUK Hessel	
Wall Air Pressure: 92	Material: Stw Pol	
Air Flow # Turns: 2 1/2	Viscosity-Ford Cup#4: 57	
Fluid Flow # Turns: 4	Temperature: 70	
Spray Distance: 7"	Wet Mill Thickness: 2-3	
Tip Size: 36	Dry Mill thickness:	
Needle Size: 30	Date: 11-2-99	Post-Test.

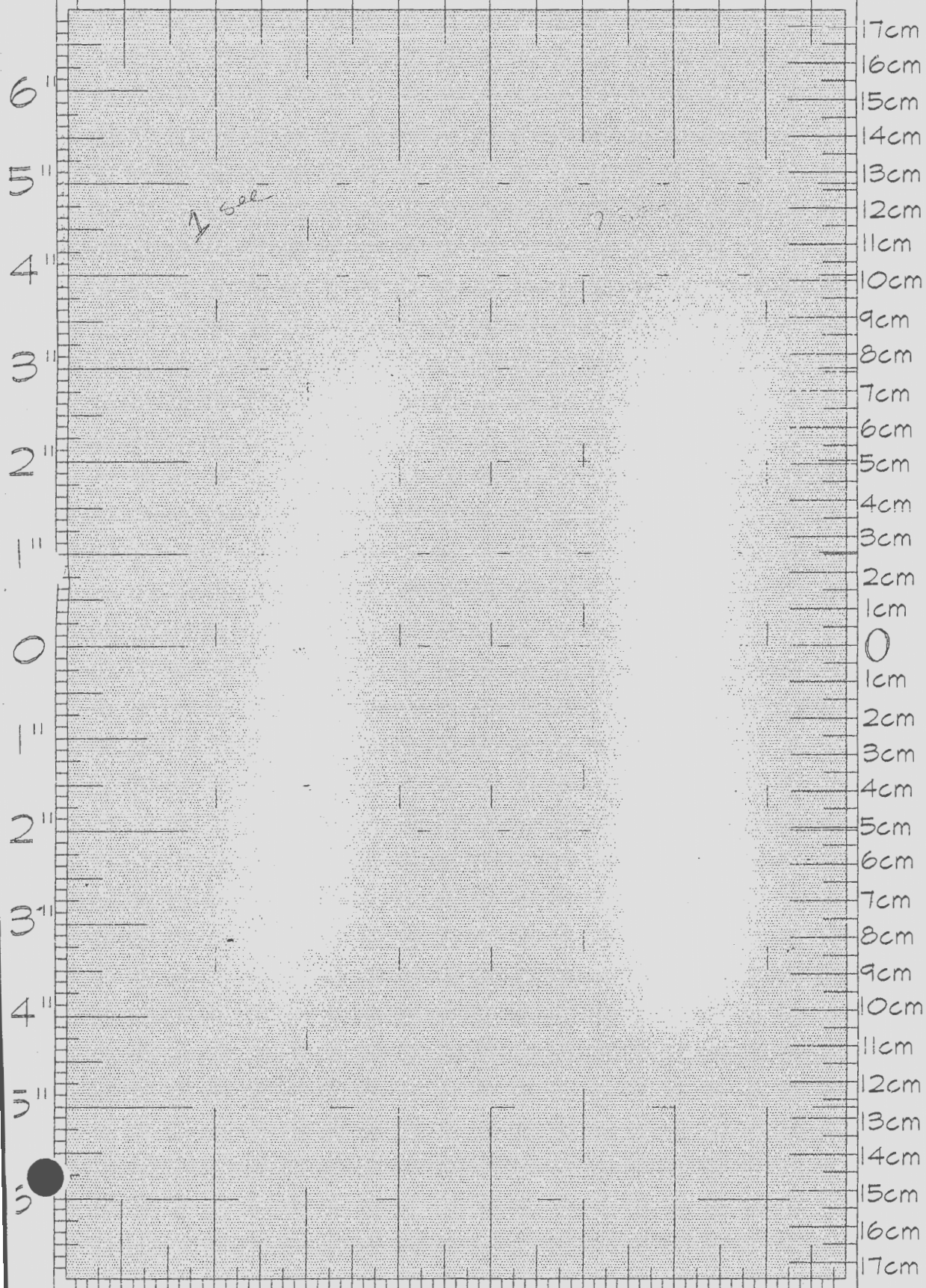

PKE

Inlet Air Pressure: 30	Spray Technician: Jody FARR HAUSER
Wall Air Pressure: 93	Material: St 6 Pd base
Air Flow # Turns: 2 1/4	Viscosity-Ford Cup#4: 54.5
Fluid Flow # Turns: 4	Temperature: 71.5
Spray Distance: 9.5	Wet Mill Thickness: 2.3 mil
Tip Size: 36	Dry Mill thickness:
Needle Size: 36	Date: 11-2-99

Pre-Test

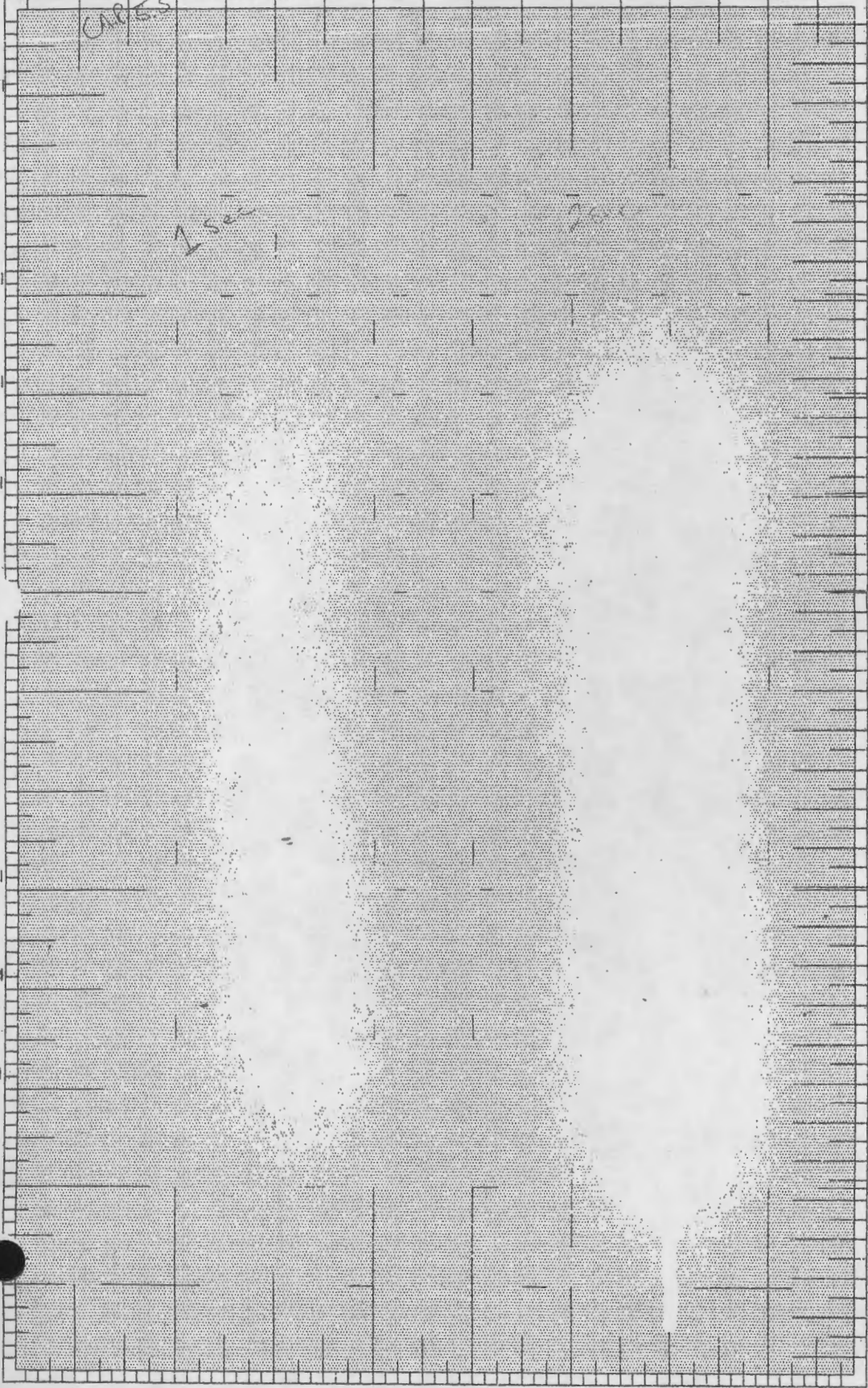

17cm
16cm
15cm
14cm
13cm
12cm
11cm
10cm
9cm
8cm
7cm
6cm
5cm
4cm
3cm
2cm
1cm
0
1cm
2cm
3cm
4cm
5cm
6cm
7cm
8cm
9cm
10cm
11cm
12cm
13cm
14cm
15cm
16cm
17cm

6"
5"
4"
3"
2"
1"
0
1"
2"
3"
4"
5"
6"
7"
8"
9"
10"
11"
12"
13"
14"
15"
16"
17"

CAP - 7.0 PSI Pre-Test

Inlet Air Pressure	38	Spray Technician:	Tim HERTWSTEIN
Wall Air Pressure:	92	Material:	Stw
Air Flow # Turns:	1 1/2	Viscosity-Ford Cup#4:	55.5
Fluid Flow # Turns:	3 1/2	Temperature:	74
Spray Distance:	7-8	Wet Mill Thickness:	2.5
Tip Size:	36	Dry Mill thickness:	
Needle Size:	36	Date:	11-4-99 Pre-Test

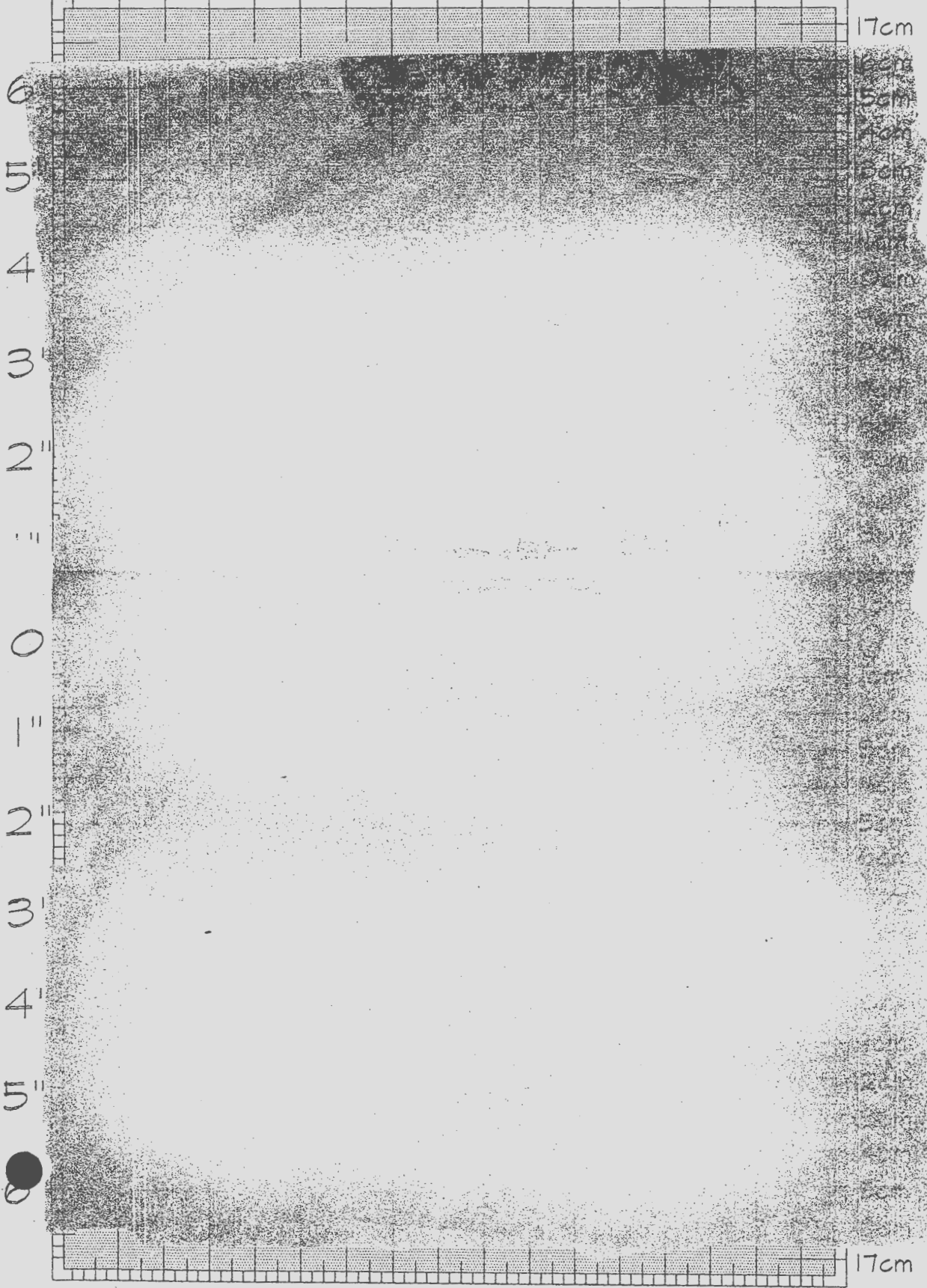

Air CAP 6.5

Inlet Air Pressure: 38	Spray Technician: Cuet Perkins
Wall Air Pressure: 93	Material: 54u
Air Flow # Turns: 1 3/8	Viscosity-Ford Cup#4:
Fluid Flow # Turns: 2 1/2	Temperature:
Spray Distance: 4 to 5.12	Wet Mill Thickness: 2 to 3rd Pass
Tip Size:	Dry Mill thickness:
Needle Size:	Date:
	Post-Test

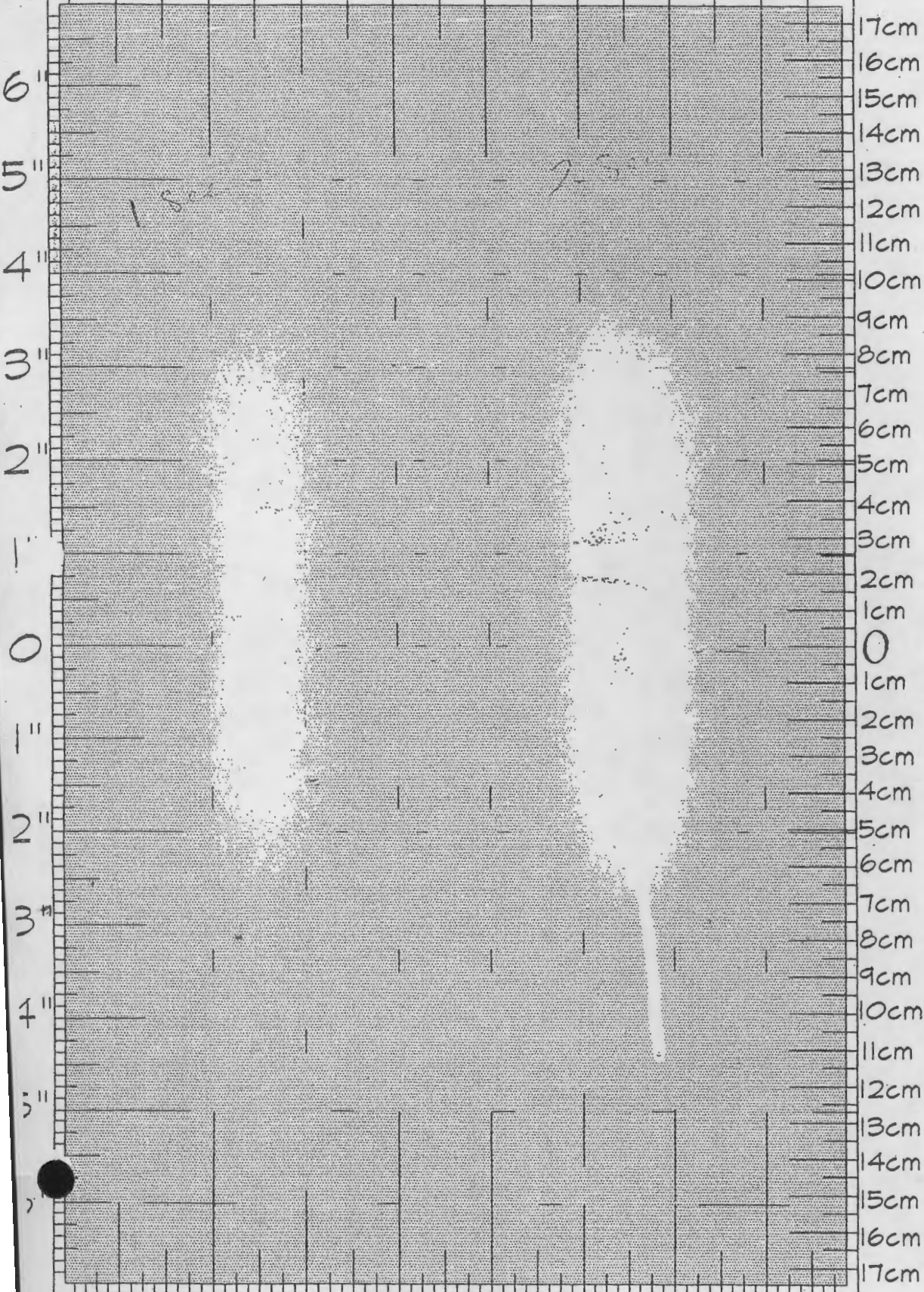

Air Cap 6.5

Inlet Air Pressure: 38	Spray Technician: Cuert Tomkins
Wall Air Pressure: 93	Material: SFW
Air Flow # Turns: 1 3/8	Viscosity-Ford Cup#4: 55
Fluid Flow # Turns: 2 1/2	Temperature: 52
Spray Distance: 6-8	Wet Mill Thickness: 2
Tip Size: 36	Dry Mill thickness:
Needle Size: 36	Date: 11-9-99

Pre-Test

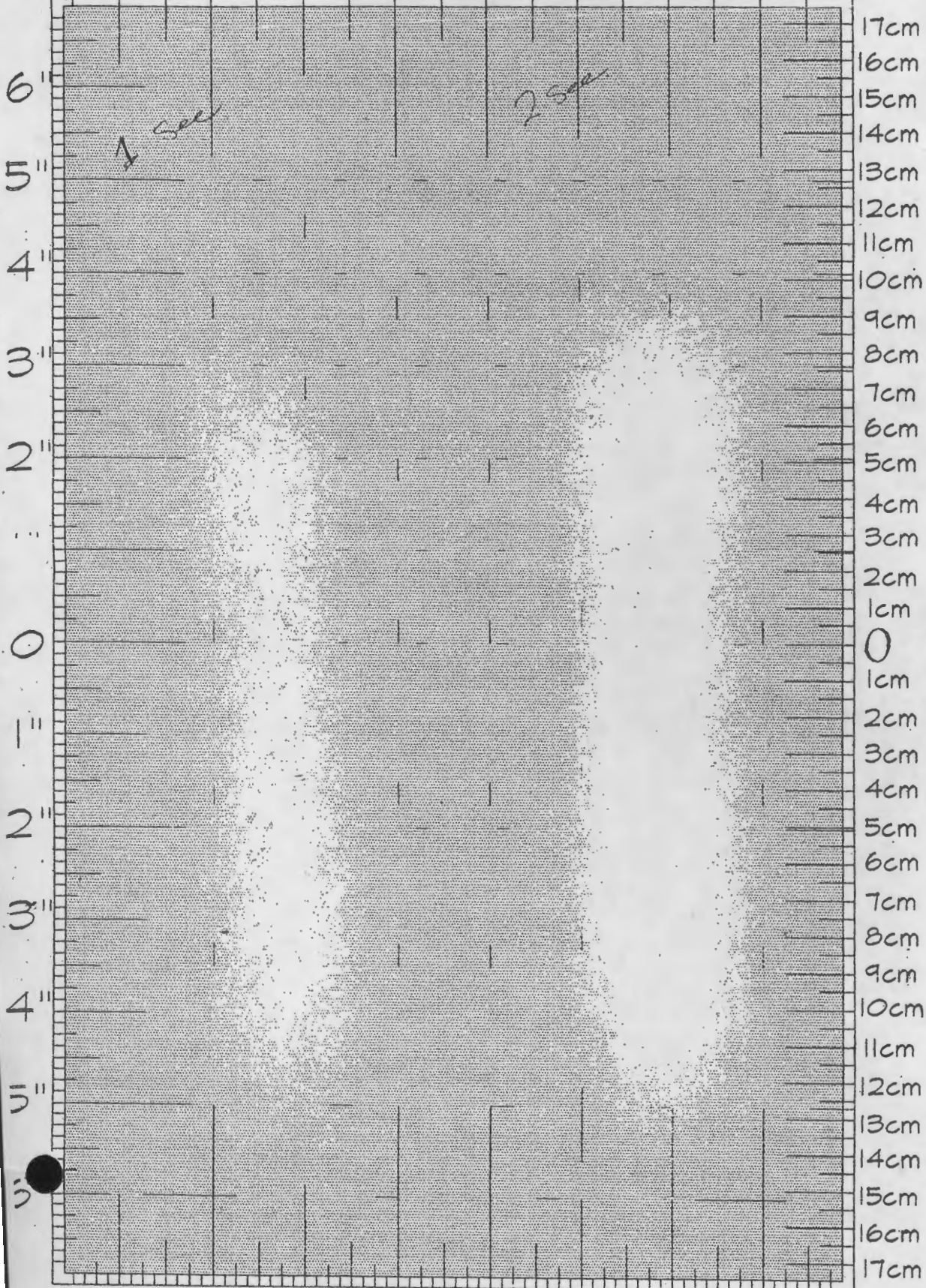

CAP 84

Inlet Air Pressure: 48	Spray Technician: LEHARD VONNER	
Wall Air Pressure: 94	Material:	
Air Flow # Turns:	Viscosity-Ford Cup#4:	
Fluid Flow # Turns:	Temperature:	
Spray Distance:	Wet Mill Thickness:	
Tip Size:	Dry Mill thickness:	
Needle Size:	Date:	Post-Test

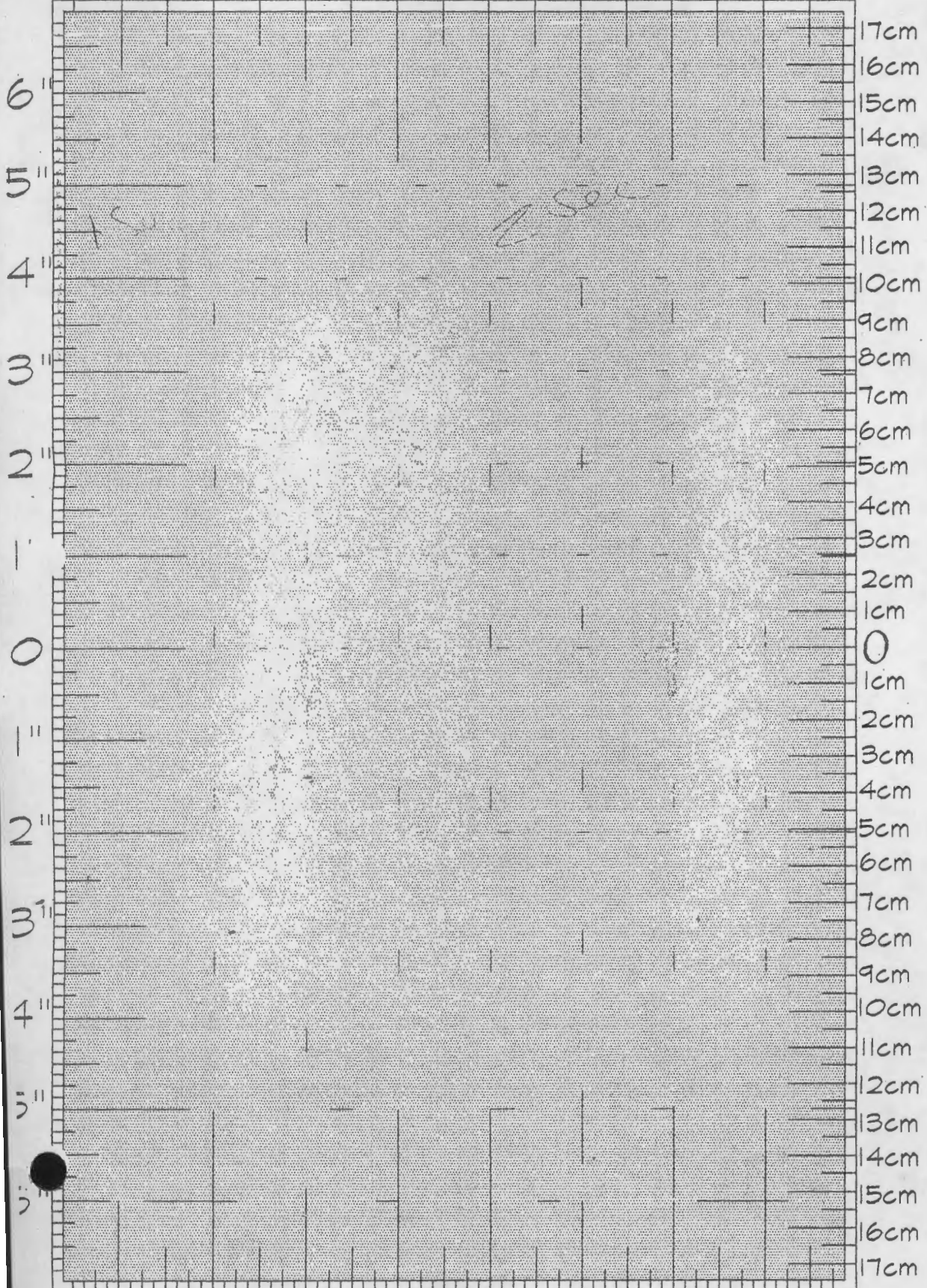

CA 8.7

Inlet Air Pressure: 48	Spray Technician: <i>Lenora Moore</i>
Wall Air Pressure: 95	Material: S+W
Air Flow # Turns: $\approx 5\frac{1}{2}$	Viscosity-Ford Cup#4:
Fluid Flow # Turns: $1\frac{1}{2}$	Temperature:
Spray Distance: 8"	Wet Mill Thickness:
Tip Size: 36	Dry Mill thickness:
Needle Size: 36	Date: 11-11-99
	Pre-Test

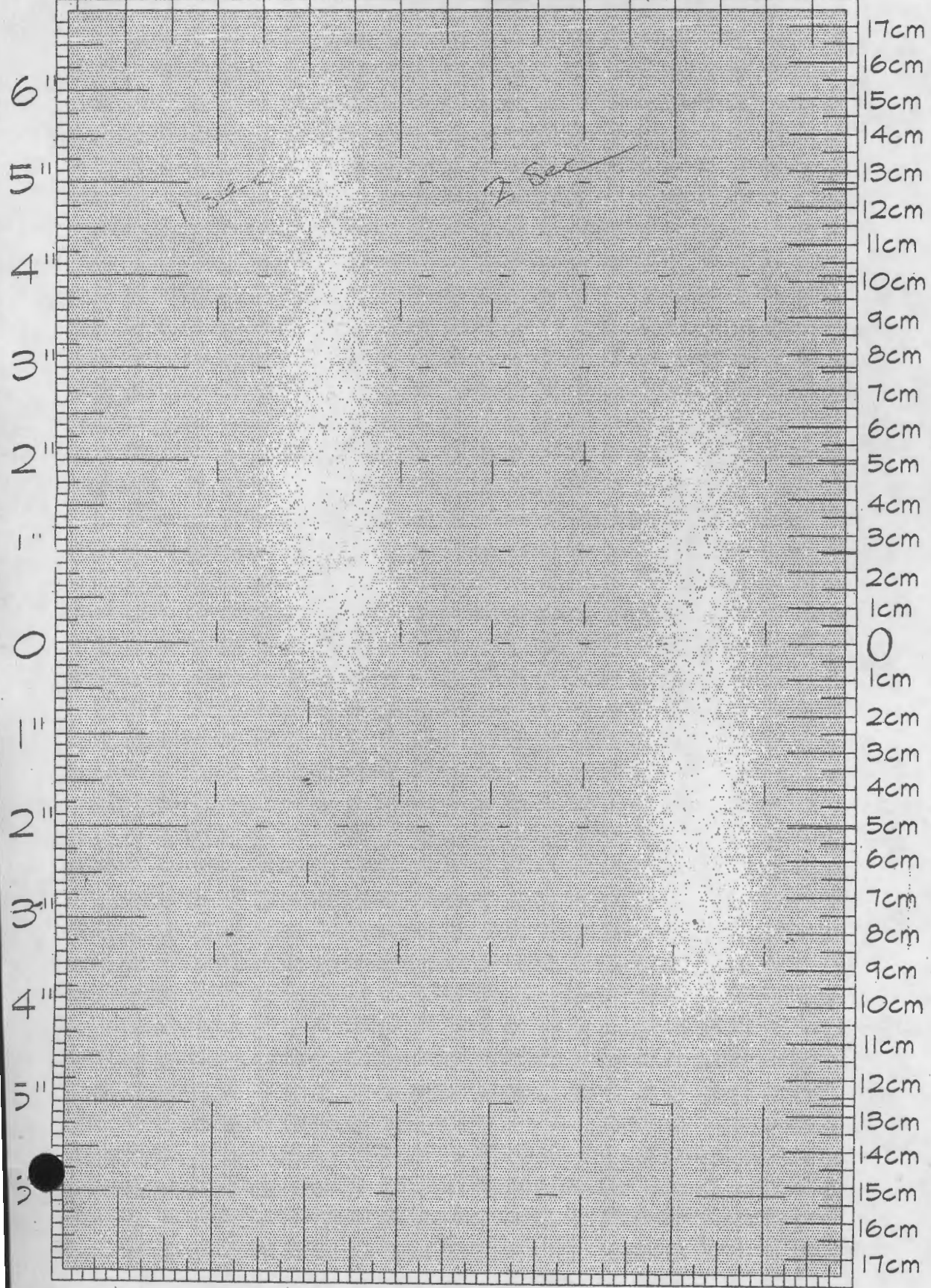

Inlet Air Pressure	Spray Technician: <i>TRAVIS</i>	
Wall Air Pressure:	Material: <i>S+K</i>	
Air Flow # Turns:	Viscosity-Ford Cup#4:	
Fluid Flow # Turns:	Temperature:	
Spray Distance:	Wet Mill Thickness:	
Tip Size: <i>36</i>	Dry Mill thickness:	
Needle Size: <i>36</i>	Date: <i>11-18-79</i>	Post-Test

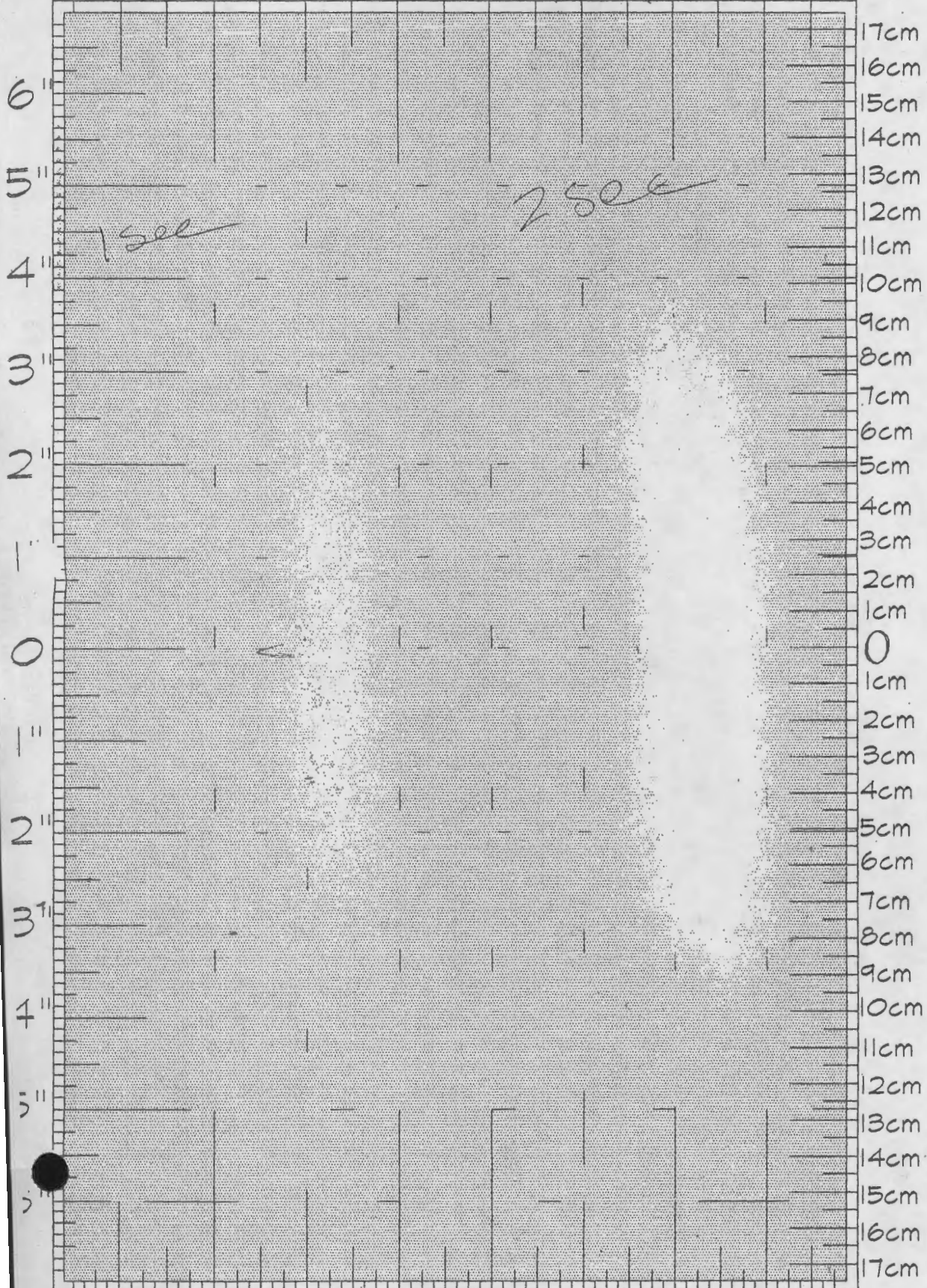

REC AP 7.

Inlet Air Pressure	40	Spray Technician:	JR Myers
Wall Air Pressure:	93	Material:	S+w Polymy
Air Flow # Turns:	1 1/2	Viscosity-Ford Cup#4:	55-62
Fluid Flow # Turns:	2 1/2	Temperature:	170.8
Spray Distance:	5"	Wet Mill Thickness:	2.5
Tip Size:	36	Dry Mill thickness:	

Needle Size: 36 Date: 11-18-97 Pre-Test

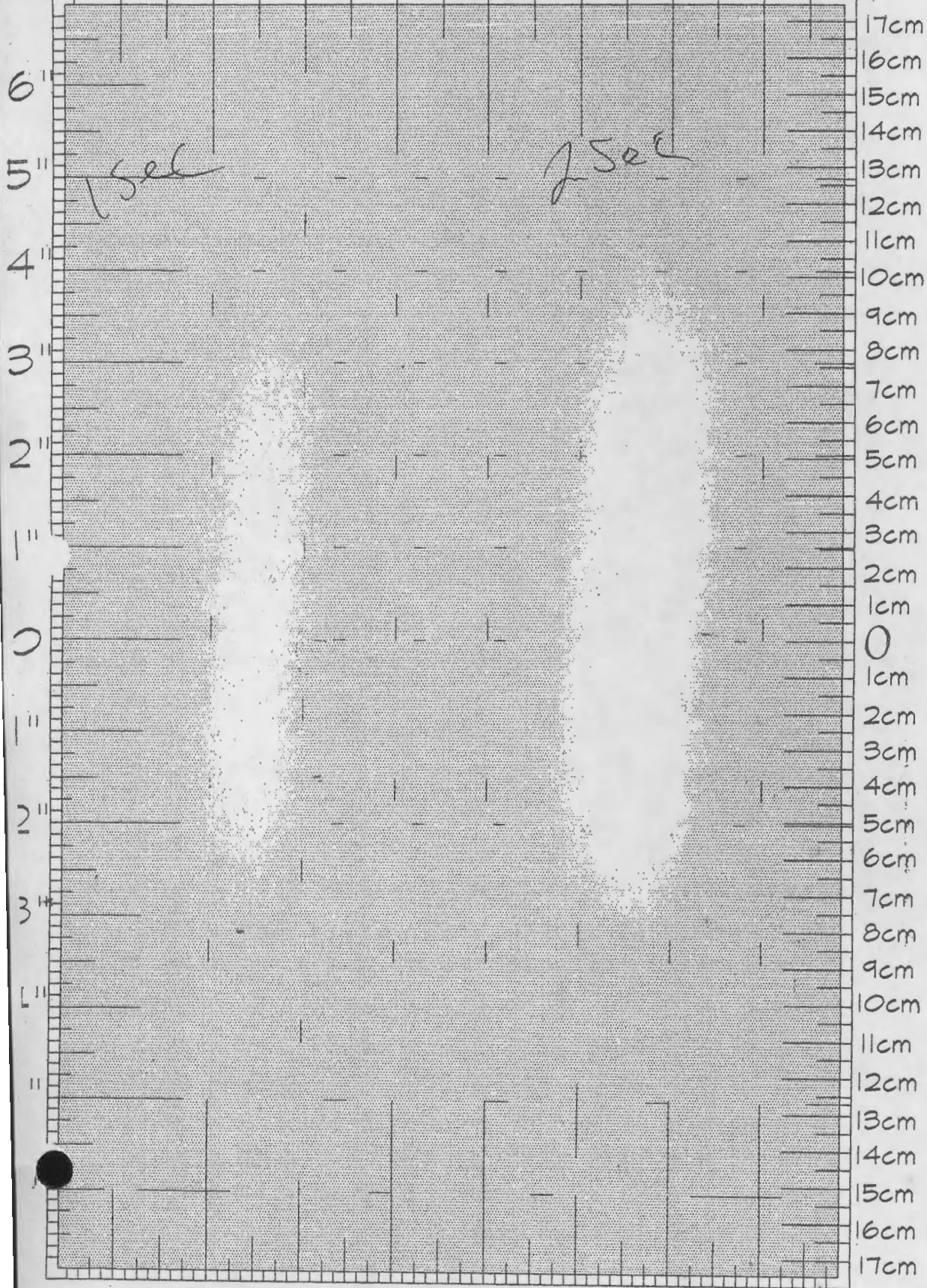

Ac 8.5

Inlet Air Pressure: 44	Spray Technician: MARIANNE MET
Wall Air Pressure: 93	Material: S+W
Air Flow # Turns: 1 1/4	Viscosity-Ford Cup#4: 56
Fluid Flow # Turns: 2 1/2	Temperature: 69
Spray Distance: 7"	Wet Mill Thickness: 2-25
Tip Size: 36	Dry Mill thickness:
Needle Size: 36	Date: 12-7-99, 12-8-99

Pre-Test

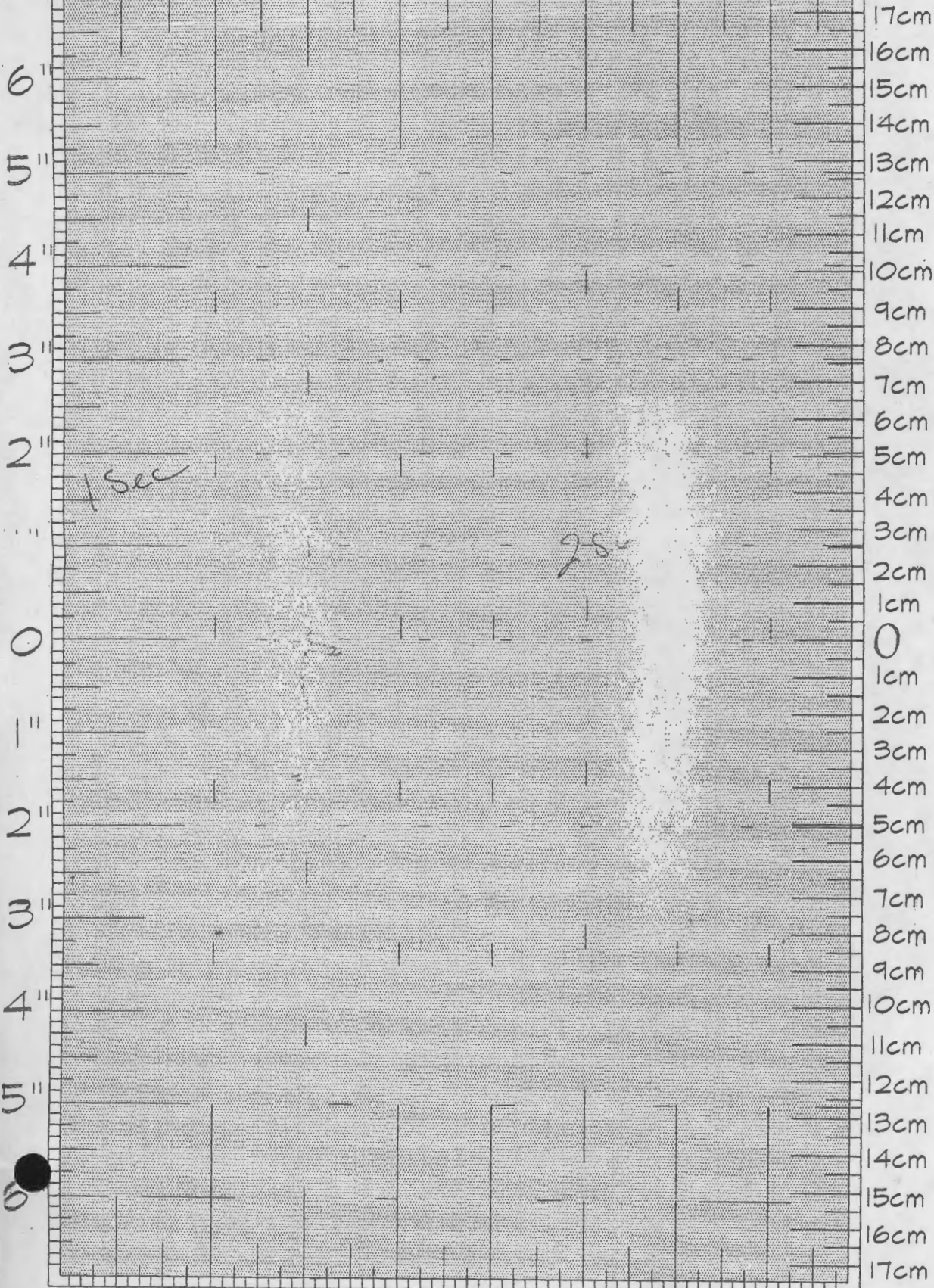

A.C. 8.5

Inlet Air Pressure: 9.44	Spray Technician: Marc M. M. M. M. M.
Wall Air Pressure: 9.3	Material: S + W
Air Flow # Turns: 1 1/4	Viscosity-Ford Cup #4: 58
Fluid Flow # Turns: 2 1/2	Temperature: 71
Spray Distance: 7 1/2	Wet Mill Thickness: 2-25
Tip Size: 36	Dry Mill thickness:
Needle Size: 30	Date: 12-7-77 12-8-77 Post-Test

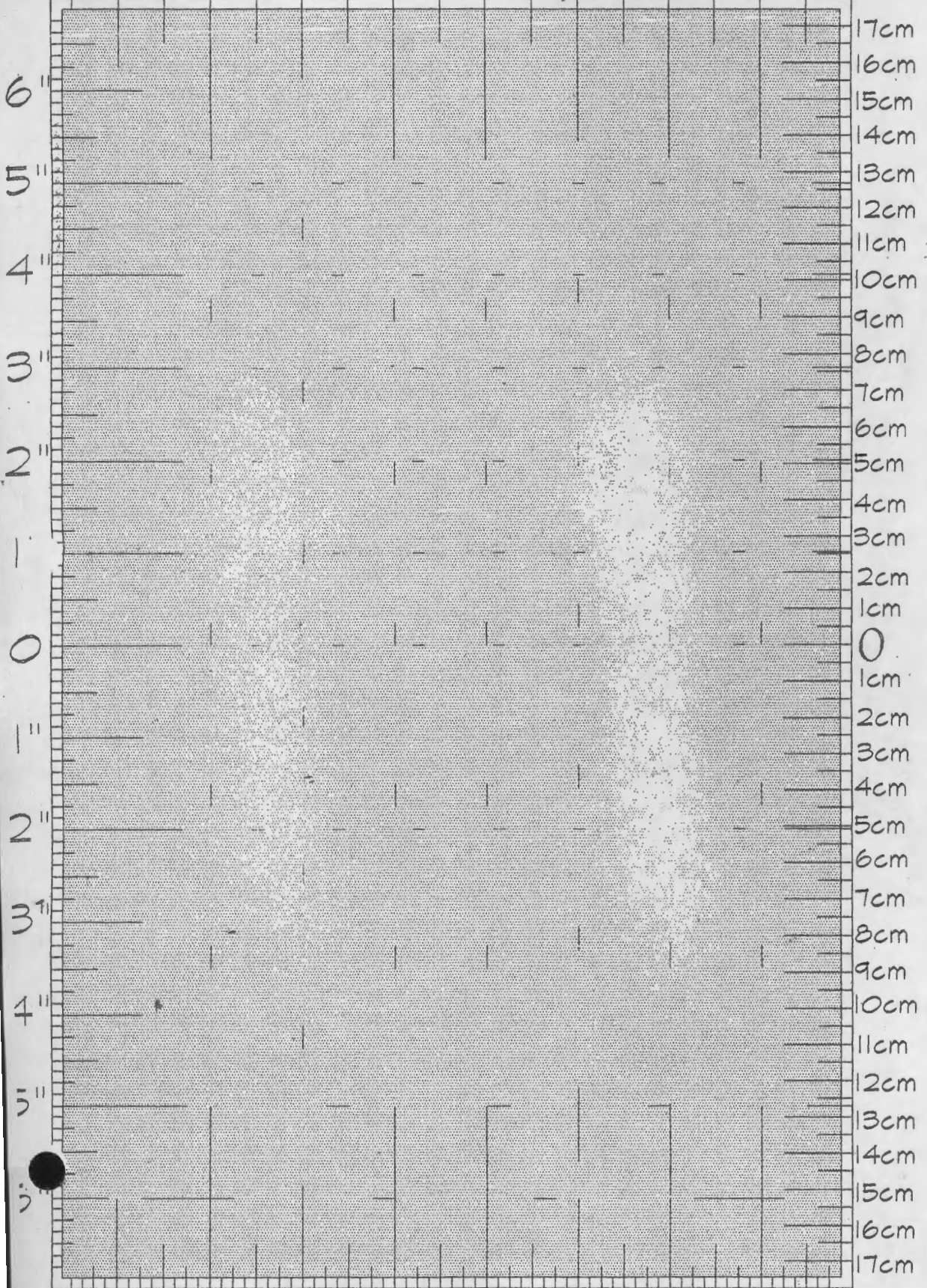

APPENDIX "L"
(RESEARCH DATA COLLECTION FORMS)

PRE-TEST DATA (W/O LASER TOUCH) - SOLID PARTS

SUBJECT		
COMPANY/SCHOOL		
DATE		
YEARS EXPERIENCE		
	SOLID PARTS (cm ²)	SOLID PARTS (in ²)
PARTS AREA	12,376.94	1,918.43

CONTROL PART			TIME:
	WEIGHT BEFORE	WEIGHT AFTER	DATE:
PART - ID	TEST (GRAMS)	TEST (GRAMS)	STAFF:

Weight / Before Spraying		TIME:
SOLID PART - ID	(Grams)	DATE:
		STAFF:

Weight / After Spraying		TIME:
SOLID PART - ID	(Grams)	DATE:
		STAFF:

STAFF:		GUN MASS (grams)					
DATE:	TIME:						

STAFF:		DATE:					
DRY FILM THICKNESS							
TIME:							
BUILD TEST							
1F							
2F							
3F							
4F							
5F							
6F							
7F							
8F							
9F							
10F							
11F							
12F							

PRE-TEST DATA (W/O LASER TOUCH) - WINDOW PARTS

SUBJECT		
COMPANY/SCHOOL		
DATE		
YEARS EXPERIENCE		
	WINDOW PART (cm ²)	WINDOW PART (in ²)
PART AREA	50,069.47	7,654.01

Weight / Before Spraying		TIME:
WINDOW PART - ID	(Grams)	DATE:
		STAFF:

Weight / After Spraying		TIME:
WINDOW PART - ID	(Grams)	DATE:
		STAFF:

STAFF:		GUN MASS (grams)					
DATE:	TIME:						
	BEFORE						
	AFTER						

STAFF:		DATE:					
DRY FILM THICKNESS							
TIME:							
1W							
2W							
3W							
4W							
5W							
6W							
7W							
8W							
9W							
10W							
11W							
12W							

POST TEST DATA (W/LASER TOUCH) - SOLID PART

SUBJECT		
COMPANY/SCHOOL		
DATE		
YEARS EXPERIENCE		
	SOLID PARTS (cm ²)	SOLID PARTS (in ²)
PARTS AREA	87,847.21	13,429.01

Weight / Before Spraying		TIME:
SOLID PART - ID	(Grams)	DATE:
		STAFF:

Weight / After Spraying		TIME:
SOLID PART - ID	(Grams)	DATE:
		STAFF:

STAFF:							
DATE:	GUN MASS (grams)						
TIME:							
BEFORE							
AFTER							

STAFF:	DATE:						
DRY FILM THICKNESS							
TIME:							
BUILD TEST							
1W							
2W							
3W							
4W							
5W							
6W							
7W							
8W							
9W							
10W							
11W							
12W							

POST-TEST DATA (W/LASER TOUCH) - WINDOW PART

SUBJECT		
COMPANY / SCHOOL		
DATE		
YEARS EXPERIENCE		
	WINDOW PART (cm ²)	WINDOW PART (in ²)
PART AREA	50,069.47	7,654.01

CONTROL PART			TIME:
	WEIGHT BEFORE	WEIGHT AFTER	DATE:
PART - ID	TEST (GRAMS)	TEST (GRAMS)	STAFF:

Weight / Before Spraying		TIME:
WINDOW PART - ID	(Grams)	DATE:
		STAFF:

Weight / After Spraying		TIME:
WINDOW PART - ID	(Grams)	DATE:
		STAFF:

STAFF:		GUN MASS (grams)					
DATE:	TIME:						

STAFF:		DATE:					
DRY FILM THICKNESS							
TIME:							
BUILD TEST							
1W							
2W							
3W							
4W							
5W							
6W							
7W							
8W							
9W							
10W							
11W							
12W							

Coatings Solids Log

STAFF MEMBER: _____

Subject: _____

Company/School: _____

Date: _____

Pre Test Solids Determination				
	TIME:	TIME:	TIME:	TIME:
DISH ID #	DISH WEIGHT (grams)	DISH WT. W/DRY SAMPLE	SYRINGE WEIGHT	SYRINGE WT. W/SAMPLE

MANUFACTURER:	SHERWIN WILLIAMS-POLANE H.S	RATIO:	
MATERIAL USED(grams):		VISCOSITY BEFORE SPRAY:	
CATALYST (grams):		VISCOSITY AFTER SPRAY:	
REDUCER (grams):		TEMPERATURE (*F):	
VOLUME MIXED (ml):		HUMIDITY (%):	

Post Test Solids Determination				
	TIME:	TIME:	TIME:	TIME:
DISH ID #	DISH WEIGHT (grams)	DISH WT. W/DRY SAMPLE	SYRINGE WEIGHT	SYRINGE WT. W/SAMPLE

MANUFACTURER:	SHERWIN WILLIAMS-POLANE H.S	RATIO:	
MATERIAL USED(grams):		VISCOSITY BEFORE SPRAY:	
CATALYST (grams):		VISCOSITY AFTER SPRAY:	
REDUCER (grams):		TEMPERATURE (*F):	
VOLUME MIXED (ml):		HUMIDITY (%):	

LABORATORY MEASUREMENTS (PRE-TEST)

SPRAY TECHNICIAN: _____

STAFF MEMBER: _____

DATE: _____

TIME:	AMBIENT CONDITIONS	
	TEMPERATURE	
	*F (Range: 77 ± 8)	
	*C (Range: 25 ± 5)	

TIME:	HUMIDITY (Range: 40% ± 15)	
	%	

TIME:	SPRAY BOOTH CONDITIONS	
	TEMPERATURE	
	*F (Range: 77 ± 8)	
	*C (Range: 25 ± 5)	

TIME:	HUMIDITY (Range: 40% ± 15)	
	%	

TIME:	SPRAY BOOTH AIRFLOW		
		NORTH SIDE	SOUTH SIDE
	ft/min(Range: 150 ± 50)		
	m/seg (Range: 0.7 ± 2)		

TIME:	PRESSURE DROP	
	inches (Range: 0.06 ± 0.1)	

TIME:	PART PARAMETERS		
	PART ID#	PART TEMPERATURE	PART TEMPERATURE
		BEFORE CURED	INSIDE OVEN
TIME:			
	*F (Range: 77 ± 8)		
	*C (Range: 25 ± 5)		

NOTE: _____

LABORATORY MEASUREMENTS (POST-TEST)

SPRAY TECHNICIAN: _____

STAFF MEMBER: _____

DATE: _____

TIME:	AMBIENT CONDITIONS	
	TEMPERATURE	
	*F (Range: 77 ± 8)	
	*C (Range: 25 ± 5)	

TIME:	HUMIDITY (Range: 40% ± 15)	
	%	

TIME:	SPRAY BOOTH CONDITIONS	
	TEMPERATURE	
	*F (Range: 77 ± 8)	
	*C (Range: 25 ± 5)	

TIME:	HUMIDITY (Range: 40% ± 15)	
	%	

TIME:	SPRAY BOOTH AIRFLOW		
		NORTH SIDE	SOUTH SIDE
	ft/min (Range: 150 ± 50)		
	m/seg (Range: 0.7 ± 2)		

TIME:	PRESSURE DROP	
	inches (Range: 0.06 ± 0.1)	

	PART PARAMETERS	
	PART ID#	PART TEMPERATURE
		BEFORE CURED
		INSIDE OVEN
TIME:		
	*F (Range: 77 ± 8)	
	*C (Range: 25 ± 5)	

NOTE: _____

DENSITY MEASUREMENTS (PRE-TEST)

STAFF MEMBER: _____

SPRAY TECHNICIAN: _____

DATE: _____

TIME:	PAINT PARAMETERS			
	TEMPERATURE		VISCOSITY-FORD CUP # 4	
	*F (Range: 77 ± 8)	*C (Range: 25 ± 5)	seg (Range: 56±6)	cSt (Range: 198 ± 35)

TIME:	DENSITY (CUP CALIBRATION)			
	WEIGHT(GRAMS)			
	EMPTY CONTAINER	H2O FILLED CONTAINER	ABSOLUTE H2O	CONTAINER
	(Range: 28.630±0.010)	(Range: 52.610±0.010)	DENSITY (g/mL)	VOLUME (mL)

TIME:	DENSITY (CONT')			
	WEIGHT(GRAMS)			
	EMPTY CONTAINER	PAINT FILLED CONTAINER	DENSITY (g/mL)	DENSITY (lb/gal)
	(Range: 28.630±0.010)	(Range: 58.850±0.15)	(Range: 1.220±0.160)	(Range: 10.50±0.98)

NOTE:

DENSITY MEASUREMENTS (POST-TEST)

STAFF MEMBER: _____

SPRAY TECHNICIAN: _____

DATE: _____

TIME:	PAINT PARAMETERS			
	TEMPERATURE		VISCOSITY-FORD CUP # 4	
	*F (Range: 77 ± 8)	*C (Range: 25 ± 5)	seg (Range: 56±6)	cSt (Range: 198 ± 35)

TIME:	DENSITY (CUP CALIBRATION)			
	WEIGHT(GRAMS)			
	EMPTY CONTAINER	H2O FILLED CONTAINER	ABSOLUTE H2O	CONTAINER
	(Range: 26.198±0.010)	(Range: 50.830±0.035)	DENSITY (g/mL)	VOLUME (mL)
				(Range: 24.710±0.10)

TIME:	DENSITY (CONT')			
	WEIGHT(GRAMS)			
	EMPTY CONTAINER	PAINT FILLED CONTAIN	DENSITY (g/mL)	DENSITY (lb/gal)
	(Range: 26.198±0.010)	(Range: 57.380±0.15)	(Range: 1.220±0.160)	(Range: 10.50±0.98)

NOTE:

CONVEYOR SET-UP

STAFF MEMBER: _____

SPRAY TECHNICIAN: _____

DATE: _____

CURE STAGE 1	
CONVEYOR SET-UP PARAMETERS	
LINE SPEED	4.1 ft/min
DWELL TIME	6 min.
TRAVEL TIME	60 sec

PANELS CURE TIME				
DATE:	PRE-TEST		POST-TEST	
	START TIME	STOP TIME	START TIME	STOP TIME

PART PARAMETERS					
PRE-TEST			POST-TEST		
TIME:					
FIRST PART ID	PART TEMPERATURE (*F)	OVEN TEMPERATURE (*F)	LAST PART ID	PART TEMPERATURE (*F)	OVEN TEMPERATURE (*F)
TIME:					
FIRST PART ID	PART TEMPERATURE (*F)	OVEN TEMPERATURE (*F)	LASTPART ID	PART TEMPERATURE (*F)	OVEN TEMPERATURE (*F)

CURE STAGE 2	
CONVEYOR SET-UP PARAMETERS	
LINE SPEED	4.1 ft/min
DWELL TIME	19 min.
TRAVEL TIME	60 sec

PANEL CURE TIME		OVEN CURE TIME	
DATE:	START TIME	STOP TIME	DATE:
			START OVEN TEMP.
			STOP OVEN TEMP.
			WEST
			EAST
		LAST PANEL ID	
TOTAL CURE CYCLE TIME			TIME:

SPRAY GUN SET-UP

DATE: _____

STAFF MEMBER: _____

SPRAY TECHNICIAN: _____

TIME:	PRE-TEST	
	WALL AIR PRESSURE	
	INLET AIR PRESSURE	
	CAP AIR PRESSURE	
	AIR FLOW # TURNS	
	FLUID FLOW # TURNS	
	AIR CAP SIZE	
	TIP SIZE	
	NEEDLE SIZE	
	SPRAY DISTANCE	
	FAN PATTERN SIZE	

TIME:	POST-TEST	
	WALL AIR PRESSURE	
	INLET AIR PRESSURE	
	CAP AIR PRESSURE	
	AIR FLOW # TURNS	
	FLUID FLOW # TURNS	
	AIR CAP SIZE	
	TIP SIZE	
	NEEDLE SIZE	
	SPRAY DISTANCE	
	FAN PATTERN SIZE	