

# the people's food project

reusing the corner store network  
for equitable food access



grace barrett  
RISD INTAR 2023



# the people's food project:

reusing the corner store network for equitable food access

A thesis submitted in partial fulfillment of the requirements for the degree Master of Design in Interior Studies [Adaptive Reuse] in the Department of Interior Architecture of the Rhode Island School of Design

By  
Grace M Barrett  
2023

Approved by Master's Examination Committee:

---

**Ernesto Aparicio**  
Senior Critic, Department of Graphic Design,  
Consultant: Graphic Design

---

**Jeffrey Katz**  
Senior Critic, Department of Interior  
Architecture, Primary Thesis Advisor

---

**Eduardo Benamor Duarte**  
Professor, Department of Interior  
Architecture, Secondary Thesis Advisor &  
Thesis Chair

---

**Wolfgang Rudolf**  
Department Head, Department of Interior  
Architecture

---

**Heinrich Hermann**  
Critic, Department of Interior Architecture,  
Secondary Thesis Advisor

---

**Barbara Stehle**  
Lecturer, Department of Interior Architecture,  
Secondary Thesis Advisor

---

**Nick Haus Heywood**  
Critic, Department of Interior Architecture,  
Adviser: Writing and Thesis Book

Copyright © 2023 Grace Barrett

All rights reserved. No part of this book may be reproduced, in any form or by any means, without the prior written permission of the author.

# acknowledgements

**Jeffrey Katz** (Senior Critic) and **Elizabeth Debs** (Critic), Department of Interior Architecture, Rhode Island School of Design, Advisors

For guiding me through the design process. I cannot thank you both enough for your thoughtful feedback and enthusiasm.

**Nick Haus Heywood** (Critic, Department of Interior Architecture) and **Jennifer Liese** (Director, Center for Arts & Language), Rhode Island School of Design, Writing Advisors

For organizing my mind and my writing.

**Tucker Houlihan** (Senior Academic Technologist, Graduate Department), Rhode Island School of Design, Consultant: Wood Design and Construction

For answering my endless list of wood-related questions.

**Pablo Bose** (Professor), Department of Geography and Geosciences, University of Vermont, External Advisor

For sharing your extensive knowledge of Vermont's refugee community.

**Brett Schneider** (Associate Professor), Department of Architecture, Rhode Island School of Design, Consultant: Structure and Materials

**Stephen Turner** (Critic), Department of Interior Architecture, Consultant: Energy, Systems, and Sustainability

**Ernesto Aparicio** (Senior Critic), Department of Graphic Design, Consultant: Graphic Design

**The INTAR 2023 Cohort**, for keeping school light and encouraging me everyday.

**My friends and family**, for too much.

**Thank you to those who welcomed me into your food initiatives, spoke passionately about food access, and answered my many questions:**

**Alisha Laramée** Program Coordinator, New Farms for New Americans, AALV

**Rose Saia** Executive Director, Centre Street Food Pantry

**Sarah Sinnott** Parent and Community Coordinator, The Family Room

**Robin McClelland** Administrative Assistant, The Family Room

**Linda Howe** Head of Volunteer Services, the Winooski Food Shelf

**Lena Greenberg** Food Access Coordinator, Intervale Center

**Anitra Conover** AmeriCorps Service Member, O'Brien Community Garden

**Julius Kolawole** President and Co-Founder, African Alliance of Rhode Island

**Julius Searight** Program Manager, Sankofa Initiative

12	abstract	88	chapter 4: food spaces
14	preface		existing program analyses
16	chapter 1: food + architecture		limitations of the food pantry
	introducing food insecurity		other food spaces
	the food assistance + architecture gap		conclusion
	people, place, and the food system	112	chapter 5: architectural precedents
	psychological comfort in design		SDA Campclar: Food Distribution Center
30	chapter 2: framework		Refettorio Gastromotiva Cafeteria
	prototype		Social Furniture
	reiteration		Kitchen-Hub
36	chapter 3: case study		Säynätsalo Town Hall
	winooski, vermont		Nest We Grow
	a brief history	126	chapter 6: design principles
	community resilience		exterior
	winooski architecture		interior
	current day		secondary elements
	food insecurity		character
	winooski's refugee population	140	chapter 7: variable design elements
	the corner stores of chittenden county	146	chapter 8: prototypical design elements
	network host structures	178	chapter 9: final design
	hub and spokes	192	bibliography
	main host structure	196	image credits

# contents

# abstract

The architectural design of spaces offering food assistance has received little to no attention since food pantries emerged in the 1970s. Non-profit food initiatives are often sited quickly with limited resources, producing inadequate spaces unable to fully support a food insecure community, prioritize the experience of users, and create a sense of belonging. The current spaces limit services to merely food distribution. They do not take advantage of the opportunity to expand socioeconomic capital through the power of shared food experiences: growing, cooking, eating, and learning.

This thesis redefines the traditional food pantry model, responding to explorations in psychological comfort in architecture, food as a connector of people and place, the design of collective spaces, adaptability as a facilitator of user autonomy, and the approachability of the corner store typology. The thesis takes on a “hub and spokes” approach, in which one main food

center providing storage, production, and service supports smaller fresh produce markets, community kitchens, and kitchen incubators. The approach is activated and contextualized through the reuse of corner stores in Winooski, Vermont, a food insecure, densely populated city with a large refugee community. In each host structure, empathetic and efficient architecture compensates for limited resources. Through a series of design principles, spaces of necessity are elevated into places of dignity, pride, and inclusion. This thesis utilizes a flexible modular design system—responsive to various needs and adaptable directly by the user—that can be implemented within a broad range of spatial configurations and building typologies. Iterations of the system can be used in both newly adapted spaces and within existing food initiatives. Due to its flexibility and responsiveness, it can be replicated to support food insecure communities across the country.

# preface

I moved to Burlington, Vermont, when I was 18 for college. I didn't go for the school; I loved Vermont, the small city, big lake, and mountains in the distance. The state loves good, fresh food, and my experience there seemed to be surrounded by it: farmers markets, locally grown produce, small food businesses, and a diverse range of restaurants. I took a handful of food systems and nutrition classes, briefly learning about food science, cooking techniques, and the life cycle of the food we buy. Like many, I had a romantic vision of the food system: the beauty of farms and the assumed ease of getting their produce at the grocery store. There are countless steps in this process that I was then blind to, not to mention the unequal access to fresh food. Insulated on the college campus, I didn't see the simultaneous abundance and scarcity of food.

I learned most about the reality of the food system from my friend Caroline, who introduced me to the county's food

insecurity and the intricate network of free distributions that helped support those in need of supplemental food. She worked for the Vermont Foodbank, coordinating the movement of produce from farms to distribution sites. She introduced me to gleaning, in which leftover crops are collected from farms after commercial harvesting. Hands in the dirt, she helped to harvest the perfectly fine, but visually imperfect, produce that would not sell to grocery stores and redistributed it to those who would use it. She also conducted research on the need for culturally preferred food options and ran a cooking program with Vermont's refugee population. She worked tirelessly throughout her college and master's programs to redirect the overabundance. She brought me leftover produce from distributions, taught me how to compost, and cooked me dinner too often to count. She showed me the power in shared food experiences, and inspired this thesis.

**chapter 1:**  
**food +**  
**architecture**



# introducing food insecurity



**“The lack of access to adequate and affordable food means that households are disenfranchised not only in terms of food, but also in their physical, emotional, and social well-being.”<sup>1</sup>**

Rebecca T. De Souza, *Feeding the Other: Whiteness, Privilege, and Neoliberal Stigma in Food Pantries*

Food insecurity—the lack of access to enough healthy and fresh food to sustain an active lifestyle—is the result of an ineffective food system in which food prices are high, grocery stores are inaccessible, culturally preferred foods are not available, and healthy, fresh food options are not given.<sup>2</sup> Across the US, the failed food system has adversely affected many low-income communities and communities of color, systematically depriving people of access to healthy and affordable food options.<sup>3</sup> This results not only in hunger, but also in unhealthy eating habits that drastically increase diet-related diseases among these communities. Repairing the food system and ensuring food security feels insurmountable due to the complexity of interrelated causes, and it ultimately calls for a large-scale approach highly dependent on policy change. However, in the absence of government intervention to address the root causes of food insecurity, food pantries have been implemented within almost every town across the country.

It is without question that food pantries have been vital in providing supplemental food to those with insufficient access; however, their reach is limited, largely due

to the lack of dignity in the traditional food pantry model and the resulting societal stigma. Suffering from a strong sense of urgency and limited funding, they often find temporary or inadequate homes within multi-use sites such as schools and church basements. These spaces are able to quickly provide food access, but are limited to providing only the basic needs of a food distribution center, mostly restricted to food storage. This lack of permanent, dedicated space not only limits the program’s support capability, but also contributes to the stigma of food assistance and inhibits its ability to create a sense of place within the community. In identifying this correlation, an opportunity to design more welcoming, comfortable spaces for food assistance presents itself.

<sup>1</sup> De Souza, Rebecca T, *Feeding the Other: Whiteness, Privilege, and Neoliberal Stigma in Food Pantries* (Cambridge, MA: MIT Press, 2019, 215-216.

<sup>2</sup> Niles, Meredith T, Farryl Bertmann, Emily H Belarmino, Thomas Wentworth, Erin Biehl, and Roni Neff. “The Early Food Insecurity Impacts of COVID-19,” *Nutrients* 12, no. 7 (2020): 2.

<sup>3</sup> Karen Washington, “Empowering Our Communities to Transform the Food System - EcoFarm 2019 Keynote,” (YouTube, 2019), <https://www.youtube.com/watch?v=FmFS6WTTWYE>.

# the food assistance + architecture gap



1966, San Francisco Diggers free food distribution

If you research “food assistance architecture,” thousands of sources will stare back at you, but nearly all of them refer to urban planning, agriculture, or even metaphorical concepts (as in the architecture of the food system itself). **The architectural design of food assistance spaces has yet to be addressed at the interior scale.** A major gap lies between these two fields, overlooking the opportunity to make an impact on this essential social service.

The initial intention of the food pantry was to provide emergency support, but over 50 years after the first one opened,

they are still consistently and heavily relied upon throughout the country. Food pantries were implemented with the expectation of impermanence in the idealistic hope that they will be temporary, that one day no one will need them and the programs can simply disband. In the meantime, available funds have been allocated towards the services offered by assistance programs, understandably prioritizing the most primitive need for food rather than designing what was thought to be a temporary space. Further, constrained resources and societal bias restricts the design process from considering



how functional and aesthetic elements can help foster healthy communities. Instead, spatial elements have been overlooked and providers are expected to serve their communities in spite of the spaces they reside in rather than in tandem with them.

Recognizing the lack of progress and priority in solving the underlying causes of food insecurity, it is probable that food pantries, and other food assistance programs, will remain relevant. The spatial needs of both the program and the user need to be addressed. These programs currently have an immediate impact on

those who use them, and with that, power in improving the lacking system on an individual and community scale. The lack of spatial design is inhibiting both the growth of food assistance programs and the experience of their users. **Not only do food pantries need to be designed, they need to be designed for permanence, at the intersection of food assistance and architecture, in which they can begin to create a more welcoming environment with a stronger sense of place.**

# people, place, and the food system

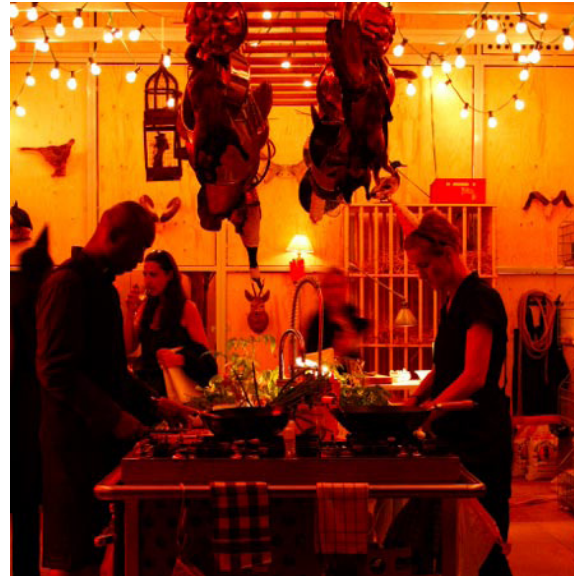

The Farm Project, Mike Meiré, Design Miami

The inadequate spatial conditions of the traditional food pantry is currently limiting services to merely food storage, impeding on the opportunity for programs to harness the full scope of the food system and encourage community resilience. Shared food experiences involving the entire lifecycle of food—growing, harvesting, preparing, cooking, and eating—can offer social interaction, cultural connection, encourage healthy eating habits, educate people on their food supply, and support a more sustainable food system. While the food pantry in particular can benefit from this type of relationship with food, it is called for among the general public, as well.

## Socialization and practices surrounding

food are inherently interwoven. Historically, food preparation and cooking was communal; at the ground level and surrounding a central point, it encouraged collective participation.<sup>4</sup> Food sharing has consistently been practiced throughout times of both food scarcity and abundance, as a way to extend the reach of limited resources or to prevent waste, celebrating food surpluses with feasts among friends and family.<sup>5</sup> Food was also seasonally and regionally relative. People knew where their food came from and how it was made, often playing a part in the growing, harvesting, and cooking processes. There was a harmonious connection between people, place, and the food system.

## supermarkets

The foodscape today, particularly in the US, is drastically different. The globalization of food and mass production of supermarket goods have completely detached people from their food source. In the book *Food Revolution 5.0*, Toya Engel and Victoria Mutzek explain a major impact of this disconnect, saying: “The seemingly inexhaustible array of offerings at the supermarkets lulls urban residents into believing that the food system is inexhaustible—when the refrigerator is empty, the nearest supermarket is never far away. Upon closer scrutiny of the agro-industrial food system, however, it becomes evident that this kind of grocery shopping as a matter of course is made possible by an economic system that is unsustainable and is gradually devouring its own foundations.”<sup>6</sup> **This over-convenient, vast variety of options has serious negative environmental, social, and economic impacts.** Mass production



and transportation of supermarket goods contributes largely to carbon emissions, increased use of food packaging, food waste, overindulgence, and neglect of the local economy.

## regional food system and food sovereignty

Recognizing the negative impacts of large scale supermarkets prompts the question: is simply implementing more grocery stores the best response to a lack of food access? The large supermarket supported by the global food trade is not a sustainable model for the individual or the climate, but a market supported by a regional foodscape is. **Smaller points of food access supported by regional farmers and producers function as a circular economy, reinvesting in itself, conserving resources, and supporting communities in the long term.** A regional food system will not only connect people with their food source, but shorten transportation routes, lessen the amount of packaging needed, and stimulate the local economy. It also educates and encourages people to make smarter, more sustainable choices at the grocery store, informed by what is seasonally available, healthy, fresh, and of better quality.

**A regional food system also provides the ability for a sense of agency and governance among community members, something lacking in both the global food trade and free food distributions.** Having a say over what food is available and how it is grown, prepared, stored, cooked, and consumed provides decision-making abilities that are often lost in mass production of food.

This agency is known as food sovereignty, the right for people to choose the way their food is produced and consumed through a fair and just food system.<sup>7</sup> A regional food system is able to be influenced and controlled by the consumer due to the smaller scale, proximity, and local ownership.

### culturally preferred food options

Food sovereignty is particularly impactful in the ability to access culturally preferred food options, specifically for refugees and those born outside of the US. The term 'globalization' is somewhat misleading. It seems like a global food trade would mean that culturally preferred food options—specifically to those who are not born in the US—would be widely available, but that is not necessarily the case. While some grocery stores have a wider variety of culturally preferred food options, they are often sourced from such lengths that the quality is poor. Additionally, as fewer stores, particularly large-scale supermarkets, are sourcing these food options, it becomes hard for smaller grocers to meet the bulk quantity necessary for wholesalers to distribute to them. Rather than importing produce from far distances, a better alternative is for a regional foodscape to grow the variety of crops that their climate is able to accommodate. Many initiatives, particularly catering to refugee populations, are exploring and encouraging farms growing culturally preferred crops and run by community members. **These are great models showing the ability to share and connect through growing, bridging the social and cultural disconnect refugees experience in transitioning to life in the US.**

### social impact

Beyond the globalization of food, we see over-convenience of food in the preparation of meals, as well. **Fast food, delivery services, microwave dinners, and pre-made meal distributions alike are stripping people of the ability to have a hand in their own food preparation, disconnecting people from the social and cultural connection in cooking, and encouraging unhealthy, less fresh food options.** People do not always turn to these options for convenience, but also cost and availability, particularly in food insecure communities. These methods of obtaining, preparing, and eating food are drawing people away from gathering for meals—both in cooking and eating—and toward individual meal times alongside other activities. The rise of technology and social media is also isolating people in a social sense when it comes to eating meals. Miho Aikawa's photo series "Dinner in New York" explores the eating 'ritual' of dinner in the modern world, capturing people eating alone in apartments, in front of work computers, texting, or watching TV. In *Food Revolution 5.0*, Aikawa wrote about this concept: "The spread of Internet, computers and

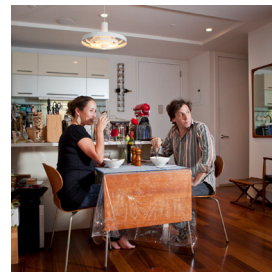
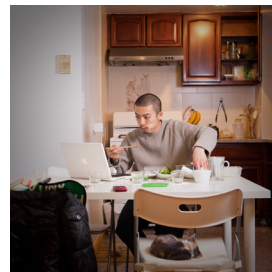

photos from "Dinner in New York," Miho Aikawa

cellphones in recent years has given people many methods of communication, and dinner has lost its original essence as an occasion to socialize with others."<sup>8</sup> Concentrating on another activity while eating distracts people from the experience of eating the food itself, and it also has negative impacts on eating habits, such as overeating. Aikawa concludes with the thought: **"When you enjoy mealtimes, you're more likely to eat better."**<sup>8</sup>

### restoring the connection

In the US today, the globalization and over convenience of unhealthy food has created a disconnect between people, place, and the food system, but this can be restored. As mentioned, a regional food scape can bridge this gap, providing autonomy, social interaction around food, and greater food access. **A network of food spaces that operate within a regional system can populate food insecure neighborhoods and facilitate these kinds of connections, fulfilling a nutritional and social need.**

<sup>4</sup> Aisslinger, Werner, "Kitchen: Communal Cooking Landscape," in *Food Revolution 5.0: Gestaltung Für Die Gesellschaft von Morgen*, ed. Claudia Banz (Verlag Kettler, 201), 57.

<sup>5</sup> Enloe, James, "Food Sharing Past and Present: Archaeological Evidence for Economic and Social Interactions," *Before Farming* 2003, no. 1 (January 2003): 3.

<sup>6</sup> Engel, Toya and Victoria Mutzek, "Kitchen: Communal Cooking Landscape," in *Food Revolution 5.0: Gestaltung Für Die Gesellschaft von Morgen*, ed. Claudia Banz (Verlag Kettler, 201), 173.

<sup>7</sup> Karen Washington, "Empowering Our Communities to Transform the Food System."

<sup>8</sup> Aikawa, Miho, "Table: Dinner in New York + Dinner in Tokyo," in *Food Revolution 5.0: Gestaltung Für Die Gesellschaft von Morgen*, ed. Claudia Banz (Verlag Kettler, 201), 97.

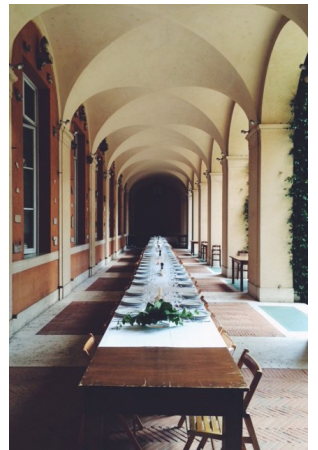

# psychological comfort in design

**“places support occupation when people feel invited to come to a place, linger and share it with others. Once there, they are more likely to bump into people and interact with one another. This requires that the place is psychologically and physically comfortable and engaging.”<sup>9</sup>**

Jenny Donovan, *Designing to Heal: Planning and Urban Design response to Disaster and Conflict*

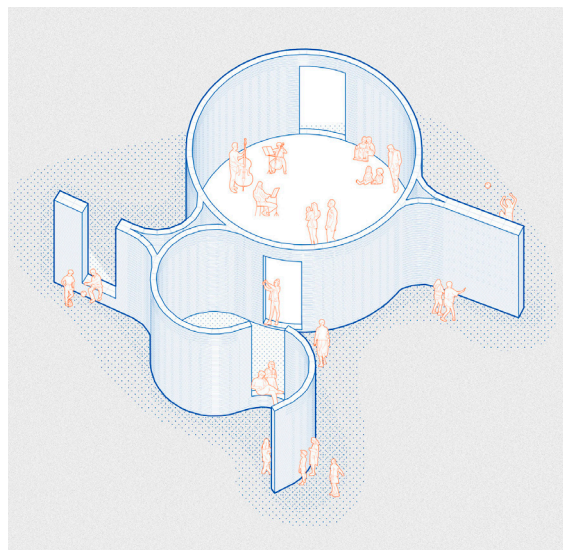

Open Wall, Anagramma Arquitectos

While I have identified a research gap in architectural design strategies related specifically to food assistance, **there is research that parallels the need for approachable, welcoming spaces that, psychologically, feel comfortable to inhabit.** People are more likely to enter, occupy, and use a space that feels comfortable, approachable, and inclusive. In the Book *Designing to Heal: Planning and Urban Design response to Disaster and Conflict*, Jenny Donovan writes, “places support occupation when people feel invited to come to a place, linger and share it with others. Once there, they are more likely to bump into people and interact with one another.

This requires that the place is psychologically and physically comfortable and engaging.”<sup>9</sup> Comfortable spaces are useful in a broad sense, for all people, but the research in this section specifically addresses trauma-informed spaces, such as in post-disaster relief, supportive housing, and abortion healthcare facilities.

**Though different sources of trauma, many experiencing food insecurity will experience similar feelings of discomfort, uneasiness, or unwanted exposure in spaces offering food assistance.** This can be due to societal stigma surrounding receiving food assistance, but there is also inherent trauma in the actual experience of not having secure access to food. When you do not know where your next batch of groceries or meal will come from, there is a consistent worry in finding it.

## visual connection to food source

In an interview with Alisha Laramee, the program coordinator for the New Farms for New Americans program at the refugee support center Association of Africans Living in Vermont (AALV), she discussed this feeling of insecurity in relation to refugees. Laramee explained the feeling surrounding the inability to see one’s food source, a result of the globalization of food, the lack of growing space in urban areas, and the shorter growing season in Vermont. **Many of the refugees Laramee works with had visual access to their food source prior to coming to the US; they felt secure in their access to food because they could always see it, and often had a hand in growing it.** Laramee also

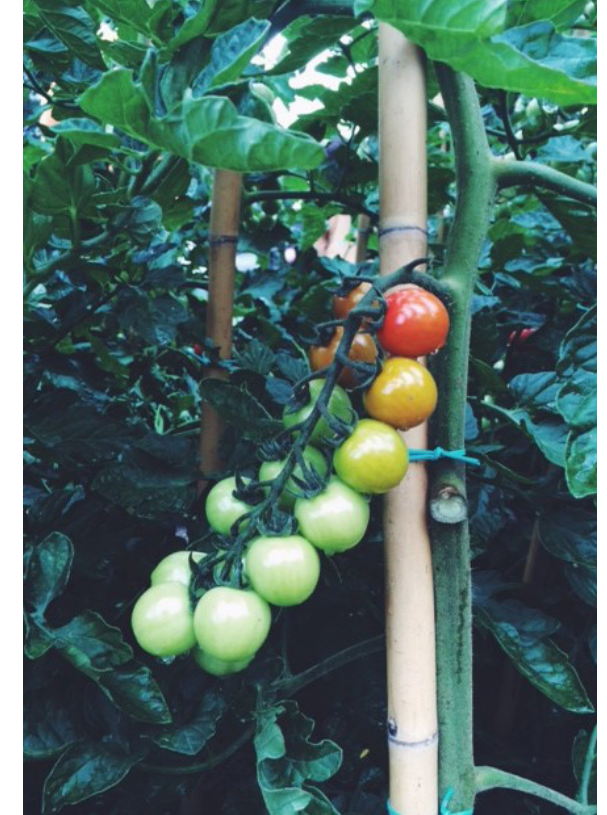

mentioned feelings of safety in a physical sense. When building a shed intended for covered seating at the farm, she slatted the horizontal pieces of wood with gaps between each plank, so the people on the inside could see 360 degrees around them. This was both for providing visual access to nature and food growing, responding to the need for safety in seeing and controlling one’s own food source. In fact, the psychological effect of connection to nature is discussed in Kara Boboski’s thesis “A Client-Focused Abortion Health Centre: Creating a Sense of Comfort and Security through the Built Environment.” Boboski writes, “It is evident that there is a desire for human connection to nature, so naturally, there is a positive response when exposed to natural elements. Nature has a common association with positive feelings and serenity, and is proven to promote wellbeing.”<sup>10</sup>



the New Farms for New Americans' Shed

## physical safety

Laramie created the slatted wall system to invoke both the feeling of physical safety in being able to see those approaching and the comfort of being somewhat obscured from onlookers. This is particularly important for the women at the farm, who experience trauma related to their displacement and feel vulnerable in the open, but heavily vegetated, farm. There is a strong correlation between threshold permeability and the experience of users in this research area. In “Architectural Design Characteristics, Uses, and Perceptions of Community Spaces in Permanent Supportive Housing,” Yelena McLane and Jill Pable support this correlation when discussing psychological safety in crossing thresholds. They explain, “People feel more comfortable making space use decisions when they can see and assess from a safe distance who is in the space and whether they want to join.”<sup>11</sup> **Having visual connection through the threshold makes people feel comfortable in entering a space, knowing what lies ahead. However,**

**a balance is called for. A threshold that is overly transparent exposes the people inside, and fails to provide discretion, specifically in instances of food assistance where privacy is called for.**

## physical and visual connection

Jenny Donovan addresses thresholds in *Designing to Heal*, saying “Psychological comfort also requires that points of entry feel like thresholds across which people move, rather than gates that exist to restrict or control who can enter.”<sup>12</sup> This begins the discussion of free circulation, in which users are encouraged to inhabit each space, unobstructed by major physical barriers. Users should not feel shocked or overwhelmed upon approaching, entering, or moving through the building in terms of spatial conditions. They will have sufficient visual and physical connection through boundaries to ensure that approaching and crossing them feels comfortable. **Their ability to inhabit the space freely and how they wish instills a sense of autonomy in the user, and the feeling that the space partially belongs to them.**

Additionally, Donovan discusses the capacity for spaces to be welcoming when their activity spills out into the exterior of the building.<sup>13</sup> Activating exterior space, for activities with a more public distinction, makes it easily visible to those passing by and encourages them to engage. **Both visual connection between people and activity across boundaries and the feeling of belonging aids in the overall collectivity of the environment.**

## adaptability

In addition to thresholds, autonomy in space can be achieved through adaptability. Donovan goes on to discuss this, saying, “Flexibility is a quality a place has when it can be adapted to continue to meet people’s needs as circumstances change. This requires it stays relevant and adaptable.”<sup>14</sup> **Flexibility in both the short term, as modifying physical elements of the space, and long term, as ability to modify the space over time, provides users the ability to physically adapt the space to best suit their current and evolving needs.** In short, being community controlled enables a space to remain relevant.

## simple, cost efficient, and clean

In terms of construction and materiality, Donovan says “low cost and simple [construction] will create a connection between the place and the people it serves and can help ensure that a place can respond to changing needs.”<sup>15</sup> **She also explains adaptive reuse and simple material and construction as parts of a more cost efficient approach for small, local and start-up businesses, who typically rent lower-cost spaces in older buildings.**<sup>16</sup> Additionally, **materials and spaces that are easy to keep organized and clean have a major impact on the perception of the space, and the feeling users experience, particularly in environments which have an inherent societal stigma.** McLane and Pable discuss this in regards to supportive housing, saying that “actual and perceived cleanliness affects

the sense of dignity and self-esteem for persons who have experienced homelessness as the “inability to remain clean” is central to stigmatization of this group of people and perpetuates a feeling of inferiority, dysfunctionality, and abjection.”<sup>17</sup> While many people who are food insecure have homes, there is a societal overlap that reinforces similar stigmas surrounding provision of resources for unhoused people and those who are food insecure. This is partly due to the overlap of the user group, but also in the common insufficiency of their spaces and the negative connotation associated with them. The joint stigma is partly a result of the quality of these spaces; addressing quality can drastically impact both user and worker experience and weave dignity into food assistance.

<sup>9</sup> Donovan, Jenny, “The Characteristics of Places that are Designed to Heal” in *Designing to Heal: Planning and Urban Design Response to Disaster and Conflict*, (Collingwood, VIC: CSIRO PUBLISHING, 2013), 263.

<sup>10</sup> Boboski, Kara, “A Client-Focused Abortion Health Centre: Creating a Sense of Comfort and Security through the Built Environment,” (Winnipeg: University of Manitoba, 2019), 22.

<sup>11</sup> McLane, Yelena, and Jill Pable, “Architectural Design Characteristics, Uses, and Perceptions of Community Spaces in Permanent Supportive Housing,” *Journal of Interior Design* 45, no. 1 (March 2020): 46. <https://doi.org/10.1111/joid.12165>.

<sup>12</sup> Donovan, “The Characteristics of Places that are Designed to Heal” in *Designing to Heal: Planning and Urban Design Response to Disaster and Conflict*, 264.

<sup>13</sup> Donovan, 263.

<sup>14</sup> Donovan, 272.

<sup>15</sup> Donovan, 272-3.

<sup>16</sup> Donovan, 262.

<sup>17</sup> McLane, Yelena, and Jill Pable, “Architectural Design Characteristics, Uses, and Perceptions of Community Spaces in Permanent Supportive Housing,” 47.

# chapter 2: framework

# prototype

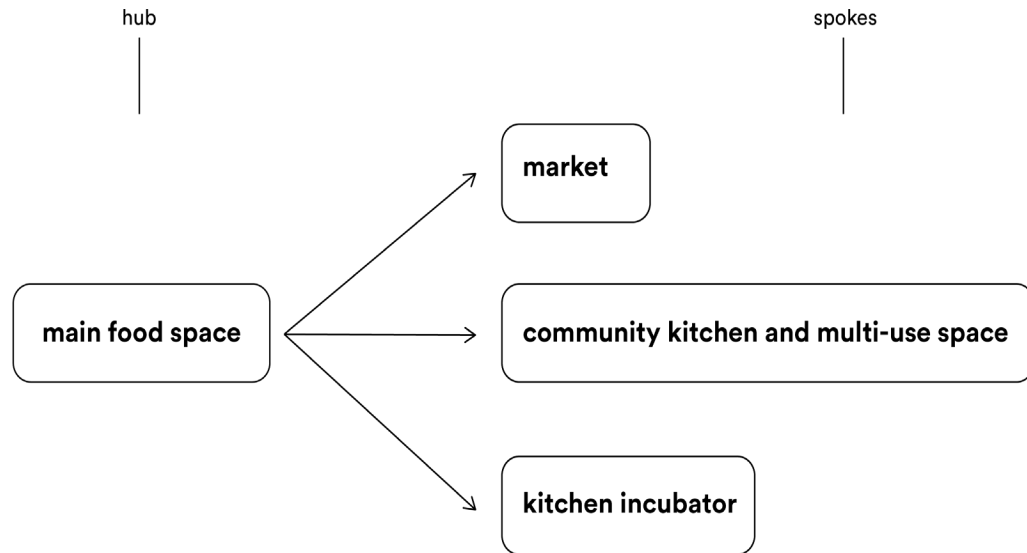

**This thesis addresses food insecurity, stigma, and the limitations of the food pantry in high density, low income neighborhoods through a prototype that restructures food assistance, both architecturally and programmatically.** The traditional food pantry model is redefined, pulling inspiration from current food spaces, architectural projects, and the existing network of corner stores. Food distribution is removed from religious affiliations, schools, and parking lots, and permanently placed within existing corner stores, modifying the established community space to encourage a host of shared food experiences: growing, cooking, eating, sharing, and learning. Both clients and workers are better served through

approachable, comfortable, functional, and efficient design, with attention to the specific preferences of users across cultural backgrounds, particularly regarding food practices. This model not only provides nutritional assistance and social interaction, but a permanent and consistent food space reflective of both the life cycle of food and the people it serves.

**The prototype functions as a hub and spokes model: one main food center supporting a series of small food spaces—a fresh produce market, kitchen incubator, and community kitchen and dining space.** This approach coordinates with existing food initiatives, filling the current gaps in order to serve communities comprehensively;

going beyond emergency food distribution, these food spaces offer opportunities for social and economic growth, autonomy and sovereignty, a more sustainable food system, and an inclusive public space. Smaller implementations scattered throughout food insecure neighborhoods become easily accessible, able to reach the community directly where there is a need. Underused pockets of space within high density, low-income areas are revitalized, responding to their lack of unused, high volume square footage. Permanently embedding food

assistance within established corner store networks honors the role of the corner store in historically filling food access gaps.

**The prototype displays the implementation of design principles (outlined in chapter 6) and prototypical elements (outlined in chapter 8) within a host structure in Winooski, Vermont. These elements can be applied within a broad range of existing building typologies and services, able to further guide the design of food assistance spaces.**

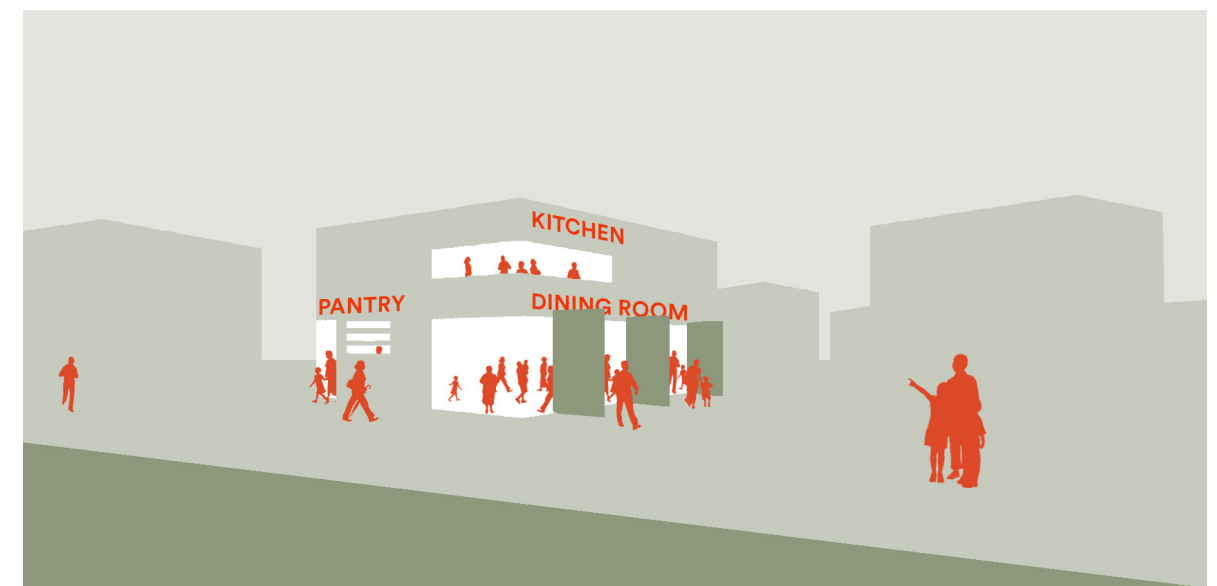



# reiteration

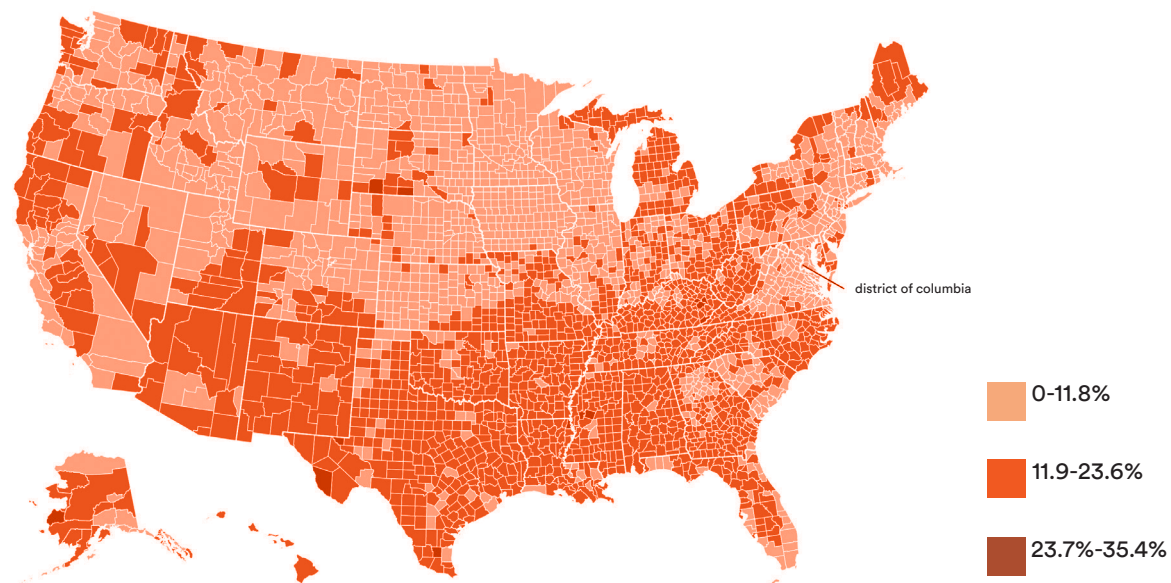

Feeding America's map of food insecurity rates among all ages in the United States, by county, 2021

In order to address large-scale issues within the food system, this thesis proposes a network of these models, partnered with local food assistance programs, farmers, and start-up food businesses, sited within corner stores, and iterated within food insecure communities across the country. One implementation will not be enough, but the case study of Winooski, Vermont demonstrates the prototype's abilities at community level and within the main host structure. As the project is reiterated, its impact grows as more communities are served.

Potential host structures for reiterating this model will reveal themselves through the ways in which they are suited to both the general requirements of food pantries and the communities' varied needs and preferences. Corner stores that are currently underutilized, at risk of becoming obsolete,

or with potential to be expanded are to be prioritized as a way to find new uses for existing structures while preserving its nostalgic character. The following list further details characteristics of potential host structures:

- within low-income neighborhoods;
- walkable and/or easily accessible by public transportation;
- nearby frequented buildings or sites, such as schools, community centers, assistances services, etc;
- truck accessible for food deliveries;
- available parking on site or nearby

Within each community, analyzing the specific user group will yield better results in creating a space that best serves each individual community.

# chapter 3: case study

# winooski, vermont

1920s, panorama of the Winooski river and mills



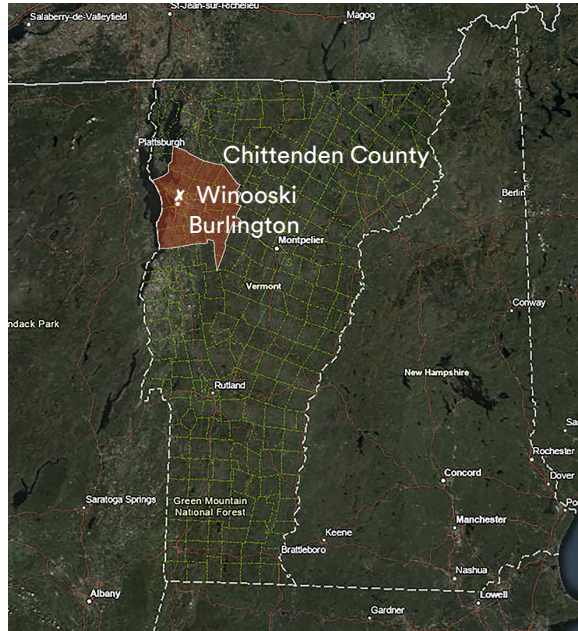

Vermont state map, Chittenden County and the state's densist cities, Winooski and Burlington marked

Winooski is a small post-industrial city in Vermont's Chittenden County. With 1.5 square miles and a population of nearly 8,000, it is the most densely populated municipality in northern New England, according to the 2020 census.<sup>12</sup> The city sits on a hill with the Winooski River at its base, and Burlington, Vermont's largest city, across the river.<sup>13</sup>

<sup>12</sup> "QuickFacts: Winooski City, Vermont," U.S. Census Bureau.

<sup>13</sup> "Historic Resource Inventory & Preservation Bylaw City of Winooski," City of Winooski, 9-10.

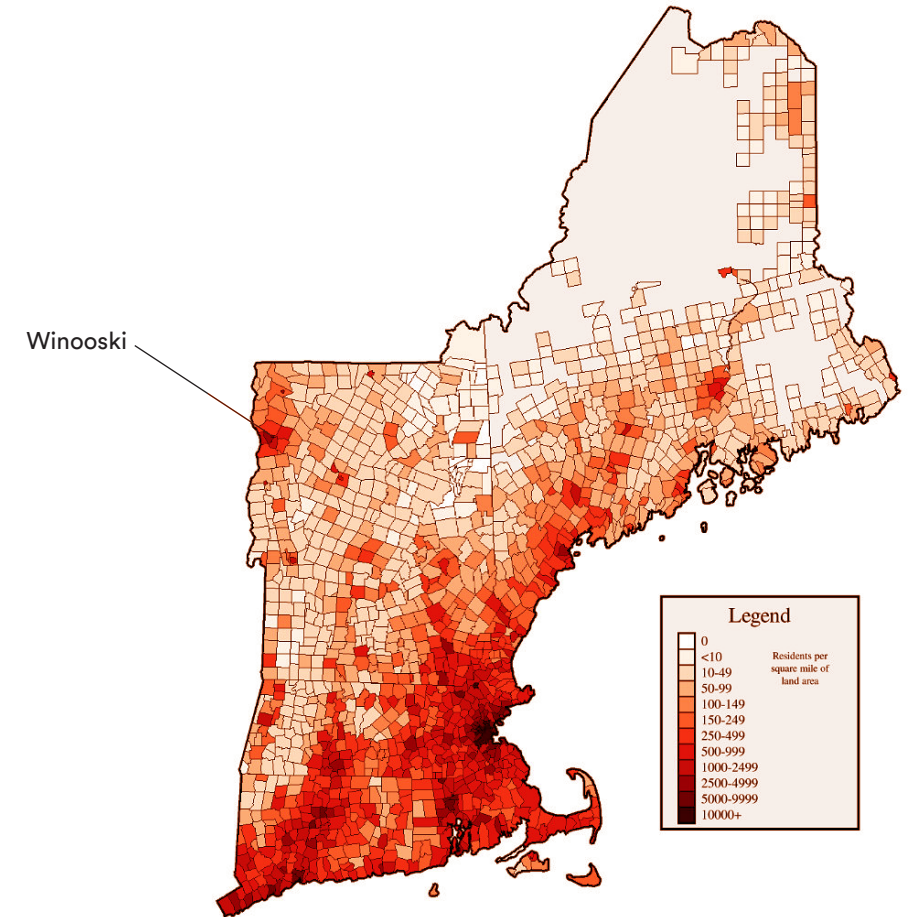

The population density of New England's municipalities, based on land area and 2010 US census population data, showing Winooski as the densest in northern New England

# a brief history

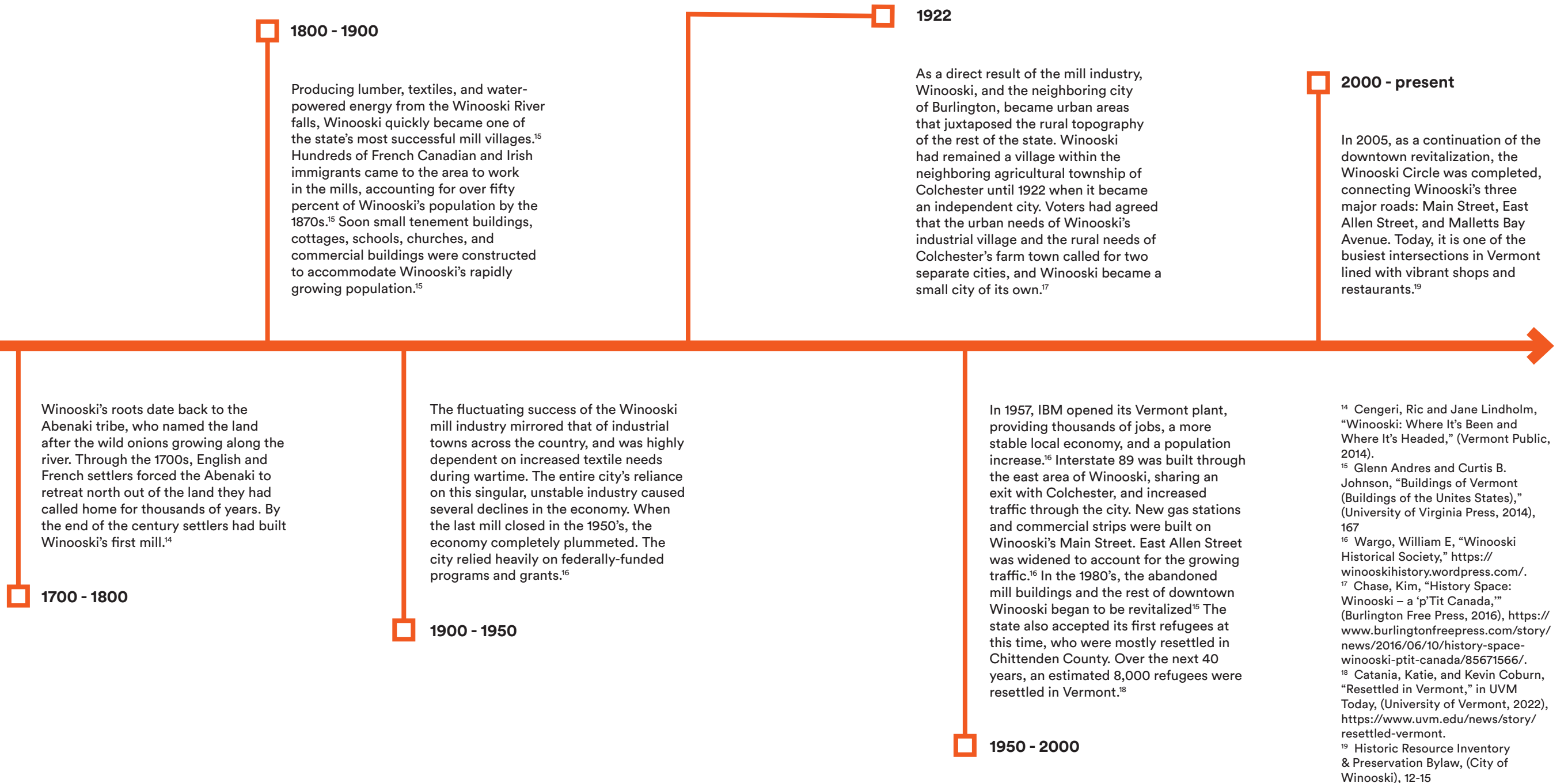

<sup>14</sup> Cengeri, Ric and Jane Lindholm, "Winooski: Where It's Been and Where It's Headed," (Vermont Public, 2014).  
<sup>15</sup> Glenn Andres and Curtis B. Johnson, "Buildings of Vermont (Buildings of the Unites States)," (University of Virginia Press, 2014), 167  
<sup>16</sup> Wargo, William E, "Winooski Historical Society," <https://winooskihistory.wordpress.com/>.  
<sup>17</sup> Chase, Kim, "History Space: Winooski – a 'p'Tit Canada," (Burlington Free Press, 2016), <https://www.burlingtonfreepress.com/story/news/2016/06/10/history-space-winooski-ptit-canada/85671566/>.  
<sup>18</sup> Catania, Katie, and Kevin Coburn, "Resettled in Vermont," in UVM Today, (University of Vermont, 2022), <https://www.uvm.edu/news/story/resettled-vermont>.  
<sup>19</sup> Historic Resource Inventory & Preservation Bylaw, (City of Winooski), 12-15

# community resilience



1935, Mount St. Mary's, wait staff stands ready to serve Christmas Dinner

**“Though hard economic times caused numerous stresses in Vermonters’ lives, they continued to find joy and support in social celebrations. Urban areas, with their larger populations and diverse neighborhoods, supported numerous social, political, and fraternal organizations. Not only did these organizations provide under-represented groups a voice in labor and politics, they also provided food, fellowship, and social interaction.”<sup>20</sup>**

The Vermont Historical Society,  
“Creating an Image: Reality of Life in Vermont”



1957, women of the Ladies Auxiliary pose with food basket about to be delivered to those in need

The city of Winooski, and Vermont as a whole, has been susceptible to economic influences throughout its entire history, but nevertheless it has held a strong community. It was common for churches to host communal dinners as a way to supplement the community's meager food supplies. It also happened to be a socially rewarding space that hosted communal modes of entertainment like music, dancing, and sports. It allotted time of joy and a sense of collectivity in the lives of hard-working Vermonters.<sup>20</sup>

Today, a host of community assistance programs operate out of Chittenden County, offering vital support to Vermonters. The city of Winooski has been working at developing its community services and relationships, playing a major role in community resilience, as it has throughout its history.

<sup>20</sup> Berolzheimer, Alan and Michael Sherman, eds., "Creating an Image: Reality of Life in Vermont" in Vermont Historical Society's Freedom & Unity exhibit. (Vermont History, 2006).



1948, Camp Marycrest, adults and children form a line alongside tables of food

# winooski architecture

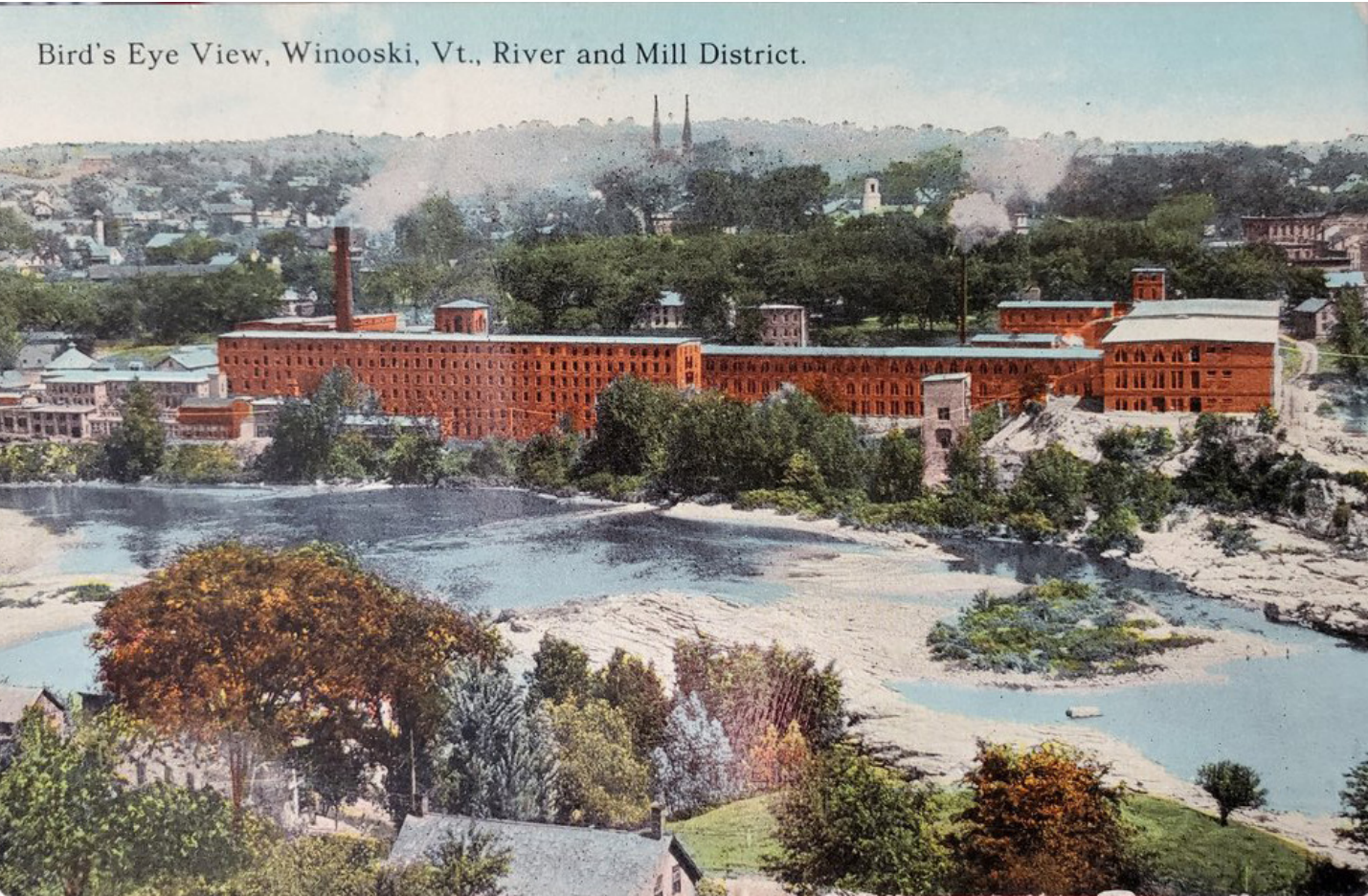

Winooski's industrial section, harnessing hydro-power and manufacturing textiles and woolen goods, 1837 to 1954



Postcard of the Winooski Bridge and Flouring Mill prior to its destruction in the Flood of 1927

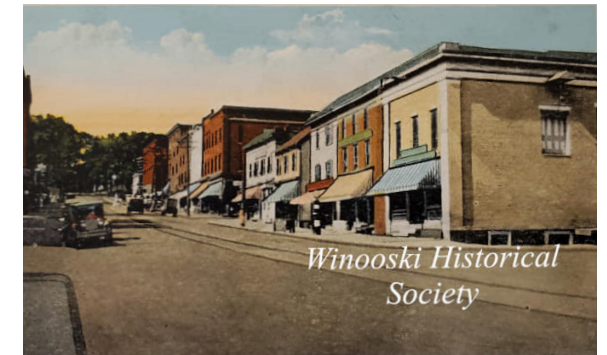

1920, postcard showing some of Winooski's storefronts, including the Winooski Fruit Market



The built environment formed by Winooski's industrial history challenges the stereotypical rural Vermont archetype in both architecture and landscape. While Vermont is known for its barns and covered bridges set against rural farmland, Winooski offers an equally rich but more diverse architectural makeup, heavily influenced by immigrants and the mill industry, set against an urban landscape. Thousands of historic buildings still stand throughout the city, many of which are listed on the National and State Registers of Historic Places. Winooski values its architectural history greatly and "remains Vermont's best preserved textile mill village."<sup>21</sup>

In April of 2006, the Advisory Council on Historic Preservation designated the city of Winooski as a Preserve America Community, which "honors communities that protect and celebrate heritage, use their historic assets for economic development and community revitalization; and encourage people to experience and appreciate local historic resources through education and heritage tourism programs."<sup>22</sup>

<sup>21</sup> Glenn Andres and Curtis B. Johnson, "Buildings of Vermont (Buildings of the United States)," 167

<sup>22</sup> "Preserve America, Winooski, Vermont," Advisory Council on Historic Preservation, 2006, <https://www.achp.gov/preserve-america/community/winooski-vermont>.



1929, a corner store advertises cigars, cigarettes, and Salada Tea with the bridge connecting Winooski and Burlington in the background



Sometime between 1885 and 1893, the intersection of Allen and Main Streets



1969, a snowy Main Street hill

# current day

Aerial view over the downtown Winooski Circle



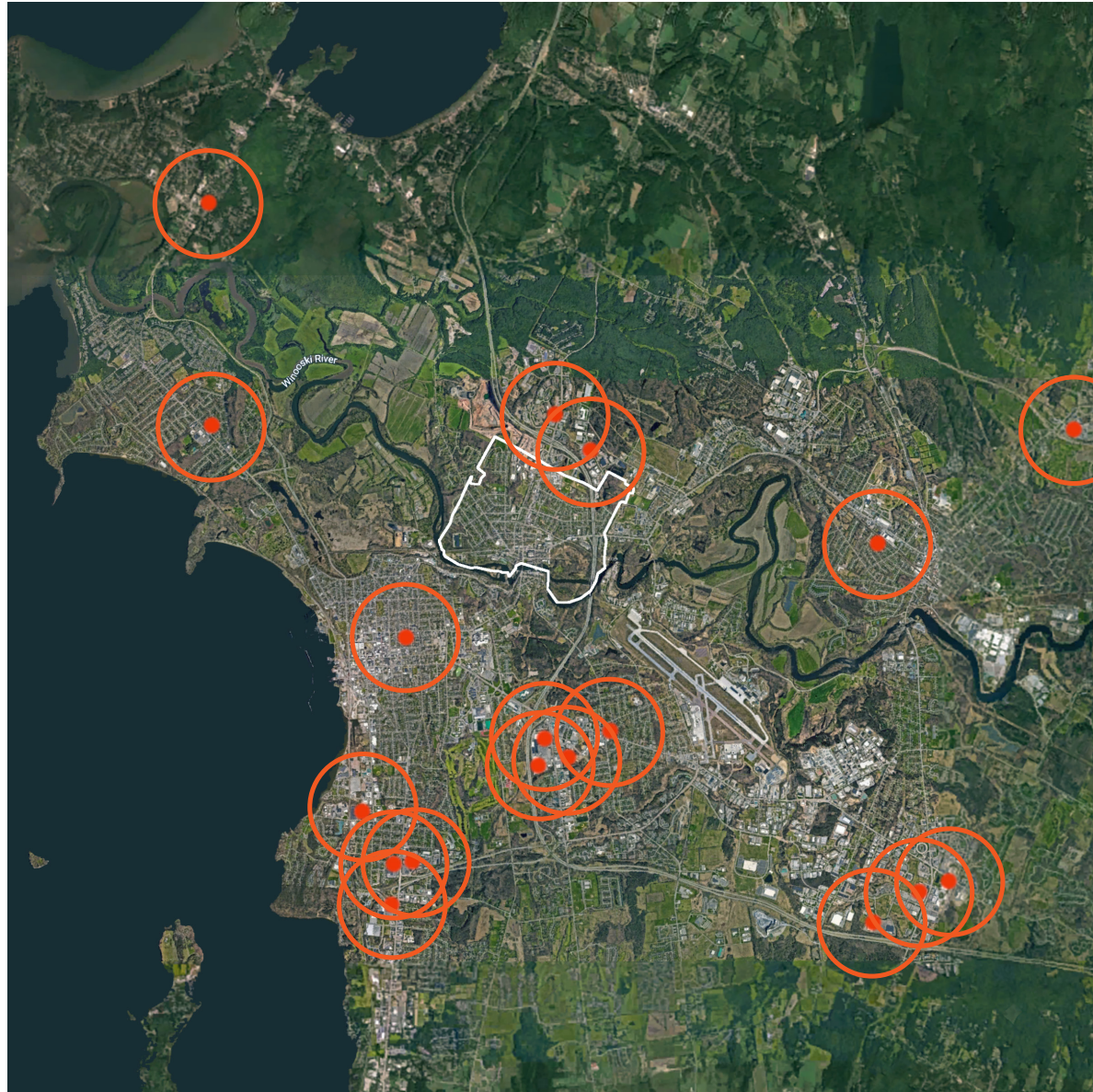

In this map, Winooski is outlined in white and all full service grocery stores in the area are marked by red dots with a half mile radius indicated. It can be seen how no grocery stores are located in Winooski, and only a small area is within a half mile of the nearest grocery store.

Today, downtown Winooski is populated with restaurants and stores mostly located around the Winooski Circle. The city's efforts at revitalizing this area yielded success in the commercial sector; however, Winooski continues to have deeply rooted economic instability, with a poverty rate of 22.5%, a high percentage in comparison to the state's poverty rate of 10.8%, according to the 2020 census.<sup>23</sup> Though Vermont's demographics remain primarily white, Winooski is the most diverse city in the state, largely due to their refugee population. In fact, 14.2% of Winooski's population was born outside of the US, greater than Burlington's 9%—also home to resettled refugees—and significantly higher than the state's overall 4.4%.<sup>23</sup>

Winooski's size, density, and diversity make it unique among rural Vermont, requiring different needs than the rest of the state. It is similar to Burlington, but is much smaller, less developed, and with fewer resources. The urban environment cannot accommodate a full service grocery store nor its accompanying parking lot, and it is lacking in adequate indoor public space. Though Winooski itself is extremely walkable, it is not as easy to access Burlington or other surrounding towns without a car. The public transportation system is not as reliable, frequent, or accessible as other cities, making it harder to access the existing grocery stores.

<sup>23</sup> "QuickFacts: Winooski City, Vermont."

# food insecurity

## winooski

Studies on Winooski's specific food insecurity have not been conducted, but in comparing Winooski's poverty rate of 22.5% and the overall state of Vermont's poverty rate of 10.8%,<sup>24</sup> and acknowledging the inaccessibility of grocery stores, it can be concluded that Winooski residents are particularly vulnerable to food insecurity.

## vermont

A series of statewide surveys conducted by the University of Vermont between March and September of 2020 found that 29% of Vermont is food insecure, an increase from 18% before the pandemic.<sup>25</sup> One-third of respondents had accessed some type of food assistance program since the pandemic and 15% had used a food pantry. Over 70% of all respondents expressed feelings of anxiety in regards to accessing food.<sup>25</sup>

Though many food assistance programs are available to Vermont residents, many people do not utilize them even when they are aware of their existence. **The study found that stigma and logistical concerns acted as barriers for residents to seek food assistance; specifically, over one-third of respondents said they did not want to use a food pantry because they value personal independence and one-fifth expressed concern that people would find out.**<sup>25</sup>

A later study conducted by the same research team in November of 2021 identified 6 Key findings:

1. "The number of Vermonters using food assistance programs grew by 86.7% between March 2020 and March 2021 from 24.8% to 46.4%."
2. "Vermonters using food assistance programs were more likely to have lower incomes and education levels, to have children, or to have experienced job disruption during the pandemic than those that did not use food assistance programs."
3. "BIPOC/Hispanic Vermonters were more likely to use community-based food assistance programs (compared with federal food assistance programs) than non-Hispanic white Vermonters."
4. "Worries about the qualifications, logistics, and stigma involved in using food programs grew between May/June 2020 and March 2021."
5. "Experiences and perceptions of food assistance program use vary significantly between individuals using federal programs, community programs, or a combination of the two."
6. "There are significant demographic differences between groups of people using federal programs, community programs, or a combination of the two."<sup>26</sup>

## winooski residents, the user group

Insufficient access to food in Winooski has led many residents to participate in unhealthy eating habits, such as rationing their food intake, skipping meals, eating less fresh food, and turning to more affordable but unhealthy fast food options. This thesis project supports this particular section of the local community.

The objective of this project is to prioritize the experience of those receiving food assistance, but it also views food assistance programs, and their workers, as part of the user group. Whether a person is there to work, volunteer, or receive food, they

are a community member in which this project strives to engage and build a sense of collectivity. Even those who are not food insecure are located far from a grocery store and would benefit from this network of food spaces. **Ultimately, this project serves all members of the community.**

<sup>24</sup> "QuickFacts: Winooski City, Vermont."  
<sup>25</sup> Niles, Meredith T, Emily H Belarmino, and Farryl Bertmann, "COVID-19 Impacts on Food Security and Systems: A Third Survey of Vermonters," (November 2020).  
<sup>26</sup> Burke, Madeleine, Ashley C McCarthy, Emily H Belarmino, Farryl Bertmann, and Meredith T Niles, "Food Security and Assistance Programs in Vermont Before and During COVID-19," (2021), 1.

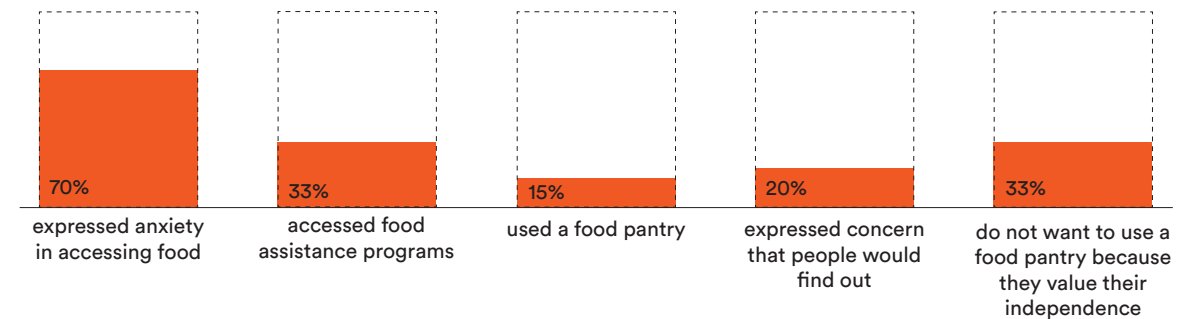

findings from a UVM study on food insecurity and assistance programs in Vermont

# winooski's refugee population

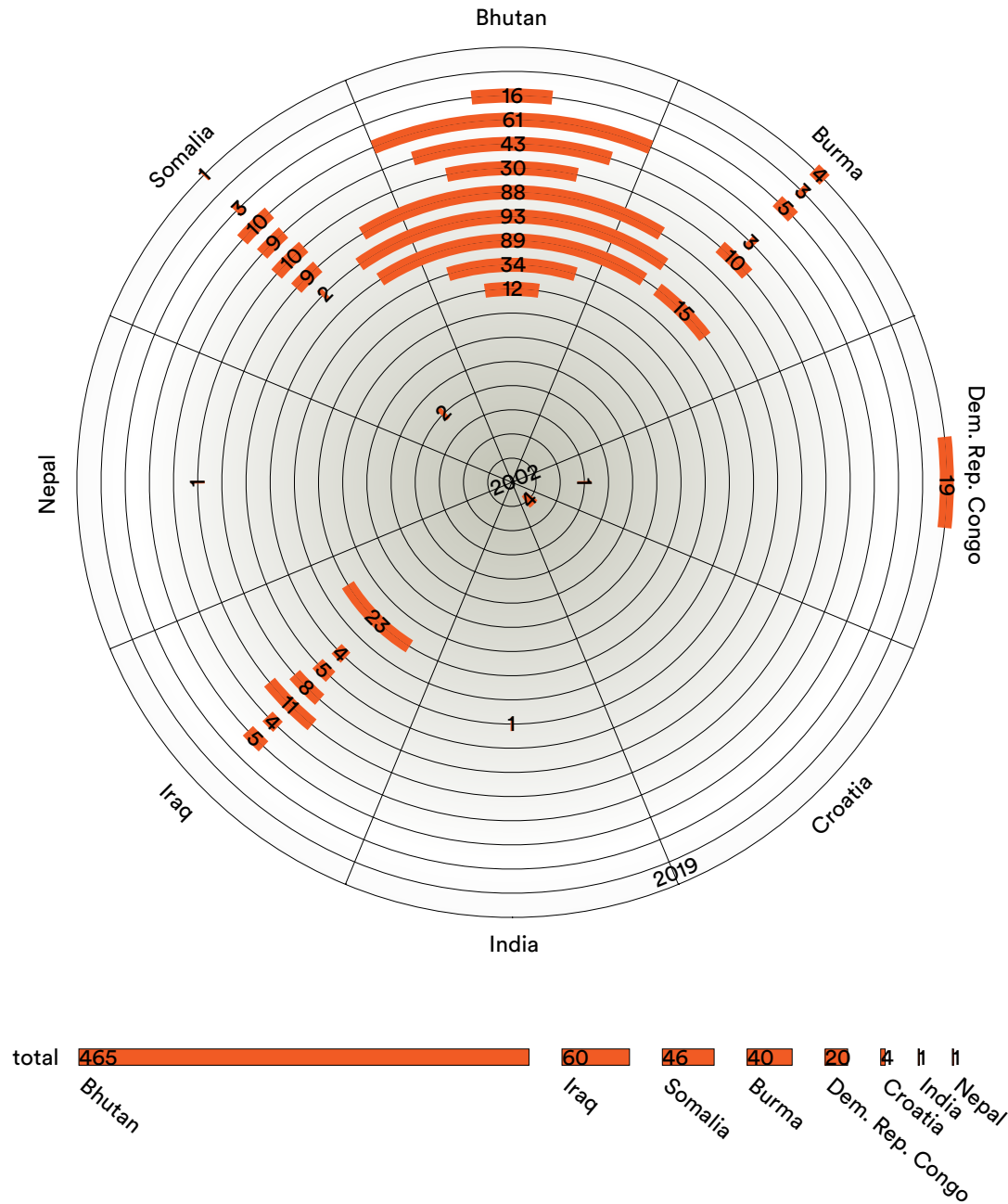

number of refugees resettled in Winooski's from 2002 to 2019, broken down by country of origin

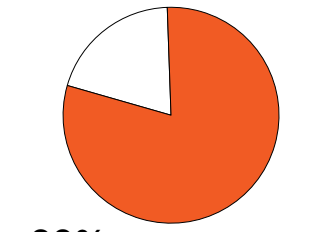

80% of respondents were accessing food assistance

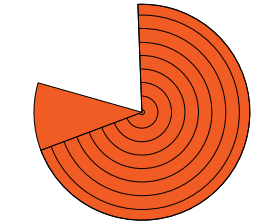

87% of those accessing food assistance did so on a weekly basis

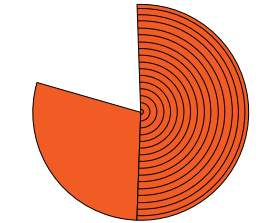

65% of those accessing food assistance have lived in the US less than 5 years

findings from a RRSC and UVM study among Chittenden County's Refugees

One of Chittenden County's major refugee resettlement neighborhoods, sits just off of Winooski's main street. In a study conducted by RRSC (Refugee Resettlement in Small Cities) along with the University of Vermont, the effects of COVID-19 were seen to be particularly impactful to the new American and Refugee population in Chittenden County.<sup>27</sup> Of the study's respondents, 80% had been receiving support from various food assistance programs, 87% of which were doing so on a weekly basis. About 65% of refugees who were accessing food assistance programs have been in the US for less than 5 years.<sup>28</sup> These statistics reflect the need for extra support during the transition time

of which refugees are adjusting to their new home, obtaining jobs, licenses, cars, and a support systems. In addition to insufficient access to food, newcomers to the country also struggle to access culturally appropriate and preferred food options. **The research suggests that food insecurity among resettled refugees negatively impacts their ability to successfully adjust to their new lives in the long-term.**<sup>27</sup>

<sup>27</sup> Bose, Pablo, Anitra Conover, and Lucas Grigri, "Refugee Communities in Vermont and Food Security in Response to COVID-19," (2021), 1.

<sup>28</sup> Bose, Conover, and Grigri, "Refugee Communities in Vermont and Food Security in Response to COVID-19," 15.

## the corner stores of chittenden county



Chick's Market, Winooski, Vermont

**“In cities and towns with a rich immigrant history, markets were many things—a family business, a community gathering place, and a purveyor of food. These markets were a source of emotional and physical nourishment, woven into the daily lives of residents. Here customers could socialize, catch up on local and national news and hear gossip from back home, speak in a native language, and purchase familiar foods.”<sup>29</sup>**

Historic New England's "More Than A Market" exhibition website



1948, Corey's Market



1928, Bellino's Market



Merola's Market



1930, Izzo's Market

In the grocery gap, the corner store thrives. Many small grocery stores are embedded within low-income neighborhoods and neighborhoods of color, particularly in urban areas, across the country.<sup>30</sup> They have been interwoven within Chittenden County's community and culture since the 1800s, providing a small selection of groceries directly within residential neighborhoods. **The corner store model offers a lot to learn in the areas of approachability, cultural connection, and social interaction.**

Historically, these stores, often immigrant owned, opened up within the ground level of the owners' residential homes, providing easy access and visibility from the street.

Some of these stores added gas pumps in the early to mid 1900s, though the form, function, and offerings varied greatly from the gas station convenience stores we see across the country today. These small stores not only provided grocery items, but valued community connection. The website for Historic New England's More Than a Market Exhibition says, "In cities and towns with a rich immigrant history, markets were many things—a family business, a community gathering place, and a purveyor of food. These markets were a source of emotional and physical nourishment, woven into the daily lives of residents. Here customers could socialize, catch up on local and national news

and hear gossip from back home, speak in a native language, and purchase familiar foods."<sup>29</sup>

Through the 1800s and 1900s, Chittenden County's corner stores provided locally grown, in season produce, dairy, and meat to supplement residents' own harvests. As years went on, the offerings became less fresh and prepared and more unhealthy and packaged.

<sup>29</sup> "Food, Community, and Family in the Markets of Burlington and Winooski, Vermont," in *More Than A Market Exhibition*, (Historic New England, 2022), <https://morethanamarket.org>.

<sup>30</sup> Raja, Samina, Changxing Ma, and Pavan Yadav, "Beyond Food Deserts: Measuring and Mapping Racial Disparities in Neighborhood Food Environments," *Journal of Planning Education and Research* 27, no. 4 (June 2008), 470.



Today, the corner store remains a valued community space. We can further break down the corner store typology into three categories: the small grocery stores offering limited food options, the ethnic markets who provide culturally-diverse goods and a cultural connection for new Americans in the area, and the convenience store attached to gas stations. In addition to offering food options, the small grocery stores and ethnic markets have become places for social interaction, to run into neighbors and catch up with the store's owner. **Its small scale, casual demeanor, and innate familiarity**

**are inherently inviting.** The More Than a Market exhibition website describes this as, **“Like community living rooms, these places offer us a place to relax, share ideas, and satisfy a universal longing for connection.”**<sup>31</sup> Though the gas station convenience store also maintains a casual welcomeness, it can sometimes lack the domestic comfort and community connection that make the other two models so meaningful.

<sup>31</sup> "Food, Community, and Family in the Markets of Burlington and Winooski, Vermont."

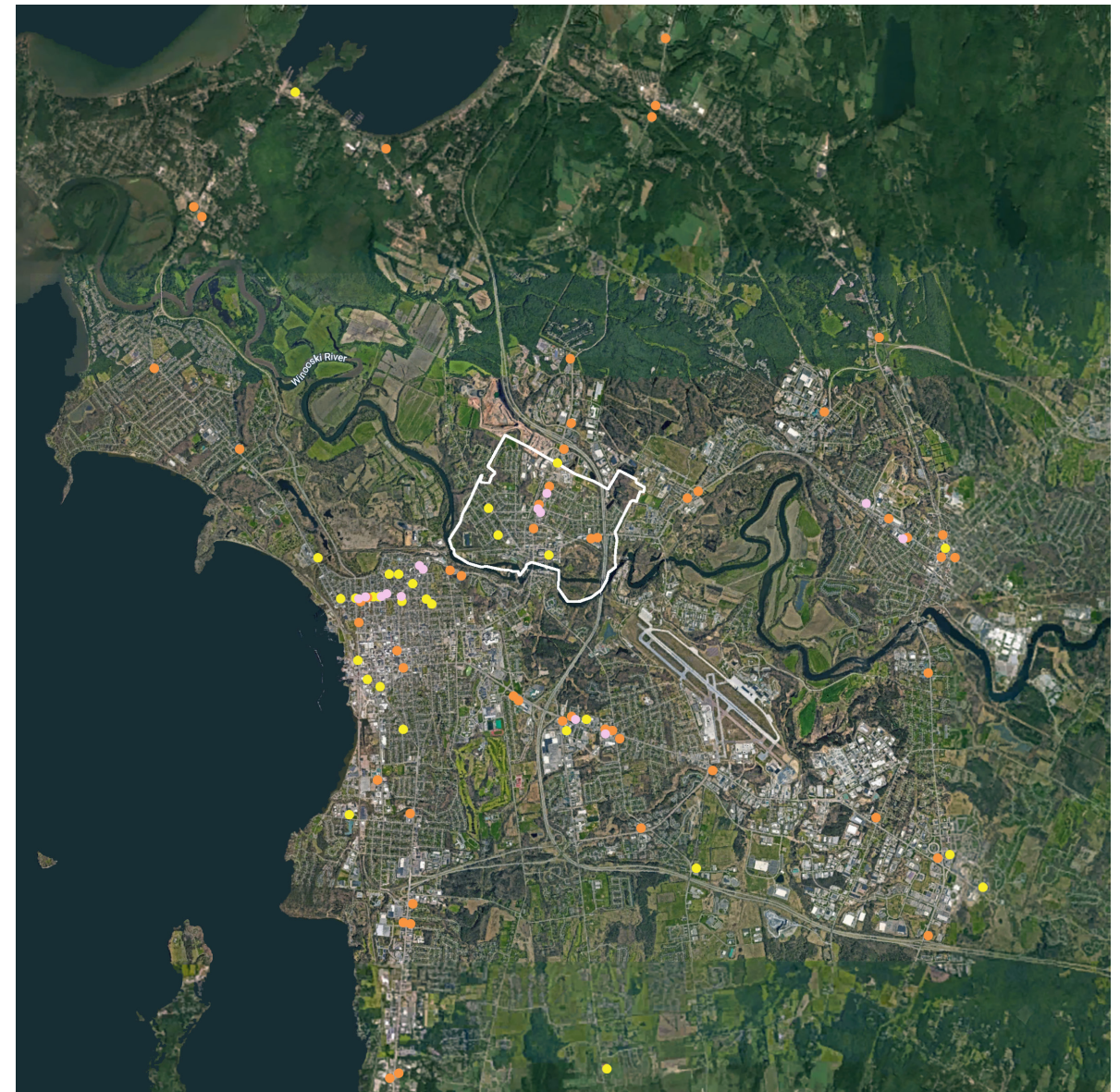

- small grocery stores
- ethnic markets
- gas station convenience stores

In this map, Winooski is outlined in white and all corner stores are indicated through various colored dots, signifying their further classification. Most of these markets appear in denser neighborhoods within Winooski and Burlington. The small grocery stores and gas station convenient stores are also more populated along major roads, while the ethnic markets remain in neighborhoods.

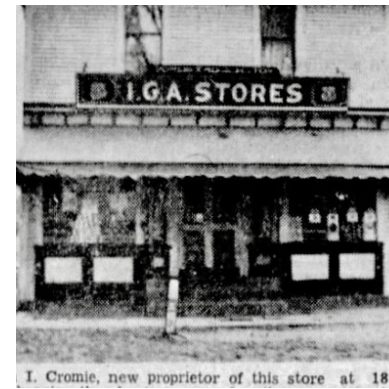

I. Cromie, new proprietor of this store at 18

the corner stores of Chittenden County

# network host structures



Momo's Market,  
Burlington, Vermont



Chick's Market,  
Winooski, Vermont



Mawuhi African Market,  
Burlington, Vermont



7 to 11 and Emmon's Market,  
Winooski, Vermont

# hub and spokes

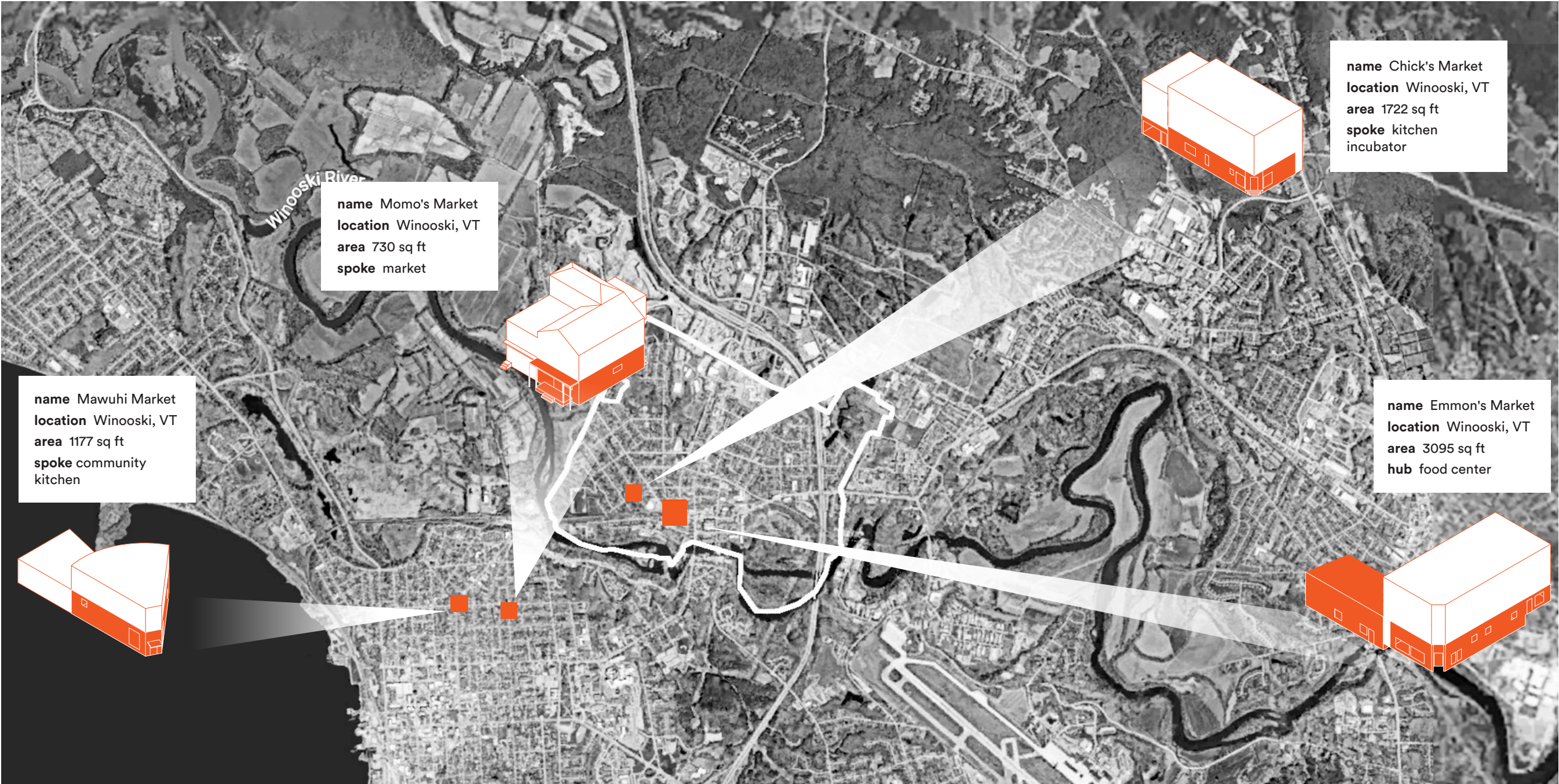

intervention area (existing retail space)
  not intervened on

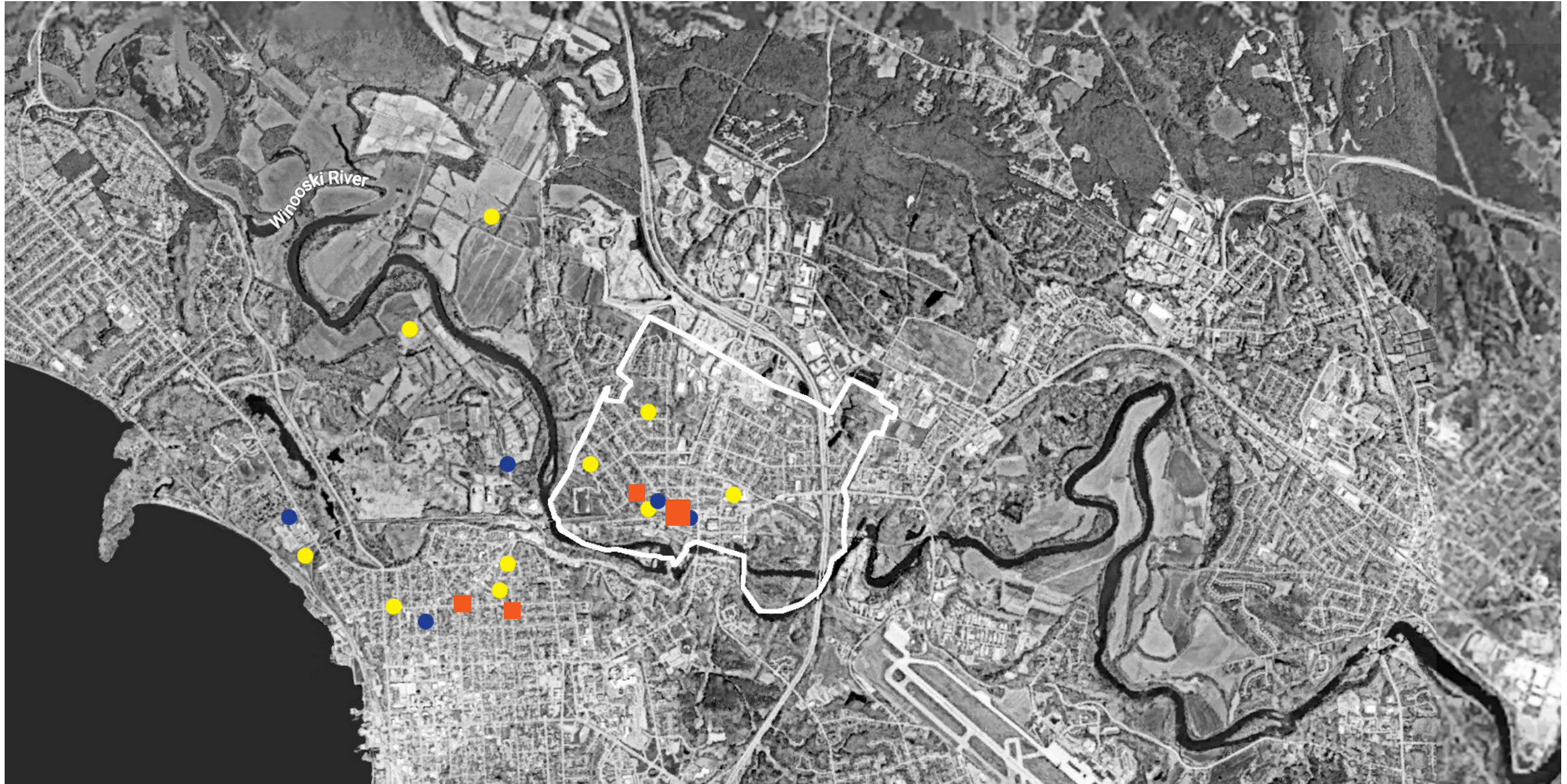

■ hub (main host structure)

■ spokes

● produce source: farming plots and community gardens

● current free food distributions and food pantries



# main host structure



35 West Allen St has been home to many corner stores, ethnic markets, and deli's throughout the 1900s and into the 2000s, shown here as 7 to 11 Market



35 West Allen St as Emmon's Market



1980 fire gutted the structure, requiring extensive structural rehabilitation



35 West Allen St as West Side Deli in 1983, post fire



Today, the attached garage is an apartment, the first floor's brick and siding is painted green, landscaping surrounds the building, and windows are unobstructed by advertisements and displays





**built** 1905  
**location** 35 W Allen St, Winooski  
**total area** 6,378 sq ft  
**construction type** brick masonry and light wood framing  
**current use** hair salon and apartments

Built in 1905, this building has been home to several corner stores, ethnic markets, and deli's throughout its lifetime, with apartment units above like most small grocers. Some of these small businesses included 7 to 11 Market, Emmon's Market, West Side Deli, and, most recently, the Good Luck Store. Though the building suffered a fire in 1980, it remains in good condition. Today, the corner retail space is home to a hair salon, with an apartment in the back of the first floor, four apartments above, and one in the since-rennovated attached garage.

**This structure's location is ideal for food access:** it is located on a corner lot just off of Main Street and the Winooski Circle, centrally located among existing important community spaces and easily walkable. For this reason, the first floor—consisting of the current retail space, apartment in the back, and apartment in the old garage—will be intervened upon. The intervention space totals 3,095 square feet, **large enough to serve as a market, kitchen incubator, community kitchen, multi-use space, and food center.** This location supports the network of food spaces throughout Winooski and Burlington as **the primary hub** in the 'hub and spokes' model.

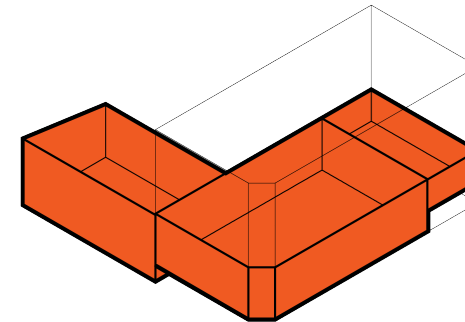
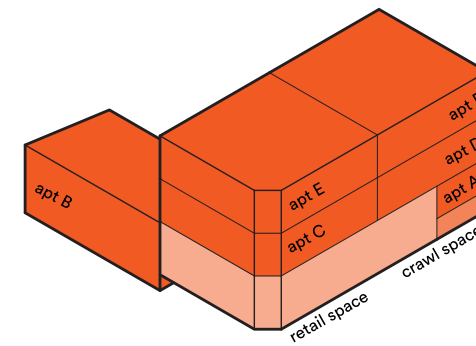
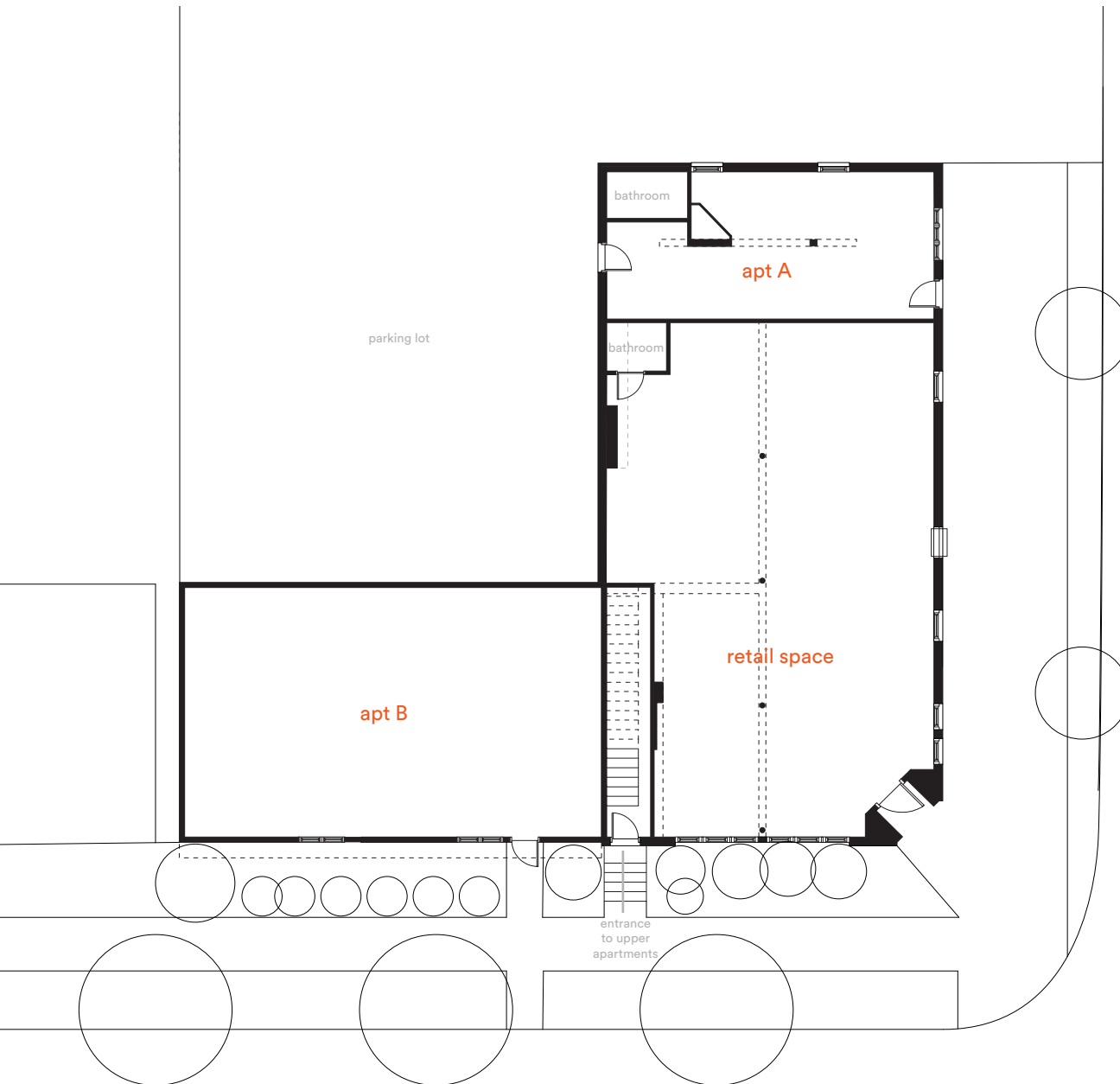

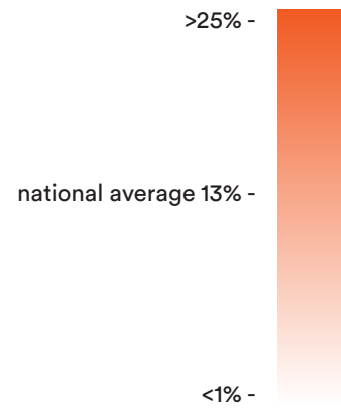
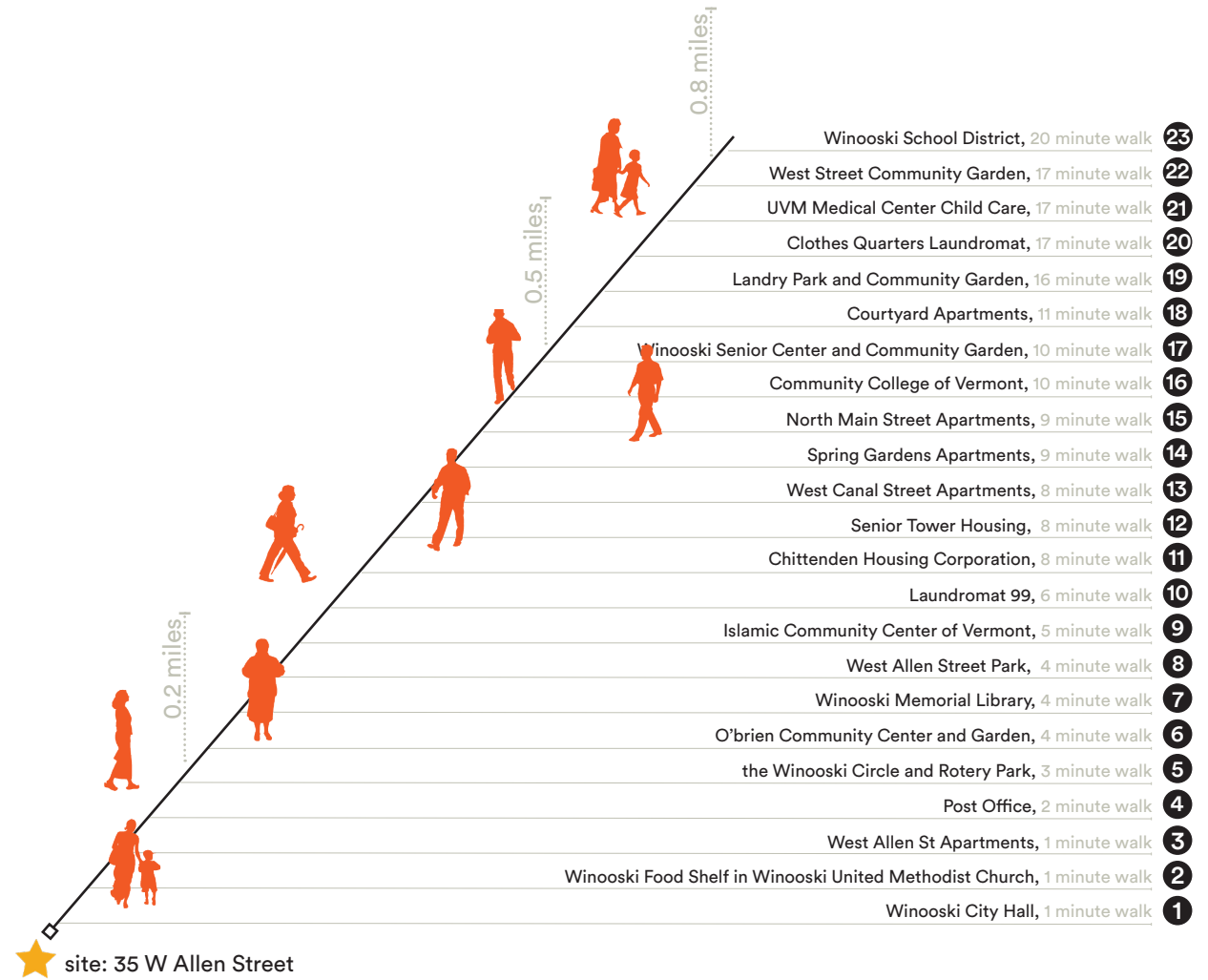
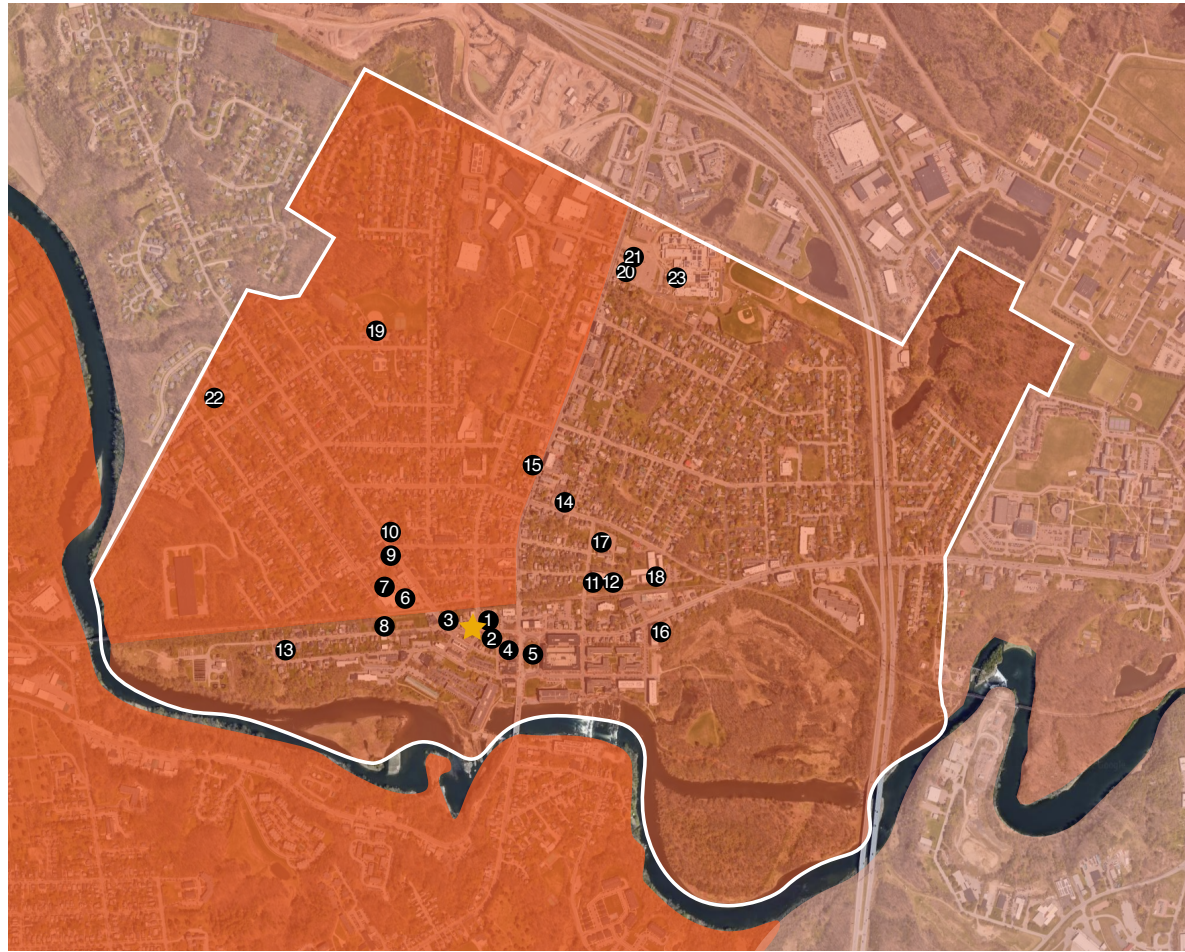

Given the inextricable link between poverty and food insecurity, the host structure's proximity to low-income neighborhoods and low-income housing is essential. The gradient overlays of this map indicate the area's poverty rate as seen in the key to the left. Low-income neighborhoods in Winooski are identified by indicating the percentage of the population who are below the poverty level, relative to income over the past 12 months. As seen in the diagram on the right, six low-income housing locations are within a 12 minute walk of the site.

In addition to housing, other commonly visited places within Winooski's community are walkable. The site is located within a 3 minute walk of the Winooski Circle, the city's downtown, 2 minutes to the post office, and 4 minutes to the community center and West Allen Street Park. Evenly dispersed around the site, this location is already along everyday routes of locals. Located across from the Winooski Food Shelf and a few blocks from the pop-up free food distributions at the community center, this site is a reasonable alternate location for free food access.



# chapter 4: food spaces

This chapter analyzes various food spaces, concluding from observational research, volunteering, interviews, programmatic precedents, and broader research into food assistance. Analyses of four different food pantries provides insight into both the strengths and weaknesses of various methods of food distribution. Looking at different models of food access, both for-profit and not-for-profit, presents alternative strategies to build upon and improve the traditional food pantry model.

# winooski food shelf

**type** pick-up pre-packed box  
**location** Winooski, VT  
**area** approx. 800 sq ft  
**number of workers** 27 consistent volunteers  
**number of people served** 50 households a week

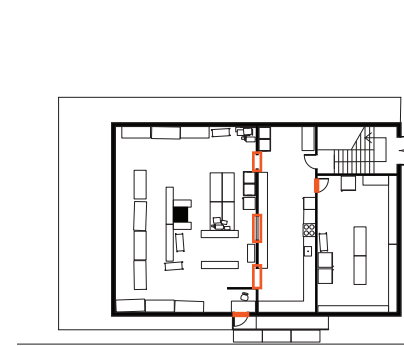
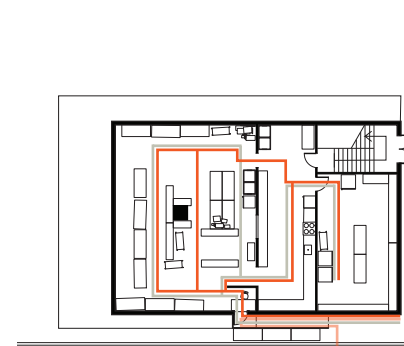
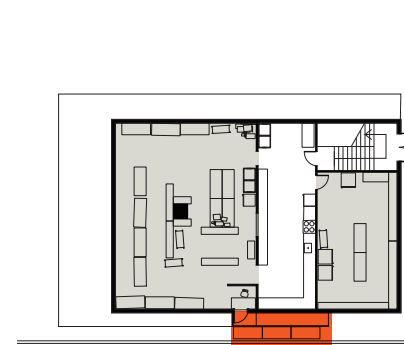

— separation      — connection

## programming

- storage** interior space is only storage, there are 5 refrigerator/freezers for meat, dairy, and produce, though most of the produce needs to be delivered on the day of distributions because it cannot be stored
- distribution zone** on the exterior ramp, users are handed pre-packed boxes, extra dry goods are displayed on folding tables on the sidewalk to take freely
- kitchen** mostly used for storage

## circulation

- users** line up on the exterior ramp, receive food, and turn around to leave (circulation is not continuous), they never enter the interior
- workers** inhabit the interior, can get crowded before and during distributions
- food** delivered through the side door by the ramp and gets stored in fridges, shelving, and on tables throughout the whole space, food is sorted into distribution allotments on folding tables

## connections and separation

users are physically separated from workers and the interior by a table that sits at the entrance (where food is distributed)

on the interior, there are some connections between rooms (open doorways and a window between the storage area and kitchen) which creates easy communication and movement between spaces

# centre street food pantry

**type** car distribution  
**location** Newton, MA  
**area** approx. 1500 sq ft  
**number of workers** approx. 20 people at distributions  
**number of people served** 276 families a week

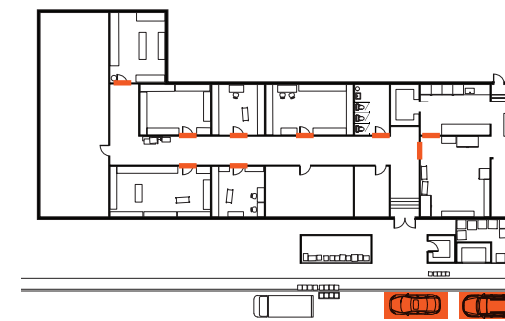
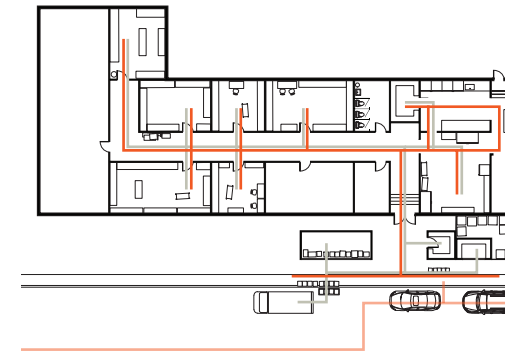
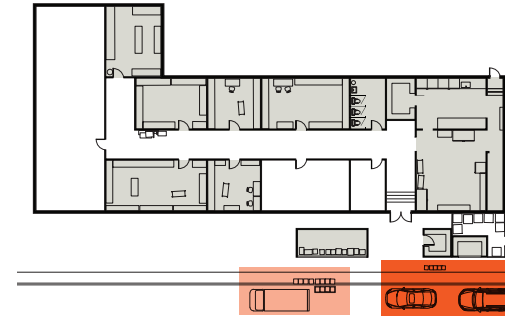

— separation — connection

## programming

- storage** interior space is mostly storage, there are 10+ refrigerator/freezers and a walk-in cold storage unit for meat, dairy, and produce
- distribution zone** cars pull up to the sidewalk where workers help users put pre-packed bags of food and toiletry items in their cars
- unloading zone** on the street, unloads food onto sidewalk
- other** some rooms are used by the church for other programs

## circulation

- users** line up around the block in their cars, leave their cars briefly to put bags in their car
- workers** inhabit the interior, a few people per room organize and sort, hallways can get crowded before and during distributions, they also work outside sorting and distributing food
- food** unloaded onto the sidewalk and stored in exterior walk-in unit or brought inside and stored in rooms, where they are sorted

## connections and separation

being in their individual cars, users are physically separated from each other and only interact with workers briefly, they do not enter the interior

on the interior, the rooms are somewhat closed off, which can make coordination and communication difficult

# intervale pop-up distributions

**type** pop-up locations

**location** Winooski and Burlington, VT

**area** approx. 600 sq ft of storage and work space, and 100 sq ft for outdoor locations

**number of workers** 2 or 3 workers at distributions, 177 volunteers farming

**number of people served** 325 households a week

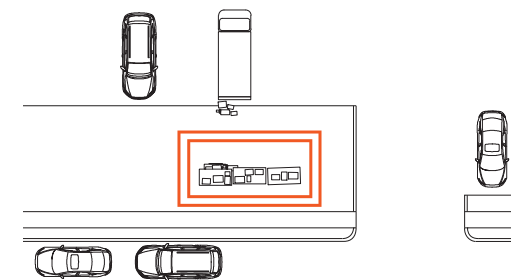
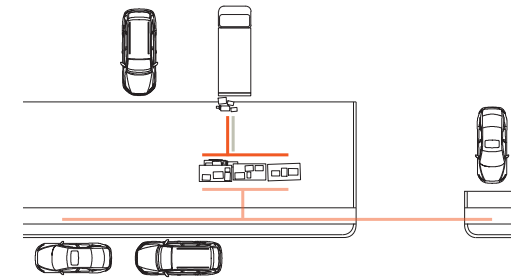
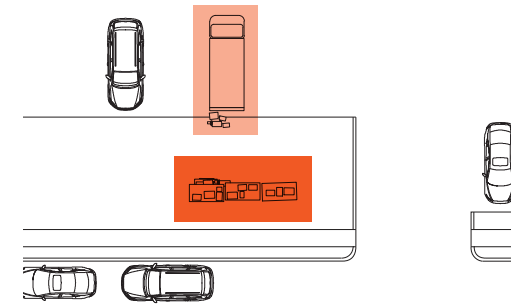

— separation      — connection

## programming

**unloading area** uses the community center parking lot to unload food from the box truck, often with pallet jacks

**distribution zone** located off a main street, it is easily identifiable, but it is also exposed to public view

**storage** dry and cold storage is located in Burlington, where food is stored and sorted after gleaning before transporting to pop-up locations

## circulation

**users** approach and gather around the folding tables freely, taking food as they please

**workers** often back away to give users space, but still interact

**food** boxes of produce unloaded from truck and placed on folding tables

## connections and separation

being outside, there is little separation between people and no separate spaces

encourages social interaction but it is also exposed and can become unorganized



# the family room

**type** browse freely

**location** Burlington, VT

**area** approx. 400 sq ft of shared storage and 100 sq ft for distributions

**number of workers** 20-30 workers for cooking, organizing, and distributing

**number of people served** 170 households a week

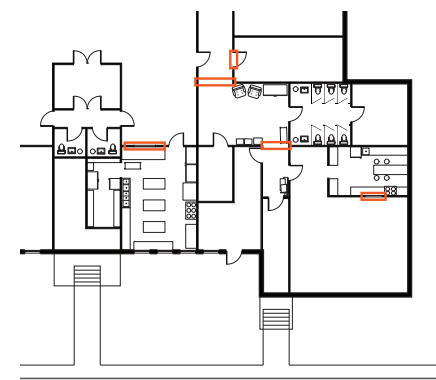
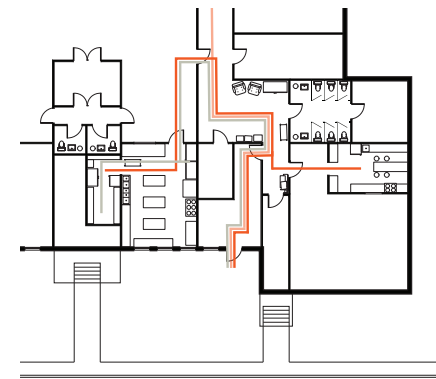
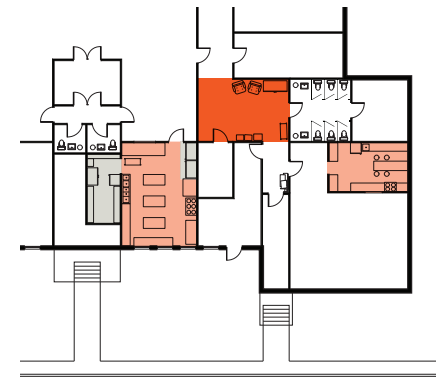

— separation — connection

## programming

**storage** limited shared storage with the whole building in a few fridges and shelves, most of food is stored in the distribution zone

**distribution zone** located in the corridor daily and occasionally outside

**kitchen** separate kitchen and shared community kitchen, used for shared cooking among workers and sometimes users

**other** rooms are used for other programs, some multi-use classrooms used for eating

## circulation

**users** enter the space and take food freely at any time or during scheduled distributions, circulation becomes overcrowded during distributions and between other events

**workers** prepare and sort food in the kitchens and distribution zone, and interact with users in the other spaces

**food** food is delivered through the front door and transported through the space to distribution zone and shared storage, the long path makes delivery inconvenient and often overcrowded

## connections and separation

the distribution zone is open and becomes a gathering place

in some instances, partial barriers (dutch doors for classrooms and windows between kitchen to playroom and community kitchen to multi-use room) control movement, specifically of children, but remain connected for visual access and communication

# limitations of the food pantry

Through my analyses, I have identified limitations to the traditional food pantry model, aspects that if addressed could better serve both users and workers.

## location + coordination

Despite the many community assistance programs in Chittenden County, and several food distribution pop-up sites, there is only one that has a permanent location in Winooski: the Winooski Food Shelf within the Winooski Methodist Church. This might not be welcoming to those of different faiths, or those who are not religious. Further, Burlington has more access to food and community assistance programs and are better served by grocery stores than those in Winooski.<sup>32</sup> For this reason, **locating a food assistance program within Winooski, and providing a more structured coordination of various food spaces, could prove beneficial to the community.**

## inefficiency in use and function

The spaces that food pantries occupy are frequently intended for other functions, often not realting to the storage or display of food, resulting in spaces that are incapable of supporting the needs of the program. Food distributions are unable to occur in these spaces, requiring complete reconfiguration of the space on food distribution days, in which tables, shelving, crates, and the food itself has to be pulled out, set up outside or in random open spaces like hallways, and later stored again. Overall, current spaces are inhibiting efficiency, which is particularly important when resources are limited.

### **Creating spaces and secondary elements**

**that are adaptable and able to function as multi-use would allow for more efficiency in the use of the space and function of the program.**

## food choice

In many food distribution methods, groceries are pre-packed or meals are pre-made. The user does not have the ability to make their own decisions, input their preferences, or participate in the preparation of their meals. Fresh food and meat is often limited, while users prefer those options over dry and canned goods. There is also a lack of culturally preferred food options, particularly impacting new Americans and refugees who are unfamiliar with offerings or how to prepare them. **Allowing users to maintain agency in food access needs to be prioritized, not only to ensure the food provided will be eaten, but also in respecting peoples' inherent need for autonomy.**

## lines + wait times

Something seen often in the traditional food pantry model is long lines. Often only open a few times a month, programs experience high demand in a short timeframe, serving hundreds of households in only a few hours. Long lines—of cars or people—often form outside. This high visibility to the public is particularly impactful on the level of dignity and comfort the clients experience. **If food distribution was offered more frequently for longer periods of time, the demand spreads out and there can be a more free flowing movement of people.**

## waste management

With any food space, garbage and recycling is expected to be plentiful. Food assistance programs have to deal with a large volume of food packaging, particularly cardboard boxes. In make-shift spaces, box breakdown seems to find homes in hallways and other random areas, largely impeding on circulation and organization of the space. There is also a large amount of food waste from leftover produce gone bad or food scraps. **Adequate space to accommodate box breakdown, composting, and storing trash and recycling bins would go a long way in increasing the functionality and organization of food assistance programs.**

## physical separation

In current food distribution methods, social interaction is also limited, thus inhibiting the client's sense of belonging and community. The program and level of interaction is guided by existing spatial conditions rather than by the needs of the client and the program as a whole. What results is a disjointed set of spaces that are not serving the overall experience of users. In many instances, spatial requirements do not allow clients to inhabit the space freely, often unable to enter at all. Physical barriers between storage space, distribution space, and rooms designated only for workers contribute to the idea that visitors are not welcome, do not have ownership in the space, and are separate from the workers. **In reframing the project to prioritize social,**

**collective engagement, food assistance spaces can offer more than just food access.**

## stigma

The societal stigma associated with food assistance directly impacts a person's experience, feelings of comfort and self-esteem. In a study on Vermont's food insecurity in April of 2020, researchers found the following conclusion: "Importantly, this research demonstrates there are still a significant number of food insecure households which, even if aware of food assistance programs, may not utilize them. Low rates of seeking assistance in our results, especially among newly food insecure households, may be partly related to the stigma associated with assistance programs."<sup>33</sup> **In designing food assistance spaces that are approachable and dignified, the user experience can be greatly improved.**

## social support systems

This same study found that "populations living outside major metropolitan areas may be more likely to utilize friends and family for support and to see government assistance programs as a 'last resort.' However, with social distancing and widespread financial challenges, such personal safety nets may be eroded, and these households may be particularly vulnerable."<sup>34</sup> While COVID mandates and social distancing are not in effect as strictly, this challenge remains particularly for resettled refugees, who are new to the area, without a US driver's

license, and separated from their support system. **Support from friends and family often comes in the form of sharing meals, presenting an opportunity to increase food security through social interactions around food.**

## increased need

During COVID-19, we saw an increase in food insecurity nationwide. Food benefits, such as SNAP benefits, school lunches, and offerings of assistance programs, increased to support households in need. However, these benefits are expiring, despite the consistent need for them. For this reason in particular, **food insecure communities would benefit from additional food spaces, offering not only free food distributions, but a variety of shared food experiences to fill the social and nutritional gaps left by COVID.**

<sup>32</sup> Bose, Conover, and Grigri, "Refugee Communities in Vermont and Food Security in Response to COVID-19," 8.

<sup>33</sup> Niles, Meredith T. et al, "The Early Food Insecurity Impacts of COVID-19," *Nutrients* 12, no. 7 (2020): 2096, 6.

<sup>34</sup> Niles et. al, "The Early Food Insecurity Impacts of COVID-19," 6.

# other food spaces



## co-ops

There is a lot to learn from food cooperatives (co-ops). **To say it succinctly, co-ops reinvest in communities. They provide food, functioning much like a typical grocery store, but they also offer opportunities for growth, sovereignty, and community engagement that food pantries and grocery stores do not.**

The principles of any cooperative are as follows:

- Voluntary and Open Membership
- Democratic Member Control
- Member Economic Participation
- Autonomy and Independence
- Education, Training, and Information
- Cooperation Among Cooperatives
- Concern for Community

Initiatives like these are a great place to look for modeling food pantries. Co-ops are owned, governed, and run by its consumers, giving autonomy and decision-making

abilities directly to the community—the user. The store itself, therefore, is culturally relevant and a reflection of the wants and needs of the people. Food is fresh, local, seasonally-specific, and culturally preferred. They often provide job and leadership opportunities, skills training, and partnerships with local farmers and producers. There are usually collective spaces offering various community events. Co-ops simultaneously offer self and mutual support: a collective, comfortable, and trusted model.

## community kitchens

**Pairing community kitchens with food pantries offers its users valued food sharing experiences that a food pantry alone is incapable of supporting.** Rather than stopping at food distribution, shared cooking and eating creates social connection, provides opportunities to learn, and instills a sense of autonomy within each individual.

There is not a strict model for a community kitchen. In fact, it is often more of a programmed name than a physical space. Like food pantries or soup kitchens, community kitchens are often located in churches, schools, or community centers, wherever a capable space already exists. They typically use commercial kitchens in which many community members can cook together. Due to the large volume being cooked, cooking tools are generous sizes and plentiful. Meals are shared in what is often a multi-use space or distributed out and taken home. Participation in these community meals are often by donation.

## teaching kitchens

Culinary education is not only useful for emerging chefs, but for everyone. Food insecure households can learn nutritional education and cooking skills to improve eating habits. Refugees who are unfamiliar with local produce or typical grocery items can learn how to prepare meals with the food available. Those who farm can learn new techniques for preparing, storing, and/or selling their produce. **Within these spaces, a wide variety of shared food experiences can happen, with or without the explicit intention of learning.**

The teaching kitchen design is structured for both individual work stations and gathering around a demonstration, making it a good example to host various shared food experiences. These kitchens often have a freestanding island enabling gathering around the central food preparation space along with multiple rows of work stations for individual skills education.<sup>35</sup> Due to this project's emphasis on creating gathering space, the design of the kitchen will prioritize gathering around a central point, rather than



having cooking appliances separated or against a wall. Additionally, teaching kitchens typically contain at least one refrigerator, stove, oven, and sink. Similar to a commercial kitchen, adequate ventilation is needed.

**In order to accommodate varied uses, such as culinary job skills training, cooking and nutrition education, unprogrammed collective cooking opportunities, and local food startups, elements within the space should be able to adapt and physically modify.** For instance, food-prep surfaces can be separated for culinary education and brought together for collective cooking.

When thinking of the user's intended uses for the space, cultural relevance is another important consideration. Not only should the kitchen be able to accommodate various levels of skills, the design should account for preferences. A comfortable kitchen environment for users is one able to accommodate a variety of cooking techniques and dining practices in which food preparation and consumption of preferred meals is possible and encouraged. **For instance, adaptability to accommodate varied heights for standing, sitting on chairs, and sitting on the floor, will allow for people to use the space in varied ways based on preference or ability requirements.**

<sup>35</sup> Tanyeri, Dana, "Functional by Design: Teaching Kitchens," (*Foodservice Equipment & Supplies*, 2018), <https://fesmag.com/topics/trends/16027-functional-by-design-teaching-kitchens>.



### the corner store

As discussed earlier, the corner store has tried its best to fulfill the need for a grocery store; however, their small scale and lack of fresh, healthy food options are not fully able to support the local food system. They nearly provide an indoor public space, but fall short in spatial requirements and the need to purchase something. Though they often have overall cheaper prices, their specialty offerings, such as international items, cost more. Despite many corner stores, residents

are still without adequate access to healthy and fresh food.

Nevertheless, **the corner store offers many architectural elements that create a universally welcoming environment, particularly relating to the relationship between the interior and exterior.** Through an analysis of existing corner stores, various components (diagrammed on the right) identify ways in which they become approachable, all of which make it easy to identify and access.

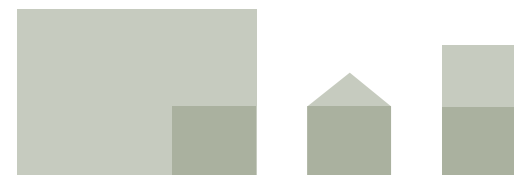

### scale

the scale of the store's facade and entrance remains uniform among various buildings despite differing overall in scale and form

this scale is familiar and approachable in its similarity to domestic entrances and relativity to the human scale



### location within neighborhood

often placed within existing residential buildings, the location is within residential neighborhoods and, therefore, walkable and easily accessible to residents

being within the neighborhood, the building already belongs to the community



### threshold translucency

a balance between solid, opaque form and open or translucent voids, both in windows, doors, and visual obstructions such as awnings, posters, and food display

offers a level of privacy from the inside without isolating the interior

enough visibility from the exterior to the interior provides comfort associated with glancing inside before entering



### proximity to the sidewalk

the building envelopes are close to the sidewalk and street, creating an easy transition from interior to exterior both in physical accessibility and comfort in crossing the threshold

the closeness of people walking by catches the eye of those walking by and invites them inside



## ethnic markets

The ethnic corner store model, often immigrant owned, sells food options from various countries, and with that, more variety in culturally preferred food options. The connection to one's homeland offers a strong sense of community for the new American community. It is a place to access preferred foods, fresh and packaged, but also to catch up on news from their homeland, speak their native languages, and socialize.

However, as discussed in chapter 1, international food options are often sourced from such lengths that the quality is poor or the cost is greater than what is offered at full service grocery chains. Their small scales mean they often do not meet the quantity required for wholesalers to distribute to them, requiring owners to travel to larger cities like Boston and New York City to source more specific culturally preferred

foods, driving up prices. What is offered, particularly what is fresh, is limited. Given that the many corner stores in Chittenden County operate independently, they are each separately experiencing this. However, if the series of corner stores connected as a network, they could collectively be able to meet wholesale quantities for distributors to deliver at a more reasonable price. **Additionally, if the network functioned as a regional food system, local farmers and producers can respond to preferences of the consumer and produce more of the types of food that locals want. Less food would have to come in from farther away, which would be better for the environment and the local economy. Locals would be able to access the foods they want and are familiar with at more affordable prices, higher quantity, and of better quality.**



# conclusion

Destigmatizing the food pantry through a sense of dignity, pride, and inclusion is essential in creating a place of belonging within the community. Turning away from the traditional charity archetype of food access and towards the examples of other food spaces discussed in this chapter is a necessary approach in combating the embedded stigma. This chapter not only identified ways in which food spaces can function better and be more capable of supporting food assistance, but also ways in which spaces can provide autonomy, prioritize social interaction, and improve the overall user experience.

Given that the majority of those seeking assistance are still relatively new to the US, my intention is to foster a sense of collectivity

and community through communal eating and cooking, drawing from co-ops, community kitchens, and teaching kitchens, as well as that which is inherent to the corner store and ethnic markets. In lieu of support from family and friends who might not be local, this space can function both as a space for food access and community support for the entire Winooski population. Additionally, it can offer culinary and nutritional education classes, cooking demonstrations, a kitchen incubator to jumpstart small food businesses and sell their products in the market, opportunities to grow and process food as a community, and, in general, gathering space to connect with neighbors. This kind of space creates deeper community resilience from the individual scale.

**chapter 5:**  
**architectural**  
**precedents**



# SDA Campclar: Food Distribution Center

**type** programmatic precedent  
**client** Cáritas Diocesana and the church of Campclar  
**location** Tarragona, Spain  
**architects** NUA Arquitectures  
**year** 2014  
**area** 880 sq ft

SDA Campclar food distribution center was designed and built in 3 months with limited financial resources and square footage. Its successful application of efficient architecture made the most out of the resources available without negatively impacting the experience of the space. Throughout the design, the architects considered material cost, time-efficient fabrication, function, beauty, vernacular architecture, easy navigation, truck access, security, natural light, and social gathering.

Within tight square footage, the architects created three spaces: a storage room, service space, and distribution zone. The permeability of the structure, both in the exterior facade and the interior “walls”, delineates space without cutting off visual connection or natural light, balancing the thin line between private and inviting. The storage area remains cleanly tucked away without creating physical separation or hierarchy between volunteer space and user space. It also contributes to an easy understanding and clear navigation of the overall space.

Responding to the clients’ requirement for a sense of belonging within the community, the architects contextualized the structure within its neighborhood through its brickwork, pentagon-shaped facade, and its long rectangular floor plan. This vernacular allows for the center to blend within the community, and become part of a whole. The overall result is an approachable, comfortable space.

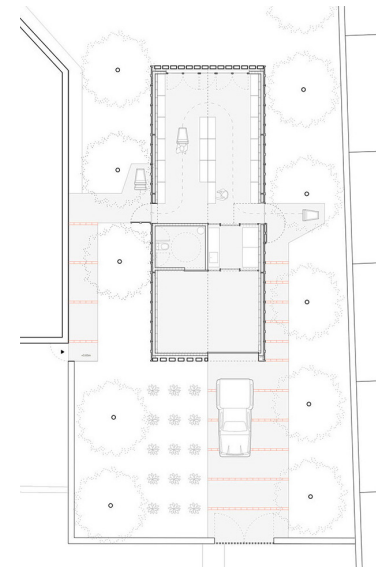
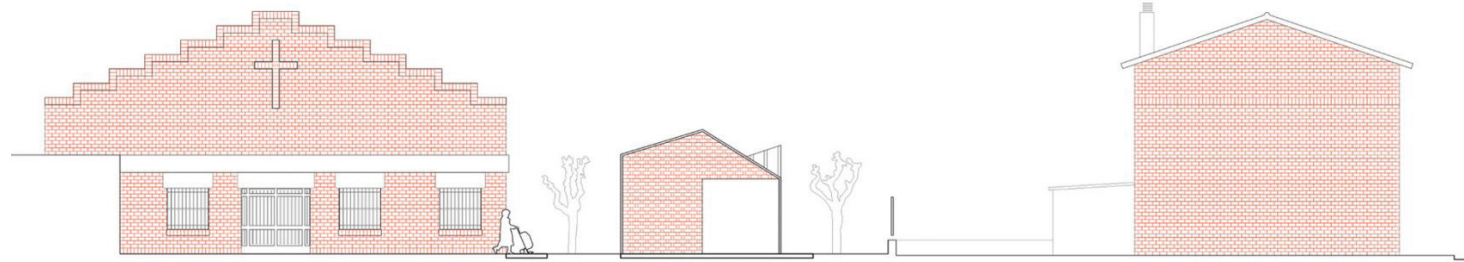

# Refettorio Gastromotiva Cafeteria

**type** theoretical and programmatic precedent

**client** Gastromotiva and Food for Soul

**location** Rio De Janeiro, Brazil

**architects** METRO Arquitetos Associados

**year** 2016

**area** 4,844 sq ft

This cafeteria serves both as a restaurant serving lunch during the day, and offering free dinner to those who are eligible at night. The building sits on the edge of a small square with a lot of foot traffic. Large portions of the exterior facade pivot, opening up to the street and square with the intention to connect people within public spaces and the community as a whole.

The structure is a single rectangular volume with openings to the road, square, and between interior levels and spaces. A long kitchen is in the center of the building, with an open view within. The building's facade is translucent polycarbonate panels, intended to feel welcome and accessible to all, while also allowing light to pass through in both directions, natural light enters during the day, and at night it is like a lantern in the city, welcoming people in. Interior materials are common to the area but modest and simple aesthetic. The project offers food access to the whole community with dignity and beauty.

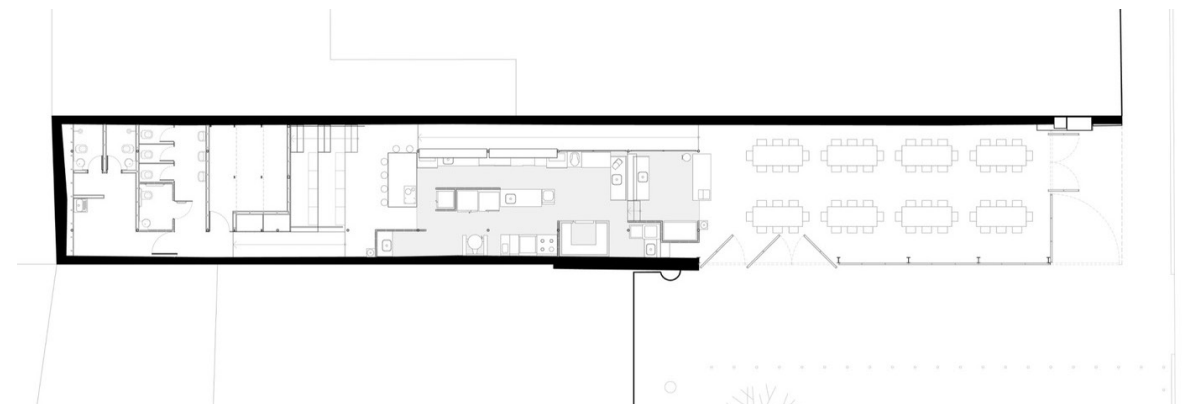
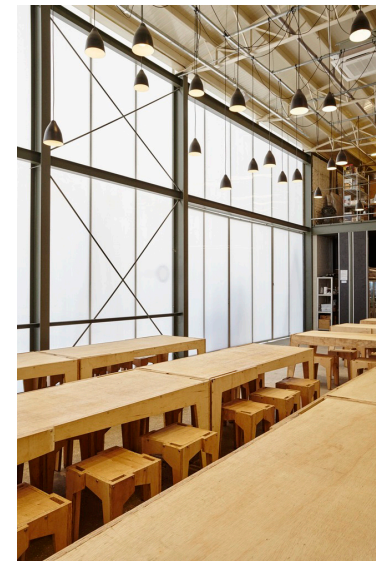

# Social Furniture

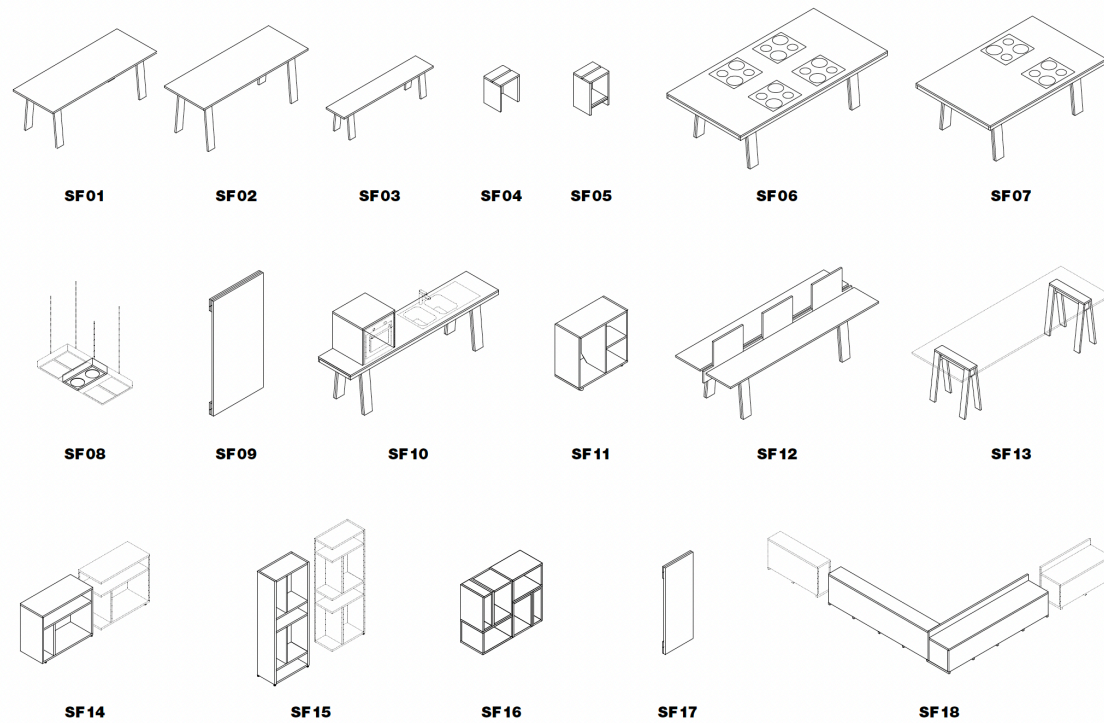

**type** theoretical and programmatic precedent  
**client** Caritas (NGO) and "Places for People" Austrian Pavilion, Venice Biennale of Architecture  
**location** Vienna, Austria  
**architects** EOOS  
**year** 2016

Social furniture is a series of 12 furniture designs implemented within an old office building converted into refugee housing. In response to the building's lack of kitchens and community spaces, the furniture encourages collective living, learning, cooking, and working. Each furniture element is meant for communal uses, for instance a table with central cooktops, bench seating, large dining tables, or a 6 person computer table. Many elements are able to accommodate appliances and tools: refrigerators, microwaves, sinks, vents, cooktops, or kitchen tools.

A design manual details the simple construction of each piece, only requiring a circular saw and power drill, to allow for a collective self-building process. Not only does this bring people together, but it provides each individual with a sense of agency and ownership over the space. The material is cost efficient, reliable and strong, with a durable, waterproof yellow surface, which beyond branding provides strong branding and visual recognition. Simple core elements make up each piece and are easy to re-assemble and combine in different ways.

While the project was intended for refugee aid projects, it can be further applied at larger scales for varied needs within any existing site.



# Kitchen-Hub

**type** programmatic precedent  
**client** Über den Tellerrand,  
(refugee support initiative)  
**location** Schöneberg, Berlin,  
Germany  
**architects** CoCoon Studio and  
Technische Universität Berlin  
**year** 2016  
**area** approx. 450-600 sq ft

This project was designed and built during the design studio Refugee City: Cooking with Refugees. They designed and built modular furniture elements that create space for coexistence and shared food experiences between refugee and non-refugee community members, in which users can actively shape their environment.

The modularity of this project accommodates a variety of uses within a small space, while also providing agency and autonomy to the community. The elements are easy to store and to assemble. They can stand alone or together at different heights.

The host structure for this project, an abandoned storefront, provided one small room located on the first floor at the corner of the building. The site's largely transparent facade creates a high level of visual access from the exterior. Being able to see the interior space upon crossing the entrance's threshold is inviting and comfortable, but it creates a lack of privacy from the interior. This level of transparency is not ideal for facilitating feelings of comfort and safety on the interior.

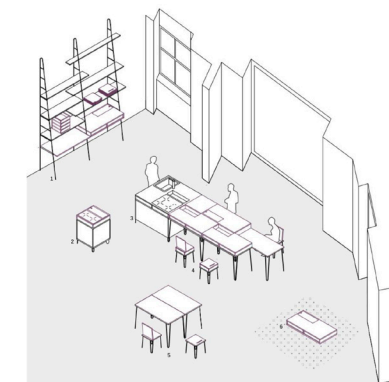

# Säynätsalo Town Hall



**type** theoretical precedent  
**client** Säynätsalo Municipality  
**location** Säynätsalo, Finland  
**architects** Alvar Aalto  
**year** 1960  
**area** 18298 sq ft

Alvar Aalto designed the Säynätsalo town hall for a small municipality in Finland, with the intention to function as a local center. In this project, Aalto managed to balance levels of intimacy, comfort, and belonging, challenged by instances of monumental scale. For instance, Aalto designed a 55 foot tall ceiling in the council chamber.

The central courtyard uniquely sits one story above the surrounding landscape. From within the courtyard, the facades of the library and office spaces seem to be just one story, but from outside of the courtyard, the elevated landscape makes the building appear taller. Feelings of comfort in the approachable, seemingly smaller scaled facade creates a welcoming courtyard, a well-used public space within the community. The lobby entrance and window-lined corridor envelope the courtyard, creating a permeable wall with visual connection to the interior passageway, thus inviting one inside.

Aalto's use of light, nature, and natural, regionally-specific materials is also noteworthy in creating a calm, comforting, and familiar environment.

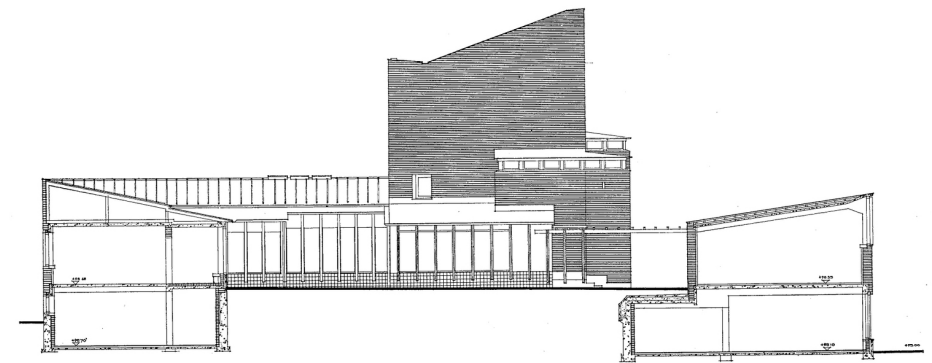
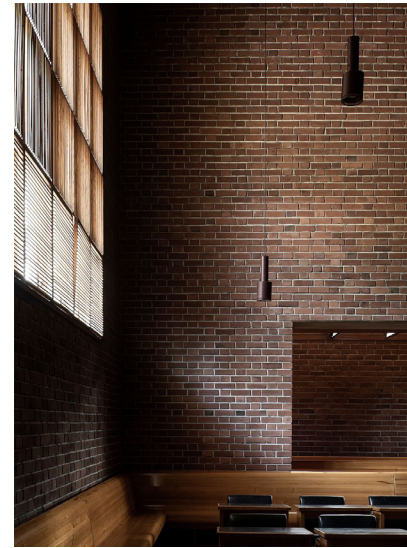

# Nest We Grow

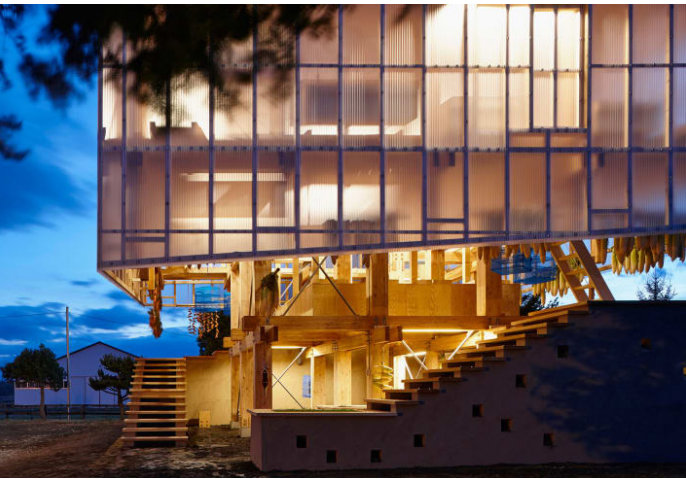

**type** programmatic and theoretical precedent  
**client** LIXIL International Design Build Competition  
**location** Hokkaido, Japan  
**architects** Kengo Kuma and Associates  
**year** 2014  
**area** 915 sq ft

Kengo Kuma and a group of UC Berkeley graduate students designed an open public structure to bring the community together to visually and physically enjoy food. The verticality of the heavy timber structure calls to the larch forests of Japan in which food is hung to grow and dry. Similarly, food plays a main character in the elevations of Nest We Grow. The framework surrounds a central gathering point with a kitchen and dining space on the ground level. Between beams, there is visual access to the space, food, and inhabitants from all interior spaces and partially from the exterior.

The structure was informed by the life cycle of food—growing, harvesting, storing, cooking, eating, and composting—and engages the local community in maintaining this cycle. The building was sustainably designed to allow natural light, facilitate air movement, block winter wind, regulate heat, and harvest rainwater and snow to accommodate growing, processing, and storing food and a comfortable environment year round. The openness of the facade is adaptable to become more enclosed in winter months and open in warmer seasons.

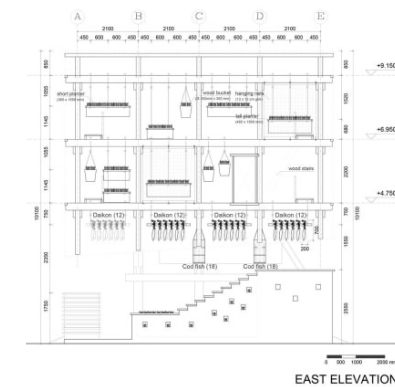

**chapter 6:**  
**design**  
**principles**

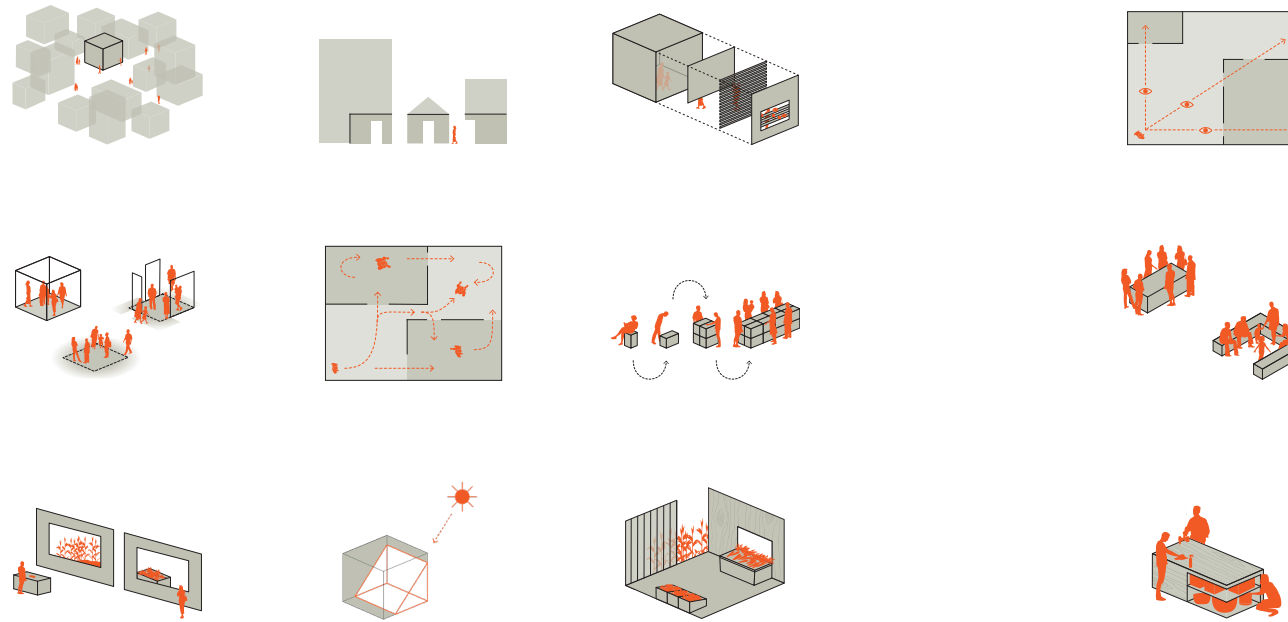

**Concluding from different methods of analysis and research, a series of principles were developed to guide the design of food assistance spaces.** The topics analyzed include: current food distribution methods, the corner store and other food spaces, architectural precedents, and research in design's effect on psychological comfort and wellbeing. **The design principles respond to three identified needs within Winooski: the limitations of the food pantry, the refugee population's vulnerability to food insecurity, and the lack of indoor public space.** Divided into four categories—exterior, interior, secondary elements, and character—the principles encompass the full scale of the physical space. Overarching through all

categories, these principles address visual accessibility, physical accessibility, autonomy in space, and efficient design. The principles respond to the limited resources available to food assistance programs, simultaneously creating approaches that prioritize users and can be realistically implemented. Throughout the design principles, there is an emphasis on psychological security, both in the feeling of safety within space and in the reliability of a food source. Further, the principles outline ways in which physical space can encourage social interaction and collective practices surrounding food, using food to fulfill both a nutritional need and a social one.



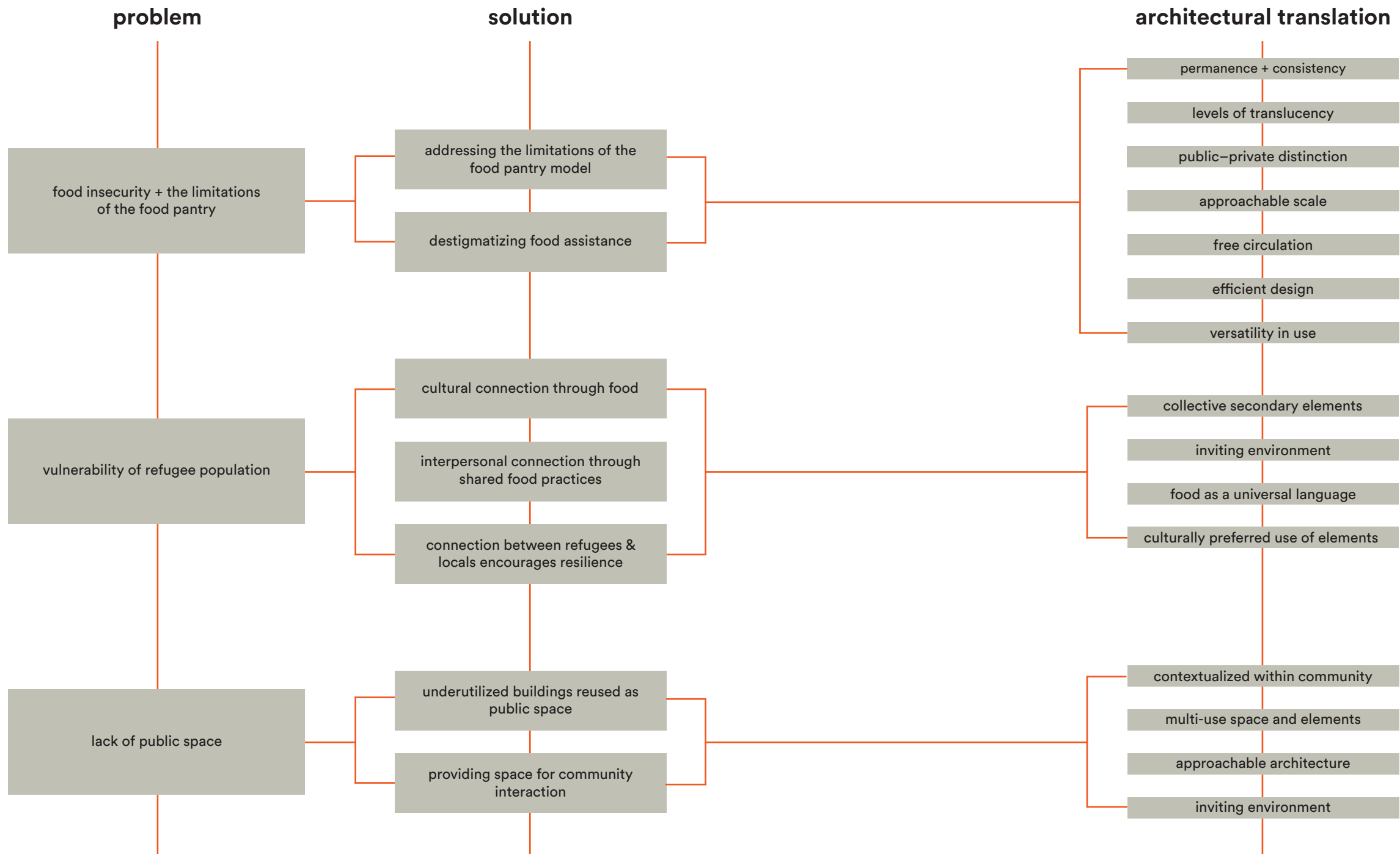

# exterior

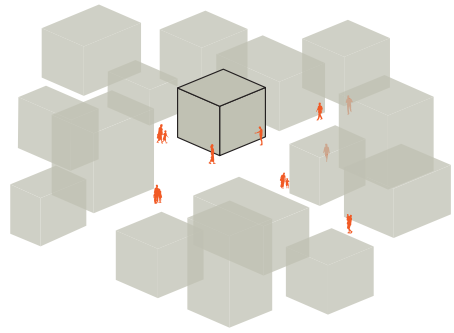

## contextualized within community

Reusing an existing structure within the community's built environment not only makes it easily accessible, but inherently welcoming.



## domestic scale

Regardless of the building size, the size of its entrance can refine or heighten the overall perceived scale and ensure that the entrance is easy to identify. The scale of a domestic entrance is comfortable to approach in its proportionality to the human dimension.

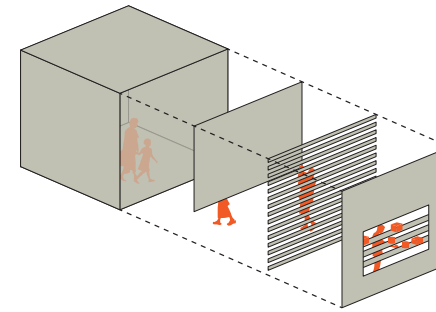

## boundary translucency

Partial visual connection between the exterior and interior—through translucent materials, strategically placed windows, semi-permeable screens, or secondary elements as a visual obstructor—displays the function and services of the space and invites users in. The ability to evaluate the interior before entering increases comfort in crossing the threshold, but a level of discretion remains.

# interior

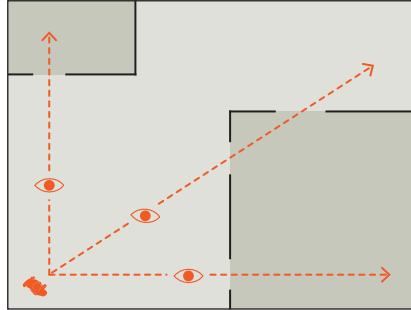

## visual accessibility

Having visual access to all spaces—through permeable boundaries and spatial organization that prioritize unobstructed line of sight—provides visitors with a sense of autonomy over their movements, an easy understanding of the space as a whole, and visually connects people and food.

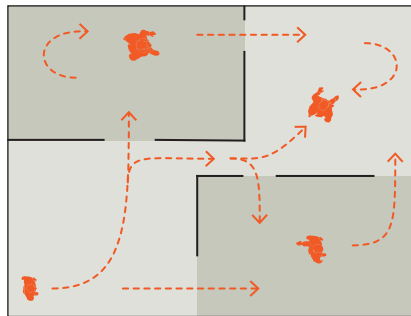

## free circulation

A permeable spatial organization with clear access points creates easy navigation paths across spaces in which everyone has equal physical access. The user can inhabit these spaces freely, with autonomy over their own movements and interactions.

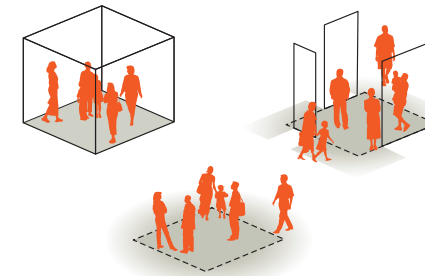

## flexible containers

Adaptable spatial boundaries modify the amount of visual, physical, and acoustic connection between spaces, allowing for flexibility in the public–private distinction. This variability, in which some are open and collective while others are discrete and contained, encourages multiplicity of use.

# secondary elements

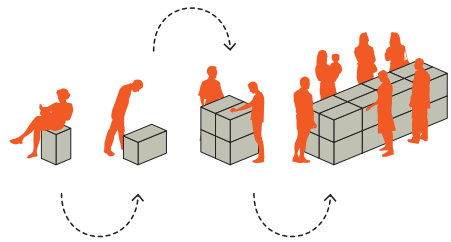

## adaptable modularity

Flexible secondary elements allow multiple uses to happen within the same space, maximizing square footage and the variety of programs offered. The ability for users to have physical control over the configuration of these objects instills a sense of agency and ownership.

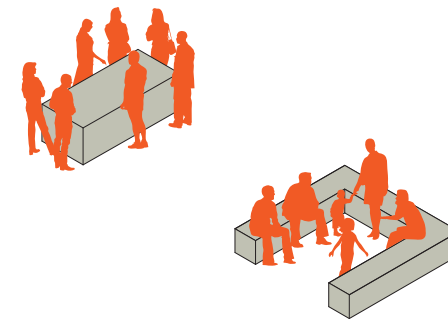

## collective furniture

Secondary elements can encourage interaction and communal engagement either through creating a central point to gather around or a boundary that surrounds and physically brings people together.

# character

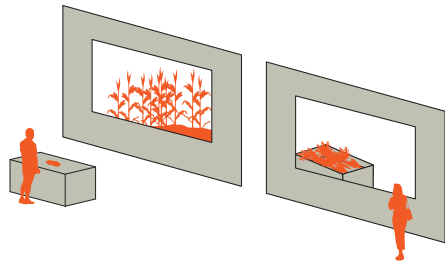

## visual connection to food

The overall design should prioritize visual connection to food: growing, preparing, and accessing. This serves both as a universal signifier that food can be accessed in this space as well as instilling a sense of security in the ability to have a consistent food source.

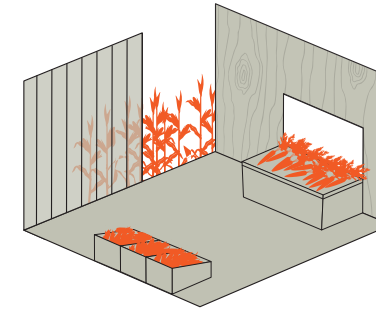

## materiality

The material selection should not only be practical, but also dignified. Humble materials contribute to a welcoming environment, while a refined selection of simple materials provides an even backdrop that prioritizes visual access to food and growing. Food safe materials, such as stainless steel or finished wood, accommodate food-focused activities.

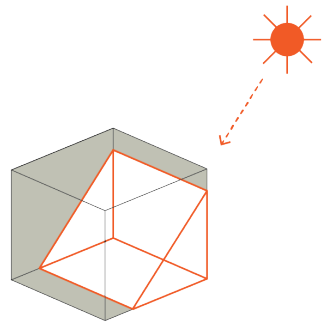

## natural daylighting

Daylighting through openings or translucent materials allows food to grow in the space. Natural lighting is an energy efficient approach in limiting the use of artificial light fixtures and heating. Further, it contributes to a dignified aesthetic, counteracting the feeling of isolation in private spaces.

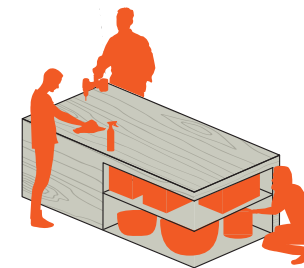

## efficient construction

Reusing existing spaces is a sustainable approach that reduces the amount of new material and construction time. Cost efficient, easily-available materials and limited, simple on-site fabrication can compensate for limited resources. Durable materials that are easy to clean, keep organized, and maintain will extend the lifetime of the design once installed.

# chapter 7: variable design elements



While many design decisions for this project were guided by prototypical elements intended to be replicable, there were many variable design elements that were specific to this host structure and its existing conditions.

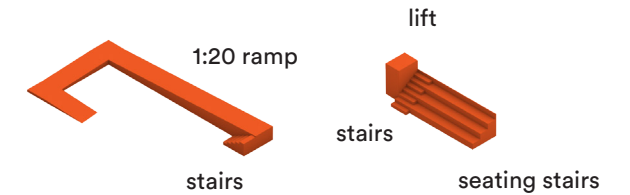
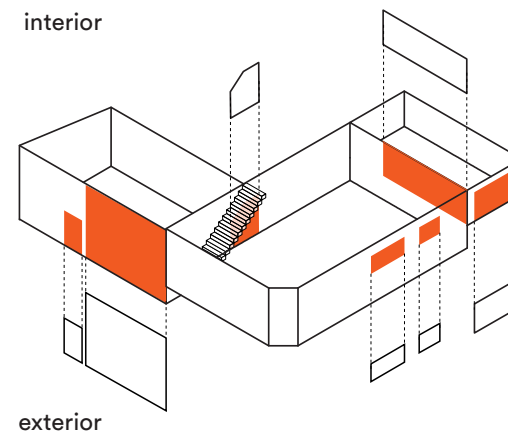
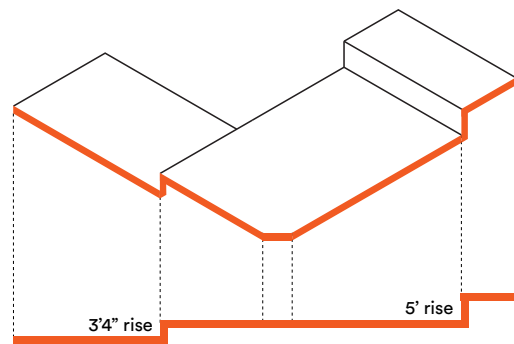
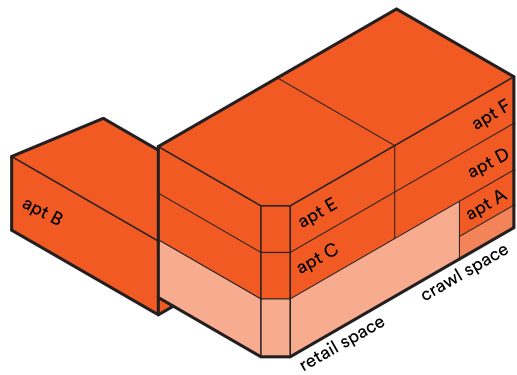

### existing use

The intervention area spans three separate sections of the building, including the corner retail space, back apartment (apt A), and attached apartment to the left (apt B). Before intervening, the structure had no interior thresholds between these spaces.

### level changes

Though all on the ground level, the sloped topography creates level changes between these three spaces. From the retail space, there is a 3'4" drop to the apt B and a 5' rise to apt A.

### providing connections

The first step in the design process was to provide connections between these spaces. The back wall between the retail space and apt A was opened up as well as between the retail space and apartment B, going under the stairs that lead to the upper apartment units. On the facade, connections provide visual access and additional points of entry.

### bridging the gaps

To bridge the level changes between these spaces, a ramp and stairs were added to address the 3'4" rise while stairs, a lift, and seating stairs address the 5' rise.



**chapter 8:**  
**prototypical**  
**design elements**

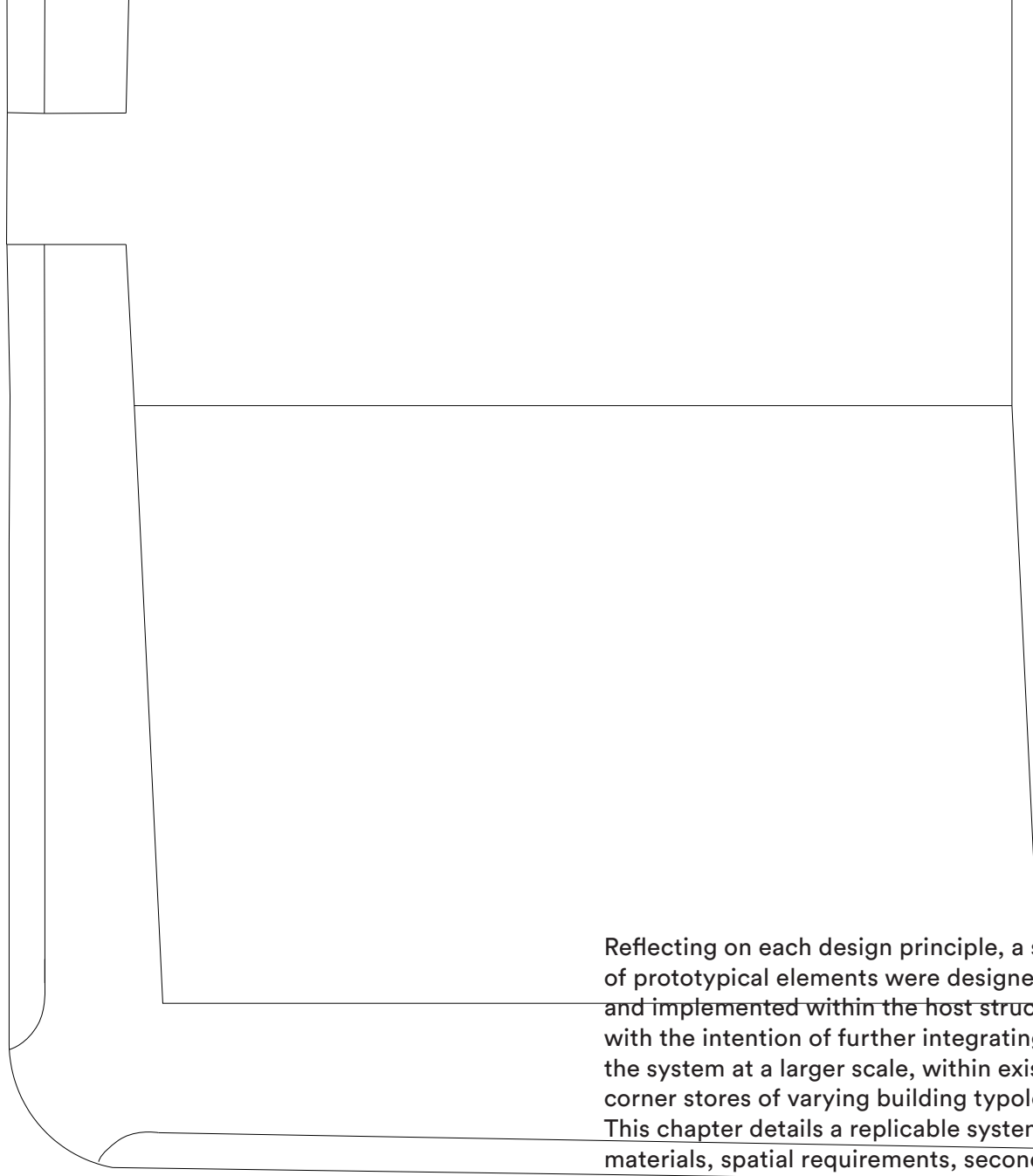
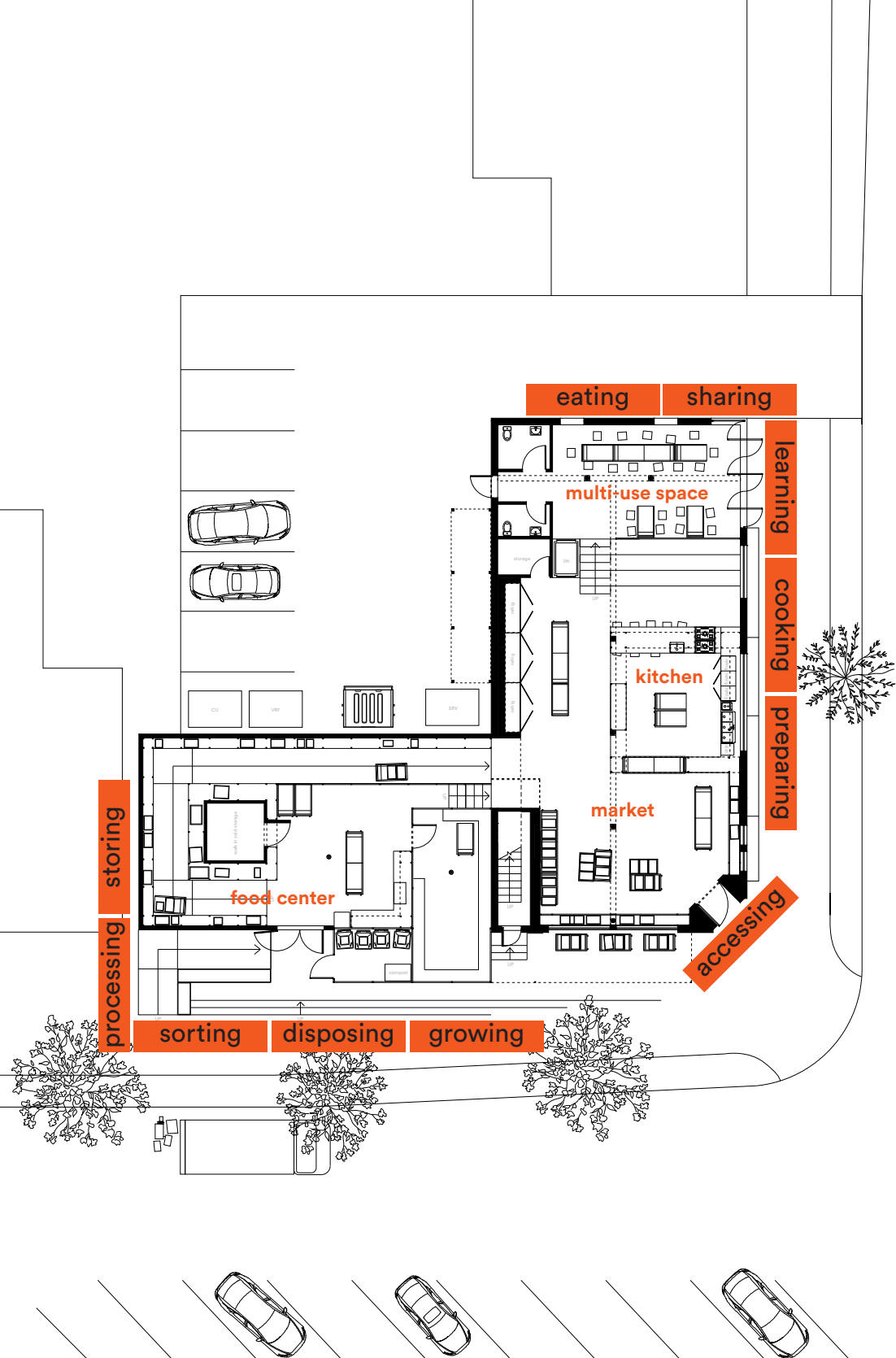

Reflecting on each design principle, a series of prototypical elements were designed and implemented within the host structure, with the intention of further integrating the system at a larger scale, within existing corner stores of varying building typologies. This chapter details a replicable system of materials, spatial requirements, secondary elements, and various configurations of both elements and the space as a whole. Together, they create a space that hosts the full scope of the lifecycle of food, from growing to eating to disposing, as seen in the diagram on the left.

# material selection



The material selection is humble and refined, creating a comfortable, dignified environment that serves as an even backdrop for food. Materials were chosen based on durability, availability, cost efficiency, and ease of construction. The replication of these materials throughout the network, particularly the orange polycarbonate, becomes an easily identifiable branding element.

# food center

**program** storage, processing, growing, food distribution

**capacity** 4 (300 sq ft/person)

**area** 1200 sq ft

**public-private distinction** public, visual access to food growing from exterior and other interior spaces

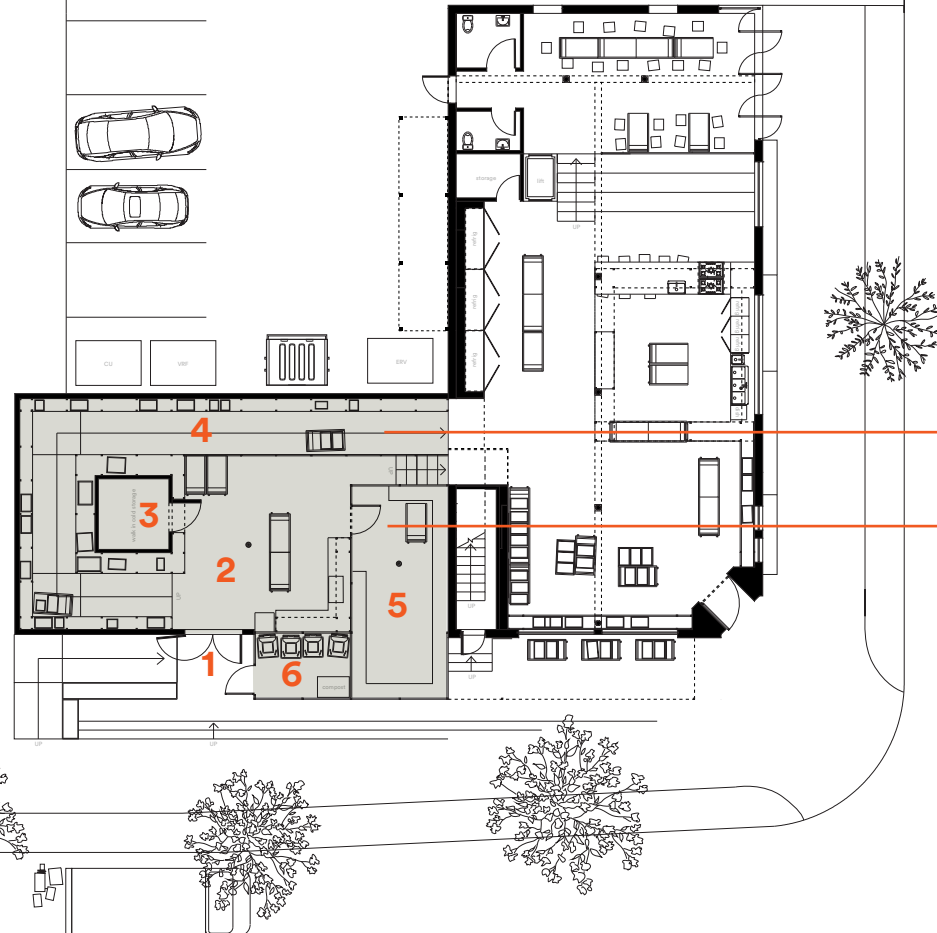

ramp + shelving system

greenhouse

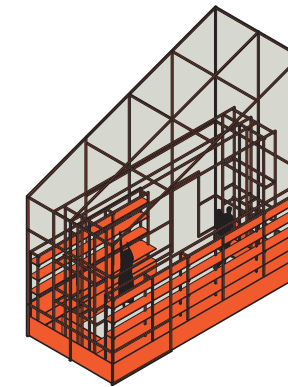
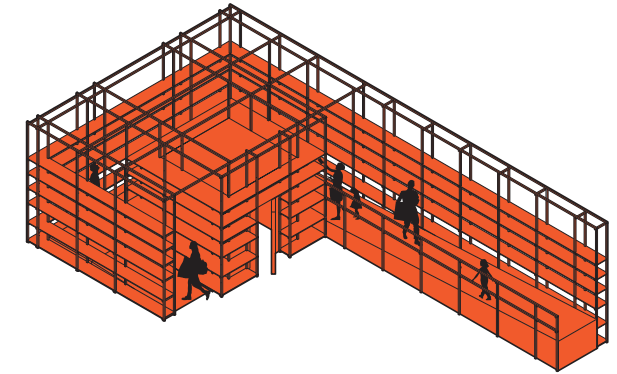

- 1 service entrance**  
as a secondary point of entry, less emphasis on facade is given  
exterior ramp access  
leads to storage on ramp and the cold storage walk-in
- 2 processing space**  
flexible use of carts as counters allow for unpacking, sorting, and processing food to support this site and the larger network  
large produce washing sink  
mop sink and floor drain for easy clean up
- 3 walk-in cold storage**  
8' x 10' walk-in cooler with interior shelving

- 4 ramp and shelving**  
used as dry and bulk storage  
allows for circulation of carts and people above level change  
5' wide ramp accommodates two-way traffic
- 5 greenhouse**  
visual access to food growing  
takes advantage of vertical space through hydroponic growing and a trellis system  
fits plant flats for growing seedlings
- 6 waste management facility**  
designated space for box breakdown, garbage and recycling bins, and on-site composting that can be used in the greenhouse

# market

**program** food shopping, free distributions, flexible gathering space

**capacity** 12 (60 sq ft/person)

**area** 730 sq ft

**public-private distinction**

private, visual access to food but people are not visually exposed to exterior

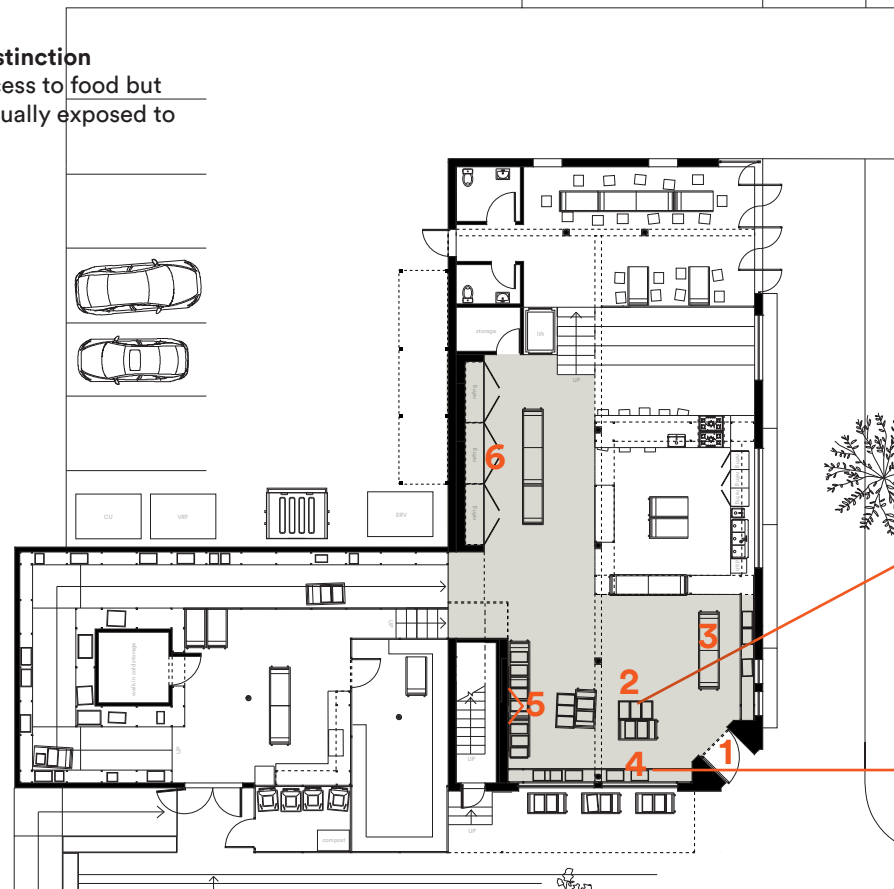

bin as food display

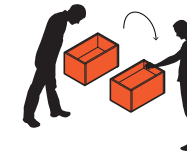

shelving as semi-permeable screen

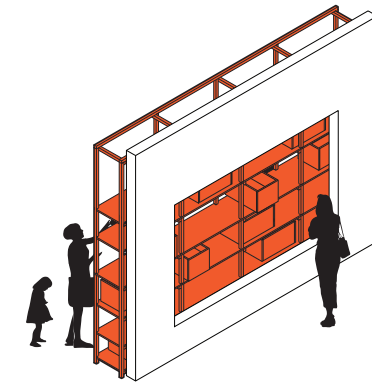

- 1 main entrance**  
orange polycarbonate door as clear indicator of being part of the network and grabs attention as the primary entrance point
- 2 food display**  
bins used as food display on shelving and carts 4" or 7" depth when flipped, able to hold varying amounts of food appropriately for easy access while avoiding the perception of food scarcity
- 3 cash wrap station**  
carts used as counters for check-out

- 4 shelving as semi-permeable screen**  
food display of dry goods and produce  
visual confirmation of food access from exterior  
partial visual obstruction preserves discretion on the interior
- 5 info boards**  
displays relevant information like offerings, pricing, or community events
- 6 refrigerators**  
cold storage for produce, prepared foods, and other refrigerated items

# kitchen

**program** kitchen incubator, community kitchen, cooking demonstrations

**capacity** 3 (200 sq ft/person)

**area** 650 sq ft

**public-private distinction** public, high visibility to cooking from exterior and other interior spaces

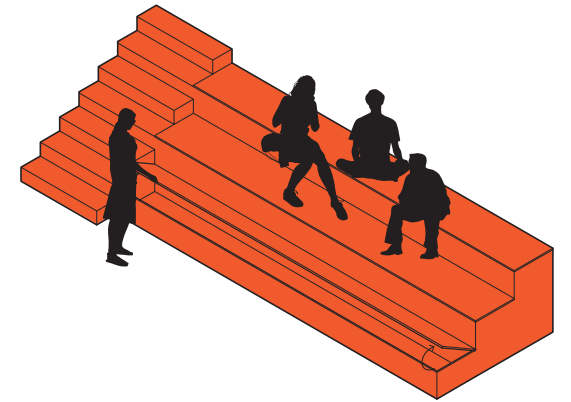
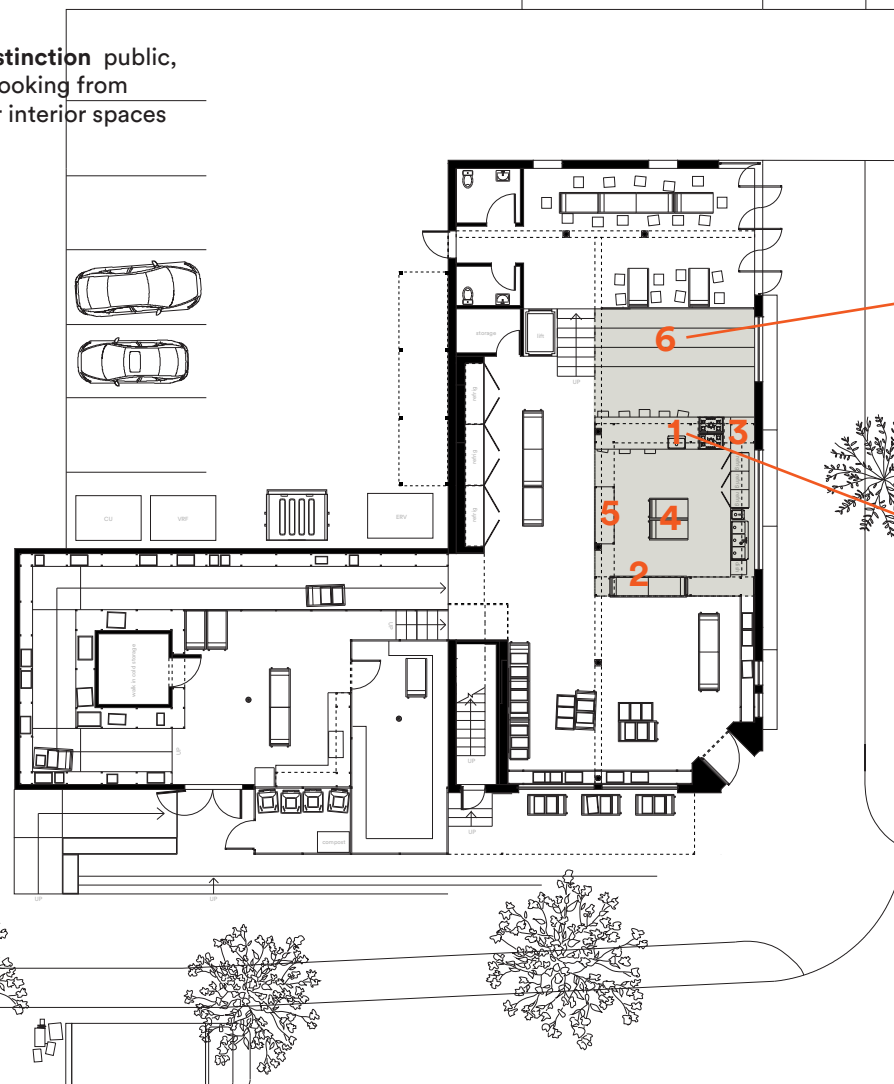

seating stairs

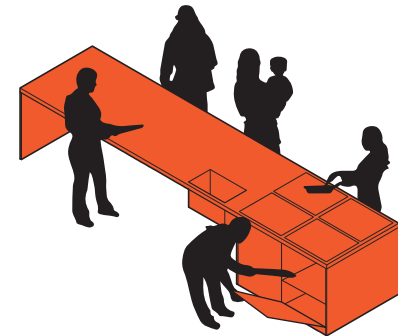

central cooking point

- 1 central cooking point**  
communal cooking around a central point  
prep sink, stove tops, undercounter ovens,  
open underneath for seating and wheelchair  
accessibility  
visually accessible for cooking demos
- 2 hanging shelving**  
defines the kitchen space and prevents  
circulation from impeding without visually  
disconnecting it from other interior spaces  
storage of kitchen tools and ingredients
- 3 commercial kitchen appliances**  
ovens, stoves, undercounter refrigerators,  
hood vent, dishwasher, and sinks for food  
prep, hand washing, and dishwashing

- 4 flexible food prep stations**  
carts used as food prep surfaces that can be  
moved around as needed  
accommodates use by a single person or  
groups of people  
storage of kitchen tools underneath
- 5 storage**  
undercounter, shelving, and storage closet for  
cooking ingredients and kitchen tools
- 6 seating stairs**  
collective seating element  
view of central cooking point  
storage within benches

# multi-use space

**program** community meetings and gatherings, small group events, classes, and other programs

**capacity** 24 (15 sq ft/person)

**area** 360 sq ft

**public-private distinction**

flexible visibility level to exterior depending on differing programs, partial privacy from other interior spaces

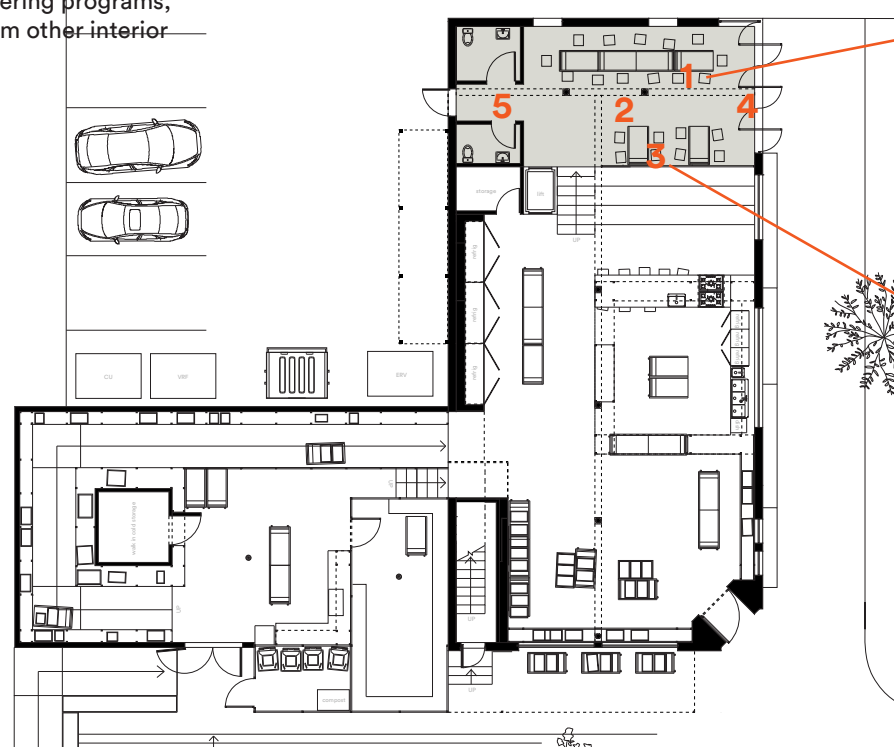

bin as seating



semi-permeable barrier

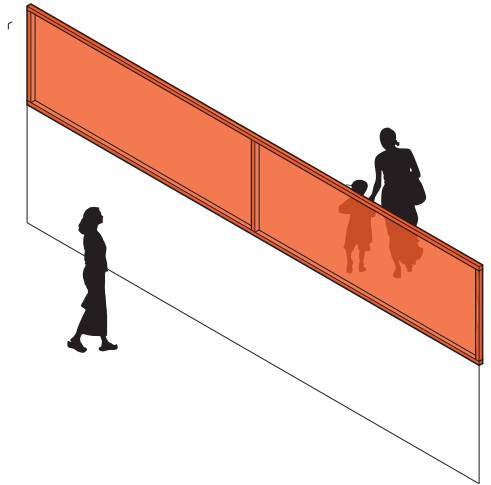

**1 bins as seating**

the food display bins flipped sideways become 22" stools for flexible seating

**2 flexible space**

open space inhabited by flexible secondary elements—bins for seating and carts as tables—allows the space to be used for various programs and events

**3 translucent polycarbonate screen**

a half-height screen placed at the top of the seating stairs creates a level of privacy between other interior spaces without disconnecting it

the translucent material retains some connection and the height change controls visual access into the space

**4 flexibility in privacy level**

pivoting polycarbonate doors allow for flexibility in the privacy level between interior and exterior, responding to varying needs of programs and events  
the translucent material allows for a level of visual connection between people at all times, while remaining discrete

**5 restrooms**

at least one ADA compliant restroom

# exterior

**program** exterior food display,  
gathering space, food transport  
**public-private distinction** public

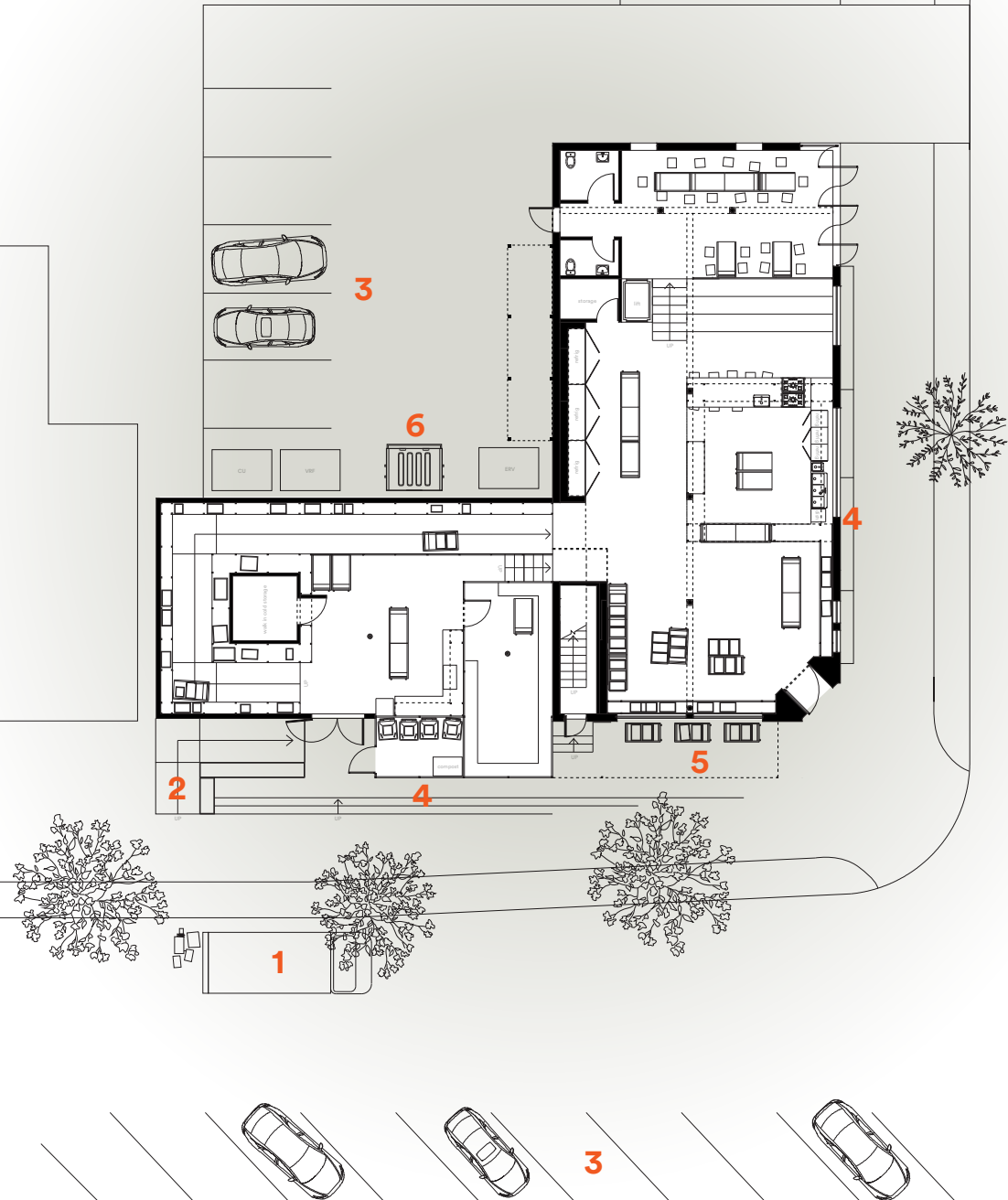

- 1 loading/unloading zone**  
a space for truck parking without disturbing traffic accommodates large amounts of incoming and outgoing food deliveries to support the network
- 2 exterior ramp**  
aids in easy movement of food in and out of the food center
- 3 parking**  
visitor parking, including handicap spots, either in a lot or nearby street parking

- 4 bench seating**  
outdoor gathering space activates the exterior standing on the benches allow people to peer through the taller windows and into the kitchen
- 5 exterior food display**  
allows the market space to flow outside visual access to food  
can also function as outdoor dining space
- 6 dumpster**  
handles large scale disposal of food packaging



# food cart

**material** pine 2x2s, birch plywood, aluminum sheet

**scale** 26" x 48" x 36"

**cost** single prototype cost \$150 in materials, mass production of prefabricated parts will cost less

**functions** food transport, shopping cart, food display, floor dining table, counter and food prep surface

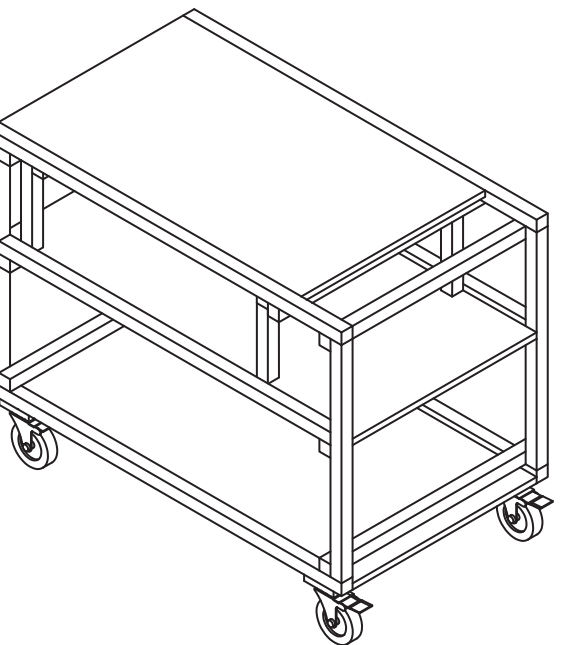
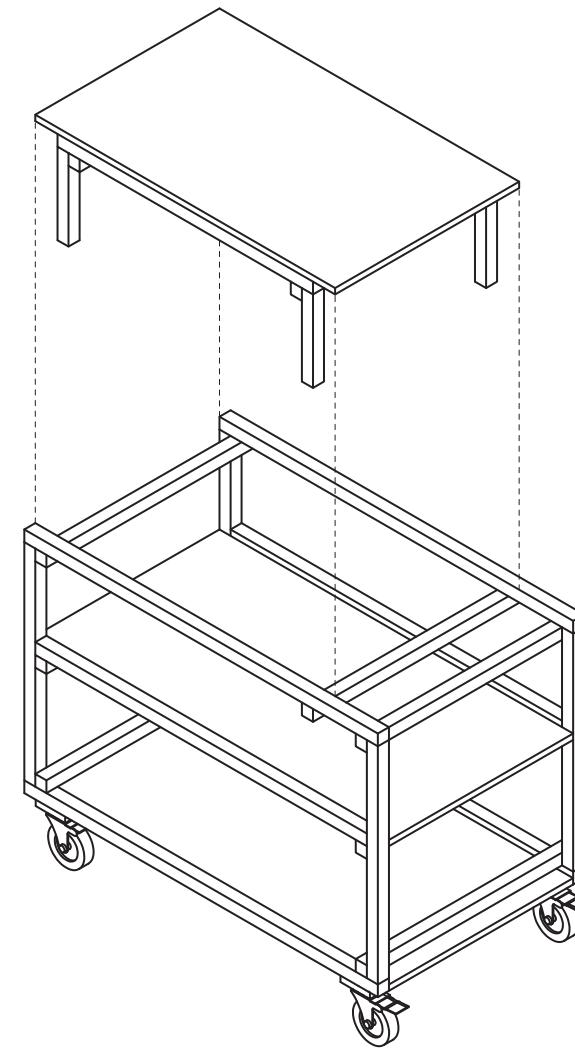
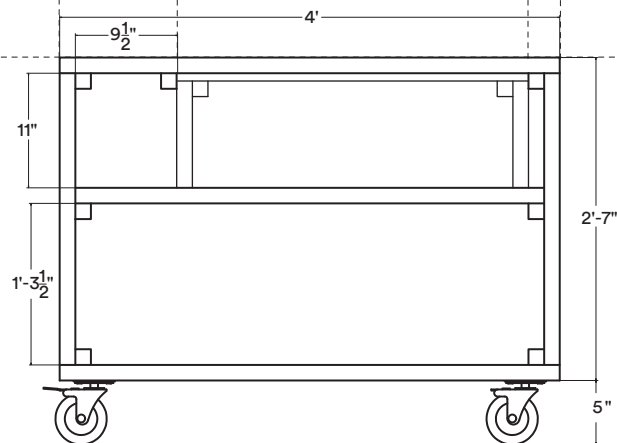
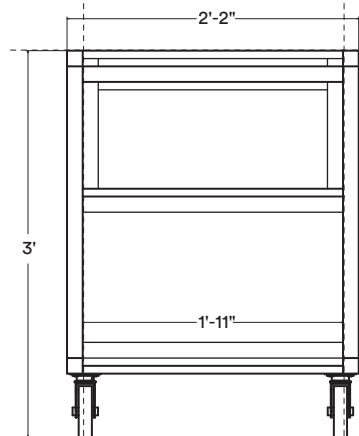
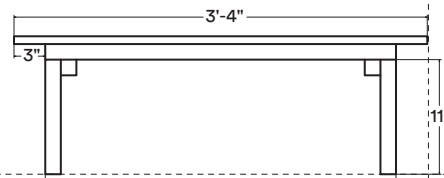
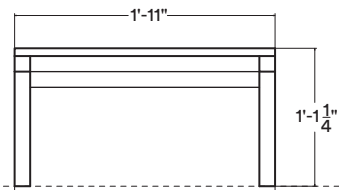
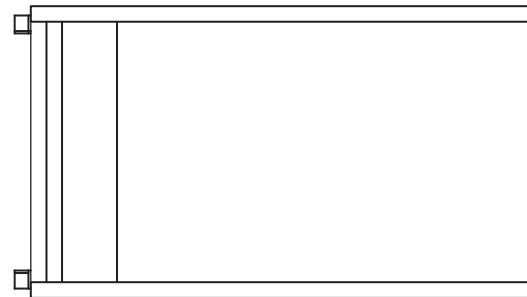

**configuration** food transport

**location** food center, market, kitchen, exterior

**function** with the table element separated, the main structure can transport food from truck deliveries to food center, from food center to kitchen and market, for food shopping, and for free food distributions

**details** a lip on either side of the bottom shelf and horizontal pieces of wood keep contents from sliding off of the shelf when in motion



**configuration** food display

**location** market, exterior

**function** when the table is separated, both pieces can hold bins of produce and other goods at easily reachable heights

**details** bins placed on the top shelf of the main structure (when the table is not attached) stand at 2', making it comfortable to reach in

the dimensions of the shelves accommodate the average size of milk crates and harvesting totes, fitting existing elements into the overall design



**configuration** floor dining table

**location** market, multi-use space

**function** when the table is separated, it can be used for dining at floor height and aggregating multiple can create a large dining table

**details** the width of the table is comfortable for a single person to remove it from the main structure  
the table height is 12", ideal for floor seating



**configuration** counter and food prep surface

**location** kitchen, food center, multi-use space

**function** the cart can be used both as a singular individual or small group work space, or aggregated for large group, collective activity, both in food prep, dining, and other programs as a table or desk

**details** a stainless steel sheet on the top creates a food safe surface for food prep

36" height is a comfortable height for stool seating and standing while cooking



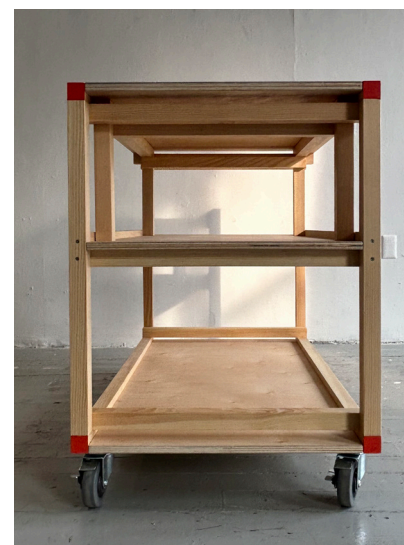

# configurations of flexible elements

Flexible elements—carts and bins as both food display and seating—allow the space to be populated in various ways, accommodating many programs within the same area. These elements are easily adaptable, allowing users to manipulate the space and function as they please. The following pages present three possible configurations: daily hours, community dinner, and free food distribution. Each configuration uses 30 carts as countertops, dining tables, food display, and food transport.

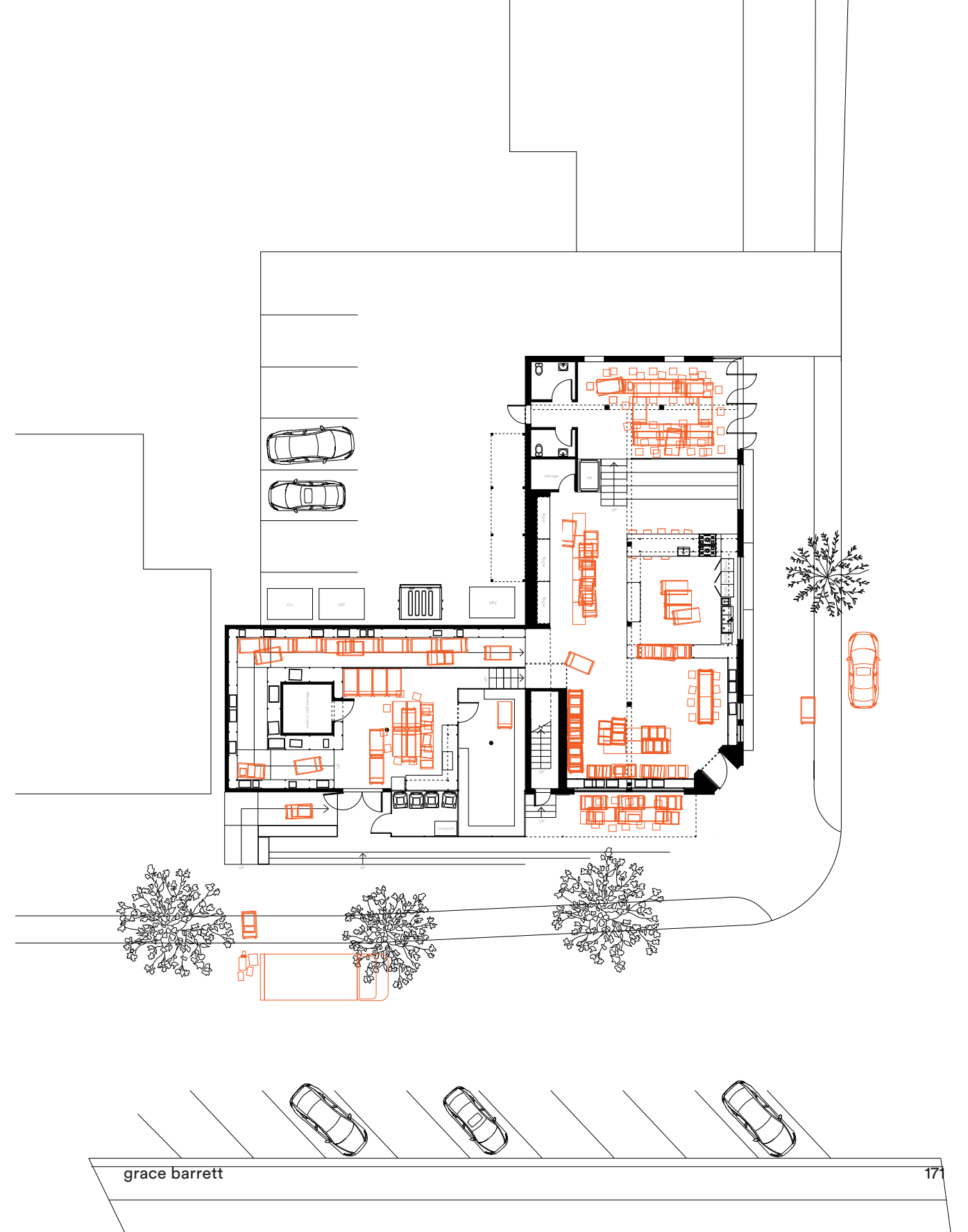

# daily hours

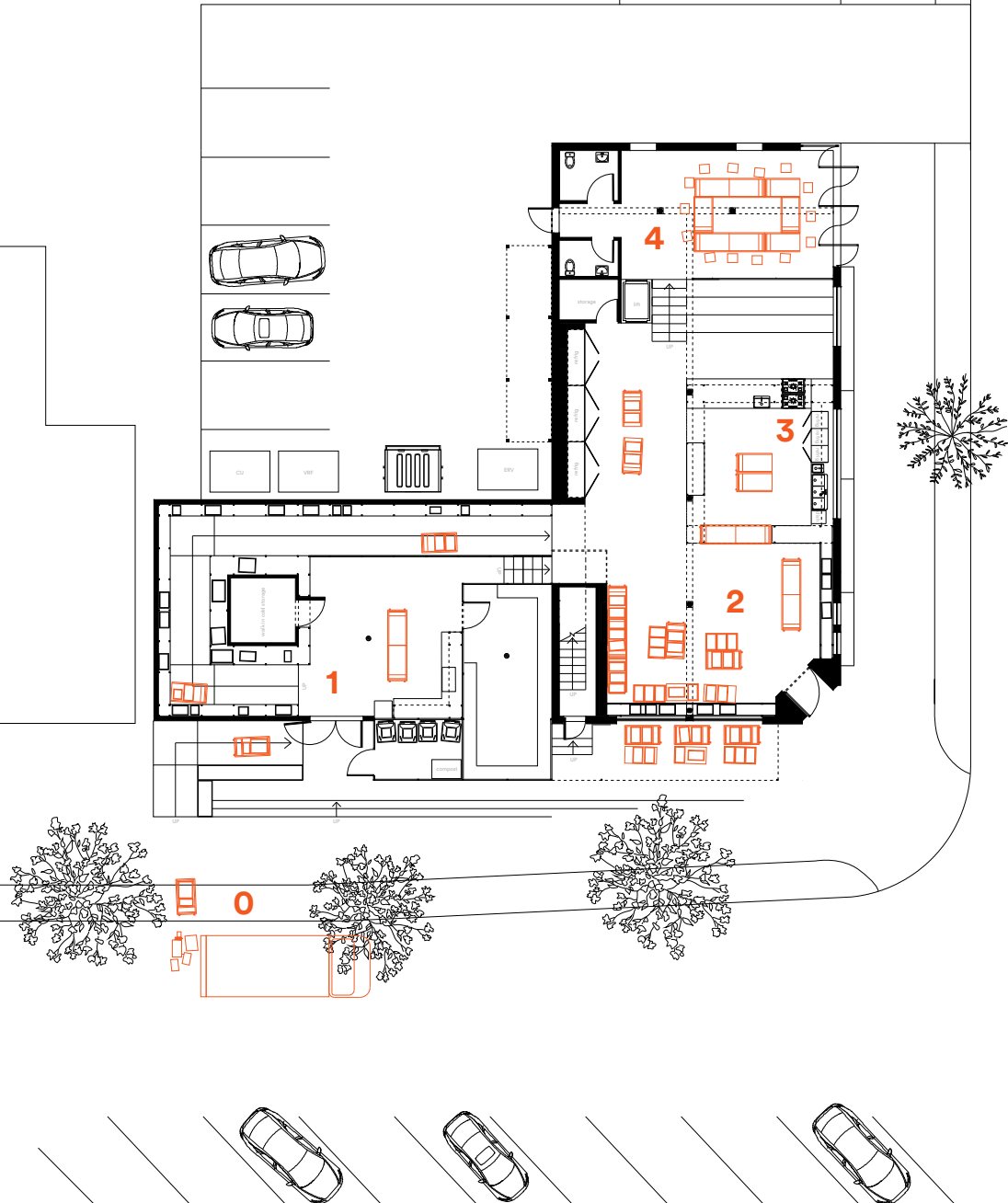

- 0** **outside** food delivery, using cart to transport food inside
- 1** **food center** organizing food, unloading into cold storage and shelving
- 2** **market** functioning as market, carts and bins as food display, spills outside into exterior market space
- 3** **kitchen** kitchen incubator, carts used as food prep counter, defines kitchen space and guides circulation around kitchen
- 4** **multi-use space** small group event, carts and bins in a circular formation as a table or work area for collective activities

# community dinner

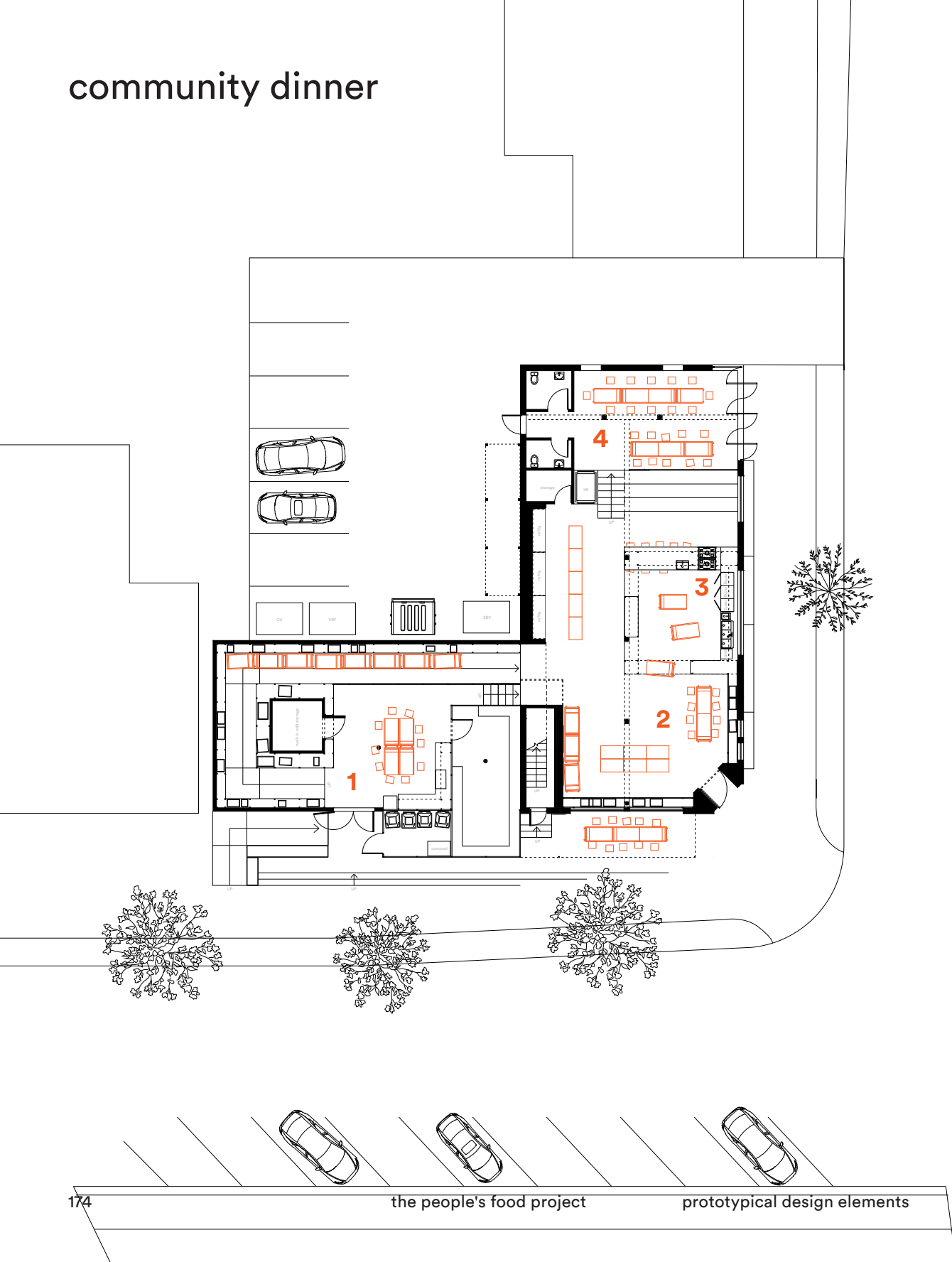

**1 food center** storage of main cart structure when the floor table is used elsewhere, using carts and bins for dining and gathering

**2 market** dining space, carts, bins, and floor table for collective dining, spills outside into exterior market space

**3 kitchen** collective cooking, carts in flexible configuration of food prep counters, bins to gather around central cooking point

**4 multi-use space** dining space, carts combined as long communal dining table with bins for seating

# free food distribution

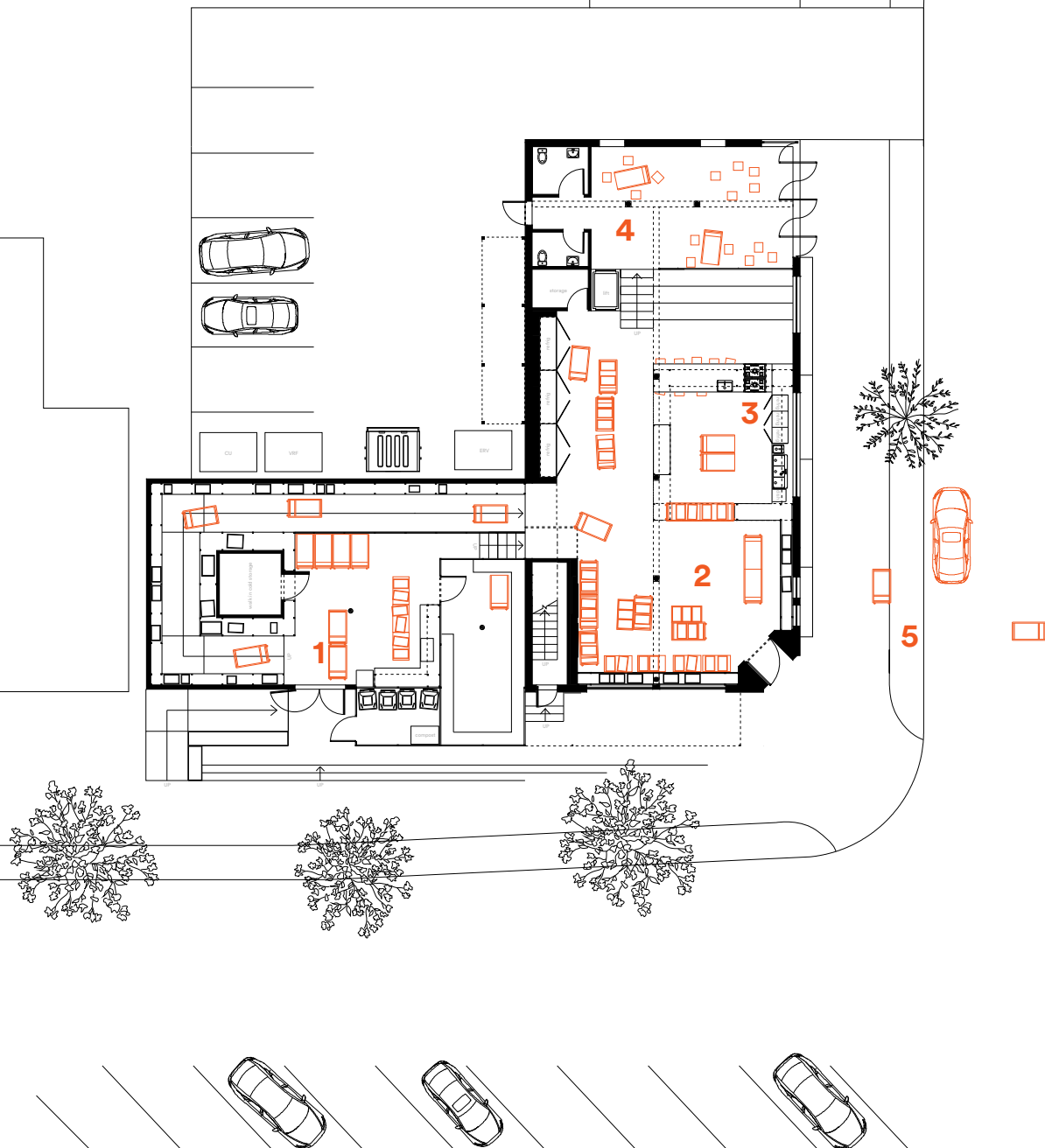

- 1 food center** bulk food distribution, using carts to pick food items off the ramp's shelves, extra carts stored in processing space
- 2 market** produce, refrigerated items, and dry goods distribution, carts and bins as food display
- 3 kitchen** cooking demonstrations, carts define space and loosely guide circulation, bins as seating around central cooking point

- 4 multi-use space** open, casual gathering space to encourage social interaction during food distributions, flexible organization of bins and carts
- 5 outside** loading food into car, using cart to transport food outside



# chapter 9: final design

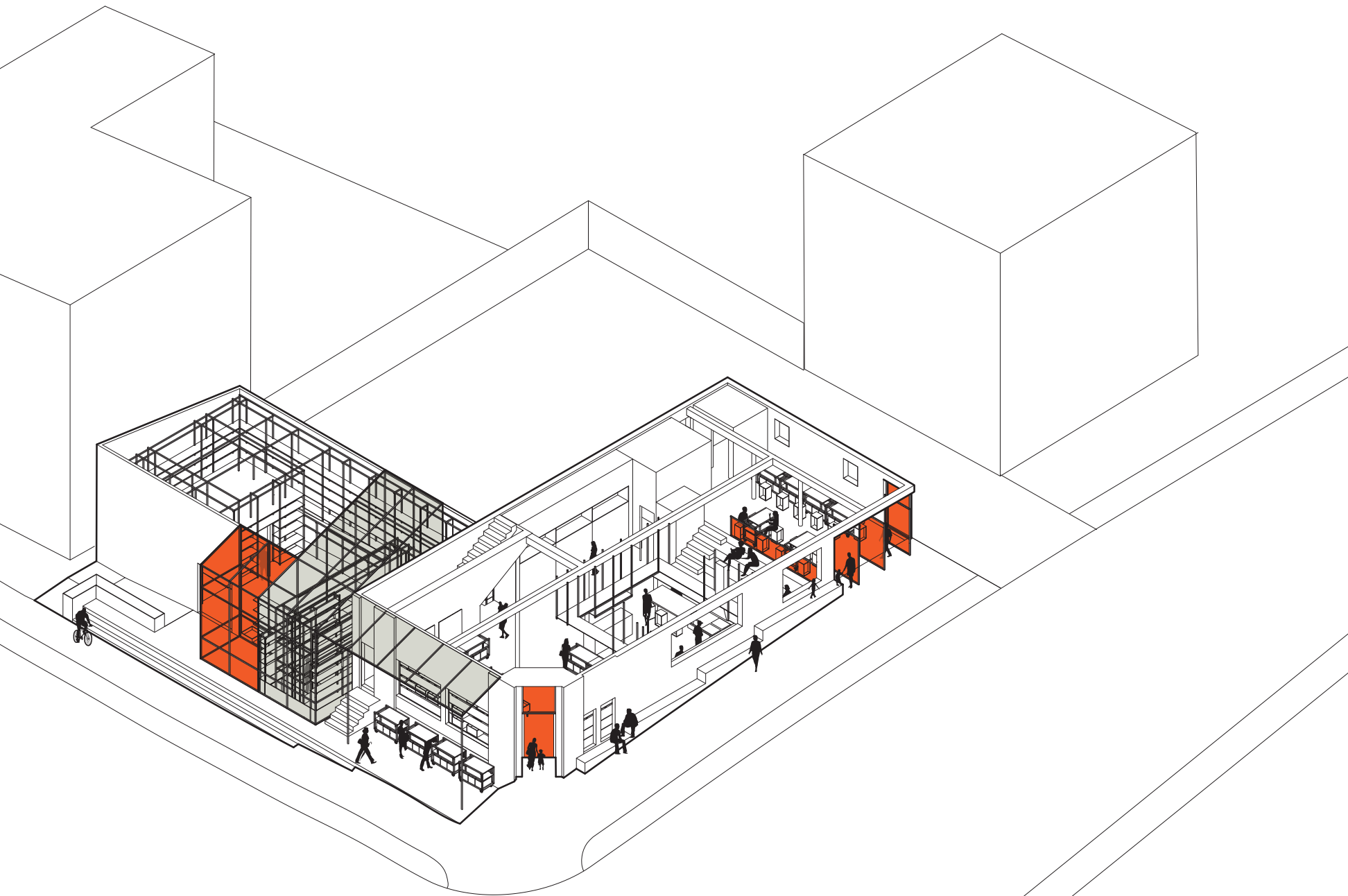

The drawings, model images, and renderings in this chapter exhibit the project's ability to embody the design principles, respond to the variable design elements, and contain the prototypical design elements. Visual accessibility is guaranteed through windows, the greenhouse, lack of physical barriers and a clear line of sight. The repetition in material—specifically the use of orange polycarbonate and the framework made out of 2x2s—creates a brand for the network that is easily identifiable and joins each separate site as part of a whole. The use of these materials marks old corner stores as new spaces of food access, shared food experiences, and gathering.





north facing section

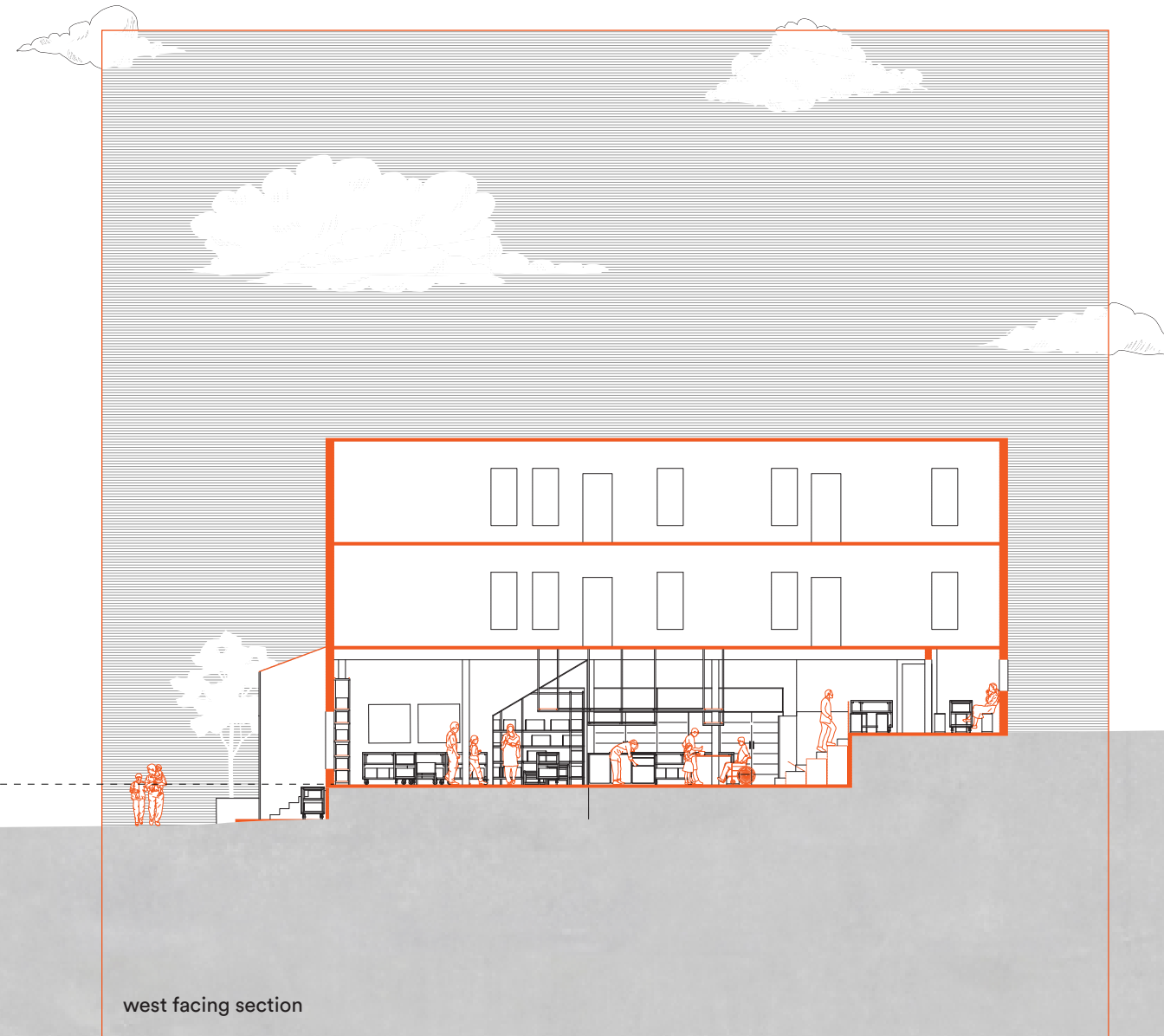

west facing section





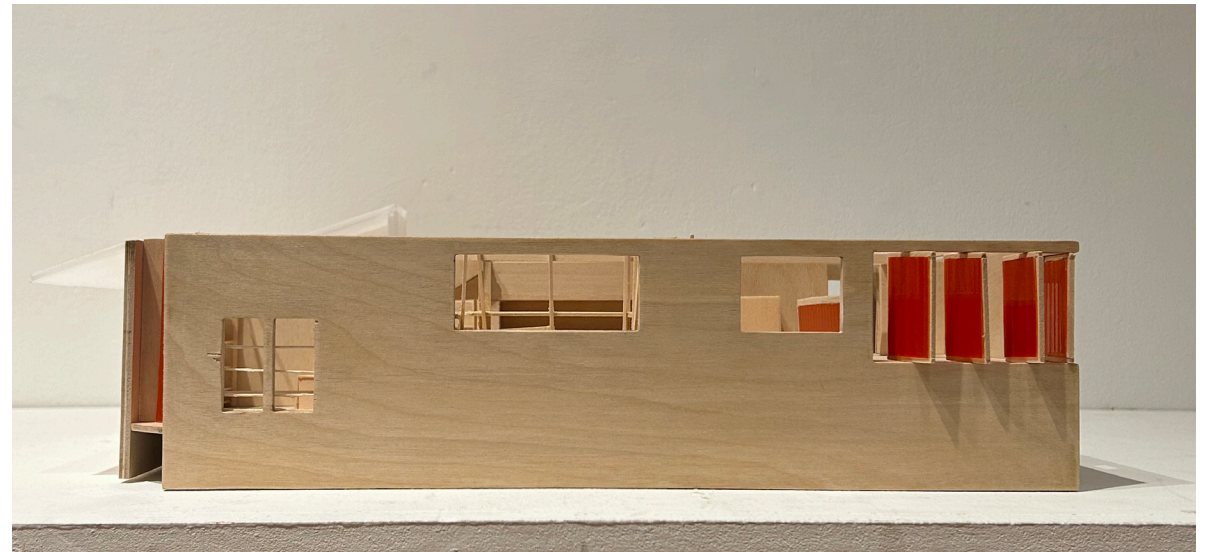



# bibliography

## Winooski

Andres, Glenn M. and Curtis B. Johnson. *Buildings of Vermont (Buildings of the United States)*. University of Virginia Press, 2014.

Berolzheimer, Alan and Michael Sherman eds. "Creating an Image: Reality of Life in Vermont" in Vermont Historical Society's Freedom & Unity exhibit. Vermont History, 2006. Accessed November 5, 2022. <https://vermonthistory.org/freedom-unity-reality-life-vermont>.

Cengeri, Ric and Jane Lindholm. "Winooski: Where It's Been And Where It's Headed." Vermont Public, December 9, 2014. <https://www.vermontpublic.org/programs/2014-12-09/winooski-where-its-been-and-where-its-headed>.

Chase, Kim. "History Space: Winooski – a 'p'Tit Canada.'" Burlington Free Press, 2016. Accessed November 4, 2022. <https://www.burlingtonfreepress.com/story/news/2016/06/10/history-space-winooski-ptit-canada/85671566/>.

"Historic Resource Inventory & Preservation Bylaw City of Winooski," City of Winooski. Accessed November 4, 2022.

"QuickFacts: Winooski City, Vermont." U.S. Census Bureau. Accessed November 12, 2022. <https://www.census.gov/quickfacts/winooskicityvermont>.

Wargo, William E. "Winooski Historical Society." Accessed November 4, 2022. <https://winooskihistory.wordpress.com/>.

"Preserve America, Winooski, Vermont" Advisory Council on Historic Preservation, 2006. Accessed November 5, 2022. <https://www.achp.gov/preserve-america/community/winooski-vermont>.

## food insecurity

Bose, Pablo, and Alisha Laramee. "Taste of Home: Migration, Food and Belonging in a Changing Vermont," 2011.

Bose, Pablo, Anitra Conover, and Lucas Grigri. "Refugee Communities in Vermont and Food Security in Response to COVID-19." 2021.

Burke, Madeleine, Ashley C McCarthy, Emily H Belarmino, Farryl Bertmann, and Meredith T Niles. "Food Security and Assistance Programs in Vermont Before and During COVID-19." 2021.

McCarthy, Ashley C, Farryl Bertmann, Emily H Belarmino, Sam Bliss, Jennifer Laurent, Jonathan Malacarne, Scott Merrill, Rachel E Schattman, Kathryn Yerxa, and Meredith T Niles. "A 2022 Assessment of Food Security and Health Outcomes during the COVID-19 Pandemic." 2022.

Niles, Meredith T, Emily H Belarmino, and Farryl Bertmann. *COVID-19 Impacts on Food Security and Systems: A Third Survey of Vermonters*, 2020.

Niles, Meredith T, Farryl Bertmann, Emily H Belarmino, Thomas Wentworth, Erin Biehl, and Roni Neff. "The Early Food Insecurity Impacts of COVID-19." *Nutrients* 12, no. 7 (2020): 2096.

Washington, Karen. *Empowering Our Communities to Transform the Food System - EcoFarm 2019 Keynote*. YouTube. YouTube, 2019. <https://www.youtube.com/watch?v=FmFS6WTTWYE>.

## refugee resettlement

Bhugra, Dinesh, and Matthew A Becker. "Migration, Cultural Bereavement and Cultural Identity." *World Psychiatry*, 2005.

Catania, Katie, and Kevin Coburn. "Resettled in Vermont" in *UVM Today*. The University of Vermont, 2022. Accessed January 26, 2023. <https://www.uvm.edu/news/story/resettled-vermont>.

"Refugees among Us: Winooski, Vermont." *Reno Gazette-Journal*, December 31, 2019. <https://data.rgj.com/refugee/vermont-winooski/all/>.

## architecture

Boboski, Kara. "A Client-Focused Abortion Health Centre: Creating a Sense of Comfort and Security through the Built Environment." *Winnipeg: University of Manitoba*, 2019.

Donovan, Jenny. "The Characteristics of Places that are Designed to Heal" in *Designing to Heal: Planning and Urban Design Response to Disaster and Conflict*, 261-278. Collingwood, VIC: CSIRO PUBLISHING, 2013.

Delugan-Meissl, Elke. *Social Furniture*. Edited by EOOS. London: Koenig Books Ltd, 2016.

Michailidis, Karolos. *Eating Architecture: Typologies of Food and Space*. University of Bath Department of Architecture and Civil Engineering, 2011. Accessed October 12, 2022. [https://issuu.com/karolos.michailidis/docs/eating\\_architecture](https://issuu.com/karolos.michailidis/docs/eating_architecture).



McLane, Yelena, and Jill Pable. “Architectural Design Characteristics, Uses, and Perceptions of Community Spaces in Permanent Supportive Housing.” *Journal of Interior Design* 45, no. 1 (March 2020): 33–52. <https://doi.org/10.1111/joid.12165>.

Nielsen, Brita Fladvad. “Out of Context: Ethnographic Interviewing, Empathy, and Humanitarian Design.” *Design Philosophy Papers* 12, no. 1 (May 2014): 51–64. <https://doi.org/10.2752/144871314X14012672862152>.

### **the corner store**

Campoli, Julie. “The Corner Store.” Accessed November 7, 2022. <https://www.juliecampoli.com/new-blog-avenue/2015/7/27/the-corner-store>

“Food, Community, and Family in the Markets of Burlington and Winooski, Vermont.” In *More Than a Market Exhibition*. Historic New England, 2022. Accessed November 6, 2022. <https://morethanamar-ket.org/>.

### **food assistance**

Bertmann, Farryl, Emily H Belarmino, Thomas Wentworth, Erin Biehl, Roni Neff, and Meredith T Niles. *Food Access Through School Meals and Food Pantries During COVID-19: Early Findings from Vermont*, UVM ScholarWorks, 2020.

Bertmann, Farryl, Katherine Rogomentich, Emily H Belarmino, and Meredith T Niles. “The Food Bank and Food Pantries Help Food Insecure Participants Maintain Fruit and Vegetable Intake During COVID-19.” *Frontiers in Nutrition (Lausanne)* 8 (2021): 673158.

De Souza, Rebecca T. *Feeding the Other: Whiteness, Privilege, and Neoliberal Stigma in Food Pantries*. Cambridge, MA: MIT Press, 2019

### **communal cooking and eating**

Aikawa, Miho. “Table: Dinner in New York + Dinner in Tokyo,” in *Food Revolution 5.0: Gestaltung Für Die Gesellschaft von Morgen*, edited by Claudia Banz and Sabine Schulze, Verlag Kettler, 2017.

Engel, Toya and Victoria Mutzek. “Kitchen: Communal Cooking Landscape,” in *Food Revolution 5.0: Gestaltung Für Die Gesellschaft von Morgen*, edited by Claudia Banz and Sabine Schulze, Verlag Kettler, 2017.

Enloe, James. “Food Sharing Past and Present: Archaeological Evidence for Economic and Social

Interactions.” *Before Farming* 2003, no. 1 (January 2003): 1–23. <https://doi.org/10.3828/bfarm.2003.1.1>.

Tanyeri, Dana. “Functional by Design: Teaching Kitchens.” *Foodservice Equipment & Supplies*, July 2, 2018. Accessed November 20. <https://fesmag.com/topics/trends/16027-functional-by-design-teaching-kitchens>.

Werner Aisslinger. “Kitchen: Communal Cooking Landscape,” in *Food Revolution 5.0: Gestaltung Für Die Gesellschaft von Morgen*, edited by Claudia Banz and Sabine Schulze, Verlag Kettler, 2017.

Zwaag, Anne van der. *Looks Good, Feels Good, Is Good. How Social Design Changes Our World*. Lecturis, 2014.

# image credits

**cover, page 76, page 140** Winooski Historical Society. "7 to 11 Market." Photograph. n.d. More Than A Market. Accessed February 26, 2023. <https://morethanamarket.org/>

**page 16** Maurizio Cattelan and Pierpaolo Ferrari. "The Food Issue October 9, 2016." Magazine Cover. 2016. The New York Times Magazine. Accessed April 24, 2023. <https://archive.nytimes.com/www.nytimes.com/indexes/2016/10/09/magazine/index.html>

Murat Erturk. "Poster on Poverty and Hunger Around the World." Poster. 2017. Accessed April 24, 2023. [http://www.muraterturk.com/poster\\_poverty.html](http://www.muraterturk.com/poster_poverty.html)

**page 18** San Francisco Diggers distributing free food. Photograph. 1966. The Digger Archives. Accessed April 24, 2023. <https://www.diggers.org/>

**page 19** Adela Wagner. "The Bed-Stuy Community Fridge." Photograph. 2020. Curbed New York. Accessed April 24, 2023. <https://ny.curbed.com/2020/5/29/21274491/community-fridges-nyc-brooklyn-covid-19>

Bruce Reeve. "Indoor Farmer's Market." Photograph. 2011. Flickr. Accessed April 10, 2023. <https://www.flickr.com/photos/58609798@N00/6332481723/>

**page 20** Mike Meiré. "The Farm Project." Photograph. 2008. Meiré and Meiré. Accessed May 6, 2023.

**page 21** "Happy Holidays circa 1962." Photograph. 1962. Flashbak. Accessed May 5, 2023.

**page 22** Miho Aikawa. "Dinner in New York." Photographs. 2014. Miho Aikawa Photography. Accessed May 6, 2023.

**page 23 top and bottom** Natalie, last name unknown. "The Rome Sustainable Food Project." Photographs. 2014. Rome. Food. Travel. Accessed May 5th, 2023. [\[inrome.com/2014/06/the-rome-sustainable-food-project/\]\(https://inrome.com/2014/06/the-rome-sustainable-food-project/\)](https://anamerican-</a></p></div><div data-bbox=)

**middle** Rosanna Morris. "Food Sovereignty Now!" Poster. La Via Campesina. Accessed May 5, 2023. <https://viacampesina.org/en/twenty-five-years-of-envisioning-food-sovereignty-celebrating-diversity-resilience-and-transforming-the-society/>

**page 24** Ángela Carvajal and Sebastián López. "Open Wall." Axonometric Drawing. 2018. Anagramma Arquitectos. Accessed May 20, 2023. <http://www.anagramma-arq.com/13-openwall>

**page 25** Natalie, last name unknown. "The Rome Sustainable Food Project." Photograph. 2014. Rome. Food. Travel. Accessed May 5th, 2023. <https://anamericaninrome.com/2014/06/the-rome-sustainable-food-project/>

**page 26** AALV. "NFNA Photo." Photograph. 2017. AALV. Accessed May 5, 2023. <https://www.aalv-vt.org/nfna-photo-gallery>

**page 32** Feeding America. "Food Insecurity among Overall (all ages) Population in the United States." 2021. Feeding America. Accessed April 30, 2023. <https://map.feedingamerica.org/county/2021/overall>

**page 36, 74** Louis L. McAllister. "Winooski, VT - Winooski River and Mills." Photograph. 1920s. Louis L. McAllister Photographs. University of Vermont Libraries, Special Collections. Accessed November 5, 2022.

**page 38** Vermont Center for Geographic Information Parcel Viewer. Accessed November 16, 2022. <https://maps.vcgi.vermont.gov/parcelviewer/>

**page 39** Ken J. New England Population Density by Town - Municipality. Map Diagram. 2022. Modern Survival Blog. Accessed November 12, 2022. <https://modernsurvivalblog.com/life-style/northeast-population-density/>

**page 42** Louis L. McAllister. "Portraits - Unidentified Groups."

Photograph. 1935. Louis L. McAllister Photographs. University of Vermont Libraries, Special Collections. Accessed December 12, 2022.

**page 44** Louis L. McAllister. "Veterans of Foreign Wars." Photograph. 1957. Louis L. McAllister Photographs. University of Vermont Libraries, Special Collections. Accessed December 12, 2022.

**page 45** Louis L. McAllister. "Camp Marycrest - Misc." Photograph. 1948. Louis L. McAllister Photographs. Center for Digital Initiatives, University of Vermont Libraries. Accessed December 12, 2022.

**page 46** "Bird's Eye View #2, Winooski, Vt. River and Mill District." Postcard. n.d. Winooski's Legacy Campaign, Historical Walking Tour. Accessed April 9, 2023. <https://www.legacy.winooskivt.gov/tour>

**page 47** Jason Stuffle. "The Gorge, Winooski, VT., Near Burlington." Postcard. n.d. Facebook, Winooski Vermont Historical Society. Accessed November 5, 2022. <https://www.facebook.com/photo/?fbid=5878101405538882&set=pcb.10159873785741605>

Joseph Pernon. "Main Street, Winooski, Vermont." Postcard. 1920. Facebook, Winooski Vermont Historical Society. Accessed November 5, 2022. <https://www.facebook.com/photo/?fbid=10217115082709118&set=pcb.10159917791026605>

**page 49** Louis L. McAllister. "Burlington Streets: Colchester Ave." Photograph. 1929. Louis L. McAllister Photographs. University of Vermont Libraries, Special Collections. Accessed November 5, 2022.

**page 50** Bob Blanchard. Photograph. n.d. Facebook, Burlington Area History. Accessed November 5, 2022. <https://www.facebook.com/photo/?fbid=10216078955182749&set=gm.624090724834700>

**page 51** Joseph Perron. Photograph. 1969. Facebook, Winooski Vermont Historical Society. Accessed April 15, 2023. <https://www.facebook.com/photo?fbid=10216429071239260&set=gm.10159590320421605>

**page 52** Seven Days. Photograph. 2018. Accessed April 9, 2023. <https://www.sevendaysvt.com/vermont/soundbites-jazz-fest-winooski-style/Content?oid=16344423>

**page 54** Vermont Center for Geographic Information Parcel Viewer. Accessed November 16, 2022. <https://maps.vcgi.vermont.gov/parcelviewer/>

**page 60** "Chick's Market." Photograph. n.d. More Than A Market. Accessed February 26, 2023. <https://morethanamarket.org/>

**page 62** James Detore. "Corey's Market." Photograph. 1948. Detore Collection, University of Vermont Special Collections. Accessed February 26, 2023. <https://morethanamarket.org/>

"Bellino's Market." Photograph. 1928. Vermont Italian Cultural Association. Accessed February 26, 2023. <https://morethanamarket.org/>

Louis Mario Izzo. "Izzo's Market." Photograph. 1930. More Than a Market. Accessed February 26, 2023. <https://morethanamarket.org/>

**page 63** B. Barker Benton. "Merola's Market." Photograph. n.d. Barker Collection, University of Vermont Special Collections. Accessed February 26, 2023. <https://morethanamarket.org/>

**page 65** Vermont Center for Geographic Information Parcel Viewer. Accessed November 16, 2022. <https://maps.vcgi.vermont.gov/parcelviewer/>

**page 66-67** Joseph Perron. "Winooski's Restaurant." Photograph. n.d. Facebook, Winooski Vermont Historical Society. Accessed November 5, 2022. <https://www.facebook.com/photo/?fbid=10217370850583155>

Bob Blanchard. "A&W Root Beer." Photograph. n.d. Facebook, Burlington Area History. Accessed November 5, 2022. <https://www.facebook.com/groups/502280600349047/permalink/1126011227975978/>

[com/groups/502280600349047/permalink/1126011227975978/](https://www.facebook.com/groups/502280600349047/permalink/1126011227975978/)

Bob Blanchard. "Snack Bar." Photograph. n.d. Facebook, Burlington Area History. Accessed November 5, 2022. <https://www.facebook.com/groups/502280600349047/permalink/1126011227975978/>

Bob Blanchard. "Boye's restaurant." Photograph. n.d. Facebook, Burlington Area History. Accessed November 5, 2022. <https://www.facebook.com/groups/502280600349047/permalink/1126011227975978/>

Bob Blanchard. "7 to 11 Market." Photograph. n.d. Facebook, Burlington Area History. Accessed November 5, 2022. <https://www.facebook.com/groups/502280600349047/permalink/1126011227975978/>

Julie Campoli. "Himalayan Food Market." Photograph. 2014. Vermont's Natural Resources Council. Accessed November 30, 2022. <https://vnrc.org/people-places-transportation/bring-back-the-corner-store/>

"Vic's Meats." Photograph. n.d. Winooski Historical Society. More Than A Market. Accessed February 26, 2023. <https://morethanamarket.org/>

"Tom's Market." Photograph. n.d. Winooski Historical Society. More Than A Market. Accessed February 26, 2023. <https://morethanamarket.org/>

Bob Blanchard. "Chick's Market." Photograph. n.d. Facebook, Burlington Area History. Accessed November 5, 2022. <https://www.facebook.com/groups/502280600349047/permalink/1126011227975978/>

Julie Campoli. "Brixton Halaal Meats & Products." Photograph. 2014. Vermont's Natural Resources Council. Accessed November 30, 2022. <https://vnrc.org/people-places-transportation/bring-back-the-corner-store/>

James Detore. "Corey's Market." Photograph. n.d. Detore Collection, University of Vermont Special Collections. Accessed February 26, 2023. <https://morethanamarket.org/>

Sr. Marie Kieslich. "Kieslich's Market." Photograph. n.d. More Than a Market. Accessed February 26, 2023. <https://morethanamarket.org/>

Julie Campoli. "Mawuhi African Market." Photograph. 2014. Vermont's Natural Resources Council. Accessed November 30, 2022. <https://vnrc.org/people-places-transportation/bring-back-the-corner-store/>

Bob Blanchard. "Main St. Superette." Photograph. n.d. Facebook, Burlington Area History. Accessed November 5, 2022. <https://www.facebook.com/groups/502280600349047/permalink/1126011227975978/>

Joseph Perron. "Dufresne's Gulf." Photograph. n.d. Facebook, Winooski Vermont Historical Society. Accessed November 5, 2022. <https://www.facebook.com/photo?fbid=10216668260218835&set=pcb.1015970818111605>

"George's Market." Photograph. n.d. More Than a Market. Accessed February 26, 2023. <https://morethanamarket.org/location/georges-market/>

Bob Blanchard. "I.G.A. Stores." Photograph. 1946. Facebook, Burlington Area History. Accessed November 5, 2022. <https://www.facebook.com/photo?fbid=10217478938221450&set=pcb.739040380006400>

Google Street View. Photograph. 2019. Google Maps. Accessed April 4, 2023. <https://www.google.com/maps/place/141+N+Willard+St,+Burlington,+VT+05401>

**page 70, 72** Vermont Center for Geographic Information Parcel Viewer. Accessed December 12, 2022. <https://maps.vcgi.vermont.gov/parcelviewer/>

**page 76-77** Joseph Perron. "1980 Fire." Photograph. 1980. Facebook, Winooski Vermont Historical Society. Accessed April 15, 2023. <https://www.facebook.com/groups/93986296604/permalink/10159477977361605/>

"Emmon's Market." Photograph. 1993. State of Vermont Division for Historic Preservation. Accessed November 9, 2022.

**page 78** Google Street View. Photograph. 2019. Google Maps. Accessed April 4, 2023. <https://www.google.com/maps/place/35+W+Allen+St,+Winooski,+VT>

**page 79** "35 W Allen St." Photographs. n.d. Zillow. Accessed November 10, 2022. [https://www.zillow.com/homedetails/35-W-Allen-St-Winooski-VT-05404/220878640\\_zpid/](https://www.zillow.com/homedetails/35-W-Allen-St-Winooski-VT-05404/220878640_zpid/)

**page 90** Winooski Food Shelf. Photographs. 2019. Winooski Food Shelf. Accessed April 5, 2023. <http://www.winooskifoodshelf.org/>

**page 92** top left Bruce Wilson. Photograph. 2023. Facebook, Centre Street Food Pantry. Accessed April 9, 2023. <https://www.facebook.com/photo/?fbid=573366064835701&set=pcb.573366144835693>

top right and bottom Centre Street Food Pantry. Photographs. n.d. Centre Street Food Pantry. Accessed April 9, 2023. <https://www.centrestreetfoodpantry.org/>

**page 94** Lena Greenberg. Photographs. 2022. If You Want to Feed People, Give Them Food. Accessed February 9, 2023.

**page 102** Timothy Hursley. "Ozark Natural Foods Co-op." Photograph. 2020. Accessed April 16, 2023.

**page 103** Alex Campbell. "River Cottage, HQ." Photograph. 2014. Accessed April 16, 2023.

**page 104** Heami Lee. "Reyes Deli & Grocery peddles American and Mexican chips." Photograph. 2020. Culture Trip. Accessed April 7, 2023.

Heami Lee. "New York City would not be the city it is today without bodegas." Photograph. 2020. Culture Trip. Accessed April 7, 2023.

Mary Rizos. "Everest Market." Photograph. n.d. More Than a Market. Accessed February 26, 2023. <https://morethanamarket.org/>

**page 112-113** Pixelmoreno. Photographs. 2014. Accessed November 7,

2022. <https://www.nuaarquitectures.com/en/sda-campclar/>

NUA architectures. Section Drawing. 2014. November 7, 2022. <https://www.nuaarquitectures.com/en/sda-campclar/>

NUA architectures. Floor Plan. 2014. November 7, 2022. <https://www.nuaarquitectures.com/en/sda-campclar/>

**page 114-115** left and right images Ilana Bessler. Photograph. 2016. Arch Daily. Accessed December 12, 2022. <https://www.archdaily.com/801230/refettorio-gastromotiva-metro-arquitetos-associados>

center image Angelo Dal Bó. Photograph. 2016. Arch Daily. Accessed December 12, 2022. <https://www.archdaily.com/801230/refettorio-gastromotiva-metro-arquitetos-associados>

METRO Arquitetos Associados. Floor Plan. 2016. Arch Daily. Accessed December 12, 2022. <https://www.archdaily.com/801230/refettorio-gastromotiva-metro-arquitetos-associados>

**page 116-117** Paul Kranzle. "Social Furniture." Photographs. 2016. Core 77 Design Awards. Accessed April 11, 2023. <https://designawards.core77.com/Open-Design/60074/eoos.com/sf>

EOOS. "SF Collection." Drawings. 2016. Open Design Manual: Social Furniture. Accessed April 11, 2023.

**page 118-119** Nina Pawlicki. "Cooking Class." Photograph. Kitchen-Hub. Accessed December 12, 2022.

Nina Pawlicki. "The Kitchen-Hub Storefront, Rote Insel." Photograph. Kitchen-Hub. Accessed December 12, 2022.

Theodora Constantin, Judith Schiebel, and Vanessa Vogel. "Conceptual Floorplan." Concept Drawing. Kitchen-Hub. Accessed December 12, 2022.

Simon Colwill. "Modular Toolkit." Axonometric Drawing. Kitchen-Hub. Accessed December 12, 2022.

**page 120-121** Niclas Mäkelä. Photographs. n.d. Design Stories. Accessed November 7, 2022. <https://www.finnishdesignshop.com/design-stories/architecture/alvar-aalto-saynatsalotown-hall-is-a-masterpiece-that-represents-more-humanistic-design>

Wittenburg & Company. Section Drawing. n.d. Arch Daily. Accessed November 7, 2022. <https://www.archdaily.com/783392/ad-classics-saynatsalotown-hall-alvar-aalto>

**page 122-123** SHINKENCHIKU-SHA. Photographs. Divisare. Accessed April 12, 2023. <https://divisare.com/projects/283550-kengo-kuma-and-associates-nest-we-grow-memumeadows>

UC Berkeley CED Graduate Team. East Elevation Drawing. Divisare. Accessed April 12, 2023. <https://divisare.com/projects/283550-kengo-kuma-and-associates-nest-we-grow-memumeadows>

**page 150-151** center Yosuke Ohtake. "House in Kyoto." Photograph. 2019. 07BEACH, Arch Daily. Accessed April 5, 2023. <https://www.archdaily.com/920871/house-in-kyoto-07beach>

**right** Iris Rodet. "Association Building, Communal Kitchen, Storage Facilities." Photograph. 2022. Lis & Daneau, Divisare. Accessed April 5, 2023. <https://divisare.com/projects/469633-lis-daneau-iris-rodet-association-building-communal-kitchen-storage-facilities>

**top right** Andre Klotz. "Dois Trópicos." Photograph. 2020. MNMA, Dezeen. Accessed April 5, 2023. <https://www.dezeen.com/2020/08/09/dois-tropicos-sao-paulo-wellness-mnma/>

