

Electric Powertrain Modeling and Control in Vehicular Applications using Energetic Macroscopic Representation

Théo Lenoir¹, João Pedro F. Trovão^{1,2}, Minh Cao Ta^{1,3}, Pascal Messier¹

¹e-TESC Lab., University of Sherbrooke, Sherbrooke, QC, J1K 2R1, Canada

²IPC-ISEC and INESC Coimbra, 3030-199 Coimbra, Portugal

³CTI for EV Lab., Hanoi University of Science and Technology, Hanoi, Vietnam

Abstract—The Energetic Macroscopic Representation (EMR) is a formalism that focuses on the energetic exchanges of various systems that are connected together. It allows to represent the macroscopic interactions between them through an intuitive graphical representations. The EMR formalism is based on the concept of a macroscopic energy balance, which is used to describe the overall energy conversion process. It is useful for representing the physical behavior of complex energy systems, such as power plants, solar panels, or vehicle powertrains. The graphical representation allows easier understanding and direct control of the system behavior, as well as the ability to quickly identify and troubleshoot potential model issues. Additionally, the EMR formalism can be used to develop control systems for energy systems, such as for optimal operation and energy efficiency. This paper will present the principles of EMR and introduce several vehicle powertrain engineering studies using EMR.

Keywords—modeling, control, powertrain, electric vehicles, graphical formalism

I. INTRODUCTION

Mainly due to the rise of environmental concern along with the scarcity of oil, thermal vehicles have sought their replacement for decades now. Electric vehicles have been an important prospect during all these years, and still draw huge interest. To improve their performances and therefore their attractiveness, these vehicles have become more and more complex. It is the case for every developing technologies, and it gets harder to model physical systems and each of their subsystem. Especially, it becomes quickly impossible to have numerical simulations of complex systems, as the computation time grows fast with their size. It is why, in the majority of cases, the most accurate models are not desirable. Indeed, it is often that only the macroscopic quantities are bound to be followed. Having these simpler models would allow

for quicker numerical simulations. It would therefore help considering complex systems as a whole and not just as a sum of several smaller subsystems. It is in that context that EMR was first thought of and then developed in the beginning of the 2000s by the L2EP (*Laboratoire d'électrotechnique et d'électronique de puissance*) lab. in Lille, France [1]. It was initially made for studying coupled electromechanical systems, but it has been extended to wider fields, such as thermodynamics [2]. EMR's philosophy is to start back from scratch and base its founding on the interaction principle and, especially, on the causality theory. The first one states that for every physical system, interacting with it through any physical quantity will lead to a response from the system. This will be formalised by the EMR through the concepts of actions and reactions. The principle of causality states that if any physical phenomena, that is named cause, induces another phenomena, named the effect, then the effect can only occur after the cause. In particular, it implies that through differential equations, the effect can only be written in terms of the integral of the cause, and not the other way around. Indeed, it would lead to discontinuities in the evolution of the physical quantities in relation to the time, and therefore require infinite power. EMR will be written with respect to these two principles. There are energetic models similar to EMR, such as bond graph (BG) or causal ordering graph (COG). EMR is a formalism based on functionalities rather than description, which allows more virtualization possibilities. Nowadays, EMR has reached out to a lot of professors, researchers, and engineers in industry and academia. Some of them are University of Sherbrooke (Canada), University of Lille (France), UQTR (*Université du Québec à Trois-Rivières*, Canada) or Hanoi University of Science and Technology (Vietnam) [3]. A few companies are also incorporating EMR to their research and development department, such as Stellantis, Renault Group, or SNCF.

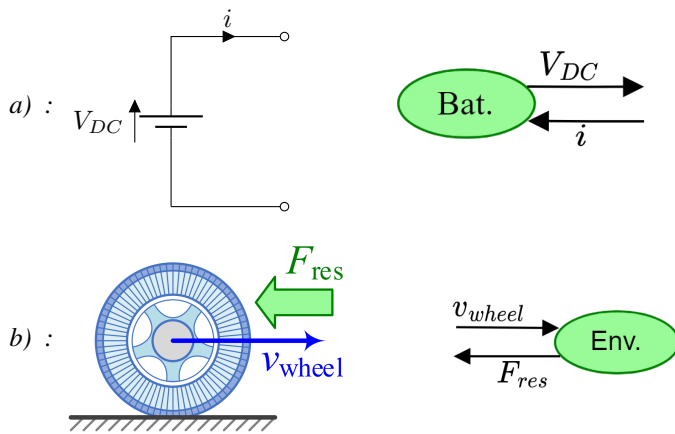

Figure 1. Examples of source elements in EMR formalism : a) DC source like battery and b) road resistant force

This paper will first present the basis of EMR as well as its formalism in three main aspects. It will first tackle the modeling of complex systems, then present how EMR is a great formalism for control loops of such systems. It will be followed by the energy management strategies that can be needed in some of the EMR models. Finally, several cases using EMR will be presented.

II. MODELING COMPLEX SYSTEMS

EMR aims to be great at modeling complex systems. Such systems can often be broken down in several smaller subsystems. For example, a car can roughly be seen as the association of a gas tank, an engine, a shaft and wheels. Each of these subsystems are mandatory in the management of the power flow, which is in this case from the tank to the road. The pictograms used in the EMR formalism are available in the Appendix (Fig. 15). There are four main elements that are present in the EMR to account for this type of systems.

A. The source element

The source element is where everything begins for the EMR. This can be either the energy storage (sub)system (ESS) or the environment in which the vehicle is evolving. This element has one input and one output. A few examples of source elements pictograms can be seen on Fig. 1. In particular, they are represented as green ovals and are therefore easily recognizable.

B. The conversion element

The conversion element is probably the simplest element of them all. It can be of two different types : monophysical

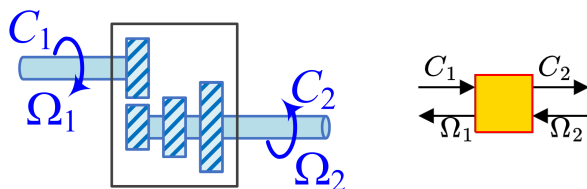

Figure 2. Examples of conversion elements in EMR formalism

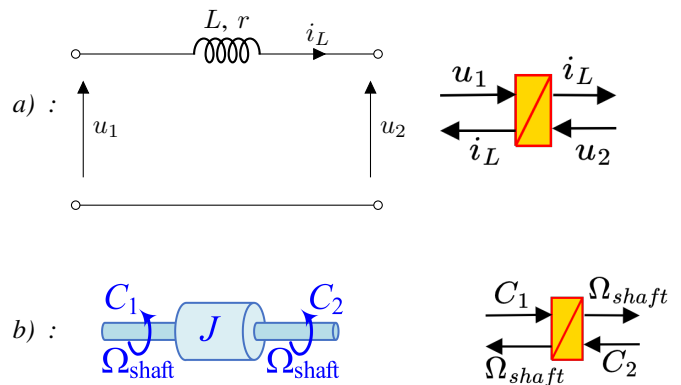

Figure 3. Examples of accumulation elements in EMR formalism : a) an inductance and b) an inertia

conversion or multiphysical conversion. In the first case, it means the energy is of the same type both in the input and the output of the block. Multiphysical conversion means the energy type is changing through the block. It can be the case for an electric motor that converts electrical energy to mechanical energy. On the contrary of the source elements, it has two inputs and two outputs. Indeed, since it both receives and gives power, it should have action and reaction paths before and after. Conversion elements can for example be a gearbox or a chopper (power electronics converter) for monophysical conversion and electric motor or engine for multiphysical conversion. An example of conversion element is given in Fig. 2.

C. The accumulation element

The accumulation element is the one where differential equations take place. Having physical relations through differential equations mean that there is a temporary energy storage. It can be the case for inductors which store magnetic energy, inertia which store kinetic energy or capacitors that store electrostatic energy. These elements, like their conversion counterparts, are represented by yellow rectangles with two inputs and two outputs. These ones, however, are crossed out by a red line. Examples of accumulation elements can be found in Fig. 3.

D. The coupling element

The coupling element, finally, is the block that is used either to merge or to divide two power flows. It happens very often in real physical systems, in cases such as the Kirchhoff's

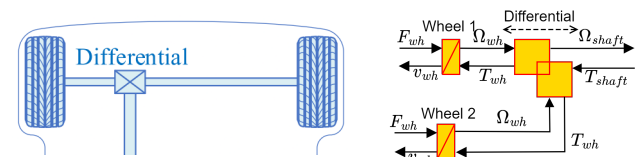

Figure 4. Examples of coupling elements in EMR formalism

current law, or the differential in a car. It is represented by overlapping yellow squares (or circles for multiphysical coupling). This has one more input and one more output than the elements presented above. They can either be on the left side or on the right side of the element, considering if the power is being divided or merging. Example of a coupling element is presented in Fig. 4. Coupling elements are often used when modeling the most complex systems, such as the multi-machines in [4] or [5]. Introducing them will imply missing equations for a control loop, and then require some mandatory strategies that will be discussed in section IV.

E. Tuning path

Once the EMR of the system is done, the tuning path can be defined. The tuning path is a chain of physical quantities, that links the variable that can be controlled to the variable that is wished to be controlled. As an example, the controlled variable in the EMR of an electric vehicle will be the duty cycle of an inverter, while it is wished to control the velocity. Therefore, after going through the chain of inversion, an action on this duty cycle will have an impact on the speed of the vehicle. It is fundamental that the tuning path is independent of the direction of the power flow.

III. CONTROL LOOP BASED ON INVERSION THEORY

One of the key aspects of EMR is that it easily allows to implement a control loop. It is done step by step by inverting every block of the modeling chain. The main principle of the inversion is represented on Fig. 5. It is starting with the latest blocks, and it goes up the modeling chain all the way to the variable that needs to be controlled. There is a different way of inverting each element of the main chain, such as, traction or electric braking of an electric vehicle.

A. Inversion of the conversion element

The conversion element are the simplest elements of the modeling chain, and are also the easiest to invert. Since they only represent instantaneous conversion, there is no differential equations. If the system equation is of the $y = K.u$ type, then the control equation will simply in the form of $u_{ref} = \frac{1}{K}.y_{ref}$. Only one input and one output are included in the control blocks, as only the quantities of the action path are considered.

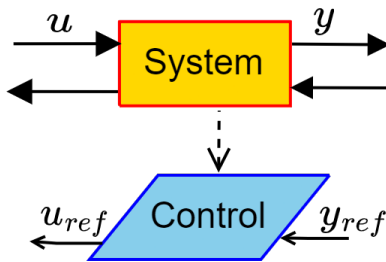

Figure 5. Inversion principle of a (sub)system

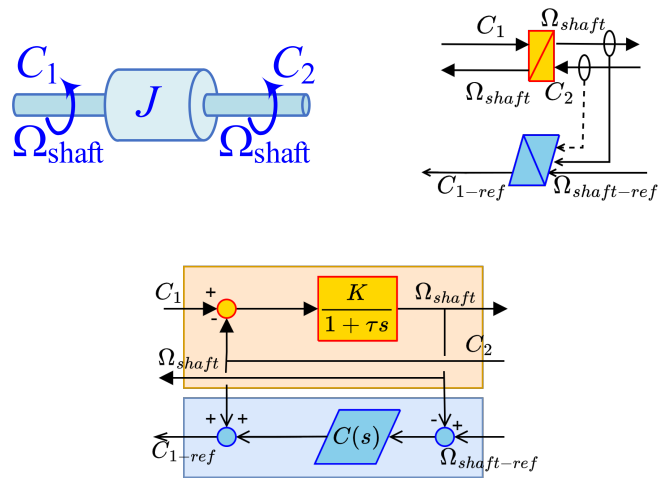

Figure 6. Example of inversion of an accumulation element using EMR formalism

B. Inversion of the accumulation element

The accumulation elements are a bit trickier. Since they represent differential equations in their causal form, its inversion cannot just be the inversion of the equation, as it would not be realistic. The inversion is then made through the use of controllers. These can be of different types, like proportional (P), proportional-integral (PI), or more advanced controllers, like non linear or advanced controllers, depending on the required performance. Here all the four links of the system will be used for maximal control structure [6]. An example with a shaft is given in Fig. 6, where C_1 and C_2 are the torques, Ω_{shaft} is the angular speed of the shaft, C_{1ref} is the reference in torque and $\Omega_{shaft-ref}$ is the reference in angular speed. In this case (that is analogous to many other physical systems), the controlled variable is the torque C_1 , through which the wished angular speed Ω_{shaft} is obtained. It is then that, with respect to the causality principle, a control C needs to be designed to inverse the accumulation element. The corresponding equation is given by :

$$C_{1-ref} = C(s)(\Omega_{shaft-ref} - \Omega_{shaft-meas}) + C_{2-meas} \quad (1)$$

where $\Omega_{shaft-meas}$ and C_{2-meas} are the measured values of Ω_{shaft} and C_2 , respectively. It is then in relation with the requirements that the controller is designed.

C. Inversion of the coupling element

The inversion of the coupling element depends on the number of signals that are controlled versus the number of signals that wish to be controlled. In the case where both these numbers are equal, no further action is needed and the inversion can take place as if it was a simple conversion element. In the case where there are more variable to control than variable that are controlled, then more equations are needed to the model and a compromise must be found. For that, the inversion of the coupling element give a new input that should be set by a strategy using a strategy pictogram.

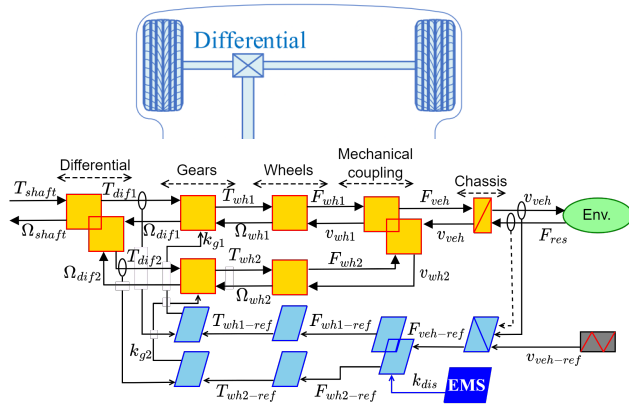

Figure 7. Examples of coupling elements in EMR formalism and the associated EMS

In this case, all the variables can not be perfectly controlled. In the last case, there are degrees of liberty induced by the structure of the coupling. It means that the variables to be controlled can have the same values with different sets of signals.

IV. ENERGY MANAGEMENT STRATEGY

In the previous section, it has been put into evidence that there are cases where external criteria appear for controlling for model. This is the case when considering the inversion of the coupling element. In these cases, the third and last main field of EMR needs to be introduced. The energy management strategies (EMS) will be mandatory to provide the extra references. Let us once again take an example, with a vehicle which has an electronically controlled differential distributing torque between the two wheels, as shown in Fig. 7. By tuning the value of the distribution factor k_{dis} , the output torque of the wheels can be chosen, while the sum of the two must remain equal to the total torque T_{shaft} . It is in that dark blue block of EMS that the decisions for the energy management strategies will be taken. In that special case, the torque can be maintained below a certain threshold to prevent wheel slipping or overspeeding. These EMS are already widely used in the context of EMR, such as in [7] or [8].

V. CASES STUDY USING EMR

The principles of EMR presented above show to be very useful for various cases, and are now widely used in several powertrain design and configuration.

A. All-wheel-drive electric vehicle

This first example will focus on an off-road electric vehicle, working with an all-wheel-drive [9]. This vehicle is an off-road vehicle, which is agile and rather limited to low speeds. Several powertrain configurations are studied, as presented on Fig. 8. The first and easiest case is shown on the left, and only includes one Li-Ion battery, with the associated electric drive. The second one allows to provide power to the back wheels separately, by using another Li-Ion battery and electric

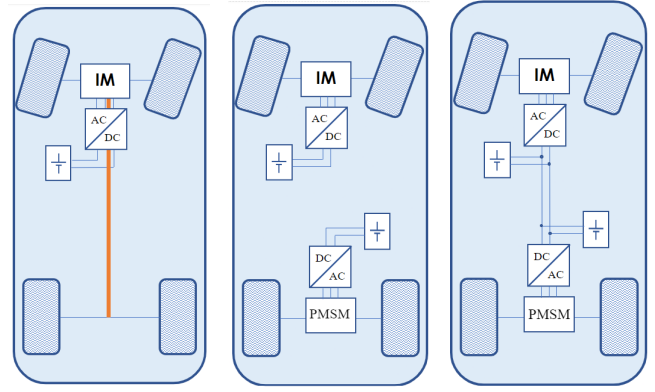

Figure 8. The different powertrain configurations of the vehicle : the original case (left), the two powertrains case (middle) and the unified powertrain case (right)

drive. At last, the third configuration links the two outputs of the batteries together, as they are now both able to provide power to the electric drives. This paper compares the efficiency of different powertrains, as well as the stress applied to the battery cells. For that analysis, the formalism of EMR is used. The equations of the first model are given on Table I. Let us take a closer look at each case. As a beginning, the EMR of the first case is shown on Fig. 9, on which the tuning path is highlighted in blue. This EMR is pretty simple as it involves only the classic elements of an electric vehicle. For the second case, its EMR is given by Fig. 10. This case really is more complex as it introduces another battery and another motor. Their apparition in the powertrain lead to a second chain on the EMR, merging with the first one only when the resistive forces of the environment are considered. This merge brings a mandatory coupling element, defined by eq. 2.

$$\begin{cases} F_{veh} = F_{wh-f} + F_{wh-r} \\ v_{veh} = v_{wh-f} + v_{wh-r} \end{cases} \quad (2)$$

where F_{wh} are the forces applies on the wheels, with the subletter f corresponding to the front wheels and r corresponding to the rear wheels. Its inversion needs to be introduced as well :

$$\begin{cases} F_{wh-f-ref} = F_{veh-ref} k_{dis} \\ F_{wh-r-ref} = F_{veh-ref} (1 - k_{dis}) \end{cases} \quad (3)$$

where k_{dis} is a splitting factor that comes from the mandatory EMS. This EMS will aim to split the torque in the best way possible to improve the efficiency of the overall

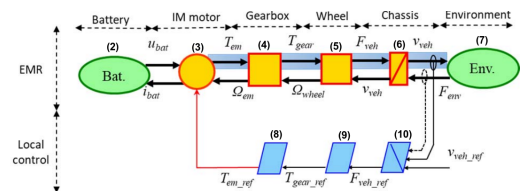

Figure 9. EMR of the first case

TABLE I
CASE I - EQUATIONS FOR MODELING AND CONTROL

Modeling	
$\begin{cases} u_{bat} = u_{ocv}(SoC) - r_{bat}i_{bat} \\ SoC = 100\% \left(1 - \frac{1}{C_{bat}} \int i_{bat} dt\right) \end{cases}$	(4)
$\begin{cases} T_{em} = T_{em-ref} \\ i_{mot} = \frac{T_{em}\Omega_{em}}{u_{bat}\eta_{em}^k} \end{cases} \text{ where } k = \begin{cases} 1 & \text{if } T_{em}\Omega_{em} \geq 0 \\ -1 & \text{if } T_{em}\Omega_{em} < 0 \end{cases}$	(5)
$\begin{cases} T_{gear} = k_{gear}T_{em} \\ \Omega_{em} = k_{gear}\Omega_{wheel} \end{cases}$	(6)
$\begin{cases} F_{veh} = \frac{T_{shaft}}{R_{wheel}} \\ \Omega_{wheel} = \frac{v_{veh}}{R_{wheel}} \end{cases}$	(7)
$v_{veh} = \frac{1}{M_{veh}} \int (F_{veh} - F_{env}) dt$	(8)
$F_{res} = f_{roll}M_{veh}g + \frac{1}{2}\rho C_x A (v_{veh} + v_{wind})^2$	(9)
Control	
$T_{em-ref} = \frac{T_{gear-ref}}{k_{gear}}$	(10)
$T_{gear-ref} = R_{wheel}F_{wh-ref}$	(11)
$F_{veh-ref} = F_{env-meas} + C_{veh}(s)(v_{veh-ref} - v_{veh-meas})$	(12)

power chain. As the two motors considered are of different types (induction machine and permanent magnet synchronous motor), their efficiency maps are clearly distinct as well. It is why having a performing EMS is crucial here. When comparing the efficiency maps of the two motors presented in Fig. 12, it can be observed that the PMSM offers a better efficiency with speeds that are between 1800rpm and 4500rpm. The induction machine efficiency is better outside of these speed values. Now, a simple EMS is to affect the whole torque to the PMSM inside that range, while letting the IM work otherwise. Finally, the EMR of the third case is presented

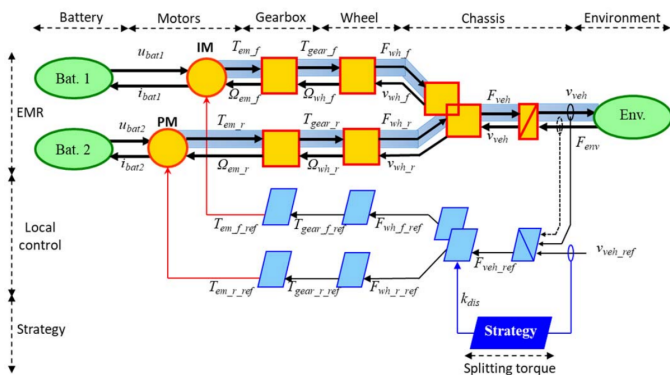

Figure 10. EMR of the second case

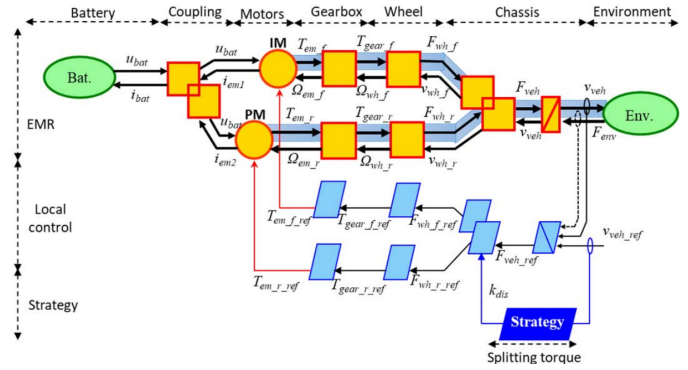

Figure 11. EMR of the third case

on Fig. 11. This one is also widely different, as this electrical circuit is unified and it is the mechanical subsystems that are split. To unify the electrical circuit, the DC bus is made common. There is only one source element representing one battery as having two battery packs is equivalent to having a single battery pack doubling the number of cells in parallel. Then there are two different mechanical power chains, one for the front wheels and one for the back wheels. They then merge also when the environment forces are considered. In a way similar to the second case, an EMS needs to be introduced to split the torque between the two motors. For each one of these three cases, EMR show to be very useful to model complex systems by representing only the macroscopic quantities. The control loop also offers a simple graphical method to convert the speed setpoint into a torque setpoint by inverting every subsystem. Finally, the EMS was mandatory to have a rule splitting the torques. Once this whole model is settled, it gets easier to run simulations (mainly in Matlab/Simulink®). In this paper, simulations were run using a WLTC driving cycle in order to observe the responses in the efficiency of the system and the current that went through the battery. It helped to conclude that the two-motors configurations helped increasing the efficiency while having two battery packs significantly reduced the current (and therefore the stress) applied to battery cells.

B. Multi-motors electric vehicle

This second example will take a closer look on the application of EMR for a multi-motors electric vehicle [10]. The vehicle in this study is a Formule SAE-type vehicle, with four wheels independently driven by four associated motors.

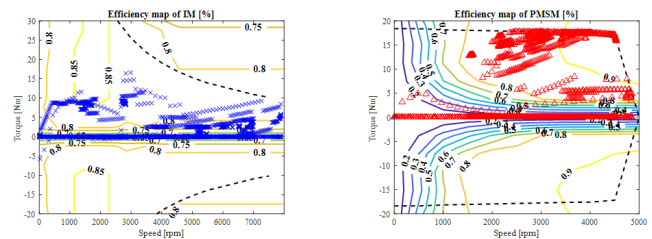

Figure 12. Efficiency maps of the IM (left) and PMSM (right) [9]

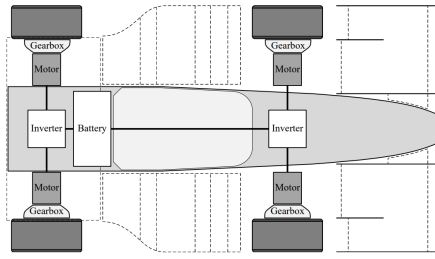

Figure. 13. Detailed powertrain of the multi-motors Formule SAE

Its powertrain is detailed on Fig. 13. Having four different motors will imply a coupling element with four couples of outputs (actions & reactions). The EMR of this vehicle is presented on Fig. 14. Here, only the path leading to one motor is represented, as the ones for the other motors are the same. Other coupling elements are also present at the end of the power chain. One of them is here to have two distinct source elements to represent the environment, as the resistances of the road and the air are separated. The other one is acting as a merge, as there is only one total force applied by the air to the vehicle. This is why the total forces of each wheel are reunited here. In the same way as the case before, the inversion of the coupling element for the wheels needs a strategy to distribute the torque to each wheel. In this paper, this is an opportunity to both prevent wheel slip and improve energy management. A three layer control system is used, which features a disturbance observer to compensate the uncertainties. An optimization problem is also here to determine the ideal value of torque to apply to each wheel. Finally, there is a controller to make the real output speed follow the reference.

VI. CONCLUSION

In this paper, the principles of the energy macroscopic representation were presented and they were followed by a detailed description of its graphical formalism. They showed to be a great tool for modeling complex systems and highlighting macroscopic interactions. The structure of EMR is also adapted for having precise control loops, and energy management strategies are quickly integrated into the whole model. These energy management strategies can be of very different natures, and show to be useful for many applications. This work focused mainly on electric vehicles applications, and gave clear academic examples of how EMR can be a major tool of electrical engineering.

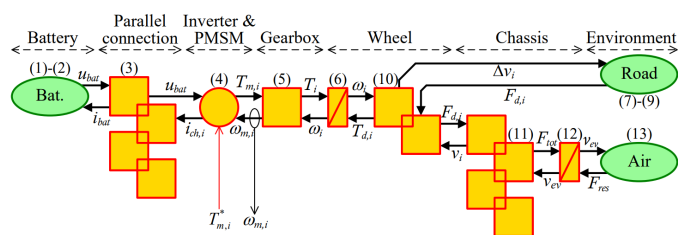

Figure. 14. EMR of the multi-motors FSAE

ACKNOWLEDGEMENTS

This work was supported in part by Grant 950-230672 from Canada Research Chairs Program, in part by Grant RGPIN-2017-05924 from the Natural Sciences and Engineering Research Council of Canada.

REFERENCES

- [1] Alain Bouscayrol and Betty Lemaire-Semail. "Energetic macroscopic representation and inversion-based control". In: (2022).
- [2] David Ramsey, Alain Bouscayrol, and Loic Boulon. "Energy Consumption of a Battery Electric Vehicle in Winter Considering Preheating: Tradeoff Between Improved Performance and Total Energy Consumption". In: *IEEE Vehicular Technology Magazine* 17.3 (2022), pp. 104–112.
- [3] *L2EP, Control Group, EMRwebsite*. <http://www.emr-website.univ-lille.fr/>. Accessed: 2023-02-05.
- [4] Kaibo Li et al. "A Hybrid Modular Cascade Machines System for Electric Vehicles Using Induction Machine and Permanent Magnet Synchronous Machine". In: *IEEE Transactions on Vehicular Technology* 70 (1 2021). ISSN: 19399359.
- [5] Bao Huy Nguyen et al. "Optimal energy management of a parallel hybrid truck for fuel consumption comparative study". In: vol. 2018-June. 2018.
- [6] A. Bouscayrol, Ph Delarue, and X. Guillaud. "Power strategies for maximum control structure of a wind energy conversion system with a synchronous machine". In: *Renewable Energy* 30 (15 2005). ISSN: 09601481.
- [7] Abdoulaye Pam et al. "Comparison of different models for energy management strategy design of a parallel hybrid electric vehicle: Impact of the rotating masses". In: *IET Electrical Systems in Transportation* 11 (1 2021). ISSN: 20429746.
- [8] Bao Huy Nguyen et al. "Real-time energy management of parallel hybrid electric vehicles using linear quadratic regulation". In: *Energies* 13 (21 2020). ISSN: 19961073.
- [9] Chi T.P. Nguyen et al. "Powertrain analysis of an all-wheel-drive off-road electric vehicle". In: 2019.
- [10] Minh C Ta et al. "Four-wheel Independently Driven Formula: Experimental EV for Motion Control Studies". In: *2022 IEEE Energy Conversion Congress and Exposition (ECCE)*. IEEE, 2022, pp. 1–8.

APPENDIX

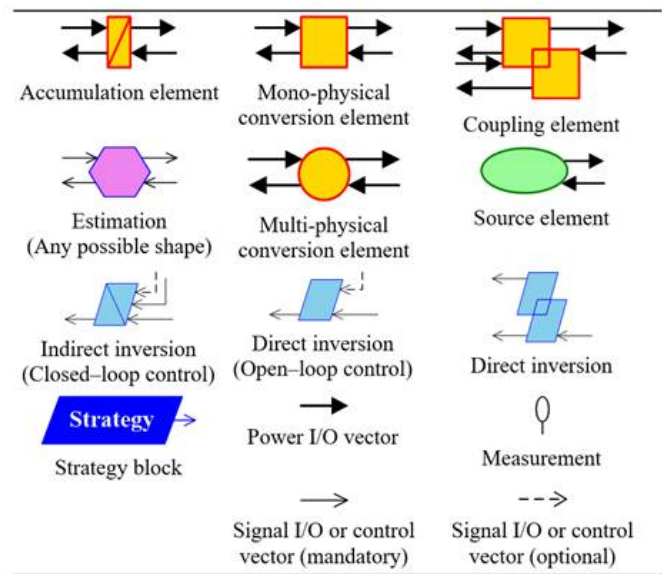

Figure. 15. EMR pictograms