

We are IntechOpen, the world's leading publisher of Open Access books Built by scientists, for scientists

6,600

Open access books available

178,000

International authors and editors

195M

Downloads

Our authors are among the

154

Countries delivered to

TOP 1%

most cited scientists

12.2%

Contributors from top 500 universities



WEB OF SCIENCE™

Selection of our books indexed in the Book Citation Index
in Web of Science™ Core Collection (BKCI)

Interested in publishing with us?
Contact book.department@intechopen.com

Numbers displayed above are based on latest data collected.
For more information visit www.intechopen.com



Chapter

Review on Glass Curtain Walls under Different Dynamic Mechanical Loads: Regulations, Experimental Methods and Numerical Tools

Mohammad Momeni and Chiara Bedon

Abstract

This chapter explores the behaviour and performance of glass curtain wall systems under various dynamic mechanical loads, including seismic, wind and impulsive loads. The classification of glass facade systems, comprising framed and frameless types, is first shortly discussed, along with their core components such as glass panels and frames. The challenges posed by glass material, including its vulnerability to impact, stress peaks and extreme loads, are acknowledged. The study further delves into various design standards and regulations for glass facade systems under dynamic loads, addressing seismic events and wind and impulsive loads and hence outlining parameters for assessment, performance criteria, and design considerations in use of glass curtain walls. Additionally, numerical methods are explored as effective tools for simulating and analysing the mechanical response of glass curtain walls under dynamic loads. The utility of these methods is showcased through a case study involving the Finite Element (FE) modelling of a glass curtain wall system exposed to a lateral in-plane load. The results of FE analysis are then compared with literature experimental results, which indicates its capacity to anticipate structural responses and even complex mechanisms under dynamic loads.

Keywords: glass curtain walls, dynamic loads, finite element models, experiments, regulations

1. Introduction

In modern structural and architectural design of buildings, glass curtain wall (CW) systems have emerged as a defining building feature that brings aesthetics as well as functionality for specific purposes. These non-structural systems consist of assemblies of glass panels supported by metal structures, which are connected to the main

building through special connectors. Due to the relatively low tensile strength and brittle nature of glass as a load-bearing material in these systems, and with an increasing use of these systems in building designs, understanding their behaviour under various loads becomes important. This paper presents a review that explores the assessment of glass CW systems under different loads, including seismic, wind and impulsive loads. The first part of this paper looks into the fundamental principles of glass CW systems, distinguishing between framed and frameless configurations. The next parts delve into the realm of dynamic loads, encompassing seismic events, wind and impulsive loads such as blast and impact. The vulnerabilities and challenges posed by the glass material are then discussed, highlighting the need to address its relatively low tensile strength and susceptibility to brittle fracture. To this aim, an extensive review of available design standards for glass facade systems under dynamic loads as well as the classification of glass material based on their production methods is presented. The exploration of various design standards and codes underscores the collective efforts to ensure the resilience of these systems in the face of various dynamic forces. The utilisation of static and dynamic racking tests, wind tunnel experiments, shock tube tests and impact assessments elucidates the methodology behind ensuring the performance and safety of glass CW systems under dynamic loads. Moving beyond standards, the paper unfolds numerical methods that emerge as crucial tools for assessing structural responses under dynamic loads. Recognising the limitations and complexities of laboratory experiments, the significance of numerical methods, particularly finite element analysis, in comprehending the behaviour of glass CW systems under dynamic loading is also discussed. To validate the accuracy of numerical methods, an illustrative example of a finite element model is presented to evaluate the behaviour of a dry-glazed CW system under lateral in-plane loading.

2. Glass CW technology

A CW is a peripheral structure for buildings, which is composed – in most of cases - of metal supporting structures (aluminium or steel frame members) and plates (which can be composed of glass, aluminium, slate, ceramics, sandwich panels, etc.). When the panel is made of glass, as it is for CWs major functions of load-bearing capacity and architectural impact are expected. The classification of glass facade systems is based on their structural support, hence resulting in two main types: framed or frameless glass facade systems. Framed systems are typically designed using extruded aluminium components, although earlier versions used steel. On the other hand, frameless systems are restrained using bolted spider arms and steel supports, which serve as crucial architectural elements blending stability and aesthetic impact. The metal frames offer an efficient point support for glass panels but include various point-fixed joint options for truss and cable-supported systems. In these cases, typical systems comprise four key components: glass panels, bolted fixtures, glass support attachments (spider arms) and the main structural support frame [1]. Examples of framed and frameless glass facades are shown in **Figure 1**.

In this context, it is worth to remind that a glass CW represents a non-structural, exterior wall system that is used to clad buildings [2]. It is designed to separate the interior environment of a building from the external space while allowing light to enter and providing an important aesthetic appearance. Unlike more solid alternatives such as masonry, CWs are notably lightweight solutions of large use in modern

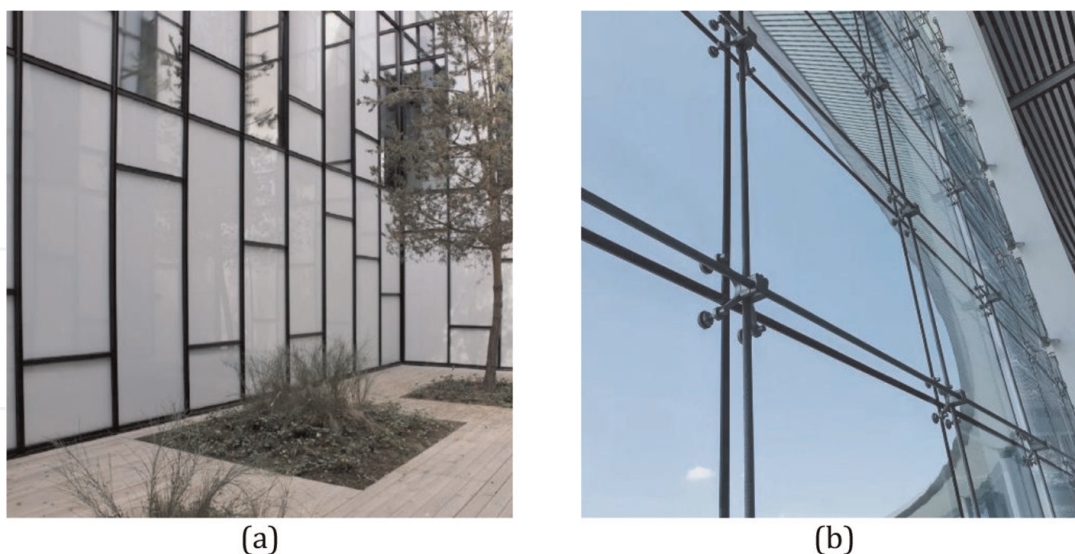

Figure 1.
Examples of glass facade; (a) framed glass facade, and (b) frameless glass facade.

constructions and derive their name from the resemblance to hanging curtains. Glass CW systems come then in two main forms: stick-built and unitised solutions, each with distinct structural attributes [3]. Stick-built systems involve on-site assembly of framing and glazing components, while unitised systems are typically pre-fabricated into CW units before installation. These constructional methods and technologies result in varying mullion-to-transom joints, where stick-built systems use aluminium shear blocks and unitised systems rely on direct screw connections. The unitised version also employs specific mullion profiles for easier on-site assembly and improved drift capacities under in-plane lateral loads, compared to stick-built systems. The choice between dry-glazed and structural sealant-glazed (SSG) configurations for glass panels is another parameter that further influences the mechanical performance of the assembled system [3]. Dry-glazed systems utilise rubber gaskets for compression, water resistance, and air infiltration prevention, while SSG systems are based on structural sealants to enhance water intrusion resistance and restrict the movement of glass panels. In addition, anchorage attachments play also a significant role, which is mostly influenced by factors like span lengths, temperature fluctuations, design loads and considerations for seismic or wind events and determining the size, shape and placement of attachment anchors. These attachments lead unavoidably to diverse responses during wind and seismic events, accommodating movements and rotations while maintaining flexibility. Overall, the interplay of these assembled components largely shapes and governs the complex behaviour of glass CW systems, underscoring the need for comprehensive engineering analysis, thoughtful design and construction considerations.

3. Glass material

The utilisation of glass in constructing envelopes has garnered substantial attention from researchers in recent decades [4]. However, it is important to remind that glass itself, despite its prevalent mechanical use, still poses challenges when overloaded, due to its relatively low tensile strength and brittle nature. This becomes particularly

evident in the context of glazing windows and facades, which constitute delicate and breakable elements within a building structure. This vulnerability is especially pronounced when the design anticipates extreme loading conditions or the potential for such conditions arising over the structure's lifespan, as these glass envelopes serve as the primary barrier between the interior and exterior environments [5]. Finally, it is important to emphasise that glass components are the most vulnerable component in these systems, but an optimal structural design should pay attention for many other CW components [3]. With a focus on glass material, common types are classified based on their production methods into three categories [6]. AN glass material stands out for its cost-effectiveness due to its relatively straightforward production process. However, in terms of strength, it lags behind HS and FT glasses. Through the method of heating and gradual cooling used to transform AN glass, HS glass is formed, which is characterised by a certain surface compression within the glass panels. This results in a significant strength boost, compared to AN glass, and approximately doubles its strength. This arises from the harmonious distribution of thermal strains across the glass thickness during the heating and cooling phases, leading to a surface compressive stress raising up to about 30 MPa. On the other hand, elevating AN glass temperature to around 700°C and rapidly cooling it generates FT glass. In this case, the surface compression stress is notably high, exceeding 69 MPa as per ASTM C1048 standard [7]. This remarkable surface compression endows FT glass with a strength that is about 4 to 5 times greater than AN glass. Unlike AN and HS glasses, FT glass possesses stored elastic energy. Consequently, when broken, it fragments into numerous small, fine glass cubes (**Figure 2**). This unique behaviour is responsible for FT glass being commonly referred to as “safety glass” [8]. Worth noting is that under circumstances involving high-strain rate loads like explosions or impacts, FT glass, despite its safety characteristics, does hold the potential to break into larger pieces.

It should be noted that research studies and regulations emphasise the remarkable strength of glass material under high strain rate loads, with a dynamic increase factor of approximately 1.78, resulting in a compressive strength of 80 MPa for glass when subjected to impact or explosion [9, 10].

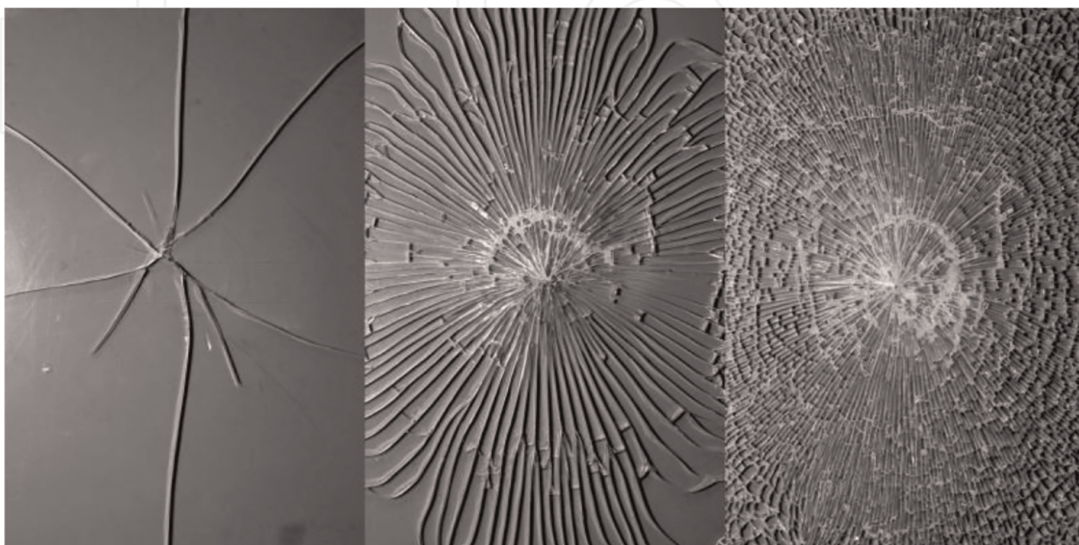

Figure 2. Fracture pattern in AN (left), HS (middle), FT (right) glass material [8].

4. Selection of design standards and experimental protocols for glass facades under dynamic loads

Dynamic loads refer to forces that fluctuate in strength and direction over time. Such loads stem from sources like earthquakes, explosions, impacts, and sudden shifts in motion. They can induce extra stress on structures, materials, and components, necessitating their consideration during engineering and design to prevent fatigue, resonance, and other dynamic effects. In recent decades, significant events have caused substantial consequences for buildings and their envelopes. Notably, major earthquakes like the 1995 Northridge Earthquake prompted professionals to delve into improved glazing system design for enhanced safety, where the damage of glass facades was extensively observed, and more than 60% of the panes were broken [11]. Furthermore, recent explosion incidents have amplified the need for designing blast-resistant buildings, particularly those featuring CWs, to safeguard occupants from external explosions. Regrettably, many of these events have led to casualties, injuries and substantial financial losses, underscoring our built environment vulnerability (i.e. explosions in Tarragona, Spain 2020 [12], and Beirut, Lebanon in 2020 [13]). This underscores the necessity of considering blast loads when designing structures with CWs located near such facilities. Conversely, other loading types, such as wind and fire, should also be accounted for in glass CW design. It is worth noting that in areas with high wind velocities, wind governs the structure design, requiring the entire glass CW and its connections to withstand wind loads. Consequently, these components (i.e. glass CWs) typically face a multi-risk environment, subject to different types of loading as given above, and have often incurred significant damage, posing threats to life safety and incurring economic losses due to repair expenses and downtime.

4.1 Seismic events

During seismic events, the glass panels within the CW framing system experience in-plane displacement due to increasing story drift from the seismic forces. As stated in ASCE 7-16 [14], engineers are obligated to ensure that the relative seismic displacement (drift) of a considered glass CW component, D_{pI} , remains below the relative seismic displacement at which glass fallout from the CW, storefront, or partition occurs. This means that $\Delta_{fallout}$, as presented in Eq. 1, should respect the condition:

$$\Delta_{fallout} \geq \max \{ 1.25D_{pI}, 13mm \} \quad (1)$$

It should be also noted that $D_{pI} = D_p I_e$, where D_p is the relative seismic displacement that the component must be designed to accommodate, and I_e is the importance factor (1.00, 1.25, 1.50 for increasing importance). However, there are some exceptions in ASCE 7-16 to describe states that do not comply with this requirement. In this regard, glass panels with sufficient gap from the frame, such that physical contact does not occur at the design drift do not need to satisfy Eq. 1. Instead, the focus shifts to meeting the following criteria:

$$D_{clear} \geq 1.25D_{pI} \quad (2)$$

where D_{clear} signifies the relative seismic displacement at initial glass-to-frame contact. For rectangular glass panels, D_{clear} is determined by Eq. 3 as follows:

$$D_{clear} \geq 2c_1 \left(1 + \frac{h_p}{b_p} \frac{c_2}{c_1} \right) \quad (3)$$

where the rectangular glass panel height and width are denoted by h_p and b_p , respectively, and c_1 and c_2 represent the clearances between the frame and the vertical and horizontal edges of the glass, respectively. These parameters are shown in **Figure 3**.

As many other national and international standards for structural design, ASCE 7-16 uses “risk categories” to find an appropriate design wind velocity for determining the corresponding pressures and thus design structures and building components [14]. In this context, fully tempered monolithic glass in risk categories I, II and III and located within 3 m of a walking surface is exempt. Also, annealed or heat-strengthened laminated glass with an interlayer of at least 0.76 mm, mechanically captured in a wall system glazing pocket and secured to the frame by a wet-glazed elastomeric sealant perimeter bead (minimum 13 mm glass contact width), or an approved anchorage system, is not subjected to this requirement. It should be noted that different global codes present diverse performance criteria for CWs [16]. Eurocode 8 [17] offers permissible inter storey drift ratio values for damage control in non-structural elements under various conditions: 0.5%, 0.75% and 1% for brittle non-structural elements attached to the structure and for ductile non-structural elements or those integrated without obstructing structural deformation, respectively. New Zealand standard for structural design actions, NZS 1170.5 [18], dictates that a glass CW is considered to have failed when the relative displacement attains the larger of

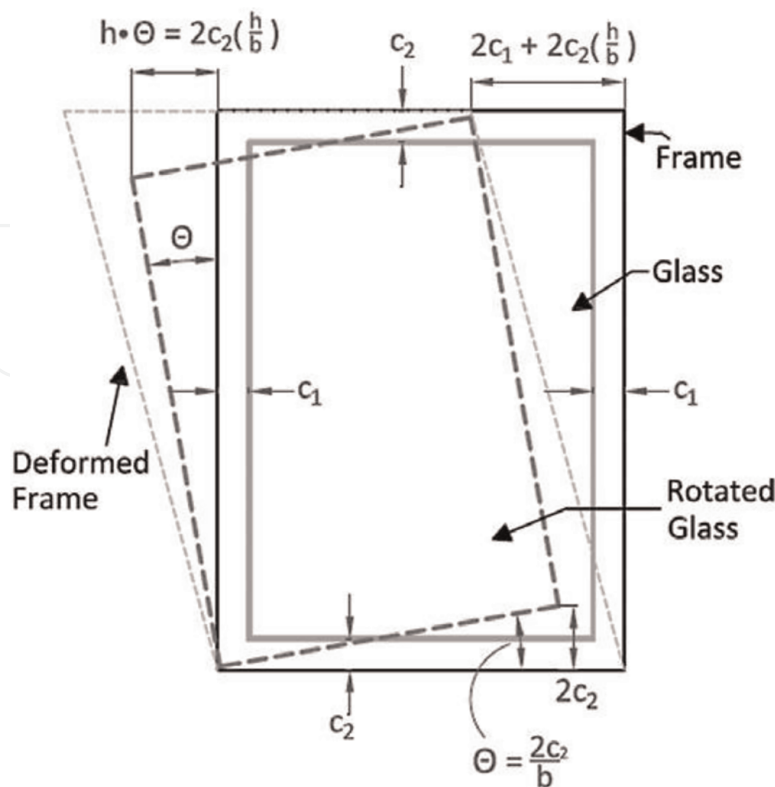

Figure 3. Illustration of geometric parameters to determine drift at initial glass-to-frame contact [15].

two values: either 1/250 of the span or twice the width of the glass clearance. Here, the span represents the height of the story for the CWs attached to the building, while the glass clearance corresponds to the width of the silicone adhesive bar inserted on each side of the glass panel. In FEMA 273 [19], diverse configurations of glazing systems involve subframes attached to the main structure, either field-assembled or prefabricated. These systems are sensitive to deformations, and drift analysis is crucial to ensure compliance with performance levels. Failures, particularly in dry glazing, can result in shattering or detachment. Visual evaluation encompasses factors like glass support, mullion arrangement, sealants and connectors. Acceptance criteria revolve around force provisions and displacement for varying levels, with drift limits set at 0.02 and 0.01 for Life Safety and Immediate Occupancy performance levels, respectively. In FEMA P-58-2 [20–22], a fragility class is assigned to each category of glass CW, serving as a valuable point of reference for seismic design and calculations. In other words, FEMA P-58 employs repair costs instead of structural parameters to assess seismic performance. Fragility and repair cost functions are linked to vulnerable building components, showing the probability of surpassing damage thresholds at specific engineering demand parameter values. These functions, combined with peak structural responses, predict damage states and estimate economic losses. Other codes such as Chinese [23, 24], Canadian [25] and Japanese [26] establish varying limits tied to earthquake load intensity. In Chinese design codes [23, 24] for CWs, a distinct recommendation is presented. It stipulates that the in-plane peak drift of the CW should exceed three times the elastic deformation limit of the main structure. The Canadian code [25] assigns a value of 0.02 applicable to all structural types, which is a conservative approach across various building categories. It is understood that the glass panel loses its functionality immediately upon breakage. As per the Japanese code [26], glazed systems must be designed to adhere to inter storey drift ratio limits of 1% for severe earthquakes, 0.5% for moderate earthquakes, and 0.33% for low earthquakes. While the international codes' approaches mentioned above pertain to seismic requirements for glass CWs, the challenge persists in evaluating the CWs' capacity under various limit states. Generally, the codes emphasise the necessity of conducting experimental tests to address this concern. In the following, existing experimental tests to determine the lateral capacity of CW under seismic loading are discussed.

To evaluate the seismic performance of CW systems, various experimental protocols including shaking table test, in-plane racking test and so on can be found in the literature. These protocols serve as essential tools in understanding the dynamic behaviour of CW systems and contribute to more resilient and reliable structural designs. Shaking table testing stands as a foundational approach in assessing the seismic performance of CW systems. This technique involves subjecting scaled models or prototypes to simulated seismic motions, enabling insights into dynamic properties, system responses and failure modes under controlled conditions. Standardised codes such as AC156 [27] establish guidelines for seismic qualification tests of non-structural components and systems, which are adaptable for glass CW systems meeting specific criteria (i.e. systems with fundamental frequencies greater than 1.3 Hz). Similarly, FEMA 461 [28] guides the fragility evaluation of systems sensitive to dynamic motion. Despite not being explicitly tailored for shaking table testing of CWs affixed to buildings with multiple attachment points at neighbouring floor levels, this protocol nonetheless offers valuable insights into the testing of such CW systems. In-plane racking test serves as a pivotal method to assess the drift capacity of glass CW systems under dynamic loads. Standards like AAMA 501.4 [29]

and AAMA 501.6 [30] focus on the in-plane draft capacity of framed glass facade systems as shown in **Figure 4**, offering methods for both static and dynamic testing. In AAMA 501.4, a horizontal static monotonic displacement is applied to the glass CW specimen up to a designated displacement. This facilitates the assessment of serviceability limit states, including factors like air infiltration, water penetration and structural integrity.

The second procedure, AAMA 501.6, takes a dynamic approach by subjecting the glass CW system to cyclic horizontal forces. This dynamic assessment, conducted with incremental concatenated sine waves following a crescendo pattern as depicted in **Figure 5**, mimics the stress dynamics experienced during seismic events. According to the protocol (more details about the incremental step loads can be found in [15]), the crescendo test should continue until one of these conditions is met: (1) a glass piece with an area of at least 645 mm^2 falls out, (2) the drift index (defined as the lateral displacement at the top of the glass panel divided by the glass panel height) is equal to or exceeds 0.1 (equivalent to 10%) or (3) a maximum racking displacement of

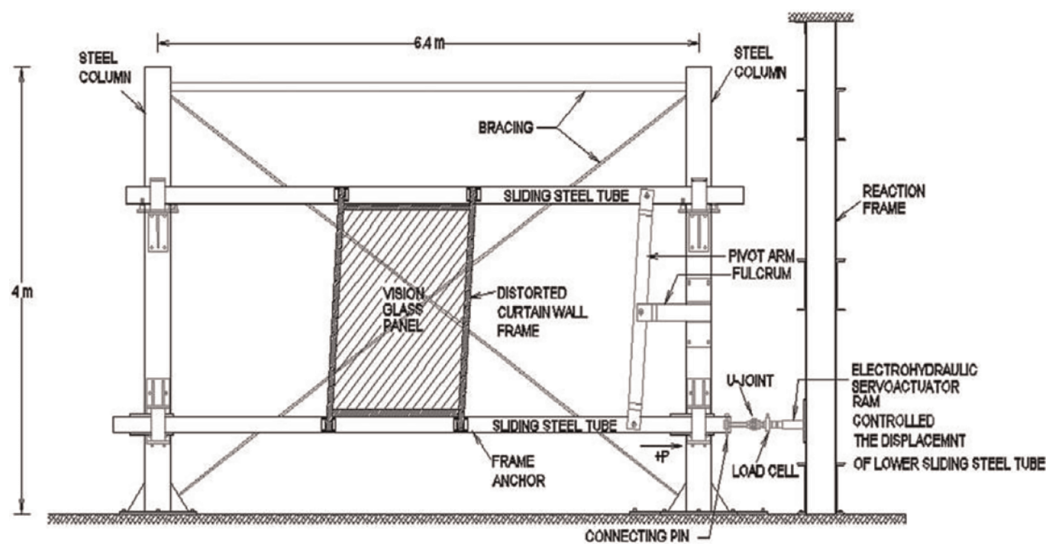

Figure 4. Schematic drawing of racking test facility designed for mock-up of glass CWs [15].

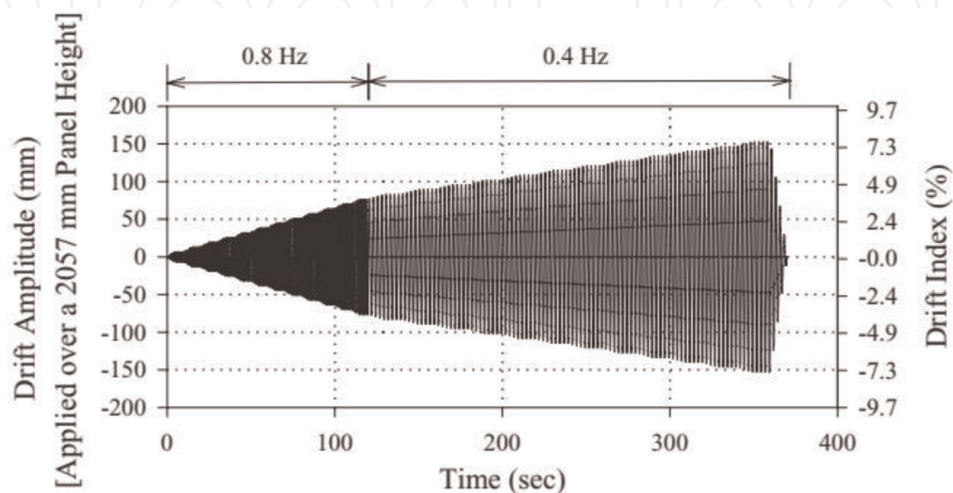

Figure 5. Standard time-dependent drift pattern for AAMA 501.6 dynamic racking crescendo test.

152.4 mm is reached. These criteria determine when the test concludes. In the case of condition (1), the displacement at which the glass fallout transpires is designated as $\Delta_{fallout}$.

By obtaining this dynamic data and incorporating it within the equations supplied by ASCE 7-16, as explained earlier, one can establish the system capacity to withstand seismic forces while adhering to specific relative drift limits.

4.2 Wind load

Eurocode 1 [31] outlines wind load calculations for facades in part 1–4, aiding structural design for buildings up to 200 m tall and to bridges having no span greater than 200 m. Wind forces are specified for the entire structure and components like cladding units. As a convention, the fundamental basic wind velocity is the 10-minute mean wind velocity with a return period of 50 years. It should be noted that traditional buildings have experienced extreme weather events, revealing the inadequacy of the current guidance, where the design values often fall below actual wind loads observed over decades, as reported in [5] for many regions of Europe, the US, as well as the Asia-Pacific region. On the other hand, many instances still exist where the code fails to offer satisfactory answers. For such situations, wind tunnel experiments or, in exceptional cases, full-scale experiments can provide solutions [32]. Wind tunnel experiments serve as an alternative to codes of practice when dealing with scenarios beyond their scope or when a more precise assessment of wind loading is deemed essential. Within a wind tunnel, the wind, the structure, its environment and occasionally its actions are replicated at a reduced scale. This allows for the measurement of wind speeds, pressures, forces, moments, accelerations and so on. Common test protocols are used to evaluate the performance of glass CWs against out-of-plane loads and weather conditions, both in laboratory and field settings. These protocols, such as ASTM E283 [33], E330/330 M [34], E331 [35], E783 [36], E997 [37] and E1996 [38], cover various aspects including air leakage, structural performance, water penetration, glass breakage probability and impact resistance. These tests are conducted using an air pressurised test chamber as can be seen in **Figure 6** for both glass CW specimens and structural glass panels. Controlled air pressure differentials simulate wind pressures, both static and cyclic, along with additional conditions like debris impacts and water pressures. These conditions aim to replicate realistic scenarios during windstorms.

It is worth mentioning that the design of glass CWs is an open-ended process, requiring engineers to consult various design guides for handling out-of-plane

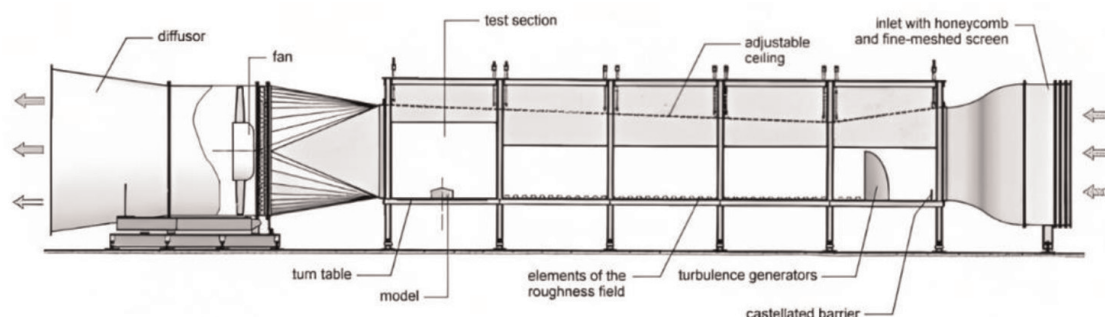

Figure 6. Schematic of wind tunnel test of the Ruhr University in Bochum, Germany [39].

loading. In addition, the conjunction of wind load with other climate changes like rain [40], hail [41], flood [42] and so on often negatively affects building facades' performance and durability. This includes surface material degradation, frost damage, salt efflorescence, structural cracking, interior harm, and other concerns, and hence, careful consideration should be taken into account for these aspects.

4.3 Impulsive loads

Impulsive loads are sudden and high-intensity forces or pressures applied to a structure within a short duration. These loads can result from events like explosions, impacts or other abrupt occurrences. Impulsive loads are characterised by their rapid rise in force and are typically short-lived but can exert significant stress on the structure [43–45]. Examples of impulsive loads include the shockwaves from explosions, the impact of heavy objects on a surface or the force exerted during a sudden collision. Due to the abrupt nature and intensity of an impulsive load, it can lead to structural damage, material deformation and even failure if not adequately considered in design and engineering. Engineers often need to account for impulsive loads when designing structures and their envelopes that are prone to encountering these sudden and high-energy events [46]. Mitigating the effects of impulsive loads requires careful analysis, materials selection and structural design that can absorb or distribute the impact forces effectively. It is important to note that a majority of casualties resulting from a blast incident are linked to injuries caused by glass fragments [5]. Therefore, extra caution should be exercised when considering glass facades in blast-prone scenarios.

4.3.1 Blast load

The progress in blast protection design achieved during the Second World War resulted in the release of an engineering manual by the United States Army Corps Of Engineers, which is labelled as UFC 3–340-02 [47] after many revisions, and it is widely used by researchers in the field of blast-resistant structures. The manual outlines blast parameter calculation and design techniques for protective construction in facilities involving explosive materials. Its strategies can be adapted for various types of structures directly, or by modifying via experimentation and numerical analyses. Notably, Section 6-27 of this manual focuses on designing glass panes under explosive conditions, providing instructions and graphs based on panel dimensions (thickness, width and height), time duration and blast pressure. These graphical representations are derived to aid in designing and assessing glazing ability to withstand prescribed blast loads with a failure probability not exceeding 0.001. Failure is assumed when maximum deflection of pane exceeds ten times the glazing thickness, preventing edge disengagement of the plate while staying within Von Kármán plate equation limits. In addition, further explanations are given in this manual as design criteria for the glass facades specifically for sealants, gaskets, beads, glazing setting, frame loads and rebound (which is the response to the dynamic loading will cause the window to rebound (outward deflection) after its initial positive (inward) deflection). The most important criteria as maximum allowable limits for frame design are: i) Frame members' relative displacement should be limited to the smaller of 1/264th of the span or 1/8 inch; ii) Maximum stress in any member and fastener should not exceed material yield stress divided by 1.65 and 2.00, respectively, and iii) The deflection of the building should not impose deflections on the frame greater than 1/264th of the length of the pane edge. Also, other codes such as HOSDB, 1997 [48]; GSA TS-01 [49]; ASTM

F1642 [50] and ISO 16933 [51] can be found in the literature regarding glazing systems subject to air blast loadings.

It is important to emphasise that the conventional regulations and building guidelines do not adequately address potential threats that could arise, such as explosive incidents. In order to ensure the protection of constructed infrastructure, there is a need to develop methodologies that can effectively quantify the capacity of structural elements to withstand explosive loads. Additionally, assessing the risks associated with the failure of these elements is crucial. To achieve these goals, a combination of experimental studies and numerical approaches is essential. This combined effort will not only provide practical solutions but also equip engineers with decision-making tools to enhance the security of vital infrastructure. In the realm of testing the blast resistance of glazing materials, two primary methods are commonly employed: shock tube [52] and arena test [51]. Shock tubes are capable of generating relatively moderate pressures over extended durations, making them well-suited for assessing the effects of larger-scale explosive devices, such as vehicle-borne improvised devices and industrial explosions. Conversely, arena tests simulate scenarios involving smaller charges detonated at close range or vehicle-borne improvised explosive devices. Examples of shock tube testing and arena testing of full glass windows under blast loading can be seen in **Figure 7**. It is noteworthy that variations in design codes need to be considered when designing building facades to withstand blast events. In this regard, a comprehensive analysis was conducted to compare the different existing standards for testing blast-resistant windows and glazing materials, as referenced as [55].

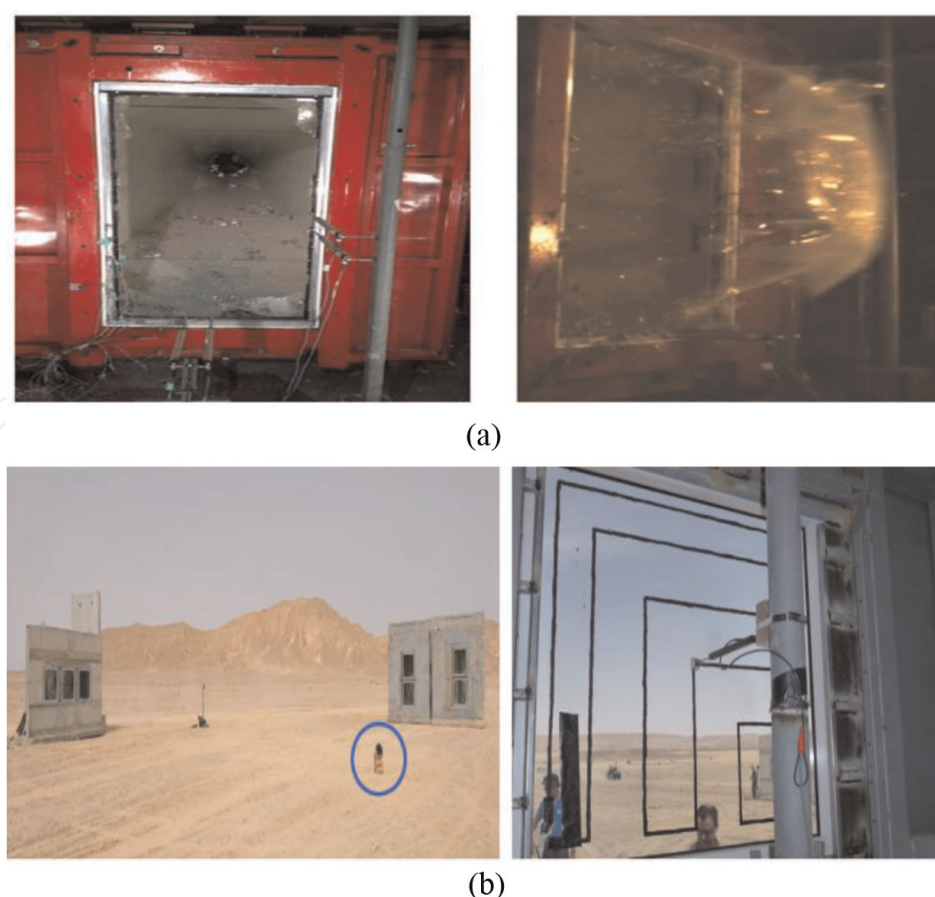

Figure 7. Examples of testing full glass windows under blast loading; a) shock tube blast testing [53] and b) arena testing [54].

4.3.2 Impact load

Impact loads represent a prevalent form of dynamic forces that can inflict significant damage on brittle materials in a short duration of time. Present regulations do not have enough guidance to accurately assess the resistance of glass elements to various types of impact loading. The classification of impact loading, as outlined in [56], distinguishes between hard body and soft body impact, a division particularly pertinent to glass due to its vulnerability when interacting with harder materials. However, there are only a limited number of regulations such as HR EN 12600 [57], HR EN 356 [58], DIN 18008-4 Annex A document [59] and CWCT TN 76 [60] that detail methods for testing glass resistance to impact. Two commonly used impactors are the spheroconical bag (SB) and the twin tire (TT) which are widely used to assess the performance of glazing under soft body impact. The SB contains glass spheres and weighs 50 kg, while the TT consists of two pneumatic tires inflated to 3.5 bar air pressure, with an additional 50 kg steel mass inside (see **Figure 8**). The International HR EN 12600 standard introduced the TT pendulum protocol to replace the SB impactor. German regulations also permit FE numerical simulations using the TT impact instead of full-scale experiments. Some standards such as CSTB 3228 [62], CWCT TN 76 [60], ACR[M]001 [63] and ANSI Z97.1 [64] still advocate for the SB impactor. These standards evaluate the glass system performance after impact, assessing its ability to withstand breakage, cracks and fragments. The primary regulations influence facade designers and manufacturers to adhere to the original SB approach.

5. Numerical analysis of in-plane seismic load effects

As for many other constructional and structural issues, engineers have consistently turned to numerical methods, encompassing simpler techniques or complicated finite element analysis, to account for intricate nuances in their models. In addition to mitigating the financial burden associated with laboratory testing, these numerical methods facilitate parametric studies involving diverse input variables.

A huge number of research studies can be found in the literature regarding performance evaluation of glass elements and facades under different types of loadings.

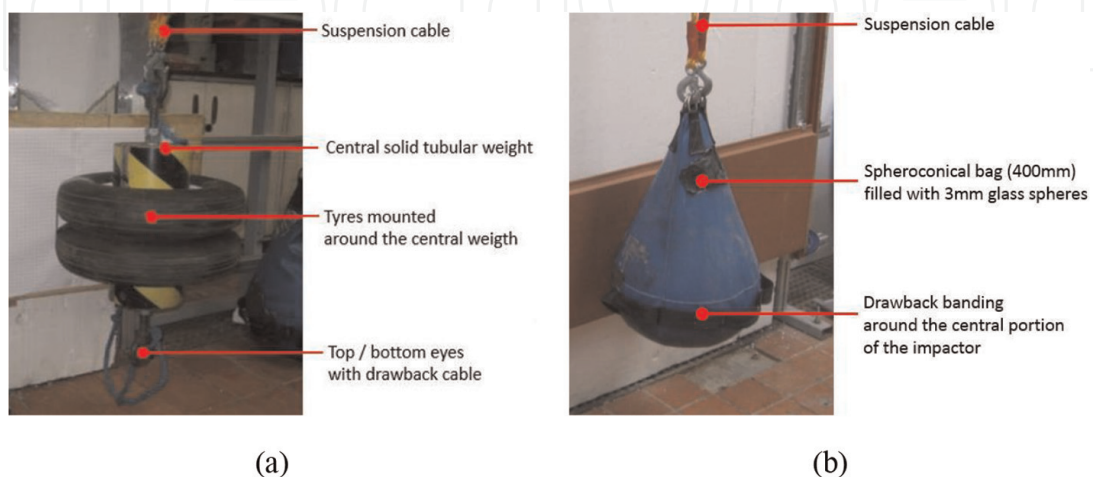

Figure 8. Conventional impactors for glass CWs: (a) twin-Tire and (b) Spheroconical bag (SB, with dimensions in mm) [61].

There are different methods including single degree of freedom (SDOF), multi degree of freedom (MDOF) and finite element (FE) methods that are widely used to find the response of such structures. SDOF methods are always used to find the response of a single member under extreme dynamic loads like blast and impacts [65, 66], while MDOF [67, 68] and FE methods [69–73] not only can be used for single members but also can be utilised for other complicated structures where more details should be taken into consideration. Besides, engineers are always seeking simpler solutions (instead of experimental and numerical analyses) to solve problems that can provide more straightforward analytical approaches for investigating the issue. As a result, analytical methods (which themselves have been validated and calibrated using accurate experimental and numerical results) have also gained importance among researchers, and examples of these can be observed in [16, 74, 75]. Exploring this topic in depth within the confines of this chapter is not feasible; however, more comprehensive explanations can be sought in the technical literature.

In the following, to show the accuracy and applicability of FE models to find the response of a glazing under lateral loading, a numerical model based on Abaqus software is used to evaluate the response of a dry-glazed CW facade under lateral load, based on validation towards literature tests. In this regard, the experimental investigation conducted by Shirazi [76] is taken into account. The schematic of selected experimental test is shown in **Figure 9**. The CW arrangement depicted in **Figure 9**

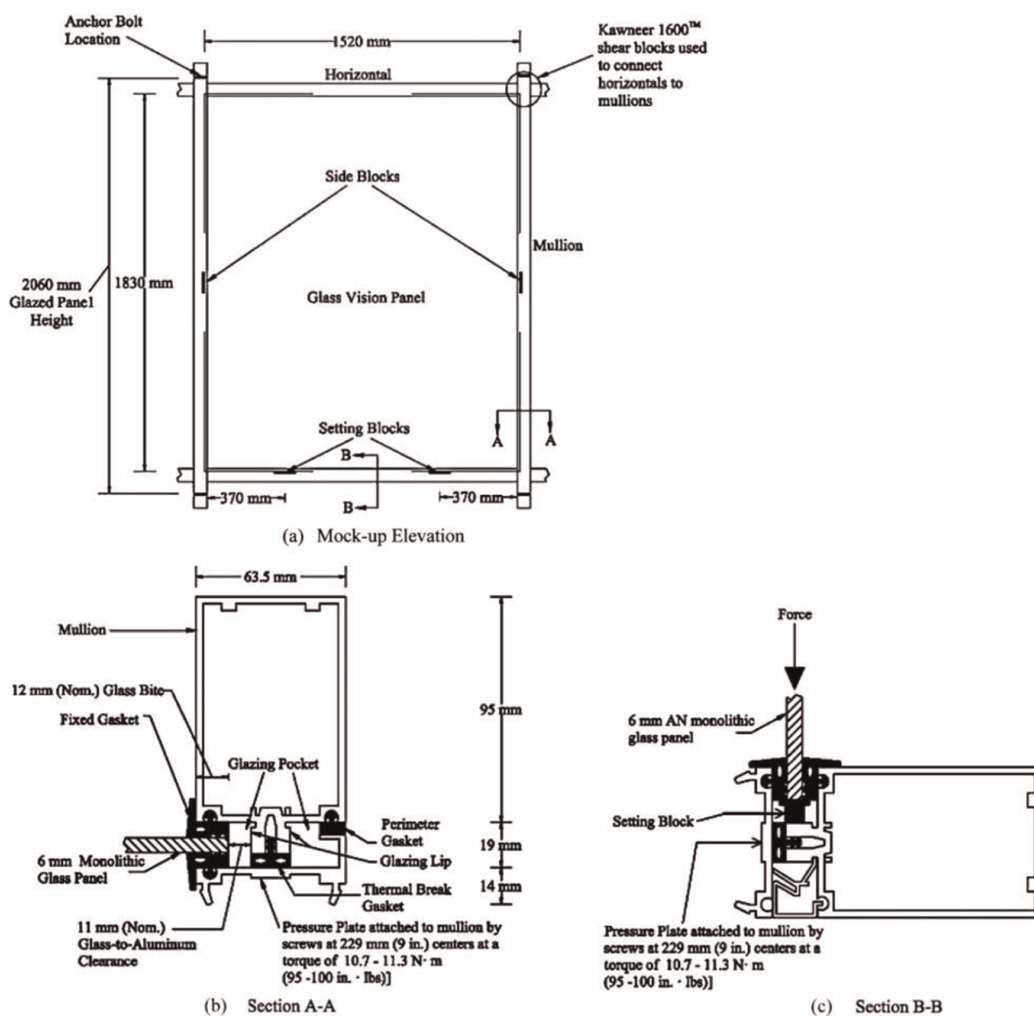

Figure 9. Considered glass CW configuration for mock-up test [71].

features an annealed monolithic glass panel measuring 1829 mm in height, 1524 mm in width, and 6 mm in thickness, which was dry glazed within a Kawneer 1600 aluminium CW frame. It is important to mention that the clearance between the glass and the frame was taken as 11 mm. The pressure plate profiles are affixed to the mullions and transoms using screws spaced at intervals of 9 inches centre-to-centre, and these screws are tightened to a required torque of 10.7–11.3 N-m to secure the glass in position. The CW was subjected to a lateral racking displacement at the top corner of the frame.

To simulate the glass CW, all components (including mullions, transoms, pressure plates, gaskets, perimeter gaskets, thermal gaskets, setting blocks and glass panel), are individually modelled and meshed using C3D8R elements. The particular aspect of the present application – compared to a multitude of literature examples which are based on the use of rough geometrical simplifications – is in fact a full three-dimensional description of CW elements. These parts are then assembled to construct the final configuration. It is important to highlight that the minimum dimension of solid elements is 2 mm, which is primarily applied to gaskets, where higher deflection is anticipated. **Figure 10** shows the CW modelled in Abaqus software.

The FE modelling takes into account various interactions among distinct components, encompassing the interactions between i) glass, transoms and mullions; ii) glass and gaskets; iii) glass and setting blocks; iv) rubber parts (i.e. gaskets, perimeter gaskets, thermal gaskets, setting blocks) and aluminium parts (i.e. mullions, transoms, pressure plates) and v) the semi-rigid connections linking transoms and mullions. In cases (i) and (iii), the normal hard contact and frictionless tangential behaviours are used to define the contact property. In case (ii), the hard contact is used for normal behaviour, while the penalty method with a friction coefficient of 0.65 is used to define the tangential behaviour of contact property. In case (iv), the tie constraint strategy is used, and for case (v), the u-joint connection type is implemented to define

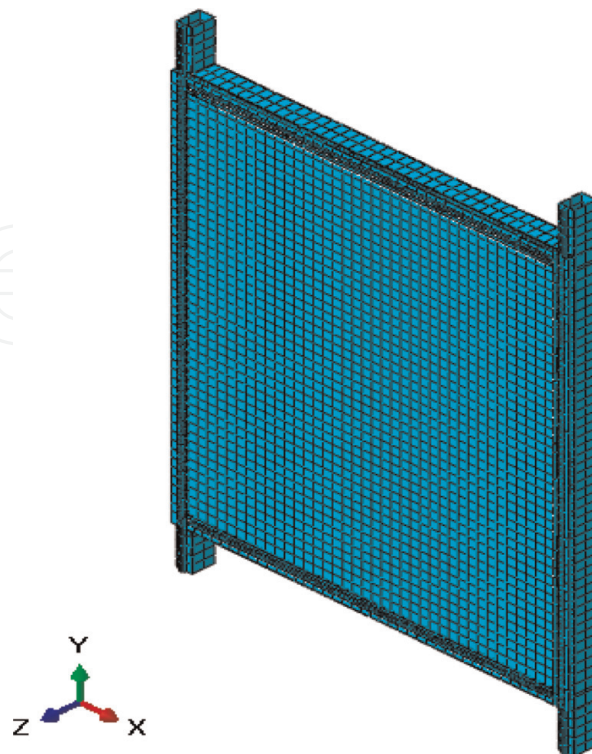

Figure 10.
Glass CW modelled in Abaqus software.

the connector in connecting transom and mullion parts. The U-joint type connector, which is used to connect two reference points at each location (i.e. the connection of the transom to the mullion) by the wire, fixes all translational degrees of freedom and the rotational degree of freedom about the global y-axis.

The glass panel characteristics are defined with a modulus of elasticity of 72 GPa, Poisson ratio of 0.25 and mass density of 2500 kg/m³. For the aluminium parts, values of 69 GPa for the modulus of elasticity, 0.33 for Poisson ratio, and 2700 kg/m³ for mass density are utilised. Regarding the gaskets, the modulus of elasticity is approximated at 4.4 MPa, with Poisson ratio equal to 0.3 and mass density of 1300 kg/m³.

The results of FE analysis are compared with the reference experimental results in terms of load-drift relationship, as demonstrated in **Figure 11**. The figure reveals that there is a rather good agreement between the FE outcomes and the experimental findings. In other words, this signifies that the FE modelling can anticipate the structural responses at particular drift levels during the analysis, in accordance with the experimental findings. These structural behaviours encompass three essential aspects (which are shown in **Figure 11**) including: 1) starting the plastic deformation of the gasket, 2) starting the contact between the glass and the frame and 3) the occurrence of frame and glass failure. Furthermore, the model proficiency in faithfully replicating the glass movement within the glazing pocket enables accurate representation of how the glass comes into contact with the frame, and all these aspects have a key role in structural performance and capacity assessment for similar systems.

Assured that the FE model like in **Figure 10** can be further optimised and simplified to enhance its computational efficiency, it is worth noting that major challenges are related to the accuracy of simplified restraints and boundaries, given that they have a major influence on the stress and strain distribution in glass. Obviously, special modelling assumptions should be taken into account under various loading configurations. However, the goal of ongoing investigations is to capture and define a harmonised modelling strategy for glass facades in general. Also, another important aspect which is presently under investigation is the possible definition of standardised performance indicators that could be used for a given curtain wall exposed to various

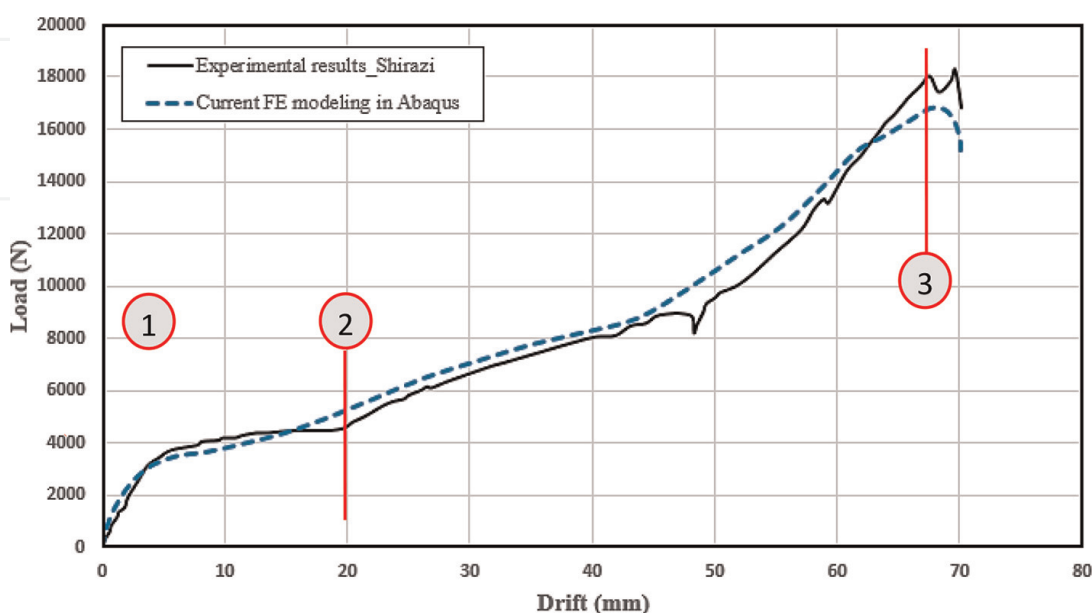

Figure 11. Comparison of load-drift relationship obtained from FE model with experiment.

mechanical loads and for structural health monitoring purposes, diagnostics and life cycle assessment of facades in buildings.

6. Conclusion

A comprehensive exploration of glass curtain wall systems under various dynamic loads, including seismic, wind and impulsive forces like blasts and impacts, is provided by this paper. Regulations, experimental methods and numerical simulations have received special attention, and the essential need for meticulous design, advanced materials and rigorous testing to ensure the structural integrity and safety of these architectural features is emphasised. The array of design standards, regulations and codes available to guide engineers in addressing these dynamic loads is illuminated by the paper. The necessity of a multidisciplinary approach, encompassing elements of structural engineering, material science and architectural design to create glass curtain walls capable of withstanding dynamic loads, is highlighted. Additionally, the role of numerical methods, particularly finite element analysis, in simulating and predicting the behaviour of glass curtain wall systems under dynamic conditions, is underscored by the study. These methods offer cost-effective and efficient means of assessing complex interactions, enabling the evaluation of structural responses and contributing to design optimization. As the boundaries of modern architecture continue to be pushed by architects and engineers, the insights presented here serve as a valuable guidance to ensure the optimal performance of glass curtain wall structures when confronted with dynamic challenges.

IntechOpen

Author details

Mohammad Momeni and Chiara Bedon*

Department of Engineering and Architecture, University of Trieste, Italy

*Address all correspondence to: chiara.bedon@dia.units.it

IntechOpen

© 2023 The Author(s). Licensee IntechOpen. This chapter is distributed under the terms of the Creative Commons Attribution License (<http://creativecommons.org/licenses/by/3.0>), which permits unrestricted use, distribution, and reproduction in any medium, provided the original work is properly cited. 

References

- [1] Ryan P, Otlet M, Ogden R. Steel Supported Glazing Systems. Steel Construction Inst; 1997
- [2] Gil EM. Computational Modeling of Glass Curtain Wall Systems to Support Fragility Curve Development. Virginia Tech; 2019
- [3] Memari AM, Schwartz TA. Glazing and curtain wall systems to resist earthquakes. *Architectural Glass to Resist Seismic and Extreme Climatic Events*. 2009;28-63
- [4] Elkadi H. *Cultures of Glass Architecture*. Routledge; 2016
- [5] Bedon C et al. Performance of structural glass facades under extreme loads—design methods, existing research, current issues and trends. *Construction and Building Materials*. 2018;163:921-937
- [6] Louter C, Bedon C, Kozłowski M, Nussbaumer A. Structural response of fire-exposed laminated glass beams under sustained loads; exploratory experiments and FE-simulations. *Fire Safety Journal*. 2021;123:103353
- [7] ASTM. Standard Specification for Heat-Strengthened and Fully Tempered Flat Glass. ASTM C 1048; 2012
- [8] Haldimann M, Luible A, Overend M. *Structural Use of Glass*. Iabse; 2008
- [9] Zhang X, Hao H. The response of glass window systems to blast loadings: An overview. *International Journal of Protective Structures*. 2016;7(1):123-154
- [10] Zhang X, Zou Y, Hao H, Li X, Ma G, Liu K. Laboratory test on dynamic material properties of annealed float glass. *International Journal of Protective Structures*. 2012;3(4):407-430
- [11] E. Team. Northridge earthquake reconnaissance report. *Earthquake Spectra*. 1996:49-98
- [12] Neyraval P, Egan SM, Basco J, Arques JS. Explosion of 14th January 2020 at IQOXE, Tarragona, Spain. *Chemical Engineering Transactions*. 2022;90:649-654
- [13] Sivaraman S, Varadharajan S. Investigative consequence analysis: A case study research of Beirut explosion accident. *Journal of Loss Prevention in the Process Industries*. 2021;69:104387
- [14] A. Minimum Design Loads for Buildings and Other Structures. American Society of Civil Engineers (ASCE); 2016. pp. 7-16
- [15] Memari AM. *Curtain Wall Systems: A Primer*. American Society of Civil Engineers (ASCE); 2013
- [16] Caterino N. A simplified analytical approach for assessing non-linear in plane seismic response of stick-built glass curtain walls. In: *Structures*. Vol. 49. Elsevier; 2023. pp. 281-294
- [17] UNI EN 1994-1-1:2005 – Eurocode 4 – Design of Composite Steel and Concrete Structures
- [18] Zealand SN. *Structural Design Actions, Part 5: Earthquake Actions*. NZS1170. 5; 2004
- [19] Seminar C. *Nehrp Guidelines for the Seismic Rehabilitation of Buildings (Fema 273)*. Washington, DC, USA: Building Seismic Safety Council; 1997
- [20] A. T. Council and N. E. H. R. Program. *Seismic Performance Assessment of Buildings*. Federal Emergency Management Agency; 2012

- [21] Cremen G, Baker JW. Improving FEMA P-58 non-structural component fragility functions and loss predictions. *Bulletin of Earthquake Engineering*. 2019;**17**:1941-1960
- [22] Del Gobbo GM, Williams MS, Blakeborough A. Seismic performance assessment of Eurocode 8-compliant concentric braced frame buildings using FEMA P-58. *Engineering Structures*. 2018;**155**:192-208
- [23] S. U. Construction and C. Commission. Technical code for building curtain wall. In: DGJ08-56-2012/J12028–2012. Shanghai, China: Shanghai Construction; 2012
- [24] J. 102. Technical Code for Glass Curtain Wall Engineering. China: China Architecture & Building Press Beijing; 2003
- [25] C. S. Association. Guideline for Seismic Risk Reduction of Operational and Functional Components (OFCs) of Buildings. Canadian Standards Association; 2001
- [26] A. JASS14. Japanese architectural standard specification curtain wall. AIOJ (AIJ). 1996
- [27] I. C. Council. Acceptance Criteria for Seismic Qualification by Shake-Table Testing of Nonstructural Components and Systems. Whittier CA: International Code Council AC156; 2007
- [28] A. T. Council, M.-A. E. Center, M. C. f. E. E. Research, P. E. E. R. Center, and N. E. H. R. Program. Interim Testing Protocols for Determining the Seismic Performance Characteristics of Structural and Nonstructural Components. Federal Emergency Management Agency; 2007
- [29] A. A. M. Association. Recommended Static Test Method for Evaluating Curtain Wall and Storefront Systems Subjected to Seismic and Wind Induced Interstory Drifts. Vol. 1. Publication No. AAMA 501.4; 2001
- [30] A. A. M. Association. Recommended Dynamic Test Method for Determining the Seismic Drift Causing Glass Fallout from a Wall System (AAMA 501.6–09). Schaumburg, United States; 2009
- [31] E. 1991-1. Eurocode 1 – Actions on structures. Brussels, Belgium: European Committee for Standardisation (CEN); 2005
- [32] Stathopoulos T, Baniotopoulos CC. Wind Effects on Buildings and Design of Wind-Sensitive Structures. Springer Science & Business Media; 2007
- [33] E. ASTM. 283-rate of air leakage through exterior windows. Curtain Walls and Doors Under Specified Pressure Difference Across the Specimen
- [34] ASTM, editor. Standard Test Method for Structural Performance of Exterior Windows, Doors, Skylights and Curtain Walls by Uniform Static Air Pressure Difference. West Conshohocken, PA: ASTM; 2009
- [35] E. ASTM. 1105–00. Standard Test Method for Field Determination of Water Penetration of Installed Exterior Windows, Skylights, Doors, and Curtain Walls by Uniform or Cyclic Static Air Pressure Difference. West Conshohocken, PA: ASTM International; 2010
- [36] ASTM. Standard test method for field measurement of air leakage through installed exterior windows and doors. 2010

- [37] E. ASTM. Test method for evaluating glass breakage probability under the influence of uniform static loads by proof load testing. 2015
- [38] ASTM E. Specification for performance of exterior windows. Curtain Walls, Doors and Impact Protective Systems Impacted by Windborne Debris in Hurricanes. 1996
- [39] Geurts C, van Bentum C. Wind loading on buildings: Eurocode and experimental approach. In: *Wind Effects on Buildings and Design of Wind-Sensitive Structures*. Springer; 2007. pp. 31-65
- [40] Gholamalipour P, Ge H, Stathopoulos T. Wind-driven rain (WDR) loading on building facades: A state-of-the-art review. *Building and Environment*. 2022;**221**:109314
- [41] Paterson DA, Sankaran R. Hail impact on building envelopes. *Journal of Wind Engineering and Industrial Aerodynamics*. 1994;**53**(1-2):229-246
- [42] Haghightgou N, Daniel S, Badard T. A method for automatic identification of openings in buildings facades based on mobile LiDAR point clouds for assessing impacts of floodings. *International Journal of Applied Earth Observation and Geoinformation*. 2022;**108**:102757
- [43] Kumar A, Saha SK, Matsagar VA. Stochastic response analysis of elastic and inelastic systems with uncertain parameters under random impulse loading. *Journal of Sound and Vibration*. 2019;**461**:114899
- [44] Momeni M, Hadianfard MA, Bedon C, Baghlani A. Damage evaluation of H-section steel columns under impulsive blast loads via gene expression programming. *Engineering Structures*. 2020;**219**:110909
- [45] Momeni M, Bedon C, Hadianfard MA, Baghlani A. An efficient reliability-based approach for evaluating safe scaled distance of steel columns under dynamic blast loads. *Buildings*. 2021;**11**(12):606
- [46] Bedon C. Research developments on glass structures under extreme loads. *Modern Trends in Research on Steel, Aluminium and Composite Structures*. 2021;**1**:3-13
- [47] DoD U. Structures to Resist the Effects of Accidental Explosions. US DoD, Washington, DC, USA. UFC 3-340-022008
- [48] Guide GH. Security Facilities Executive Special Services Group—Explosion Protection. Cabinet Office; 1997
- [49] A. GSA. Standard Test Method for Glazing and Window Systems Subject to Dynamic Overpressure Loadings. Washington, DC: General Service Administration; 2003
- [50] ASTM. Standard test method for glazing and glazing systems subject to airblast loadings. 2012
- [51] ISO. Glass in building—Explosion-resistant security glazing—Test and classification for arena air-blast loading. 2007
- [52] I. 16934. Glass in building—Explosion resistant security glazing—Test and classification by shock tube loading. 2007
- [53] <http://www.ericjacques.com/project/blastresistantanchors/>
- [54] Seica MV, Packer JA, Yankelevsky DZ. Blast and impact loading effects on glass and steel

elements and materials. Thin-Walled Structures. 2019;**134**:384-394

[55] Bedon C et al. A comparison of existing standards for testing blast resistant glazing and windows. European Commission, Joint Research Centre, Institute for the Protection and Security of the Citizen. 2014

[56] Feldmann M, Kasper R, Abeln B, Cruz P, Belis J, Beyer J. Guidance for European structural design of glass components. Publications Office of the European Union. 2014:1-196

[57] Grozdanić G, Galić M, Marović P. Some aspects of the analyses of glass structures exposed to impact load. Coupled Systems Mechanics. 2021;**10**: 475-490

[58] Institution BS. Glass in Building-Security Glazing-Testing and Classification of Resistance against Manual Attack. British Standards Institution; 2000

[59] Siebert G. DIN 18008 Glas im Bauwesen–Bemessungs-und Konstruktionsregeln: Grundlagen und Konzept der Normenreihe. Stahlbau. 2019;**88**(1):32-35

[60] C. T. 76. Technical Note 76: Impact Performance of Building Envelopes: Method for Impact Testing Cladding Panels. Bath, UK: Centre for Window & Cladding Technology (CWCT); 2012

[61] Bez A, Bedon C, Manara G, Amadio C, Lori G. Calibrated numerical approach for the dynamic analysis of glass curtain walls under sphericoconical bag impact. Buildings. 2021;**11**(4):154

[62] C. C. 3228. Resistance Impact on Glass and Glass Roof Infill. Marne-laVallée, France: Centre Scientifique et Technique du Bâtiment (CSTB); 2014

[63] ACR[M]001. Test for Non-Fragility of Profiled Sheeted Roof Assemblies. London, UK: Advisory Committee for Roofwork (ACR); 2014

[64] A. Z97.1. American National Standard for Safety Glazing Materials Used in Buildings—Safety Performance Specifications and Methods of Test. McLean, VA, USA: Accredited Standards Committee (ASC); 2015

[65] Feng R-Q, Ye J-H, Wu Y, Shen S-Z. Nonlinear response spectra of cable net facades. Soil Dynamics and Earthquake Engineering. 2012;**32**(1):71-86

[66] Ding C, Ngo T, Mendis P, Lumantarna R, Zobec M. Dynamic response of double skin façades under blast loads. Engineering Structures. 2016;**123**:155-165

[67] dos Santos FA, Cismasiu C, Bedon C. Smart glazed cable facade subjected to a blast loading. Proceedings of the Institution of Civil Engineers-Structures and Buildings. 2016;**169**(3):223-232

[68] Gupta S, Banfill B, Matsagar V. MDOF Modeling and blast dynamic behavior of Curtain Wall with variable damping approach. Journal of Structural Engineering. 2023;**149**(9):04023122

[69] Bedon C, Amadio C. Numerical assessment of vibration control systems for multi-hazard design and mitigation of glass curtain walls. Journal of Building Engineering. 2018;**15**:1-13

[70] Bedon C, Amadio C. Enhancement of the seismic performance of multi-storey buildings by means of dissipative glazing curtain walls. Engineering Structures. 2017;**152**:320-334

[71] Memari AM, Shirazi A, Kremer PA, Behr RA. Development of finite-element modeling approach for lateral load

analysis of dry-glazed curtain walls.
Journal of Architectural Engineering.
2011;17(1):24-33

[72] Caterino N, Del Zoppo M, Maddaloni G, Bonati A, Cavanna G, Occhiuzzi A. Seismic assessment and finite element modelling of glazed curtain walls. *Structural Engineering and Mechanics*. 2017;61(1):77-90

[73] Aiello C, Caterino N, Maddaloni G, Bonati A, Franco A, Occhiuzzi A. Experimental and numerical investigation of cyclic response of a glass curtain wall for seismic performance assessment. *Construction and Building Materials*. 2018;187:596-609

[74] Bedon C, Amadio C, Sinico A. Numerical and analytical investigation on the dynamic buckling behavior of glass columns under blast. *Engineering Structures*. 2014;79:322-340

[75] Bedon C, Amadio C. Analytical and numerical assessment of the strengthening effect of structural sealant joints for the prediction of the LTB critical moment in laterally restrained glass beams. *Materials and Structures*. 2016;49:2471-2492

[76] Shirazi A. Development of a Seismic Vulnerability Evaluation Procedure for Architectural Glass Curtain Walls. Ph.D. thesis. University Park, PA: Pennsylvania State Univ.; 2005