



Impact of zoning heating and air conditioning control systems in users comfort and energy efficiency in residential buildings

Francisco Fernández Hernández^{a,*}, José Miguel Peña Suárez^b, Juan Antonio Bandera Cantalejo^b, Mari Carmen González Muriano^b

^a Energy Research Group, EII-Universidad de Málaga, C/ Doctor Pedro Ortiz Ramos s/n, 29013 Málaga, Spain

^b Airzone, Corporación Empresarial Altra S.L. C/Marie Curie 21, 29590 Málaga, Spain

ARTICLE INFO

Keywords:

HVAC control system
Energy Efficiency in Buildings
Sustainability Certification methods
Thermal Simulation
Smart System

ABSTRACT

Nowadays, in the residential sector, a widely used Heating, Ventilation and Air Conditioning system is the ducted direct expansion inverter system based on the on/off control of a single zone, which cannot guarantee the thermal comfort in each room of the building. As a solution, the standard EN 15,232 regulates the use of control systems including thermal zoning as a fundamental condition in the energy efficiency in buildings. The zoning system can adapt the equipment working regime to meet the thermal demand in each zone monitoring the air temperature according to users' preferences ensuring the thermal comfort in each zone. Framed in this goal, in contrast to complex and costly control systems, this paper presents a new zoned control system based on thermostats and motorized dampers in each zone, a control board and a communication gateway which allows the communication between the unit and the control board to set operational parameters as the speed of the fan or the supply air set point temperature.

The practical feasibility of this new control system is presented with a thermo-economic comparison analysis with respect the conventional in the context of the Building Research Establishment Environmental Assessment Methodology certification scheme. The model of the zoning system together with implemented control algorithms is developed in TRNSYS17 and the case of study is a residential dwelling in three different Spanish cities. The results show how the thermal zoning control contributes to adapt the thermal energy to each zone in a more efficient way. Moreover, the regulation of the motorized dampers, fan speed and set point temperature of the unit ensures the thermal comfort in all the zones of the building guaranteeing a category B according to the standard regulations. Finally, from the point of view of energy consumption, energy savings from 21 to 42% are obtained, resulting in payback periods of the installation from 3.2 to 4.3 years.

1. Introduction

Nowadays, in the residential sector, a widely used Heating, Ventilation and Air Conditioning (HVAC) system is the ducted direct expansion (DX) inverter system based on the on/off control of a single zone [1]. This system, whose indoor unit has a constant volume fan, can be configured to serve multiple zones based on an on/off control system which turns the HVAC system on and off. However, in many buildings, there is a variety of zones with different users and varying thermal loads. This kind of system ensures the comfort level in the zone where the thermostat is placed but, regarding the rest of the zones, if the load profile is not similar to that of the control zone (use, orientation, thermal loads, etc.), their temperatures can fall outside the comfort range. In the

U.S., 80% of single-family homes, and 60% of multi-family homes utilize this type of system [2], which cannot guarantee thermal comfort in each room of the building.

Recently, the last report of the Intergovernmental Panel on Climate Change (IPCC) [3] ensures that the use of air conditioning systems in buildings will increase with the experienced rise in temperature leading to high energy consumption rates. With this aim, policy packages should combine sufficiency, efficiency, and renewable energy instruments for well-designed and effectively implemented mitigation actions in the buildings sector for achieving the United Nations Sustainable Development Goals (SDG). To satisfy this requirement, it is necessary to ensure the building services, which include shelter, nutrition, sanitation, thermal, visual, and acoustic comfort, entertainment, communications, elevators, and illumination [4]. In that sense, the building management

* Corresponding author.

E-mail address: franciscofh@uma.es (F.F. Hernández).

<https://doi.org/10.1016/j.enconman.2022.115954>

Nomenclature

Variables:

C_d	[-], Degradation coefficient
D_{zi}	[-], Damper position (1 open, 0 close) of the zone i .
FACTOR	[C], Temperature differential factor
NZ	[-], Number of zones in demand.
PLF	[-], Partial Load Factor
PLR	[-], Partial Load Ratio
P_{zi}	[-], Weight of the zone i
$P_{nom,NZon}$	[W], Nominal capacity of the heat pump in a non-zoned system
$P_{nom,Zon}$	[W], Nominal capacity of the heat pump in a zoned system
$P_{occup,zone i}(t)$	[-], Occupational profile value of zone i (1 occupied or 0 not occupied)
Q_{cool}	[kW], Cooling load
$Q_{dem,zone i}(t)$	[W], Thermal load of the zone i in each time step t .
Q_{heat}	[kW], Heating load
$Q_{max,cool,zi}$	[W], Maximum annual cooling load of the zone i
$Q_{max,heat,zi}$	[W], Maximum annual heating load of the zone i
T_{out}	[C], Outside air temperature
$T_{wb,out}$	[C], Wet bulb air temperature
T_{return}	[C], Direct Expansion unit return air temperature
$T_{set,DX}$	[C], Direct Expansion unit set-point temperature
T_{setzi}	[C], Set point temperature of the zone i
T_{zi}	[C], Air temperature of the zone i
$T_{zi}(t-1)$	[C], Air temperature of the zone i at the previous time step
$\Delta T_{max,cool}$	[C], Maximum temperature difference between zone air temperature and set point temperature of zone i in cooling mode.
$\Delta T_{max,heat}$	[C], Maximum temperature difference between zone air temperature and set point temperature of zone i in heating

mode.

$\Delta T_{z,cool}$	[C], Maximum temperature difference between zone air temperature and set point temperature of master zone in cooling mode.
$\Delta T_{z,heat}$	[C], Maximum temperature difference between zone air temperature and set point temperature of master zone in heating mode.
U	[W/m ² K], Overall heat transfer coefficient

Acronyms:

ANN	Artificial Neural Network
BMS	Building Monitoring Systems
BPS	Building Performance simulation tools
BR	Bedroom
BREEAM	Building Research Establishment Environmental Assessment Method
DX	Direct expansion inverter unit
EPDB	Energy Performance of Buildings Directive
GWP	Global Warming Potential
HVAC	Heating, Ventilation and Air Conditioning
IPCC	Intergovernmental Panel on Climate Change
K	Kitchen
LR	Living Room
MPC	Model Predictive Controls
NZon	Non-Zoned control system
OF	Office
PID	Proportional, Integrative and Derivative
PMV	Predicted Mean Vote
PPD	Predicted Percentage of Dissatisfied
SDG	Sustainable Development Goals
Zon	Zoned control system

system is essential to control, monitor and manage the building operations, reducing costs and guaranteeing comfortable indoor conditions. According to this, the Energy Performance of Buildings Directive (EPDB) 2018/844 of the European Parliament [5] promotes the use of HVAC control systems in buildings to optimize energy management and raise end-users' awareness about energy consumption. Classical approaches (typically like PIDs) of HVAC control are the most implemented techniques due to their practical feasibility, but they focus only on indoor environment conditioning rather than efficient control strategies. Consequently, some authors focused their attention on developing HVAC control strategies as the model predictive control (MPC). These approaches rely on building models to accurately predict the indoor temperature and make optimal control decisions. For example, in the domestic sector, Rodrigues et al. [6] presents a MPC for home appliances that require thermal regulation. They studied and compared to the thermostat regulation with the aim of minimizing the cooling energy consumption through the minimization of the energy cost while satisfying the adequate temperature range for the human comfort. Tarragona et al. [7] applied an MPC strategy to a system-based heat pump with photovoltaic panels and thermal energy storage systems compared to an on/off control method and a ruled based control strategy with the purpose of studying the weather effect upon such control technique. In a wider context, Afram et al. [8] suggested a comprehensive review of a type of MPC approach, the artificial neural network (ANN). The authors highlighted different MPC cases of study. For example, Lu et al. [9] modelled an adaptive neuro-fuzzy inference system for duct networks, and Kusiak et al. [10] proposed a data-driven approach adding the uncertainty of the occupation profile. Both methods are applied to obtain an optimal control strategy based on a modified genetic algorithm to minimize the total energy consumption of an HVAC system. From

another point of view, Huang et al. [11] evaluated the performance of a MPC for building energy management. They investigated the combined impacts of selected time intervals for model discretization and control sampling on the performance of the MPC. In general, the analyzed papers estimated the operating cost savings of a residential HVAC system between 6 % and 73 % while maintaining the thermal comfort constraints. In all of these cases analyzed, the MPC strategy is presented as a real and effective alternative to guarantee optimization in the operation of HVAC systems, driving to important monetary and energy savings.

Nevertheless, despite the development of MPC, nowadays it is not generally implemented as the first option in the residential sector. It should be noted that, as the complexity of the system increases (number of sensors, computational costs, etc.), the cost of the installation could become unjustified. In that sense, some authors focused their attention on the following issues. Stopps et al. [12] affirmed that the sensing and actuation infrastructure in North American residential buildings has failed to evolve along with improved building control system methods. Killian et al. [13] also added that the necessary signals for MPC do not exist, so the measurements for MPC are not available, and retrofitting of the whole building would be quite costly. In a broader context, Yao et al. [14] described the practical difficulties of the MPC as real-time application of complex optimization techniques may result in longer computation time, problems with the stability of the controller, rejection capability of disturbances factors, setting time of MPC controller, lack of skilled and efficient experts and cost of retrofitting. For all this, cycling on/off control strategies are the most prevalent [15], and as it was described before, it could not be adequate if only a single zone is controlled.

A robust and simple alternative to the MPC which could be practically feasible is the zoning HVAC control system, available and effective

for retrofitting. In this paper, this concept is applied to a DX ducted unit in a centralized all-air HVAC and is compared to the traditional on/off HVAC control system (called non-zoned system). Thermal zoning is being introduced in the new European directives to ensure comfort in all zones. The EPDB [5] recommends adopting building control and automation systems to control indoor temperature independently if it is economically feasible. In some European countries, the standard EN 15232 [16] regulates the use of HVAC control systems in buildings including thermal zoning as a fundamental condition to ensure energy efficiency and thermal comfort. A zoned system is based on independently controlling the temperature of each of the zones of a building. To do this, a thermostat is installed in each room, allowing the thermal demand in each of the zones to be determined, and the selection of an independent set-point temperature depending on the preferences of the user. When the set-point temperature in a zone is reached, a control signal is sent to the zone's motorized damper which interrupts the air supply to that room. So, in this situation, a zoning HVAC control system provides the ability to control each zone temperature independently, keeping the dampers of the zones which are in demand open, and closing the zones which are not in demand or are not occupied. Therefore, thermal comfort in each zone of the building could be achieved. There are several papers in the literature that relate the advantages of zoned systems. Rodriguez et al [17] proposed a systematically review with the current research on HVAC residential systems based on the description of the zoning methods that support the structural description of the thermal zones of a building, focusing on the design of the HVAC system considering the occupancy patterns and user behavior. From another points of view Shin et al [18] presented a literature review of building thermal zoning for building energy simulation with the aim of analyzing the thermal zoning methods capable of assisting designers with their building energy simulation needs. In that sense, some researchers have applied some of these thermal zoning methods in different case of studies. Lymperopoulos et al. [19] proposed a distributed adaptive control scheme for temperature regulation in multi-zone HVAC systems in the case of study of a school. In a zoned control system, the necessity of the interconnection in real-time of the local controllers of each zone was analyzed to provide a more accurate local zone temperature control. Song et al. [20] evaluated the energy efficiency of end-user groups in multi-zone buildings using energy benchmarking data from seven dormitory buildings in Seoul, Korea. Sookoor et al. [21] presented a control system called room-level zoning, where a network of sensors detects the room state and learns activity patterns that are used to predict occupancy. Thus, conditioning only the rooms with a high probability of occupancy results in energy savings because the load on the HVAC system is decreased. Results show a 20.5% energy savings over the existing single-zoned thermostat during a 20-day evaluation.

Even though a zoned control system can guarantee thermal comfort, from the point of view of the HVAC operation it could be inefficient if it is not complemented with a control system that can act over the performance of the DX unit. For example, when only one or two zones are opened an overpressure in the ductwork can occur if the amount of mass flow rate is not regulated. Accordingly, the novelty of this paper is the presentation of a new zoning HVAC control system, which consists in controlling the temperature of each zone of the building to maintain it within comfort conditions by adapting the thermal power of the equipment to the thermal needs of the zones. It is based on not only the thermostats and the motorized dampers to ensure the thermal zoning but also the use of a control board and a communications gateway, which is a device that enables two-way communications between the control board and the DX unit which allows the control system to read and set some operational parameters of the unit. In this paper, an algorithm is designed to optimize the performance of the system. The control board receives the information of the thermal situation of the zones (air temperatures and set-point temperatures from the thermostats and the position of the motorized dampers) and the algorithm acts setting the operating mode and selecting the adequate fan speed and set-

point temperature of the DX unit, with the aim of ensuring thermal comfort and achieving energy savings.

Compared with the complex MPC strategies analyzed in the literature, a zoned control system can achieve energy savings and thermal comfort results but with the advantages of simplicity, robustness, low initial cost, and ease of use in a retrofitting process. To have a better understanding of the benefits of this control system, the modelling and evaluation of a case of study through a computer-based Building Performance Simulation tool (BPS) is necessary. Within this context, Harish et al. [22] presented a review of a BPS for HVAC control systems. They highlighted that most of the developed models are MPC which still lacks accuracy or which are accurate to a fair degree but a large computer memory and processing or computation time are required. Regarding this problem, it is interesting to have a simplified HVAC control system model that can be incorporated in a BPS and that allows simple interaction with a centralized all-air system in any building. In this sense, the evaluation of the thermal performance of a building in a BPS is one of the requirements of the building certification rating systems, which are known to demonstrate high environmental performance as well as a sustainable and more efficient building [23]. One of the major building sustainability rating systems, widely used in the world, is the Building Research Establishment Environmental Assessment Method (BREEAM). It has been developed in the U.K. since the 1990 s [24] and used as the reference in this study. Some studies highlighted the importance of the BREEAM rating system in the sustainability performance of a building, especially in energy efficiency. Ferreira et al. [25] assess the sustainability level of a Portuguese residential project evaluating how their weighting and criteria approaches can efficiently contribute to reducing buildings' energy consumption. However, in order to assess the credits awarded in energy-related categories, which have the most significant impact on the overall rating, it is necessary to use a computer-based BPS [26]. The zoned control systems can be found as a singular solution, and the simulation libraries included in the conventional software do not provide for the division into zones and the specific zoned control solutions. Therefore, it becomes essential to provide a mathematical model of this zoned control system that could be included in the BPS tools so that engineers or architects can use and evaluate its behavior and quantify its potential impact in the building through the BREEAM methodology.

Therefore, the aim of the authors in the present paper is to demonstrate the performance of the zoned control system, including the control algorithm, compared with respect to the common non-zoned on/off control system. Both control modes are programmed and simulated in TRNSYS17 [27]. The case of study is a residential dwelling in different Spanish cities. A thermo-economic analysis is performed. Firstly, the description and modelling of the control systems are described in detail. Secondly, the simulation results are shown and discussed in the BREEAM certification scheme context. The influence of the thermal zoning in the sizing of the DX unit is evaluated because in some situations the capacity of the needed DX unit could be lower than the one needed with a non-zoned system. The evaluation of the thermal comfort is carried out according to the ISO 7730 standard [28] with the calculation of the Predicted Percentage of Dissatisfied (PPD) and Predicted Mean Vote (PMV) values. Then, the energy consumption of the HVAC system and the energy savings are calculated. Finally, it is easy to make an economic estimation because the adopted zoning control system can be found in the market, so the return of investment period is evaluated.

2. Non-zoned control system

In this section, the description and modelling of the non-zoned and zoned control systems are described.

2.1. Description of the non-zoned control system

The model of a non-zoned system consists of a ducted DX inverter

unit which is configured to serve multiple zones. The system operation is controlled by a thermostat placed in the “master” zone (Fig. 1).

Thus, depending on the relation between the master zone air temperature and the zone set-point, the DX unit control system selects its operating mode, whether the equipment should be on or off, the required fan speed or the appropriate unit set point temperature. As a result, controlled zone temperature is maintained within the comfort range, while other zone temperatures depend on the evolution of its thermal loads. All dampers are always opened and the air is supplied to each room at the temperature required to condition the master zone, usually resulting in overheating or undercooling in the other zones. Therefore, this system is appropriate only for facilities with similar uses and thermal loads profile.

2.2. Modelling the non-zoned control system

As Cetin et al. [1] indicated, most energy modelling software tools do not simulate the on/off nature of this type of HVAC controls and are not typically run in the short timesteps that the operation performance must consider. Energy modelling is usually based on the zone heating and cooling load requirements. In this paper, new models of the DX unit and control systems are created and implemented in TRNSYS, for a better adaptation to the requirements of the simulation conditions. The time step is one minute, the same as that of the operation of the control system.

At zone level, the system has been modelled as an off/on control which is continuously turning on and off the DX unit depending on whether the temperature of the zone is inside or outside the comfort dead-band temperature range (typically 0.5 °C) with respect to the air set-point temperature (see Fig. 2). The comfort dead-band is established to prevent actuators from being constantly modifying their response to slight variations in temperature. The unit is controlled only by the master zone and, the fan speed and the set-point temperature of the unit are set according to its thermal situation.

For example, in heating mode, the zone is cold, in thermal discomfort, and the unit is activated in order to increase the air temperature until the comfort band. The unit remains on until the temperature reaches the upper limit of the comfort band. At that moment, the equipment is turned off and the temperature, due to inertia, will continue to rise for a short period of time causing overheating and, subsequently, due to the heating demand, it evolves freely and decreases until it reaches the lower limit of the comfort zone again, at which time the system is turned on again. As it can be observed, the behavior of the system in cooling mode is similar to that in heating mode but in reverse mode, turning off the unit when the temperature is lower than the lower limit of the comfort band to avoid undercooling in the zone.

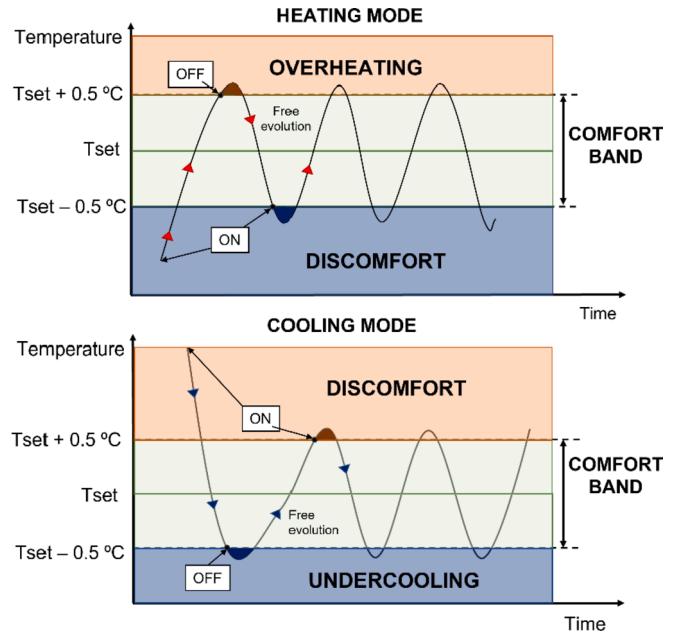

Fig. 2. On/off control in a non-zoned system, in cooling and heating mode.

At system level, the fan speed is selected based on the temperature difference between the zone air temperature and the set-point temperature of the master zone. Fig. 3 represents the change of fan speed in a unit with 3 velocities.

For example, in cooling mode, when the difference is higher than

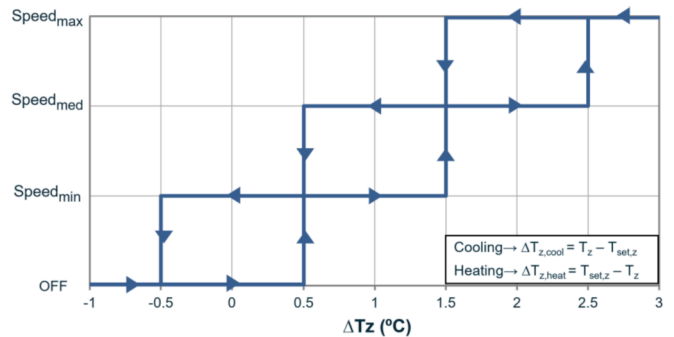

Fig. 3. Selection of the speed of the fan in a non-zoned system.

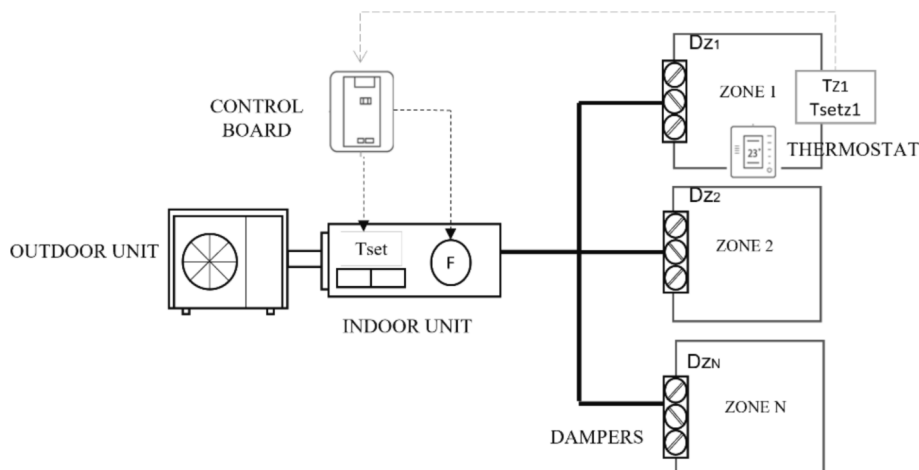

Fig. 1. Non-zoned control system scheme.

2.5 °C, the maximum speed is chosen to decrease the zone air temperature as quickly as possible. Then, the speed of the fan is gradually changed to medium and low speed as the zone air temperature approaches the set-point temperature. When the difference is lower than -0.5 °C the fan is turned off.

3. Zoned control system

In this section, the description and modelling of the non-zoned and zoned control systems are presented.

3.1. Description of the zoned control system

Fig. 4 shows the scheme of the zoned control system. The installation is composed of a ducted DX inverter system, a control board, a communication gateway, motorized dampers, and thermostats.

The control board receives the information from the rooms: the air temperature ($T_{z1}, T_{z2}, \dots, T_{zn}$) and the set-point temperature ($Tset_{z1}, Tset_{z2}, \dots, Tset_{zn}$) imposed by users, from the thermostat placed in each zone (orange dashed lines). With this information, the algorithm imposes, thanks to the communication gateway, the control strategy with the configuration of the next elements (black lines):

- The operation mode according to the user's preferences (stop, ventilation, cooling, or heating).
- The internal unit fan speed (F) is dynamically selected according to the airflow rate demanded by each zone, the number of zones in demand, and the temperature difference between the zone and the air set-point temperature.
- The set-point temperature of the DX unit based on the set-point temperatures in each zone, the air temperature, and the return air temperature to the DX unit, considering the effect of thermal inertia in each zone.
- The position of the dampers (D) of each room which control the amount of air supplied to the zones (Dz_1, Dz_2, \dots, Dz_n). The zones in which there is no occupation, the dampers will be closed.
- The control system can limit the set-point temperature of each room, avoiding too high set-point temperatures in winter or too low in summer.

3.2. Modelling the zoned control system

As described in Fig. 4, the control system acts at two levels: zones and system. Fig. 5 presents the control system model flowchart that resumes the proposed algorithm.

3.2.1. On/off temperature control at zone level

The system has been modelled as described for the non-zoned control system in Fig. 2. Nevertheless, as each zone has its own thermostat and motorized damper, when the zone air temperature is in the comfort dead-band, a control signal is sent to the corresponding zone motorized damper, interrupting the air supplied to the zone. Also, the control system closes the dampers of the zones that are not occupied. Dampers will be opened when the HVAC unit is on and closed when it is off.

3.2.2. Fan speed selection

Concerning the system level, the control algorithm sets the indoor unit fan speed and set-point temperature as a function of the thermal behavior and needs of each zone.

The algorithm selects the indoor unit fan speed according to the thermal demand of each zone with respect to the total number of zones in the building. Each zone has an assigned weight that depends on its thermal behavior. The initial weight of each zone (P_{zi}) is calculated as follows:

$$P_{zi}(\%) = \frac{1}{2} \left(\frac{Q_{max,cool,zi}}{\sum_{i=1}^{nzones} Q_{max,cool,zi}} + \frac{Q_{max,heat,zi}}{\sum_{i=1}^{nzones} Q_{max,heat,zi}} \right) \cdot 100 \quad (1)$$

where $Q_{max,cool,zi}$ and $Q_{max,heat,zi}$ are the maximum annual cooling and heating loads of the zone i . Then, each zone is assigned a weight which corresponds to the thermal needs according to its orientation, internal gains, etc. The thermal loads are previously calculated, and the control system is initially preconfigured with the calculated weight of the zones. In addition, the algorithm calculates the total weight of zones in thermal demand as the ratio between the sum of the weights of the zones which are in demand with respect to the total sum of the weights of the zones. From this value, the speed of the fan is selected in relation to the number of speeds of the fan, as shown in Table 1.

If the case is, for example, a 3-speed equipment (V3) and a 5-zone installation, the algorithm will act as follows. If in the beginning, all zones are in thermal demand, the weight is 100% and the system selects the high speed of the equipment. If the user turns off a zone with a

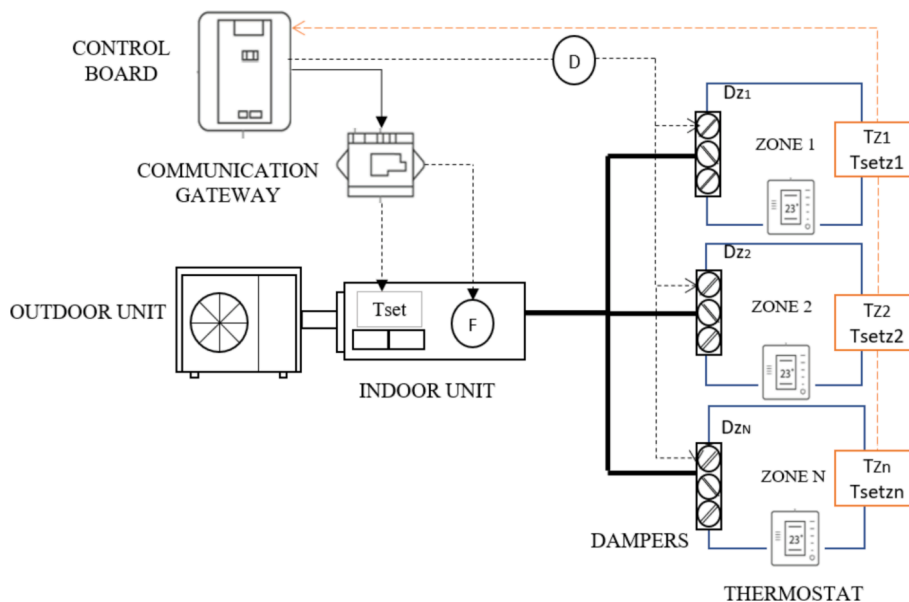

Fig. 4. Zoned control system scheme.

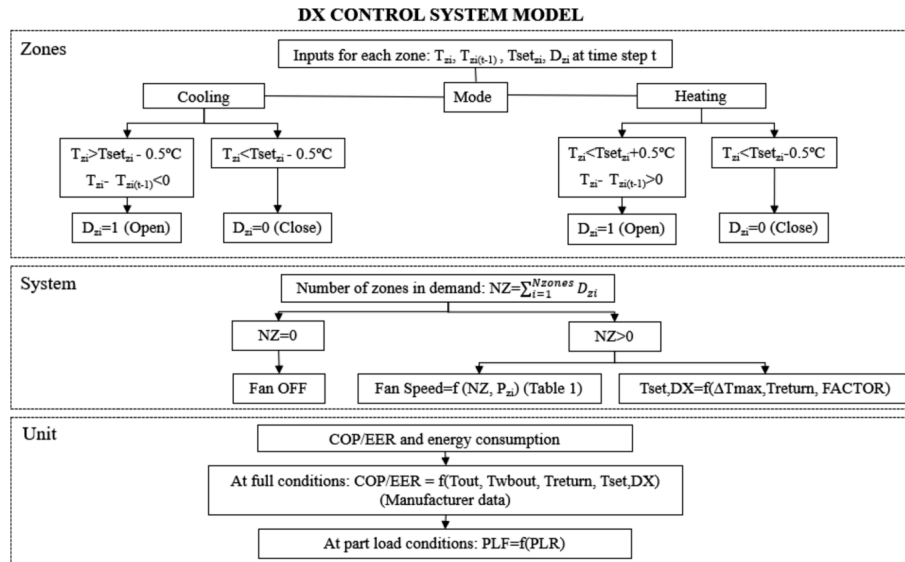

Fig. 5. Flowchart of the DX control system model.

Table 1
Selection of the fan unit's speed.

Selected fan speed	Available speed stages			
	V2	V3	V4	V5
1	[1–50]	[1–34]	[1–25]	[1–20]
2	[51–100]	[35–67]	[26–50]	[21–40]
3	–	[68–100]	[51–75]	[41–60]
4	–	–	[76–100]	[61–80]
5	–	–	–	[81–100]

weight of 30%, the total weight on demand is 70% and, according to Table 1, speed 3 is maintained. When a zone (with a weight of 20%) reaches thermal comfort, the total weight on demand is 50% and the speed of the fan is automatically changed to the second. When another zone reaches comfort and the total weight on demand is 20%, the low speed is selected to adapt the installation to this situation. If there are no zones in thermal demand, the total weight in demand is 0% and the fan is turned off. In this way, the algorithm allows identifying the zones which have a higher thermal load than others and acts accordingly. Another advantage of changing the fan speed and then, adjusting the air mass flow rate to the zones as dampers are being sequentially closed, is avoiding an overpressure in the ductwork when only one or two zones are opened. In the case of a zoned control system but without the work of the communication gateway, which allows changing the speed of the fan, a by-pass should be needed. For that reason, in this study, the air distribution ductwork is not modelled.

3.2.3. Set-point temperature selection

The algorithm controls the DX unit set-point temperature and, also, allows to attenuate the effects of air temperature stratification. The system checks the difference between the zone temperature (T_{zi}) and the established set-points in each zone ($T_{set,zi}$) and takes the maximum of these values, which is calculated for heating ($\Delta T_{max,heat}$) and cooling ($\Delta T_{max,cool}$) mode as follows:

$$\Delta T_{max,heat} = \max(T_{set,zi} - T_{zi}) \quad (2)$$

$$\Delta T_{max,cool} = \max(T_{zi} - T_{set,zi}) \quad (3)$$

The DX unit set-point temperature is calculated considering the ΔT_{max} value, the return air temperature measured by the indoor unit (T_{return}) and the thermal inertia of each zone through a variable called

FACTOR, as follows:

$$T_{set,DX} = T_{return} \pm FACTOR \quad (4)$$

where the *FACTOR* is a function that depends on:

$$FACTOR = f(\text{Number of zones in demand}, T_{set,zi}, T_{zone,i}, \text{Thermal inertia zone } i) \quad (5)$$

The meaning of the *FACTOR* is described in the next example. A building with, for example, 5 zones and operation mode set to heating mode is considered. The $\Delta T_{max,heat}$ corresponds to Zone 1, where the user has set a set-point of 21 °C and the ambient temperature is 17 °C. The return air temperature at the indoor unit is 18 °C. As the ΔT_{max} is high (4 °C), the system establishes that the $T_{set,DX}$ would be 21 °C, 3 °C higher than the return air temperature. As the air temperature of zone 1 increases, so does the return air temperature. In this situation, thermal stratification can occur if air diffusion is not correctly implemented. Therefore, the return air temperature could become higher than the indoor unit set-point temperature and so it would stop heating, but the zone air temperature would not meet the established set-point temperature, causing thermal discomfort for the user. As a solution, the control algorithm establishes a new indoor unit set-point temperature higher than the return air temperature (the sign is positive in equation (4)) to make the HVAC unit work until the set-point temperature is reached in the zone. As the ambient temperature in the zone gets closer to the user set-point, then the *FACTOR* applied over the return air temperature to establish the DX unit set-point temperature is being reduced until the user set-point temperature is reached. Hence, the algorithm is essential to adapt the thermal power of the unit to the thermal requirements of the zones.

3.2.4. Part load ratio performance

The last step is to determine the electrical consumption. Regarding the DX unit, a mathematical model working under different conditions is implemented. In this case, the typical model used in the TRNSYS library has been modified adapting the particularities of the control system. The model uses the information provided by the manufacturers [29] with curves fitted for variation in total and sensible capacity, energy input and part-load ratio to determine the performance and energy consumption of the equipment at full load conditions.

In the actual DX units, with the inverter technology, the rotational speed of the compressor is regulated to adjust the thermal production to the partial load, avoiding degradation by on/off cycles. However, the

mass flow of refrigerant cannot be made arbitrarily small, and there is a minimum speed of the compressor in which the equipment works as an on/off system. According to the partial load factor (*PLR*), which is defined as the relationship between the sensible load demanded and the maximum that the equipment can provide under the same working conditions, the model can simulate these two behaviors. The *PLR* is modified with the Part Load Fraction (*PLF*). The *PLF* refers to the ratio between *COP* under on/off operation and *COP* under full load operation at the same conditions. The correction is important because residential heat pumps predominately operate at part load performance, which depends on numerous factors [30]. A typical part-load performance curve given by the Standard 14,825 [31] is considered. The curve describes the possible trends between the part-load *COP* and the *PLR*, given by the next equation:

$$PLF = 1 - C_d \cdot (1 - PLR) \quad (6)$$

where C_d is a degradation coefficient specified by the manufacturer or a default value of 0.25, recommended by the Standard 14,825 [31]. Recent authors have investigated about the characterization of the efficiency degradation of a DX unit system under part-load operations and criticized this simple approximation. Xu et al. [32] analyzed the mechanism of partial load efficiency degradation of air source heat pumps to obtain the characterization method of *PLF*, and tests to quantify the degradation coefficient were conducted. Dhumane et al. [33] investigated the variation in the cyclic performance of air conditioning systems and concluded that the measured value of C_d from two code testers shows a deviation of about 20%, conforming with the latest rating standards. In both cases, the efficiency losses caused by the on/off cycles with lower *PLR* values are showed.

The influence of the thermal zoning in the *PLR* will affect energy consumption and should be analyzed. The main goal of control algorithms described before is to find the optimum performance point in order to operate with high efficiency, promoting the HVAC operation under favorable partial-load conditions. At very low loads (*PLR* typically lower than 0.2–0.3), the unit works in the on/off performance, and it is not possible to modulate the compressor so the energy efficiency experiences an intense degradation [34]. When the *PLR* values are between 0.3 and 1, the AC unit works at partial load and higher *EER/COP* values are obtained. The energy consumption results should confirm how the thermal zoning affects the partial load operation.

3.2.5. Sizing the unit thermal capacity with a zoned control system

The selection of a DX unit in a building is evaluated to guarantee the possibility of meeting peak loads in all zones. The performance rating of the unit must be greater than the sum of the peak sensible loads of the zones, even if they are not simultaneous. It corresponds to a non-zoned system, the distribution network has no elements that allow the system to deal separately with the needs of each zone. Eq.7 describes the calculation of the nominal capacity of the unit in a non-zoned system ($P_{nom,NoZon}$):

$$P_{nom,NoZon} = \sum_{i=1}^{NZones} \max(Q_{dem,zone i}(t)) \quad (7)$$

where $Q_{dem,zone i}(t)$ is the thermal load of zone *i* in each step of time *t*.

On the other hand, in a zoned system, the distribution network has motorized dampers that allow adjusting the thermal contribution of the system to the demand of each zone separately. This means that the unit is sized by considering the maximum simultaneous sensible load of the zones. For every time step, loads of all zones are added together, and the unit is sized based on the annual maximum for cooling and heating. Eq. (8) shows the calculation of the nominal capacity of the unit in a zoned system ($P_{nom,Zon}$):

$$P_{nom,Zon} = \max \left(\sum_{i=1}^{NZones} Q_{dem,zone i}(t) \cdot P_{ocup,zone i}(t) \right) \quad (8)$$

where $P_{ocup,zone i}(t)$ is the occupational profile value of zone *i* (1 if it is occupied or 0 if it is not occupied).

4. Case of study

After the description of the control system models, the case study is presented in a context of analysis under the premises of one of the most important sustainability rating systems, the BREEAM certification. The building description and the performance evaluation indicators are presented.

4.1. Building description

The dwelling under study (Fig. 6), with a surface area of 121 m², has five heated/cooled zones (living room LR, kitchen K, office OF, children’s bedroom BR1 and parents’ bedroom BR2),

The simulation is carried out in different Spanish cities: Valencia, Madrid, and Barcelona. EnergyPlus weather files are used in the simulation [35]. The enclosures are representative of standard regulation in Spain for every climatic zone. Table 2 shows the values considered for the overall heat transfer coefficient of the different enclosures of the dwelling, according to the standard [36].

A typical occupancy profile in residential buildings is applied to determine the operation of the HVAC system (Fig. 7). The family consists of 4 people with the typical profile of use of a home, with a level of metabolic activity of sitting very light work (120 W) in the living room and office, sitting at rest (100 W) in the bedrooms and standing light work (185 W) in the kitchen [28]. The internal gains corresponding to lighting and equipment are 5 W/m² and 10 W/m², respectively. A rate of 0.6 renewals/hour is set for outdoor ventilation airflow in all rooms except the kitchen, which is set at 2.9 renewals/hour.

4.2. Performance evaluation indicators. Categories of BREEAM certification

The study has the objective of evaluating the ability of the zoned control system to achieve comfort conditions in all spaces optimizing the energy consumption. With this aim, the zoned control system will be analyzed in a building project in the context of the BREEAM certification score, which is influenced in the following categories: Management, Health and Wellbeing, Energy, Pollution, and Innovation [24].

1. In the Management category, the “Sustainable management” requirement offers up to 6 points thanks to the access by cloud and the Building Monitoring Systems (BMS) integration.
2. In the Energy category, the “Reduction of energy use and carbon emissions” requirement offers up to 15 points in recognition of those buildings which are designed to minimize operational energy consumption. Moreover, with the “Energy monitoring” requirement up to 2 points are available.

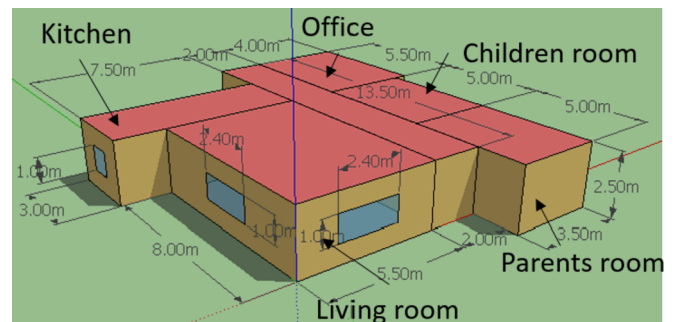

Fig. 6. 3D representation of the home.

Table 2
Threshold U-values (W/m²K).

City	Wall	Ceiling	Floor	Window
Madrid	0.48	0.35	0.65	1.8
Valencia	0.58	0.44	0.75	2.3
Barcelona	0.53	0.40	0.70	2.1

- In the Health and Wellbeing category, up to 3 points are available in the “Thermal zoning” and “Thermal comfort” requirements. This is based on the calculation of the PPD and PMV comfort parameters, and on compliance with category B of comfort, according to the EN ISO 7730 [28].
- In the Pollution category, up to 1 point is available in the “GWP of refrigerants –building installations” requirement.
- In the Innovation category, up to 6 additional points can be obtained for achieving exemplary levels in “Sustainable management” (1) and “Reduction of energy use” (5) requirements.

The monitoring of temperatures in each zone and energy consumption via mobile device by cloud integration ensures the Management category. Also, the new model of the control system allows to perform the simulations, and the results will show how the zoned control system can contribute to the achievement of high scores in the Energy, Health and Wellbeing, Pollution, and Innovation categories. Finally, an economic study is evaluated to assess the economic viability of this control solution.

5. Results and discussion

In the following sections, the performance and the robustness of the zoned control strategy to manage the HVAC system is compared against the behavior of the non-zoned system. The criteria used for the comparison are the electricity consumption and the comfort level. Previously, the influence of the thermal zoning is evaluated in the sizing of the DX unit. Finally, the economic viability is analyzed from the calculation of the payback period.

5.1. Influence of the thermal zoning in the sizing of the unit capacity

The calculation of thermal loads in the house in each city is done with the user comfort range between 22 °C and 24 °C. A good sizing of the unit is crucial to obtain good seasonal performances [37], therefore, it is important to analyze the influence of thermal zoning in the sizing procedure. As described in section 3.2.5., the sizing of the DX unit has been carried out according to the peak loads (non-zoned system) or simultaneous loads (zoned system), as specified by Eqs. (7) and (8).

Table 3 shows the peak (NZon) and simultaneous (Zon) loads for the three cities, the percentage of thermal load reduction in heating (% Heat) and cooling (% Cool), and the abbreviation of the model of the heat pump from a common manufacturer [29].

It should be noted that the sizing of the unit according to the simultaneous loads allows the installation of a heat pump with a lower capacity than the typical peak load sizing procedure in the considered cities. In autumn and spring periods, or in warmer climates, thermal demand is usually small and there is a discrepancy between the thermal load of the building and the capacity of the DX unit. Thermal zoning helps to avoid this problem because the sizing of the unit is adjusted to the thermal demand of each zone. Hence, the reduction of the capacity of the unit allows to decrease the amount of refrigerant in the installation, with the consequence score in the pollution category.

By looking more into detail, as the weather is colder, the influence of thermal zoning in the heating season is lower in this aspect. This is because, when a zone is not in demand or there are no people in it, the load of the zone increases and when it is activated, the unit should meet a higher accumulated load. This effect has more influence in colder climates where the difference between the peak and simultaneous load is not very high.

5.2. Thermal comfort

Firstly, the operation and performance of both control systems for the living room (LR), office (OF), and parents’ room (BR2) is analyzed on a typical summer day, the 30th of July, in Madrid (Fig. 8), the hottest day of the year with a maximum of 36 °C. The simulation time step is one minute, the same as that of the operation of the control system.

Fig. 8 represents the influence of the thermal zoning in the thermal behavior of zones. In a zoned system (upper graph), all the zones are in

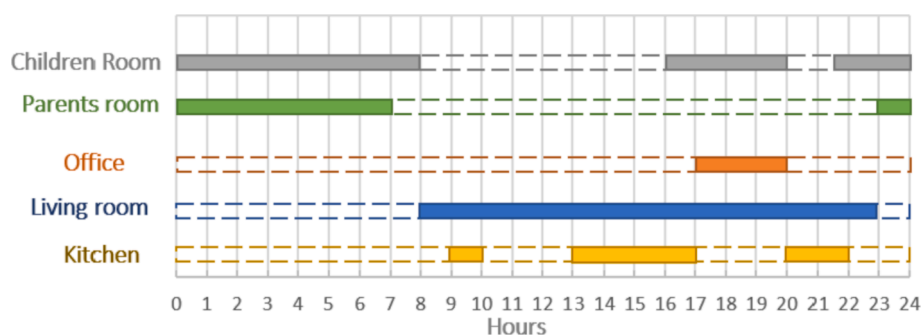

Fig. 7. Occupational profile of the house.

Table 3
Thermal peak loads of each city and heat pump model sized.

City	Madrid		Barcelona		Valencia	
	Zon	NZon	Zon	NZon	Zon	NZon
Qheat (kW)	6.8	7.5	5.5	6.3	4.8	5.7
Qcool(kW)	4.4	5.7	4.5	5.5	4.3	5.5
% Heat	9.3		12.7		15.8	
% Cool	22.8		18.2		21.8	
Heat Pump model	BQSG60D	BQSG71D	BQSG50D	BQSG60D	BQSG50D	BQSG60D

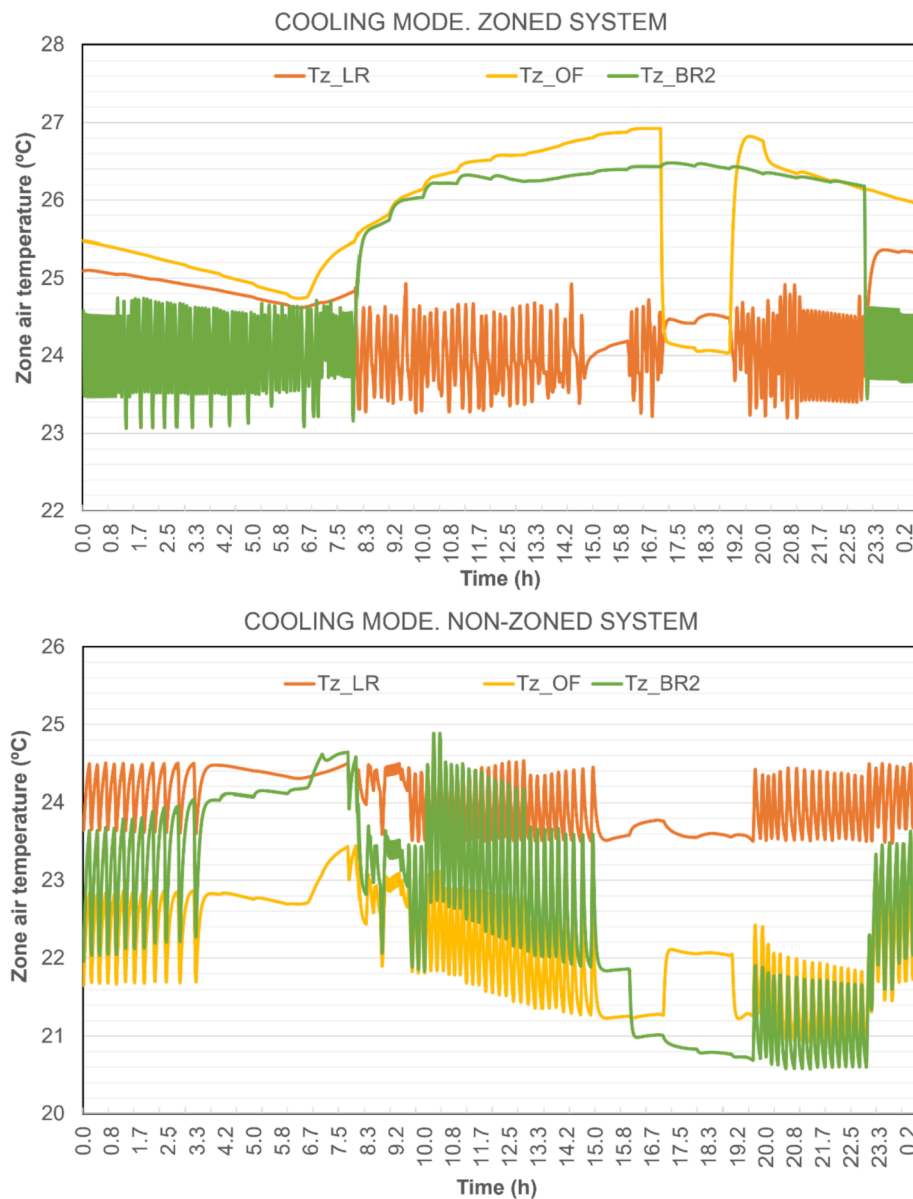

Fig. 8. Temperature evolution in a typical cooling day for zoned and non-zoned systems.

thermal comfort in the time range of the occupational profile, while the rest of the time, the evolution of the temperature is not maintained within the comfort dead-band. For example, the bedroom (green curve) is comfortable from 23:00 to 8:00, but the rest of the day the temperature increases until about 27 °C. The office is only in demand from 17:00 to 20:00, and the living room is occupied during daytime hours, both in thermal comfort within these periods. On the other hand, the comparison with the non-zoned system is very interesting (lower graph). The evolution of the temperature in the living room is very stable, around the set point of 24 °C, but it can be seen how the temperatures of the office and the bedroom are lower, between 21 and 22 °C during all day. Therefore, undercooling occurs in these zones with the consequent thermal discomfort of the users.

From these results, a more detailed comfort analysis is evaluated in each zone according to the ISO 7730 standard [28]. The design criteria for a standing or relaxed person (1 met) wearing typical winter (1 clo) and summer (0.8 clo) indoor clothing are considered with air velocity set to 0.1 m/s. According to this standard, three comfort categories are presented as follows:

- Category A: PPD < 6% and PMV between -0.2 and 0.2.
- Category B: PPD < 10% and PMV between -0.5 and 0.5.
- Category C: PPD < 15% and PMV between -0.7 and 0.7.

Fig. 9 compares mean PPD and PMV values for a zoned and non-zoned system, in each zone of the building and for the cooling (from May to September) and heating (from October to April) seasons.

The BREEAM comfort requirement demands a category B for a high-quality building. Then, in a first general analysis, it should be noted that, in all the situations, the differences between the PPD and PMV values in the living room for a zoned and non-zoned system are not noticeable, so the control system of the non-zoned system guarantees thermal comfort in the master zone. However, it can be seen how PPD and PMV values in the rest of the zones are out of the comfort category in the non-zoned system. Above all, the differences are more significant in both bedrooms, with long periods where PPD values are higher than 15%, and PMV values show slightly cool and slightly warm thermal situations, with average PMV values from -0.8 to 0.9, so occupants are in thermal discomfort. These results corroborate the conclusions obtained in the discussion of Fig. 8, where in the non-zoned system, it was observed that

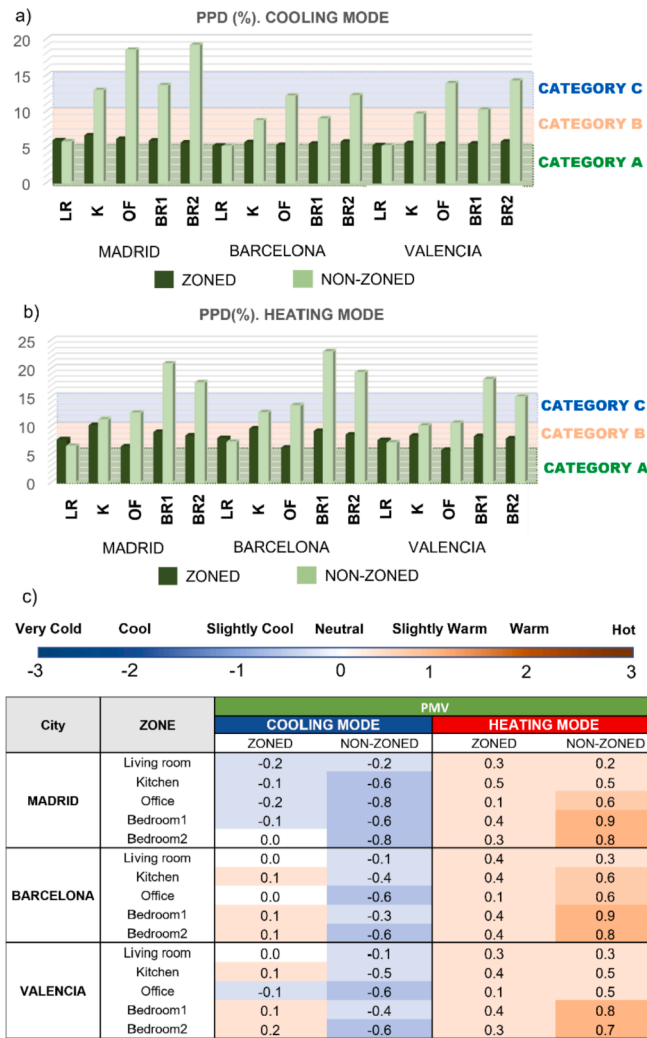

Fig. 9. Comparison of thermal comfort for a zoned and non-zoned system. a) PPD cooling mode, b) PPD heating mode, c) PMV cooling and heating mode.

BR2 and OF zones were undercooled because they were not controlled. Besides, the most important point is that the zoned system guarantees PPD and PMV values corresponding to a minimum of a category B of thermal comfort in all the zones for the 3 cities. On the contrary, a thermal comfort category C is obtained with a non-zoned system, and even thermal discomfort is reached in some cases, as the case of the bedrooms in Barcelona and Madrid, in heating mode, with mean values of PPD higher than 20%. When the analysis is focused on the time evolution of these values, it can be observed that the deviation from the comfort zone occurs in the intermediate months, when the DX unit

operates mainly in part-load performance. This situation confirms the advantages of the sizing procedure with simultaneous loads in the zoned system, which can adapt the power of the unit to the needs of the zones.

5.3. Energy consumption

To complete the evaluation, it is important to compare both control systems by analyzing the energy consumption of the equipment. Fig. 10 presents a comparison in terms of the energy consumption and the energy savings obtained with the zoned system.

In all cases, the energy consumption is reduced when a zoned control system is installed, and energy savings are achieved in the three cities under study. In heating mode, Madrid is the city with the highest energy consumption and the zoned system achieves a 21% of savings, while energy savings are 34 and 42% in Barcelona and Valencia, respectively. Regarding the cooling season, energy savings are also significant, from 21 to 31%. From the point of view of the climate conditions, energy savings are lower in Madrid because it has a colder winter and a hotter summer, so the thermal inertia that the DX unit must overcome in non-occupied zones is higher than in mild climates such as Barcelona and Valencia.

In addition, the influence of thermal zoning, mainly in mild climates, could be analyzed from the point of view of the PLR of the DX unit. Warm winters result in the oversizing of the heating capacity of the DX unit and the number of hours in which the unit works with a low part load ratio (PLR between 0.1 and 0.3) is higher. Consequently, the energy consumption increases caused by a lower COP value at 30–40% lower than the nominal COP of the unit. Thereby, the use of a DX unit with a lower heating capacity avoids oversizing, thus increasing the number of hours with a higher PLR performance.

Finally, according to different regulations which limit the set-point temperature in buildings to reduce energy consumption, it is interesting to take advantage of this control system which has the possibility of adjusting the set-point temperature in each zone. The advantages in energy savings are obvious, as Woo et al. [38] showed in the analysis of diverse thermostat strategies (changes of set-point) in residential buildings in typical USA single-family homes.

So, the algorithm is configured to determine 3 different modes based on how the temperatures in the zones are limited:

- Mode A: Cooling set-point is 24 °C, heating set-point is 22 °C.
- Mode A+: Cooling set-point is 25 °C, heating set-point is 21.5 °C.
- Mode A++: Cooling set-point is 26 °C, heating set-point is 21 °C.

Mode A is the most restrictive and it is the mode considered in this study. Mode A + and A++ have set point temperatures in a range where thermal comfort is reasonably achievable. Fig. 11 shows the energy consumption comparison between the zoned and non-zoned control systems obtained in the simulations of Mode A, A + and A++, for the three cities, in heating and cooling periods, and the percentage of energy consumption difference in each case.

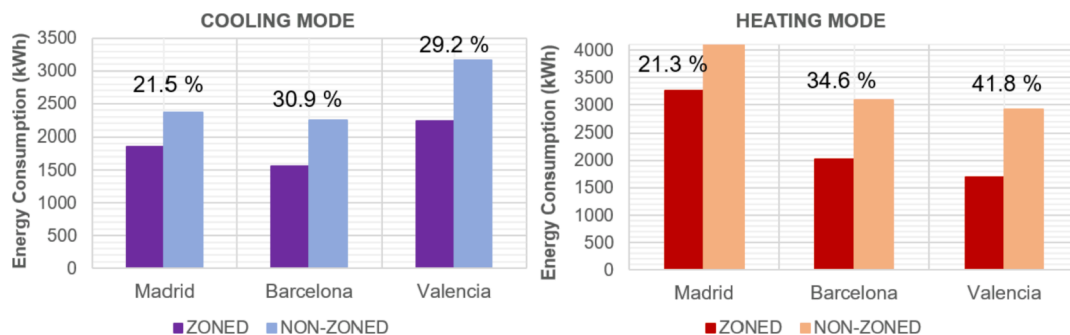

Fig. 10. Comparison of energy consumption in each city for heating and cooling seasons.

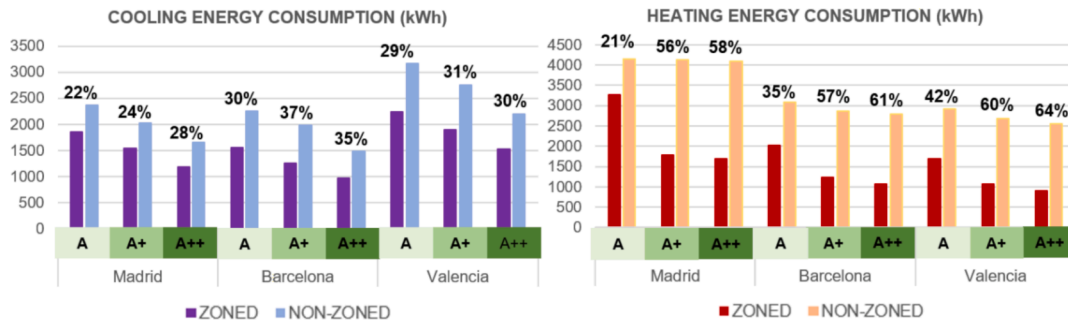

Fig. 11. Comparison of energy consumption with the limitation of the set-point temperature.

As expected, the limitation of the set-point temperature results in lower energy consumption, with savings from 56 to 64% in heating mode, and 24–37% in cooling mode, improving the BREEAM certification score in the Energy category. From the point of view of the climate conditions, it can be seen that the differences are more important for the city of Madrid, with a higher energy consumption in heating mode. The main reason is because the DX unit works with set point temperatures with more favorable which gives rise to better COP values and the influence of the control system in the unit’s energy consumption has a bigger impact. Nevertheless, it should be noted that thermal comfort is very subjective, and users sometimes prefer the manual mode to set their own setpoint temperatures, so the assessment of this analysis should be done in this context. In that sense, Nagele et al [39] affirmed that automated temperature setback variation approaches set in programmable thermostats allow addressing both energy efficiency and thermal comfort. However, in a deeper analysis, Evren et al [40] presented a relation between the thermal comfort and the electric consumption of a hybrid system. They investigated the optimum radiant-convective split based on the analysis of the operative temperature and exergy.

5.4. Economic analysis

The economic analysis is based on the comparison of the investment and the operational cost and thus the payback period of the zoned control system is finally calculated. For this purpose, the considered costs have been consulted from manufacturers’ catalogues and are presented in Table 4. The zoned control system includes the cost of thermostats and motorized dampers for 5 zones, the control board, and the communication gateway.

The investment cost is obtained as the sum of the DX unit plus the zoned control system, considering the DX unit model assigned in each case from Table 3. The operating cost is calculated from the energy consumption results from Fig. 10 and the electricity cost, which is recently updated [42]. Finally, the return of the investment period is calculated from the ratio between the differences between initial costs and operational costs. The economic analysis is presented in Table 5.

The economic analysis shows how the zoned system investment cost, despite the reduction of the thermal capacity of the DX unit, is higher due to the cost of the control system. However, the reduction of the energy consumption results in a lower operating cost and so the payback periods in each city are from 3.2 to 4.3 years. Considering that the lifespan of a DX unit is around 15 years, the payback period obtained is acceptable.

Table 4 Costs.

	DX unit model (€) [29]			Zoned control system (€) [41]	Electricity (€/kWh) [42]
	BQSG50D	BQSG60D	BQSG71D		
Costs	2109	2257	2552	1500	0.20

Table 5 Economic Analysis.

	Initial Investment (€)		Operating cost (€)		Payback Period
	Zon	NZon	Zon	NZon	
Madrid	3757	2552	1024	1303	4.3
Barcelona	3609	2257	714	1067	3.2
Valencia	3609	2257	787	1215	3.8

6. Conclusions

The study presents a zoned control system applied to a ducted DX inverter system as an alternative to the on/off control of a single zone. It is based on the concept of thermal zoning but with the incorporation of a simple algorithm capable of setting the speed of the indoor unit fan and the DX unit set-point temperature, thanks to the communication gateway. A model of the zoned control system is presented as a new type TRNSYS model, although it is available to be introduced in another typical BPS tool, to be used in other energy analysis in buildings, as it is demanded in building’s certification rating systems like BREEAM. In the context of the BREEAM certification, the analysis of the zoned control system is carried out in terms of energy consumption and thermal comfort, in a residential building in comparison to a non-zoned system, and under different climatic conditions. The modelling of the control system allows the evaluation of the possibilities of the control system with the aim of solving the MPC problems mentioned by Stopps [12], Killian [13], or Yao [14] and being a real alternative for air conditioning in the residential sector. The obtained results generally contribute positively to the possibility of getting additional points in the BREEAM qualification of the building, in key areas such as Energy, Health and Wellbeing, and Pollution when compared to a non-zoned system. In addition, the advantages in terms of thermal comfort and energy savings are aligned to the contribution of mitigation policies in the building sector to meeting the SDGs according to the last report of the IPCC [3].

In particular, the most important conclusions are:

The zoned system implies a reduction of the thermal energy, and therefore the possibility of adapting the DX unit capacity more accurately to the thermal demand. For the three cities of study, the zoned control system enables the selection of an HVAC unit model with an immediately lower power than in the case of the non-zoned system. Thus, the initial cost of the HVAC system and the electricity consumption operational cost are reduced.

Zoned system controls each zone temperature independently thanks to thermostats and motorized dampers installed in each room. In contrast, the non-zoned system causes overheating and overcooling in the rooms where there is no thermostat. Consequently, the zoned system guarantees a comfort category of at least level B in each zone and in every city.

The control algorithm of the zoned system regulates the fan speed and air supply set-point temperature adapting the performance of the equipment to the thermal needs of each zone. As a result, the energy

consumption is reduced in all the cases by 21–42% when compared to the non-zoned system. Also, the control system has the possibility to limit the set-point temperature in the zones which implies additional energy savings.

The economic analysis proves the practical feasibility of the zoned control system in new buildings as well as in a retrofitting actuation, by the calculation of interesting payback periods from 3.2 to 4.3 years.

CRedit authorship contribution statement

Francisco Fernández Hernández: Conceptualization, Methodology, Investigation, Software, Writing – original draft, Writing – review & editing. **José Miguel Peña Suárez:** Conceptualization, Methodology, Investigation, Supervision. **Juan Antonio Bandera Cantalejo:** Conceptualization, Methodology, Investigation, Supervision, Writing – review & editing. **Mari Carmen González Muriano:** Conceptualization, Methodology, Investigation, Supervision.

Declaration of Competing Interest

The authors declare that they have no known competing financial interests or personal relationships that could have appeared to influence the work reported in this paper.

Data availability

The data that has been used is confidential.

References

- [1] Cetin KS, Fathollahzadeh MH, Kunwar N, Do H, Tabares-Velasco PC. Development and validation of an HVAC on/off controller in EnergyPlus for energy simulation of residential and small commercial buildings. *Energy Build* 2019;183:467–83.
- [2] United States Energy Information Administration. RECS, Residential Energy Consumption Survey. Washington, DC, USA: U.S. Department of Energy; 2009.
- [3] Bai Quan, Cabeza Luisa F., Bertoldi Paolo, Kihila Jacob, Lucena André, Mata Érika, Mirasgedis Sebastian, Novikova Aleksandra, Saheb Yamina, Keenan Jesse, Serrano Diná Maria Isabel, 2022: Buildings. In: AR6 Climate Change 2022: Mitigation of Climate Change. Available at: https://report.ipcc.ch/ar6wg3/pdf/IPCC_AR6_WGIII_FinalDraft_Chapter09.pdf.
- [4] Vérez D, Cabeza LF. Which Building Services Are Considered to Have Impact on Climate Change? *Energies* 2021;14:3917.
- [5] The European Parliament and The Council of the European Union, Directive (EU) 2018/844 Of the European Parliament and of The Council of 30 May 2018 amending Directive 2010/31/EU on the energy performance of buildings and Directive 2012/27/EU on energy efficiency. Official Journal of the European Union. 2018.
- [6] Rodrigues EMG, Godina R, Poursmaeil E, Ferreira JR, Catalao JPS. Domestic appliances energy optimization with model predictive control. *Energy Convers Manage* 2017;142:402–13.
- [7] Tarragona J, Fernández C, Cabeza LF, de Gracia A. Economic evaluation of a hybrid heating system in different climate zones based on model predictive control. *Energy Convers Manage* 2020;221:113205.
- [8] Afram A, Janabi-Sharifi F, Fung AS, Raahemifar K. Artificial neural network (ANN) based model predictive control (MPC) and optimization of HVAC systems: A state of the art review and case study of a residential HVAC system. *Energy Build* 2017; 141:96–113.
- [9] Lu L, Cai W, Xie L, Li S, Soh YC. HVAC system optimization in building section. *Energy Build* 2005;37:11–22.
- [10] Kusiak A, Xu G, Zhang Z. Minimization of energy consumption in HVAC systems with data-driven models and an interior-point method. *Energy Convers Manage* 2014;85:146–53.
- [11] Huang S, Lin Y, Chinde V, Ma X, Lian J. Simulation-based performance evaluation of model predictive control for building energy systems. *Appl Energy* 2021;281: 116027.
- [12] Stopps H, Huchuk B, Touchie MF, O'Brien W. Is anyone home? A critical review of occupant-centric smart HVAC controls implementations in residential buildings. *Build. Environ.* 2021;187:107369.
- [13] Killian M, Kozek M. Ten questions concerning model predictive control for energy efficient buildings. *Build Environ* 2016;105:403–12.
- [14] Yao Y, Shekhar DK. State of the art review on model predictive control (MPC) in Heating Ventilation and Air-conditioning (HVAC) field. *Build Environ* 2021;200: 107952.
- [15] Wang S, Ma Z. Supervisory and optimal control of building HVAC Systems: a review. *HVAC&R Res* 2008;14(1):3–32.
- [16] UNE-EN 15232:2018. Energy Performance of Buildings - Energy performance of buildings - Part 1: Impact of Building Automation, Controls and Building Management.
- [17] Rodriguez J, Fumo N. Zoned heating, ventilation, and air-conditioning residential systems: A systematic review. *Journal of Building Engineering* 2021;43:102925.
- [18] Shin M, Haberl JS. Thermal zoning for building HVAC design and energy simulation: A literature review. *Energy Build* 2019;203:109429.
- [19] Lymeropoulos G, Ioannou P. Building temperature regulation in a multi-zone HVAC system using distributed adaptive control. *Energy Build* 2020;215:109825.
- [20] Song K, Jang Y, Park M, Lee H, Ahn J. Energy efficiency of end-user groups for personalized HVAC control in multi-zone buildings. *Energy* 2020;206:118116.
- [21] Sookoor T, Holben B, Whitehouse K. Feasibility of retrofitting centralized HVAC systems for room-level zoning. *Sustainable Comput Inf Syst* 2013;3:161–71.
- [22] Harish VSDV, Kumar A. A review on modeling and simulation of building energy systems. *Renew Sustain Energy Rev* 2016;56:1272–92.
- [23] Mansour OE, Radford SK. Rethinking the environmental and experiential categories of sustainable building design: a conjoint analysis. *Build Environ* 2016; 98(Supplement C):47–54.
- [24] BRE, BREEAM offices 2008 assessor manual, BREEAM. Watford: BRE Global Ltd.; 2010.
- [25] Ferreira J, Pinheiro MD, de Brito J. Portuguese sustainable construction assessment tools benchmarked with BREEAM and LEED: An energy analysis. *Energy Build* 2014;69:451–63.
- [26] Schwartz Y, Raslan R. Variations in results of building energy simulation tools, and their impact on BREEAM and LEED ratings. A case of study. *Energy Build* 2013;62: 350–9.
- [27] Thermal Energy System Specialists. TRNSient System Simulation Program (TRNSYS), (<http://sel.me.wisc.edu/trnsys>).
- [28] European standard EN ISO-7730:2005. Ergonomics of the thermal environment – Analytical determination and interpretation of thermal comfort using calculation of the PMV and PPD indices and local thermal comfort criteria.
- [29] Daikin. Technical Specifications. Sky Air Seasonal Classic.
- [30] Safa AA, Fung AS, Kumar R. Performance of two-stage variable capacity air source heat pump: field performance results and TRNSYS simulation. *Energy Build* 2015; 94:80–90.
- [31] Cen. TC113/WG7, prEN 14825, Air conditioners, liquid chilling packages and heat pumps, with electrically driven compressors, for space heating and cooling – Testing and rating at part load conditions. Brussels November 2009.
- [32] Xu Z, Li J. Investigation on the efficiency degradation characterization of low ambient temperature air source heat pump under partial load operation. *Int J Refrig* 2022;133:99–110.
- [33] Dhumane R, Qiu T, Ling J, Aute V, Hwang Y, Radermacher R, et al. Investigation of the variability in the measurement of cyclic degradation coefficient of air conditioning systems. *Int J Refrig* 2021;128:1–11.
- [34] Henderson HI, Parker D, Huang YJ. Improving DOE-2's RESYS routine: user defined functions to provide more accurate part load energy use and humidity predictions. In: 2000 ACEEE Summer Study on Energy efficiency in Buildings Proceedings. Pacific Grove; 2000.
- [35] EnergyPlus (2021) <https://energyplus.net/weather> (Accessed 1.12.21).
- [36] Spanish Building Energy Code. 2019.
- [37] Piechurski K, Szulgowska-Zgrzywa M, Danielewicz J. The impact of the work under partial load on the energy efficiency of an air-to-water heat pump. *EDP Sciences E3S Web of Conferences* 2017;17:0072.
- [38] Moon JW, Han S-H. Thermostat strategies impact on energy consumption in residential buildings. *Energy Build* 2011;43:338–46.
- [39] Nägele F, Kasper T, Girod B. Turning up the heat on obsolete thermostats: A simulation-based comparison of intelligent control approaches for residential heating systems. *Renew Sustain Energy Rev* 2017;75:1254–68.
- [40] Evren MF, Özsunar A, Kilis B. Experimental investigation of energy-optimum radiant-convective heat transfer split for hybrid heating systems. *Energy Build* 2016;127:66–74.
- [41] Airzone. Airzone products Flexa 3. https://myzone.airzone.es/productos/g_ama-actual/flexa-3/.
- [42] Spanish Electric Grid. https://www.esios.ree.es/analisis/1001?compare_indicators=1013,1014,1015&start_date=01-11-2021.