



DISTRIBUTION STATEMENT A:
Approved for Public Release -
Distribution Unlimited

DEPARTMENT OF THE AIR FORCE
AIR UNIVERSITY
AIR FORCE INSTITUTE OF TECHNOLOGY

Wright-Patterson Air Force Base, Ohio

AFIT/GSE/ENY/95D-01

A SYSTEMS ENGINEERING APPROACH TO AIRCRAFT
KINETIC KILL COUNTERMEASURE TECHNOLOGY:
DEVELOPMENT OF AN ACTIVE AIR DEFENSE SYSTEM
FOR THE C/KC-135 AIRCRAFT

THESIS (Vol 2 of 2)

Mark C. Cherry, Captain, USAF
Bruce R. Dewitt, Major, USAF
Christopher G. Dusseault, Captain, USAF
Joel J. Hagan, Captain, USAF
Brian S. Peterson, Captain, USAF

AFIT/GSE/ENY/95D-01

Approved for public release; distribution unlimited

20030401 015

A SYSTEMS ENGINEERING APPROACH TO AIRCRAFT KINETIC KILL
COUNTERMEASURE TECHNOLOGY: DEVELOPMENT OF AN ACTIVE
AIR DEFENSE SYSTEM FOR THE C/KC-135 AIRCRAFT

THESIS
(2 of 2)

Presented to the Faculty of the Graduate School of Engineering
of the Air Force Institute of Technology
Air University
In Partial Fulfillment for the Degree of
Master of Science in Systems Engineering

Mark C. Cherry
Captain, USAF

Bruce R. Dewitt
Major, USAF

Christopher G. Dusseault
Captain, USAF

Joel J. Hagan
Captain, USAF

Brian S. Peterson
Captain, USAF

December 1995

Approved for public release; distribution unlimited

Table of Contents

	Page
Preface.....	v
I. Overview.....	1
II. Simulink description.....	3
III. S.m.....	5
IV. Newmess.m.....	6
V. Single Expendable Launch Simulation -Acmeblck.m.....	8
5.1 A/C.....	8
5.2 Missile_Control.....	9
5.2.1 Misslego.m.....	10
5.2.2 Relanglr.m.....	10
5.2.3 Testnan.m.....	10
5.2.4 Testzero.m.....	10
5.3 Missilexyz.....	10
5.3.1 Divplus.m.....	11
5.4 Missile_Range.....	11
5.5 HitCheck.....	11
5.5.1 Ifend.m.....	12
5.6 MissileVel_Seen_by_A/C.....	12
5.7 Relative_angles_and_range.....	12
5.7.1 Acmanlge.m.....	13
5.8 Quad_data.....	13
5.9 Fire_timing.....	14
5.10 Launch_data.....	15
5.11 Launch.....	16
5.11.1 Lnchtraj.m.....	17
5.12 Go_operational.....	18
5.12.1 Gtoptraj.m.....	18
5.13 Expendable.....	19
5.13.1 Mexphit.m.....	20
5.14 Exppos.m.....	20
VI. Multiple Expendable Launch Simulation - Acmeblcm.....	22
6.1 Launch_multiple.....	22
6.1.1 Lnchtram.m.....	23
6.2 Go_operational_multiple.....	23
6.2.1 Gtoptram.m.....	23

6.3 Exppos1-7.m.....	24
VII. Extras.....	25
7.1 Getit.m.....	25
7.2 Decodefl.m.....	26
III. Simulation Limitations.....	27
8.1 Reduced Probability of Kill Due to Setting Target Elevation Constant.....	27
8.2 Missile Destruction Check Accuracy.....	27
8.3 Reliability of Systems Not Included.....	28
8.4 Discrete Noise.....	28
8.5 Aircraft and Expendable Position Noise.....	28
8.6 Missile Velocity Profile.....	29
Appendix A. Simulink Block Diagrams.....	30
Acmeblk.....	30
A/C.....	31
Missile_Control.....	32
Missilexyz.....	33
Missile_Range.....	34
HitCheck.....	35
MissileVel_Seen_by_A/C.....	36
Relative_angles_and_range.....	37
Quad_data.....	38
Fire_timing.....	39
Launch_data.....	40
Launch.....	41
Go_operational.....	42
Expendable.....	43
Acmeblcm.....	44
Launch_multiple.....	45
Go_operational_multiple.....	46
Appendix B. Simulation MATLAB Code.....	47
S.m.....	47
Newmess.m.....	48
Tracker.m.....	53
Expdata.m.....	55
Expdata1.m.....	73
Records.m.....	75
Plotits.m.....	77
Endgame.m.....	78
Sphere.m.....	79
Recordm.m.....	80

Plotitm.m.....	83
Endgamem.m.....	84
Acmeblck.m.....	85
Acmangle.m.....	135
Division.m.....	136
Divplus.m.....	137
Expos.m.....	139
Lchtraj.m.....	144
Dqxyz.m.....	144
Gtoptraj.m.....	146
Dqxyzopr.m.....	149
Mexphit.m.....	151
Missilego.m.....	154
Relanglr.m.....	155
Testnan.m.....	156
Testzero.m.....	157
Acmeblcm.....	158
Lchtram.m.....	242
Gtoptram.m.....	248
Expos1.m.....	251
Expos2.m.....	253
Expos3.m.....	255
Expos4.m.....	257
Expos5.m.....	259
Expos6.m.....	261
Expos7.m.....	263
Getit.m.....	265
Decodefl.m.....	273

Preface

This volume contains the code for Air Force Institute of Technology Thesis numbered AFIT/GSE/ENY/95D-1. The code was written in Matlab® version 4.2 and was used with Simulink™ version 1.3c. and run on PCs and a Sun SPARC station 2. The code simulated the launch of a shoulder launched line-of-sight missile at a C/KC-135 aircraft on takeoff which tried to defeat the missile by using a kinetic kill device.

I. Overview

The Aircraft-Missile Engagement (ACME) simulation is a digital simulation written in Simulink version 1.3c for Matlab 4.2. The simulation represents the launch of a C/KC-135 aircraft the launch of shoulder launched missile with line-of-sight guidance, and the attempt to intercept the incoming missile by a kinetic kill projectile launched from the aircraft. The simulation provides engagement information such as proximity of the missile to the aircraft, probability of killing the missile (PK), etc.

The simulation began at rotation of the aircraft on the runway. After a randomly generated amount of waiting time, a missile was launched from a random position relative to the runway. The aircraft then detected the missile at a random time after missile launch specified by random distributions which were dependent on the detector. If the detection system was simply a detector, an expendable was launched to the center of the quadrant in which the missile was detected at a time which an average missile would take to reach the aircraft. Since the detector had no ranging capability, a best guess for impact time was the optimal solution for launch timing. If the system had a tracking system, the system launched an expendable toward the missile at the angle specified by the tracker. The timing for expendable launch was determined by the time the missile was expected to reach the lethal distance plus a safety factor. The accuracy of the launch time depended on the range and velocity accuracy of the tracking system. If multiple expendables were to be launched, the expendables were launched at specified intervals. After a set time, the expendable expanded into their operational mode. If the missile came within the kill radius of the expendable, a probability of kill was determined on how

close the missile came to the center of the expendable. For this simulation, any probability of kill was considered a missile kill. If the missile did not come within the kill radius of the expendable, the simulation continued until the missile hit the aircraft or the 25 second time limit was reached, signifying the missile missed the aircraft.

II. Simulink Description

Simulink is a discrete simulation environment which uses integration methods to approximate system parameters for a system at a specified time interval. There are several integration methods which can be used. ACME uses the linsim (linear simulation) integration method.

Simulink simulations are constructed using graphical blocks which are drawn from a standard Simulink library. The simulation has many defined function blocks as well as a 'Matlab Function' block so custom Matlab functions can be used. Variables can enter the simulation workspace from the Matlab environment at the beginning of the simulation by using an input block. These input variables cannot be changed throughout the simulation and only the value when the simulation is begun will be used. Variables can also be sent back to the Matlab workspace by using the appropriate output block. These variables are returned in the form of a vector, with each row representing a simulation time hack. For example, if a simulation runs for ten seconds at one second intervals, an output variable will have eleven rows, with the first row being the initial condition. All variables not already in the Matlab workspace before the simulation is run or sent to the workspace by the appropriate block are considered local to the simulation and are erased when the simulation ends. This included variables which are created in Matlab function blocks within the simulation.

The exception to the above rules are variables which are declared global. These variables can be changed and used from the Matlab workspace within the simulation and

do not gain a new row every time interval. Using global variables should be avoided when possible, however, because such variables require considerable overhead in order to incorporate them into the simulation, increasing run time.

This vague description of Simulink has left out many details and capabilities which will become evident in the discussion of the ACME simulation.

III. S.m

The simulation was initiated from a Matlab m-file, which is a script file of Matlab commands, called *S.m*. This file contained system parameters which were changed often. For example, when a sensitivity analysis was done on the effect of wash noise on PK, the wash noise parameters were put into *S.m* for easy access. This file was run by typing 'S' and pressing return at the Matlab prompt while in the directory of all of the ACME files.

IV. Newmess.m

Newmess.m was then called from *S.m*. *Newmess.m* contained all of the system parameters which were rarely changed. If an analysis were to be done which called for a parameter to be changed often, it would have been moved to *S.m*. Likewise, if a parameter in *S.m* was not going to change often, it was moved back into the appropriate area in *newmess.m* in order to keep *S.m* simple.

The parameters in *newmess.m* were organized by system or function. The global variables were declared first. Global variables were used for three processes: expendable trajectory look-up table calculation, prevention of redundant trajectory calculation, and recording the expendable launch time. These variables will be discussed further in the *lnchtraj.m* discussion.

The Scenario, Missile, and A/C parameters were next, followed by the tracker information. The tracker parameters which changed according to the tracker used were put into *tracker.m* due to the larger number of trackers which were used in the different stages of the Systems Engineering process. The expendable launch and launch timing were then followed by the expendable parameters. The look-up tables for the launch angles and timing were put into *expdata.m* due to their large size. Other expendable characteristics were put into *expdata1.m* due to the large number of expendables which were eventually developed. The rest of *newmess.m* was put into a loop to allow for Monte Carlo simulation runs. The parameters generated within the loop were generated randomly for each simulation run. The actual scenario parameters and detection timing

were random processes, as were the noise which was put into the different system functions.

Once all of the parameters were initialized, the simulation was run for a maximum of 25 seconds with a time interval of 0.001 seconds. The simulation was designed to end when the expendable hit the missile or the missile was within the lethal distance. If the simulation ran the full 25 second, the missile missed the aircraft.

After the simulation was complete, the appropriate data was recorded by running *records.m* or *recordm.m*, depending on whether single or multiple expendable were launched. Likewise, the scenario was graphed by *plotits.m* or *plotitm.m*.

V. Single Expendable Launch Simulation - Acmeblk.m

The Simulink block diagram for the ACME simulation, single expendable launch, was acmeblk.m. The block diagram for a multiple expendable launch was acmeblcm.m. These were viewed and edited by running Simulink (typing 'simulink' and pressing enter at the Matlab prompt) and then loading the appropriate file.

ACME was broken into modularized blocks. Each block is described below.

5.1 A/C

Inputs:

Time

Outputs:

Aircraft velocity

Aircraft position

This block simulated the movement of the aircraft. The climb angle was specified as being constant, but had Gaussian noise added to it with a specified standard deviation. This noise was filtered to give a smooth appearance and the noise value changed every .25 seconds. The velocity was also specified as being constant and had Gaussian noise, but the noise value only changed every second.

The aircraft ideally had no lateral (y-axis) movement, but it was added as Gaussian noise which was updated every second in addition to a constant cross-wind. This movement was simply in position and the lateral velocity was assumed to be zero.

The velocity was simply the integral of the x and z positions over time.

5.2 Missile_Control

Inputs:

A/C position (x,y,z)

Missile position (x,y,z)

Missile Range from launch point

Time

Outputs:

sin component of missile position

cos component of missile position

This block controlled the line of sight logic for controlling the missile. The aircraft was seen as a point mass and the missile targeted that point. The angle between the aircraft and the missile was calculated and entered in to the control loop. Angular Gaussian noise was also added since the missile does not know exactly where the aircraft was located. This noise was filtered and changed every 0.1 seconds. The control loop then generated the thrust angle needed to minimize the angle between the missile and the aircraft in the plane formed from a line from the launch point to the missile and a line from the launch point to the aircraft. Gaussian noise was added to this thrust angle to simulate imperfections in the control surfaces and command signals of the missile. The velocity profile for the missile was derived from a standard thrust profile for a shoulder launched missile: rise to 3600N in the first .6 seconds, maintain thrust until 2 seconds

after launch, and fall to thrust needed to maintain constant velocity (1000N) until 8 seconds after launch. The m-files which were used are *misslego.m*, *relanglr.m*, *testnan.m*, and *testzero.m*.

5.2.1 *Misslego.m* This function provided the velocity profile for the missile. The velocity was a function of the time since missile launch.

5.2.2 *Relanglr.m* This function computed the relative angle between the line-of-sight and the bearing to the aircraft..

5.2.3 *Testnan.m* This function checked to see if the input was zero, infinity, or not a number (NaN). If so, it returned a zero. Otherwise it returned the input value.

5.2.4 *Testzero.m* This function checked to see if a number was zero. If so, it raised it above zero. Otherwise, it returned the input value. This prevented dividing by zero.

5.3 *Missilexyz*

Inputs:

A/C position (x,y,z)

sin component of missile position

cos component of missile position

Outputs:

Missile position (x,y,z)

This block took the output from the control loop and calculated the new missile location coordinates relative to the launch point. It used the m-file *divplus.m*.

5.3.1 Divplus.m This function simply divided two numbers. If the result was not a number (NaN) or infinity, a zero was returned.

5.4 Missile_Range

Inputs:

Missile position (x,y,z)

Outputs:

Missile range from launch point

This block calculated the missile range from launch point for input into the control loop.

5.5 HitCheck

Inputs:

A/C position (x,y,z)

Missile position (x,y,z)

Outputs:

Flag to end simulation

This block calculated the distance between the missile and distinct parts of the aircraft. It could have then ended the simulation if the missile came within a specified distance of any of the areas. If the missile was within the specified distance, a flag telling which area was hit would have been set and the simulation would end.. For this

simulation, only the distance to the center of gravity of the aircraft was measured and could register as a hit.

5.5.1 Ifend.m This function performed all of the functions of the HitCheck block.

5.6 MissileVel_Seen_by_A/C

Inputs:

A/C velocity (z,x)

Missile position (x,y,z)

Outputs:

Relative velocity of missile as seen by the aircraft

This block took the derivative of the missile's position to get a velocity along each axis and subtracted that from the aircraft velocity along each axis. The magnitude was taken to get a true closing velocity of the missile. Gaussian noise was then added to this velocity to simulate the uncertainty the tracking system has in the measurement of the missile velocity. The standard deviation of this noise is a tracking system parameter. The noise was filtered and changed every 0.25 seconds

5.7 Relative_angles_and_range

Inputs:

A/C position (x,y,z)

Missile position (x,y,z)

Outputs:

A/C-missile azimuth

A/C-missile elevation

A/C-missile slant range

This block calculated the relative azimuth and elevation angles from the aircraft to the missile. Zero degrees represents forward and above the aircraft, respectively. The slant range to the missile was also calculated.

5.7.1 Acangle.m This function performed all of the function of the *Relative_angles_and_range* block.

5.8 Quad_data

Inputs:

A/C-missile azimuth

Outputs:

Time for expendable to reach lethal distance from A/C

Launch delay for expendable

This block was used to develop the expendable launch timing for the detector which has virtually no range information on the missile. First, the block determined whether the shot came from the front or rear quadrant. The closing velocity and distance of the missile was then estimated using the probability distributions as to when and from

where the missile would be launched. The launch delay was the estimated distance divided by the estimated velocity. This obviously is very imprecise, but with no range or velocity information of the missile, it is the best that can be done.

5.9 *Fire_timing*

Inputs:

A/C-missile azimuth

A/C-missile slant range

A/C-missile relative velocity as seen by the A/C

Outputs:

Firing Flag

This block determined when to launch the expendable when there was a tracking system on the aircraft. First, Gaussian noise was added to the true slant range of the missile from the aircraft since there is uncertainty in the missile range by the tracking system. The standard deviation of this noise was a tracking system parameter. The noise was filtered and changed every 0.25 seconds. This range estimate was used with the missile closing velocity estimate to calculate an estimated time for the missile to come within the lethal distance. Once this time-to-impact equaled the time needed to get the expendable outside the lethal distance plus a safety factor, a flag was set to launch the expendable.

5.10 *Launch_data*

Inputs:

Missile theta (azimuth)

Missile phi (elevation)

Outputs:

Launch_data information vector

This block created a vector of information needed in the *Launch* block. The vector included the missile elevation relative to the aircraft, the true missile azimuth relative to the aircraft, the time needed for the expendable to reach the missile's lethal distance from the aircraft, the launch elevation and the launch azimuth. The time needed for the expendable to reach the lethal distance, as well as the launch azimuth and elevation were found from a look-up table which was created before the simulation was run. This was done because, even with the assumption of a constant target elevation of 93.12 degrees (see Vol. 1 Appendix E), the calculations needed to calculate the time to target and the needed launch azimuth and elevation were very time consuming. By calculating them before simulation run time, the time needed to run the simulation was reduced dramatically. The target azimuth, which ideally would be the azimuth at which the missile reaches the lethal distance, had a Gaussian noise factor added to simulate the tracking error. The standard deviation of this noise was a system parameter for the tracking system. This noise factor was filtered and changed every 0.25 seconds.

5.11 Launch

Inputs:

Quadrant Launch time-to-target (detector only)

Quadrant Launch delay

Time

Fire Flag

A/C position (x,y,z)

A/C velocity (z,x)

Launch_Data

Outputs:

Operational Time

Launch Flag

This block generated the expendable trajectory for the time between launch and when the expendable became operational (was expelled from launch casing and expanded). Due to the dynamics of the expendable, there was no easy way to generate the trajectory real-time. As a result, the aircraft position and velocity were fed in as initial conditions to the launch of the expendable. A differential equation solver (ODE23) was then used to generate the coordinates of the expendable throughout its launch trajectory.

When the launch trajectory was calculated, a flag was set to tell the simulation that the expendable had been launched. Also, the time at which the expendable was to

become operational was determined. The majority of the calculations were done in *lnchtraj.m*.

5.11.1 Lnchtraj.m This function calculated the trajectory and velocity of the expendable when it was launched and was still in the launch canister. Once the global time reached the launch time, the position and velocity of the aircraft were used to calculate the trajectory for the expendable using the expendable characteristics. The launch time was determined by block *Fire_timing* if a tracker was used or block *Quad_data* if only a detector was used. The trajectory of the expendable was performed using ODE23 which referenced the equations in *dqxyz.m*. A characteristic of the 'linsim' method of simulation in Simulink was that all functions are run twice. This was no problem for the majority of functions, but since the ODE23 equation solve required several minutes for calculation, the simulation time was drastically increased. To prevent this, a global variable (*onceitl*) was used to serve as a flag to tell the function not to re-calculate the trajectory. The results were stored in global variables *exppvx*, *exppvz*, *exppvy*. These variables were matrices with the first row being a time index, the second row a position value, and the third row a velocity value. These matrices were then interpolated by the simulation to find the expendable position. The only way to perform these calculations and be able to use the values later in the simulation was to make the matrices global.

No noise is entered into the expendable trajectory in this function. A flag is set for each expendable from -1 to 1 when the expendable is launched.

5.12 *Go_operational*

Inputs:

Time

Operational Time

Expendable position/velocity

Outputs:

Operational flag

This block similar purpose to that of *Launch*. This block calculated the expendable trajectory after the expendable became operational. Once the time for the expendable to become operational, ODE23 was used to calculate the expendable trajectory for its operational duration given the expendable position and velocity as initial conditions. Again, a variable flag (*onceito*) was used to prevent redundant trajectory calculations. A flag was set to signal the simulation when the expendable became operational and again when it was no longer effective or operational. The majority of the calculations were done in *gtoptraj.m*.

5.12.1 *Gtoptraj.m* This function calculated the trajectory and velocity of the expendable once it was operational. Once the global time reached the operational time, the position and velocity of the expendable were used to calculate the trajectory for the expendable using the new expendable characteristics. This was done using ODE23 (referencing the equations in *dqxyzopr.m*) in the simulation so again, a global variable (*onceito*) was used to prevent the calculation from happening twice. The results were stored in global variables *exppvxopr*, *exppvyopr*, *exppvzopr*.

No noise was entered into the expendable trajectory in this function. A flag was set from -1 to 1 for the expendable when it went operational and from 1 to 100 when it was no longer operational.

5.13 Expendable

Inputs:

Missile position (x,y,z)

Exppos output

Launch Flag

Operational Flag

Time

Expendable Effective Radius

Outputs:

Expendable x,y,z position

Expendable position/velocity (x,vx,y,vy,z,vz,)

PK

Stop Flag

Mexslantrange (slant range between expendable and missile)

Exppos inputs

This block checked to see if the expendable destroyed the missile. Until the expendable was launched, it was assumed to be located at the launch point of the missile. This was done for simplicity since that location is (0,0,0) in the Cartesian coordinates.

Once the expendable became operational, the slant range to the missile was checked to check if the expendable destroyed the missile. This was done in *mexphit.m*.

5.13.1 Mexphit.m This function was used to determine if the missile hit an operational expendable. It used the slant range between the missile and the expendable in comparison with the effective radius of the expendable. If the slant range was less than the radius, it was considered a hit. The resulting PK (probability of Kill) was determined by how close the missile was to the center of the expendable. A PK of .1 indicated the missile hit the outer edge while a PK of 1 indicated the missile hit very close to the center. After the operational duration of the expendable, it could no longer destroy the missile.

The simulation ended if the slant range between the missile and the expendable began to increase (the PK could never have gotten better) or if the expendable exceeded its operational time while the missile was within range (again, the PK could not have gotten any better). This must be kept in mind when analyzing the data for simulations with multiple expendables. The simulation ended when it achieved the highest PK it could have for the first expendable it hit. This gave a deceiving PK since the missile may have hit other expendables and received a better PK had the simulation been allowed to progress.

5.14 Exppos.m

This function returned the position and velocity of the expendable. Until launch, the expendable position was (0,0,0) and the velocity in all directions equal to zero. Once

launched the expendable position was interpolated from the position/velocity matrix formed in *lnchtraj.m* plus a noise position. This noise was used to simulate the virtually unpredictable changes in position due to the wash from the aircraft. A Gaussian noise generator created noise component in all three directions for the first 0.05 seconds after launch. The standard deviation for these noise components could be specified independently. The change in position due to noise was cumulative, i.e. the noise a new noise component was added to the old noise component at each time step. After the 0.05 seconds had elapsed, the noise component remained constant and the calculated trajectory was modified by the constant noise offset until the expendable became operational. This noise offset was then also in the calculations for the expendable once it became operational. Once the expendable became operational, the results from *gtoptraj.m* specified the expendable trajectory until the simulation ended. There were no checks built in to prevent the expendable from going underground since that was irrelevant.

VI. Multiple Expendable Launch Simulation - Acmeblcm

This was the same simulation as *acmeblk.m* except that seven expendable were launched instead of a single one. To allow this, six more Expendable blocks were added, the *Launch* block was changed to *Launch_multiple*, the *Go_operational* block was changed to *Go_operational_multiple*, and Expos1-7 function blocks were added.

6.1 *Launch_multiple*

Inputs:

Quadrant Launch time-to-target (detector only)

Quadrant Launch delay

Time

Fire Flag

A/C position (x,y,z)

A/C velocity (z,x)

Launch_Data

Delay between expendable launches

Outputs:

Operational Time

Launch Flag

This block performed essentially the same function as the *Launch* block except for the fact that trajectories for the seven expendables were calculated at an interval set in *expdata1.m*. Likewise, seven launch flags and operational times were used.

6.1.1 Lchtram.m This function performed all of the functions for the *Launch_multiple* block.

6.2 *Go_operational*

Inputs:

Operational times (1-7)

Time

Expendable positions/velocities (1-7)

Outputs:

Operational flags (1-7)

This block performed essentially the same function as the *Go_operational* block except for the fact that seven operational time were entered, seven expendable initial condition were entered, seven trajectories were calculated, and seven operational flags were set.

6.2.1 Gtoptram.m This function performed all of the functions of the *Go_operational_multiple* block.

6.3 *Exppos1-7.m*

These blocks served the same purpose for the individual expendables as *exppos.m* did for the single expendable. The only difference between them was the names specifying the position/velocity matrices.

VII Extras

7.1 Getit.m

This function was used to calculate the look-up tables for phi launch, theta launch, and time-to-target for the different expendables. Since the equations are so complex, it was impossible to implement them real-time into the simulation. The goal of the simulation was to be able to place the expendable at a certain location on the sphere around the aircraft. This point was referenced using phi and alpha. This was very difficult because the magnitude and duration of the thrust could vary, phi and theta could vary, and so could the time to get it to the point. The result was a very complex dynamic equation. It was determined that since 99% of the missiles entered the sphere within 1.5 degrees of $\phi=93.12$. The target phi was set constant at 93.12. Obviously this is not the ideal situation to maximize the probability of hitting the missile but it was necessary in order to continue with the simulation. With Phi constant, theta and time-to-target were the only true variables and the launch phi, and theta and time-to-target could be calculated using the ODE23 function. Since the climb angle and aircraft velocity were assumed constant, these could be computed prior to simulation and put in a look-up table. This greatly decreased the run-time of the simulation.

The expendable parameters were easily entered into the code and the results were put into a file labeled 'outlaunc.txt'.

7.2 *Decodefl.m*

This m-file allowed the user to easily extract the Probability of Kill from a series of simulation runs. This considered the missile dead if it hit any part of the expendable. The data from the simulation actually gave a range from 0 to 1 for each simulation depending on far from center of the expendable the missile was when it hit (i.e. 0.1 means it hit near the edge & 1 means it hit very close to center). With the multiple shot, the hit check used a radial distance from the center of each expendable so it may have appeared to have hit multiple expendables.

To use this file, the data files were put in the same directory as this file, listed them in the 'infile' variable, and the number of files to be read was specified. All files names in each variable had to be of the same length.

VIII Limitations

8.1 Reduced Probability of Kill Due to Setting Target Elevation as Constant

As mentioned earlier, the target elevation was assumed to be a constant 93.12° (reference Vol. I, Appendix E). Although this elevation was very close to the true elevation of the missile when it reached the lethal distance, the accuracy of the system did not reach its full potential. If a closed form solution of efficient algorithm were discovered which would allow the system to solve for a variable elevation, azimuth, and time-to-target during the simulation, the accuracy, and therefore PK, could be improved.

8.2 Missile Destruction Check Accuracy

Since the 3-dimensional slant range was used, it was theoretically possible for *mexphit.m* to register a hit when the missile would not hit the expendable in the real world. In one time period, the slant range between the missile and the center of the expendable could have been less than the radius of the expendable if the expendable was directly in front of the missile. On the next time step, however, if the expendable was falling fast enough, it could have been out of the path of the missile. For this to have occurred the expendable would have had to fall extremely fast, which was not the case with any of the expendables used in this simulation. Still, this must be kept in mind when developing other expendables.

8.3 Reliability of Systems Not Included

The simulation lacked the realism of having reliability issues affect the outcome of the simulation scenario. In this simulation, the missile was assumed to always function properly and be able to maintain lock. On the other hand, the kinetic kill system was also assumed to function properly. These assumptions were made due to the fact the effects of the reliability issues could be determined outside the simulation using probability and statistical methods..

8.4 Discrete Noise

The noise in this simulation was assumed to be Gaussian, which is not always an accurate assumption. For the scope and purpose of this simulation, i.e. to compare kinetic kill systems, the assumptions were valid. Also true noise is not always discrete or band-limited, as was found in this simulation. This is a limitation of discrete simulation which cannot be avoided.

8.5 Aircraft and Expendable Position Noise

The movement of the aircraft in the y direction and the wash effects on the position of the launched expendable were evident only in position and had no effect on the velocity of the objects. The y axis component of aircraft velocity would have so little effect on the system that it was ignored. The lack of velocity changes of the expendable due to wash effects was a valid concern, but was beyond the capability of the simulation environment to adequately model. An attempt to circumvent this discrepancy was made

by making the noise vector magnitude a random walk rather than noise instantaneously generated . In other words, each new noise vector was added to the previous sum, which amplified the wash effects.

8.6 Missile Velocity Profile

The missile profile used only velocity information from a standard shoulder launch missile rather than the thrust information and missile dynamic characteristics. Although slightly inaccurate, this avoided security classification and simplified the model considerably.

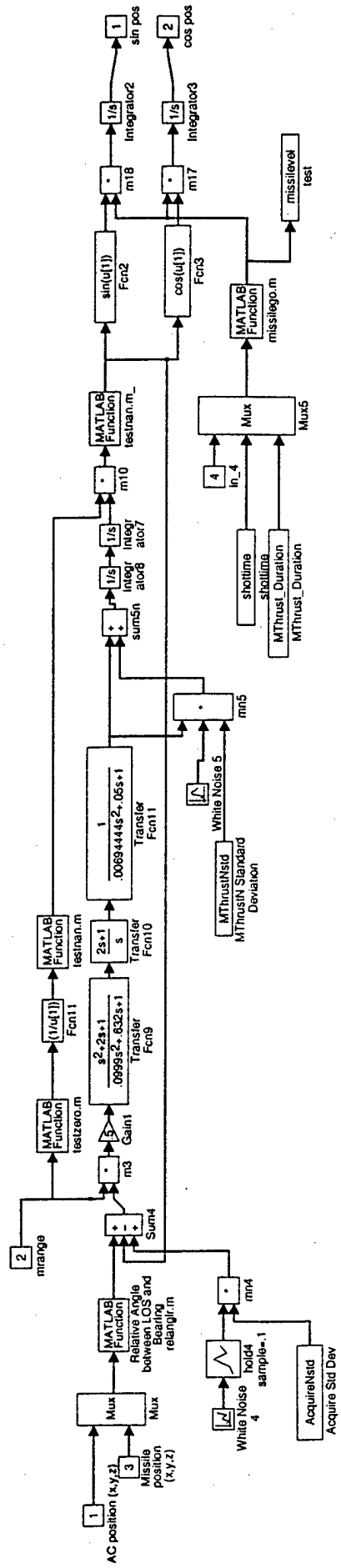

BLOCK: Missile_Control

PAGE 32

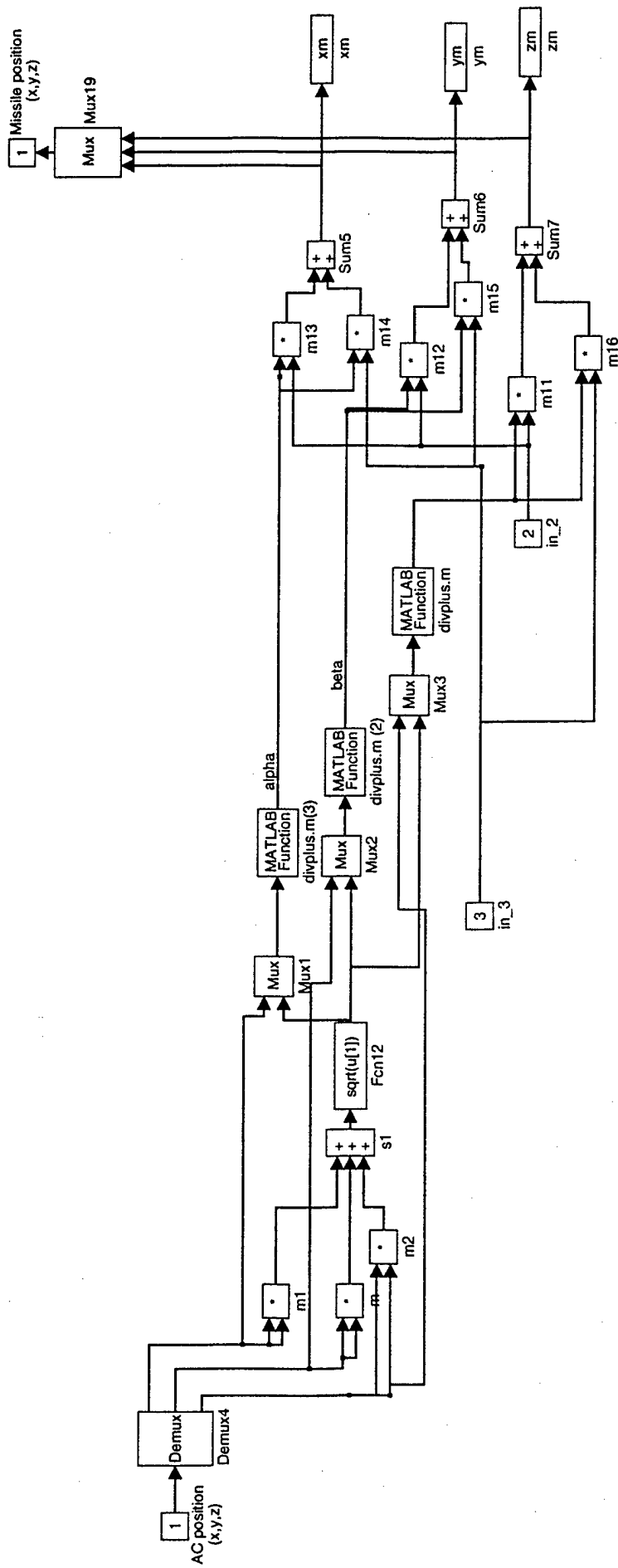

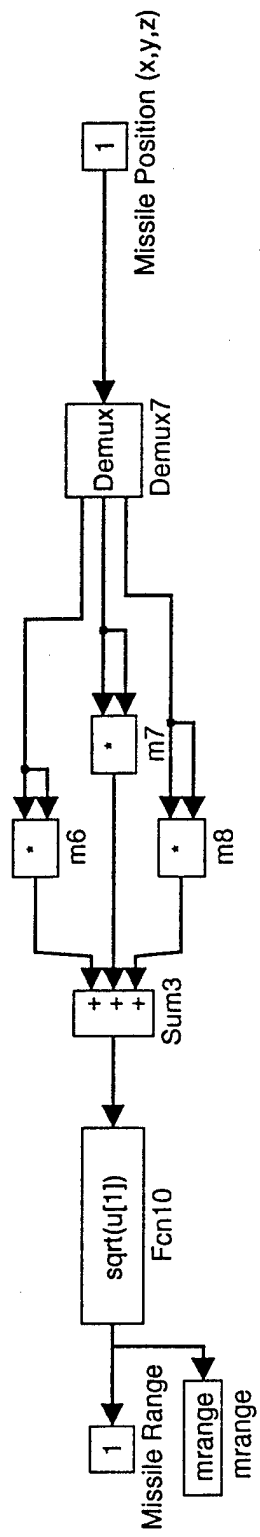

BLOCK: Missile_Range

PAGE 34

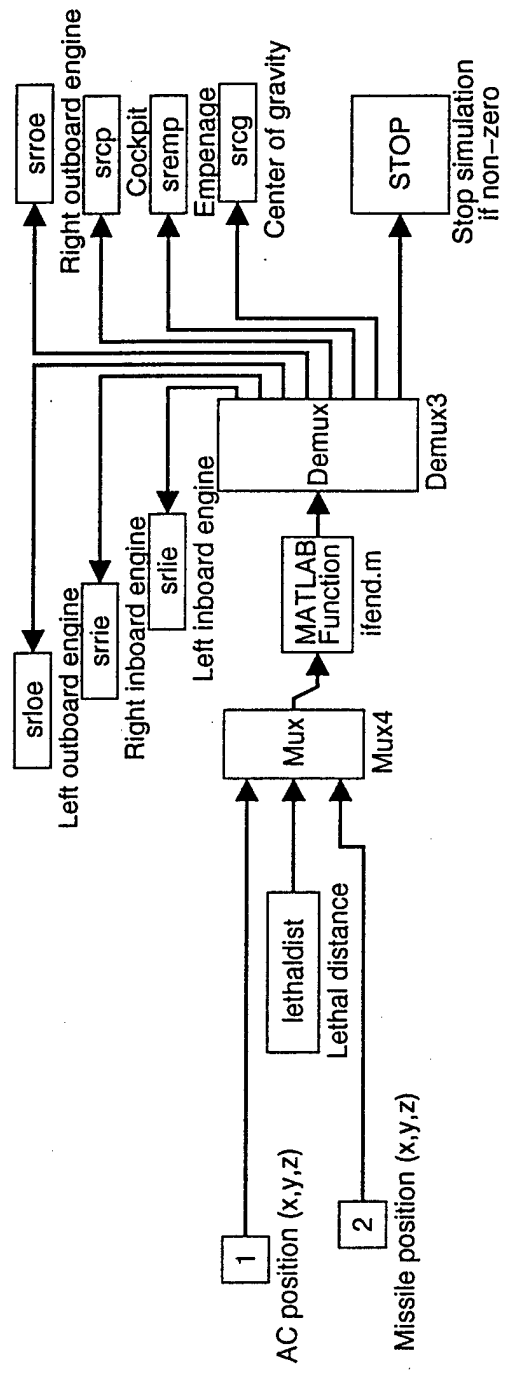

BLOCK: HitCheck

PAGE 35

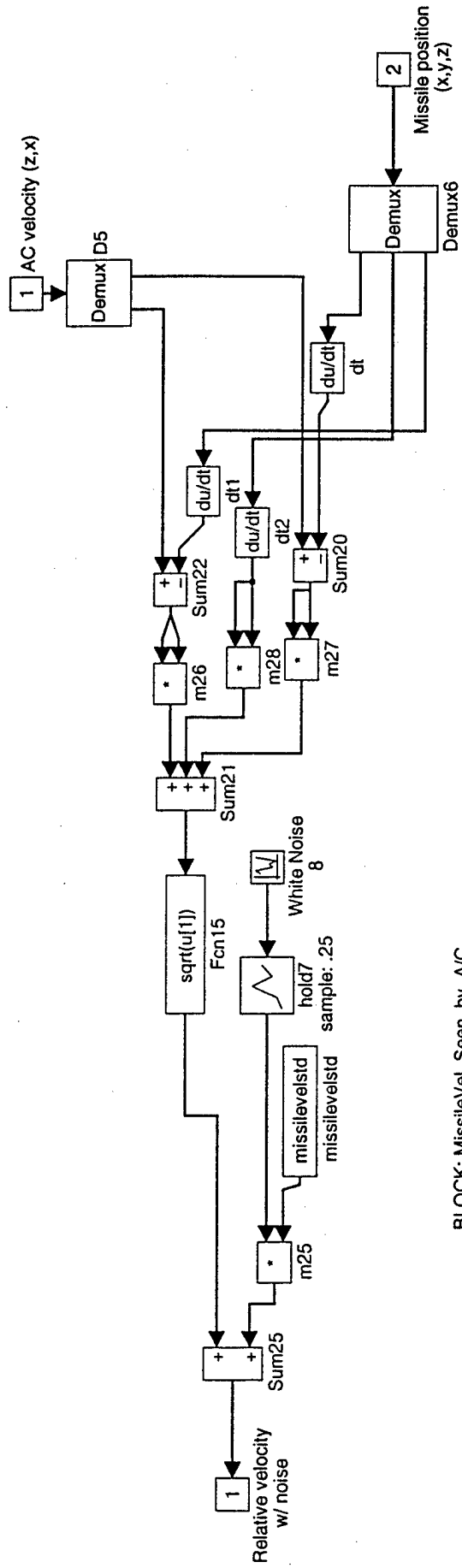

BLOCK: MissileVel_Seen_by_AC

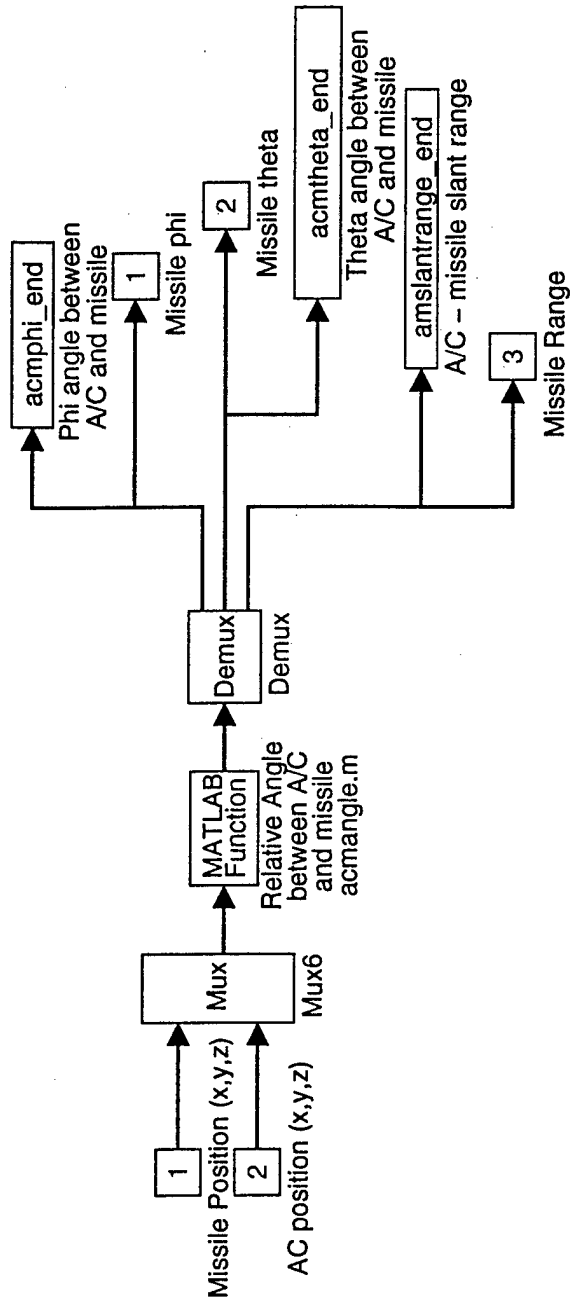

BLOCK: Relative_angles_and_range

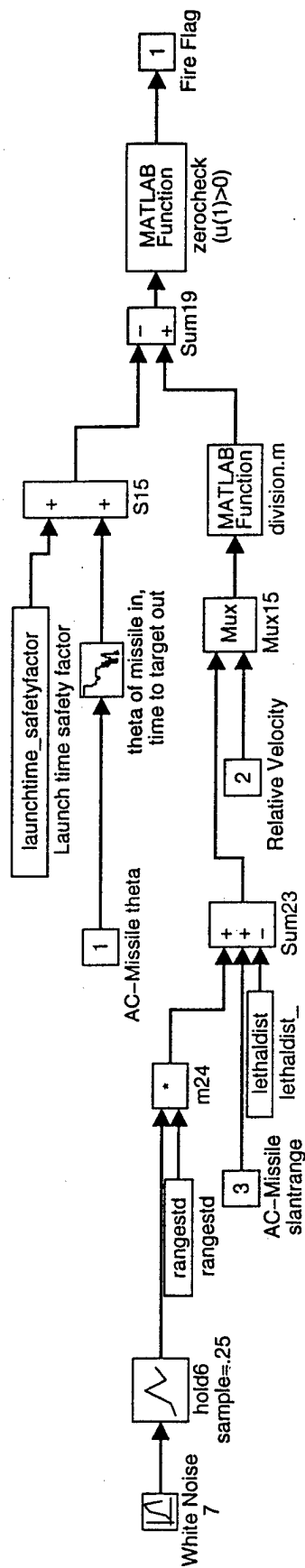

BLOCK: Fire_timing

PAGE 39

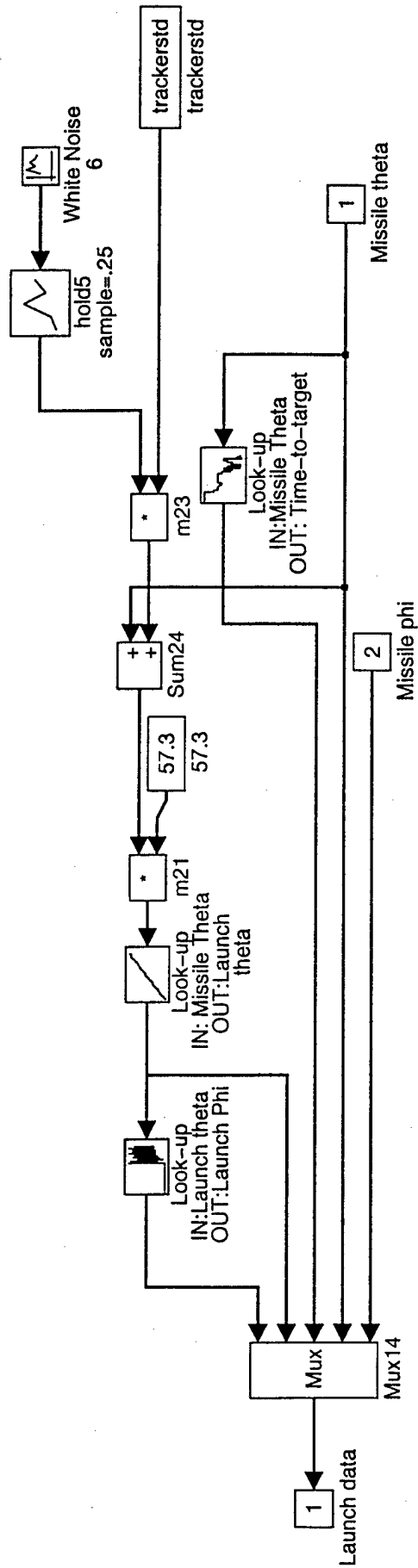

BLOCK: La:inch_data
PAGE 40

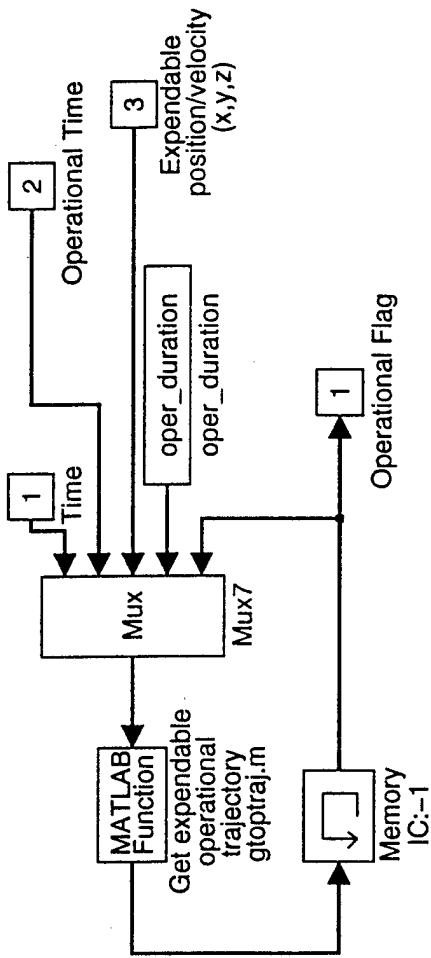

BLOCK: Go_operational

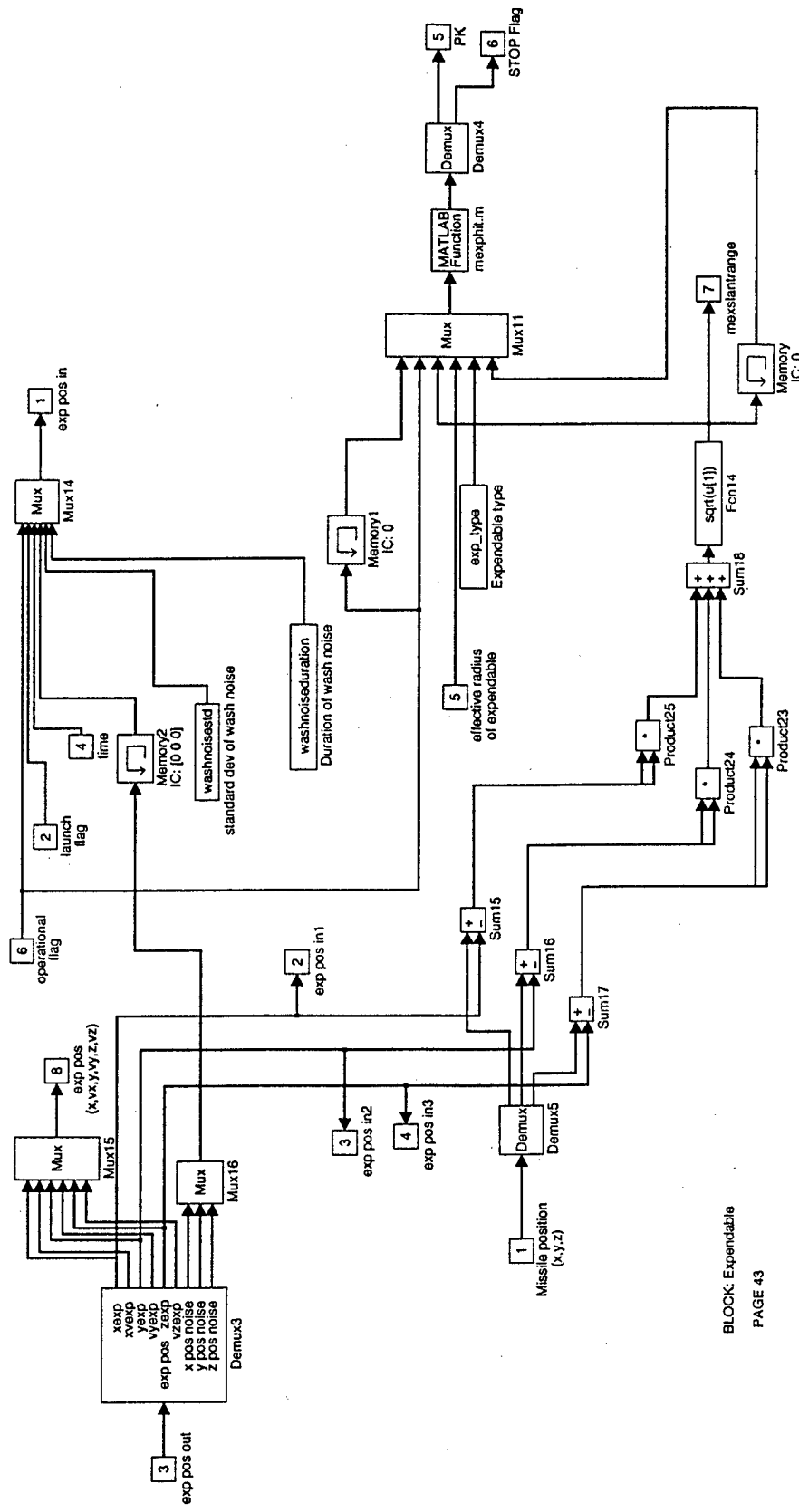

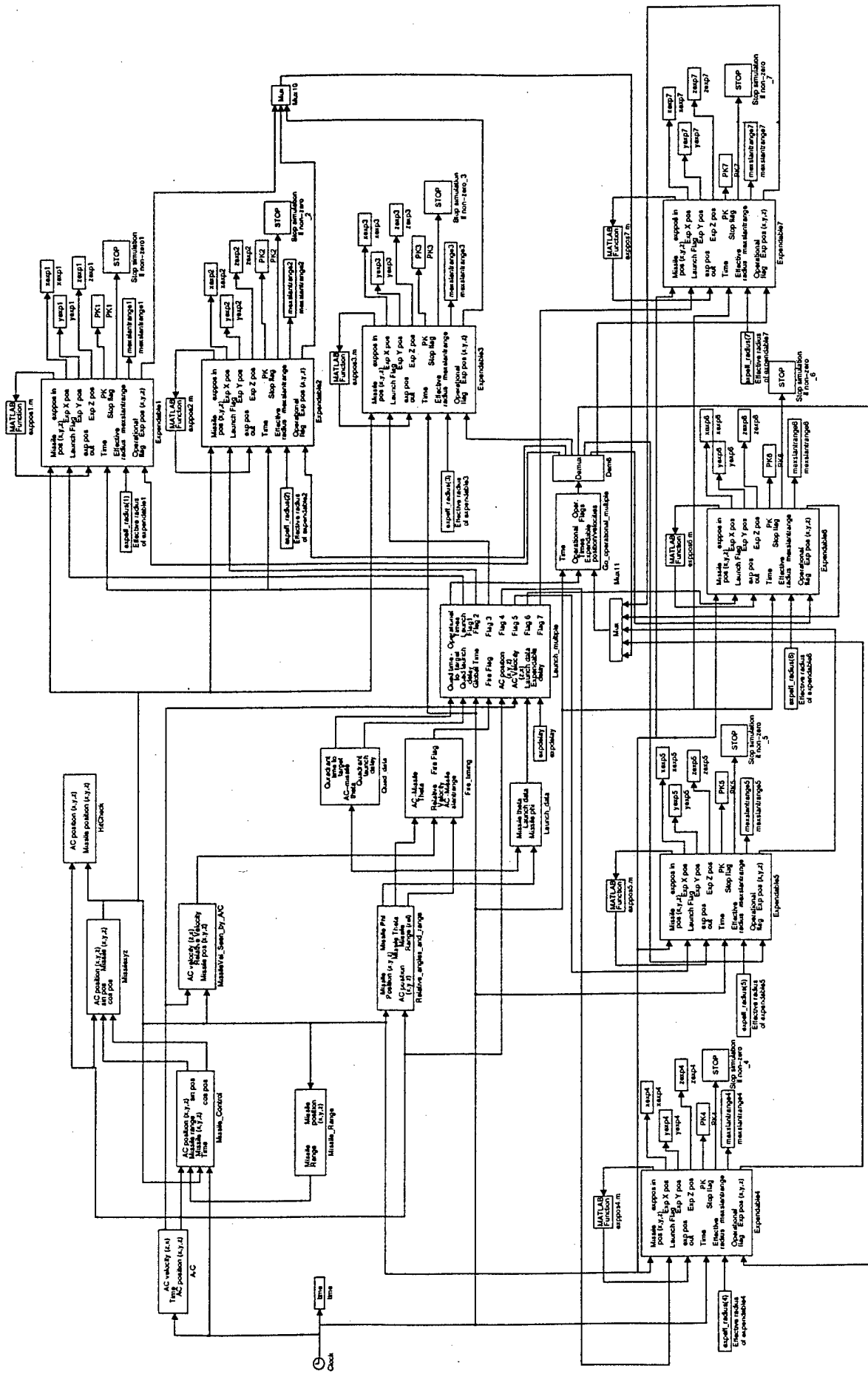

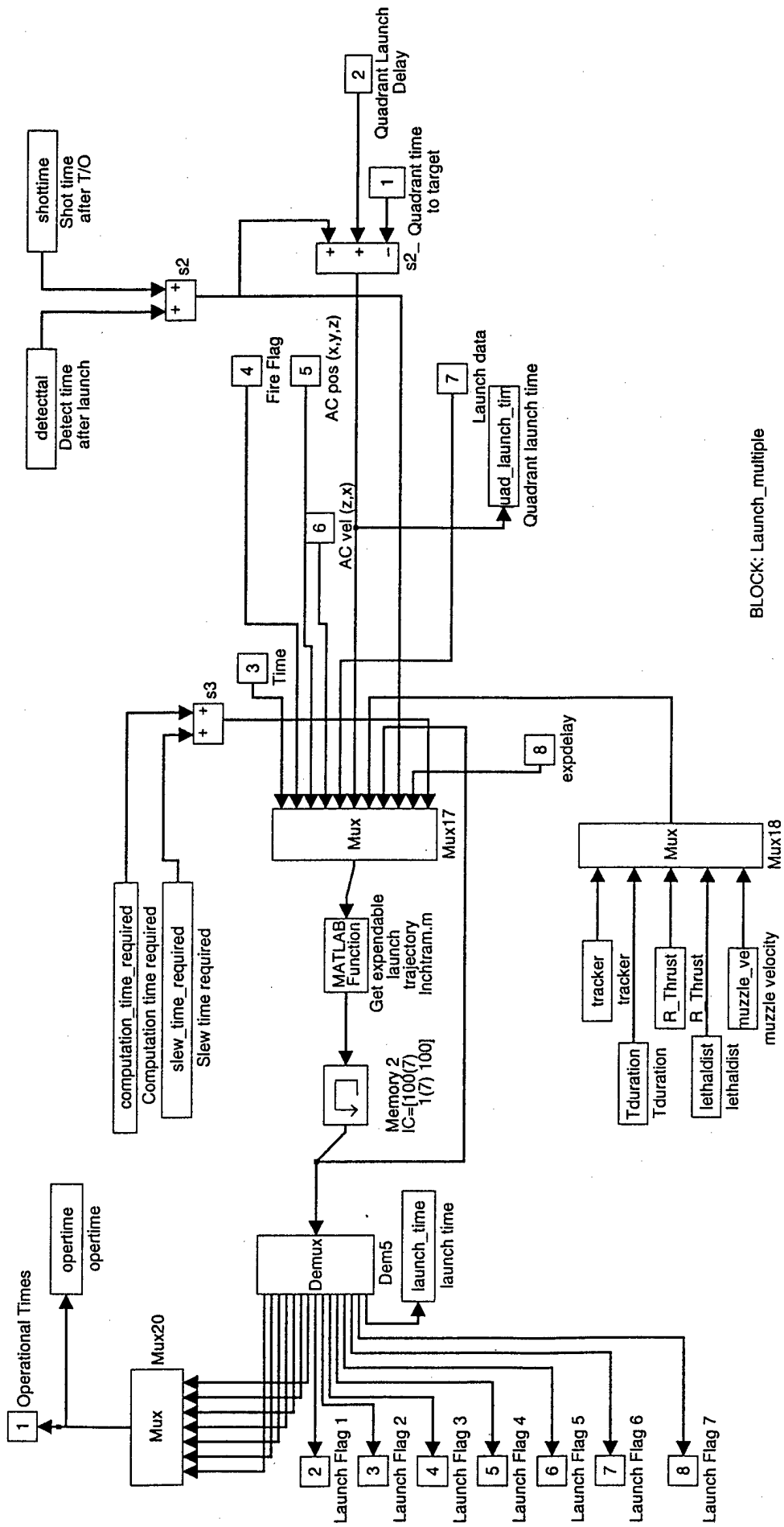

BLOCK: Launch_multiple

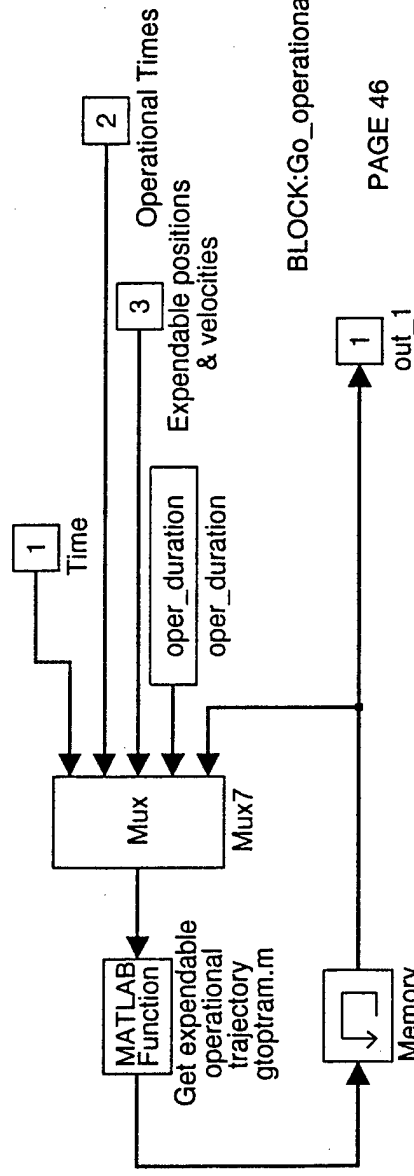

BLOCK:Go_operational_multiple

PAGE 46

IC: [-1 -1 -1 -1 -1 -1 -1 -1]

APPENDIX B

```
%*****  
% File: S.m  
% Top level file for ACME Simulation  
%  
% Authors: Capt. Joel Hagan & Capt Brian Peterson, USAF  
%          GSE-95D Air Force Institute of Technology  
% Language: Matlab  
% Project: AKKCT (Aircraft Kintetic Kill Countermeasures Technology)  
% Last Updated: 31 OCT 95  
%  
% Function: The simulation was initiated from a Matlab m-file, which is a script file of Matlab commands,  
% called S.m. This file contained system parameters which were changed often. For example, when a  
% sensitivity analysis was done on the effect of wash noise on PK, the wash noise parameters were put into  
% S.m for easy access. This file was run by typing 'S' and pressing return at the Matlab prompt while in the  
% directory of all of the ACME files.  
%  
%*****  
  
clear;  
  
tracker_type=5;      % tracker number (specify characteristics in tracker.m)  
exp_type=9;         % expendable number (specify characteristics in expdata.m &expdata1.m)  
outfilename='test.txt'; % file to output data to  
multiple=0;         % multiple expendable launches (1) or single launch (0)  
  
washnoisestd=[5 5 5]; % standard deviation of wash noise on [x y z] position  
                    % of expendable  
washnoiseduration=.05; % time that wash noise will affect expendable  
runs=1;              % number of time to runs simulation  
newmess;
```

```

%*****
% File: newmess.m
% Used in S.m
%
% Authors: Capt. Joel Hagan & Capt Brian Peterson, USAF
%         GSE-95D Air Force Institute of Technology
% Language: Matlab
% Project: AKKCT (Aircraft Kintetic Kill Countermeasures Technology)
% Last Updated: 31 OCT 95
%
% Function: Newmess.m is called from S.m. Newmess.m contains all of the system parameters which are
% rarely changed. If a analysis were to be done which called for a parameter to be changed often, it would
% have been moved to S.m. Likewise, if a parameter in S.m was not going to change often, it was moved
% back into the appropriate area in newmess.m in order to keep S.m simple.
% The parameters in newmess.m were organized by system or function. The global variables were
% declared first. Global variables were used for three processes: expendable trajectory look-up table
% calculation, prevention of redundant trajectory calculation, and recording the expendable launch time.
% These variables will be discussed further in the lchtraj.m discussion.
% The Scenario, Missile, and A/C parameters were next, followed by the tracker information. The
% tracker parameters which changed according to the tracker used were put into tracker.m due to the larger
% number of trackers which were used in the different stages of the Systems Engineering process. The
% expendable launch and launch timing were then followed by the expendable parameters. The look-up
% tables for the launch angles and timing were put into expdata.m due to their large size. Other expendable
% characteristics were put into expdata1.m due to the large number of expendables which were eventually
% developed. The rest of newmess.m was put into a loop to allow for Monte Carlo simulation runs. The
% parameters generated within the loop were generated randomly for each simulation run. The actual
% scenario parameters and detection timing were random processes, as were the noise which was put into
% the different system functions.
% Once all of the parameters were initialized, the simulation was run for a maximum of 25 seconds
% with a time interval of 0.001 seconds. The simulation was designed to end when the expendable hit the
% missile or the missile was within the lethal distance. If the simulation ran the full 25 second, the missile
% missed the aircraft.
% After the simulation was complete, the appropriate data was recorded by running records.m or
% recordm.m, depending on whether single or multiple expendable where launched. Likewise, the
% scenario was graphed by plotits.m or plotitm.m.
%
%*****

```

```

timestep=.001;
%Define global variables required in dqx.m--dqzt
global R_Thrust Phi_Angle Theta_Angle; %Define global variables required in dqx.m--dqzt
global CD_sphere CD_exp S_sphere S_exp W_sphere W_exp Rho_ambient
%Define global variables contained in ldelay.m
global computation_time_required slew_time_required time_to_target time_to_oper launch_delay
%
global Missile_Thrust M_Thrust MThrust_Duration Time_Global;
global CD_missile S_missile W_missile shottime xyzv;
%Define global variables used in exppos.m and lchtraj.m
if multiple
global expvxopr1 expvyopr1 expvzopr1 expvx1 expvy1 expvz1
global expvxopr2 expvyopr2 expvzopr2 expvx2 expvy2 expvz2
global expvxopr3 expvyopr3 expvzopr3 expvx3 expvy3 expvz3
global expvxopr4 expvyopr4 expvzopr4 expvx4 expvy4 expvz4
global expvxopr5 expvyopr5 expvzopr5 expvx5 expvy5 expvz5

```

```

global expvxopr6 expvyopr6 expvzopr6 expvx6 expvy6 expvz6
global expvxopr7 expvyopr7 expvzopr7 expvx7 expvy7 expvz7

else
  global expvx expvy expvz expvxopr expvyopr expvzopr
    %define variables needed to only run the ode's once each.
    %(SIMULINK runs every function twice but weonly need the odes results
    %(global) run once. These flags help do this
end
global onceitl onceito onceitm          % initialize flags to only run ode's once
global lnchtime lnchtimem              % intitalize expendable launch time variables

outfid=fopen(outfilename,'w');

% ***** SCENARIO INFORMATION

startshot=0; % define smallest angle the shooter (terrorist) may launch from
coverageshot=pi; % define the angular area from which the shooter may fire (Uniform distributed)
rangeshot=1000; % defin the average range from which the shooter will shoot (Rayliegh distributed)
averageshottime=2.5; % define the average time after A/C rotation that the shooter fires (Rayliegh dist.)

% ***** MISSILE INFORMATION

avg_missilevel=1451; %Define average missile velocity (ft/sec)
lethaldist=100; %Define lethal distance from A/C (ft)

%Define missile variables
Missile_Thrust=2500;
MThrust_Duration=2;
CD_missile=.3;
S_missile=.7854;
W_missile=25;

% ***** A/C INFORMATION

acclimbangle=.26; %Define A/C climb angle (rad)
acvel=258; %Define A/C Velocity (ft/sec)

% ***** DETECTOR/TRACKER INFORMATION
tracker; %see tracker.m

if multiple
  launchtime_safetyfactor=lsfm;
else
  launchtime_safetyfactor=lsfs;
end;

Average_detect_dist=3637.2; %define average range of detection of missile

```

% ***** LAUNCH INFORMATION

%Define whether or not the expendable is under thrust once it is launched
%based on the folowing three variables. If the expendable is under
%thrust once it is launched, R_Thrust and Tduration will have values
%other than zero and muzzle_vel will equal zero. In contrast, if the
%expendable is not under thust after being launched, R_Thrust and Tduration
%will equal zero and muzzle_vel will equal some positive value other than
%zero.

R_Thrust=0; %Define magnitude of thrust (lbf)
Tduration=0; %Define Duration of Expendable thrust (seconds)
muzzle_vel=700; %Define Muzzle velocity (ft/sec)
rear_shot_info=[135/57.3 .144]; % define angle and time to target for
front_shot_info=[45/57.3 .143]; % quadrant detector

% ***** LAUNCH TIMING INFORMATION

%Define computational time from when launch is detected to when
computation_time_required=.1; %expendable is launched (seconds)
%Define time required to slew launcher to proper launch angles
slew_time_required=.2; %phi and theta (seconds)
lnctime=100;
lnctimem=[100 100 100 100 100 100 100];

% ***** EXPENDABLE INFORMATION

%Define expendable type (1=an expendable with a constant effective radius, ie
%net,baloon, etc. 2=expendable with a decreasing effective radius, ie shot,
%"goop", etc.

Rho_ambient=.002378;
expdata; %run expdata.m to get lookup tables for expendable
expdata1;

%*****LOOP BEGINS

for pass=1:runs; % define number of runs
rand('seed',pass);
randn('seed',pass);

% ***** SCENARIO GENERATION

missiletheta=startshot+rand*coverageshot;
missilerange=3000+sqrt(-2*((rangeshot/(sqrt(pi/2)))^2)*log(rand));
if missilerange>9000
missilerange=9000;
end;
shottime=sqrt(-2*((averageshottime/(sqrt(pi/2)))^2)*log(rand));

% DETECTION TIMING

```

if imaging==1
    % define detection time (after missile launch)
    % imaging systems
    average_detecttal=.7;
    earliest_detecttal=.5;
    detecttal=earliest_detecttal+sqrt(-2*(((average_detecttal-earliest_detecttal)/(sqrt(pi/2)))^2)*log(rand));
else
    %Rotating systems
    rotation_rate=.5;
    earliest_detection=1;
    dummy=rand;
    if dummy<=.8
        missdelay=0;
    elseif dummy<=.95
        missdelay=rotation_rate;
    elseif dummy<=.99
        missdelay=2*rotation_rate;
    else missdelay=3*rotation_rate;
    end;

    detecttal=earliest_detection+missdelay+rand*rotation_rate;
end;
onceitm=0;
if multiple
    pct_radius(1,1)=(expeff_minpctradius+((1-expeff_minpctradius)*rand));
    pct_radius(1,2)=(expeff_minpctradius+((1-expeff_minpctradius)*rand));
    pct_radius(1,3)=(expeff_minpctradius+((1-expeff_minpctradius)*rand));
    pct_radius(1,4)=(expeff_minpctradius+((1-expeff_minpctradius)*rand));
    pct_radius(1,5)=(expeff_minpctradius+((1-expeff_minpctradius)*rand));
    pct_radius(1,6)=(expeff_minpctradius+((1-expeff_minpctradius)*rand));
    pct_radius(1,7)=(expeff_minpctradius+((1-expeff_minpctradius)*rand));
    expeff_radius=expeff_maxradius.*pct_radius;
    onceitl=[0 0 0 0 0 0 0];
    onceito=[0 0 0 0 0 0 0];

else
    pct_radius=(expeff_minpctradius+((1-expeff_minpctradius)*rand));
    expeff_radius=expeff_maxradius*pct_radius;
    onceitl=0;
    onceito=0;
end;

% ***** NOISE GENERATION INFORMATION
    %Define variables required to inject noise into the simulation

noiseseed=randn(9,1);

    % noise sampled every second
acvelstd=6.7; %standard deviation of noise on A/C velocity (99% of noise points will be within +/- 3x this
(ft/s)
acangstd=.16/57.3; %same as above but is for climb angle (radians)
acystd=5; %same as above but is for y position (ft)

AcquireNstd=.75/57.3; %noise in missiles knowledge of where the A/C is (sampled every .1 sec) (radians)

```

```
MThrustNstd=.01; % noise in missiles flight commands and execution (percent of command)
accrosswind=0; % feet the A/C drifts in the w direction every second
```

```
%*****SIMULATION RUN
```

```
%Run simulation
```

```
if multiple
```

```
    [t,x,y]=linsim('acmeblcm',[0 25],[],[.001,.001,.001]);
```

```
else
```

```
    [t,x,y]=linsim('acmeblck',[0 25],[],[.001,.001,.001]);
```

```
end;
```

```
%Define point in space where missile intersects lethal sphere
```

```
sizethetamissile_end=size(acmtheta_end);
```

```
thetamissile_at_end=acmtheta_end(sizethetamissile_end(1,1));
```

```
phimissile_at_end=acmphi_end(sizethetamissile_end(1,1));
```

```
amslanrange_at_end=amslanrange_end(sizethetamissile_end(1,1));
```

```
    acx_at_end=xac(sizethetamissile_end(1,1));
```

```
    acy_at_end=yac(sizethetamissile_end(1,1));
```

```
    acz_at_end=zac(sizethetamissile_end(1,1));
```

```
    x_actual_hit=acx_at_end+amslanrange_at_end*sin(phimissile_at_end)*cos(thetamissile_at_end);
```

```
    y_actual_hit=acy_at_end+amslanrange_at_end*sin(phimissile_at_end)*cos(thetamissile_at_end);
```

```
    z_actual_hit=acz_at_end+amslanrange_at_end*cos(phimissile_at_end);
```

```
if multiple
```

```
    recordm
```

```
    plotitm
```

```
else
```

```
    records
```

```
    plotits
```

```
end
```

```
end
```

```
status=fclose(outfid);
```

```

%*****
% File: tracker.m
% Used in newmess.m
%
% Authors: Capt. Joel Hagan & Capt Brian Peterson, USAF
%         GSE-95D Air Force Institute of Technology
% Language: Matlab
% Project: AKKCT (Aircraft Kintetic Kill Countermeasures Technology)
% Last Updated: 31 OCT 95
%
% Function: this function contains the statements which define the system parameters
%         for the different trackers.
%
%*****
if tracker_type==0      %DETECTOR ONLY
    tracker=0;          %Define if there is a tracker on-board the A/C, 1 for yes or 0 for no.
    trackerstd=pi/8;    %Define tracker angular error i.e. 1 means +/-3 degrees (99 % of the time)
                        % (irrelevant here)
    rangestd=600;       %Define tracker range error i.e. 2 means +/-6 feet (99% of the time)
                        % (irrelevant here)
    missilelevelstd=600; %Define tracker error for velocity of missil 2 means 6 ft/s
                        % (irrelevant here)
    launchtime_safetyfactor=3; %Define launch time safety factor when a tracker is on-board the A/C
    imaging=1;          %define wether detector is imaging or gimbelled (1=imaging 0= rotating)
    expdelay=.2;        %Define time interval between expendable salvos
    lsfs=.75;
    lsfm=.75;

elseif tracker_type==1 %TRACKER 1 (BAD)
    tracker=1;          %Define if there is a tracker on-board the A/C, 1 for yes or 0 for no.
    trackerstd=2/57.3;  %Define tracker angular error i.e. 1 means +/-3 degrees (99 % of the time)
    rangestd=400;       %Define tracker range error i.e. 2 means +/-6 feet (99% of the time)
    missilelevelstd=15; %Define tracker error for velocity of missil 2 means 6 ft/s
    lsfs=.75;          % launch safety factor for single launch
    lsfm=.75;          % launch safety factor for multiple launch
    imaging=1;
    expdelay=.2; %Define time interval between expendable salvos
elseif tracker_type==2 %TRACKER 2 (OK)
    tracker=1;
    trackerstd=.333/57.3;
    rangestd=300;
    missilelevelstd=10;
    lsfs=.5;
    lsfm=.5;
    imaging=1;
    expdelay=.2; %Define time interval between expendable salvos
elseif tracker_type==3 %TRACKER 3 (GOOD)
    tracker=1;
    trackerstd=(1/60)/57.3;
    rangestd=5;
    missilelevelstd=2;
    lsfs=.01;
    lsfm=.15;
    imaging=1;
    expdelay=.05; %Define time interval between expendable salvos

```

```
elseif tracker_type==4    %TRACKER 4 TRW
    tracker=1;
    trackerstd=(1/6)/57.3;
    rangestd=2;
    missilelevelstd=1/3;
    lsfs=.01;
    lsfm=.15;
    imaging=1;
    expdelay=.05; %Define time interval between expendable salvos
elseif tracker_type==5    %TRACKER 5 AAR-54 with ranging antenna
    tracker=1;
    trackerstd=(1/3)/57.3;
    rangestd=5;
    missilelevelstd=2;
    lsfs=.01;
    lsfm=.15;
    imaging=1;
    expdelay=.05; %Define time interval between expendable salvos
elseif tracker_type==6    %TRACKER 5 AAR-54 with ranging antenna with larger delay
    tracker=1;
    trackerstd=(1/3)/57.3;
    rangestd=5;
    missilelevelstd=2;
    lsfs=.07;
    lsfm=.15;
    imaging=1;
    expdelay=.05; %Define time interval between expendable salvos

end;
```

```
% EXPDATA.m
```

```
%*****
```

```
% file: expdata.m
```

```
% Used in newmess.m
```

```
%
```

```
% Authors: Capt. Joel Hagan & Capt Brian Peterson, USAF
```

```
% GSE-95D Air Force Institute of Technology
```

```
% Language: Matlab
```

```
% Project: AKKCT (Aircraft Kintetic Kill Countermeasures Technology)
```

```
% Last Updated: 14 SEP 95
```

```
%
```

```
% Function: This initializes the look-up tables and other constants
```

```
% for the expendable type to be used in the simulation.
```

```
% The look-up tables are generated using getit.m
```

```
%
```

```
% exp_type
```

```
% 1 iteration 2 Cherry bomb
```

```
% 2 iteration 2 DET NET
```

```
% 3 iteration 2 LEADS
```

```
% 4 iteration 2 SpecNet
```

```
% 5 iteration 2 Airbag
```

```
% 6 iteration 3 Cherry Bomb
```

```
% 7 iteration 3 DET NET
```

```
% 8 iteration 3 SpecNet
```

```
% 9 enlarged DET NET
```

```
%
```

```
%*****
```

```
if lethaldist==100
```

```
if exp_type==1 %CHERRY BOMB
```

```
    %Define properties of expendable and sphere
```

```
        %Sphere
```

```
            W_sphere=25; %weight of the capsule holding the expendable
```

```
            CD_sphere=.15; % general sphere information
```

```
            S_sphere=.196;
```

```
        %Expendable
```

```
            CD_exp=.38;
```

```
            S_exp=.006944;
```

```
            W_exp=.238;
```

```
        %Define vectors to be used to determine expendable launch angle
```

```
        %if there is a tracker on the A/C
```

```
%Define time required for expendable to get to target point on lethal sphere
```

```
time_lu(1:10)=[.1436 .1436 .1436 .1436 .1436 .1436 .1436 .1436 .1436 .1436];
```

```
time_lu(11:20)=[.1436 .1436 .1436 .1436 .1436 .1436 .1436 .1436 .1436 .1436];
```

```
time_lu(21:30)=[.1436 .1436 .1436 .1435 .1435 .1435 .1435 .1435 .1435 .1435];
```

```
time_lu(31:40)=[.1435 .1435 .1435 .1435 .1435 .1435 .1435 .1435 .1435 .1435];
```

```

time_lu(41:50)=[.1435 .1435 .1435 .1435 .1435 .1435 .1435 .1435 .1435 .1435];
time_lu(51:60)=[.1435 .1435 .1435 .1435 .1434 .1434 .1434 .1434 .1434 .1434];
time_lu(61:70)=[.1434 .1434 .1434 .1434 .1434 .1434 .1434 .1434 .1434 .1434];
time_lu(71:80)=[.1434 .1434 .1434 .1434 .1433 .1433 .1433 .1433 .1433 .1433];
time_lu(81:90)=[.1433 .1433 .1433 .1433 .1433 .1433 .1433 .1433 .1433 .1433];
time_lu(91:100)=[.1433 .1433 .1433 .1433 .1432 .1432 .1432 .1432 .1432 .1432];
time_lu(101:110)=[.1432 .1432 .1432 .1432 .1432 .1432 .1432 .1432 .1432 .1431];
time_lu(111:120)=[.1431 .1431 .1431 .1431 .1431 .1431 .1431 .1431 .1428 .1428];
time_lu(121:130)=[.1428 .1428 .1432 .1428 .1431 .1427 .1431 .1431 .1427 .1432];
time_lu(131:140)=[.1430 .1431 .1432 .1429 .1432 .1432 .1428 .1431 .1430 .1431];
time_lu(141:150)=[.1431 .1427 .1427 .1426 .1430 .1430 .1432 .1431 .1430 .1432];
time_lu(151:160)=[.1428 .1427 .1427 .1431 .1431 .1427 .1432 .1431 .1433 .1427];
time_lu(161:170)=[.1433 .1427 .1432 .1432 .1432 .1432 .1428 .1428 .1428 .1426];
time_lu(171:181)=[.1427 .1428 .1428 .1427 .1427 .1428 .1427 .1428 .1427 .1427];

```

```

%Define angle at which missile is coming at aircraft. This will always be 0-180 by 1 as shown below
theta_missile_lu=[0 1 2 3 4 5 6 7 8 9 10 11 12 13 14 15 16 17 18 19 20 21 22 23 24 25 26 27 28 29 30 31
32 33 34 35 36 37 38 39 40 41 42 43 44 45 46 47 48 49 50 51 52 53 54 55 56 57 58 59 60 61 62 63 64 65
66 67 68 69 70 71 72 73 74 75 76 77 78 79 80 81 82 83 84 85 86 87 88 89 90 91 92 93 94 95 96 97 98 99
100 101 102 103 104 105 106 107 108 109 110 111 112 113 114 115 116 117 118 119 120 121 122 123
124 125 126 127 128 129 130 131 132 133 134 135 136 137 138 139 140 141 142 143 144 145 146 147
148 149 150 151 152 153 154 155 156 157 158 159 160 161 162 163 164 165 166 167 168 169 170 171
172 173 174 175 176 177 178 179 180];

```

```

%Define angle at which launcher should be aimed corresponding to the angle at which the missile is
%coming at the aircraft shown above
theta_launch_lu=[0 1 2 3 4 5 6 7 8 9 10 11 12 13 14 15 16 17 18 19 20 21 22 23 24 25 26 27 28 29 30 31
32 33 34 35 36 37 38 39 40 41 42 43 44 45 46 47 48 49 50 51 52 53 54 55 56 57 58 59 60 61 62 63 64 65
66 67 68 69 70 71 72 73 74 75 76 77 78 79 80 81 82 83 84 85 86 87 88 89 90 91 92 93 94 95 96 97 98 99
100 101 102 103 104 105 106 107 108 109 110 111 112 113 114 115 116 117 118 119 120 121 122 123
124 125 126 127 128 129 130 131 132 133 134 135 136 137 138 139 140 141 142 143 144 145 146 147
148 149 150 151 152 153 154 155 156 157 158 159 160 161 162 163 164 165 166 167 168 169 170 171
172 173 174 175 176 177 178 179 180];

```

```

phi_launch_lu(1:10)=[93.12 93.12 93.12 93.12 93.12 93.12 93.12 93.12 93.12 93.12];
phi_launch_lu(11:20)=[93.12 93.12 93.12 93.12 93.12 93.12 93.12 93.12 93.12 93.12];
phi_launch_lu(21:30)=[93.12 93.12 93.12 93.12 93.12 93.12 93.12 93.12 93.12 93.12];
phi_launch_lu(31:40)=[93.12 93.12 93.12 93.12 93.12 93.12 93.12 93.12 93.12 93.12];
phi_launch_lu(41:50)=[93.12 93.12 93.12 93.12 93.12 93.12 93.12 93.12 93.12 93.12];
phi_launch_lu(51:60)=[93.12 93.12 93.12 93.12 93.12 93.12 93.12 93.12 93.12 93.12];
phi_launch_lu(61:70)=[93.12 93.12 93.12 93.12 93.12 93.12 93.12 93.12 93.12 93.12];
phi_launch_lu(71:80)=[93.12 93.12 93.12 93.12 93.12 93.12 93.12 93.12 92.92 92.92];
phi_launch_lu(81:90)=[92.917 92.916 92.915 92.914 92.913 92.912 92.911 92.910 92.909 92.907];
phi_launch_lu(91:100)=[92.906 92.905 92.904 92.902 92.901 92.900 92.898 92.897 92.896 92.894];
phi_launch_lu(101:110)=[92.893 92.891 92.890 92.888 92.886 92.885 92.883 92.882 92.880 92.878];
phi_launch_lu(111:120)=[92.876 92.875 92.873 92.871 92.869 92.867 92.865 92.863 92.861 92.859];
phi_launch_lu(121:130)=[93.081 93.021 93.224 93.140 93.219 93.030 92.901 92.764 92.995 93.068];
phi_launch_lu(131:140)=[92.825 92.947 93.061 93.036 92.873 93.062 92.895 93.086 92.899 92.919];
phi_launch_lu(141:150)=[92.917 92.809 92.806 92.804 92.801 92.799 92.866 92.887 93.093 92.893];
phi_launch_lu(151:160)=[93.047 92.912 92.840 93.066 92.866 93.060 92.891 92.879 93.042 92.874];
phi_launch_lu(161:170)=[92.959 92.844 92.842 92.887 92.915 92.868 93.038 92.841 93.051 92.840];
phi_launch_lu(171:181)=[92.904 92.861 92.839 92.893 92.855 92.851 93.066 92.861 92.953 92.823
92.831];

```

```

elseif exp_type==2;

```

%DETNET

%Define properties of expendable and sphere

%Sphere

W_sphere=10;
CD_sphere=.15; % general sphere information
S_sphere=.196;

%Expendable

CD_exp=1.16;
S_exp=46.15;
W_exp=6.87;

%Define vectors to be used to determine expendable launch angle

%if there is a tracker on the A/C

%Define time required for expendable to get to target point on lethal sphere

time_lu1=[.144 .144 .144 .144 .144 .144 .144 .144 .144 .144];
time_lu2=[.144 .144 .144 .144 .144 .144 .144 .144 .144 .144];
time_lu3=[.144 .144 .144 .144 .144 .144 .144 .144 .144 .144];
time_lu4=[.144 .144 .144 .144 .144 .144 .144 .144 .144 .144];
time_lu5=[.144 .144 .144 .144 .144 .144 .144 .144 .144 .144];
time_lu6=[.144 .144 .144 .144 .144 .144 .144 .144 .144 .144];
time_lu7=[.144 .144 .144 .144 .144 .144 .144 .144 .144 .144];
time_lu8=[.144 .144 .144 .144 .144 .144 .144 .144 .144 .144];
time_lu9=[.144 .144 .144 .144 .144 .144 .144 .144 .144 .144];
time_lu11=[.144 .144 .144 .144 .144 .144 .144 .144 .144 .144];
time_lu10=[.144 .144 .144 .144 .144 .144 .144 .144 .144 .144];
time_lu12=[.144 .144 .144 .144 .143 .143 .143 .143 .143 .143];
time_lu13=[.143 .143 .143 .143 .143 .143 .143 .143 .143 .143];
time_lu14=[.143 .143 .143 .143 .143 .143 .143 .143 .143 .143];
time_lu15=[.143 .143 .143 .143 .143 .143 .143 .143 .143 .143];
time_lu16=[.143 .143 .143 .143 .143 .143 .143 .143 .143 .143];
time_lu17=[.143 .143 .143 .143 .143 .143 .143 .143 .143 .143];
time_lu18=[.143 .143 .143 .143 .143 .143 .143 .143 .143 .143];
time_lu=[time_lu1 time_lu2 time_lu3 time_lu4 time_lu5 time_lu6 time_lu7 time_lu8 time_lu9 time_lu10
time_lu11 time_lu12 time_lu13 time_lu14 time_lu15 time_lu16 time_lu17 time_lu18];

%Define angle at which missile is coming at aircraft. This will always be 0-180 by 1 as shown below

theta_missile_lu=[0 1 2 3 4 5 6 7 8 9 10 11 12 13 14 15 16 17 18 19 20 21 22 23 24 25 26 27 28 29 30 31
32 33 34 35 36 37 38 39 40 41 42 43 44 45 46 47 48 49 50 51 52 53 54 55 56 57 58 59 60 61 62 63 64 65
66 67 68 69 70 71 72 73 74 75 76 77 78 79 80 81 82 83 84 85 86 87 88 89 90 91 92 93 94 95 96 97 98 99
100 101 102 103 104 105 106 107 108 109 110 111 112 113 114 115 116 117 118 119 120 121 122 123
124 125 126 127 128 129 130 131 132 133 134 135 136 137 138 139 140 141 142 143 144 145 146 147
148 149 150 151 152 153 154 155 156 157 158 159 160 161 162 163 164 165 166 167 168 169 170 171
172 173 174 175 176 177 178 179 180];

%Define angle at which launcher should be aimed corresponding to the angle at which the missile is

%coming at the aircraft shown above

theta_launch_lu1=[0 1 2 3 4 5 6 7 8 9];
theta_launch_lu2=[10 11 12 13 14 15 16 17 18 19];
theta_launch_lu3=[20 21 22 23 24 25 26 27 28 29];
theta_launch_lu4=[30 31 32 33 34 35 36 37 38 39];

```

theta_launch_lu5=[40 41 42 43 44 45 46 47 48 49];
theta_launch_lu6=[50 51 52 53 54 55 56 57 58 59];
theta_launch_lu7=[60 61 62 63 64 65 66 67 68 69];
theta_launch_lu8=[70 71 72 73 74 75 76 77 78 79];
theta_launch_lu9=[80 81 82 83 84 85 86 87 88 89];
theta_launch_lu10=[90 91 92 93 94 95 96 97 98 99];
theta_launch_lu11=[100 101 102 103 104 105 106 107 108 109];
theta_launch_lu12=[110 111 112 113 114 114.796 115.796 116.791 117.787 118.782 119.779];
theta_launch_lu13=[120.775 121.772 122.770 123.767 124.765 125.764 126.763 127.762 128.762];
theta_launch_lu14=[129.985 130.847 131.861 133.032 133.972 134.794 135.86 136.927 137.89 139.069];
theta_launch_lu15=[139.910 140.926 141.855 142.891 144.075 145 146 147 148 148.941];
theta_launch_lu16=[149.881 151.124 151.999 152.997 154.087 154.909 155.952 156.942 158.189
158.898];
theta_launch_lu17=[159.894 160.954 161.995 162.958 163.937 165.019 166.076 167.018 168.016
169.023];
theta_launch_lu18=[170.061 171.237 172.180 173.056 174.067 175.088 176.204 176.944 178.127
178.961 180.058];
theta_launch_lu=[theta_launch_lu1 theta_launch_lu2 theta_launch_lu3 theta_launch_lu4 theta_launch_lu5
theta_launch_lu6 theta_launch_lu7 theta_launch_lu8 theta_launch_lu9 theta_launch_lu10
theta_launch_lu11 theta_launch_lu12 theta_launch_lu13 theta_launch_lu14 theta_launch_lu15
theta_launch_lu16 theta_launch_lu17 theta_launch_lu18];

```

```

%Define phi angle at which launcher should be aimed in order to hit missile.
phi_launch_lu1=[93.12 93.12 93.12 93.12 93.12 93.12 93.12 93.12 93.12 93.12 93.12];
phi_launch_lu2=[93.12 93.12 93.12 93.12 93.12 93.12 93.12 93.12 93.12 93.12 93.12];
phi_launch_lu3=[93.12 93.12 93.12 93.12 93.12 93.12 93.12 93.12 93.12 93.12 93.12];
phi_launch_lu4=[93.12 93.12 93.12 93.12 93.12 93.12 93.12 93.12 93.12 93.12 93.12];
phi_launch_lu5=[93.12 93.12 93.12 93.12 93.12 93.12 93.12 93.12 93.12 93.12 93.12];
phi_launch_lu6=[93.12 93.12 93.12 93.12 93.12 93.12 93.12 93.12 93.12 93.12 93.12];
phi_launch_lu7=[93.12 93.12 93.12 93.12 93.12 93.12 93.12 93.12 93.12 93.12 93.12];
phi_launch_lu8=[93.12 93.12 93.12 93.12 93.12 93.12 93.12 93.12 93.12 93.12 93.12];
phi_launch_lu9=[93.12 93.12 93.12 93.12 93.12 92.92 92.92 92.92 92.92 92.92 92.91];
phi_launch_lu10=[92.912 92.911 92.910 92.909 92.907 92.906 92.905 92.904 92.902 92.901];
phi_launch_lu11=[92.899 92.898 92.897 92.895 92.893 92.892 92.890 92.889 92.887 92.885];
phi_launch_lu12=[92.884 92.882 92.880 92.878 92.876 92.874 92.872 92.870 92.868 92.866];
phi_launch_lu13=[92.864 92.862 92.860 92.857 92.855 92.853 92.851 92.848 92.846 92.844];
phi_launch_lu14=[93.069 93.013 92.816 92.822 93.006 92.831 93.013 93.025 92.811 92.922];
phi_launch_lu15=[92.899 93.088 92.901 93.030 92.910 92.804 92.801 92.799 92.797 93.013];
phi_launch_lu16=[92.841 92.834 92.832 92.868 92.879 92.836 92.874 92.879 93.044 92.869];
phi_launch_lu17=[93.028 92.853 92.877 92.823 92.827 93.016 92.827 92.858 92.866 92.865];
phi_launch_lu18=[93.053 92.840 92.898 92.866 92.870 92.904 92.876 92.854 93.024 93.005 92.826];
phi_launch_lu=[phi_launch_lu1 phi_launch_lu2 phi_launch_lu3 phi_launch_lu4 phi_launch_lu5
phi_launch_lu6 phi_launch_lu7 phi_launch_lu8 phi_launch_lu9 phi_launch_lu10 phi_launch_lu11
phi_launch_lu12 phi_launch_lu13 phi_launch_lu14 phi_launch_lu15 phi_launch_lu16 phi_launch_lu17
phi_launch_lu18];
elseif exp_type==3
%PHALANX
%Define properties of expendable and sphere
%Sphere
W_sphere=.22;
CD_sphere=.15; % general sphere information
S_sphere=.196;

%Expendable
CD_exp=.38;

```

```

S_exp=.00338;
W_exp=.22;
%Define vectors to be used to determine expendable launch angle
%if there is a tracker on the A/c

%Define time required for expendable to get to target point on lethal sphere
time_lu1=[.1457 .1457 .1457 .1457 .1457 .1457 .1457 .1457 .1457 .1457];
time_lu2=[.1456 .1456 .1456 .1456 .1456 .1456 .1455 .1455 .1455 .1454];
time_lu3=[.1454 .1454 .1454 .1453 .1453 .1453 .1452 .1452 .1452 .1452];
time_lu4=[.1451 .1451 .1451 .1448 .1448 .1448 .1448 .1447 .1448 .1448];
time_lu5=[.1447 .1447 .1447 .1447 .1447 .1447 .1446 .1446 .1446 .1446];
time_lu6=[.1446 .1446 .1446 .1446 .1445 .1445 .1445 .1445 .1445 .1445];
time_lu7=[.1445 .1445 .1445 .1445 .1445 .1445 .1445 .1445 .1445 .1444];
time_lu8=[.1444 .1444 .1444 .1444 .1444 .1444 .1445 .1445 .1445 .1445];
time_lu9=[.1445 .1445 .1445 .1445 .1445 .1445 .1445 .1445 .1445 .1445];
time_lu11=[.1445 .1445 .1445 .1445 .1445 .1445 .1444 .1444 .1444 .1444];
time_lu10=[.1444 .1444 .1444 .1444 .1444 .1444 .1444 .1444 .1444 .1444];
time_lu12=[.1443 .1443 .1440 .1440 .1440 .1440 .1440 .1440 .1440 .1440];
time_lu13=[.1440 .1440 .1440 .1440 .1440 .1437 .1436 .1436 .1435 .1435];
time_lu14=[.1435 .1434 .1434 .1434 .1433 .1433 .1433 .1433 .1432 .1432];
time_lu15=[.1432 .1432 .1431 .1431 .1431 .1431 .1431 .1432 .1432 .1432];
time_lu16=[.1432 .1432 .1431 .1431 .1431 .1436 .1431 .1431 .1436 .1437];
time_lu17=[.1436 .1436 .1436 .1436 .1435 .1436 .1437 .1436 .1436 .1436];
time_lu18=[.1436 .1436 .1437 .1436 .1436 .1436 .1437 .1437 .1436 .1436];
time_lu=[time_lu1 time_lu2 time_lu3 time_lu4 time_lu5 time_lu6 time_lu7 time_lu8 time_lu9 time_lu10
time_lu11 time_lu12 time_lu13 time_lu14 time_lu15 time_lu16 time_lu17 time_lu18];

%Define angle at which missile is coming at aircraft. This will always be 0-180 by 1 as shown below
theta_missile_lu=[0 1 2 3 4 5 6 7 8 9 10 11 12 13 14 15 16 17 18 19 20 21 22 23 24 25 26 27 28 29 30 31
32 33 34 35 36 37 38 39 40 41 42 43 44 45 46 47 48 49 50 51 52 53 54 55 56 57 58 59 60 61 62 63 64 65
66 67 68 69 70 71 72 73 74 75 76 77 78 79 80 81 82 83 84 85 86 87 88 89 90 91 92 93 94 95 96 97 98 99
100 101 102 103 104 105 106 107 108 109 110 111 112 113 114 115 116 117 118 119 120 121 122 123
124 125 126 127 128 129 130 131 132 133 134 135 136 137 138 139 140 141 142 143 144 145 146 147
148 149 150 151 152 153 154 155 156 157 158 159 160 161 162 163 164 165 166 167 168 169 170 171
172 173 174 175 176 177 178 179 180];

%Define angle at which launcher should be aimed corresponding to the angle at which the missile is
%coming at the aircraft shown above
theta_launch_lu1=[0 1 2 3 4 5 6 7 8 9];
theta_launch_lu2=[10 11 12 13 14 15 16 16.799 17.792 18.793];
theta_launch_lu3=[19.787 20.781 21.776 22.772 23.767 24.764 25.798 26.796 27.794 28.793];
theta_launch_lu4=[29.792 30.792 31.792 32.793 33.794 34.795 35.796 36.798 37.759 38.762];
theta_launch_lu5=[39.764 40.768 41.771 42.775 43.779 44.784 45.788 46.793 47.798 49];
theta_launch_lu6=[50 51 52 53 54 55 56 57 58 59];
theta_launch_lu7=[60 61 62 63 64 65 66 67 68 69];
theta_launch_lu8=[70 71 72 73 74 75 76 77 78 79];
theta_launch_lu9=[80 81 82 83 84 85 86 87 88 89];
theta_launch_lu10=[90 91 92 93 94 95 96 97 98 99];
theta_launch_lu11=[100 101 102 103 104 105 106 107 107.798 108.789];
theta_launch_lu12=[109.780 110.771 112 112.797 113.791 114.782 115.772 116.764 117.756 118.784];
theta_launch_lu13=[119.742 120.736 121.730 122.726 123.721 124.718 125.716 126.714 127.712
128.712];
theta_launch_lu14=[129.712 130.713 131.715 132.717 133.720 134.724 135.728 136.733 137.738
138.745];

```

```

theta_launch_lu15=[139.751 140.759 141.766 142.775 143.783 144.792 145.876 147 148 149];
theta_launch_lu16=[150 151 152 153 153.954 154.925 155.887 156.949 158.094 159.089];
theta_launch_lu17=[160.120 161.151 161.979 163.015 164.046 164.911 166.121 166.953 167.983
168.911];
theta_launch_lu18=[170.038 171.072 172.072 173.084 174.003 175.108 176.079 177.065 178.008 179.18
180.058];
theta_launch_lu=[theta_launch_lu1 theta_launch_lu2 theta_launch_lu3 theta_launch_lu4 theta_launch_lu5
theta_launch_lu6 theta_launch_lu7 theta_launch_lu8 theta_launch_lu9 theta_launch_lu10
theta_launch_lu11 theta_launch_lu12 theta_launch_lu13 theta_launch_lu14 theta_launch_lu15
theta_launch_lu16 theta_launch_lu17 theta_launch_lu18];

```

```

phi_launch_lu1=[93.12 93.12 93.12 93.12 93.12 93.12 93.12 93.12 93.12 93.12];
phi_launch_lu2=[93.12 93.12 93.12 93.12 93.12 93.12 93.12 93.12 93.12 93.12];
phi_launch_lu3=[93.12 93.12 93.12 93.12 93.12 93.12 93.12 93.12 93.12 93.12];
phi_launch_lu4=[93.12 93.12 93.12 93.12 93.12 93.12 93.12 93.12 93.12 93.12];
phi_launch_lu5=[93.12 93.12 93.12 93.12 93.12 93.12 93.12 93.12 93.12 93.12];
phi_launch_lu6=[93.12 93.12 93.12 93.12 93.12 93.12 93.12 93.12 93.12 93.12];
phi_launch_lu7=[93.12 93.12 93.12 93.12 93.12 93.12 93.12 93.12 93.12 93.12];
phi_launch_lu8=[93.12 93.12 93.12 93.12 93.12 93.12 93.12 93.12 93.12 92.92 92.92];
phi_launch_lu9=[92.917 92.916 92.915 92.914 92.913 92.911 92.910 92.909 92.908 92.906];
phi_launch_lu10=[92.905 92.904 92.903 92.919 92.918 92.917 92.916 92.914 92.913 92.912];
phi_launch_lu11=[92.910 92.909 92.908 92.906 92.905 92.903 92.902 92.900 92.899 92.897];
phi_launch_lu12=[92.895 92.893 92.891 92.890 92.888 92.886 92.884 92.882 92.879 92.877];
phi_launch_lu13=[92.875 92.873 92.871 92.868 92.866 92.864 92.861 92.859 92.856 92.854];
phi_launch_lu14=[92.851 92.849 92.846 92.843 92.841 92.838 92.835 92.833 92.830 92.828];
phi_launch_lu15=[92.825 92.822 92.820 92.817 92.815 92.812 92.890 92.807 92.805 92.802];
phi_launch_lu16=[92.800 92.798 92.795 92.793 93.065 93.050 93.068 92.878 93.041 92.861];
phi_launch_lu17=[92.839 92.834 92.898 92.825 92.866 93.056 92.863 92.866 93.015 92.887];
phi_launch_lu18=[92.818 92.859 93.006 92.875 92.853 92.846 92.943 93.017 92.865 92.834 92.870];
phi_launch_lu=[phi_launch_lu1 phi_launch_lu2 phi_launch_lu3 phi_launch_lu4 phi_launch_lu5
phi_launch_lu6 phi_launch_lu7 phi_launch_lu8 phi_launch_lu9 phi_launch_lu10 phi_launch_lu11
phi_launch_lu12 phi_launch_lu13 phi_launch_lu14 phi_launch_lu15 phi_launch_lu16 phi_launch_lu17
phi_launch_lu18];

```

```

elseif exp_type==4;
%SPEC NET
%Define properties of expendable and sphere
%Sphere
W_sphere=5.2;
CD_sphere=.15; % general sphere information
S_sphere=.196;

%Expendable
CD_exp=1.16;
S_exp=15.6;
W_exp=2.32;

%Define vectors to be used to determine expendable launch angle
%if there is a tracker on the A/C

```

```

%Define time required for expendable to get to target point on lethal sphere
time_lu1=[.1456 .1456 .1456 .1456 .1456 .1456 .1456 .1456 .1456 .1456];
time_lu2=[.1456 .1455 .1455 .1455 .1455 .1455 .1455 .1454 .1454 .1454];
time_lu3=[.1453 .1453 .1453 .1453 .1452 .1452 .1450 .1449 .1451 .1451];

```

```

time_lu4=[.1451 .1448 .1448 .1448 .1448 .1447 .1448 .1448 .1447 .1447];
time_lu5=[.1447 .1447 .1447 .1446 .1446 .1446 .1446 .1446 .1446 .1446];
time_lu6=[.1445 .1445 .1445 .1445 .1445 .1445 .1445 .1445 .1445 .1444];
time_lu7=[.1444 .1444 .1444 .1444 .1444 .1444 .1444 .1444 .1444 .1444];
time_lu8=[.1444 .1444 .1444 .1444 .1444 .1444 .1444 .1444 .1444 .1444];
time_lu9=[.1444 .1444 .1444 .1444 .1444 .1444 .1444 .1444 .1444 .1444];
time_lu10=[.1444 .1444 .1444 .1444 .1444 .1444 .1444 .1444 .1444 .1444];
time_lu11=[.1444 .1444 .1444 .1444 .1444 .1444 .1443 .1443 .1443 .1440];
time_lu12=[.1440 .1440 .1440 .1440 .1440 .1440 .1440 .1440 .1440 .1440];
time_lu13=[.1440 .1440 .1440 .1440 .1437 .1436 .1436 .1435 .1435 .1435];
time_lu14=[.1434 .1434 .1434 .1433 .1433 .1433 .1433 .1432 .1432 .1432];
time_lu15=[.1432 .1431 .1431 .1431 .1431 .1431 .1431 .1436 .1432 .1432];
time_lu16=[.1432 .1431 .1431 .1431 .1431 .1431 .1431 .1435 .1431 .1435];
time_lu17=[.1431 .1432 .1436 .1436 .1436 .1433 .1437 .1436 .1436 .1436];
time_lu18=[.1437 .1437 .1437 .1436 .1436 .1437 .1436 .1436 .1436 .1437];
time_lu=[time_lu1 time_lu2 time_lu3 time_lu4 time_lu5 time_lu6 time_lu7 time_lu8 time_lu9 time_lu10
time_lu11 time_lu12 time_lu13 time_lu14 time_lu15 time_lu16 time_lu17 time_lu18];

```

```

%Define angle at which missile is coming at aircraft. This will always be 0-180 by 1 as shown below
theta_missile_lu=[0 1 2 3 4 5 6 7 8 9 10 11 12 13 14 15 16 17 18 19 20 21 22 23 24 25 26 27 28 29 30 31
32 33 34 35 36 37 38 39 40 41 42 43 44 45 46 47 48 49 50 51 52 53 54 55 56 57 58 59 60 61 62 63 64 65
66 67 68 69 70 71 72 73 74 75 76 77 78 79 80 81 82 83 84 85 86 87 88 89 90 91 92 93 94 95 96 97 98 99
100 101 102 103 104 105 106 107 108 109 110 111 112 113 114 115 116 117 118 119 120 121 122 123
124 125 126 127 128 129 130 131 132 133 134 135 136 137 138 139 140 141 142 143 144 145 146 147
148 149 150 151 152 153 154 155 156 157 158 159 160 161 162 163 164 165 166 167 168 169 170 171
172 173 174 175 176 177 178 179 180];

```

```

%Define angle at which launcher should be aimed corresponding to the angle at which the missile is
%coming at the aircraft shown above
theta_launch_lu1=[0 1 2 3 4 5 6 7 8 9];
theta_launch_lu2=[10 11 12 13 14 15 16 17 17.798 18.8];
theta_launch_lu3=[19.794 20.788 21.783 22.779 23.775 24.771 25.768 26.765 27.799 28.798];
theta_launch_lu4=[29.798 30.797 31.797 32.798 33.798 34.800 35.762 36.764 37.766 38.769];
theta_launch_lu5=[39.772 40.775 41.778 42.782 43.786 44.790 45.795 46.799 48 49];
theta_launch_lu6=[50 51 52 53 54 55 56 57 58 59];
theta_launch_lu7=[60 61 62 63 64 65 66 67 68 69];
theta_launch_lu8=[70 71 72 73 74 75 76 77 78 79];
theta_launch_lu9=[80 81 82 83 84 85 86 87 88 89];
theta_launch_lu10=[90 91 92 93 94 95 96 97 98 99];
theta_launch_lu11=[100 101 102 103 104 105 106 107 108 109];
theta_launch_lu12=[110 111 112 112.798 113.792 114.783 115.774 116.766 117.758 118.751];
theta_launch_lu13=[119.744 120.738 121.733 122.728 123.724 124.721 125.719 126.717 127.716
128.715];
theta_launch_lu14=[129.715 130.716 131.718 132.720 133.723 134.726 135.731 136.735 137.741
138.747];
theta_launch_lu15=[139.753 140.761 141.768 142.776 143.785 144.793 146.033 147 148 149];
theta_launch_lu16=[150 151 152 153 153.967 154.953 156.028 156.882 157.917 159.031];
theta_launch_lu17=[159.989 160.968 162.155 162.946 164.002 164.926 165.960 166.973 167.977
169.092];
theta_launch_lu18=[170.201 171.202 172.237 172.981 173.995 175.016 176.216 176.979 177.938
179.217 179.988];
theta_launch_lu=[theta_launch_lu1 theta_launch_lu2 theta_launch_lu3 theta_launch_lu4 theta_launch_lu5
theta_launch_lu6 theta_launch_lu7 theta_launch_lu8 theta_launch_lu9 theta_launch_lu10
theta_launch_lu11 theta_launch_lu12 theta_launch_lu13 theta_launch_lu14 theta_launch_lu15
theta_launch_lu16 theta_launch_lu17 theta_launch_lu18];

```

```

phi_launch_lu1=[93.12 93.12 93.12 93.12 93.12 93.12 93.12 93.12 93.12 93.12];
phi_launch_lu2=[93.12 93.12 93.12 93.12 93.12 93.12 93.12 93.12 93.12 93.12];
phi_launch_lu3=[93.12 93.12 93.12 93.12 93.12 93.12 93.12 93.12 93.12 93.12];
phi_launch_lu4=[93.12 93.12 93.12 93.12 93.12 93.12 93.12 93.12 93.12 93.12];
phi_launch_lu5=[93.12 93.12 93.12 93.12 93.12 93.12 93.12 93.12 93.12 93.12];
phi_launch_lu6=[93.12 93.12 93.12 93.12 93.12 93.12 93.12 93.12 93.12 93.12];
phi_launch_lu7=[93.12 93.12 93.12 93.12 93.12 93.12 93.12 93.12 93.12 93.12];
phi_launch_lu8=[93.12 93.12 93.12 93.12 93.12 93.12 93.12 93.12 92.92 92.919];
phi_launch_lu9=[92.918 92.917 92.916 92.915 92.913 92.912 92.911 92.910 92.909 92.907];
phi_launch_lu10=[92.906 92.905 92.920 92.918 92.917 92.916 92.915 92.914 92.912 92.911];
phi_launch_lu11=[92.910 92.908 92.907 92.906 92.904 92.903 92.901 92.899 92.898 92.896];
phi_launch_lu12=[92.894 92.893 92.891 92.889 92.887 92.885 92.883 92.881 92.879 92.877];
phi_launch_lu13=[93.874 92.872 92.870 92.868 92.865 92.863 92.860 92.858 92.856 93.853];
phi_launch_lu14=[92.850 92.848 92.845 92.843 92.840 92.838 92.835 92.832 92.830 92.827];
phi_launch_lu15=[92.824 92.822 92.819 92.817 92.814 92.811 93.026 92.806 92.804 92.802];
phi_launch_lu16=[92.799 92.797 92.795 92.793 93.033 93.047 93.063 93.036 92.847 93.039];
phi_launch_lu17=[92.856 92.866 92.833 92.843 92.840 93.047 93.027 92.863 92.890 92.876];
phi_launch_lu18=[93.004 93.055 92.852 92.889 92.834 92.889 92.850 92.873 92.868 92.849 92.870];
phi_launch_lu=[phi_launch_lu1 phi_launch_lu2 phi_launch_lu3 phi_launch_lu4 phi_launch_lu5
phi_launch_lu6 phi_launch_lu7 phi_launch_lu8 phi_launch_lu9 phi_launch_lu10 phi_launch_lu11
phi_launch_lu12 phi_launch_lu13 phi_launch_lu14 phi_launch_lu15 phi_launch_lu16 phi_launch_lu17
phi_launch_lu18];

```

```

elseif exp_type==5
%DEUCE BAG

```

```

%Define properties of expendable and sphere
%Sphere

```

```

W_sphere=41;
CD_sphere=.15; % general sphere information
S_sphere=.196;

```

```

%Expendable

```

```

CD_exp=1.1;
S_exp=158.4;
W_exp=38.12;

```

```

%Define vectors to be used to determine expendable launch angle
%if there is a tracker on the A/C

```

```

%Define time required for expendable to get to target point on lethal sphere

```

```

time_lu1=[.1434 .1434 .1434 .1434 .1434 .1434 .1434 .1434 .1434 .1434];
time_lu2=[.1434 .1434 .1434 .1434 .1434 .1434 .1434 .1434 .1434 .1434];
time_lu3=[.1434 .1434 .1434 .1434 .1434 .1434 .1434 .1434 .1434 .1434];
time_lu4=[.1434 .1434 .1434 .1434 .1434 .1434 .1433 .1433 .1433 .1433];
time_lu5=[.1433 .1433 .1433 .1433 .1433 .1433 .1433 .1433 .1433 .1433];
time_lu6=[.1433 .1433 .1433 .1433 .1433 .1433 .1433 .1433 .1433 .1433];;
time_lu7=[.1433 .1433 .1433 .1433 .1433 .1433 .1433 .1433 .1432 .1432];
time_lu8=[.1432 .1432 .1432 .1432 .1432 .1432 .1432 .1432 .1432 .1432];
time_lu9=[.1432 .1432 .1432 .1432 .1432 .1432 .1432 .1432 .1431 .1431];
time_lu10=[.1431 .1431 .1431 .1431 .1431 .1431 .1431 .1431 .1431 .1431];
time_lu11=[.1431 .1431 .1431 .1431 .1431 .1431 .1430 .1430 .1430 .1430];

```

```

time_lu12=[.1430 .1430 .1430 .1430 .1430 .1430 .1429 .1429 .1429 .1429];
time_lu13=[.1429 .1429 .1427 .1427 .1430 .1426 .1426 .1426 .1426 .1431];
time_lu14=[.1430 .1431 .1430 .1432 .1429 .1428 .1428 .1430 .1426 .1426];
time_lu15=[.1426 .1426 .1426 .1430 .1430 .1429 .1431 .1432 .1427 .1427];
time_lu16=[.1431 .1430 .1431 .1431 .1431 .1431 .1430 .1431 .1426 .1426];
time_lu17=[.1431 .143 .1432 .1428 .1431 .1426 .1426 .1426 .1427 .1426];
time_lu18=[.1426 .1426 .1427 .1427 .1427 .1427 .1427 .1426 .1427 .1426];
time_lu=[time_lu1 time_lu2 time_lu3 time_lu4 time_lu5 time_lu6 time_lu7 time_lu8 time_lu9 time_lu10
time_lu11 time_lu12 time_lu13 time_lu14 time_lu15 time_lu16 time_lu17 time_lu18];

```

```

%Define angle at which missile is coming at aircraft. This will always be 0-180 by 1 as shown below
theta_missile_lu=[0 1 2 3 4 5 6 7 8 9 10 11 12 13 14 15 16 17 18 19 20 21 22 23 24 25 26 27 28 29 30 31
32 33 34 35 36 37 38 39 40 41 42 43 44 45 46 47 48 49 50 51 52 53 54 55 56 57 58 59 60 61 62 63 64 65
66 67 68 69 70 71 72 73 74 75 76 77 78 79 80 81 82 83 84 85 86 87 88 89 90 91 92 93 94 95 96 97 98 99
100 101 102 103 104 105 106 107 108 109 110 111 112 113 114 115 116 117 118 119 120 121 122 123
124 125 126 127 128 129 130 131 132 133 134 135 136 137 138 139 140 141 142 143 144 145 146 147
148 149 150 151 152 153 154 155 156 157 158 159 160 161 162 163 164 165 166 167 168 169 170 171
172 173 174 175 176 177 178 179 180];

```

```

%Define angle at which launcher should be aimed corresponding to the angle at which the missile is
%coming at the aircraft shown above
theta_launch_lu1=[0 1 2 3 4 5 6 7 8 9];
theta_launch_lu2=[10 11 12 13 14 15 16 17 18 19];
theta_launch_lu3=[20 21 22 23 24 25 26 27 28 29];
theta_launch_lu4=[30 31 32 33 34 35 36 37 38 39];
theta_launch_lu5=[40 41 42 43 44 45 46 47 48 49];
theta_launch_lu6=[50 51 52 53 54 55 56 57 58 59];
theta_launch_lu7=[60 61 62 63 64 65 66 67 68 69];
theta_launch_lu8=[70 71 72 73 74 75 76 77 78 79];
theta_launch_lu9=[80 81 82 83 84 85 86 87 88 89];
theta_launch_lu10=[90 91 92 93 94 95 96 97 98 99];
theta_launch_lu11=[100 101 102 103 104 105 106 107 108 109];
theta_launch_lu12=[110 111 112 113 114 115 116 117 118 119];
theta_launch_lu13=[120 121 122.03 122.962 123.986 124.951 125.903 126.887 128.153 129.088];
theta_launch_lu14=[130.057 131.138 132.027 133.168 133.917 134.948 135.912 136.969 138 139];
theta_launch_lu15=[140 141 142 143 144 144.935 146.1 147.148 147.892 148.949];
theta_launch_lu16=[150.132 151.063 152.094 153.01 154.004 154.935 155.901 156.945 157.908
158.883];
theta_launch_lu17=[159.977 161.002 161.937 163.163 164.022 164.957 165.953 167.012 168.084
168.965];
theta_launch_lu18=[170.005 170.983 171.916 173.027 174.103 175.117 176.1 176.948 177.937 178.938
180.073];
theta_launch_lu=[theta_launch_lu1 theta_launch_lu2 theta_launch_lu3 theta_launch_lu4 theta_launch_lu5
theta_launch_lu6 theta_launch_lu7 theta_launch_lu8 theta_launch_lu9 theta_launch_lu10
theta_launch_lu11 theta_launch_lu12 theta_launch_lu13 theta_launch_lu14 theta_launch_lu15
theta_launch_lu16 theta_launch_lu17 theta_launch_lu18];

```

```

phi_launch_lu1=[93.12 93.12 93.12 93.12 93.12 93.12 93.12 93.12 93.12 93.12 93.12 93.12];
phi_launch_lu2=[93.12 93.12 93.12 93.12 93.12 93.12 93.12 93.12 93.12 93.12 93.12 93.12];
phi_launch_lu3=[93.12 93.12 93.12 93.12 93.12 93.12 93.12 93.12 93.12 93.12 93.12 93.12];
phi_launch_lu4=[93.12 93.12 93.12 93.12 93.12 93.12 93.12 93.12 93.12 93.12 93.12 93.12];
phi_launch_lu5=[93.12 93.12 93.12 93.12 93.12 93.12 93.12 93.12 93.12 93.12 93.12 93.12];
phi_launch_lu6=[93.12 93.12 93.12 93.12 93.12 93.12 93.12 93.12 93.12 93.12 93.12 93.12];
phi_launch_lu7=[93.12 93.12 93.12 93.12 93.12 93.12 93.12 93.12 93.12 93.12 93.12 93.12];

```

```

phi_launch_lu8=[93.12 93.12 93.12 93.12 93.12 93.12 93.12 93.12 93.92 92.918 92.917];
phi_launch_lu9=[92.916 92.915 92.914 92.913 92.912 92.910 92.909 92.908 92.907 92.906];
phi_launch_lu10=[92.904 92.903 92.902 92.901 92.899 92.898 92.897 92.895 92.894 92.892];
phi_launch_lu11=[92.891 92.889 92.888 92.886 92.885 92.883 92.881 92.88 92.878 92.876];
phi_launch_lu12=[92.874 92.873 92.871 92.869 92.867 92.865 92.863 92.861 92.859 92.857];
phi_launch_lu13=[93.855 92.853 92.895 92.910 92.020 92.934 92.889 92.934 92.913 93.104];
phi_launch_lu14=[92.834 92.920 93.017 93.070 93.015 92.904 93.024 93.096 92.815 92.812];
phi_launch_lu15=[92.810 92.807 92.805 92.802 92.800 93.014 92.877 93.065 92.876 92.908];
phi_launch_lu16=[92.886 92.906 92.856 93.049 93.011 93.032 92.824 93.083 92.843 92.867];
phi_launch_lu17=[92.902 92.895 93.036 93.040 92.889 92.869 92.868 92.821 92.866 92.849];
phi_launch_lu18=[92.860 92.856 92.864 92.891 92.836 92.857 92.838 92.851 92.953 92.955 92.828];
phi_launch_lu=[phi_launch_lu1 phi_launch_lu2 phi_launch_lu3 phi_launch_lu4 phi_launch_lu5
phi_launch_lu6 phi_launch_lu7 phi_launch_lu8 phi_launch_lu9 phi_launch_lu10 phi_launch_lu11
phi_launch_lu12 phi_launch_lu13 phi_launch_lu14 phi_launch_lu15 phi_launch_lu16 phi_launch_lu17
phi_launch_lu18];
elseif exp_type==6 %CHERRY BOMB iteration 3

```

```

%Define properties of expendable and sphere

```

```

%Sphere

```

```

W_sphere=78.26; %weight of the capsule holding the expendable
CD_sphere=.22; % general sphere information
S_sphere=.1418;

```

```

%Expendable

```

```

CD_exp=.38;
S_exp=1.04e-4;
W_exp=1.65e-5;

```

```

%Define vectors to be used to determine expendable launch angle

```

```

%if there is a tracker on the A/C

```

```

%Define time required for expendable to get to target point on lethal sphere

```

```

time_lu(1:10)=[.1433 .1433 .1433 .1433 .1433 .1433 .1433 .1433 .1433 .1433];
time_lu(11:20)=[.1433 .1433 .1433 .1433 .1433 .1433 .1433 .1433 .1433 .1433];
time_lu(21:30)=[.1433 .1433 .1433 .1433 .1433 .1433 .1433 .1433 .1433 .1433];
time_lu(31:40)=[.1433 .1433 .1433 .1433 .1433 .1433 .1433 .1433 .1433 .1433];
time_lu(41:50)=[.1433 .1432 .1432 .1432 .1432 .1432 .1432 .1432 .1432 .1432];
time_lu(51:60)=[.1432 .1432 .1432 .1432 .1432 .1432 .1432 .1432 .1432 .1432];
time_lu(61:70)=[.1432 .1432 .1432 .1432 .1432 .1432 .1432 .1432 .1432 .1432];
time_lu(71:80)=[.1432 .1432 .1432 .1432 .1432 .1432 .1432 .1431 .1431 .1431];
time_lu(81:90)=[.1431 .1431 .1431 .1431 .1431 .1431 .1431 .1431 .1431 .1431];
time_lu(91:100)=[.1431 .1431 .1431 .1431 .1431 .1431 .1431 .1431 .1431 .1431];
time_lu(101:110)=[.1431 .1431 .1431 .1431 .1430 .1430 .1430 .1430 .1430 .1430];
time_lu(111:120)=[.1430 .1430 .1430 .1430 .1430 .1427 .1428 .1429 .1428 .1428];
time_lu(121:130)=[.1431 .1429 .1428 .1430 .1431 .1428 .1431 .1427 .1431 .1431];
time_lu(131:140)=[.1427 .1428 .1431 .1426 .1431 .1426 .1428 .1426 .1426 .1427];
time_lu(141:150)=[.1427 .1427 .1427 .1427 .1427 .1432 .1431 .1430 .1431 .1430];
time_lu(151:160)=[.1431 .1431 .1431 .1427 .1431 .1431 .1427 .1431 .1427 .1432];
time_lu(161:170)=[.1432 .1432 .1428 .1427 .1428 .1432 .1427 .1427 .1432 .14232];
time_lu(171:181)=[.1432 .1427 .1427 .1427 .1427 .1427 .1427 .1427 .1427 .1427];

```

```

%Define angle at which missile is coming at aircraft. This will always be 0-180 by 1 as shown below

```

```

theta_missile_lu=[0 1 2 3 4 5 6 7 8 9 10 11 12 13 14 15 16 17 18 19 20 21 22 23 24 25 26 27 28 29 30 31
32 33 34 35 36 37 38 39 40 41 42 43 44 45 46 47 48 49 50 51 52 53 54 55 56 57 58 59 60 61 62 63 64 65

```

```
66 67 68 69 70 71 72 73 74 75 76 77 78 79 80 81 82 83 84 85 86 87 88 89 90 91 92 93 94 95 96 97 98 99
100 101 102 103 104 105 106 107 108 109 110 111 112 113 114 115 116 117 118 119 120 121 122 123
124 125 126 127 128 129 130 131 132 133 134 135 136 137 138 139 140 141 142 143 144 145 146 147
148 149 150 151 152 153 154 155 156 157 158 159 160 161 162 163 164 165 166 167 168 169 170 171
172 173 174 175 176 177 178 179 180];
```

```
%Define angle at which launcher should be aimed corresponding to the angle at which the missile is
%coming at the aircraft shown above
```

```
theta_launch_lu(1:10)=[0 1 2 3 4 5 6 7 8 9];
theta_launch_lu(11:20)=[10 11 12 13 14 15 16 17 18 19];
theta_launch_lu(21:30)=[20 21 22 23 24 25 26 27 28 29];
theta_launch_lu(31:40)=[30 31 32 33 34 35 36 37 38 39];
theta_launch_lu(41:50)=[40 41 42 43 44 45 46 47 48 49];
theta_launch_lu(51:60)=[50 51 52 53 54 55 56 57 58 59];
theta_launch_lu(61:70)=[60 61 62 63 64 65 66 67 68 69];
theta_launch_lu(71:80)=[70 71 72 73 74 75 76 77 78 79];
theta_launch_lu(81:90)=[80 81 82 83 84 85 86 87 88 89];
theta_launch_lu(91:100)=[90 91 92 93 94 95 96 97 98 99];
theta_launch_lu(101:110)=[100 101 102 103 104 105 106 107 108 109];
theta_launch_lu(111:120)=[110 111 111.987 112.785 113.962 115.003 115.798 116.887 117.793
118.889];
theta_launch_lu(121:130)=[120.044 120.963 121.986 122.991 124.010 124.924 126.076 126.875 128.012
129.060];
theta_launch_lu(131:140)=[129.931 130.938 132.106 132.878 134.158 134.913 135.915 136.930 137.916
138.876];
theta_launch_lu(141:150)=[139.843 140.900 141.856 142.899 143.849 145.100 146.121 146.960 148.071
148.895];
theta_launch_lu(151:160)=[150.026 151.076 151.927 152.934 153.980 154.969 155.928 156.965 157.884
159.001];
theta_launch_lu(161:170)=[160.012 161.013 162.024 163.084 164.068 165.165 165.946 167.078 168.134
169.180];
theta_launch_lu(171:181)=[170.145 171.096 172.103 173.156 174.175 175.161 175.947 177.164 178.272
179.232 179.967];
```

```
phi_launch_lu(1:10)=[93.12 93.12 93.12 93.12 93.12 93.12 93.12 93.12 93.12 93.12];
phi_launch_lu(11:20)=[93.12 93.12 93.12 93.12 93.12 93.12 93.12 93.12 93.12 93.12];
phi_launch_lu(21:30)=[93.12 93.12 93.12 93.12 93.12 93.12 93.12 93.12 93.12 93.12];
phi_launch_lu(31:40)=[93.12 93.12 93.12 93.12 93.12 93.12 93.12 93.12 93.12 93.12];
phi_launch_lu(41:50)=[93.12 93.12 93.12 93.12 93.12 93.12 93.12 93.12 93.12 93.12];
phi_launch_lu(51:60)=[93.12 93.12 93.12 93.12 93.12 93.12 93.12 93.12 93.12 93.12];
phi_launch_lu(61:70)=[93.12 93.12 93.12 93.12 93.12 93.12 93.12 93.12 93.12 93.12];
phi_launch_lu(71:80)=[93.12 93.12 93.12 93.12 93.12 93.12 93.12 93.12 93.12 93.12];
phi_launch_lu(81:90)=[93.12 93.12 93.12 93.12 93.12 93.12 93.12 93.12 93.12 93.12];
phi_launch_lu(91:100)=[93.12 93.12 93.12 93.12 93.12 93.12 93.12 93.12 93.12 93.12];
phi_launch_lu(101:110)=[93.12 93.12 93.12 93.12 93.12 93.12 93.12 93.12 93.12 93.12];
phi_launch_lu(111:120)=[93.12 93.12 93.25 93.461 93.488 93.428 93.443 93.245 93.274 93.245];
phi_launch_lu(121:130)=[93.239 93.435 93.190 93.321 93.434 93.248 93.229 93.234 93.197 93.368];
phi_launch_lu(131:140)=[93.356 93.230 93.268 93.422 93.353 93.361 93.417 93.241 93.357 93.228];
phi_launch_lu(141:150)=[93.263 93.390 93.223 93.246 93.196 93.218 93.386 93.374 93.441 93.227];
phi_launch_lu(151:160)=[93.185 93.407 93.219 93.265 93.390 93.247 93.196 93.229 93.404 93.424];
phi_launch_lu(161:170)=[93.400 93.404 93.425 93.226 93.226 93.420 93.384 93.445 93.251 93.228];
phi_launch_lu(171:181)=[93.410 93.217 93.261 93.206 93.200 93.237 93.246 93.246 93.247 93.222
93.244];
```

```
elseif exp_type==7 %DET NET iteration 3
```



```

%Define properties of expendable and sphere
  %Sphere
    W_sphere=12.08; %weight of the capsule holding the expendable
    CD_sphere=.22; % general sphere information
    S_sphere=.1418;

  %Expendable
    CD_exp=1.16;
    S_exp=23.21;
    W_exp=7.3;

%Define vectors to be used to determine expendable launch angle
%if there is a tracker on the A/C

```

```

%Define time required for expendable to get to target point on lethal sphere
time_lu(1:10)=[.144 .144 .144 .144 .144 .144 .144 .144 .144 .144];
time_lu(11:20)=[.144 .144 .144 .144 .144 .144 .144 .144 .144 .144];
time_lu(21:30)=[.144 .144 .144 .144 .144 .144 .144 .144 .144 .144];
time_lu(31:40)=[.144 .144 .144 .144 .144 .144 .144 .144 .144 .1438];
time_lu(41:50)=[.1438 .1437 .1437 .1437 .1437 .1437 .1437 .1437 .1437 .1436];
time_lu(51:60)=[.1436 .1436 .1436 .1436 .1436 .1436 .1436 .1436 .1436 .1436];
time_lu(61:70)=[.1436 .1436 .1436 .1436 .1435 .1435 .1435 .1435 .1435 .1435];
time_lu(71:80)=[.1435 .1435 .1435 .1435 .1436 .1436 .1436 .1436 .1436 .1436];
time_lu(81:90)=[.1436 .1436 .1436 .1436 .1436 .1436 .1436 .1436 .1436 .1436];
time_lu(91:100)=[.1436 .1436 .1436 .1436 .1436 .1436 .1436 .1436 .1436 .1436];
time_lu(101:110)=[.1436 .1436 .1436 .1436 .1436 .1436 .1436 .1436 .1436 .1436];
time_lu(111:120)=[.1436 .1436 .1435 .1435 .1435 .1433 .1433 .1432 .1433 .1433];
time_lu(121:130)=[.1434 .1433 .1431 .1434 .1431 .1432 .1431 .1433 .1431 .1433];
time_lu(131:140)=[.1434 .1434 .1429 .1429 .143 .1433 .1429 .143 .1433 .1429];
time_lu(141:150)=[.1429 .1429 .1429 .1429 .1431 .1431 .1431 .1431 .1432 .1431];
time_lu(151:160)=[.1432 .1432 .1433 .1433 .1433 .1432 .1433 .1433 .1433 .1433];
time_lu(161:170)=[.1433 .1433 .1433 .1434 .1434 .1434 .1434 .1428 .1433 .1428];
time_lu(171:181)=[.143 .1429 .1429 .143 .143 .1429 .1429 .1429 .1429 .1429];

```

```

%Define angle at which missile is coming at aircraft. This will always be 0-180 by 1 as shown below
theta_missile_lu=[0 1 2 3 4 5 6 7 8 9 10 11 12 13 14 15 16 17 18 19 20 21 22 23 24 25 26 27 28 29 30 31
32 33 34 35 36 37 38 39 40 41 42 43 44 45 46 47 48 49 50 51 52 53 54 55 56 57 58 59 60 61 62 63 64 65
66 67 68 69 70 71 72 73 74 75 76 77 78 79 80 81 82 83 84 85 86 87 88 89 90 91 92 93 94 95 96 97 98 99
100 101 102 103 104 105 106 107 108 109 110 111 112 113 114 115 116 117 118 119 120 121 122 123
124 125 126 127 128 129 130 131 132 133 134 135 136 137 138 139 140 141 142 143 144 145 146 147
148 149 150 151 152 153 154 155 156 157 158 159 160 161 162 163 164 165 166 167 168 169 170 171
172 173 174 175 176 177 178 179 180];

```

```

%Define angle at which launcher should be aimed corresponding to the angle at which the missile is
%coming at the aircraft shown above
theta_launch_lu(1:10)=[0 1 2 3 4 5 6 7 8 9];
theta_launch_lu(11:20)=[10 11 12 13 14 15 16 17 18 19];
theta_launch_lu(21:30)=[20 21 22 23 24 25 26 27 28 29];
theta_launch_lu(31:40)=[30 31 32 33 34 35 36 37 38 39];
theta_launch_lu(41:50)=[40 41 42 43 44 45 46 47 48 49];
theta_launch_lu(51:60)=[50 51 52 53 54 55 56 57 58 59];
theta_launch_lu(61:70)=[60 61 62 63 64 65 66 67 68 69];
theta_launch_lu(71:80)=[70 71 72 73 74 75 76 77 78 79];
theta_launch_lu(81:90)=[80 81 82 83 84 85 86 87 88 89];

```

```

theta_launch_lu(91:100)=[90 91 92 93 94 95 96 97 98 99];
theta_launch_lu(101:110)=[100 101 102 103 104 105 106 107 108 109];
theta_launch_lu(111:120)=[110 111 112 113 114 114.795 116.015 116.971 117.745 118.849];
theta_launch_lu(121:130)=[119.908 120.814 121.706 122.890 123.763 124.856 125.725 126.967 127.893
128.888];
theta_launch_lu(131:140)=[130.046 131.011 131.815 132.821 133.905 135.054 135.880 136.875 138.073
138.951];
theta_launch_lu(141:150)=[139.830 140.884 141.872 142.831 143.912 144.876 145.866 146.917 147.984
148.866];
theta_launch_lu(151:160)=[149.953 151.120 152.115 153.072 154.124 154.913 156.053 156.984 158.069
159.098];
theta_launch_lu(161:170)=[160.164 161.121 162.010 163.091 164.075 165.150 166.183 166.938 168.189
168.940];
theta_launch_lu(171:181)=[170.194 171.025 171.995 173.157 174.158 175.160 176.199 176.971 178.241
179.038 180.017];

```

```

%Define phi angle at which launcher should be aimed in order to hit missile.

```

```

phi_launch_lu(1:10)=[93.12 93.12 93.12 93.12 93.12 93.12 93.12 93.12 93.12 93.12];
phi_launch_lu(11:20)=[93.12 93.12 93.12 93.12 93.12 93.12 93.12 93.12 93.12 93.12];
phi_launch_lu(21:30)=[93.12 93.12 93.12 93.12 93.12 93.12 93.12 93.12 93.12 93.12];
phi_launch_lu(31:40)=[93.12 93.12 93.12 93.12 93.12 93.12 93.12 93.12 93.12 93.12];
phi_launch_lu(41:50)=[93.12 93.12 93.12 93.12 93.12 93.12 93.12 93.12 93.12 93.12];
phi_launch_lu(51:60)=[93.12 93.12 93.12 93.12 93.12 93.12 93.12 93.12 93.12 93.12];
phi_launch_lu(61:70)=[93.12 93.12 93.12 93.12 93.12 93.12 93.12 93.12 93.12 93.12];
phi_launch_lu(71:80)=[93.12 93.12 93.12 93.12 93.12 93.12 93.12 93.12 93.12 93.12];
phi_launch_lu(81:90)=[93.12 93.12 93.12 93.12 93.12 93.12 93.12 93.12 93.12 93.12];
phi_launch_lu(91:100)=[93.12 93.12 93.12 93.12 93.12 93.12 93.12 93.12 93.12 93.12];
phi_launch_lu(101:110)=[93.12 93.12 93.12 93.12 93.12 93.12 93.12 93.12 93.12 93.12];
phi_launch_lu(111:120)=[93.12 93.12 93.12 93.12 93.12 93.12 93.12 93.12 93.229 93.139 93.271 93.45];
phi_launch_lu(121:130)=[93.365 93.358 93.423 93.306 93.194 93.366 93.442 93.407 93.197 93.181];
phi_launch_lu(131:140)=[93.254 93.354 93.373 93.260 93.148 93.423 93.359 93.224 93.171 93.266];
phi_launch_lu(141:150)=[93.402 93.232 93.229 93.212 93.390 93.368 93.382 93.411 93.198 93.206];
phi_launch_lu(151:160)=[93.255 93.203 93.419 93.451 93.232 93.378 93.410 93.379 93.210 93.236];
phi_launch_lu(161:170)=[93.416 93.424 93.391 93.227 93.231 93.430 93.393 93.387 93.213 93.427];
phi_launch_lu(171:181)=[93.256 93.450 93.233 93.245 93.247 93.244 93.415 93.234 93.233 93.252
93.402];

```

```

elseif exp_type==8 %SpecNet iteration 3

```

```

%Define properties of expendable and sphere

```

```

%Sphere

```

```

W_sphere=16.18; %weight of the capsule holding the expendable
CD_sphere=.22; % general sphere information
S_sphere=.1418;

```

```

%Expendable

```

```

CD_exp=1.16;
S_exp=37.68;
W_exp=11.47;

```

```

%Define vectors to be used to determine expendable launch angle

```

```

%if there is a tracker on the A/C

```

```

%Define time required for expendable to get to target point on lethal sphere

```

```

time_lu(1:10)=[.1440 .1440 .1440 .1440 .1440 .1440 .1440 .1440 .1440 .1440];

```

```

time_lu(11:20)=[.1440 .1440 .1440 .1440 .1440 .1440 .1440 .1440 .1440 .1440];
time_lu(21:30)=[.1440 .1440 .1440 .1440 .1438 .1438 .1438 .1437 .1437 .1437];
time_lu(31:40)=[.1437 .1437 .1437 .1437 .1437 .1437 .1436 .1436 .1436 .1436];
time_lu(41:50)=[.1436 .1436 .1436 .1436 .1436 .1436 .1435 .1435 .1435 .1435];
time_lu(51:60)=[.1435 .1435 .1435 .1435 .1435 .1435 .1435 .1435 .1435 .1435];
time_lu(61:70)=[.1435 .1434 .1434 .1434 .1434 .1434 .1434 .1434 .1434 .1434];
time_lu(71:80)=[.1434 .1434 .1434 .1434 .1434 .1434 .1434 .1434 .1434 .1434];
time_lu(81:90)=[.1434 .1434 .1434 .1434 .1434 .1435 .1435 .1435 .1435 .1435];
time_lu(91:100)=[.1435 .1435 .1435 .1435 .1435 .1435 .1435 .1435 .1435 .1435];
time_lu(101:110)=[.1435 .1435 .1434 .1434 .1434 .1434 .1434 .1434 .1434 .1434];
time_lu(111:120)=[.1434 .1434 .1434 .1434 .1434 .1431 .1431 .1431 .1431 .1430];
time_lu(121:130)=[.1431 .1430 .1431 .1431 .1431 .1431 .1433 .1430 .1433 .1429];
time_lu(131:140)=[.1433 .1429 .1428 .1428 .1428 .1428 .1433 .1429 .1429 .1433];
time_lu(141:150)=[.1427 .1428 .1433 .1428 .1431 .1432 .1431 .1431 .1431 .1431];
time_lu(151:160)=[.1432 .1432 .1432 .1432 .1432 .1428 .1432 .1432 .1433 .1433];
time_lu(161:170)=[.1433 .1428 .1433 .1433 .1433 .1433 .1433 .1429 .1428 .1429];
time_lu(171:181)=[.1429 .1428 .1429 .1428 .1429 .1429 .1429 .1429 .1428 .1429];

```

```

%Define angle at which missile is coming at aircraft. This will always be 0-180 by 1 as shown below
theta_missile_lu=[0 1 2 3 4 5 6 7 8 9 10 11 12 13 14 15 16 17 18 19 20 21 22 23 24 25 26 27 28 29 30 31
32 33 34 35 36 37 38 39 40 41 42 43 44 45 46 47 48 49 50 51 52 53 54 55 56 57 58 59 60 61 62 63 64 65
66 67 68 69 70 71 72 73 74 75 76 77 78 79 80 81 82 83 84 85 86 87 88 89 90 91 92 93 94 95 96 97 98 99
100 101 102 103 104 105 106 107 108 109 110 111 112 113 114 115 116 117 118 119 120 121 122 123
124 125 126 127 128 129 130 131 132 133 134 135 136 137 138 139 140 141 142 143 144 145 146 147
148 149 150 151 152 153 154 155 156 157 158 159 160 161 162 163 164 165 166 167 168 169 170 171
172 173 174 175 176 177 178 179 180];

```

```

%Define angle at which launcher should be aimed corresponding to the angle at which the missile is
%coming at the aircraft shown above
theta_launch_lu=[0 1 2 3 4 5 6 7 8 9 10 11 12 13 14 15 16 17 18 19 20 21 22 23 24 25 26 27 28 29 30 31
32 33 34 35 36 37 38 39 40 41 42 43 44 45 46 47 48 49 50 51 52 53 54 55 56 57 58 59 60 61 62 63 64 65
66 67 68 69 70 71 72 73 74 75 76 77 78 79 80 81 82 83 84 85 86 87 88 89 90 91 92 93 94 95 96 97 98 99
100 101 102 103 104 105 106 107 108 109 110 111 112 113 114 114.872 115.947 116.748 117.833
118.929 119.768 120.787 121.827 122.816 123.903 124.857 125.899 126.929 128.024 128.814 130.003
130.833 131.831 132.846 133.891 134.903 136.031 136.987 137.874 139.097 139.845 140.88 142.072
142.823 143.938 144.995 145.87 146.946 147.933 148.962 150.112 151.077 152.12 153.122 154.15
154.881 155.897 157.025 158.137 159.042 160.018 160.945 162.225 163.013 164.088 165.229 166.104
167.131 167.98 169.079 170.093 170.915 172.19 172.971 174.198 175.198 176.266 177.232 178.023
179.186 180.049];

```

```

phi_launch_lu(1:10)=[93.12 93.12 93.12 93.12 93.12 93.12 93.12 93.12 93.12 93.12];
phi_launch_lu(11:20)=[93.12 93.12 93.12 93.12 93.12 93.12 93.12 93.12 93.12 93.12];
phi_launch_lu(21:30)=[93.12 93.12 93.12 93.12 93.12 93.12 93.12 93.12 93.12 93.12];
phi_launch_lu(31:40)=[93.12 93.12 93.12 93.12 93.12 93.12 93.12 93.12 93.12 93.12];
phi_launch_lu(41:50)=[93.12 93.12 93.12 93.12 93.12 93.12 93.12 93.12 93.12 93.12];
phi_launch_lu(51:60)=[93.12 93.12 93.12 93.12 93.12 93.12 93.12 93.12 93.12 93.12];
phi_launch_lu(61:70)=[93.12 93.12 93.12 93.12 93.12 93.12 93.12 93.12 93.12 93.12];
phi_launch_lu(71:80)=[93.12 93.12 93.12 93.12 93.12 93.12 93.12 93.12 93.12 93.12];
phi_launch_lu(81:90)=[93.12 93.12 93.12 93.12 93.12 93.12 93.12 93.12 93.12 93.12];
phi_launch_lu(91:100)=[93.12 93.12 93.12 93.12 93.12 93.12 93.12 93.12 93.12 93.12];
phi_launch_lu(101:110)=[93.12 93.12 93.12 93.12 93.12 93.12 93.12 93.12 93.12 93.12];
phi_launch_lu(111:120)=[93.12 93.12 93.12 93.12 93.12 93.472 93.398 93.273 93.373 93.236];
phi_launch_lu(121:130)=[93.351 93.175 93.441 93.268 93.260 93.427 93.192 93.369 93.187 93.248];
phi_launch_lu(131:140)=[93.431 93.170 93.372 93.420 93.392 93.219 93.228 93.247 93.392 93.200];
phi_launch_lu(141:150)=[93.436 93.230 93.393 93.216 93.457 93.219 93.420 93.187 93.429 93.424];

```

```

phi_launch_lu(151:160)=[93.393 93.243 93.203 93.216 93.198 93.386 93.397 93.381 93.211 93.237];
phi_launch_lu(161:170)=[93.409 93.230 93.200 93.458 93.446 93.428 93.242 93.410 93.252 93.256];
phi_launch_lu(171:181)=[93.441 93.260 93.237 93.255 93.238 93.236 93.242 93.215 93.237 93.426
93.215];
elseif exp_type==9 %DET NET enlarged

```

```

%Define properties of expendable and sphere

```

```

%Sphere

```

```

W_sphere=12.08; %weight of the capsule holding the expendable
CD_sphere=.22; % general sphere information
S_sphere=.1418;

```

```

%Expendable

```

```

CD_exp=1.16;
S_exp=23.21;
W_exp=15;

```

```

%Define vectors to be used to determine expendable launch angle
%if there is a tracker on the A/C

```

```

%Define time required for expendable to get to target point on lethal sphere

```

```

time_lu(1:10)=[.144 .144 .144 .144 .144 .144 .144 .144 .144 .144];
time_lu(11:20)=[.144 .144 .144 .144 .144 .144 .144 .144 .144 .144];
time_lu(21:30)=[.144 .144 .144 .144 .144 .144 .144 .144 .144 .144];
time_lu(31:40)=[.144 .144 .144 .144 .144 .144 .144 .144 .144 .1438];
time_lu(41:50)=[.1438 .1437 .1437 .1437 .1437 .1437 .1437 .1437 .1437 .1436];
time_lu(51:60)=[.1436 .1436 .1436 .1436 .1436 .1436 .1436 .1436 .1436 .1436];
time_lu(61:70)=[.1436 .1436 .1436 .1436 .1435 .1435 .1435 .1435 .1435 .1435];
time_lu(71:80)=[.1435 .1435 .1435 .1435 .1436 .1436 .1436 .1436 .1436 .1436];
time_lu(81:90)=[.1436 .1436 .1436 .1436 .1436 .1436 .1436 .1436 .1436 .1436];
time_lu(91:100)=[.1436 .1436 .1436 .1436 .1436 .1436 .1436 .1436 .1436 .1436];
time_lu(101:110)=[.1436 .1436 .1436 .1436 .1436 .1436 .1436 .1436 .1436 .1436];
time_lu(111:120)=[.1436 .1436 .1435 .1435 .1435 .1433 .1433 .1432 .1433 .1433];
time_lu(121:130)=[.1434 .1433 .1431 .1434 .1431 .1432 .1431 .1433 .1431 .1433];
time_lu(131:140)=[.1434 .1434 .1429 .1429 .143 .1433 .1429 .143 .1433 .1429];
time_lu(141:150)=[.1429 .1429 .1429 .1429 .1431 .1431 .1431 .1431 .1432 .1431];
time_lu(151:160)=[.1432 .1432 .1433 .1433 .1433 .1432 .1433 .1433 .1433 .1433];
time_lu(161:170)=[.1433 .1433 .1433 .1434 .1434 .1434 .1434 .1428 .1433 .1428];
time_lu(171:181)=[.143 .1429 .1429 .143 .143 .1429 .1429 .1429 .1429 .1429];

```

```

%Define angle at which missile is coming at aircraft. This will always be 0-180 by 1 as shown below

```

```

theta_missile_lu=[0 1 2 3 4 5 6 7 8 9 10 11 12 13 14 15 16 17 18 19 20 21 22 23 24 25 26 27 28 29 30 31
32 33 34 35 36 37 38 39 40 41 42 43 44 45 46 47 48 49 50 51 52 53 54 55 56 57 58 59 60 61 62 63 64 65
66 67 68 69 70 71 72 73 74 75 76 77 78 79 80 81 82 83 84 85 86 87 88 89 90 91 92 93 94 95 96 97 98 99
100 101 102 103 104 105 106 107 108 109 110 111 112 113 114 115 116 117 118 119 120 121 122 123
124 125 126 127 128 129 130 131 132 133 134 135 136 137 138 139 140 141 142 143 144 145 146 147
148 149 150 151 152 153 154 155 156 157 158 159 160 161 162 163 164 165 166 167 168 169 170 171
172 173 174 175 176 177 178 179 180];

```

```

%Define angle at which launcher should be aimed corresponding to the angle at which the missile is
%coming at the aircraft shown above

```

```

theta_launch_lu(1:10)=[0 1 2 3 4 5 6 7 8 9];
theta_launch_lu(11:20)=[10 11 12 13 14 15 16 17 18 19];
theta_launch_lu(21:30)=[20 21 22 23 24 25 26 27 28 29];
theta_launch_lu(31:40)=[30 31 32 33 34 35 36 37 38 39];

```

```

theta_launch_lu(41:50)=[40 41 42 43 44 45 46 47 48 49];
theta_launch_lu(51:60)=[50 51 52 53 54 55 56 57 58 59];
theta_launch_lu(61:70)=[60 61 62 63 64 65 66 67 68 69];
theta_launch_lu(71:80)=[70 71 72 73 74 75 76 77 78 79];
theta_launch_lu(81:90)=[80 81 82 83 84 85 86 87 88 89];
theta_launch_lu(91:100)=[90 91 92 93 94 95 96 97 98 99];
theta_launch_lu(101:110)=[100 101 102 103 104 105 106 107 108 109];
theta_launch_lu(111:120)=[110 111 112 113 114 114.795 116.015 116.971 117.745 118.849];
theta_launch_lu(121:130)=[119.908 120.814 121.706 122.890 123.763 124.856 125.725 126.967 127.893
128.888];
theta_launch_lu(131:140)=[130.046 131.011 131.815 132.821 133.905 135.054 135.880 136.875 138.073
138.951];
theta_launch_lu(141:150)=[139.830 140.884 141.872 142.831 143.912 144.876 145.866 146.917 147.984
148.866];
theta_launch_lu(151:160)=[149.953 151.120 152.115 153.072 154.124 154.913 156.053 156.984 158.069
159.098];
theta_launch_lu(161:170)=[160.164 161.121 162.010 163.091 164.075 165.150 166.183 166.938 168.189
168.940];
theta_launch_lu(171:181)=[170.194 171.025 171.995 173.157 174.158 175.160 176.199 176.971 178.241
179.038 180.017];

```

```

%Define phi angle at which launcher should be aimed in order to hit missile.

```

```

phi_launch_lu(1:10)=[93.12 93.12 93.12 93.12 93.12 93.12 93.12 93.12 93.12 93.12];
phi_launch_lu(11:20)=[93.12 93.12 93.12 93.12 93.12 93.12 93.12 93.12 93.12 93.12];
phi_launch_lu(21:30)=[93.12 93.12 93.12 93.12 93.12 93.12 93.12 93.12 93.12 93.12];
phi_launch_lu(31:40)=[93.12 93.12 93.12 93.12 93.12 93.12 93.12 93.12 93.12 93.12];
phi_launch_lu(41:50)=[93.12 93.12 93.12 93.12 93.12 93.12 93.12 93.12 93.12 93.12];
phi_launch_lu(51:60)=[93.12 93.12 93.12 93.12 93.12 93.12 93.12 93.12 93.12 93.12];
phi_launch_lu(61:70)=[93.12 93.12 93.12 93.12 93.12 93.12 93.12 93.12 93.12 93.12];
phi_launch_lu(71:80)=[93.12 93.12 93.12 93.12 93.12 93.12 93.12 93.12 93.12 93.12];
phi_launch_lu(81:90)=[93.12 93.12 93.12 93.12 93.12 93.12 93.12 93.12 93.12 93.12];
phi_launch_lu(91:100)=[93.12 93.12 93.12 93.12 93.12 93.12 93.12 93.12 93.12 93.12];
phi_launch_lu(101:110)=[93.12 93.12 93.12 93.12 93.12 93.12 93.12 93.12 93.12 93.12];
phi_launch_lu(111:120)=[93.12 93.12 93.12 93.12 93.12 93.12 93.12 93.12 93.12 93.12];
phi_launch_lu(121:130)=[93.365 93.358 93.423 93.306 93.194 93.366 93.442 93.407 93.197 93.181];
phi_launch_lu(131:140)=[93.254 93.354 93.373 93.260 93.148 93.423 93.359 93.224 93.171 93.266];
phi_launch_lu(141:150)=[93.402 93.232 93.229 93.212 93.390 93.368 93.382 93.411 93.198 93.206];
phi_launch_lu(151:160)=[93.255 93.203 93.419 93.451 93.232 93.378 93.410 93.379 93.210 93.236];
phi_launch_lu(161:170)=[93.416 93.424 93.391 93.227 93.231 93.430 93.393 93.387 93.213 93.427];
phi_launch_lu(171:181)=[93.256 93.450 93.233 93.245 93.247 93.244 93.415 93.234 93.233 93.252
93.402];

```

```

end;
elseif lethaldist==500

```

```

%SPECNET

```

```

%Define properties of expendable and sphere

```

```

%Sphere

```

```

W_sphere=5.2;

```

```

%Expendable

```

```

CD_exp=1.16;

```

```

S_exp=15.6;

```

```

W_exp=2.32;

```

```

%Define vectors to be used to determine expendable launch angle

```

%if there is a tracker on the A/C

```
%Define time required for expendable to get to target point on lethal sphere
time_lu(1:10)=[.1436 .1436 .1436 .1436 .1436 .1436 .1436 .1436 .1436];
time_lu(11:20)=[.1436 .1436 .1436 .1436 .1436 .1436 .1436 .1436 .1436 .1436];
time_lu(21:30)=[.1436 .1435 .1435 .1435 .1435 .1435 .1435 .1435 .1435 .1435];
time_lu(31:40)=[.1435 .1435 .1435 .1435 .1435 .1435 .1434 .1434 .1434 .1434];
time_lu(41:50)=[.1434 .1434 .1434 .1434 .1434 .1434 .1434 .1434 .1434 .1434];
time_lu(51:60)=[.1434 .1434 .1433 .1433 .1433 .1433 .1433 .1433 .1433 .1433];
time_lu(61:70)=[.1433 .1433 .1433 .1433 .1433 .1433 .1433 .1433 .1433 .1433];
time_lu(71:80)=[.1433 .1433 .1433 .1433 .1433 .1433 .1433 .1433 .1433 .1433];
time_lu(81:90)=[.1433 .1433 .1433 .1433 .1433 .1433 .1433 .1433 .1433 .1433];
time_lu(91:100)=[.1433 .1433 .1433 .1433 .1433 .1433 .1433 .1433 .1433 .1433];
time_lu(101:110)=[.1433 .1432 .1432 .1432 .1432 .1432 .1432 .1432 .1432 .1432];
time_lu(111:120)=[.1432 .1432 .1432 .1432 .1431 .1431 .1429 .1429 .1429 .1430];
time_lu(121:130)=[.1432 .1428 .1430 .1429 .1431 .1432 .1428 .1432 .1432 .1427];
time_lu(131:140)=[.1432 .1431 .1427 .1427 .1427 .1432 .1427 .1432 .1426 .1428];
time_lu(141:150)=[.1428 .1428 .1428 .1427 .1432 .1430 .1430 .1431 .1427 .1431];
time_lu(151:160)=[.1431 .1432 .1432 .1431 .1432 .1431 .1428 .1432 .1432 .1432];
time_lu(161:170)=[.1432 .1432 .1433 .1428 .1428 .1432 .1428 .1428 .1432 .1432];
time_lu(171:181)=[.1428 .1428 .1428 .1428 .1428 .1427 .1428 .1427 .1427 .1428];
```

```
%Define angle at which missile is coming at aircraft. This will always be 0-180 by 1 as shown below
theta_missile_lu=[0 1 2 3 4 5 6 7 8 9 10 11 12 13 14 15 16 17 18 19 20 21 22 23 24 25 26 27 28 29 30 31
32 33 34 35 36 37 38 39 40 41 42 43 44 45 46 47 48 49 50 51 52 53 54 55 56 57 58 59 60 61 62 63 64 65
66 67 68 69 70 71 72 73 74 75 76 77 78 79 80 81 82 83 84 85 86 87 88 89 90 91 92 93 94 95 96 97 98 99
100 101 102 103 104 105 106 107 108 109 110 111 112 113 114 115 116 117 118 119 120 121 122 123
124 125 126 127 128 129 130 131 132 133 134 135 136 137 138 139 140 141 142 143 144 145 146 147
148 149 150 151 152 153 154 155 156 157 158 159 160 161 162 163 164 165 166 167 168 169 170 171
172 173 174 175 176 177 178 179 180];
```

```
%Define angle at which launcher should be aimed corresponding to the angle at which the missile is
%coming at the aircraft shown above
```

```
theta_launch_lu(1:10)=[0 1 2 3 4 5 6 7 8 9];
theta_launch_lu(11:20)=[10 11 12 13 14 15 16 17 18 19];
theta_launch_lu(21:30)=[20 21 22 23 24 25 26 27 28 29];
theta_launch_lu(31:40)=[30 31 32 33 34 35 36 37 38 39];
theta_launch_lu(41:50)=[40 41 42 43 44 45 46 47 48 49];
theta_launch_lu(51:60)=[50 51 52 53 54 55 56 57 58 59];
theta_launch_lu(61:70)=[60 61 62 63 64 65 66 67 68 69];
theta_launch_lu(71:80)=[70 71 72 73 74 75 76 77 78 79];
theta_launch_lu(81:90)=[80 81 82 83 84 85 86 87 88 89];
theta_launch_lu(91:100)=[90 91 92 93 94 95 96 97 98 99];
theta_launch_lu(101:110)=[100 101 102 103 104 105 106 107 108 109];
theta_launch_lu(111:120)=[110 111 112 113 113.896 115.048 115.796 116.811 117.818 118.886];
theta_launch_lu(121:130)=[119.977 120.990 121.870 122.898 123.989 124.979 125.715 127.043 128.037
128.826];
theta_launch_lu(131:140)=[130.027 131.062 131.847 132.847 133.885 135.072 135.856 137.090 137.879
138.917];
theta_launch_lu(141:150)=[139.887 140.903 141.910 142.894 144.082 144.862 145.932 146.990 147.790
149.058];
theta_launch_lu(151:160)=[150.010 151.117 152.073 153.040 154.103 154.902 156.004 157.026 158.032
159.036];
```

```
theta_launch_lu(161:170)=[160.143 161.054 162.049 163.012 164.099 165.143 166.119 167.167 168.261  
169.156];  
theta_launch_lu(171:181)=[170.113 171.156 172.140 173.221 174.117 174.955 176.193 176.989 178.016  
178.970 180.117];
```

```
phi_launch_lu(1:10)=[93.12 93.12 93.12 93.12 93.12 93.12 93.12 93.12 93.12 93.12];  
phi_launch_lu(11:20)=[93.12 93.12 93.12 93.12 93.12 93.12 93.12 93.12 93.12 93.12];  
phi_launch_lu(21:30)=[93.12 93.12 93.12 93.12 93.12 93.12 93.12 93.12 93.12 93.12];  
phi_launch_lu(31:40)=[93.12 93.12 93.12 93.12 93.12 93.12 93.12 93.12 93.12 93.12];  
phi_launch_lu(41:50)=[93.12 93.12 93.12 93.12 93.12 93.12 93.12 93.12 93.12 93.12];  
phi_launch_lu(51:60)=[93.12 93.12 93.12 93.12 93.12 93.12 93.12 93.12 93.12 93.12];  
phi_launch_lu(61:70)=[93.12 93.12 93.12 93.12 93.12 93.12 93.12 93.12 93.12 93.12];  
phi_launch_lu(71:80)=[93.12 93.12 93.12 93.12 93.12 93.12 93.12 93.12 93.12 93.12];  
phi_launch_lu(81:90)=[93.12 93.12 93.12 93.12 93.12 93.12 93.12 93.12 93.12 93.12];  
phi_launch_lu(91:100)=[93.12 93.12 93.12 93.12 93.12 93.12 93.12 93.12 93.12 93.12];  
phi_launch_lu(101:110)=[93.12 93.12 93.12 93.12 93.12 93.12 93.12 93.12 93.12 93.12];  
phi_launch_lu(111:120)=[93.12 93.12 93.12 93.12 93.367 93.276 93.389 93.440 93.273 93.224];  
phi_launch_lu(121:130)=[93.212 93.192 93.270 93.265 93.231 93.236 93.301 93.420 93.175 93.244];  
phi_launch_lu(131:140)=[93.256 93.396 93.365 93.233 93.259 93.358 93.369 93.182 93.431 93.263];  
phi_launch_lu(141:150)=[93.230 93.367 93.222 93.389 93.201 93.402 93.202 93.175 93.230 93.433];  
phi_launch_lu(151:160)=[93.220 93.394 93.386 93.174 93.208 93.418 93.380 93.388 93.196 93.430];  
phi_launch_lu(161:170)=[93.432 93.400 93.196 93.182 93.245 93.443 93.434 93.455 93.449 93.418];  
phi_launch_lu(171:181)=[93.349 93.238 93.444 93.245 93.195 93.427 93.423 93.217 93.243 93.241  
93.216];
```

```
end; %end of expendable if statement;
```

```

%*****
% File: expdata1.m
% Used in BLOCK:
%
% Authors: Capt. Joel Hagan & Capt Brian Peterson, USAF
%         GSE-95D Air Force Institute of Technology
% Language: Matlab
% Project: AKKCT (Aircraft Kintetic Kill Countermeasures Technology)
% Last Updated: 31 OCT 95
%
% Function: This function defines some of the parameters for the different expendables
%          which could be used.
%
%          exp_type
%          1      iteration 2 Cherry bomb
%          2      iteration 2 DET NET
%          3      iteration 2 LEADS
%          4      iteration 2 SpecNet
%          5      iteration 2 Airbag
%          6      iteration 3 Cherry Bomb
%          7      iteration 3 DET NET
%          8      iteration 3 SpecNet
%          9      enlarged  DET NET
%*****

if exp_type==1      %Cherry Bomb
    expeff_maxradius=20;    %Define effective radius of expendable (ft)
    expeff_minpctradius=1;
    oper_duration=.1;      %Define time duration over which expendable is operational (seconds)
elseif exp_type==2  %DETNET
    expeff_maxradius=15;    %Define effective radius of expendable (ft)
    expeff_minpctradius=.75;
    oper_duration=3.5;      %Define time duration over which expendable is operational (seconds)
elseif exp_type==3  %PHALANX
    expeff_maxradius=1.2;    %Define effective radius of expendable (ft)
    expeff_minpctradius=1;
    oper_duration=2;      %Define time duration over which expendable is operational (seconds)
elseif exp_type==4  %SPECNET
    expeff_maxradius=18;    %Define effective radius of expendable (ft)
    expeff_minpctradius=.75;
    oper_duration=3.5;      %Define time duration over which expendable is operational (seconds)
elseif exp_type==5  %DUECE BAG
    expeff_maxradius=7.1;    %Define effective radius of expendable (ft)
    expeff_minpctradius=1;
    oper_duration=10;      %Define time duration over which expendable is operational (seconds)
elseif exp_type==6  %Cherry Bomb iteration 3
    expeff_maxradius=4.9;    %Define effective radius of expendable (ft)
    expeff_minpctradius=1;
    oper_duration=.002;      %Define time duration over which expendable is operational (seconds)
elseif exp_type==7  %DETNET iteration 3
    expeff_maxradius=10.21;    %Define effective radius of expendable (ft)
    expeff_minpctradius=.75;
    oper_duration=3.5;      %Define time duration over which expendable is operational (seconds)
elseif exp_type==8  %SpecNet iteration 3
    expeff_maxradius=11.4;    %Define effective radius of expendable (ft)

```



```
expeff_minpctradius=.75;
oper_duration=3.5;      %Define time duration over which expendable is operational (seconds)
elseif exp_type==9      %DETNET enlarged
expeff_maxradius=14.24; %Define effective radius of expendable (ft)
expeff_minpctradius=.75;
oper_duration=3.5;      %Define time duration over which expendable is operational (seconds)
```

```
end;
```

```

%*****
% File: records.m
% Used in newmess.m
%
% Authors: Capt. Joel Hagan & Capt Brian Peterson, USAF
%          GSE-95D Air Force Institute of Technology
% Language: Matlab
% Project: AKKCT (Aircraft Kintetic Kill Countermeasures Technology)
% Last Updated: 31 OCT 95
%
% Function: This function saved the important data from a simulation run for a single launch..
% If more than one simulation was run, the data for all of the runs were
% stored the specified output file in separate rows.
% Each row contained the following simulation run information:
%     PK
%     Time at which missile was launched (shottime)
%     Time after lmissile launch at which missile was detected (detecttal)
%     Time at which first expendable was launched (launchtime)
%     Time at which expendable became operational (opertimer)
%     Final time of simulation (maxtime)
%     Distance between missile and aircraft at simulation end (amrend)
%     Distance between missile and a/c at the time interval right before the simulation ended (amrb4end)
%     Distance between missile and expendable at simulation end (mexsr)
%     Minimum distance between expendable and missile (minmexsr)
%     The percent/100 of max expendable radius which was used for
%         expendable of simulation run (pct_radius)
%     The missile range at launch (missilerange)
%     Missilelaunch angle (missiletheta)
%     Expendable type (exp_type)
%     whether was tracker or detector (tracker)
%     Tracker angular error standard deviation (trackerstd)
%     Tracker range error standard deviation (rangestd)
%     Tracker velocity error standard deviation (missilevelstd)
%     Whether detector was imaging or gimbelled system (imaging)
%
%*****
%Remove leading zeros from expendable position and velocity
xexp=nonzeros(xexp);
yexp=nonzeros(yexp);
zexp=nonzeros(zexp);
vxexp=nonzeros(vxexp);
vyexp=nonzeros(vyexp);
vzexp=nonzeros(vzexp);

%Add a zero to the begining of the Y velocity vector. The velocity
%in the Y direction starts at zero but the procedure just above this
%one that removed all of the leading zeros from the expendable
%position and velocity vectors also removed this zero which actually
%was a valid point.

vyexp=[0;vyexp];

%Determine PK
Probability_of_kill=max(PK)

```

```

%Make calculations of any variable you wish to output.
maxtime=max(time)
if maxtime>24.99999
    Probability_of_kill=-1;
end;
launchtime=launch_time(size(launch_time,1));
sizemexslanrange=size(mexslanrange);
mexsr=mexslanrange(sizemexslanrange(1,1));
minmexsr=min(mexslanrange((launchtime+.010)*1000:sizemexslanrange(1,1)));
opertimer=opertime(size(opertime,1));

amrend=amslanrange(size(amslanrange,1));
amrb4end=amslanrange(size(amslanrange,1)-1);

%Print pertinent data to output file.
fprintf(outfid,'%3.1f %6.3f %6.3f %6.3f %6.3f %6.3f %6.2f %6.2f %6.2f %6.2f %6.2f %6.2f %6.6f %3.1f
%3.1f %6.3f %6.3f %6.3f %3.1f\n',...
[Probability_of_kill shottime detecttal launchtime opertimer maxtime amrend amrb4end mexsr minmexsr
pct_radius missilerange...
missiletheta exp_type tracker trackerstd rangestd missilelevelstd imaging]);

```

```

%*****
% File: plotits.m
% Used in newmess.m
%
% Authors: Capt. Joel Hagan & Capt Brian Peterson, USAF
%          GSE-95D Air Force Institute of Technology
% Language: Matlab
% Project: AKKCT (Aircraft Kintetic Kill Countermeasures Technology)
% Last Updated: 31 OCT 95
%
% Function: This function first plots an overall 3-D view of the single launch scenario
% with a sphere showing the lethal distance around the aircraft. then, in a second plot,
% plots and endgame view of the scenario from four different aspects so it is easier
% to see what happened right before the simulation ended.
% Uses: endgame.m and sphere.m
%
%*****
%%Plot A/C, missile, expendable trajectory
figure
plot3(xac,yac,zac,xm,ym,zm,xexp,yexp,zexp);
hold;

%%Plot lethal sphere
sizex0=size(xac);
sizey0=size(yac);
sizez0=size(zac);
x0sphere=xac(sizex0(1)-1);
y0sphere=yac(sizey0(1)-1);
z0sphere=zac(sizez0(1)-1);
sphere(x0sphere,y0sphere,z0sphere,lethaldist);
hold;

%%Plot endgame figures
figure
subplot(2,2,1);
endgame;
subplot(2,2,2);
endgame;
view(0,0);
subplot(2,2,3);
endgame;
view(90,0);
subplot(2,2,4);
endgame;
view(0,90);

```

```

%*****
% file: endgame.m
% Used in plotits.m
%
% Authors: Capt. Joel Hagan & Capt Brian Peterson, USAF
%         GSE-95D Air Force Institute of Technology
% Language: Matlab
% Project: AKKCT (Aircraft Kintetic Kill Countermeasures Technology)
% Last Updated: 31 OCT 95
%
% Function: This plots the simulation with a single expendable
%          in three dimensions in figure 1 and a closer view in 3 and 2
%          dimensions from different angles
%
%*****

%Plot A/C, missile, expendable trajectory
plot3(xac,yac,zac,xm,ym,zm,xexp,yexp,zexp);
hold;

%Plot lethal sphere
sizex0=size(xac);
sizey0=size(yac);
sizez0=size(zac);
x0sphere=xac(sizex0(1)-1);
y0sphere=yac(sizey0(1)-1);
z0sphere=zac(sizez0(1)-1);
sphere(x0sphere,y0sphere,z0sphere,lethaldist);
hold;

%Scale axes
axis([x0sphere-250,x0sphere+250,y0sphere-250,y0sphere+250,z0sphere-250,z0sphere+250]);

```

```

function h=sphere(x0,y0,z0,r)
%*****
% File: sphere.m
% Used in records.m & recordm.m
%
% Authors: Capt. Joel Hagan & Capt Brian Peterson, USAF
%         GSE-95D Air Force Institute of Technology
% Language: Matlab
% Project: AKKCT (Aircraft Kintetic Kill Countermeasures Technology)
% Last Updated: 31 OCT 95
%
% Function: This function draws three circles; one in the XY plane;
% one in the XZ plane and one in the YZ plane. All
% circles are centered about (x0,y0,z0) and have radius r.
%
%*****

phi=1.570796;
for theta=0:.01:6.283
    xcircle(theta.*10+1,phi.*10+1)=x0+(r.*sin(phi).*cos(theta));
    ycircle(theta.*10+1,phi.*10+1)=y0+(r.*sin(phi).*sin(theta));
    zcircle(theta.*10+1,phi.*10+1)=z0+(r.*cos(phi));

    x1circle(theta.*10+1,phi.*10+1)=z0+(r.*sin(phi).*cos(theta));
    y1circle(theta.*10+1,phi.*10+1)=y0+(r.*sin(phi).*sin(theta));
    z1circle(theta.*10+1,phi.*10+1)=x0+(r.*cos(phi));

    x2circle(theta.*10+1,phi.*10+1)=z0+(r.*sin(phi).*cos(theta));
    y2circle(theta.*10+1,phi.*10+1)=x0+(r.*sin(phi).*sin(theta));
    z2circle(theta.*10+1,phi.*10+1)=y0+(r.*cos(phi));

end

plot3(xcircle,ycircle,zcircle,z1circle,y1circle,x1circle,y2circle,z2circle,x2circle);
xlabel('x');
ylabel('y');
zlabel('z');
%clear xcircle ycircle zcircle;

```

```

%*****
% File: recordm.m
% Used in newmess.m
%
% Authors: Capt. Joel Hagan & Capt Brian Peterson, USAF
%          GSE-95D Air Force Institute of Technology
% Language: Matlab
% Project: AKKCT (Aircraft Kintetic Kill Countermeasures Technology)
% Last Updated: 31 OCT 95
%
% Function: This function saved the important data from a simulation run.
% If more than one simulation was run, the data for all of the runs were
% stored the specified output file in separate rows.
% Each row contained the following simulation run information:
%   PK (1-7)
%   Time at which missile was launched (shottime)
%   Time after lmissile launch at which missile was detected (detecttal)
%   Time at which first expendable was launched (launchtime)
%   Time at which each expendable became operational (1-7) (opertimer)
%   Final time of simulation (maxtime)
%   Distance between missile and aircraft at simulation end (amrend)
%   Distance between missile and a/c at the time interval right before the simulation ended (amrb4end)
%   Distance between missile and each expendable at simulation end (mexsr)
%   Minimum distance between each expendable and missile (minmexsr)
%   The percent/100 of max expendable radius which was used for
%       each expendable of simulation run (pct_radius)
%   The missile range at launch (missilerange)
%   Missilelaunch angle (missiletheta)
%   Expendable type (exp_type)
%   whether was tracker or detector (tracker)
%   Tracker angular error standard deviation (trackerstd)
%   Tracker range error standard deviation (rangestd)
%   Tracker velocity error standard deviation (missilevelstd)
%   Whether detector was imaging or gimbelled system (imaging)
%
%*****

%Remove leading zeros from expendable position and velocity
xexp1=nonzeros(xexp1);
yexp1=nonzeros(yexp1);
zexp1=nonzeros(zexp1);
xexp2=nonzeros(xexp2);
yexp2=nonzeros(yexp2);
zexp2=nonzeros(zexp2);
xexp3=nonzeros(xexp3);
yexp3=nonzeros(yexp3);
zexp3=nonzeros(zexp3);
xexp4=nonzeros(xexp4);
yexp4=nonzeros(yexp4);
zexp4=nonzeros(zexp4);
xexp5=nonzeros(xexp5);
yexp5=nonzeros(yexp5);
zexp5=nonzeros(zexp5);
xexp6=nonzeros(xexp6);
yexp6=nonzeros(yexp6);

```

```

zexp6=nonzeros(zexp6);
xexp7=nonzeros(xexp7);
yexp7=nonzeros(yexp7);
zexp7=nonzeros(zexp7);
vxexp1=nonzeros(vxexp1);
vyexp1=nonzeros(vyexp1);
vzexp1=nonzeros(vzexp1);
vxexp2=nonzeros(vxexp2);
vyexp2=nonzeros(vyexp2);
vzexp2=nonzeros(vzexp2);
vxexp3=nonzeros(vxexp3);
vyexp3=nonzeros(vyexp3);
vzexp3=nonzeros(vzexp3);
vxexp4=nonzeros(vxexp4);
vyexp4=nonzeros(vyexp4);
vzexp4=nonzeros(vzexp4);
vxexp5=nonzeros(vxexp5);
vyexp5=nonzeros(vyexp5);
vzexp5=nonzeros(vzexp5);
vxexp6=nonzeros(vxexp6);
vyexp6=nonzeros(vyexp6);
vzexp6=nonzeros(vzexp6);
vxexp7=nonzeros(vxexp7);
vyexp7=nonzeros(vyexp7);
vzexp7=nonzeros(vzexp7);

```

```

%Add a zero to the begining of the Y velocity vector. The velocity
%in the Y direction starts at zero but the procedure just above this
%one that removed all of the leading zeros from the expendable
%position and velocity vectors also removed this zero which actually
%was a valid point.

```

```

vyexp1=[0;vyexp1];
vyexp2=[0;vyexp2];
vyexp3=[0;vyexp3];
vyexp4=[0;vyexp4];
vyexp5=[0;vyexp5];
vyexp6=[0;vyexp6];
vyexp7=[0;vyexp7];

```

```

%Make calculations of any variable you wish to output.

```

```

maxtime=max(time)
if maxtime>24.9999999

```

```

    PK(1,1)=-1;

```

```

end;

```

```

launchtime=launch_time(size(launch_time,1));

```

```

sizemexslanrange=size(mexslanrange1);

```

```

mexsr(1,1)=mexslanrange1(sizemexslanrange(1,1));

```

```

mexsr(1,2)=mexslanrange2(sizemexslanrange(1,1));

```

```

mexsr(1,3)=mexslanrange3(sizemexslanrange(1,1));

```

```

mexsr(1,4)=mexslanrange4(sizemexslanrange(1,1));

```

```

mexsr(1,5)=mexslanrange5(sizemexslanrange(1,1));

```

```

mexsr(1,6)=mexslanrange6(sizemexslanrange(1,1));

```

```

mexsr(1,7)=mexslanrange7(sizemexslanrange(1,1));

```



```

%*****
% File: plotitm.m
% Used in newmess.m
%
% Authors: Capt. Joel Hagan & Capt Brian Peterson, USAF
%          GSE-95D Air Force Institute of Technology
% Language: Matlab
% Project: AKKCT (Aircraft Kintetic Kill Countermeasures Technology)
% Last Updated: 31 OCT 95
%
% Function: This function first plots an overall 3-D view of the multiple launch scenario
% with a sphere showing the lethal distance around the aircraft. then, in a second plot,
% plots and endgame view of the scenario from four different aspects so it is easier
% to see what happened right before the simulation ended.
% Uses: endgamem.m and sphere.m
%
%*****

%Plot A/C, missile, expendable trajectory
figure
plot3(xac,yac,zac,xm,ym,zm,xexp1,yexp1,zexp1,xexp2,yexp2,zexp2,xexp3,yexp3,zexp3,xexp4,yexp4,zexp
4,xexp5,yexp5,zexp5,xexp6,yexp6,zexp6,xexp7,yexp7,zexp7);
hold;

%Plot lethal sphere
sizeX0=size(xac);
sizeY0=size(yac);
sizeZ0=size(zac);
x0sphere=xac(sizeX0(1)-1);
y0sphere=yac(sizeY0(1)-1);
z0sphere=zac(sizeZ0(1)-1);
sphere(x0sphere,y0sphere,z0sphere,lethaldist);
hold;

%Plot endgame figures
figure
subplot(2,2,1);
endgamem;
subplot(2,2,2);
endgamem;
view(0,0);
subplot(2,2,3);
endgamem;
view(90,0);
subplot(2,2,4);
endgamem;
view(0,90);

```

```

%*****
% file: endgamem.m
% Used in plotism.m
%
% Authors: Capt. Joel Hagan & Capt Brian Peterson, USAF
%         GSE-95D Air Force Institute of Technology
% Language: Matlab
% Project: AKKCT (Aircraft Kintetic Kill Countermeasures Technology)
% Last Updated: 31 OCT 95
%
% Function: This function plots the simulation with multiple expendables
%          in three dimensions in figure 1 and a closer view in 3 and 2
%          dimensions from different angles
%
%*****

%Plot A/C, missile, expendable trajectory
plot3(xac,yac,zac,xm,ym,zm,xexp1,yexp1,zexp1,xexp2,yexp2,zexp2,xexp3,yexp3,zexp3,...
      xexp4,yexp4,zexp4,xexp5,yexp5,zexp5,xexp6,yexp6,zexp6,xexp7,yexp7,zexp7);

hold;

%Plot lethal sphere
sizex0=size(xac);
sizey0=size(yac);
sizez0=size(zac);
x0sphere=xac(sizex0(1)-1);
y0sphere=yac(sizey0(1)-1);
z0sphere=zac(sizez0(1)-1);
sphere(x0sphere,y0sphere,z0sphere,lethaldist);
hold;

%Scale axes
axis([x0sphere-(lethaldist+150),x0sphere+(lethaldist+150),y0sphere-(lethaldist+150),...
y0sphere+(lethaldist+150),z0sphere-(lethaldist+150),z0sphere+(lethaldist+150)]);

```

```

function [ret,x0,str,ts,xts]=acmeblk(t,x,u,flag);
%ACMEBLCK is the M-file description of the SIMULINK system named ACMEBLCK.
% The block-diagram can be displayed by typing: ACMEBLCK.
%
% SYS=ACMEBLCK(T,X,U,FLAG) returns depending on FLAG certain
% system values given time point, T, current state vector, X,
% and input vector, U.
% FLAG is used to indicate the type of output to be returned in SYS.
%
% Setting FLAG=1 causes ACMEBLCK to return state derivatives, FLAG=2
% discrete states, FLAG=3 system outputs and FLAG=4 next sample
% time. For more information and other options see SFUNC.
%
% Calling ACMEBLCK with a FLAG of zero:
% [SIZES]=ACMEBLCK([],[],[],0), returns a vector, SIZES, which
% contains the sizes of the state vector and other parameters.
% SIZES(1) number of states
% SIZES(2) number of discrete states
% SIZES(3) number of outputs
% SIZES(4) number of inputs
% SIZES(5) number of roots (currently unsupported)
% SIZES(6) direct feedthrough flag
% SIZES(7) number of sample times
%
% For the definition of other parameters in SIZES, see SFUNC.
% See also, TRIM, LINMOD, LINSIM, EULER, RK23, RK45, ADAMS, GEAR.

% Note: This M-file is only used for saving graphical information;
% after the model is loaded into memory an internal model
% representation is used.

% the system will take on the name of this mfile:
sys = mfilename;
new_system(sys)
simver(1.3)
if (0 == (nargin + nargout))
    set_param(sys,'Location',[4,42,628,468])
    open_system(sys)
end;
set_param(sys,'algorithm', 'Linear')
set_param(sys,'Start time', '0.0')
set_param(sys,'Stop time', '80')
set_param(sys,'Min step size', '0.001')
set_param(sys,'Max step size', '0.001')
set_param(sys,'Relative error','1e-3')
set_param(sys,'Return vars', '')

% Subsystem 'A/C'.

new_system([sys,','A/C'])
set_param([sys,','A/C'],'Location',[102,224,1134,817])

add_block('built-in/To Workspace',[sys,','A/C/zac1'])
set_param([sys,','A/C/zac1'],...

```

```

        'mat-name','zac',...
        'buffer','1000000000',...
        'position',[730,132,780,148])

add_block('built-in/To Workspace',[sys,'/','A//C/yac1'])
set_param([sys,'/','A//C/yac1'],...
        'mat-name','yac',...
        'buffer','1000000000',...
        'position',[865,407,915,423])

add_block('built-in/Mux',[sys,'/','A//C/ac pos'])
set_param([sys,'/','A//C/ac pos'],...
        'orientation',1,...
        'inputs',3,...
        'position',[914,365,966,405])

add_block('built-in/To Workspace',[sys,'/','A//C/xac1'])
set_param([sys,'/','A//C/xac1'],...
        'mat-name','xac',...
        'buffer','1000000000',...
        'position',[890,217,940,233])

add_block('built-in/Sum',[sys,'/','A//C/Sum13'])
set_param([sys,'/','A//C/Sum13'],...
        'inputs','+-',...
        'position',[820,259,840,281])

add_block('built-in/Sum',[sys,'/','A//C/Sumn3c'])
set_param([sys,'/','A//C/Sumn3c'],...
        'position',[745,338,770,362])

add_block('built-in/Gain',[sys,'/','A//C/Gain2'])
set_param([sys,'/','A//C/Gain2'],...
        'Gain','-1',...
        'position',[810,340,830,360])

add_block('built-in/Product',[sys,'/','A//C/m22'])
set_param([sys,'/','A//C/m22'],...
        'position',[600,480,625,500])

add_block('built-in/Constant',[sys,'/','A//C/AC crosswind'])
set_param([sys,'/','A//C/AC crosswind'],...
        'Value','acrosswind',...
        'position',[460,455,555,475])

add_block('built-in/White Noise',[sys,'/','A//C/White Noise',13,'3'])
set_param([sys,'/','A//C/White Noise',13,'3'],...
        'Seed','noiseseed(3)',...
        'position',[435,395,455,415])

% Subsystem ['A//C/hold3',13,'sample=1'].

new_system([sys,'/','A//C/hold3',13,'sample=1'])
set_param([sys,'/','A//C/hold3',13,'sample=1'],'Location',[511,151,915,322])

```

```

add_block('built-in/Zero-Order Hold',[sys,'/','A//C/hold3',13,'sample=1/Zero-Order',13,'Hold'])
set_param([sys,'/','A//C/hold3',13,'sample=1/Zero-Order',13,'Hold'],...
    'Sample time','Ts',...
    'position',[100,29,135,61])

add_block('built-in/Gain',[sys,'/','A//C/hold3',13,'sample=1/Gain'])
set_param([sys,'/','A//C/hold3',13,'sample=1/Gain'],...
    'Gain','1/Ts',...
    'position',[285,33,325,77])

add_block('built-in/Integrator',[sys,'/','A//C/hold3',13,'sample=1/Integrator'])
set_param([sys,'/','A//C/hold3',13,'sample=1/Integrator'],...
    'position',[235,42,260,68])

add_block('built-in/Sum',[sys,'/','A//C/hold3',13,'sample=1/Sum'])
set_param([sys,'/','A//C/hold3',13,'sample=1/Sum'],...
    'inputs','+','...',...
    'position',[190,37,210,68])

add_block('built-in/Unit Delay',[sys,'/','A//C/hold3',13,'sample=1/Unit Delay'])
set_param([sys,'/','A//C/hold3',13,'sample=1/Unit Delay'],...
    'Sample time','Ts',...
    'position',[90,93,140,117])

add_block('built-in/Inport',[sys,'/','A//C/hold3',13,'sample=1/input'])
set_param([sys,'/','A//C/hold3',13,'sample=1/input'],...
    'position',[25,35,45,55])

add_block('built-in/Outport',[sys,'/','A//C/hold3',13,'sample=1/output'])
set_param([sys,'/','A//C/hold3',13,'sample=1/output'],...
    'position',[345,45,365,65])
add_line([sys,'/','A//C/hold3',13,'sample=1'],[330,55;340,55])
add_line([sys,'/','A//C/hold3',13,'sample=1'],[265,55;280,55])
add_line([sys,'/','A//C/hold3',13,'sample=1'],[215,55;230,55])
add_line([sys,'/','A//C/hold3',13,'sample=1'],[145,105;165,105;165,60;185,60])
add_line([sys,'/','A//C/hold3',13,'sample=1'],[140,45;185,45])
add_line([sys,'/','A//C/hold3',13,'sample=1'],[50,45;95,45])
add_line([sys,'/','A//C/hold3',13,'sample=1'],[65,45;65,105;85,105])
set_param([sys,'/','A//C/hold3',13,'sample=1'],...
    'Mask Display','plot(0,0,100,100,[90,70,50,30,10],[60,40,80,30,20])',...
    'Mask Type','First-Order Hold',...
    'Mask Dialogue','First-Order Hold|Sample Time:',...
    'Mask Translate','Ts=@ 1;')
set_param([sys,'/','A//C/hold3',13,'sample=1'],...
    'Mask Help','Implements a First-Order sample-and-hold latch operating at the sampling
interval you specify.',...
    'Mask Entries','1V')

% Finished composite block ['A//C/hold3',13,'sample=1'].

set_param([sys,'/','A//C/hold3',13,'sample=1'],...
    'position',[490,389,525,421])

```

```

add_block('built-in/Product',[sys,'/','A//C/Productn3'])
set_param([sys,'/','A//C/Productn3'],...
           'position',[560,390,585,410])

add_block('built-in/Sum',[sys,'/','A//C/Sumn3a'])
set_param([sys,'/','A//C/Sumn3a'],...
           'position',[655,383,680,407])

add_block('built-in/Mux',[sys,'/','A//C/Mux16'])
set_param([sys,'/','A//C/Mux16'],...
           'inputs',2,...
           'position',[625,181,655,214])

add_block('built-in/Fcn',[sys,'/','A//C/Fcn'])
set_param([sys,'/','A//C/Fcn'],...
           'position',[370,148,445,172])

add_block('built-in/Fcn',[sys,'/','A//C/Fcn6'])
set_param([sys,'/','A//C/Fcn6'],...
           'Expr','cos(u[1])',...
           'position',[490,274,570,296])

add_block('built-in/Fcn',[sys,'/','A//C/Fcn4'])
set_param([sys,'/','A//C/Fcn4'],...
           'position',[490,339,570,361])

add_block('built-in/Product',[sys,'/','A//C/Product'])
set_param([sys,'/','A//C/Product'],...
           'position',[485,155,510,175])

add_block('built-in/Integrator',[sys,'/','A//C/Int1'])
set_param([sys,'/','A//C/Int1'],...
           'position',[550,155,570,175])

add_block('built-in/Integrator',[sys,'/','A//C/Int'])
set_param([sys,'/','A//C/Int'],...
           'position',[550,215,570,235])

add_block('built-in/Fcn',[sys,'/','A//C/Fcn1'])
set_param([sys,'/','A//C/Fcn1'],...
           'Expr','cos(u[1])',...
           'position',[365,219,445,241])

add_block('built-in/Product',[sys,'/','A//C/Product1'])
set_param([sys,'/','A//C/Product1'],...
           'position',[485,215,510,235])

add_block('built-in/Product',[sys,'/','A//C/m5'])
set_param([sys,'/','A//C/m5'],...
           'position',[605,300,630,320])

add_block('built-in/Product',[sys,'/','A//C/m4'])
set_param([sys,'/','A//C/m4'],...
           'position',[600,265,625,285])

```

```

add_block('built-in/Note',[sys,'/','A//C/c'])
set_param([sys,'/','A//C/c'],...
    'position',[645,260,650,265])

add_block('built-in/Note',[sys,'/','A//C/d'])
set_param([sys,'/','A//C/d'],...
    'position',[645,310,650,315])

add_block('built-in/White Noise',[sys,'/','A//C/White Noise',13,'1'])
set_param([sys,'/','A//C/White Noise',13,'1'],...
    'Seed',noiseseed(1),...
    'position',[85,45,105,65])

add_block('built-in/Product',[sys,'/','A//C/mn1'])
set_param([sys,'/','A//C/mn1'],...
    'position',[225,95,250,115])

add_block('built-in/Sum',[sys,'/','A//C/sumn1b'])
set_param([sys,'/','A//C/sumn1b'],...
    'position',[290,100,310,120])

add_block('built-in/Constant',[sys,'/','A//C/a/c climb',13,'velocity',13,''])
set_param([sys,'/','A//C/a/c climb',13,'velocity',13,''],...
    'Value','acvel',...
    'position',[170,147,210,163])

add_block('built-in/Constant',[sys,'/','A//C/AC Velocity',13,'Noise std dev'])
set_param([sys,'/','A//C/AC Velocity',13,'Noise std dev'],...
    'Value','acvelstd',...
    'position',[85,100,145,120])

% Subsystem ['A//C/hold1',13,'sample=.25'].

new_system([sys,'/','A//C/hold1',13,'sample=.25'])
set_param([sys,'/','A//C/hold1',13,'sample=.25'],'Location',[511,151,915,322])

add_block('built-in/Zero-Order Hold',[sys,'/','A//C/hold1',13,'sample=.25/Zero-Order',13,'Hold'])
set_param([sys,'/','A//C/hold1',13,'sample=.25/Zero-Order',13,'Hold'],...
    'Sample time','Ts',...
    'position',[100,29,135,61])

add_block('built-in/Gain',[sys,'/','A//C/hold1',13,'sample=.25/Gain'])
set_param([sys,'/','A//C/hold1',13,'sample=.25/Gain'],...
    'Gain','1/Ts',...
    'position',[285,33,325,77])

add_block('built-in/Integrator',[sys,'/','A//C/hold1',13,'sample=.25/Integrator'])
set_param([sys,'/','A//C/hold1',13,'sample=.25/Integrator'],...
    'position',[235,42,260,68])

add_block('built-in/Sum',[sys,'/','A//C/hold1',13,'sample=.25/Sum'])
set_param([sys,'/','A//C/hold1',13,'sample=.25/Sum'],...
    'inputs','+',...
    'position',[190,37,210,68])

```



```

add_block('built-in/Unit Delay',[sys,/,['A//C/hold 1',13,'sample=.25/Unit Delay']]
set_param([sys,/,['A//C/hold 1',13,'sample=.25/Unit Delay']],...
          'Sample time','Ts',...
          'position',[90,93,140,117])

add_block('built-in/Inport',[sys,/,['A//C/hold 1',13,'sample=.25/input']]
set_param([sys,/,['A//C/hold 1',13,'sample=.25/input']],...
          'position',[25,35,45,55])

add_block('built-in/Outport',[sys,/,['A//C/hold 1',13,'sample=.25/output']]
set_param([sys,/,['A//C/hold 1',13,'sample=.25/output']],...
          'position',[345,45,365,65])
add_line([sys,/,['A//C/hold 1',13,'sample=.25']], [330,55;340,55])
add_line([sys,/,['A//C/hold 1',13,'sample=.25']], [265,55;280,55])
add_line([sys,/,['A//C/hold 1',13,'sample=.25']], [215,55;230,55])
add_line([sys,/,['A//C/hold 1',13,'sample=.25']], [145,105;165,105;165,60;185,60])
add_line([sys,/,['A//C/hold 1',13,'sample=.25']], [140,45;185,45])
add_line([sys,/,['A//C/hold 1',13,'sample=.25']], [50,45;95,45])
add_line([sys,/,['A//C/hold 1',13,'sample=.25']], [65,45;65,105;85,105])
set_param([sys,/,['A//C/hold 1',13,'sample=.25']],...
          'Mask Display','plot(0,0,100,100,[90,70,50,30,10],[60,40,80,30,20])',...
          'Mask Type','First-Order Hold',...
          'Mask Dialogue','First-Order Hold(Sample Time:)'
set_param([sys,/,['A//C/hold 1',13,'sample=.25']],...
          'Mask Translate','Ts=@ 1',...
          'Mask Help','Implements a First-Order sample-and-hold latch operating at the sampling
interval you specify.',...
          'Mask Entries','.25V')

% Finished composite block ['A//C/hold 1',13,'sample=.25'].

set_param([sys,/,['A//C/hold 1',13,'sample=.25']],...
          'position',[145,39,180,71])

add_block('built-in/Outport',[sys,/, 'A//C/AC velocity (z,x)'])
set_param([sys,/, 'A//C/AC velocity (z,x)'],...
          'position',[1020,190,1040,210])

add_block('built-in/Outport',[sys,/, 'A//C/AC position (x,y,z)'])
set_param([sys,/, 'A//C/AC position (x,y,z)'],...
          'orientation',1,...
          'Port','2',...
          'position',[1005,430,1025,450])

add_block('built-in/Constant',[sys,/,['A//C/a/c climb',13,'angle 1']]
set_param([sys,/,['A//C/a/c climb',13,'angle 1']],...
          'Value','acclimbangle',...
          'position',[120,342,205,358])

add_block('built-in/Sum',[sys,/, 'A//C/Sumn2b'])
set_param([sys,/, 'A//C/Sumn2b'],...
          'position',[235,295,255,315])

```

```

add_block('built-in/Constant',[sys,/,['A//C/Ac Angle',13,'std dev']])
set_param([sys,/,['A//C/Ac Angle',13,'std dev']],...
    'Value','acangstd',...
    'position',[70,305,125,325])

add_block('built-in/Product',[sys,/,['A//C/mn2']])
set_param([sys,/,['A//C/mn2']],...
    'position',[180,290,205,310])

% Subsystem ['A//C/hold2',13,'sample=1'].

new_system([sys,/,['A//C/hold2',13,'sample=1']])
set_param([sys,/,['A//C/hold2',13,'sample=1']], 'Location',[511,151,915,322])

add_block('built-in/Zero-Order Hold',[sys,/,['A//C/hold2',13,'sample=1/Zero-Order',13,'Hold']])
set_param([sys,/,['A//C/hold2',13,'sample=1/Zero-Order',13,'Hold']],...
    'Sample time','Ts',...
    'position',[100,29,135,61])

add_block('built-in/Gain',[sys,/,['A//C/hold2',13,'sample=1/Gain']])
set_param([sys,/,['A//C/hold2',13,'sample=1/Gain']],...
    'Gain','1/Ts',...
    'position',[285,33,325,77])

add_block('built-in/Integrator',[sys,/,['A//C/hold2',13,'sample=1/Integrator']])
set_param([sys,/,['A//C/hold2',13,'sample=1/Integrator']],...
    'position',[235,42,260,68])

add_block('built-in/Sum',[sys,/,['A//C/hold2',13,'sample=1/Sum']])
set_param([sys,/,['A//C/hold2',13,'sample=1/Sum']],...
    'inputs','+-',...
    'position',[190,37,210,68])

add_block('built-in/Unit Delay',[sys,/,['A//C/hold2',13,'sample=1/Unit Delay']])
set_param([sys,/,['A//C/hold2',13,'sample=1/Unit Delay']],...
    'Sample time','Ts',...
    'position',[90,93,140,117])

add_block('built-in/Inport',[sys,/,['A//C/hold2',13,'sample=1/input']])
set_param([sys,/,['A//C/hold2',13,'sample=1/input']],...
    'position',[25,35,45,55])

add_block('built-in/Outport',[sys,/,['A//C/hold2',13,'sample=1/output']])
set_param([sys,/,['A//C/hold2',13,'sample=1/output']],...
    'position',[345,45,365,65])
add_line([sys,/,['A//C/hold2',13,'sample=1']], [330,55;340,55])
add_line([sys,/,['A//C/hold2',13,'sample=1']], [265,55;280,55])
add_line([sys,/,['A//C/hold2',13,'sample=1']], [215,55;230,55])
add_line([sys,/,['A//C/hold2',13,'sample=1']], [145,105;165,105;165,60;185,60])
add_line([sys,/,['A//C/hold2',13,'sample=1']], [140,45;185,45])
add_line([sys,/,['A//C/hold2',13,'sample=1']], [50,45;95,45])
add_line([sys,/,['A//C/hold2',13,'sample=1']], [65,45;65,105;85,105])
set_param([sys,/,['A//C/hold2',13,'sample=1']],...
    'Mask Display',plot(0,0,100,100,[90,70,50,30,10],[60,40,80,30,20]),...

```

```

'Mask Type','First-Order Hold',...
'Mask Dialogue','First-Order Hold|Sample Time:',...
'Mask Translate','Ts=@ 1;')
set_param([sys,'/','A//C/hold2',13,'sample=1'],...
'Mask Help','Implements a First-Order sample-and-hold latch operating at the sampling
interval you specify.',...
'Mask Entries','1V')

```

```

% Finished composite block ['A//C/hold2',13,'sample=1'].

```

```

set_param([sys,'/','A//C/hold2',13,'sample=1'],...
'position',[120,239,155,271])

```

```

add_block('built-in/White Noise',[sys,'/','A//C/White Noise',13,'2'])
set_param([sys,'/','A//C/White Noise',13,'2'],...
'Seed','noiseseed(2)',...
'position',[70,245,90,265])

```

```

add_block('built-in/Constant',[sys,'/','A//C/Missile range ',13,'from A//C rotation'])
set_param([sys,'/','A//C/Missile range ',13,'from A//C rotation'],...
'Value','missilerange',...
'position',[340,296,420,314])

```

```

add_block('built-in/Constant',[sys,'/','A//C/Initial missile angle',13,'in XY plane'])
set_param([sys,'/','A//C/Initial missile angle',13,'in XY plane'],...
'Value','missiletheta',...
'position',[335,341,425,359])

```

```

add_block('built-in/Inport',[sys,'/','A//C/Time'])
set_param([sys,'/','A//C/Time'],...
'position',[345,485,365,505])

```

```

add_block('built-in/Constant',[sys,'/','A//C/ACypos ',13,'std dev.'])
set_param([sys,'/','A//C/ACypos ',13,'std dev.'],...
'Value','acystd',...
'position',[365,440,420,460])

```

```

add_block('built-in/Note',[sys,'/','A//C/BLOCK: A//C'])
set_param([sys,'/','A//C/BLOCK: A//C'],...
'position',[500,550,505,555])
add_line([sys,'/','A//C'],[575,165;955,165;955,360])
add_line([sys,'/','A//C'],[685,165;685,140;725,140])
add_line([sys,'/','A//C'],[835,350;940,360])
add_line([sys,'/','A//C'],[845,350;845,415;860,415])
add_line([sys,'/','A//C'],[845,270;925,270;925,360])
add_line([sys,'/','A//C'],[875,270;885,225])
add_line([sys,'/','A//C'],[590,400;615,400;615,390;650,390])
add_line([sys,'/','A//C'],[630,490;635,490;635,400;650,400])
add_line([sys,'/','A//C'],[560,465;570,465;570,485;595,485])
add_line([sys,'/','A//C'],[460,405;485,405])
add_line([sys,'/','A//C'],[530,405;535,405;535,395;555,395])
add_line([sys,'/','A//C'],[685,395;720,395;720,355;740,355])
add_line([sys,'/','A//C'],[130,315;145,315;145,305;175,305])
add_line([sys,'/','A//C'],[160,255;165,255;175,295])

```

```

add_line([sys,'/','A//C'],[95,255;115,255])
add_line([sys,'/','A//C'],[210,300;230,300])
add_line([sys,'/','A//C'],[150,110;220,110])
add_line([sys,'/','A//C'],[255,105;285,105])
add_line([sys,'/','A//C'],[185,55;205,55;205,100;220,100])
add_line([sys,'/','A//C'],[110,55;140,55])
add_line([sys,'/','A//C'],[515,225;545,225])
add_line([sys,'/','A//C'],[525,225;525,205;620,205])
add_line([sys,'/','A//C'],[515,165;545,165])
add_line([sys,'/','A//C'],[525,165;525,190;620,190])
add_line([sys,'/','A//C'],[775,350;805,350])
add_line([sys,'/','A//C'],[635,310;680,310;680,345;740,345])
add_line([sys,'/','A//C'],[425,450;541,450;541,405;555,405])
add_line([sys,'/','A//C'],[260,305;315,305;315,160;365,160])
add_line([sys,'/','A//C'],[315,230;360,230])
add_line([sys,'/','A//C'],[210,350;215,350;215,310;230,310])
add_line([sys,'/','A//C'],[315,110;455,110;455,190;465,190;465,220;480,220])
add_line([sys,'/','A//C'],[465,190;465,170;480,170])
add_line([sys,'/','A//C'],[215,155;272,155;272,115;285,115])
add_line([sys,'/','A//C'],[575,285;580,280;595,280])
add_line([sys,'/','A//C'],[575,350;585,350;585,315;600,315])
add_line([sys,'/','A//C'],[425,305;600,305])
add_line([sys,'/','A//C'],[425,305;455,305;455,270;595,270])
add_line([sys,'/','A//C'],[430,350;485,350])
add_line([sys,'/','A//C'],[430,350;470,350;470,285;485,285])
add_line([sys,'/','A//C'],[630,275;815,275])
add_line([sys,'/','A//C'],[450,230;480,230])
add_line([sys,'/','A//C'],[450,160;480,160])
add_line([sys,'/','A//C'],[575,225;590,225;590,265;815,265])
add_line([sys,'/','A//C'],[660,200;1015,200])
add_line([sys,'/','A//C'],[940,410;940,415;1015,425])
add_line([sys,'/','A//C'],[370,495;595,495])
set_param([sys,'/','A//C'],...
    'Mask Display',' AC velocity (z,x)\nTime          \n AC position (x,y,z)')

```

% Finished composite block 'A//C'.

```

set_param([sys,'/','A//C'],...
    'position',[150,154,280,201])

add_block('built-in/To Workspace',[sys,'/','launchflag'])
set_param([sys,'/','launchflag'],...
    'mat-name','launchflag'...
    'buffer','1000000000'...
    'position',[1650,635,1755,655])

add_block('built-in/Clock',[sys,'/','Clock'])
set_param([sys,'/','Clock'],...
    'position',[60,400,80,420])

add_block('built-in/To Workspace',[sys,'/','time'])
set_param([sys,'/','time'],...
    'mat-name','time'...
    'buffer','1000000'...

```

```

'position',[155,402.205,418])

% Subsystem 'Missile_Control'.

new_system([sys,/, 'Missile_Control'])
set_param([sys,/, 'Missile_Control'], 'Location', [-13,391,1105,556])

add_block('built-in/Inport',[sys,/, ['Missile_Control/Missile ',13,'position',13,'(x,y,z)']]
set_param([sys,/, ['Missile_Control/Missile ',13,'position',13,'(x,y,z)']],...
'Port','3',...
'position',[105,155,125,175])

add_block('built-in/Inport',[sys,/, 'Missile_Control/mrange'])
set_param([sys,/, 'Missile_Control/mrange'],...
'Port','2',...
'position',[305,50,325,70])

add_block('built-in/Product',[sys,/, 'Missile_Control/m3'])
set_param([sys,/, 'Missile_Control/m3'],...
'position',[385,135,410,155])

add_block('built-in/Fcn',[sys,/, 'Missile_Control/Fcn11'])
set_param([sys,/, 'Missile_Control/Fcn11'],...
'Expr','(1/u[1])',...
'position',[520,80,560,100])

add_block('built-in/MATLAB Fcn',[sys,/, 'Missile_Control/testnan.m'])
set_param([sys,/, 'Missile_Control/testnan.m'],...
'MATLAB Fcn','testnan',...
'position',[590,75,640,105])

add_block('built-in/Sum',[sys,/, 'Missile_Control/Sum4'])
set_param([sys,/, 'Missile_Control/Sum4'],...
'inputs','+-+',...
'position',[335,142,355,178])

add_block('built-in/Mux',[sys,/, 'Missile_Control/Mux'])
set_param([sys,/, 'Missile_Control/Mux'],...
'inputs','2',...
'position',[155,114,185,181])

add_block('built-in/MATLAB Fcn',[sys,/, 'Missile_Control/testzero.m'])
set_param([sys,/, 'Missile_Control/testzero.m'],...
'MATLAB Fcn','testzero',...
'position',[415,75,465,105])

add_block('built-in/Gain',[sys,/, 'Missile_Control/Gain1'])
set_param([sys,/, 'Missile_Control/Gain1'],...
'Gain','.5',...
'position',[425,135,445,155])

add_block('built-in/Transfer Fcn',[sys,/, ['Missile_Control/Transfer ',13,'Fcn9']]
set_param([sys,/, ['Missile_Control/Transfer ',13,'Fcn9']],...
'Numerator','[1 2 1]',...

```

```

'Denominator',[.0999 .632 1]',...
'position',[460,126,580,164])

add_block('built-in/Inport',[sys,/, 'Missile_Control/AC position (x,y,z)'])
set_param([sys,/, 'Missile_Control/AC position (x,y,z)'],...
'position',[60,120,80,140])

add_block('built-in/Product',[sys,/, 'Missile_Control/mn4'])
set_param([sys,/, 'Missile_Control/mn4'],...
'position',[270,250,295,270])

add_block('built-in/White Noise',[sys,/, 'Missile_Control/White Noise',13,'4'])
set_param([sys,/, 'Missile_Control/White Noise',13,'4'],...
'Seed', 'noiseseed(4)',...
'position',[150,245,170,265])

% Subsystem ['Missile_Control/hold4',13,'sample=.1'].

new_system([sys,/, 'Missile_Control/hold4',13,'sample=.1'])
set_param([sys,/, 'Missile_Control/hold4',13,'sample=.1'], 'Location',[511,151,915,322])

add_block('built-in/Outport',[sys,/, 'Missile_Control/hold4',13,'sample=.1/output'])
set_param([sys,/, 'Missile_Control/hold4',13,'sample=.1/output'],...
'position',[345,45,365,65])

add_block('built-in/Inport',[sys,/, 'Missile_Control/hold4',13,'sample=.1/input'])
set_param([sys,/, 'Missile_Control/hold4',13,'sample=.1/input'],...
'position',[25,35,45,55])

add_block('built-in/Unit Delay',[sys,/, 'Missile_Control/hold4',13,'sample=.1/Unit Delay'])
set_param([sys,/, 'Missile_Control/hold4',13,'sample=.1/Unit Delay'],...
'Sample time','Ts',...
'position',[90,93,140,117])

add_block('built-in/Sum',[sys,/, 'Missile_Control/hold4',13,'sample=.1/Sum'])
set_param([sys,/, 'Missile_Control/hold4',13,'sample=.1/Sum'],...
'inputs','+',...
'position',[190,37,210,68])

add_block('built-in/Integrator',[sys,/, 'Missile_Control/hold4',13,'sample=.1/Integrator'])
set_param([sys,/, 'Missile_Control/hold4',13,'sample=.1/Integrator'],...
'position',[235,42,260,68])

add_block('built-in/Gain',[sys,/, 'Missile_Control/hold4',13,'sample=.1/Gain'])
set_param([sys,/, 'Missile_Control/hold4',13,'sample=.1/Gain'],...
'Gain','1/Ts',...
'position',[285,33,325,77])

add_block('built-in/Zero-Order Hold',[sys,/, 'Missile_Control/hold4',13,'sample=.1/Zero-Order',13,'Hold'])
set_param([sys,/, 'Missile_Control/hold4',13,'sample=.1/Zero-Order',13,'Hold'],...
'Sample time','Ts',...
'position',[100,29,135,61])
add_line([sys,/, 'Missile_Control/hold4',13,'sample=.1'],[50,45;95,45])
add_line([sys,/, 'Missile_Control/hold4',13,'sample=.1'],[65,45;65,105;85,105])

```

```

add_line([sys,'/','Missile_Control/hold4',13,'sample=.1'],[140,45;185,45])
add_line([sys,'/','Missile_Control/hold4',13,'sample=.1'],[145,105;165,105;165,60;185,60])
add_line([sys,'/','Missile_Control/hold4',13,'sample=.1'],[215,55;230,55])
add_line([sys,'/','Missile_Control/hold4',13,'sample=.1'],[265,55;280,55])
add_line([sys,'/','Missile_Control/hold4',13,'sample=.1'],[330,55;340,55])
set_param([sys,'/','Missile_Control/hold4',13,'sample=.1'],...
    'Mask Display','plot(0,0,100,100,[90,70,50,30,10],[60,40,80,30,20])',...
    'Mask Type','First-Order Hold',...
    'Mask Dialogue','First-Order Hold!Sample Time:')
set_param([sys,'/','Missile_Control/hold4',13,'sample=.1'],...
    'Mask Translate','Ts=@ 1;',...
    'Mask Help','Implements a First-Order sample-and-hold latch operating at the sampling
interval you specify.',...
    'Mask Entries','.1V')

```

```

% Finished composite block ['Missile_Control/hold4',13,'sample=.1'].

```

```

set_param([sys,'/','Missile_Control/hold4',13,'sample=.1'],...
    'position',[200,239,235,271])

```

```

add_block('built-in/MATLAB Fcn',[sys,'/','Missile_Control/Relative Angle',13,'between LOS
and',13,'Bearing',13,'relanglr.m'])
set_param([sys,'/','Missile_Control/Relative Angle',13,'between LOS and',13,'Bearing',13,'relanglr.m'],...
    'MATLAB Fcn','relanglr',...
    'Output Width','1',...
    'position',[225,135,275,165])

```

```

add_block('built-in/Sum',[sys,'/','Missile_Control/sum5n'])
set_param([sys,'/','Missile_Control/sum5n'],...
    'position',[905,138,930,162])

```

```

add_block('built-in/Integrator',[sys,'/','Missile_Control/Integr',13,'ator8'])
set_param([sys,'/','Missile_Control/Integr',13,'ator8'],...
    'position',[950,135,970,155])

```

```

add_block('built-in/Integrator',[sys,'/','Missile_Control/Integr',13,'ator7'])
set_param([sys,'/','Missile_Control/Integr',13,'ator7'],...
    'position',[990,135,1010,155])

```

```

add_block('built-in/Product',[sys,'/','Missile_Control/m10'])
set_param([sys,'/','Missile_Control/m10'],...
    'position',[1040,130,1065,150])

```

```

add_block('built-in/MATLAB Fcn',[sys,'/','Missile_Control/testnan.m_'])
set_param([sys,'/','Missile_Control/testnan.m_'],...
    'MATLAB Fcn','testnan',...
    'position',[1085,125,1135,155])

```

```

add_block('built-in/Constant',[sys,'/','Missile_Control/MThrust_Duration'])
set_param([sys,'/','Missile_Control/MThrust_Duration'],...
    'Value','MThrust_Duration',...
    'position',[885,296,1005,314])

```

```

add_block('built-in/Constant',[sys,'/','Missile_Control/shottime'])

```

```

set_param([sys,'/','Missile_Control/shottime'],...
          'Value','shottime',...
          'position',[915,267,1005,283])

add_block('built-in/Inport',[sys,'/','Missile_Control/in_4'])
set_param([sys,'/','Missile_Control/in_4'],...
          'Port','4',...
          'position',[1045,235,1065,255])

add_block('built-in/Mux',[sys,'/','Missile_Control/Mux5'])
set_param([sys,'/','Missile_Control/Mux5'],...
          'inputs','3',...
          'position',[1095,230,1130,320])

add_block('built-in/MATLAB Fcn',[sys,'/','Missile_Control/missilego.m'])
set_param([sys,'/','Missile_Control/missilego.m'],...
          'MATLAB Fcn','missilego',...
          'Output Width','1',...
          'position',[1185,260,1235,290])

add_block('built-in/To Workspace',[sys,'/','Missile_Control/test'])
set_param([sys,'/','Missile_Control/test'],...
          'mat-name','missilevel',...
          'buffer','1000000000',...
          'position',[1295,307,1375,323])

add_block('built-in/Product',[sys,'/','Missile_Control/m17'])
set_param([sys,'/','Missile_Control/m17'],...
          'position',[1320,195,1345,215])

add_block('built-in/Integrator',[sys,'/','Missile_Control/Integrator3'])
set_param([sys,'/','Missile_Control/Integrator3'],...
          'position',[1385,195,1405,215])

add_block('built-in/Integrator',[sys,'/','Missile_Control/Integrator2'])
set_param([sys,'/','Missile_Control/Integrator2'],...
          'position',[1385,135,1405,155])

add_block('built-in/Product',[sys,'/','Missile_Control/m18'])
set_param([sys,'/','Missile_Control/m18'],...
          'position',[1320,135,1345,155])

add_block('built-in/Fcn',[sys,'/','Missile_Control/Fcn2'])
set_param([sys,'/','Missile_Control/Fcn2'],...
          'position',[1200,130,1285,150])

add_block('built-in/Fcn',[sys,'/','Missile_Control/Fcn3'])
set_param([sys,'/','Missile_Control/Fcn3'],...
          'Expr','cos(u[1])',...
          'position',[1205,198,1290,222])

add_block('built-in/Outport',[sys,'/','Missile_Control/sin pos'])
set_param([sys,'/','Missile_Control/sin pos'],...
          'position',[1465,140,1485,160])

```



```

add_block('built-in/Outport',[sys,/, 'Missile_Control/cos pos'])
set_param([sys,/, 'Missile_Control/cos pos'],...
    'Port',2,...
    'position',[1465,190,1485,210])

add_block('built-in/Product',[sys,/, 'Missile_Control/mn5'])
set_param([sys,/, 'Missile_Control/mn5'],...
    'inputs',3,...
    'position',[825,207,850,263])

add_block('built-in/Constant',[sys,/, ['Missile_Control/MThrustN Standard ',13,'Deviation']])
set_param([sys,/, ['Missile_Control/MThrustN Standard ',13,'Deviation']],...
    'Value','MThrustNstd',...
    'position',[620,247,710,263])

add_block('built-in/White Noise',[sys,/, 'Missile_Control/White Noise 5'])
set_param([sys,/, 'Missile_Control/White Noise 5'],...
    'Seed','noiseseed(5)',...
    'position',[745,220,765,240])

add_block('built-in/Transfer Fcn',[sys,/, ['Missile_Control/Transfer ',13,'Fcn11']])
set_param([sys,/, ['Missile_Control/Transfer ',13,'Fcn11']],...
    'Denominator',[.00694444 .05 1],...
    'position',[655,123,800,167])

add_block('built-in/Transfer Fcn',[sys,/, ['Missile_Control/Transfer ',13,'Fcn10']])
set_param([sys,/, ['Missile_Control/Transfer ',13,'Fcn10']],...
    'Numerator',[2 1],...
    'Denominator',[1 0],...
    'position',[595,127,635,163])

add_block('built-in/Constant',[sys,/, 'Missile_Control/Acquire Std Dev'])
set_param([sys,/, 'Missile_Control/Acquire Std Dev'],...
    'Value','AcquireNstd',...
    'position',[140,323,230,347])

add_block('built-in/Note',[sys,/, 'Missile_Control/BLOCK: Missile_Control'])
set_param([sys,/, 'Missile_Control/BLOCK: Missile_Control'],...
    'position',[635,405,640,410])
add_line([sys,/, 'Missile_Control'],[1240,275;1297,275;1297,200;1315,200])
add_line([sys,/, 'Missile_Control'],[1297,200;1297,150;1315,150])
add_line([sys,/, 'Missile_Control'],[1135,275;1180,275])
add_line([sys,/, 'Missile_Control'],[1010,305;1090,305])
add_line([sys,/, 'Missile_Control'],[1010,275;1090,275])
add_line([sys,/, 'Missile_Control'],[1240,275;1257,275;1257,315;1290,315])
add_line([sys,/, 'Missile_Control'],[300,260;320,260;330,170])
add_line([sys,/, 'Missile_Control'],[240,255;265,255])
add_line([sys,/, 'Missile_Control'],[175,255;195,255])
add_line([sys,/, 'Missile_Control'],[235,335;253,335;253,265;265,265])
add_line([sys,/, 'Missile_Control'],[805,145;900,145])
add_line([sys,/, 'Missile_Control'],[770,230;787,230;787,235;820,235])
add_line([sys,/, 'Missile_Control'],[715,255;820,255])
add_line([sys,/, 'Missile_Control'],[330,60;370,60;380,140])
add_line([sys,/, 'Missile_Control'],[370,127;370,90;410,90])
add_line([sys,/, 'Missile_Control'],[470,90;515,90])

```

```

add_line([sys,'/','Missile_Control'],[935,150:945,145])
add_line([sys,'/','Missile_Control'],[280,150:330,150])
add_line([sys,'/','Missile_Control'],[645,90:1017,90;1017,135;1035,135])
add_line([sys,'/','Missile_Control'],[565,90:585,90])
add_line([sys,'/','Missile_Control'],[1140,140;1195,140])
add_line([sys,'/','Missile_Control'],[1070,140;1080,140])
add_line([sys,'/','Missile_Control'],[1350,205;1380,205])
add_line([sys,'/','Missile_Control'],[1295,210;1315,210])
add_line([sys,'/','Missile_Control'],[1290,140;1315,140])
add_line([sys,'/','Missile_Control'],[1350,145;1380,145])
add_line([sys,'/','Missile_Control'],[450,145;455,145])
add_line([sys,'/','Missile_Control'],[415,145;420,145])
add_line([sys,'/','Missile_Control'],[585,145;590,145])
add_line([sys,'/','Missile_Control'],[640,145;650,145])
add_line([sys,'/','Missile_Control'],[1015,145;1035,145])
add_line([sys,'/','Missile_Control'],[975,145;985,145])
add_line([sys,'/','Missile_Control'],[360,160;380,150])
add_line([sys,'/','Missile_Control'],[190,150;220,150])
add_line([sys,'/','Missile_Control'],[85,130;150,130])
add_line([sys,'/','Missile_Control'],[1410,145;1422,145;1460,150])
add_line([sys,'/','Missile_Control'],[130,165;150,165])
add_line([sys,'/','Missile_Control'],[1410,205;1422,205;1460,200])
add_line([sys,'/','Missile_Control'],[1070,245;1090,245])
add_line([sys,'/','Missile_Control'],[1140,140;1165,140;1165,200;310,200;310,160;330,160])
add_line([sys,'/','Missile_Control'],[855,235;865,235;865,155;900,155])
add_line([sys,'/','Missile_Control'],[805,145;810,145;820,215])
add_line([sys,'/','Missile_Control'],[1165,200;1165,210;1200,210])
set_param([sys,'/','Missile_Control'],...
    'Mask Display','AC position (x,y,z)    \nMissile range    sin pos\nMissile (x,y,z)
\nTime    cos pos')

```

```

% Finished composite block 'Missile_Control'.

```

```

set_param([sys,'/','Missile_Control'],...
    'position',[380,183,530,242])

```

```

% Subsystem 'Missile_Range'.

```

```

new_system([sys,'/','Missile_Range'])
set_param([sys,'/','Missile_Range'],'Location',[35,230,880,506])

```

```

add_block('built-in/Outport',[sys,'/','Missile_Range/Missile Range'])
set_param([sys,'/','Missile_Range/Missile Range'],...
    'orientation',2,...
    'position',[80,95,100,115])

```

```

add_block('built-in/To Workspace',[sys,'/','Missile_Range/mrange'])
set_param([sys,'/','Missile_Range/mrange'],...
    'orientation',2,...
    'mat-name','mrange',...
    'buffer','1000000',...
    'position',[70,137,120,153])

```

```
add_block('built-in/Inport',[sys,/, 'Missile_Range/Missile Position (x,y,z)'])
set_param([sys,/, 'Missile_Range/Missile Position (x,y,z)'],...
    'orientation',2,...
    'position',[645,90,665,110])
```

```
add_block('built-in/Product',[sys,/, 'Missile_Range/m8'])
set_param([sys,/, 'Missile_Range/m8'],...
    'orientation',2,...
    'position',[340,125,365,145])
```

```
add_block('built-in/Product',[sys,/, 'Missile_Range/m7'])
set_param([sys,/, 'Missile_Range/m7'],...
    'orientation',2,...
    'position',[385,95,410,115])
```

```
add_block('built-in/Sum',[sys,/, 'Missile_Range/Sum3'])
set_param([sys,/, 'Missile_Range/Sum3'],...
    'orientation',2,...
    'inputs','+++',...
    'position',[270,87,290,123])
```

```
add_block('built-in/Product',[sys,/, 'Missile_Range/m6'])
set_param([sys,/, 'Missile_Range/m6'],...
    'orientation',2,...
    'position',[340,60,365,80])
```

```
add_block('built-in/Demux',[sys,/, 'Missile_Range/Demux7'])
set_param([sys,/, 'Missile_Range/Demux7'],...
    'orientation',2,...
    'outputs','3',...
    'position',[505,83,545,117])
```

```
add_block('built-in/Fcn',[sys,/, 'Missile_Range/Fcn10'])
set_param([sys,/, 'Missile_Range/Fcn10'],...
    'orientation',2,...
    'Expr','sqrt(u[1])',...
    'position',[145,91,230,119])
```

```
add_block('built-in/Note',[sys,/, 'Missile_Range/BLOCK: Missile_Range'])
set_param([sys,/, 'Missile_Range/BLOCK: Missile_Range'],...
    'position',[365,205,370,210])
add_line([sys,/, 'Missile_Range'],[500,110;462,110;462,130;370,130])
add_line([sys,/, 'Missile_Range'],[407,130;407,140;370,140])
add_line([sys,/, 'Missile_Range'],[500,90;452,90;452,65;370,65])
add_line([sys,/, 'Missile_Range'],[387,65;387,75;370,75])
add_line([sys,/, 'Missile_Range'],[500,100;415,100])
add_line([sys,/, 'Missile_Range'],[447,100;447,110;415,110])
add_line([sys,/, 'Missile_Range'],[265,105;235,105])
add_line([sys,/, 'Missile_Range'],[335,70;307,70;295,95])
add_line([sys,/, 'Missile_Range'],[380,105;295,105])
add_line([sys,/, 'Missile_Range'],[335,135;307,135;295,115])
add_line([sys,/, 'Missile_Range'],[140,105;135,105;125,145])
add_line([sys,/, 'Missile_Range'],[640,100;550,100])
add_line([sys,/, 'Missile_Range'],[140,105;105,105])
set_param([sys,/, 'Missile_Range'],...
```

```

add_block('built-in/Inport',[sys,/, 'Missilexyz/in_3'])
set_param([sys,/, 'Missilexyz/in_3'],...
    'Port','3',...
    'position',[495,355,515,375])

add_block('built-in/Product',[sys,/, 'Missilexyz/m11'])
set_param([sys,/, 'Missilexyz/m11'],...
    'position',[880,385,905,405])

add_block('built-in/Product',[sys,/, 'Missilexyz/m12'])
set_param([sys,/, 'Missilexyz/m12'],...
    'position',[905,305,930,325])

add_block('built-in/Product',[sys,/, 'Missilexyz/m13'])
set_param([sys,/, 'Missilexyz/m13'],...
    'position',[920,210,945,230])

add_block('built-in/Sum',[sys,/, 'Missilexyz/Sum7'])
set_param([sys,/, 'Missilexyz/Sum7'],...
    'position',[995,390,1015,410])

add_block('built-in/Product',[sys,/, 'Missilexyz/m16'])
set_param([sys,/, 'Missilexyz/m16'],...
    'position',[910,435,935,455])

add_block('built-in/MATLAB Fcn',[sys,/, 'Missilexyz/divplus.m(3)'])
set_param([sys,/, 'Missilexyz/divplus.m(3)'],...
    'MATLAB Fcn','divplus',...
    'Output Width','1',...
    'position',[535,200,585,230])

add_block('built-in/Sum',[sys,/, 'Missilexyz/Sum6'])
set_param([sys,/, 'Missilexyz/Sum6'],...
    'position',[1015,335,1035,355])

add_block('built-in/Product',[sys,/, 'Missilexyz/m15'])
set_param([sys,/, 'Missilexyz/m15'],...
    'position',[950,345,975,365])

add_block('built-in/To Workspace',[sys,/, 'Missilexyz/ym'])
set_param([sys,/, 'Missilexyz/ym'],...
    'mat-name','ym',...
    'buffer','1000000000',...
    'position',[1115,337,1165,353])

add_block('built-in/To Workspace',[sys,/, 'Missilexyz/zm'])
set_param([sys,/, 'Missilexyz/zm'],...
    'mat-name','zm',...
    'buffer','1000000000',...
    'position',[1125,392,1175,408])

add_block('built-in/Mux',[sys,/, 'Missilexyz/Mux19'])
set_param([sys,/, 'Missilexyz/Mux19'],...
    'orientation',3,...

```

```

        'inputs',3',...
        'position',[1052,45,1088,95])

add_block('built-in/Product',[sys,/, 'Missilexyz/m14'])
set_param([sys,/, 'Missilexyz/m14'],...
    'position',[925,265,950,285])

add_block('built-in/Sum',[sys,/, 'Missilexyz/Sum5'])
set_param([sys,/, 'Missilexyz/Sum5'],...
    'position',[985,235,1005,255])

add_block('built-in/To Workspace',[sys,/, 'Missilexyz/xm'])
set_param([sys,/, 'Missilexyz/xm'],...
    'mat-name','xm',...
    'buffer','1000000000',...
    'position',[1120,237,1170,253])

add_block('built-in/Outport',[sys,/, ['Missilexyz/Missile position',13,'(x,y,z)']]
set_param([sys,/, ['Missilexyz/Missile position',13,'(x,y,z)']],...
    'orientation',3,...
    'position',[1060,10,1080,30])

add_block('built-in/Inport',[sys,/, 'Missilexyz/in_2'])
set_param([sys,/, 'Missilexyz/in_2'],...
    'Port','2',...
    'position',[780,390,800,410])

add_block('built-in/Demux',[sys,/, 'Missilexyz/Demux4'])
set_param([sys,/, 'Missilexyz/Demux4'],...
    'outputs','3',...
    'position',[95,112,135,168])

add_block('built-in/Product',[sys,/, 'Missilexyz/m2'])
set_param([sys,/, 'Missilexyz/m2'],...
    'position',[245,285,270,305])

add_block('built-in/Inport',[sys,/, ['Missilexyz/AC position',13,'(x,y,z)']]
set_param([sys,/, ['Missilexyz/AC position',13,'(x,y,z)']],...
    'position',[40,130,60,150])

add_block('built-in/Product',[sys,/, 'Missilexyz/m1'])
set_param([sys,/, 'Missilexyz/m1'],...
    'position',[205,205,230,225])

add_block('built-in/Product',[sys,/, 'Missilexyz/m'])
set_param([sys,/, 'Missilexyz/m'],...
    'position',[205,260,230,280])

add_block('built-in/Note',[sys,/, 'Missilexyz/BLOCK: Missilexyz'])
set_param([sys,/, 'Missilexyz/BLOCK: Missilexyz'],...
    'position',[470,500,475,505])

add_block('built-in/Note',[sys,/, 'Missilexyz/alpha '])
set_param([sys,/, 'Missilexyz/alpha '],...
    'position',[612,195,617,200])

```

```

add_line([sys,/, 'Missilexyz'],[935,315;957,315;957,340;1010,340])
add_line([sys,/, 'Missilexyz'],[590,215;915,215])
add_line([sys,/, 'Missilexyz'],[905,215;895,215;895,270;920,270])
add_line([sys,/, 'Missilexyz'],[140,160;147,160;147,290;240,290])
add_line([sys,/, 'Missilexyz'],[147,270;147,300;240,300])
add_line([sys,/, 'Missilexyz'],[140,140;167,140;167,265;200,265])
add_line([sys,/, 'Missilexyz'],[140,120;185,120;185,210;200,210])
add_line([sys,/, 'Missilexyz'],[1020,400;1120,400])
add_line([sys,/, 'Missilexyz'],[1020,400;1080,400;1080,100])
add_line([sys,/, 'Missilexyz'],[1010,245;1115,245])
add_line([sys,/, 'Missilexyz'],[1010,245;1060,245;1060,100])
add_line([sys,/, 'Missilexyz'],[1040,345;1110,345])
add_line([sys,/, 'Missilexyz'],[1040,345;1070,345;1070,100])
add_line([sys,/, 'Missilexyz'],[235,215;287,215;287,260;320,260])
add_line([sys,/, 'Missilexyz'],[275,295;287,295;287,280;320,280])
add_line([sys,/, 'Missilexyz'],[430,270;530,270])
add_line([sys,/, 'Missilexyz'],[430,270;467,270;467,320;650,320])
add_line([sys,/, 'Missilexyz'],[430,270;427,270;427,220;440,220])
add_line([sys,/, 'Missilexyz'],[350,270;355,270])
add_line([sys,/, 'Missilexyz'],[910,395;990,395])
add_line([sys,/, 'Missilexyz'],[940,445;960,445;960,405;990,405])
add_line([sys,/, 'Missilexyz'],[980,355;990,355;990,350;1010,350])
add_line([sys,/, 'Missilexyz'],[955,275;970,275;980,250])
add_line([sys,/, 'Missilexyz'],[950,220;967,220;967,240;980,240])
add_line([sys,/, 'Missilexyz'],[650,265;882,265;882,310;900,310])
add_line([sys,/, 'Missilexyz'],[690,315;710,315])
add_line([sys,/, 'Missilexyz'],[570,265;590,265])
add_line([sys,/, 'Missilexyz'],[480,215;530,215])
add_line([sys,/, 'Missilexyz'],[65,140;90,140])
add_line([sys,/, 'Missilexyz'],[1070,40;1070,35])
add_line([sys,/, 'Missilexyz'],[520,365;650,365;650,450;905,450])
add_line([sys,/, 'Missilexyz'],[520,365;840,365;840,360;945,360])
add_line([sys,/, 'Missilexyz'],[840,365;840,280;920,280])
add_line([sys,/, 'Missilexyz'],[770,315;815,315;815,390;875,390])
add_line([sys,/, 'Missilexyz'],[815,390;815,440;905,440])
add_line([sys,/, 'Missilexyz'],[147,300;155,300;155,325;510,325;510,305;650,305])
add_line([sys,/, 'Missilexyz'],[235,270;320,270])
add_line([sys,/, 'Missilexyz'],[185,210;185,220;200,220])
add_line([sys,/, 'Missilexyz'],[175,265;175,275;200,275])
add_line([sys,/, 'Missilexyz'],[167,240;455,240;455,255;530,255])
add_line([sys,/, 'Missilexyz'],[185,190;430,190;440,205])
add_line([sys,/, 'Missilexyz'],[805,400;875,400])
add_line([sys,/, 'Missilexyz'],[855,400;855,320;900,320])
add_line([sys,/, 'Missilexyz'],[855,320;855,225;915,225])
add_line([sys,/, 'Missilexyz'],[880,265;880,350;945,350])
set_param([sys,/, 'Missilexyz'],...
    'Mask Display','AC position (x,y,z)    \nsin pos    Missile (x,y,z)\ncos pos
)

% Finished composite block 'Missilexyz'.

set_param([sys,/, 'Missilexyz'],...
    'position',[620,39,770,91])

```

```

% Subsystem 'Relative_angles_and_range'.

new_system([sys, '/', 'Relative_angles_and_range'])
set_param([sys, '/', 'Relative_angles_and_range'], 'Location', [45, 102, 620, 460])

add_block('built-in/To Workspace',[sys, '/', 'Relative_angles_and_range/A/C - missile slant range'])
set_param([sys, '/', 'Relative_angles_and_range/A/C - missile slant range'],...
    'mat-name','amslanrange',...
    'buffer','1000000000',...
    'position',[425, 213, 545, 227])

add_block('built-in/Outport',[sys, '/', 'Relative_angles_and_range/Missile phi'])
set_param([sys, '/', 'Relative_angles_and_range/Missile phi'],...
    'position',[455, 85, 475, 105])

add_block('built-in/Inport',[sys, '/', 'Relative_angles_and_range/AC position (x,y,z)'])
set_param([sys, '/', 'Relative_angles_and_range/AC position (x,y,z)],...
    'Port','2',...
    'position',[65, 140, 85, 160])

add_block('built-in/Inport',[sys, '/', 'Relative_angles_and_range/Missile Position (x,y,z)'])
set_param([sys, '/', 'Relative_angles_and_range/Missile Position (x,y,z)],...
    'position',[65, 105, 85, 125])

add_block('built-in/Mux',[sys, '/', 'Relative_angles_and_range/Mux6'])
set_param([sys, '/', 'Relative_angles_and_range/Mux6'],...
    'inputs','2',...
    'position',[140, 99, 170, 166])

add_block('built-in/MATLAB Fcn',[sys, '/', ['Relative_angles_and_range/Relative Angle', 13, 'between
A/C', 13, 'and missile', 13, 'acmangle.m']])
set_param([sys, '/', ['Relative_angles_and_range/Relative Angle', 13, 'between A/C', 13, 'and
missile', 13, 'acmangle.m']],...
    'MATLAB Fcn','acmangle',...
    'Output Width','3',...
    'position',[200, 120, 250, 150])

add_block('built-in/Demux',[sys, '/', 'Relative_angles_and_range/Demux'])
set_param([sys, '/', 'Relative_angles_and_range/Demux'],...
    'outputs','3',...
    'position',[280, 119, 320, 151])

add_block('built-in/Outport',[sys, '/', 'Relative_angles_and_range/Missile theta'])
set_param([sys, '/', 'Relative_angles_and_range/Missile theta'],...
    'Port','2',...
    'position',[485, 125, 505, 145])

add_block('built-in/Outport',[sys, '/', 'Relative_angles_and_range/Missile Range'])
set_param([sys, '/', 'Relative_angles_and_range/Missile Range'],...
    'Port','3',...
    'position',[420, 250, 440, 270])

add_block('built-in/To Workspace',[sys, '/', ['Relative_angles_and_range/Theta angle between ', 13, ' A/C and
missile']])

```

```

set_param([sys,/,['Relative_angles_and_range/Theta angle between ',13,' A//C and missile']],...
    'mat-name','acmtheta_end',...
    'buffer','1000000000',...
    'position',[455,165,580,185])

add_block('built-in/To Workspace',[sys,/,['Relative_angles_and_range/Phi angle between ',13,'A//C and
missile ']])
set_param([sys,/,['Relative_angles_and_range/Phi angle between ',13,'A//C and missile ']],...
    'mat-name','acmphi_end',...
    'buffer','1000000000',...
    'position',[400,41,480,59])

add_block('built-in/Note',[sys,/, 'Relative_angles_and_range/BLOCK: Relative_angles_and_range'])
set_param([sys,/, 'Relative_angles_and_range/BLOCK: Relative_angles_and_range'],...
    'position',[220,300,225,305])
add_line([sys,/, 'Relative_angles_and_range',[325,135;405,135;405,175;450,175])
add_line([sys,/, 'Relative_angles_and_range',[325,145;365,145;365,220;420,220])
add_line([sys,/, 'Relative_angles_and_range',[325,125;365,125;365,50;395,50])
add_line([sys,/, 'Relative_angles_and_range',[255,135;275,135])
add_line([sys,/, 'Relative_angles_and_range',[175,135;195,135])
add_line([sys,/, 'Relative_angles_and_range',[90,115;135,115])
add_line([sys,/, 'Relative_angles_and_range',[325,125;365,125;365,95;450,95])
add_line([sys,/, 'Relative_angles_and_range',[325,135;480,135])
add_line([sys,/, 'Relative_angles_and_range',[325,145;365,145;365,260;415,260])
add_line([sys,/, 'Relative_angles_and_range',[90,150;135,150])
set_param([sys,/, 'Relative_angles_and_range'],...
    'Mask Display,' Missile Missile Phi\nPosition (x,y,z) \n
Missile Theta\n AC position Missile \n (x,y,z) Range (rel)

% Finished composite block 'Relative_angles_and_range'.

set_param([sys,/, 'Relative_angles_and_range'],...
    'position',[625,501,790,559])

% Subsystem 'Launch_data'.

new_system([sys,/, 'Launch_data'])
set_param([sys,/, 'Launch_data'], 'Location',[255,355,995,690])

add_block('built-in/Look Up Table',[sys,/, ['Launch_data/Look-up',13,'IN:Launch theta',13,'OUT:Launch
Phi']])
set_param([sys,/, ['Launch_data/Look-up',13,'IN:Launch theta',13,'OUT:Launch Phi']],...
    'orientation',2,...
    'Input_Values','theta_launch_lu',...
    'Output_Values','phi_launch_lu',...
    'position',[230,128,260,152])

add_block('built-in/Product',[sys,/, 'Launch_data/m21'])
set_param([sys,/, 'Launch_data/m21'],...
    'orientation',2,...
    'position',[390,130,415,150])

add_block('built-in/Constant',[sys,/, 'Launch_data/57.3'])

```



```

set_param([sys,'','Launch_data/57.3'],...
          'orientation',2,...
          'Value','57.3',...
          'position',[450,140,490,160])

add_block('built-in/Sum',[sys,'','Launch_data/Sum24'])
set_param([sys,'','Launch_data/Sum24'],...
          'orientation',2,...
          'position',[505,123,530,147])

add_block('built-in/Inport',[sys,'','Launch_data/Missile theta'])
set_param([sys,'','Launch_data/Missile theta'],...
          'orientation',2,...
          'position',[755,235,775,255])

add_block('built-in/Product',[sys,'','Launch_data/m23'])
set_param([sys,'','Launch_data/m23'],...
          'orientation',2,...
          'position',[585,130,610,150])

add_block('built-in/Constant',[sys,'','Launch_data/trackerstd'])
set_param([sys,'','Launch_data/trackerstd'],...
          'orientation',2,...
          'Value','trackerstd',...
          'position',[805,134,870,156])

add_block('built-in/Inport',[sys,'','Launch_data/Missile phi'])
set_param([sys,'','Launch_data/Missile phi'],...
          'orientation',2,...
          'Port','2',...
          'position',[515,250,535,270])

add_block('built-in/Look Up Table',[sys,'','[Launch_data/Look-up',13,'IN: Missile
Theta',13,'OUT:Launch',13,' theta']])
set_param([sys,'','[Launch_data/Look-up',13,'IN: Missile Theta',13,'OUT:Launch',13,' theta']],...
          'orientation',2,...
          'Input_Values','theta_missile_lu',...
          'Output_Values','theta_launch_lu',...
          'position',[335,128,365,152])

add_block('built-in/Outport',[sys,'','Launch_data/Launch data'])
set_param([sys,'','Launch_data/Launch data'],...
          'orientation',2,...
          'position',[50,220,70,240])

add_block('built-in/Mux',[sys,'','Launch_data/Mux14'])
set_param([sys,'','Launch_data/Mux14'],...
          'orientation',2,...
          'inputs','5',...
          'position',[120,196,150,264])

add_block('built-in/Look Up Table',[sys,'','[Launch_data/Look-up',13,'IN:Missile Theta',13,'OUT: Time-to-
target']])
set_param([sys,'','[Launch_data/Look-up',13,'IN:Missile Theta',13,'OUT: Time-to-target']],...
          'orientation',2,...

```

```

        'Input_Values','theta_missile_lu',...
        'Output_Values','time_lu',...
        'position',[605,168,635,192])

add_block('built-in/White Noise',[sys,'/','Launch_data/White Noise',13,'6'])
set_param([sys,'/','Launch_data/White Noise',13,'6'],...
    'orientation',2,...
    'Seed',noiseseed(6),...
    'position',[775,70,795,90])

% Subsystem ['Launch_data/hold5',13,'sample=.25'].

new_system([sys,'/','Launch_data/hold5',13,'sample=.25'])
set_param([sys,'/','Launch_data/hold5',13,'sample=.25'],'Location',[511,151,915,322])

add_block('built-in/Zero-Order Hold',[sys,'/','Launch_data/hold5',13,'sample=.25/Zero-Order',13,'Hold'])
set_param([sys,'/','Launch_data/hold5',13,'sample=.25/Zero-Order',13,'Hold'],...
    'Sample time','Ts',...
    'position',[100,29,135,61])

add_block('built-in/Gain',[sys,'/','Launch_data/hold5',13,'sample=.25/Gain'])
set_param([sys,'/','Launch_data/hold5',13,'sample=.25/Gain'],...
    'Gain','1/Ts',...
    'position',[285,33,325,77])

add_block('built-in/Integrator',[sys,'/','Launch_data/hold5',13,'sample=.25/Integrator'])
set_param([sys,'/','Launch_data/hold5',13,'sample=.25/Integrator'],...
    'position',[235,42,260,68])

add_block('built-in/Sum',[sys,'/','Launch_data/hold5',13,'sample=.25/Sum'])
set_param([sys,'/','Launch_data/hold5',13,'sample=.25/Sum'],...
    'inputs','+',...
    'position',[190,37,210,68])

add_block('built-in/Unit Delay',[sys,'/','Launch_data/hold5',13,'sample=.25/Unit Delay'])
set_param([sys,'/','Launch_data/hold5',13,'sample=.25/Unit Delay'],...
    'Sample time','Ts',...
    'position',[90,93,140,117])

add_block('built-in/Inport',[sys,'/','Launch_data/hold5',13,'sample=.25/input'])
set_param([sys,'/','Launch_data/hold5',13,'sample=.25/input'],...
    'position',[25,35,45,55])

add_block('built-in/Output',[sys,'/','Launch_data/hold5',13,'sample=.25/output'])
set_param([sys,'/','Launch_data/hold5',13,'sample=.25/output'],...
    'position',[345,45,365,65])
add_line([sys,'/','Launch_data/hold5',13,'sample=.25'],[330,55;340,55])
add_line([sys,'/','Launch_data/hold5',13,'sample=.25'],[265,55;280,55])
add_line([sys,'/','Launch_data/hold5',13,'sample=.25'],[215,55;230,55])
add_line([sys,'/','Launch_data/hold5',13,'sample=.25'],[145,105;165,105;165,60;185,60])
add_line([sys,'/','Launch_data/hold5',13,'sample=.25'],[140,45;185,45])
add_line([sys,'/','Launch_data/hold5',13,'sample=.25'],[50,45;95,45])
add_line([sys,'/','Launch_data/hold5',13,'sample=.25'],[65,45;65,105;85,105])
set_param([sys,'/','Launch_data/hold5',13,'sample=.25'],...

```

```

'Mask Display','plot(0,0,100,100,[90,70,50,30,10],[60,40,80,30,20])',...
'Mask Type','First-Order Hold',...
'Mask Dialogue','First-Order Hold(Sample Time:)'
set_param([sys,'/','Launch_data/hold5',13,'sample=.25']),...
'Mask Translate','Ts=@ 1;',...
'Mask Help','Implements a First-Order sample-and-hold latch operating at the sampling
interval you specify.',...
'Mask Entries','.25V')

```

```

% Finished composite block ['Launch_data/hold5',13,'sample=.25'].

```

```

set_param([sys,'/','Launch_data/hold5',13,'sample=.25']),...
'orientation',2,...
'position',[695,64,730,96])

```

```

add_block('built-in/Note',[sys,'/','Launch_data/BLOCK: Launch_data'])
set_param([sys,'/','Launch_data/BLOCK: Launch_data'],...
'position',[255,310,260,315])

```

```

add_line([sys,'/','Launch_data'],[750,245;155,245])
add_line([sys,'/','Launch_data'],[685,245;685,180;640,180])
add_line([sys,'/','Launch_data'],[600,180;540,180;540,230;155,230])
add_line([sys,'/','Launch_data'],[560,245;560,130;535,130])
add_line([sys,'/','Launch_data'],[580,140;535,140])
add_line([sys,'/','Launch_data'],[500,135;420,135])
add_line([sys,'/','Launch_data'],[690,80;655,80;655,135;615,135])
add_line([sys,'/','Launch_data'],[800,145;615,145])
add_line([sys,'/','Launch_data'],[770,80;735,80])
add_line([sys,'/','Launch_data'],[330,140;295,140;295,215;155,215])
add_line([sys,'/','Launch_data'],[225,140;180,140;180,200;155,200])
add_line([sys,'/','Launch_data'],[445,150;435,145;420,145])
add_line([sys,'/','Launch_data'],[385,140;370,140])
add_line([sys,'/','Launch_data'],[330,140;265,140])
add_line([sys,'/','Launch_data'],[115,230;75,230])
add_line([sys,'/','Launch_data'],[510,260;155,260])
set_param([sys,'/','Launch_data'],...

```

```

'Mask Display','Missile theta \n Launch data\nMissile phi ')

```

```

% Finished composite block 'Launch_data'.

```

```

set_param([sys,'/','Launch_data'],...
'position',[885,693,985,742])

```

```

% Subsystem 'MissileVel_Seen_by_A/C'.

```

```

new_system([sys,'/','MissileVel_Seen_by_A/C'])
set_param([sys,'/','MissileVel_Seen_by_A/C'],'Location',[57,353,980,715])

```

```

add_block('built-in/Demux',[sys,'/','MissileVel_Seen_by_A/C/D5'])
set_param([sys,'/','MissileVel_Seen_by_A/C/D5'],...
'orientation',1,...
'outputs',2,...
'position',[785,70,825,110])

```

```
add_block('built-in/Inport',[sys,'','MissileVel_Seen_by_A//C/AC velocity (z,x)'])
set_param([sys,'','MissileVel_Seen_by_A//C/AC velocity (z,x)'],...
          'orientation',1,...
          'position',[795,35,815,55])
```

```
add_block('built-in/Derivative',[sys,'','MissileVel_Seen_by_A//C/dt2'])
set_param([sys,'','MissileVel_Seen_by_A//C/dt2'],...
          'orientation',2,...
          'position',[645,175,675,195])
```

```
add_block('built-in/Derivative',[sys,'','MissileVel_Seen_by_A//C/dt'])
set_param([sys,'','MissileVel_Seen_by_A//C/dt'],...
          'orientation',2,...
          'position',[745,220,775,240])
```

```
add_block('built-in/Sum',[sys,'','MissileVel_Seen_by_A//C/Sum20'])
set_param([sys,'','MissileVel_Seen_by_A//C/Sum20'],...
          'orientation',2,...
          'inputs','+-',...
          'position',[630,210,650,230])
```

```
add_block('built-in/Product',[sys,'','MissileVel_Seen_by_A//C/m27'])
set_param([sys,'','MissileVel_Seen_by_A//C/m27'],...
          'orientation',2,...
          'position',[570,205,595,225])
```

```
add_block('built-in/Product',[sys,'','MissileVel_Seen_by_A//C/m28'])
set_param([sys,'','MissileVel_Seen_by_A//C/m28'],...
          'orientation',2,...
          'position',[565,170,590,190])
```

```
add_block('built-in/Derivative',[sys,'','MissileVel_Seen_by_A//C/dt1'])
set_param([sys,'','MissileVel_Seen_by_A//C/dt1'],...
          'orientation',2,...
          'position',[670,145,700,165])
```

```
add_block('built-in/Demux',[sys,'','MissileVel_Seen_by_A//C/Demux6'])
set_param([sys,'','MissileVel_Seen_by_A//C/Demux6'],...
          'orientation',2,...
          'outputs','3',...
          'position',[830,243,870,297])
```

```
add_block('built-in/Sum',[sys,'','MissileVel_Seen_by_A//C/Sum22'])
set_param([sys,'','MissileVel_Seen_by_A//C/Sum22'],...
          'orientation',2,...
          'inputs','+-',...
          'position',[615,125,635,145])
```

```
add_block('built-in/Product',[sys,'','MissileVel_Seen_by_A//C/m26'])
set_param([sys,'','MissileVel_Seen_by_A//C/m26'],...
          'orientation',2,...
          'position',[555,125,580,145])
```

```
add_block('built-in/Sum',[sys,'','MissileVel_Seen_by_A//C/Sum21'])
```

```

set_param([sys,'/','MissileVel_Seen_by_A//C/Sum21'],...
    'orientation',2,...
    'inputs','+++',...
    'position',[490,127,510,163])

add_block('built-in/Outport',[sys,'/','MissileVel_Seen_by_A//C/Relative velocity ',13,'w// noise'])
set_param([sys,'/','MissileVel_Seen_by_A//C/Relative velocity ',13,'w// noise'],...
    'orientation',2,...
    'position',[60,165,80,185])

add_block('built-in/Fcn',[sys,'/','MissileVel_Seen_by_A//C/Fcn15'])
set_param([sys,'/','MissileVel_Seen_by_A//C/Fcn15'],...
    'orientation',2,...
    'Expr','sqrt(u[1])',...
    'position',[365,133,450,157])

add_block('built-in/Product',[sys,'/','MissileVel_Seen_by_A//C/m25'])
set_param([sys,'/','MissileVel_Seen_by_A//C/m25'],...
    'orientation',2,...
    'position',[200,190,225,210])

add_block('built-in/Constant',[sys,'/','MissileVel_Seen_by_A//C/missilelevelstd'])
set_param([sys,'/','MissileVel_Seen_by_A//C/missilelevelstd'],...
    'orientation',2,...
    'Value','missilelevelstd',...
    'position',[265,205,345,225])

add_block('built-in/Sum',[sys,'/','MissileVel_Seen_by_A//C/Sum25'])
set_param([sys,'/','MissileVel_Seen_by_A//C/Sum25'],...
    'orientation',2,...
    'position',[140,157,160,193])

add_block('built-in/Inport',[sys,'/','MissileVel_Seen_by_A//C/Missile position ',13,'(x,y,z)'])
set_param([sys,'/','MissileVel_Seen_by_A//C/Missile position ',13,'(x,y,z)'],...
    'orientation',2,...
    'Port','2',...
    'position',[930,260,950,280])

% Subsystem ['MissileVel_Seen_by_A//C/hold7',13,'sample: .25'].

new_system([sys,'/','MissileVel_Seen_by_A//C/hold7',13,'sample: .25'])
set_param([sys,'/','MissileVel_Seen_by_A//C/hold7',13,'sample: .25'],'Location',[511,151,915,322])

add_block('built-in/Zero-Order Hold',[sys,'/','MissileVel_Seen_by_A//C/hold7',13,'sample: .25/Zero-Order',13,'Hold'])
set_param([sys,'/','MissileVel_Seen_by_A//C/hold7',13,'sample: .25/Zero-Order',13,'Hold'],...
    'Sample time','Ts',...
    'position',[100,29,135,61])

add_block('built-in/Gain',[sys,'/','MissileVel_Seen_by_A//C/hold7',13,'sample: .25/Gain'])
set_param([sys,'/','MissileVel_Seen_by_A//C/hold7',13,'sample: .25/Gain'],...
    'Gain','1/Ts',...
    'position',[285,33,325,77])

```

```

add_block('built-in/Integrator',[sys,/,['MissileVel_Seen_by_A//C/hold7',13,'sample: .25/Integrator']])
set_param([sys,/,['MissileVel_Seen_by_A//C/hold7',13,'sample: .25/Integrator']],...
    'position',[235,42,260,68])

add_block('built-in/Sum',[sys,/,['MissileVel_Seen_by_A//C/hold7',13,'sample: .25/Sum']])
set_param([sys,/,['MissileVel_Seen_by_A//C/hold7',13,'sample: .25/Sum']],...
    'inputs','+',...
    'position',[190,37,210,68])

add_block('built-in/Unit Delay',[sys,/,['MissileVel_Seen_by_A//C/hold7',13,'sample: .25/Unit Delay']])
set_param([sys,/,['MissileVel_Seen_by_A//C/hold7',13,'sample: .25/Unit Delay']],...
    'Sample time','Ts',...
    'position',[90,93,140,117])

add_block('built-in/Inport',[sys,/,['MissileVel_Seen_by_A//C/hold7',13,'sample: .25/input']])
set_param([sys,/,['MissileVel_Seen_by_A//C/hold7',13,'sample: .25/input']],...
    'position',[25,35,45,55])

add_block('built-in/Outport',[sys,/,['MissileVel_Seen_by_A//C/hold7',13,'sample: .25/output']])
set_param([sys,/,['MissileVel_Seen_by_A//C/hold7',13,'sample: .25/output']],...
    'position',[345,45,365,65])
add_line([sys,/,['MissileVel_Seen_by_A//C/hold7',13,'sample: .25']], [330,55;340,55])
add_line([sys,/,['MissileVel_Seen_by_A//C/hold7',13,'sample: .25']], [265,55;280,55])
add_line([sys,/,['MissileVel_Seen_by_A//C/hold7',13,'sample: .25']], [215,55;230,55])
add_line([sys,/,['MissileVel_Seen_by_A//C/hold7',13,'sample: .25']], [145,105;165,105;165,60;185,60])
add_line([sys,/,['MissileVel_Seen_by_A//C/hold7',13,'sample: .25']], [140,45;185,45])
add_line([sys,/,['MissileVel_Seen_by_A//C/hold7',13,'sample: .25']], [50,45;95,45])
add_line([sys,/,['MissileVel_Seen_by_A//C/hold7',13,'sample: .25']], [65,45;65,105;85,105])
set_param([sys,/,['MissileVel_Seen_by_A//C/hold7',13,'sample: .25']],...
    'Mask Display','plot(0,0,100,100,[90,70,50,30,10],[60,40,80,30,20])',...
    'Mask Type','First-Order Hold',...
    'Mask Dialogue','First-Order Hold|Sample Time:')
set_param([sys,/,['MissileVel_Seen_by_A//C/hold7',13,'sample: .25']],...
    'Mask Translate','Ts=@1;',...
    'Mask Help','Implements a First-Order sample-and-hold latch operating at the sampling
interval you specify.',...
    'Mask Entries','.25V')

% Finished composite block ['MissileVel_Seen_by_A//C/hold7',13,'sample: .25'].

set_param([sys,/,['MissileVel_Seen_by_A//C/hold7',13,'sample: .25']],...
    'orientation',2,...
    'position',[365,179,400,211])

add_block('built-in/White Noise',[sys,/,['MissileVel_Seen_by_A//C/White Noise',13,'8']])
set_param([sys,/,['MissileVel_Seen_by_A//C/White Noise',13,'8']],...
    'orientation',2,...
    'Seed','noiseseed(8)',...
    'position',[445,185,465,205])

add_block('built-in/Note',[sys,/,['MissileVel_Seen_by_A//C/BLOCK: MissileVel_Seen_by_A//C']])
set_param([sys,/,['MissileVel_Seen_by_A//C/BLOCK: MissileVel_Seen_by_A//C']],...
    'position',[315,300,320,305])
add_line([sys,/,['MissileVel_Seen_by_A//C']], [825,250;792,250;792,230;780,230])

```

```

add_line([sys,/, 'MissileVel_Seen_by_A/C'],[825,270;717,270;717,185;680,185])
add_line([sys,/, 'MissileVel_Seen_by_A/C'],[825,290;722,290;722,155;705,155])
add_line([sys,/, 'MissileVel_Seen_by_A/C'],[360,145;302,145;302,165;165,165])
add_line([sys,/, 'MissileVel_Seen_by_A/C'],[195,200;187,200;187,185;165,185])
add_line([sys,/, 'MissileVel_Seen_by_A/C'],[360,195;230,195])
add_line([sys,/, 'MissileVel_Seen_by_A/C'],[260,215;257,205;230,205])
add_line([sys,/, 'MissileVel_Seen_by_A/C'],[440,195;405,195])
add_line([sys,/, 'MissileVel_Seen_by_A/C'],[640,185;595,185])
add_line([sys,/, 'MissileVel_Seen_by_A/C'],[630,185;630,175;595,175])
add_line([sys,/, 'MissileVel_Seen_by_A/C'],[485,145;455,145])
add_line([sys,/, 'MissileVel_Seen_by_A/C'],[625,220;625,210;600,210])
add_line([sys,/, 'MissileVel_Seen_by_A/C'],[625,220;600,220])
add_line([sys,/, 'MissileVel_Seen_by_A/C'],[740,230;732,225;655,225])
add_line([sys,/, 'MissileVel_Seen_by_A/C'],[665,155;640,140])
add_line([sys,/, 'MissileVel_Seen_by_A/C'],[815,115;815,215;655,215])
add_line([sys,/, 'MissileVel_Seen_by_A/C'],[795,115;795,130;640,130])
add_line([sys,/, 'MissileVel_Seen_by_A/C'],[560,180;547,180;547,145;515,145])
add_line([sys,/, 'MissileVel_Seen_by_A/C'],[565,215;525,215;515,155])
add_line([sys,/, 'MissileVel_Seen_by_A/C'],[550,135;515,135])
add_line([sys,/, 'MissileVel_Seen_by_A/C'],[610,135;585,130])
add_line([sys,/, 'MissileVel_Seen_by_A/C'],[610,135;585,140])
add_line([sys,/, 'MissileVel_Seen_by_A/C'],[805,60;805,65])
add_line([sys,/, 'MissileVel_Seen_by_A/C'],[135,175;85,175])
add_line([sys,/, 'MissileVel_Seen_by_A/C'],[925,270;875,270])
set_param([sys,/, 'MissileVel_Seen_by_A/C'],...
           'Mask Display','AC velocity (z,x) \n Relative Velocity\nMissile pos (x,y,z) ')

```

```

% Finished composite block 'MissileVel_Seen_by_A/C'.

```

```

set_param([sys,/, 'MissileVel_Seen_by_A/C'],...
           'position',[660,186,795,244])

```

```

% Subsystem 'Quad_data'.

```

```

new_system([sys,/, 'Quad_data'])
set_param([sys,/, 'Quad_data'], 'Location',[85,330,1125,630])

```

```

add_block('built-in/Constant',[sys,/, 'Quad_data/.95'])
set_param([sys,/, 'Quad_data/.95'],...
           'orientation',2,...
           'Value','.95',...
           'position',[160,91,185,109])

```

```

add_block('built-in/Product',[sys,/, 'Quad_data/mn7'])
set_param([sys,/, 'Quad_data/mn7'],...
           'orientation',2,...
           'position',[75,107,100,143])

```

```

add_block('built-in/MATLAB Fcn',[sys,/, 'Quad_data/divplus.m'])
set_param([sys,/, 'Quad_data/divplus.m'],...
           'orientation',2,...
           'MATLAB Fcn','divplus',...
           'Output Width','1',...

```

```

'position',[115,118,170,152])

add_block('built-in/Constant',[sys,'/','Quad_data/Avg det. dist.'])
set_param([sys,'/','Quad_data/Avg det. dist.'],...
'orientation',2,...
'Value','Average_detect_dist',...
'position',[235,61,370,79])

add_block('built-in/Mux',[sys,'/','Quad_data/Mux21'])
set_param([sys,'/','Quad_data/Mux21'],...
'orientation',2,...
'inputs',2,...
'position',[185,118,215,147])

add_block('built-in/Sum',[sys,'/','Quad_data/sum5n2'])
set_param([sys,'/','Quad_data/sum5n2'],...
'orientation',2,...
'inputs','+,...
'position',[275,93,300,117])

add_block('built-in/Product',[sys,'/','Quad_data/mn6'])
set_param([sys,'/','Quad_data/mn6'],...
'orientation',2,...
'inputs',3,...
'position',[330,102,355,138])

add_block('built-in/Outport',[sys,'/','Quad_data/out_1'])
set_param([sys,'/','Quad_data/out_1'],...
'orientation',2,...
'position',[25,115,45,135])

add_block('built-in/Fcn',[sys,'/','Quad_data/Fcn7'])
set_param([sys,'/','Quad_data/Fcn7'],...
'orientation',2,...
'Expr','cos(u[1])',...
'position',[505,99,575,121])

add_block('built-in/Constant',[sys,'/','Quad_data/deltaphi'])
set_param([sys,'/','Quad_data/deltaphi'],...
'orientation',2,...
'Value','((90/57.3)+acclimbangle-(93.12/57.3))',...
'position',[605,101,880,119])

add_block('built-in/Constant',[sys,'/','Quad_data/AC velocity'])
set_param([sys,'/','Quad_data/AC velocity'],...
'orientation',2,...
'Value','acvel',...
'position',[420,122,470,138])

add_block('built-in/Constant',[sys,'/','Quad_data/pi'])
set_param([sys,'/','Quad_data/pi'],...
'orientation',2,...
'Value','pi',...
'position',[730,161,755,179])

```



```

add_block('built-in/Sum',[sys,/,Quad_data/sum5n1'])
set_param([sys,/,Quad_data/sum5n1'],...
    'orientation',2,...
    'inputs','+',...
    'position',[680,153,705,177])

add_block('built-in/Demux',[sys,/,Quad_data/Demux2'])
set_param([sys,/,Quad_data/Demux2'],...
    'orientation',2,...
    'outputs',2,...
    'position',[780,141,820,174])

add_block('built-in/Switch',[sys,/,Quad_data/Switch ',13,'threshold=pi/2'])
set_param([sys,/,Quad_data/Switch ',13,'threshold=pi/2']),...
    'orientation',2,...
    'Threshold','90/57.3',...
    'position',[840,144,870,176])

add_block('built-in/Outport',[sys,/,Quad_data/quad_time_to_target'])
set_param([sys,/,Quad_data/quad_time_to_target'],...
    'orientation',2,...
    'Port',2,...
    'position',[740,200,760,220])

add_block('built-in/Fcn',[sys,/,Quad_data/Fcn5'])
set_param([sys,/,Quad_data/Fcn5'],...
    'orientation',2,...
    'Expr','cos(u[1])',...
    'position',[555,155,625,175])

add_block('built-in/Constant',[sys,/,Quad_data/front shot info'])
set_param([sys,/,Quad_data/front shot info'],...
    'orientation',2,...
    'Value','front_shot_info',...
    'position',[950,187,1035,203])

add_block('built-in/Inport',[sys,/,Quad_data/acmtheta'])
set_param([sys,/,Quad_data/acmtheta'],...
    'orientation',2,...
    'position',[1000,153,1020,167])

add_block('built-in/Constant',[sys,/,Quad_data/rear shot info1'])
set_param([sys,/,Quad_data/rear shot info1'],...
    'orientation',2,...
    'Value','rear_shot_info',...
    'position',[1035,142,1120,158])

add_block('built-in/Constant',[sys,/,Quad_data/average missile velocity'])
set_param([sys,/,Quad_data/average missile velocity'],...
    'orientation',2,...
    'Value','avg_missilevel',...
    'position',[490,62,595,78])

add_block('built-in/Note',[sys,/,Quad_data/BLOCK: Quad_data'])
set_param([sys,/,Quad_data/BLOCK: Quad_data'],...

```

```

        'position',[315,235,320,240])
add_line([sys,'/','Quad_data'],[775,150;725,150;725,160;710,160])
add_line([sys,'/','Quad_data'],[155,100;135,100;135,115;105,115])
add_line([sys,'/','Quad_data'],[110,135;105,135])
add_line([sys,'/','Quad_data'],[180,135;175,135])
add_line([sys,'/','Quad_data'],[230,70;220,125])
add_line([sys,'/','Quad_data'],[270,105;265,105;265,140;220,140])
add_line([sys,'/','Quad_data'],[325,120;320,120;320,110;305,110])
add_line([sys,'/','Quad_data'],[485,70;450,70;450,94;325,94;325,100;305,100])
add_line([sys,'/','Quad_data'],[500,110;360,110])
add_line([sys,'/','Quad_data'],[550,165;490,165;490,120;360,120])
add_line([sys,'/','Quad_data'],[415,130;360,130])
add_line([sys,'/','Quad_data'],[675,165;630,165])
add_line([sys,'/','Quad_data'],[600,110;580,110])
add_line([sys,'/','Quad_data'],[725,170;710,170])
add_line([sys,'/','Quad_data'],[835,160;825,160])
add_line([sys,'/','Quad_data'],[1030,150;875,150])
add_line([sys,'/','Quad_data'],[945,195;920,195;920,170;875,170])
add_line([sys,'/','Quad_data'],[70,125;50,125])
add_line([sys,'/','Quad_data'],[995,160;875,160])
add_line([sys,'/','Quad_data'],[775,165;765,210])
set_param([sys,'/','Quad_data'],...
    'Mask Display', Quradrant\n    time to\n    target \nAC-missile    \ntheta
\n Quadrant\n    launch\n    delay')

```

```

% Finished composite block 'Quad_data'.

```

```

set_param([sys,'/','Quad_data'],...
    'position',[950,441,1040,534])

```

```

% Subsystem 'Fire_timing'.

```

```

new_system([sys,'/','Fire_timing'])
set_param([sys,'/','Fire_timing'],'Location',[145,484,1139,876])

```

```

add_block('built-in/Inport',[sys,'/','Fire_timing/AC-Missile theta'])
set_param([sys,'/','Fire_timing/AC-Missile theta'],...
    'position',[385,125,405,145])

```

```

add_block('built-in/Constant',[sys,'/','Fire_timing/Launch time safety factor'])
set_param([sys,'/','Fire_timing/Launch time safety factor'],...
    'Value','launchtime_safetyfactor',...
    'position',[435,85,585,105])

```

```

add_block('built-in/Sum',[sys,'/','Fire_timing/S15'])
set_param([sys,'/','Fire_timing/S15'],...
    'position',[635,91,655,149])

```

```

add_block('built-in/Look Up Table',[sys,'/','Fire_timing/theta of missile in ',13,'time to target out'])
set_param([sys,'/','Fire_timing/theta of missile in ',13,'time to target out'],...
    'Input_Values','theta_missile_lu',...
    'Output_Values','time_lu',...
    'position',[535,123,565,147])

```

```

add_block('built-in/MATLAB Fcn',[sys,/,['Fire_timing/zerocheck',13,'(u(1)>0)']]
set_param([sys,/,['Fire_timing/zerocheck',13,'(u(1)>0)']],...
'MATLAB Fcn','(u(1)>0)',...
'position',[770,148,840,182])

add_block('built-in/Sum',[sys,/,Fire_timing/Sum19'])
set_param([sys,/,Fire_timing/Sum19'],...
'inputs','-+',...
'position',[730,149,750,176])

add_block('built-in/Constant',[sys,/,Fire_timing/rangestd'])
set_param([sys,/,Fire_timing/rangestd'],...
'Value','rangestd',...
'position',[200,172,265,188])

add_block('built-in/Product',[sys,/,Fire_timing/m24'])
set_param([sys,/,Fire_timing/m24'],...
'position',[305,165,330,185])

add_block('built-in/MATLAB Fcn',[sys,/,Fire_timing/division.m'])
set_param([sys,/,Fire_timing/division.m'],...
'MATLAB Fcn','division',...
'Output Width','1',...
'position',[625,195,675,225])

add_block('built-in/Mux',[sys,/,Fire_timing/Mux15'])
set_param([sys,/,Fire_timing/Mux15'],...
'inputs','2',...
'position',[560,193,590,222])

add_block('built-in/Inport',[sys,/,Fire_timing/Relative Velocity'])
set_param([sys,/,Fire_timing/Relative Velocity'],...
'Port','2',...
'position',[480,205,500,225])

add_block('built-in/Sum',[sys,/,Fire_timing/Sum23'])
set_param([sys,/,Fire_timing/Sum23'],...
'inputs','+-',...
'position',[395,197,420,233])

add_block('built-in/Constant',[sys,/,Fire_timing/lethaldist_'])
set_param([sys,/,Fire_timing/lethaldist_'],...
'Value','lethaldist',...
'position',[300,218,370,232])

add_block('built-in/Inport',[sys,/,['Fire_timing/AC-Missile',13,'slanrange']]
set_param([sys,/,['Fire_timing/AC-Missile',13,'slanrange']],...
'Port','3',...
'position',[250,205,270,225])

add_block('built-in/Outport',[sys,/,Fire_timing/Fire Flag'])
set_param([sys,/,Fire_timing/Fire Flag'],...
'position',[880,155,900,175])

```

```

% Subsystem ['Fire_timing/hold6',13,'sample=.25'].

new_system([sys,/,['Fire_timing/hold6',13,'sample=.25']])
set_param([sys,/,['Fire_timing/hold6',13,'sample=.25']], 'Location',[511,151,915,322])

add_block('built-in/Zero-Order Hold',[sys,/,['Fire_timing/hold6',13,'sample=.25/Zero-Order',13,'Hold']])
set_param([sys,/,['Fire_timing/hold6',13,'sample=.25/Zero-Order',13,'Hold']],...
    'Sample time','Ts',...
    'position',[100,29,135,61])

add_block('built-in/Gain',[sys,/,['Fire_timing/hold6',13,'sample=.25/Gain']])
set_param([sys,/,['Fire_timing/hold6',13,'sample=.25/Gain']],...
    'Gain','1/Ts',...
    'position',[285,33,325,77])

add_block('built-in/Integrator',[sys,/,['Fire_timing/hold6',13,'sample=.25/Integrator']])
set_param([sys,/,['Fire_timing/hold6',13,'sample=.25/Integrator']],...
    'position',[235,42,260,68])

add_block('built-in/Sum',[sys,/,['Fire_timing/hold6',13,'sample=.25/Sum']])
set_param([sys,/,['Fire_timing/hold6',13,'sample=.25/Sum']],...
    'inputs','+-',...
    'position',[190,37,210,68])

add_block('built-in/Unit Delay',[sys,/,['Fire_timing/hold6',13,'sample=.25/Unit Delay']])
set_param([sys,/,['Fire_timing/hold6',13,'sample=.25/Unit Delay']],...
    'Sample time','Ts',...
    'position',[90,93,140,117])

add_block('built-in/Inport',[sys,/,['Fire_timing/hold6',13,'sample=.25/input']])
set_param([sys,/,['Fire_timing/hold6',13,'sample=.25/input']],...
    'position',[25,35,45,55])

add_block('built-in/Output',[sys,/,['Fire_timing/hold6',13,'sample=.25/output']])
set_param([sys,/,['Fire_timing/hold6',13,'sample=.25/output']],...
    'position',[345,45,365,65])
add_line([sys,/,['Fire_timing/hold6',13,'sample=.25']], [330,55;340,55])
add_line([sys,/,['Fire_timing/hold6',13,'sample=.25']], [265,55;280,55])
add_line([sys,/,['Fire_timing/hold6',13,'sample=.25']], [215,55;230,55])
add_line([sys,/,['Fire_timing/hold6',13,'sample=.25']], [145,105;165,105;165,60;185,60])
add_line([sys,/,['Fire_timing/hold6',13,'sample=.25']], [140,45;185,45])
add_line([sys,/,['Fire_timing/hold6',13,'sample=.25']], [50,45;95,45])
add_line([sys,/,['Fire_timing/hold6',13,'sample=.25']], [65,45;65,105;85,105])
set_param([sys,/,['Fire_timing/hold6',13,'sample=.25']],...
    'Mask Display','plot(0,0,100,100,[90,70,50,30,10],[60,40,80,30,20])',...
    'Mask Type','First-Order Hold',...
    'Mask Dialogue','First-Order Hold|Sample Time:')
set_param([sys,/,['Fire_timing/hold6',13,'sample=.25']],...
    'Mask Translate','Ts=@ 1;',...
    'Mask Help','Implements a First-Order sample-and-hold latch operating at the sampling
interval you specify.',...
    'Mask Entries':'.25V')

```

```

% Finished composite block ['Fire_timing/hold6',13,'sample=.25'].

set_param([sys,'/','Fire_timing/hold6',13,'sample=.25'],...
    'position',[130,154,165,186])

add_block('built-in/White Noise',[sys,'/','Fire_timing/White Noise',13,'7'])
set_param([sys,'/','Fire_timing/White Noise',13,'7'],...
    'Seed','noiseseed(7)',...
    'position',[70,160,90,180])

add_block('built-in/Note',[sys,'/','Fire_timing/BLOCK: Fire_timing'])
set_param([sys,'/','Fire_timing/BLOCK: Fire_timing'],...
    'position',[390,325,395,330])
add_line([sys,'/','Fire_timing'],[335,175;360,175;360,205;390,205])
add_line([sys,'/','Fire_timing'],[375,225;390,225])
add_line([sys,'/','Fire_timing'],[170,170;300,170])
add_line([sys,'/','Fire_timing'],[270,180;300,180])
add_line([sys,'/','Fire_timing'],[95,170;125,170])
add_line([sys,'/','Fire_timing'],[660,120;685,120;685,155;725,155])
add_line([sys,'/','Fire_timing'],[590,95;615,95;615,105;630,105])
add_line([sys,'/','Fire_timing'],[425,215;445,215;445,200;555,200])
add_line([sys,'/','Fire_timing'],[570,135;630,135])
add_line([sys,'/','Fire_timing'],[755,165;765,165])
add_line([sys,'/','Fire_timing'],[680,210;705,210;705,170;725,170])
add_line([sys,'/','Fire_timing'],[595,210;620,210])
add_line([sys,'/','Fire_timing'],[410,135;530,135])
add_line([sys,'/','Fire_timing'],[845,165;875,165])
add_line([sys,'/','Fire_timing'],[275,215;390,215])
add_line([sys,'/','Fire_timing'],[505,215;555,215])
set_param([sys,'/','Fire_timing'],...
    'Mask Display','AC-Missile \nTheta \n\nRelative Fire Flag\n Velocity
\nAC-Missile \nslanrange ')

% Finished composite block 'Fire_timing'.

set_param([sys,'/','Fire_timing'],...
    'position',[930,560,1055,650])

% Subsystem 'Launch'.

new_system([sys,'/','Launch'])
set_param([sys,'/','Launch'],'Location',[73,208,1110,733])

add_block('built-in/Constant',[sys,'/','Launch/Detect time',13,' after launch'])
set_param([sys,'/','Launch/Detect time',13,' after launch'],...
    'Value','detecttal',...
    'position',[430,55,510,75])

add_block('built-in/To Workspace',[sys,'/','Launch/launch time'])
set_param([sys,'/','Launch/launch time'],...
    'mat-name','launch_time',...
    'buffer','1000000000',...
    'position',[125,299,200,321])

```

```

add_block('built-in/Memory',[sys,'/','Launch/Memory2',13,'IC:[100 -1 100]'])
set_param([sys,'/','Launch/Memory2',13,'IC:[100 -1 100]'],...
    'orientation',2,...
    'x0',[100 -1 100],...
    'position',[245,245,285,275])

```

```

add_block('built-in/MATLAB Fcn',[sys,'/','Launch/Get
expendable',13,'launch',13,'trajectory',13,'Inchtraj.m'])
set_param([sys,'/','Launch/Get expendable',13,'launch',13,'trajectory',13,'Inchtraj.m'],...
    'orientation',2,...
    'MATLAB Fcn','Inchtraj',...
    'Output Width','3',...
    'position',[335,245,385,275])

```

```

add_block('built-in/Mux',[sys,'/','Launch/Mux17'])
set_param([sys,'/','Launch/Mux17'],...
    'orientation',2,...
    'inputs','10',...
    'position',[425,209,460,311])

```

```

add_block('built-in/Inport',[sys,'/','Launch/Time'])
set_param([sys,'/','Launch/Time'],...
    'orientation',2,...
    'Port','3',...
    'position',[525,180,545,200])

```

```

add_block('built-in/Sum',[sys,'/','Launch/sum5n3'])
set_param([sys,'/','Launch/sum5n3'],...
    'orientation',2,...
    'inputs','+-',...
    'position',[825,237,845,293])

```

```

add_block('built-in/Inport',[sys,'/','Launch/Quadrant Time-',13,'to-target'])
set_param([sys,'/','Launch/Quadrant Time-',13,'to-target'],...
    'orientation',2,...
    'position',[895,272,915,298])

```

```

add_block('built-in/Inport',[sys,'/','Launch/Fire Flag'])
set_param([sys,'/','Launch/Fire Flag'],...
    'orientation',2,...
    'Port','4',...
    'position',[720,150,740,170])

```

```

add_block('built-in/Sum',[sys,'/','Launch/s2'])
set_param([sys,'/','Launch/s2'],...
    'orientation',1,...
    'position',[573,140,622,160])

```

```

add_block('built-in/Constant',[sys,'/','Launch/Shot time ',13,'after T/O'])
set_param([sys,'/','Launch/Shot time ',13,'after T/O'],...
    'Value','shottime',...
    'position',[520,20,600,40])

```

```

add_block('built-in/Inport',[sys,'/','Launch/Launch data'])

```

```

set_param([sys,'/','Launch/Launch data'],...
          'orientation',2,...
          'Port','7',...
          'position',[695,245,715,265])

add_block('built-in/Constant',[sys,'/','Launch/muzzle velocity'])
set_param([sys,'/','Launch/muzzle velocity'],...
          'orientation',2,...
          'Value','muzzle_vel',...
          'position',[630,411,710,429])

add_block('built-in/Constant',[sys,'/','Launch/R_Thrust'])
set_param([sys,'/','Launch/R_Thrust'],...
          'orientation',2,...
          'Value','R_Thrust',...
          'position',[635,360,690,380])

add_block('built-in/Constant',[sys,'/','Launch/Tduration'])
set_param([sys,'/','Launch/Tduration'],...
          'orientation',2,...
          'Value','Tduration',...
          'position',[700,335,755,355])

add_block('built-in/Constant',[sys,'/','Launch/tracker'])
set_param([sys,'/','Launch/tracker'],...
          'orientation',2,...
          'Value','tracker',...
          'position',[635,310,690,330])

add_block('built-in/Mux',[sys,'/','Launch/Mux18'])
set_param([sys,'/','Launch/Mux18'],...
          'orientation',2,...
          'inputs','5',...
          'position',[570,307,600,433])

add_block('built-in/Constant',[sys,'/','Launch/Computation time required'])
set_param([sys,'/','Launch/Computation time required'],...
          'Value','computation_time_required',...
          'position',[255,407,420,423])

add_block('built-in/Constant',[sys,'/','Launch/Slew time required'])
set_param([sys,'/','Launch/Slew time required'],...
          'Value','slew_time_required',...
          'position',[250,369,395,391])

add_block('built-in/Sum',[sys,'/','Launch/s3'])
set_param([sys,'/','Launch/s3'],...
          'position',[455,400,500,420])

add_block('built-in/Inport',[sys,'/','Launch/Quadrant Launch',13,'delay'])
set_param([sys,'/','Launch/Quadrant Launch',13,'delay'],...
          'orientation',2,...
          'Port','2',...
          'position',[985,255,1005,275])

```

```

add_block('built-in/Demux',[sys,'/','Launch/Dem5'])
set_param([sys,'/','Launch/Dem5'],...
    'orientation',2,...
    'outputs',3,...
    'position',[150,243,190,277])

add_block('built-in/Inport',[sys,'/','Launch/AC Velocity (z,x)'])
set_param([sys,'/','Launch/AC Velocity (z,x)'],...
    'orientation',2,...
    'Port',6,...
    'position',[760,215,780,235])

add_block('built-in/Inport',[sys,'/','Launch/AC position (x,y,z)'])
set_param([sys,'/','Launch/AC position (x,y,z)'],...
    'orientation',2,...
    'Port',5,...
    'position',[880,195,900,215])

add_block('built-in/Outport',[sys,'/','Launch/Operational ',13,'Time'])
set_param([sys,'/','Launch/Operational ',13,'Time'],...
    'orientation',2,...
    'position',[55,200,75,220])

add_block('built-in/Outport',[sys,'/','Launch/Launch ',13,'Flag'])
set_param([sys,'/','Launch/Launch ',13,'Flag'],...
    'orientation',2,...
    'Port',2,...
    'position',[50,250,70,270])

add_block('built-in/Constant',[sys,'/','Launch/lethaldist'])
set_param([sys,'/','Launch/lethaldist'],...
    'orientation',2,...
    'Value','lethaldist',...
    'position',[730,385,785,405])

add_block('built-in/To Workspace',[sys,'/','Launch/Quadrant launch time1'])
set_param([sys,'/','Launch/Quadrant launch time1'],...
    'mat-name','quad_launch_time',...
    'buffer','1000000000',...
    'position',[830,325,880,345])

add_block('built-in/Note',[sys,'/','Launch/BLOCK: Launch'])
set_param([sys,'/','Launch/BLOCK: Launch'],...
    'position',[465,475,470,480])
add_line([sys,'/','Launch'],[600,165;600,295;465,295])
add_line([sys,'/','Launch'],[600,185;955,185;955,245;850,245])
add_line([sys,'/','Launch'],[505,410;505,305;465,305])
add_line([sys,'/','Launch'],[515,65;520,65;520,105;585,105;585,135])
add_line([sys,'/','Launch'],[605,30;610,30;610,135])
add_line([sys,'/','Launch'],[425,415;450,415])
add_line([sys,'/','Launch'],[400,380;440,380;450,405])
add_line([sys,'/','Launch'],[145,270;110,270;120,310])
add_line([sys,'/','Launch'],[625,420;605,420])
add_line([sys,'/','Launch'],[240,260;195,260])
add_line([sys,'/','Launch'],[220,260;220,330;515,330;515,285;465,285])

```



```

add_line([sys,/, 'Launch'],[330,260;290,260])
add_line([sys,/, 'Launch'],[725,395;605,395])
add_line([sys,/, 'Launch'],[630,370;605,370])
add_line([sys,/, 'Launch'],[565,370;555,370;555,275;465,275])
add_line([sys,/, 'Launch'],[695,345;605,345])
add_line([sys,/, 'Launch'],[630,320;605,320])
add_line([sys,/, 'Launch'],[420,260;390,260])
add_line([sys,/, 'Launch'],[890,285;850,285])
add_line([sys,/, 'Launch'],[980,265;850,265])
add_line([sys,/, 'Launch'],[520,190;480,190;480,215;465,215])
add_line([sys,/, 'Launch'],[715,160;660,160;660,225;465,225])
add_line([sys,/, 'Launch'],[875,205;670,205;670,235;465,235])
add_line([sys,/, 'Launch'],[755,225;680,225;680,245;465,245])
add_line([sys,/, 'Launch'],[690,255;465,255])
add_line([sys,/, 'Launch'],[145,250;110,250;110,210;80,210])
add_line([sys,/, 'Launch'],[145,260;75,260])
add_line([sys,/, 'Launch'],[820,265;780,265;780,335;825,335])
add_line([sys,/, 'Launch'],[780,265;763,265;763,285;613,285;613,265;465,265])
set_param([sys,/, 'Launch'],...
    'Mask Display','Quad time-to-target    \n\nQuadrant    Operational\n\nlaunch delay
Time \nTime                \n\nFire Flag                \n\nAC position (x,y,z)    \n\nAC
velocity (z,x)  Launch\n                Flag\nLaunch data                ')

% Finished composite block 'Launch'.

set_param([sys,/, 'Launch'],...
    'position',[1190,525,1355,685])

% Subsystem 'Go_operational'.

new_system([sys,/, 'Go_operational'])
set_param([sys,/, 'Go_operational'],'Location',[454,486,1040,832])

add_block('built-in/Memory',[sys,/, ['Go_operational/Memory',13,'IC:-1']]
set_param([sys,/, ['Go_operational/Memory',13,'IC:-1']],...
    'x0','-1',...
    'position',[115,160,155,190])

add_block('built-in/MATLAB Fcn',[sys,/, ['Go_operational/Get
expendable',13,'operational',13,'trajectory',13,'gtoptraj.m']]
set_param([sys,/, ['Go_operational/Get expendable',13,'operational',13,'trajectory',13,'gtoptraj.m']],...
    'orientation',2,...
    'MATLAB Fcn','gtoptraj',...
    'Output Width',1,...
    'position',[115,70,165,100])

add_block('built-in/Constant',[sys,/, 'Go_operational/oper_duration'])
set_param([sys,/, 'Go_operational/oper_duration'],...
    'orientation',2,...
    'Value','oper_duration',...
    'position',[280,90,375,110])

add_block('built-in/Mux',[sys,/, 'Go_operational/Mux7'])

```

```

set_param([sys,'/','Go_operational/Mux7'],...
          'orientation',2,...
          'inputs',5,...
          'position',[205,45,240,125])

add_block('built-in/Inport',[sys,'/','Go_operational/Time'])
set_param([sys,'/','Go_operational/Time'],...
          'orientation',2,...
          'position',[265,30,285,50])

add_block('built-in/Outport',[sys,'/','Go_operational/Operational Flag'])
set_param([sys,'/','Go_operational/Operational Flag'],...
          'position',[310,165,330,185])

add_block('built-in/Inport',[sys,'/','Go_operational/Operational Time'])
set_param([sys,'/','Go_operational/Operational Time'],...
          'orientation',2,...
          'Port',2,...
          'position',[400,30,420,50])

add_block('built-in/Inport',[sys,'/','Go_operational/Expendable ',13,'position//velocity',13,'(x,y,z)'])
set_param([sys,'/','Go_operational/Expendable ',13,'position//velocity',13,'(x,y,z)'],...
          'orientation',2,...
          'Port',3,...
          'position',[435,75,455,95])

add_block('built-in/Note',[sys,'/','Go_operational/BLOCK: Go_operational'])
set_param([sys,'/','Go_operational/BLOCK: Go_operational'],...
          'position',[150,255,155,260])
add_line([sys,'/','Go_operational'],[160,175;305,175])
add_line([sys,'/','Go_operational'],[265,175;265,115;245,115])
add_line([sys,'/','Go_operational'],[275,100;245,100])
add_line([sys,'/','Go_operational'],[200,85;170,85])
add_line([sys,'/','Go_operational'],[110,85;75.85;75,175;110,175])
add_line([sys,'/','Go_operational'],[260,40;260,55;245,55])
add_line([sys,'/','Go_operational'],[395,40;315,40;315,70;245,70])
add_line([sys,'/','Go_operational'],[430,85;245,85])
set_param([sys,'/','Go_operational'],...
          'Mask Display',          Global Time\nOperational Operational\n Flag          Time
\n          Expendable\n          Position (x,y,z)')

% Finished composite block 'Go_operational'.

set_param([sys,'/','Go_operational'],...
          'orientation',2,...
          'position',[1225,371,1365,439])

add_block('built-in/To Workspace',[sys,'/','operational time'])
set_param([sys,'/','operational time'],...
          'mat-name','opertime',...
          'buffer','1000000000',...
          'position',[1510,555,1560,575])

add_block('built-in/To Workspace',[sys,'/','mexslantrange'])

```

```

set_param([sys,'/','mexslanrange'],...
          'mat-name','mexslanrange',...
          'buffer','1000000000',...
          'position',[1725,345,1815,365])

add_block('built-in/Stop Simulation',[sys,'/','Stop simulation',13,'if non-zero',13,'_'])
set_param([sys,'/','Stop simulation',13,'if non-zero',13,'_'],...
          'position',[1760,244,1810,286])

add_block('built-in/To Workspace',[sys,'/','zexp'])
set_param([sys,'/','zexp'],...
          'mat-name','zexp',...
          'buffer','1000000000',...
          'position',[1810,170,1860,190])

add_block('built-in/To Workspace',[sys,'/','xexp'])
set_param([sys,'/','xexp'],...
          'mat-name','xexp',...
          'buffer','1000000000',...
          'position',[1805,110,1855,130])

add_block('built-in/MATLAB Fcn',[sys,'/','expos.m'])
set_param([sys,'/','expos.m'],...
          'orientation',2,...
          'MATLAB Fcn','expos',...
          'Output Width','9',...
          'position',[1545,50,1595,80])

add_block('built-in/To Workspace',[sys,'/','yexp'])
set_param([sys,'/','yexp'],...
          'mat-name','yexp',...
          'buffer','1000000000',...
          'position',[1745,140,1795,160])

% Subsystem 'HitCheck'.

new_system([sys,'/','HitCheck'])
set_param([sys,'/','HitCheck'],'Location',[250,337,902,672])

add_block('built-in/To Workspace',[sys,'/','HitCheck/Left inboard engine'])
set_param([sys,'/','HitCheck/Left inboard engine'],...
          'orientation',2,...
          'mat-name','srlie',...
          'buffer','1000000000',...
          'position',[340,137,390,153])

add_block('built-in/To Workspace',[sys,'/','HitCheck/Right inboard engine'])
set_param([sys,'/','HitCheck/Right inboard engine'],...
          'orientation',2,...
          'mat-name','srrie',...
          'buffer','1000000000',...
          'position',[310,107,360,123])

add_block('built-in/To Workspace',[sys,'/','HitCheck/Left outboard engine'])

```

```

set_param([sys,'/','HitCheck/Left outboard engine'],...
    'orientation',2,...
    'mat-name','srloe',...
    'buffer','1000000000',...
    'position',[280,77,330,93])

add_block('built-in/To Workspace',[sys,'/','HitCheck/Cockpit'])
set_param([sys,'/','HitCheck/Cockpit'],...
    'mat-name','srcp',...
    'buffer','1000000000',...
    'position',[520,107,570,123])

add_block('built-in/Demux',[sys,'/','HitCheck/Demux3'])
set_param([sys,'/','HitCheck/Demux3'],...
    'outputs','8',...
    'position',[400,167,440,253])

add_block('built-in/MATLAB Fcn',[sys,'/','HitCheck/ifend.m'])
set_param([sys,'/','HitCheck/ifend.m'],...
    'MATLAB Fcn','ifend',...
    'Output Width','8',...
    'position',[330,195,380,225])

add_block('built-in/Mux',[sys,'/','HitCheck/Mux4'])
set_param([sys,'/','HitCheck/Mux4'],...
    'inputs','3',...
    'position',[275,170,305,230])

add_block('built-in/Constant',[sys,'/','HitCheck/Lethal distance'])
set_param([sys,'/','HitCheck/Lethal distance'],...
    'Value','lethaldist',...
    'position',[155,189,225,211])

add_block('built-in/Inport',[sys,'/','HitCheck/AC position (x,y,z)'])
set_param([sys,'/','HitCheck/AC position (x,y,z)'],...
    'position',[55,170,75,190])

add_block('built-in/Inport',[sys,'/','HitCheck/Missile position (x,y,z)'])
set_param([sys,'/','HitCheck/Missile position (x,y,z)'],...
    'Port','2',...
    'position',[70,220,90,240])

add_block('built-in/Stop Simulation',[sys,'/','HitCheck/Stop simulation',13,'if non-zero',13,""])
set_param([sys,'/','HitCheck/Stop simulation',13,'if non-zero',13,""],...
    'position',[520,224,570,266])

add_block('built-in/To Workspace',[sys,'/','HitCheck/Right outboard engine'])
set_param([sys,'/','HitCheck/Right outboard engine'],...
    'mat-name','srroe',...
    'buffer','1000000000',...
    'position',[525,77,575,93])

add_block('built-in/To Workspace',[sys,'/','HitCheck/Empenage'])
set_param([sys,'/','HitCheck/Empenage'],...
    'mat-name','sremp',...

```

```

        'buffer','1000000000',...
        'position',[520,137,570,153])

add_block('built-in/To Workspace',[sys,'],'HitCheck/Center of gravity')
set_param([sys,'],'HitCheck/Center of gravity',...
    'mat-name','srcg',...
    'buffer','1000000000',...
    'position',[525,167,575,183])

add_block('built-in/Note',[sys,'],'HitCheck/BLOCK: HitCheck')
set_param([sys,'],'HitCheck/BLOCK: HitCheck',...
    'position',[205,290,210,295])
add_line([sys,'],'HitCheck',[230,200;270,200])
add_line([sys,'],'HitCheck',[445,245;515,245])
add_line([sys,'],'HitCheck',[445,235;475,235;475,175;520,175])
add_line([sys,'],'HitCheck',[445,225;470,225;470,145;515,145])
add_line([sys,'],'HitCheck',[445,215;465,215;465,115;515,115])
add_line([sys,'],'HitCheck',[445,205;460,205;460,85;520,85])
add_line([sys,'],'HitCheck',[445,195;455,195;455,85;335,85])
add_line([sys,'],'HitCheck',[445,185;450,185;450,115;365,115])
add_line([sys,'],'HitCheck',[445,175;445,145;395,145])
add_line([sys,'],'HitCheck',[385,210;395,210])
add_line([sys,'],'HitCheck',[310,200;325,210])
add_line([sys,'],'HitCheck',[80,180;270,180])
add_line([sys,'],'HitCheck',[95,230;245,230;245,220;270,220])
set_param([sys,'],'HitCheck',...
    'Mask Display','AC position (x,y,z) \n\nMissile position (x,y,z)')

% Finished composite block 'HitCheck'.

set_param([sys,'],'HitCheck',...
    'position',[935,2,1075,53])

add_block('built-in/Constant',[sys,'],'Effective radius of expendable')
set_param([sys,'],'Effective radius of expendable',...
    'Value','expeff_radius',...
    'position',[1310,250,1390,270])

add_block('built-in/To Workspace',[sys,'],'PK')
set_param([sys,'],'PK',...
    'mat-name','PK',...
    'buffer','1000000000',...
    'position',[1805,215,1855,235])

% Subsystem 'Expendable'.

new_system([sys,'],'Expendable')
set_param([sys,'],'Expendable','Location',[71,369,1085,864])

add_block('built-in/Inport',[sys,'],'Expendable/Missile position',13,'(x,y,z)'])
set_param([sys,'],'Expendable/Missile position',13,'(x,y,z)'],...
    'position',[300,475,320,495])

```

```

add_block('built-in/Inport',[sys,/,['Expendable/effective radius',13,'of expendable']])
set_param([sys,/,['Expendable/effective radius',13,'of expendable']],...
    'Port','5',...
    'position',[760,420,780,440])

add_block('built-in/Product',[sys,/, 'Expendable/Product23'])
set_param([sys,/, 'Expendable/Product23'],...
    'position',[720,675,745,695])

add_block('built-in/Product',[sys,/, 'Expendable/Product25'])
set_param([sys,/, 'Expendable/Product25'],...
    'position',[725,580,750,600])

add_block('built-in/Constant',[sys,/, 'Expendable/Expendable type'])
set_param([sys,/, 'Expendable/Expendable type'],...
    'Value','exp_type',...
    'position',[860,434,945,456])

add_block('built-in/Demux',[sys,/, 'Expendable/Demux5'])
set_param([sys,/, 'Expendable/Demux5'],...
    'outputs','3',...
    'position',[390,467,430,503])

add_block('built-in/Product',[sys,/, 'Expendable/Product24'])
set_param([sys,/, 'Expendable/Product24'],...
    'position',[685,630,710,650])

add_block('built-in/Sum',[sys,/, 'Expendable/Sum18'])
set_param([sys,/, 'Expendable/Sum18'],...
    'inputs','+++',...
    'position',[860,622,880,658])

add_block('built-in/Fcn',[sys,/, 'Expendable/Fcn14'])
set_param([sys,/, 'Expendable/Fcn14'],...
    'Expr','sqrt(u[1])',...
    'position',[895,629,980,651])

add_block('built-in/Sum',[sys,/, 'Expendable/Sum16'])
set_param([sys,/, 'Expendable/Sum16'],...
    'inputs','+-',...
    'position',[540,480,560,500])

add_block('built-in/Sum',[sys,/, 'Expendable/Sum15'])
set_param([sys,/, 'Expendable/Sum15'],...
    'inputs','+-',...
    'position',[575,435,595,455])

add_block('built-in/Sum',[sys,/, 'Expendable/Sum17'])
set_param([sys,/, 'Expendable/Sum17'],...
    'inputs','+-',...
    'position',[500,525,520,545])

add_block('built-in/Memory',[sys,/, ['Expendable/Memory',13,'IC: 0']])
set_param([sys,/, ['Expendable/Memory',13,'IC: 0']],...
    'position',[1020,665,1060,695])

```

```

add_block('built-in/Mux',[sys,/, 'Expendable/Mux11'])
set_param([sys,/, 'Expendable/Mux11'],...
    'inputs',6,...
    'position',[1050,372,1085,473])

add_block('built-in/Memory',[sys,/, ['Expendable/Memory1',13,'IC: 0']])
set_param([sys,/, ['Expendable/Memory1',13,'IC: 0']],...
    'position',[880,325,920,355])

add_block('built-in/Demux',[sys,/, 'Expendable/Demux4'])
set_param([sys,/, 'Expendable/Demux4'],...
    'outputs',2,...
    'position',[1200,405,1240,440])

add_block('built-in/MATLAB Fcn',[sys,/, 'Expendable/mexphit.m'])
set_param([sys,/, 'Expendable/mexphit.m'],...
    'MATLAB Fcn','mexphit',...
    'Output Width',2,...
    'position',[1120,410,1170,440])

add_block('built-in/Demux',[sys,/, 'Expendable/Demux3'])
set_param([sys,/, 'Expendable/Demux3'],...
    'outputs',9)
set_param([sys,/, 'Expendable/Demux3'],...
    'Mask Display',      xexp\n      xvexp\n      yexp\n      vyexp\nexp pos
zexp\n      vzept\n      x pos noise\n      y pos noise\n      z pos noise')
set_param([sys,/, 'Expendable/Demux3'],...
    'position',[185,138,280,242])

add_block('built-in/Inport',[sys,/, ['Expendable/operational',13,'flag',13,]])
set_param([sys,/, ['Expendable/operational',13,'flag',13,]],...
    'Port',6,...
    'position',[550,60,570,80])

add_block('built-in/Outport',[sys,/, 'Expendable/exp pos in1'])
set_param([sys,/, 'Expendable/exp pos in1'],...
    'Port',2,...
    'position',[540,290,560,310])

add_block('built-in/Outport',[sys,/, 'Expendable/exp pos in2'])
set_param([sys,/, 'Expendable/exp pos in2'],...
    'orientation',2,...
    'Port',3,...
    'position',[390,330,410,350])

add_block('built-in/Outport',[sys,/, 'Expendable/exp pos in3'])
set_param([sys,/, 'Expendable/exp pos in3'],...
    'orientation',2,...
    'Port',4,...
    'position',[395,380,415,400])

add_block('built-in/Outport',[sys,/, 'Expendable/STOP Flag'])
set_param([sys,/, 'Expendable/STOP Flag'],...
    'Port',6,...

```

```

        'position',[1295,450,1315,470])

add_block('built-in/Outport',[sys,/, 'Expendable/PK'])
set_param([sys,/, 'Expendable/PK'],...
    'Port','5',...
    'position',[1300,405,1320,425])

add_block('built-in/Outport',[sys,/, 'Expendable/mexslantrange'])
set_param([sys,/, 'Expendable/mexslantrange'],...
    'Port','7',...
    'position',[1095,630,1115,650])

add_block('built-in/Mux',[sys,/, 'Expendable/Mux15'])
set_param([sys,/, 'Expendable/Mux15'],...
    'inputs','6',...
    'position',[370,64,405,136])

add_block('built-in/Outport',[sys,/, ['Expendable/exp pos',13,'(x,vx,y,vy,z,vz)']])
set_param([sys,/, ['Expendable/exp pos',13,'(x,vx,y,vy,z,vz)']],...
    'Port','8',...
    'position',[450,90,470,110])

add_block('built-in/Constant',[sys,/, 'Expendable/Duration of wash noise'])
set_param([sys,/, 'Expendable/Duration of wash noise'],...
    'Value','washnoiseduration',...
    'position',[710,294,830,316])

add_block('built-in/Memory',[sys,/, ['Expendable/Memory2',13,'IC: [0 0 0]']])
set_param([sys,/, ['Expendable/Memory2',13,'IC: [0 0 0]']],...
    'x0','[0 0 0]',...
    'position',[700,150,740,180])

add_block('built-in/Inport',[sys,/, 'Expendable/time'])
set_param([sys,/, 'Expendable/time'],...
    'Port','4',...
    'position',[720,110,740,130])

add_block('built-in/Inport',[sys,/, ['Expendable/launch',13,'flag']])
set_param([sys,/, ['Expendable/launch',13,'flag']],...
    'Port','2',...
    'position',[645,80,665,100])

add_block('built-in/Mux',[sys,/, 'Expendable/Mux14'])
set_param([sys,/, 'Expendable/Mux14'],...
    'inputs','6',...
    'position',[915,64,950,101])

add_block('built-in/Outport',[sys,/, 'Expendable/exp pos in'])
set_param([sys,/, 'Expendable/exp pos in'],...
    'position',[1005,75,1025,95])

add_block('built-in/Constant',[sys,/, 'Expendable/standard dev of wash noise'])
set_param([sys,/, 'Expendable/standard dev of wash noise'],...
    'Value','washnoisestd',...
    'position',[685,215,765,235])

```



```
add_block('built-in/Inport',[sys,/, 'Expendable/exp pos out'])
set_param([sys,/, 'Expendable/exp pos out'],...
    'Port', '3',...
    'position', [120, 180, 140, 200])
```

```
add_block('built-in/Mux',[sys,/, 'Expendable/Mux 16'])
set_param([sys,/, 'Expendable/Mux 16'],...
    'inputs', '3',...
    'position', [350, 201, 385, 239])
```

```
add_block('built-in/Note',[sys,/, 'Expendable/BLOCK: Expendable'])
set_param([sys,/, 'Expendable/BLOCK: Expendable'],...
    'position', [290, 645, 295, 650])
add_line([sys,/, 'Expendable'], [575, 70; 910, 70])
add_line([sys,/, 'Expendable'], [745, 120; 745, 80; 910, 80])
add_line([sys,/, 'Expendable'], [745, 165; 770, 165; 770, 85; 910, 85])
add_line([sys,/, 'Expendable'], [750, 685; 785, 685; 785, 650; 855, 650])
add_line([sys,/, 'Expendable'], [755, 590; 770, 590; 770, 630; 855, 630])
add_line([sys,/, 'Expendable'], [985, 640; 995, 640; 995, 415; 1045, 415])
add_line([sys,/, 'Expendable'], [435, 485; 535, 485])
add_line([sys,/, 'Expendable'], [1175, 425; 1195, 425])
add_line([sys,/, 'Expendable'], [1090, 425; 1115, 425])
add_line([sys,/, 'Expendable'], [950, 445; 1045, 445])
add_line([sys,/, 'Expendable'], [885, 640; 890, 640])
add_line([sys,/, 'Expendable'], [715, 640; 855, 640])
add_line([sys,/, 'Expendable'], [600, 445; 697, 445; 697, 585; 720, 585])
add_line([sys,/, 'Expendable'], [600, 445; 697, 445; 697, 595; 720, 595])
add_line([sys,/, 'Expendable'], [565, 490; 647, 490; 647, 645; 680, 645])
add_line([sys,/, 'Expendable'], [565, 490; 647, 490; 647, 635; 680, 635])
add_line([sys,/, 'Expendable'], [525, 535; 612, 535; 612, 680; 715, 680])
add_line([sys,/, 'Expendable'], [525, 535; 612, 535; 612, 690; 715, 690])
add_line([sys,/, 'Expendable'], [325, 485; 385, 485])
add_line([sys,/, 'Expendable'], [785, 430; 1045, 430])
add_line([sys,/, 'Expendable'], [1065, 680; 1252, 680; 1252, 605; 1032, 605; 1032, 460; 1045, 460])
add_line([sys,/, 'Expendable'], [435, 495; 457, 495; 457, 530; 495, 530])
add_line([sys,/, 'Expendable'], [435, 475; 492, 475; 492, 440; 570, 440])
add_line([sys,/, 'Expendable'], [985, 640; 995, 640; 995, 680; 1015, 680])
add_line([sys,/, 'Expendable'], [285, 150; 505, 150; 505, 450; 570, 450])
add_line([sys,/, 'Expendable'], [285, 170; 477, 170; 477, 495; 535, 495])
add_line([sys,/, 'Expendable'], [285, 190; 447, 190; 447, 540; 495, 540])
add_line([sys,/, 'Expendable'], [670, 90; 717, 90; 717, 75; 910, 75])
add_line([sys,/, 'Expendable'], [610, 70; 610, 400; 1045, 400])
add_line([sys,/, 'Expendable'], [842, 400; 842, 340; 875, 340])
add_line([sys,/, 'Expendable'], [925, 340; 982, 340; 982, 385; 1045, 385])
add_line([sys,/, 'Expendable'], [955, 85; 1000, 85])
add_line([sys,/, 'Expendable'], [145, 190; 180, 190])
add_line([sys,/, 'Expendable'], [1245, 415; 1295, 415])
add_line([sys,/, 'Expendable'], [1245, 430; 1270, 430; 1270, 460; 1290, 460])
add_line([sys,/, 'Expendable'], [505, 300; 535, 300])
add_line([sys,/, 'Expendable'], [447, 390; 420, 390])
add_line([sys,/, 'Expendable'], [477, 340; 415, 340])
add_line([sys,/, 'Expendable'], [995, 640; 1090, 640])
add_line([sys,/, 'Expendable'], [410, 100; 445, 100])
add_line([sys,/, 'Expendable'], [285, 150; 305, 150; 305, 75; 365, 75])
```

```

add_line([sys,/, 'Expendable'],[285,160;310,160;310,85;365,85])
add_line([sys,/, 'Expendable'],[320,170;320,95;365,95])
add_line([sys,/, 'Expendable'],[285,180;325,180;325,105;365,105])
add_line([sys,/, 'Expendable'],[330,190;330,115;365,115])
add_line([sys,/, 'Expendable'],[835,305;885,305;885,95;910,95])
add_line([sys,/, 'Expendable'],[285,210;345,210])
add_line([sys,/, 'Expendable'],[285,220;345,220])
add_line([sys,/, 'Expendable'],[285,230;345,230])
add_line([sys,/, 'Expendable'],[390,220;560,220;560,165;695,165])
add_line([sys,/, 'Expendable'],[770,225;780,225;780,180;875,180;875,90;910,90])
add_line([sys,/, 'Expendable'],[285,200;335,200;335,125;365,125])
set_param([sys,/, 'Expendable'],...
          'Mask Display','Missile  exppos in\npos (x,y,z)          \n          Exp X pos\n
Launch Flag          \n          Exp Y pos\nexp pos          \n out          Exp Z pos\n\nTime
PK\n          Stop flag\nEffective          \nradius  mexslantrange\n\nOperational          \nflag
Exp pos (x,y,z)')

```

% Finished composite block 'Expendable'.

```

set_param([sys,/, 'Expendable'],...
          'position',[1500,126,1635,304])
add_line(sys,[365,400;325,400;325,205;375,205])
add_line(sys,[535,230;575,230;575,80;615,80])
add_line(sys,[85,410;150,410])
add_line(sys,[1060,605;1185,605])
add_line(sys,[990,720;1155,720;1155,665;1185,665])
add_line(sys,[1360,565;1390,565;1390,405;1370,405])
add_line(sys,[795,530;890,530;890,575;925,575])
add_line(sys,[85,410;115,410;115,300;1125,300;1125,585;1185,585])
add_line(sys,[795,530;846,530;846,705;880,705])
add_line(sys,[800,215;870,215;870,605;925,605])
add_line(sys,[285,190;375,190])
add_line(sys,[535,200;545,200;545,65;615,65])
add_line(sys,[85,410;115,410;115,180;145,180])
add_line(sys,[285,165;1105,165;1105,645;1185,645])
add_line(sys,[795,510;825,510;825,730;880,730])
add_line(sys,[795,550;810,550;810,635;925,635])
add_line(sys,[285,190;300,190;300,50;535,50;535,15;930,15])
add_line(sys,[846,530;890,530;890,490;945,490])
add_line(sys,[1045,510;1080,510;1080,565;1185,565])
add_line(sys,[1045,465;1090,465;1090,545;1185,545])
add_line(sys,[1360,645;1645,645])
add_line(sys,[115,235;375,235])
add_line(sys,[300,190;300,545;620,545])
add_line(sys,[535,50;615,50])
add_line(sys,[775,65;800,65;800,130;355,130;355,220;375,220])
add_line(sys,[635,165;635,200;655,200])
add_line(sys,[605,130;605,400;510,400])
add_line(sys,[605,230;655,230])
add_line(sys,[605,400;605,450;605,515;620,515])
add_line(sys,[555,545;555,670;1140,670;1140,625;1185,625])
add_line(sys,[800,65;800,40;930,40])
add_line(sys,[1390,565;1505,565])
add_line(sys,[1175,585;1125,585;1125,510;1445,510;1445,385;1370,385])

```

```

add_line(sys,[1540,65;1470,65;1470,200;1495,200])
add_line(sys,[1640,145;1640,65;1600,65])
add_line(sys,[1360,645;1435,645;1435,170;1495,170])
add_line(sys,[1385,385;1445,385;1445,230;1495,230])
add_line(sys,[1395,260;1495,260])
add_line(sys,[1640,165;1655,165;1655,120;1800,120])
add_line(sys,[1640,185;1665,185;1665,150;1740,150])
add_line(sys,[1640,205;1720,205;1720,180;1805,180])
add_line(sys,[1640,225;1800,225])
add_line(sys,[1640,245;1690,245;1690,265;1755,265])
add_line(sys,[1640,265;1670,265;1670,355;1720,355])
add_line(sys,[1640,285;1660,285;1660,425;1370,425])
add_line(sys,[775,65;800,65;800,130;1485,130;1495,140])
add_line(sys,[1220,405;1210,405;1210,290;1495,290])

```

drawnow

% Return any arguments.

```

if (nargin | nargout)
    % Must use feval here to access system in memory
    if (nargin > 3)
        if (flag == 0)
            eval(['ret,x0,str,ts,xts']='sys,(t,x,u,flag);')
        else
            eval(['ret =' , sys,(t,x,u,flag);'])
        end
    else
        [ret,x0,str,ts,xts] = feval(sys);
    end
else
    drawnow % Flash up the model and execute load callback
end

```

```
function h=acmangle(u)
```

```
%*****
```

```
% file: acmangle.m
```

```
% Used in BLOCK:Relative_angles_and_range
```

```
%
```

```
% Authors: Capt. Joel Hagan & Capt Brian Peterson, USAF
```

```
%           GSE-95D Air Force Institute of Technology
```

```
% Language: Matlab
```

```
% Project: AKKCT (Aircraft Kintetic Kill Countermeasures Technology)
```

```
% Last Updated: 31 Oct 95
```

```
%
```

```
% Function: Given the Cartesian location of an aircraft and a missile,
```

```
%   output the relative phi (elevation) theta (azimuth) and slantrange
```

```
%   from the view of the view of the aircraft with 0 being above and
```

```
%   forward, respectively.
```

```
%
```

```
%*****
```

```
%u1=x position of missile
```

```
%u2=y position of missile
```

```
%u3=z position of missile
```

```
%u4=x position of A/C
```

```
%u5=y position of A/C
```

```
%u6=z position of A/C
```

```
deltaxprior=u(1)-u(4);
```

```
deltayprior=u(2)-u(5);
```

```
deltazprior=u(3)-u(6);
```

```
resultxy=sqrt((deltaxprior*deltaxprior)+(deltayprior*deltayprior));
```

```
thetaprior=atan2(deltayprior,deltaxprior);
```

```
phprior=atan2(resultxy,deltazprior);
```

```
resultxyz=sqrt(deltaxprior*deltaxprior+deltayprior*deltayprior+...  
              deltaxprior*deltazprior);
```

```
h=[phprior;thetaprior;resultxyz];
```

```

function h=division(u)

%*****
% division.m
% Used in BLOCK:Fire_Timing
%
% Authors: Capt. Joel Hagan & Capt Brian Peterson, USAF
%         GSE-95D Air Force Institute of Technology
% Language: Matlab
% Project: AKKCT (Aircraft Kintetic Kill Countermeasures Technology)
% Last Updated: 31 OCT 95
%
% Function: This function divides two inputs, u(1) & u(2). This is
% used for calculating the expected time for the missile to intercet
% the aircraft. If the miissile velocity =0, the expected time is
% set to 1000;
%*****

%u(1)=missile distance
%u(2)=missile velocity

denom=u(2);
if u(2)==0
    denom=1-e3;
end
x=abs(u(1)/denom);
if isnan(x)==1 || isinf(x)==1
    h=1000;
else
    h=x;
end

```

```
function h=divplus(u)
```

```
%*****
```

```
% divplus.m
```

```
% Used in BLOCK:Quad_data, Missilxyz
```

```
%
```

```
% Authors: Capt. Joel Hagan & Capt Brian Peterson, USAF
```

```
%      GSE-95D Air Force Institute of Technology
```

```
% Language: Matlab
```

```
% Project: AKKCT (Aircraft Kintetic Kill Countermeasures Technology)
```

```
% Last Updated: 31 OCT 95
```

```
%
```

```
% Function: This function divides two inputs, u(1) & u(2). If the result is
```

```
%      infinity or NaN (Not a number), zero is returned.
```

```
%*****
```

```
x=u(1)/u(2);
```

```
if isnan(x)==1 | isinf(x)==1
```

```
    h=0;
```

```
else
```

```
    h=x;
```

```
end
```

```

function r=exppos(u)

%*****
% exppos.m
% Used in BLOCK:Expendable
%
% Authors: Capt. Joel Hagan & Capt Brian Peterson, USAF
%         GSE-95D Air Force Institute of Technology
% Language: Matlab
% Project: AKKCT (Aircraft Kintetic Kill Countermeasures Technology)
% Last Updated: 14 SEP 95
%
% Function: This function return the position and velocity of the
%           expendable during the time between launch and when it goes
%           operational (if statement #1) and during the time it is
%           operational (if statement #2). It does so by interpolating
%           from the global look-up tables (exppvy and exppvyopr)
%           generated in lchtraj.m and gtoptraj.m
%*****

%used in BLOCK: Expendable

%u1=operational flag (-1 before operational
%       1 while operational
%       `100 afterwards)
%u2=launch flag -1 before launch 1 after
%u3=time
%u4-6= last position change due to wash noise (x,y,z)
%u7-9=noise wash standard deviation;
%u10=wash noise duration
global exppvxopr exppvyopr exppvzopr
global exppvx exppvy exppvz lchtime

r=[0 0 0 0 0 0 0 0 0];

time=u(3);

if ((time>=lchtime) & (time<=(lchtime+u(10))))
    noiseadd=[u(7)*randn u(8)*randn u(9)*randn];
else
    noiseadd=[0 0 0];
end;
r(7)=u(4)+noiseadd(1);
r(8)=u(5)+noiseadd(2);
r(9)=u(6)+noiseadd(3);

if (u(1)<0)& (u(2)>0) %between launch and when it goes operational
r(1)=interp1(exppvx(1,:),exppvx(2,:),time)+r(7);
r(2)=interp1(exppvx(1,:),exppvx(3,:),time);
r(3)=interp1(exppvy(1,:),exppvy(2,:),time)+r(8);
r(4)=interp1(exppvy(1,:),exppvy(3,:),time);
r(5)=interp1(exppvz(1,:),exppvz(2,:),time)+r(9);
r(6)=interp1(exppvz(1,:),exppvz(3,:),time);
elseif (u(1)>0)& (u(2)>0) % for duration of when it is operational

```

```
r(1)=interp1(exppvxopr(1,:),exppvxopr(2,:),time);  
r(2)=interp1(exppvxopr(1,:),exppvxopr(3,:),time);  
r(3)=interp1(exppvyopr(1,:),exppvyopr(2,:),time);  
r(4)=interp1(exppvyopr(1,:),exppvyopr(3,:),time);  
r(5)=interp1(exppvzopr(1,:),exppvzopr(2,:),time);  
r(6)=interp1(exppvzopr(1,:),exppvzopr(3,:),time);  
end;
```



```

function r=lnchtraj(u)
%*****
% launchtraj.m
% Used in BLOCK:Launch
%
% Authors: Capt. Joel Hagan & Capt Brian Peterson, USAF
%         GSE-95D Air Force Institute of Technology
% Language: Matlab
% Project: AKKCT (Aircraft Kintetic Kill Countermeasures Technology)
% Last Updated: 14 SEP 95
%
% Function: This function calculates the trajectory and velocity of the
%           expendable when it is launched and is still in the launch canister.
%           Once the global time reaches
%           the launch time, the position and velocity of the aircraft
%           are used to calculate the trajectory for the expendable using the
%           expendable characteristics. This is done using ODE23 in the simulation
%           so again, a global variable (onceitl) is used to prevent the calculation
%           from happening twice. The results are stored in global variables
%           exppvx,exppvy,exppvz. No noise is entered into the
%           expendable trajectory in this function. A flag is set for each
%           expendable from -1 to 1 when the expendable is launched.
%
%*****

```

```

global lnchtime;

```

```

%u1=time;
%u2=distance check between missile and AC
%u3=xac
%u4=yac
%u5=zac
%u6=xvac
%u7=yvac
%u8=Phi_Angle
%u9=Theta_Angle
%u10=time_to_target
%u11=acmtheta
%u12=acmphl
%u13=Quadrant launch
%u14=tracker
%u15=Tduration
%u16=R_Thrust
%u17=lethaldist
%u18=muzzle_vel
%u19=operational time feedback
%u20=flag feedback
%u21=launchtime feedback
%u22=detecttime
%u23=computation and slew delays

%r1=oper_time
%r2=flag
%r3=launchtime;
global exppvx exppvy exppvz

```

```

global onceitl;
xacl=u(3);
yacl=u(4);
zacl=u(5);
zvacl=u(6);
xvacl=u(7);
Phi_Angle=u(8)/57.3;
Theta_Angle=u(9)/57.3;
time_to_target=u(10);
thetamissile_at_launch=u(11);
phimissile_at_launch=u(12);
tracker=u(14);
Tduration=u(15);
R_Thrust=u(16);
lethaldist=u(17);
muzzle_vel=u(18);
detect_time=u(22);
delays=u(23);

launch_time=.001*(round(u(1)/.001));
r(1)=u(19);
r(2)=u(20);
r(3)=u(21);

if (((u(2)==0)&(tracker==1)) | ((u(13)>=launch_time)&(tracker==0))) & (u(20)==-
1)&(launch_time>=(detect_time+delays))) &(onceitl==1)
r(2)=1;
r(3)=launch_time;
Inchtime=launch_time;
if tracker==1
    %Add time required for expendable to get from launcher to target to the global
    %time at which launch occurs in order to get time at which expendable is operational
    opertime=time_to_target+launch_time;
else
    % only have quadrant detection
    if (thetamissile_at_launch>=0) & (thetamissile_at_launch<(90/57.3))
        opertime=launch_time+.144;
    else
        opertime=launch_time+.143;
    end
end;
r(1)=.001*round(opertime/.001);
end;

if (((u(2)==0)&(tracker==1)) | ((u(13)>=launch_time)&(tracker==0))) & (u(20)==-
1)&(launch_time>=(detect_time+delays))) &(onceitl==0)

onceitl=1;

launch_time
%Calculate Launch Angle if there is a tracker on-board the A/C
if tracker==1

```

```

%Add time required for expendable to get from launcher to target to the global
%time at which launch occurs in order to get time at which expendable is operational
opertime=time_to_target+launch_time;

%Calculate coordinates in space you wish to hit

x_wish_hit=xacl+lethaldist*sin(phimissile_at_launch)*cos(thetamissile_at_launch);
y_wish_hit=yacl+lethaldist*sin(phimissile_at_launch)*sin(thetamissile_at_launch);
z_wish_hit=zacl+lethaldist*cos(phimissile_at_launch);
else
% only have quadrant detection
if (thetamissile_at_launch>=0) & (thetamissile_at_launch< (90/57.3))
Phi_Angle=(93.12/57.3);
Theta_Angle=(45/57.3);
opertime=launch_time+.144;
else
Phi_Angle=(93.12/57.3);
Theta_Angle=(135/57.3);
opertime=launch_time+.143;
end
end

%Determine A/C position at which expendable detection occurs

launchx=xacl;
launchy=yacl;
launchz=zacl;

%Determine A/C velocity at which expendable launch occurs

launchvx=xvacl;
launchvz=zvacl;

%Determine position and velocity of expendable from time of
%launch to some future time. Said future time should be
%after the expected time of missile intercept by expendable
%or missile intercept of aircraft.

%Determine X position of expendable
%Expendable under thrust
if Tduration~=0 & R_Thrust~=0;

[txyzT,pvxyzT]=ode23('dqxyzt',launch_time-.001,launch_time-.001+Tduration,[launchx launchvx launchy
0 launchz launchvz]);

sizepvxyzT=size(pvxyzT);

lastxT=pvxyzT(sizepvxyzT(1),1);
lastvxT=pvxyzT(sizepvxyzT(1),2);

lastyT=pvxyzT(sizepvxyzT(1),3);
lastvyT=pvxyzT(sizepvxyzT(1),4);

```

```

lastzT=pvxyzT(sizepvxyzT(1),5);
lastvzT=pvxyzT(sizepvxyzT(1),6);

lasttxyzT=max(txyzT);

%Determine if X, Y, or Z velocity after thrust is negative
%If X, Y, or Z velocity is negative, you will make it and
%and the initial position of the nonthrust phase positive.
%If X, Y, or Z velocity is positive already, this will simply
%multiply the initial position and velocity of the
%nonthrust phase by 1.
posnegx=sign(lastvxT);
lastxT=lastxT.*posnegx;
lastvxT=lastvxT.*posnegx;

posnegy=sign(lastvyT);
lastyT=lastyT.*posnegy;
lastvyT=lastvyT.*posnegy;

posnegz=sign(lastvzT);
lastzT=lastzT.*posnegz;
lastvzT=lastvzT.*posnegz;
end;

%Expendable without thrust
%Define variables in ODE23 integraton step below if there is no
%thrust on expendable after it is launched.
if Tduration==0 | R_Thrust==0;
    lasttxyzT=launch_time-.001;
    lastxT=launchx;
    lastyT=launchy;
    lastzT=launchz;

lastvxT=launchvx+muzzle_vel*sin(Phi_Angle)*cos(Theta_Angle);
lastvyT=muzzle_vel*sin(Phi_Angle)*sin(Theta_Angle);
lastvzT=launchvz+muzzle_vel*cos(Phi_Angle);

%Determine if X,Y, or Z velocity is negative. If so, make it and the initial
%position positive to afford proper integration.
posnegx=sign(lastvxT);
posnegy=sign(lastvyT);
posnegz=sign(lastvzT);

lastxT=lastxT.*posnegx;
lastvxT=lastvxT.*posnegx;

lastyT=lastyT.*posnegy;
lastvyT=lastvyT.*posnegy;

lastzT=lastzT.*posnegz;
lastvzT=lastvzT.*posnegz;

end;

[txyzNT,pvxyzNT]=ode23('dqxyz',lasttxyzT,lasttxyzT+.2,[lastxT,lastvxT,lastyT,lastvyT,lastzT,lastvzT]);

```

```

%Multiply position and velocity after thrust by posneg
%correction factor above to return position and velocity
%in the nonthrust phase back to their proper direction.
pvxyzNT(:,1)=pvxyzNT(:,1).*posnegx;
pvxyzNT(:,2)=pvxyzNT(:,2).*posnegx;

pvxyzNT(:,3)=pvxyzNT(:,3).*posnegy;
pvxyzNT(:,4)=pvxyzNT(:,4).*posnegy;

pvxyzNT(:,5)=pvxyzNT(:,5).*posnegz;
pvxyzNT(:,6)=pvxyzNT(:,6).*posnegz;

%If Thrust sphere has thrust, Remove repeated data from txNT and pvxNT data
if Tduration~=0 | R_Thrust~=0;
    txyzNT(1)=[];
    pvxyzNT(1,:)=[];
end

txyz=[txyzT;txyzNT];
pvxyz=[pvxyzT;pvxyzNT];

txyz=txyz';
pvxyz=pvxyz';

exppvz=[txyz;pvxyz(1:2,:)];
exppvz=[txyz;pvxyz(3:4,:)];
exppvz=[txyz;pvxyz(5:6,:)];

%

r(1)=round(opertime/.001)*.001;

end

```

```

function xdot=dqxyz(t,x)

%*****
% file: dqxyz.m
% Used in Inchtraj.m, Inchtram.m (ODE23)
%
% Authors: Capt. Joel Hagan & Capt Brian Peterson, USAF
%         GSE-95D Air Force Institute of Technology
% Language: Matlab
% Project: AKKCT (Aircraft Kintetic Kill Countermeasures Technology)
% Last Updated: 31 OCT 95
%
% Function: This function develops the dynamic equations for expendable
% position and velocity in the all directions between when
% it is launched from the aircraft and when it goes operational.
%*****

%x(1)=x initial position
%x(2)=x initial velocity
%x(3)=y initial position
%x(4)=y initial velocity
%x(5)=z initial position
%x(6)=z initial velocity

global CD_sphere S_sphere W_sphere Rho_ambient

xvel=x(2);
yvel=x(4);
zvel=x(6);

xvelocity_direction=sign(x(2));
yvelocity_direction=sign(x(4));
zvelocity_direction=sign(x(6));

%Calculate phi and theta angles of sphere's velocity vector
thetavel=atan2(yvel,xvel);
resultxyvel=(xvel^2+yvel^2)^.5;
phivel=atan2(resultxyvel,zvel);

%Calculate reference area of sphere perpendicular to the x,y, & z directions
Sx_sphere=S_sphere*sin(phivel)*cos(thetavel);
Sy_sphere=S_sphere*sin(phivel)*sin(thetavel);
Sz_sphere=S_sphere*cos(phivel);

%Calculate constants in x,y, & z differential equations below
constx=(CD_sphere*.5*Rho_ambient*Sx_sphere)/(W_sphere/32.2);
consty=(CD_sphere*.5*Rho_ambient*Sy_sphere)/(W_sphere/32.2);
constz=(CD_sphere*.5*Rho_ambient*Sz_sphere)/(W_sphere/32.2);

%Differential equation in x direction
xdot(1)=xvel;
xdot(2)=(-1)*xvelocity_direction*(constx.*xvel^2);

%Differential equation in y direction
xdot(3)=yvel;

```

```
xdot(4)=(-1)*yvelocity_direction*(consty.*yvel^2);
```

```
%Differential equation in z direction
```

```
xdot(5)=zvel;
```

```
xdot(6)=(-1)*zvelocity_direction*(constz.*zvel^2)-32.2;
```

```

function r=gtoptraj(u)

%*****
% gtoptraj.m
% Used in BLOCK:Go_operational
%
% Authors: Capt. Joel Hagan & Capt Brian Peterson, USAF
%         GSE-95D Air Force Institute of Technology
% Language: Matlab
% Project: AKKCT (Aircraft Kintetic Kill Countermeasures Technology)
% Last Updated: 14 SEP 95
%
% Function: This function calculates the trajectory and velocity of the
%           expendable once it is operational. Once the global time reaches
%           the operational time, the position and velocity of the expendable
%           are used to calculate the trajectory for the expendable using the new
%           expendable characteristics. This is done using ODE23 in the simulation
%           so again, a global variable (onceito) is used to prevent the calculation
%           from happening twice. The results are stored in global variables
%           expvxopr,exppvopr,exppvzopr. No noise is entered into the expendable
%           trajectory in this function.
%           A flag is set from -1 to 1 for each expendable when it goes
%           operational and from 1 to 100 when it is no longer operational.
%*****

%u1=time
%u2=operational time
%u3=exp x
%u4=exp vx
%u5=exp y
%u6=exp yv
%u7=exp z
%u8=exp zv
%u9=opertime_duration
%u10=flag

global expvxopr expvyopr expvzopr
global onceito

opertime=u(2);
oper_duration=u(9);

timer=.001*round(u(1)/.001);
r=u(10);
if timer==(0.001*round((opertime+oper_duration)/.001))
    r=100;
end;

if (timer==opertime) & (onceito==1)
    r=1;
end

```



```

if (timer==opertime) & (onceito==0)
onceito=1;
timer
operxexp=u(3);
opervxexp=u(4);
operyexp=u(5);
opervyexp=u(6);
operzexp=u(7);
opervzexp=u(8);

```

```

%Determine x, y, & z position and velocity of expendable after it is operational

```

```

%Determine if x, y, or z velocity after expendable is
%operational is negative
%If x,y, or z velocity is negative, you will make it
%and the initial position positive.
%If x, y, or z velocity is already positive, this will simply
%multiply the initial position and velocity of the by 1
posnegxopr=sign(opervxexp);
operxexp=operxexp.*posnegxopr;
opervxexp=opervxexp.*posnegxopr;

posnegyopr=sign(opervyexp);
operyexp=operyexp.*posnegyopr;
opervyexp=opervyexp.*posnegyopr;

posnegzopr=sign(opervzexp);
operzexp=operzexp.*posnegzopr;
opervzexp=opervzexp.*posnegzopr;

```

```

[txyz_opr,pvxyz_opr]=ode23('dqxyzopr',opertime-.001,opertime-
.001+oper_duration,[operxexp,opervxexp,operyexp,opervyexp,operzexp,opervzexp]);

```

```

%Multiply position and velocity after thrust by posneg
%correction factor above to return position and velocity
%in the nonthrust phase back to their proper direction.
pvxyz_opr(:,1)=pvxyz_opr(:,1).*posnegxopr;
pvxyz_opr(:,2)=pvxyz_opr(:,2).*posnegxopr;

pvxyz_opr(:,3)=pvxyz_opr(:,3).*posnegyopr;
pvxyz_opr(:,4)=pvxyz_opr(:,4).*posnegyopr;

pvxyz_opr(:,5)=pvxyz_opr(:,5).*posnegzopr;
pvxyz_opr(:,6)=pvxyz_opr(:,6).*posnegzopr;

```

```

%If integration routine is unable to converge resulting in the attempted
%integration time steps taken by ode23 converging to the same value, take all
%of the data after the time at which ode23 can't converge and throw it out.
%Any values matlab needs for a time after the data you threw out will be
%linearly extrapolated using the last two good data points
sizetxyz_opr=size(txyz_opr);
xyz=1;

```

```

while xyz<size_txyz_opr(1,1)-1;
    if abs(txyz_opr(xyz)-txyz_opr(xyz+1))<.00001;
        txyz_opr=txyz_opr(1:xyz);
        pvxyz_opr=pvxyz_opr(1:xyz,:);
        xyz=size_txyz_opr(1,1);
    end
xyz=xyz+1;
end

txyz_opr=txyz_opr';
pvxyz_opr=pvxyz_opr';
timesize=size(txyz_opr,2);
txyz_opr(timesize+1)=txyz_opr(timesize)+25;
pvxyz_opr(1:6,timesize+1)=pvxyz_opr(1:6,timesize);

exppvxopr=[txyz_opr;pvxyz_opr(1:2,:)];
exppvyopr=[txyz_opr;pvxyz_opr(3:4,:)];
exppvzopr=[txyz_opr;pvxyz_opr(5:6,:)];

end;

```

```

function xdot=dqxyzopr(t,x)

%*****
% file: dqxyzopr.m
% Used in gtoptraj.m, gtoptram.m (ODE23)
%
% Authors: Capt. Joel Hagan & Capt Brian Peterson, USAF
%         GSE-95D Air Force Institute of Technology
% Language: Matlab
% Project: AKKCT (Aircraft Kintetic Kill Countermeasures Technology)
% Last Updated: 31 OCT 95
%
% Function: This function develops the dynamic equations for expendable
% position and velocity in the all directions when it goes operational.
%*****

%x(1)=x initial position
%x(2)=x initial velocity
%x(3)=y initial position
%x(4)=y initial velocity
%x(5)=z initial position
%x(6)=z initial velocity

global CD_exp S_exp W_exp Rho_ambient

xvel=x(2);
yvel=x(4);
zvel=x(6);

xvelocity_direction=sign(x(2));
yvelocity_direction=sign(x(4));
zvelocity_direction=sign(x(6));

%Calculate phi and theta angles of operational expendable velocity vector
thetavel=atan2(yvel,xvel);
resultxyvel=sqrt(xvel*xvel+yvel*yvel);
phivel=atan2(resultxyvel,zvel);

%Calculate reference area of expendable perpendicular to the x,y, & z directions
Sx_exp=S_exp*sin(phivel)*cos(thetavel);
Sy_exp=S_exp*sin(phivel)*sin(thetavel);
Sz_exp=S_exp*cos(phivel);

%Calculate constants in x,y, & z differential equations below
constx=(CD_exp*.5*Rho_ambient*Sx_exp)/(W_exp/32.2);
consty=(CD_exp*.5*Rho_ambient*Sy_exp)/(W_exp/32.2);
constz=(CD_exp*.5*Rho_ambient*Sz_exp)/(W_exp/32.2);

%Differential equation in x direction
xdot(1)=xvel;
xdot(2)=(-1)*xvelocity_direction*(constx.*xvel*xvel);

%Differential equation in y direction
xdot(3)=yvel;

```

```
xdot(4)=(-1)*yvelocity_direction*(consty.*yvel*yvel);
```

```
%Differential equation in z direction
```

```
xdot(5)=zvel;
```

```
xdot(6)=(-1)*zvelocity_direction*(constz.*zvel*zvel)-32.2;
```

function h=mexphit(u)

```
%*****  
% mexphit.m  
% Used in BLOCKs:Expendable, Expendable1, Expendable2,  
%     Expendable3, Expendable4, Expendable5,  
%     Expendable6, Expendable7  
%  
% Authors: Capt. Joel Hagan & Capt Brian Peterson, USAF  
%     GSE-95D Air Force Institute of Technology  
% Language: Matlab  
% Project: AKKCT (Aircraft Kintetic Kill Countermeasures Technology)  
% Last Updated: 14 SEP 95  
%  
% Function: This function is used to determine if the missile hits  
%     and operational expendable. It uses the slant range between  
%     the missile and the expendable in comparison with the effective  
%     radius of the expendable. If the slanrange is less than the  
%     radius, it is considered a hit. The resultin PK (probability  
%     of Kill) is determined by how close the missile is to the  
%     center of the expendable. A PK of .1 indicates the missile  
%     hit the outer edge while a PK of 1 indicates the missile hit  
%     very close to the center.  
%     Since 3-D slanrange is used, it is theoretically possible  
%     for this function to register a hit when the missile would  
%     not hit the expendable in the real world. In one time  
%     period, the slant range between the missile and the  
%     center of the expendable could be less than the radius  
%     of the expendable if the expendable was directly in  
%     front of the missile. On the next time step, however,  
%     if the expendable was falling fast enough, it could be  
%     out of the path of the missile. This would require  
%     that the expendable was falling extremely fast, which  
%     is not the case with any of the expendables used in this  
%     simulation. Still, this must be kept in mind when developing  
%     other expendables.  
%     The simulation will end if the slanrange between the missile and  
%     the expendable begins to increase (the PK can never get better)  
%     or if the expendable exceeds its operational time while the missile  
%     is within range (again, the PK will not get any better).  
%     This must be kept in mind when analyzing the data for  
%     simulations with multiple expendables. The simulation will end  
%     when it achieves the highest PK it can for the first expendable  
%     it hits. This gives a deceiving PK since the missile may have hit  
%     other expendables and received a better PK had the simulation been  
%     allowed to progress.  
%*****  
  
%Calculates if expendable has gotten close enough to the  
%missile to justify a successful hit of the missile  
  
%u(1)=flag variable delayed one time step (see below)  
%u(2)=flag variable which is -1 before the expendable is operational  
% 1 while it is operational and 100 after it is operational
```

```

%u(3)=slant range between missile and expendable
%u(4)=radius from center of expendable in which expendable is effective
%u(5)=expendable type (1=net, baloon, or anything that has a definite
    %effective area. 2=grenade, "goop", or anything in which its
    %effectiveness decreases with increase in radius from expendable)
% NOT CURRENTLY USED
%u(6)=Missile expendable slant range delayed by one time step (.001 sec)

```

```

%Initially define probability of kill is zero and the kill flag
%to stop the acme simulation should allow the simulation to continue
kill=0;
PK=0;
slanrange=u(3);
slanrangelast=u(6);
operflag=u(2);
operflaglast=u(1);
eff_radius=u(4);

```

```

if (operflag>0) & (operflag<99) & slanrange<=eff_radius

```

```

    if slanrange<=.1*eff_radius;
        PK=1;
    elseif slanrange>.1*eff_radius & slanrange<=.2*eff_radius;
        PK=.9;
    elseif slanrange>.2*eff_radius & slanrange<=.3*eff_radius;
        PK=.8;
    elseif slanrange>.3*eff_radius & slanrange<=.4*eff_radius;
        PK=.7;
    elseif slanrange>.4*eff_radius & slanrange<=.5*eff_radius;
        PK=.6;
    elseif slanrange>.5*eff_radius & slanrange<=.6*eff_radius;
        PK=.5;
    elseif slanrange>.6*eff_radius & slanrange<=.7*eff_radius;
        PK=.4;
    elseif slanrange>.7*eff_radius & slanrange<=.8*eff_radius;
        PK=.35;
    elseif slanrange>.8*eff_radius & slanrange<=.9*eff_radius;
        PK=.3;
    elseif slanrange>.9*eff_radius & slanrange<=1*eff_radius;
        PK=.2;
    else
        PK=0;
    end;

```

```

end

```

```

%Determine if the expendable is moving away from the missile

```

```
if (slanrange-slantrangelast>0) & (operflag>0) & (operflag<99) &...  
  ((slanrange<=eff_radius)|(slantrangelast<=eff_radius))  
  kill=1;
```

```
end
```

```
if (operflag>99) & (operflaglast>1) & (operflaglast<99) & (slantrangelast<=eff_radius)  
  kill=1;  
end;
```

```
h=[PK kill];
```

```
function h=misslego(u)
```

```
%*****
```

```
% File: misslego.m
```

```
% Used in BLOCK: Missile_Control
```

```
%
```

```
% Authors: Capt. Joel Hagan & Capt Brian Peterson, USAF
```

```
% GSE-95D Air Force Institute of Technology
```

```
% Language: Matlab
```

```
% Project: AKKCT (Aircraft Kintetic Kill Countermeasures Technology)
```

```
% Last Updated: 31 OCT 95
```

```
%
```

```
% Function: This block is used to generated the missile velocity profile.
```

```
% The velocity profile for the missile was derived from a standard thrust profile for a shoulder
```

```
% launched missile: rise to 3600N in the first .6 seconds, maintain thrust until 2 seconds after launch, and
```

```
% fall to thrust needed to maintain constant velocity (1000N) until 8 seconds after launch.
```

```
% It was easiest to see the profile by typing 'for I=0:0.1:25
```

```
% p(I*10)=misslego([I I]);
```

```
% end'
```

```
% plot(p)'
```

```
% Once the time is greater than the shottime, the profile begins.
```

```
%*****
```

```
%u(1)=global time
```

```
%u(2)=shot time
```

```
shottime=u(2);
```

```
time=u(1);
```

```
inflection1=shottime+2; % in the velocity profile, this is the time  
% of the first inflection point
```

```
leveloff=shottime+3; % time when velocity levels off
```

```
endlevel=shottime+8; % time when thrust ends
```

```
inflection2=endlevel+1; % final inflection point in velocity profile
```

```
max=1450; % Maximum missile speed for simulation
```

```
nearzero=.01;
```

```
falsemax=max/(1-nearzero/2);
```

```
half=falsemax/2;
```

```
inflect2mag=1200;
```

```
decaytime=4;
```

```
if (time<shottime)
```

```
h=0;
```

```
elseif (time>=shottime) & (time<inflection1)
```

```
h=(exp((time-shottime)*log(half+1)/(inflection1-shottime))-1;
```

```
elseif (time>=inflection1) & (time<leveloff)
```

```
h=half+half*(1-exp((time-inflection1)*(log(nearzero))/(leveloff-inflection1)));
```

```
elseif (time>=leveloff) & (time<endlevel)
```

```
h=max;
```

```
elseif (time>=endlevel) & (time<inflection2)
```

```
h=max-(exp((time-endlevel)*log(max-inflect2mag+1)/(inflection2-endlevel)));
```

```
elseif (time>=inflection2)
```

```
h=inflect2mag-inflect2mag*(1-exp((time-inflection2)*log(nearzero)/decaytime));
```

```
end;
```



```

function r=relativeangle(u)
%*****
% File: relanglr.m
% Used in BLOCK: Missile_Control
%
% Authors: Capt. Joel Hagan & Capt Brian Peterson, USAF
%          GSE-95D Air Force Institute of Technology
% Language: Matlab
% Project: AKKCT (Aircraft Kintetic Kill Countermeasures Technology)
% Last Updated: 31 OCT 95
%
% Function: This block determines the angle between the missile and the
%          aircraft from the missile launch point in the plane formed by the
%          vectors to the missile and to the aircraft. Used for
%          line-of-sight control.
%
%*****
%u1=x position of a/c
%u2=y position of a/c
%u3=z position of a/c
%u4=x position of missile
%u5=y position of missile
%u6=z position of missile
denom=((sqrt(u(1)*u(1)+u(2)*u(2)+u(3)*u(3)))*...
      (sqrt(u(4)*u(4)+u(5)*u(5)+u(6)*u(6))));

if denom==0
    x=pi/2;
else
    x=acos((u(1)*u(4)+u(2)*u(5)+u(3)*u(6))./denom);
end
if isnan(x)==1 || isinf(x)==1
    r=0;
else
    r=x;
end

```

```
function t=testnan(u)
%*****
% File: testnan.m
% Used in BLOCK: Missile_Control
%
% Authors: Capt. Joel Hagan & Capt Brian Peterson, USAF
%          GSE-95D Air Force Institute of Technology
% Language: Matlab
% Project: AKKCT (Aircraft Kintetic Kill Countermeasures Technology)
% Last Updated: 31 OCT 95
%
% Function: this functio passes a number, unless it is Nan (not number)
%          or infinity in which case it returns a 0.
%
%*****
```

```
if isnan(u)==1 | isinf(u)==1 | u==0
    t=0;
else
    t=u;
end
```

```
function r=testzero(u)
%*****
% File: testzero.m
% Used in BLOCK: Missile_Control
%
% Authors: Capt. Joel Hagan & Capt Brian Peterson, USAF
%         GSE-95D Air Force Institute of Technology
% Language: Matlab
% Project: AKKCT (Aircraft Kintetic Kill Countermeasures Technology)
% Last Updated: 31 OCT 95
%
% Function: This function changes a zero to 1e-600 (to prevent a division by zero)
% and passes all other numbers
%
%*****
r=u(1);
if u(1)==0
    r=1e-600;
end;
```

```

function [ret,x0,str,ts,xts]=acmeblcm(t,x,u,flag);
%ACMEBLCM is the M-file description of the SIMULINK system named ACMEBLCM.
% The block-diagram can be displayed by typing: ACMEBLCM.
%
%
% SYS=ACMEBLCM(T,X,U,FLAG) returns depending on FLAG certain
% system values given time point, T, current state vector, X,
% and input vector, U.
% FLAG is used to indicate the type of output to be returned in SYS.
%
% Setting FLAG=1 causes ACMEBLCM to return state derivatives, FLAG=2
% discrete states, FLAG=3 system outputs and FLAG=4 next sample
% time. For more information and other options see SFUNC.
%
% Calling ACMEBLCM with a FLAG of zero:
% [SIZES]=ACMEBLCM([],[],[],0), returns a vector, SIZES, which
% contains the sizes of the state vector and other parameters.
% SIZES(1) number of states
% SIZES(2) number of discrete states
% SIZES(3) number of outputs
% SIZES(4) number of inputs
% SIZES(5) number of roots (currently unsupported)
% SIZES(6) direct feedthrough flag
% SIZES(7) number of sample times
%
% For the definition of other parameters in SIZES, see SFUNC.
% See also, TRIM, LINMOD, LINSIM, EULER, RK23, RK45, ADAMS, GEAR:

% Note: This M-file is only used for saving graphical information;
% after the model is loaded into memory an internal model
% representation is used.

% the system will take on the name of this mfile:
sys = mfilename;
new_system(sys)
simver(1.3)
if (0 == (nargin + nargout))
    set_param(sys,'Location',[4,42,628,468])
    open_system(sys)
end;
set_param(sys,'algorithm', 'Linear')
set_param(sys,'Start time', '0.0')
set_param(sys,'Stop time', '80')
set_param(sys,'Min step size', '0.001')
set_param(sys,'Max step size', '0.001')
set_param(sys,'Relative error','1e-3')
set_param(sys,'Return vars', '')

add_block('built-in/MATLAB Fcn',[sys,/, 'expos7.m'])
set_param([sys,/, 'expos7.m'],...
    'orientation',2,...
    'MATLAB Fcn','expos7',...
    'Output Width','9',...
    'position',[1800,960,1850,990])

add_block('built-in/Constant',[sys,/, ['Effective radius ',13,'of expendable7']])

```

```

set_param([sys, '/', ['Effective radius ', 13, 'of expendable7']],...
          'Value', 'expeff_radius(7)',...
          'position', [1605, 1180, 1685, 1200])

add_block('built-in/MATLAB Fcn', [sys, '/', 'expos6.m'])
set_param([sys, '/', 'expos6.m'],...
          'orientation', 2,...
          'MATLAB Fcn', 'expos6',...
          'Output Width', '9',...
          'position', [1320, 1060, 1370, 1090])

add_block('built-in/Stop Simulation', [sys, '/', ['Stop simulation', 13, 'if non-zero', 13, '_7']])
set_param([sys, '/', ['Stop simulation', 13, 'if non-zero', 13, '_7']],...
          'position', [2050, 1154, 2100, 1196])

add_block('built-in/To Workspace', [sys, '/', 'mexslanrange7'])
set_param([sys, '/', 'mexslanrange7'],...
          'mat-name', 'mexslanrange7',...
          'buffer', '1000000000',...
          'position', [1920, 1185, 2010, 1205])

add_block('built-in/To Workspace', [sys, '/', 'PK7'])
set_param([sys, '/', 'PK7'],...
          'mat-name', 'PK7',...
          'buffer', '1000000000',...
          'position', [1910, 1145, 1960, 1165])

add_block('built-in/To Workspace', [sys, '/', 'zexp7'])
set_param([sys, '/', 'zexp7'],...
          'mat-name', 'zexp7',...
          'buffer', '1000000000',...
          'position', [2045, 1095, 2095, 1115])

add_block('built-in/To Workspace', [sys, '/', 'yexp7'])
set_param([sys, '/', 'yexp7'],...
          'mat-name', 'yexp7',...
          'buffer', '1000000000',...
          'position', [1960, 1080, 2010, 1100])

add_block('built-in/To Workspace', [sys, '/', 'xexp7'])
set_param([sys, '/', 'xexp7'],...
          'mat-name', 'xexp7',...
          'buffer', '1000000000',...
          'position', [2015, 1055, 2065, 1075])

add_block('built-in/Stop Simulation', [sys, '/', ['Stop simulation', 13, 'if non-zero', 13, '_6']])
set_param([sys, '/', ['Stop simulation', 13, 'if non-zero', 13, '_6']],...
          'position', [1590, 1224, 1640, 1266])

add_block('built-in/To Workspace', [sys, '/', 'PK6'])
set_param([sys, '/', 'PK6'],...
          'mat-name', 'PK6',...
          'buffer', '1000000000',...
          'position', [1460, 1215, 1510, 1235])

```

```

add_block('built-in/To Workspace',[sys,/, 'mexslanrange6'])
set_param([sys,/, 'mexslanrange6'],...
    'mat-name','mexslanrange6',...
    'buffer','1000000000',...
    'position',[1460,1255,1550,1275])

add_block('built-in/To Workspace',[sys,/, 'zexp6'])
set_param([sys,/, 'zexp6'],...
    'mat-name','zexp6',...
    'buffer','1000000000',...
    'position',[1515,1175,1565,1195])

add_block('built-in/To Workspace',[sys,/, 'yexp6'])
set_param([sys,/, 'yexp6'],...
    'mat-name','yexp6',...
    'buffer','1000000000',...
    'position',[1465,1135,1515,1155])

add_block('built-in/To Workspace',[sys,/, 'xexp6'])
set_param([sys,/, 'xexp6'],...
    'mat-name','xexp6',...
    'buffer','1000000000',...
    'position',[1515,1115,1565,1135])

add_block('built-in/Constant',[sys,/, ['Effective radius ',13,'of expendable6']])
set_param([sys,/, ['Effective radius ',13,'of expendable6']],...
    'Value','expeff_radius(6)',...
    'position',[1095,1250,1190,1270])

add_block('built-in/Stop Simulation',[sys,/, ['Stop simulation',13,'if non-zero',13,'_5']])
set_param([sys,/, ['Stop simulation',13,'if non-zero',13,'_5']],...
    'position',[1020,1149,1070,1191])

add_block('built-in/To Workspace',[sys,/, 'mexslanrange5'])
set_param([sys,/, 'mexslanrange5'],...
    'mat-name','mexslanrange5',...
    'buffer','1000000000',...
    'position',[895,1180,985,1200])

add_block('built-in/To Workspace',[sys,/, 'PK5'])
set_param([sys,/, 'PK5'],...
    'mat-name','PK5',...
    'buffer','1000000000',...
    'position',[945,1140,995,1160])

add_block('built-in/To Workspace',[sys,/, 'zexp5'])
set_param([sys,/, 'zexp5'],...
    'mat-name','zexp5',...
    'buffer','1000000000',...
    'position',[980,1095,1030,1115])

add_block('built-in/To Workspace',[sys,/, 'yexp5'])
set_param([sys,/, 'yexp5'],...
    'mat-name','yexp5',...
    'buffer','1000000000',...

```

```

        'position',[925,1065,975,1085])

add_block('built-in/To Workspace',[sys,/, 'xexp5'])
set_param([sys,/, 'xexp5'],...
    'mat-name','xexp5',...
    'buffer','1000000000',...
    'position',[985,1045,1035,1065])

add_block('built-in/Constant',[sys,/, ['Effective radius',13,' of expendable5']]
set_param([sys,/, ['Effective radius',13,' of expendable5']],...
    'Value','expeff_radius(5)',...
    'position',[575,1174,675,1196])

add_block('built-in/MATLAB Fcn',[sys,/, 'expos5.m'])
set_param([sys,/, 'expos5.m'],...
    'orientation',2,...
    'MATLAB Fcn','expos5',...
    'Output Width','9',...
    'position',[775,965,825,995])

add_block('built-in/Constant',[sys,/, ['Effective radius ',13,' of expendable4']]
set_param([sys,/, ['Effective radius ',13,' of expendable4']],...
    'Value','expeff_radius(4)',...
    'position',[80,1145,175,1165])

add_block('built-in/Stop Simulation',[sys,/, ['Stop simulation',13,'if non-zero',13,'_4']]
set_param([sys,/, ['Stop simulation',13,'if non-zero',13,'_4']],...
    'position',[505,1119,555,1161])

add_block('built-in/To Workspace',[sys,/, 'mexslanrange4'])
set_param([sys,/, 'mexslanrange4'],...
    'mat-name','mexslanrange4',...
    'buffer','1000000000',...
    'position',[400,1150,490,1170])

add_block('built-in/To Workspace',[sys,/, 'PK4'])
set_param([sys,/, 'PK4'],...
    'mat-name','PK4',...
    'buffer','1000000000',...
    'position',[420,1110,470,1130])

add_block('built-in/To Workspace',[sys,/, 'zexp4'])
set_param([sys,/, 'zexp4'],...
    'mat-name','zexp4',...
    'buffer','1000000000',...
    'position',[490,1075,540,1095])

add_block('built-in/To Workspace',[sys,/, 'yexp4'])
set_param([sys,/, 'yexp4'],...
    'mat-name','yexp4',...
    'buffer','1000000000',...
    'position',[410,1050,460,1070])

add_block('built-in/To Workspace',[sys,/, 'xexp4'])
set_param([sys,/, 'xexp4'],...

```

```

        'mat-name','xexp4',...
        'buffer','1000000000',...
        'position',[455,1020,505,1040])

add_block('built-in/MATLAB Fcn',[sys,/, 'expos4.m'])
set_param([sys,/, 'expos4.m'],...
    'orientation',2,...
    'MATLAB Fcn','expos4',...
    'Output Width','9',...
    'position',[275,945,325,975])

% Subsystem 'Missilexyz'.

new_system([sys,/, 'Missilexyz'])
set_param([sys,/, 'Missilexyz'],'Location',[-19,139,1117,676])

add_block('built-in/Sum',[sys,/, 'Missilexyz/s1'])
set_param([sys,/, 'Missilexyz/s1'],...
    'inputs','+++',...
    'position',[325,252,345,288])

add_block('built-in/Fcn',[sys,/, 'Missilexyz/Fcn12'])
set_param([sys,/, 'Missilexyz/Fcn12'],...
    'Expr','sqrt(u[1])',...
    'position',[360,258,425,282])

add_block('built-in/Note',[sys,/, 'Missilexyz/alpha '])
set_param([sys,/, 'Missilexyz/alpha '],...
    'position',[592,195,597,200])

add_block('built-in/Note',[sys,/, 'Missilexyz/beta'])
set_param([sys,/, 'Missilexyz/beta'],...
    'position',[682,245,687,250])

add_block('built-in/Mux',[sys,/, 'Missilexyz/Mux3'])
set_param([sys,/, 'Missilexyz/Mux3'],...
    'inputs','2',...
    'position',[655,298,685,327])

add_block('built-in/MATLAB Fcn',[sys,/, 'Missilexyz/divplus.m'])
set_param([sys,/, 'Missilexyz/divplus.m'],...
    'MATLAB Fcn','divplus',...
    'Output Width','1',...
    'position',[715,300,765,330])

add_block('built-in/MATLAB Fcn',[sys,/, 'Missilexyz/divplus.m (2)'])
set_param([sys,/, 'Missilexyz/divplus.m (2)'],...
    'MATLAB Fcn','divplus',...
    'Output Width','1',...
    'position',[595,250,645,280])

add_block('built-in/Mux',[sys,/, 'Missilexyz/Mux2'])
set_param([sys,/, 'Missilexyz/Mux2'],...
    'inputs','2',...

```



```

        'position',[535,248,565,277])

add_block('built-in/Mux',[sys,/, 'Missilexyz/Mux1'])
set_param([sys,/, 'Missilexyz/Mux1'],...
    'inputs',2,...
    'position',[445,198,475,227])

add_block('built-in/Inport',[sys,/, 'Missilexyz/in_3'])
set_param([sys,/, 'Missilexyz/in_3'],...
    'Port','3',...
    'position',[495,355,515,375])

add_block('built-in/Product',[sys,/, 'Missilexyz/m11'])
set_param([sys,/, 'Missilexyz/m11'],...
    'position',[880,385,905,405])

add_block('built-in/Product',[sys,/, 'Missilexyz/m12'])
set_param([sys,/, 'Missilexyz/m12'],...
    'position',[905,305,930,325])

add_block('built-in/Product',[sys,/, 'Missilexyz/m13'])
set_param([sys,/, 'Missilexyz/m13'],...
    'position',[920,210,945,230])

add_block('built-in/Sum',[sys,/, 'Missilexyz/Sum7'])
set_param([sys,/, 'Missilexyz/Sum7'],...
    'position',[995,390,1015,410])

add_block('built-in/Product',[sys,/, 'Missilexyz/m16'])
set_param([sys,/, 'Missilexyz/m16'],...
    'position',[910,435,935,455])

add_block('built-in/MATLAB Fcn',[sys,/, 'Missilexyz/divplus.m(3)'])
set_param([sys,/, 'Missilexyz/divplus.m(3)'],...
    'MATLAB Fcn','divplus',...
    'Output Width','1',...
    'position',[535,200,585,230])

add_block('built-in/Sum',[sys,/, 'Missilexyz/Sum6'])
set_param([sys,/, 'Missilexyz/Sum6'],...
    'position',[1015,335,1035,355])

add_block('built-in/Product',[sys,/, 'Missilexyz/m15'])
set_param([sys,/, 'Missilexyz/m15'],...
    'position',[950,345,975,365])

add_block('built-in/To Workspace',[sys,/, 'Missilexyz/ym'])
set_param([sys,/, 'Missilexyz/ym'],...
    'mat-name','ym',...
    'buffer','1000000000',...
    'position',[1115,337,1165,353])

add_block('built-in/To Workspace',[sys,/, 'Missilexyz/zm'])
set_param([sys,/, 'Missilexyz/zm'],...
    'mat-name','zm',...

```

```

        'buffer','1000000000',...
        'position',[1125,392,1175,408])

add_block('built-in/Mux',[sys,/, 'Missilexyz/Mux19'])
set_param([sys,/, 'Missilexyz/Mux19'],...
    'orientation',3,...
    'inputs',3,...
    'position',[1052,45,1088,95])

add_block('built-in/Product',[sys,/, 'Missilexyz/m14'])
set_param([sys,/, 'Missilexyz/m14'],...
    'position',[925,265,950,285])

add_block('built-in/Sum',[sys,/, 'Missilexyz/Sum5'])
set_param([sys,/, 'Missilexyz/Sum5'],...
    'position',[985,235,1005,255])

add_block('built-in/To Workspace',[sys,/, 'Missilexyz/xm'])
set_param([sys,/, 'Missilexyz/xm'],...
    'mat-name','xm',...
    'buffer','1000000000',...
    'position',[1120,237,1170,253])

add_block('built-in/Outport',[sys,/, ['Missilexyz/Missile position',13,'(x,y,z)']]
set_param([sys,/, ['Missilexyz/Missile position',13,'(x,y,z)']],...
    'orientation',3,...
    'position',[1060,10,1080,30])

add_block('built-in/Inport',[sys,/, 'Missilexyz/in_2'])
set_param([sys,/, 'Missilexyz/in_2'],...
    'Port','2',...
    'position',[780,390,800,410])

add_block('built-in/Demux',[sys,/, 'Missilexyz/Demux4'])
set_param([sys,/, 'Missilexyz/Demux4'],...
    'outputs',3,...
    'position',[95,112,135,168])

add_block('built-in/Product',[sys,/, 'Missilexyz/m2'])
set_param([sys,/, 'Missilexyz/m2'],...
    'position',[245,285,270,305])

add_block('built-in/Inport',[sys,/, ['Missilexyz/AC position',13,'(x,y,z)']]
set_param([sys,/, ['Missilexyz/AC position',13,'(x,y,z)']],...
    'position',[40,130,60,150])

add_block('built-in/Product',[sys,/, 'Missilexyz/m1'])
set_param([sys,/, 'Missilexyz/m1'],...
    'position',[205,205,230,225])

add_block('built-in/Product',[sys,/, 'Missilexyz/m'])
set_param([sys,/, 'Missilexyz/m'],...
    'position',[205,260,230,280])

add_block('built-in/Note',[sys,/, 'Missilexyz/BLOCK: Missilexyz'])

```

```

set_param([sys,'','Missilexyz/BLOCK: Missilexyz'],...
           'position',[470,500,475,505])
add_line([sys,'','Missilexyz'],[935,315;957,315;957,340;1010,340])
add_line([sys,'','Missilexyz'],[590,215;915,215])
add_line([sys,'','Missilexyz'],[905,215;895,215;895,270;920,270])
add_line([sys,'','Missilexyz'],[140,160;147,160;147,290;240,290])
add_line([sys,'','Missilexyz'],[147,270;147,300;240,300])
add_line([sys,'','Missilexyz'],[140,140;167,140;167,265;200,265])
add_line([sys,'','Missilexyz'],[140,120;185,120;185,210;200,210])
add_line([sys,'','Missilexyz'],[1020,400;1120,400])
add_line([sys,'','Missilexyz'],[1020,400;1080,400;1080,100])
add_line([sys,'','Missilexyz'],[1010,245;1115,245])
add_line([sys,'','Missilexyz'],[1010,245;1060,245;1060,100])
add_line([sys,'','Missilexyz'],[1040,345;1110,345])
add_line([sys,'','Missilexyz'],[1040,345;1070,345;1070,100])
add_line([sys,'','Missilexyz'],[235,215;287,215;287,260;320,260])
add_line([sys,'','Missilexyz'],[275,295;287,295;287,280;320,280])
add_line([sys,'','Missilexyz'],[430,270;530,270])
add_line([sys,'','Missilexyz'],[430,270;467,270;467,320;650,320])
add_line([sys,'','Missilexyz'],[430,270;427,270;427,220;440,220])
add_line([sys,'','Missilexyz'],[350,270;355,270])
add_line([sys,'','Missilexyz'],[910,395;990,395])
add_line([sys,'','Missilexyz'],[940,445;960,445;960,405;990,405])
add_line([sys,'','Missilexyz'],[980,355;990,355;990,350;1010,350])
add_line([sys,'','Missilexyz'],[955,275;970,275;980,250])
add_line([sys,'','Missilexyz'],[950,220;967,220;967,240;980,240])
add_line([sys,'','Missilexyz'],[650,265;882,265;882,310;900,310])
add_line([sys,'','Missilexyz'],[690,315;710,315])
add_line([sys,'','Missilexyz'],[570,265;590,265])
add_line([sys,'','Missilexyz'],[480,215;530,215])
add_line([sys,'','Missilexyz'],[65,140;90,140])
add_line([sys,'','Missilexyz'],[1070,40;1070,35])
add_line([sys,'','Missilexyz'],[520,365;650,365;650,450;905,450])
add_line([sys,'','Missilexyz'],[520,365;840,365;840,360;945,360])
add_line([sys,'','Missilexyz'],[840,365;840,280;920,280])
add_line([sys,'','Missilexyz'],[770,315;815,315;815,390;875,390])
add_line([sys,'','Missilexyz'],[815,390;815,440;905,440])
add_line([sys,'','Missilexyz'],[147,300;155,300;155,325;510,325;510,305;650,305])
add_line([sys,'','Missilexyz'],[235,270;320,270])
add_line([sys,'','Missilexyz'],[185,210;185,220;200,220])
add_line([sys,'','Missilexyz'],[175,265;175,275;200,275])
add_line([sys,'','Missilexyz'],[167,240;455,240;455,255;530,255])
add_line([sys,'','Missilexyz'],[185,190;430,190;440,205])
add_line([sys,'','Missilexyz'],[805,400;875,400])
add_line([sys,'','Missilexyz'],[855,400;855,320;900,320])
add_line([sys,'','Missilexyz'],[855,320;855,225;915,225])
add_line([sys,'','Missilexyz'],[880,265;880,350;945,350])
set_param([sys,'','Missilexyz'],...
           'Mask Display','AC position (x,y,z)   \nsin pos   Missile (x,y,z)\ncos pos
)

% Finished composite block 'Missilexyz'.

set_param([sys,'','Missilexyz'],...

```

```
'position',[615,144,765,196])
```

```
% Subsystem 'Missile_Range'
```

```
new_system([sys,/, 'Missile_Range'])
```

```
set_param([sys,/, 'Missile_Range'], 'Location', [40,255,885,531])
```

```
add_block('built-in/Outport',[sys,/, 'Missile_Range/Missile Range'])
```

```
set_param([sys,/, 'Missile_Range/Missile Range'],...
```

```
'orientation',2,...
```

```
'position',[80,95,100,115])
```

```
add_block('built-in/To Workspace',[sys,/, 'Missile_Range/mrange'])
```

```
set_param([sys,/, 'Missile_Range/mrange'],...
```

```
'orientation',2,...
```

```
'mat-name','mrange'...
```

```
'buffer','1000000'...
```

```
'position',[70,137,120,153])
```

```
add_block('built-in/Inport',[sys,/, 'Missile_Range/Missile Position (x,y,z)'])
```

```
set_param([sys,/, 'Missile_Range/Missile Position (x,y,z)'],...
```

```
'orientation',2,...
```

```
'position',[645,90,665,110])
```

```
add_block('built-in/Product',[sys,/, 'Missile_Range/m8'])
```

```
set_param([sys,/, 'Missile_Range/m8'],...
```

```
'orientation',2,...
```

```
'position',[340,125,365,145])
```

```
add_block('built-in/Product',[sys,/, 'Missile_Range/m7'])
```

```
set_param([sys,/, 'Missile_Range/m7'],...
```

```
'orientation',2,...
```

```
'position',[385,95,410,115])
```

```
add_block('built-in/Sum',[sys,/, 'Missile_Range/Sum3'])
```

```
set_param([sys,/, 'Missile_Range/Sum3'],...
```

```
'orientation',2,...
```

```
'inputs','+++',...
```

```
'position',[270,87,290,123])
```

```
add_block('built-in/Product',[sys,/, 'Missile_Range/m6'])
```

```
set_param([sys,/, 'Missile_Range/m6'],...
```

```
'orientation',2,...
```

```
'position',[340,60,365,80])
```

```
add_block('built-in/Demux',[sys,/, 'Missile_Range/Demux7'])
```

```
set_param([sys,/, 'Missile_Range/Demux7'],...
```

```
'orientation',2,...
```

```
'outputs','3',...
```

```
'position',[505,83,545,117])
```

```
add_block('built-in/Fcn',[sys,/, 'Missile_Range/Fcn10'])
```

```
set_param([sys,/, 'Missile_Range/Fcn10'],...
```

```
'orientation',2,...
```

```

'Expr','sqrt(u[1]),...
'position',[145,91,230,119])

add_block('built-in/Note',[sys,/, 'Missile_Range/BLOCK: Missile_Range'])
set_param([sys,/, 'Missile_Range/BLOCK: Missile_Range'],...
'position',[365,205,370,210])
add_line([sys,/, 'Missile_Range'],[500,110;462,110;462,130;370,130])
add_line([sys,/, 'Missile_Range'],[407,130;407,140;370,140])
add_line([sys,/, 'Missile_Range'],[500,90;452.90;452,65;370,65])
add_line([sys,/, 'Missile_Range'],[387,65;387,75;370,75])
add_line([sys,/, 'Missile_Range'],[500,100;415,100])
add_line([sys,/, 'Missile_Range'],[447,100;447,110;415,110])
add_line([sys,/, 'Missile_Range'],[265,105;235,105])
add_line([sys,/, 'Missile_Range'],[335,70;307.70;295,95])
add_line([sys,/, 'Missile_Range'],[380,105;295,105])
add_line([sys,/, 'Missile_Range'],[335,135;307.135;295,115])
add_line([sys,/, 'Missile_Range'],[140,105;135,105;125,145])
add_line([sys,/, 'Missile_Range'],[640,100;550,100])
add_line([sys,/, 'Missile_Range'],[140,105;105,105])
set_param([sys,/, 'Missile_Range'],...
'Mask Display','\nMissile      Missile \nRange      position \n      (x,y,z)')

% Finished composite block 'Missile_Range'.

set_param([sys,/, 'Missile_Range'],...
'orientation',2,...
'position',[360,475,495,525])

add_block('built-in/Demux',[sys,/, 'Dem6'])
set_param([sys,/, 'Dem6'],...
'outputs',7,...
'position',[1455,880,1495,960])

add_block('built-in/Constant',[sys,/, 'expdelay'])
set_param([sys,/, 'expdelay'],...
'Value','expdelay',...
'position',[1015,850,1070,870])

% Subsystem 'Launch_multiple'.

new_system([sys,/, 'Launch_multiple'])
set_param([sys,/, 'Launch_multiple'], 'Location',[87,270,1098,834])

add_block('built-in/To Workspace',[sys,/, 'Launch_multiple/opertime'])
set_param([sys,/, 'Launch_multiple/opertime'],...
'mat-name','opertime',...
'buffer','1000000000',...
'position',[170,44,245,66])

add_block('built-in/Sum',[sys,/, 'Launch_multiple/s3'])
set_param([sys,/, 'Launch_multiple/s3'],...
'orientation',1,...
'position',[544,140,571,160])

```

```

add_block('built-in/Constant',[sys,/, 'Launch_multiple/Computation time required'])
set_param([sys,/, 'Launch_multiple/Computation time required'],...
    'Value','computation_time_required',...
    'position',[280,87,450,103])

add_block('built-in/Constant',[sys,/, 'Launch_multiple/Slew time required'])
set_param([sys,/, 'Launch_multiple/Slew time required'],...
    'Value','slew_time_required',...
    'position',[290,120,450,140])

add_block('built-in/Demux',[sys,/, 'Launch_multiple/Dem5'])
set_param([sys,/, 'Launch_multiple/Dem5'],...
    'orientation',2,...
    'outputs','15',...
    'position',[170,185,210,265])

add_block('built-in/Mux',[sys,/, 'Launch_multiple/Mux20'])
set_param([sys,/, 'Launch_multiple/Mux20'],...
    'orientation',3,...
    'inputs','7',...
    'position',[41,100,119,135])

add_block('built-in/Mux',[sys,/, 'Launch_multiple/Mux17'])
set_param([sys,/, 'Launch_multiple/Mux17'],...
    'orientation',2,...
    'inputs','11',...
    'position',[465,194,500,306])

add_block('built-in/MATLAB Fcn',[sys,/, ['Launch_multiple/Get
expendable',13,'launch',13,'trajectory',13,'Inchtram.m']])
set_param([sys,/, ['Launch_multiple/Get expendable',13,'launch',13,'trajectory',13,'Inchtram.m']],...
    'orientation',2,...
    'MATLAB Fcn','Inchtram',...
    'Output Width','15',...
    'position',[375,230,425,260])

add_block('built-in/Memory',[sys,/, ['Launch_multiple/',13,'Memory 2',13,'IC=[100(7)',13,'
100]']])
set_param([sys,/, ['Launch_multiple/',13,'Memory 2',13,'IC=[100(7)',13,'
1(7) 100]']],...
    'orientation',2,...
    'x0','[100 100 100 100 100 100 -1 -1 -1 -1 -1 -1 -1 100]',...
    'position',[285,230,325,260])

add_block('built-in/To Workspace',[sys,/, 'Launch_multiple/launch time'])
set_param([sys,/, 'Launch_multiple/launch time'],...
    'mat-name','launch_time',...
    'buffer','1000000000',...
    'position',[165,284,240,306])

add_block('built-in/Outport',[sys,/, 'Launch_multiple/Operational Times'])
set_param([sys,/, 'Launch_multiple/Operational Times'],...
    'orientation',3,...
    'position',[70,15,90,35])

```

```

add_block('built-in/Outport',[sys,/, 'Launch_multiple/Launch Flag 7'])
set_param([sys,/, 'Launch_multiple/Launch Flag 7'],...
    'orientation',2,...
    'Port','8',...
    'position',[40,465,60,485])

add_block('built-in/Outport',[sys,/, 'Launch_multiple/Launch Flag 5'])
set_param([sys,/, 'Launch_multiple/Launch Flag 5'],...
    'orientation',2,...
    'Port','6',...
    'position',[40,375,60,395])

add_block('built-in/Outport',[sys,/, 'Launch_multiple/Launch Flag 4'])
set_param([sys,/, 'Launch_multiple/Launch Flag 4'],...
    'orientation',2,...
    'Port','5',...
    'position',[40,335,60,355])

add_block('built-in/Outport',[sys,/, 'Launch_multiple/Launch Flag 6'])
set_param([sys,/, 'Launch_multiple/Launch Flag 6'],...
    'orientation',2,...
    'Port','7',...
    'position',[40,415,60,435])

add_block('built-in/Outport',[sys,/, 'Launch_multiple/Launch Flag 3'])
set_param([sys,/, 'Launch_multiple/Launch Flag 3'],...
    'orientation',2,...
    'Port','4',...
    'position',[40,295,60,315])

add_block('built-in/Outport',[sys,/, 'Launch_multiple/Launch Flag 2'])
set_param([sys,/, 'Launch_multiple/Launch Flag 2'],...
    'orientation',2,...
    'Port','3',...
    'position',[40,255,60,275])

add_block('built-in/Outport',[sys,/, 'Launch_multiple/Launch Flag 1'])
set_param([sys,/, 'Launch_multiple/Launch Flag 1'],...
    'orientation',2,...
    'Port','2',...
    'position',[40,215,60,235])

add_block('built-in/To Workspace',[sys,/, 'Launch_multiple/Quadrant launch time'])
set_param([sys,/, 'Launch_multiple/Quadrant launch time'],...
    'mat-name','quad_launch_time',...
    'buffer','1000000000',...
    'position',[705,340,785,360])

add_block('built-in/Inport',[sys,/, 'Launch_multiple/Time'])
set_param([sys,/, 'Launch_multiple/Time'],...
    'orientation',2,...
    'Port','3',...
    'position',[585,170,605,190])

add_block('built-in/Inport',[sys,/, 'Launch_multiple/Launch data'])

```

```

set_param([sys,'/','Launch_multiple/Launch data'],...
          'orientation',2,...
          'Port','7',...
          'position',[780,305,800,325])

add_block('built-in/Inport',[sys,'/','Launch_multiple/AC pos (x,y,z)'])
set_param([sys,'/','Launch_multiple/AC pos (x,y,z)'],...
          'orientation',2,...
          'Port','5',...
          'position',[785,205,805,225])

add_block('built-in/Inport',[sys,'/','Launch_multiple/Fire Flag'])
set_param([sys,'/','Launch_multiple/Fire Flag'],...
          'orientation',2,...
          'Port','4',...
          'position',[785,165,805,185])

add_block('built-in/Constant',[sys,'/','Launch_multiple/Detect time',13,'after launch'])
set_param([sys,'/','Launch_multiple/Detect time',13,'after launch'],...
          'Value','detectal',...
          'position',[730,25,810,45])

add_block('built-in/Constant',[sys,'/','Launch_multiple/Shot time ',13,'after T/O'])
set_param([sys,'/','Launch_multiple/Shot time ',13,'after T/O'],...
          'orientation',2,...
          'Value','shottime',...
          'position',[875,25,955,45])

add_block('built-in/Sum',[sys,'/','Launch_multiple/s2'])
set_param([sys,'/','Launch_multiple/s2'],...
          'orientation',1,...
          'position',[829,120,856,140])

add_block('built-in/Sum',[sys,'/','Launch_multiple/s2_'])
set_param([sys,'/','Launch_multiple/s2_'],...
          'orientation',2,...
          'inputs','++',...
          'position',[860,222,880,278])

add_block('built-in/Inport',[sys,'/','Launch_multiple/Quadrant time',13,'to target'])
set_param([sys,'/','Launch_multiple/Quadrant time',13,'to target'],...
          'orientation',2,...
          'position',[910,258,930,282])

add_block('built-in/Inport',[sys,'/','Launch_multiple/AC vel (z,x)'])
set_param([sys,'/','Launch_multiple/AC vel (z,x)'],...
          'orientation',2,...
          'Port','6',...
          'position',[680,215,700,235])

add_block('built-in/Inport',[sys,'/','Launch_multiple/Quadrant Launch',13,'Delay'])
set_param([sys,'/','Launch_multiple/Quadrant Launch',13,'Delay'],...
          'orientation',2,...
          'Port','2',...
          'position',[980,241,1005,259])

```



```

add_block('built-in/Inport',[sys,/, 'Launch_multiple/expdelay'])
set_param([sys,/, 'Launch_multiple/expdelay'],...
          'orientation',2,...
          'Port','8',...
          'position',[530,365,550,385])

add_block('built-in/Constant',[sys,/, 'Launch_multiple/muzzle velocity'])
set_param([sys,/, 'Launch_multiple/muzzle velocity'],...
          'Value','muzzle_vel',...
          'position',[350,505,405,525])

add_block('built-in/Mux',[sys,/, 'Launch_multiple/Mux18'])
set_param([sys,/, 'Launch_multiple/Mux18'],...
          'inputs','5',...
          'position',[460,402,490,528])

add_block('built-in/Constant',[sys,/, 'Launch_multiple/Tduration'])
set_param([sys,/, 'Launch_multiple/Tduration'],...
          'Value','Tduration',...
          'position',[285,430,340,450])

add_block('built-in/Constant',[sys,/, 'Launch_multiple/tracker'])
set_param([sys,/, 'Launch_multiple/tracker'],...
          'Value','tracker',...
          'position',[355,405,410,425])

add_block('built-in/Constant',[sys,/, 'Launch_multiple/R_Thrust'])
set_param([sys,/, 'Launch_multiple/R_Thrust'],...
          'Value','R_Thrust',...
          'position',[350,455,405,475])

add_block('built-in/Constant',[sys,/, 'Launch_multiple/lethaldist'])
set_param([sys,/, 'Launch_multiple/lethaldist'],...
          'Value','lethaldist',...
          'position',[290,480,345,500])

add_block('built-in/Note',[sys,/, 'Launch_multiple/BLOCK: Launch_multiple'])
set_param([sys,/, 'Launch_multiple/BLOCK: Launch_multiple'],...
          'position',[690,510,695,515])
add_line([sys,/, 'Launch_multiple'],[845,145;845,170;895,170;885,230])
add_line([sys,/, 'Launch_multiple'],[80,95;80,40])
add_line([sys,/, 'Launch_multiple'],[80,50;80,55;165,55])
add_line([sys,/, 'Launch_multiple'],[560,165;560,300;505,300])
add_line([sys,/, 'Launch_multiple'],[455,95;565,95;565,135])
add_line([sys,/, 'Launch_multiple'],[455,130;465,130;465,120;550,120;550,135])
add_line([sys,/, 'Launch_multiple'],[845,145;845,280;505,280])
add_line([sys,/, 'Launch_multiple'],[815,35;835,35;835,115])
add_line([sys,/, 'Launch_multiple'],[870,35;850,35;850,115])
add_line([sys,/, 'Launch_multiple'],[855,250;505,250])
add_line([sys,/, 'Launch_multiple'],[690,250;700,350])
add_line([sys,/, 'Launch_multiple'],[165,220;110,220;110,140])
add_line([sys,/, 'Launch_multiple'],[165,215;100,215;100,140])
add_line([sys,/, 'Launch_multiple'],[165,210;90,210;90,140])
add_line([sys,/, 'Launch_multiple'],[165,205;80,205;80,140])

```

```

add_line([sys,'','Launch_multiple'],[165,200;70,200;70,140])
add_line([sys,'','Launch_multiple'],[165,195;60,195;60,140])
add_line([sys,'','Launch_multiple'],[165,190;50,190;50,140])
add_line([sys,'','Launch_multiple'],[165,260;150,260;160,295])
add_line([sys,'','Launch_multiple'],[410,515;455,515])
add_line([sys,'','Launch_multiple'],[280,245;260,225;215,225])
add_line([sys,'','Launch_multiple'],[260,225;260,325;555,325;555,270;505,270])
add_line([sys,'','Launch_multiple'],[370,245;330,245])
add_line([sys,'','Launch_multiple'],[350,490;455,490])
add_line([sys,'','Launch_multiple'],[410,465;455,465])
add_line([sys,'','Launch_multiple'],[495,465;575,465;575,260;505,260])
add_line([sys,'','Launch_multiple'],[345,440;455,440])
add_line([sys,'','Launch_multiple'],[415,415;455,415])
add_line([sys,'','Launch_multiple'],[460,250;430,245])
add_line([sys,'','Launch_multiple'],[905,270;885,270])
add_line([sys,'','Launch_multiple'],[975,250;885,250])
add_line([sys,'','Launch_multiple'],[780,175;625,175;625,210;505,210])
add_line([sys,'','Launch_multiple'],[780,215;610,215;610,220;505,220])
add_line([sys,'','Launch_multiple'],[165,225;65,225])
add_line([sys,'','Launch_multiple'],[675,225;625,225;625,230;505,230])
add_line([sys,'','Launch_multiple'],[165,230;95,230;95,265;65,265])
add_line([sys,'','Launch_multiple'],[165,235;100,235;100,305;65,305])
add_line([sys,'','Launch_multiple'],[775,315;600,315;600,240;505,240])
add_line([sys,'','Launch_multiple'],[165,240;110,240;110,345;65,345])
add_line([sys,'','Launch_multiple'],[165,245;120,245;120,385;65,385])
add_line([sys,'','Launch_multiple'],[165,250;130,250;130,425;65,425])
add_line([sys,'','Launch_multiple'],[165,255;140,255;140,475;65,475])
add_line([sys,'','Launch_multiple'],[525,375;525,290;505,290])
add_line([sys,'','Launch_multiple'],[580,180;575,180;575,200;505,200])
set_param([sys,'','Launch_multiple'],...
    'Mask Display','Quad time- Operational\n to-target
Launch\ndelay      Flag 1\nGlobal Time  Flag 2\n\nFire Flag  Times\nQuad launch
\n (x,y,z)         \nAC Velocity  Flag 5 \n (z,x)  Flag 3\n\nAC position  Flag 4
6\nExpendable     \n delay      Flag 7')

```

% Finished composite block 'Launch_multiple'.

```

set_param([sys,'','Launch_multiple'],...
    'position',[1115,704,1260,876])

add_block('built-in/Constant',[sys,'','Effective radius ',13,'of expendable3'])
set_param([sys,'','Effective radius ',13,'of expendable3'],...
    'Value','expeff_radius(3)',...
    'position',[1375,705,1470,725])

```

% Subsystem 'Go_operational_multiple'.

```

new_system([sys,'','Go_operational_multiple'])
set_param([sys,'','Go_operational_multiple'],'Location',[333,661,1058,882])

add_block('built-in/Memory',[sys,'','Go_operational_multiple/Memory',13,'IC: [-1 -1 -1 -1 -1 -1 -1 -1]'])
set_param([sys,'','Go_operational_multiple/Memory',13,'IC: [-1 -1 -1 -1 -1 -1 -1 -1]'],...
    'x0',[-1 -1 -1 -1 -1 -1 -1 -1],...)

```

```

'position',[115,150,155,180])

add_block('built-in/MATLAB Fcn',[sys,/,['Go_operational_multiple/Get
expendable',13,'operational',13,'trajectory',13,'gtoptram.m']])
set_param([sys,/,['Go_operational_multiple/Get
expendable',13,'operational',13,'trajectory',13,'gtoptram.m']],...
'orientation',2,...
'MATLAB Fcn','gtoptram',...
'Output Width','7',...
'position',[110,55,160,85])

add_block('built-in/Constant',[sys,/, 'Go_operational_multiple/oper_duration'])
set_param([sys,/, 'Go_operational_multiple/oper_duration'],...
'orientation',2,...
'Value','oper_duration',...
'position',[280,75,375,95])

add_block('built-in/Mux',[sys,/, 'Go_operational_multiple/Mux7'])
set_param([sys,/, 'Go_operational_multiple/Mux7'],...
'orientation',2,...
'inputs','5',...
'position',[200,33,240,107])

add_block('built-in/Outport',[sys,/, 'Go_operational_multiple/out_1'])
set_param([sys,/, 'Go_operational_multiple/out_1'],...
'position',[420,155,440,175])

add_block('built-in/Inport',[sys,/, 'Go_operational_multiple/Time'])
set_param([sys,/, 'Go_operational_multiple/Time'],...
'orientation',2,...
'position',[330,15,350,35])

add_block('built-in/Note',[sys,/, 'Go_operational_multiple/BLOCK:Go_operational_multiple'])
set_param([sys,/, 'Go_operational_multiple/BLOCK:Go_operational_multiple'],...
'position',[540,125,545,130])

add_block('built-in/Inport',[sys,/, 'Go_operational_multiple/Operational Times'])
set_param([sys,/, 'Go_operational_multiple/Operational Times'],...
'orientation',2,...
'Port','2',...
'position',[515,45,535,65])

add_block('built-in/Inport',[sys,/, ['Go_operational_multiple/Expendable positions ',13, '& velocities']])
set_param([sys,/, ['Go_operational_multiple/Expendable positions ',13, '& velocities']],...
'orientation',2,...
'Port','3',...
'position',[435,60,455,80])

add_line([sys,/, 'Go_operational_multiple'],[160,165;415,165])
add_line([sys,/, 'Go_operational_multiple'],[270,165;270,100;245,100])
add_line([sys,/, 'Go_operational_multiple'],[275,85;245,85])
add_line([sys,/, 'Go_operational_multiple'],[195,70;165,70])
add_line([sys,/, 'Go_operational_multiple'],[105,70;70,70;70,165;110,165])
add_line([sys,/, 'Go_operational_multiple'],[325,25;290,25;290,40;245,40])
add_line([sys,/, 'Go_operational_multiple'],[510,55;245,55])
add_line([sys,/, 'Go_operational_multiple'],[430,70;245,70])

```

```

set_param([sys,'Go_operational_multiple'],...
           'Mask Display',Time           \n\nOperational Oper.\n Times   Flags \n
Expendable \n position/velocities ')

```

```

% Finished composite block 'Go_operational_multiple'.

```

```

set_param([sys,'Go_operational_multiple'],...
           'position',[1315,885,1435,955])

```

```

% Subsystem 'Launch_data'.

```

```

new_system([sys,'Launch_data'])
set_param([sys,'Launch_data'],'Location',[245,305,985,640])

```

```

add_block('built-in/Look Up Table',[sys,'Launch_data/Look-up',13,'IN:Launch theta',13,'OUT:Launch
Phi'])

```

```

set_param([sys,'Launch_data/Look-up',13,'IN:Launch theta',13,'OUT:Launch Phi'],...
           'orientation',2,...
           'Input_Values','theta_launch_lu',...
           'Output_Values','phi_launch_lu',...
           'position',[230,128,260,152])

```

```

add_block('built-in/Product',[sys,'Launch_data/m21'])

```

```

set_param([sys,'Launch_data/m21'],...
           'orientation',2,...
           'position',[390,130,415,150])

```

```

add_block('built-in/Constant',[sys,'Launch_data/57.3'])

```

```

set_param([sys,'Launch_data/57.3'],...
           'orientation',2,...
           'Value','57.3',...
           'position',[450,140,490,160])

```

```

add_block('built-in/Sum',[sys,'Launch_data/Sum24'])

```

```

set_param([sys,'Launch_data/Sum24'],...
           'orientation',2,...
           'position',[505,123,530,147])

```

```

add_block('built-in/Inport',[sys,'Launch_data/Missile theta'])

```

```

set_param([sys,'Launch_data/Missile theta'],...
           'orientation',2,...
           'position',[755,235,775,255])

```

```

add_block('built-in/Product',[sys,'Launch_data/m23'])

```

```

set_param([sys,'Launch_data/m23'],...
           'orientation',2,...
           'position',[585,130,610,150])

```

```

add_block('built-in/Constant',[sys,'Launch_data/trackerstd'])

```

```

set_param([sys,'Launch_data/trackerstd'],...
           'orientation',2,...
           'Value','trackerstd',...
           'position',[805,134,870,156])

```

```

add_block('built-in/Inport',[sys,/, 'Launch_data/Missile phi'])
set_param([sys,/, 'Launch_data/Missile phi'],...
    'orientation',2,...
    'Port',2,...
    'position',[515,250,535,270])

add_block('built-in/Look Up Table',[sys,/, ['Launch_data/Look-up',13,'IN: Missile
Theta',13,'OUT:Launch',13,' theta']])
set_param([sys,/, ['Launch_data/Look-up',13,'IN: Missile Theta',13,'OUT:Launch',13,' theta']],...
    'orientation',2,...
    'Input_Values',theta_missile_lu',...
    'Output_Values',theta_launch_lu',...
    'position',[335,128,365,152])

add_block('built-in/Outport',[sys,/, 'Launch_data/Launch data'])
set_param([sys,/, 'Launch_data/Launch data'],...
    'orientation',2,...
    'position',[50,220,70,240])

add_block('built-in/Mux',[sys,/, 'Launch_data/Mux14'])
set_param([sys,/, 'Launch_data/Mux14'],...
    'orientation',2,...
    'inputs',5',...
    'position',[120,196,150,264])

add_block('built-in/Look Up Table',[sys,/, ['Launch_data/Look-up',13,'IN:Missile Theta',13,'OUT: Time-to-
target']])
set_param([sys,/, ['Launch_data/Look-up',13,'IN:Missile Theta',13,'OUT: Time-to-target']],...
    'orientation',2,...
    'Input_Values',theta_missile_lu',...
    'Output_Values',time_lu',...
    'position',[605,168,635,192])

add_block('built-in/White Noise',[sys,/, ['Launch_data/White Noise',13,'6']])
set_param([sys,/, ['Launch_data/White Noise',13,'6']],...
    'orientation',2,...
    'Seed',noiseseed(6)',...
    'position',[775,70,795,90])

% Subsystem ['Launch_data/hold5',13,'sample=.25'].

new_system([sys,/, ['Launch_data/hold5',13,'sample=.25']])
set_param([sys,/, ['Launch_data/hold5',13,'sample=.25']], 'Location',[511,151,915,322])

add_block('built-in/Zero-Order Hold',[sys,/, ['Launch_data/hold5',13,'sample=.25/Zero-Order',13,'Hold']])
set_param([sys,/, ['Launch_data/hold5',13,'sample=.25/Zero-Order',13,'Hold']],...
    'Sample time','Ts',...
    'position',[100,29,135,61])

add_block('built-in/Gain',[sys,/, ['Launch_data/hold5',13,'sample=.25/Gain']])
set_param([sys,/, ['Launch_data/hold5',13,'sample=.25/Gain']],...
    'Gain','1/Ts',...
    'position',[285,33,325,77])

```

```

add_block('built-in/Integrator',[sys,/,['Launch_data/hold5',13,'sample=.25/Integrator']])
set_param([sys,/,['Launch_data/hold5',13,'sample=.25/Integrator']],...
    'position',[235,42,260,68])

add_block('built-in/Sum',[sys,/,['Launch_data/hold5',13,'sample=.25/Sum']])
set_param([sys,/,['Launch_data/hold5',13,'sample=.25/Sum']],...
    'inputs','+',...
    'position',[190,37,210,68])

add_block('built-in/Unit Delay',[sys,/,['Launch_data/hold5',13,'sample=.25/Unit Delay']])
set_param([sys,/,['Launch_data/hold5',13,'sample=.25/Unit Delay']],...
    'Sample time','Ts',...
    'position',[90,93,140,117])

add_block('built-in/Inport',[sys,/,['Launch_data/hold5',13,'sample=.25/input']])
set_param([sys,/,['Launch_data/hold5',13,'sample=.25/input']],...
    'position',[25,35,45,55])

add_block('built-in/Outport',[sys,/,['Launch_data/hold5',13,'sample=.25/output']])
set_param([sys,/,['Launch_data/hold5',13,'sample=.25/output']],...
    'position',[345,45,365,65])
add_line([sys,/,['Launch_data/hold5',13,'sample=.25']], [330,55;340,55])
add_line([sys,/,['Launch_data/hold5',13,'sample=.25']], [265,55;280,55])
add_line([sys,/,['Launch_data/hold5',13,'sample=.25']], [215,55;230,55])
add_line([sys,/,['Launch_data/hold5',13,'sample=.25']], [145,105;165,105;165,60;185,60])
add_line([sys,/,['Launch_data/hold5',13,'sample=.25']], [140,45;185,45])
add_line([sys,/,['Launch_data/hold5',13,'sample=.25']], [50,45;95,45])
add_line([sys,/,['Launch_data/hold5',13,'sample=.25']], [65,45;65,105;85,105])
set_param([sys,/,['Launch_data/hold5',13,'sample=.25']],...
    'Mask Display','plot(0,0,100,100,[90,70,50,30,10],[60,40,80,30,20])',...
    'Mask Type','First-Order Hold',...
    'Mask Dialogue','First-Order Hold|Sample Time:')
set_param([sys,/,['Launch_data/hold5',13,'sample=.25']],...
    'Mask Translate','Ts=@ 1;',...
    'Mask Help','Implements a First-Order sample-and-hold latch operating at the sampling
interval you specify.',...
    'Mask Entries','.25V')

% Finished composite block ['Launch_data/hold5',13,'sample=.25'].

set_param([sys,/,['Launch_data/hold5',13,'sample=.25']],...
    'orientation',2,...
    'position',[695,64,730,96])

add_block('built-in/Note',[sys,/,['Launch_data/BLOCK: Launch_data']])
set_param([sys,/,['Launch_data/BLOCK: Launch_data']],...
    'position',[255,310,260,315])
add_line([sys,/,['Launch_data']], [750,245;155,245])
add_line([sys,/,['Launch_data']], [685,245;685,180;640,180])
add_line([sys,/,['Launch_data']], [600,180;540,180;540,230;155,230])
add_line([sys,/,['Launch_data']], [560,245;560,130;535,130])
add_line([sys,/,['Launch_data']], [580,140;535,140])
add_line([sys,/,['Launch_data']], [500,135;420,135])

```

```

add_line([sys,'','Launch_data'],[690,80;655,80;655,135;615,135])
add_line([sys,'','Launch_data'],[800,145;615,145])
add_line([sys,'','Launch_data'],[770,80;735,80])
add_line([sys,'','Launch_data'],[330,140;295,140;295,215;155,215])
add_line([sys,'','Launch_data'],[225,140;180,140;180,200;155,200])
add_line([sys,'','Launch_data'],[445,150;435,145;420,145])
add_line([sys,'','Launch_data'],[385,140;370,140])
add_line([sys,'','Launch_data'],[330,140;265,140])
add_line([sys,'','Launch_data'],[115,230;75,230])
add_line([sys,'','Launch_data'],[510,260;155,260])
set_param([sys,'','Launch_data'],...
    'Mask Display','Missile theta \n Launch data\nMissile phi ')

```

```

% Finished composite block 'Launch_data'.

```

```

set_param([sys,'','Launch_data'],...
    'position',[880,813,980,862])

```

```

% Subsystem 'MissileVel_Seen_by_A/C'.

```

```

new_system([sys,'','MissileVel_Seen_by_A/C'])
set_param([sys,'','MissileVel_Seen_by_A/C'],'Location',[52,105,1178,931])

```

```

add_block('built-in/Demux',[sys,'','MissileVel_Seen_by_A/C/D5'])
set_param([sys,'','MissileVel_Seen_by_A/C/D5'],...
    'orientation',1,...
    'outputs','2',...
    'position',[785,70,825,110])

```

```

add_block('built-in/Inport',[sys,'','MissileVel_Seen_by_A/C/AC velocity (z,x)'])
set_param([sys,'','MissileVel_Seen_by_A/C/AC velocity (z,x)'],...
    'orientation',1,...
    'position',[795,35,815,55])

```

```

add_block('built-in/Derivative',[sys,'','MissileVel_Seen_by_A/C/dt2'])
set_param([sys,'','MissileVel_Seen_by_A/C/dt2'],...
    'orientation',2,...
    'position',[645,175,675,195])

```

```

add_block('built-in/Derivative',[sys,'','MissileVel_Seen_by_A/C/dt'])
set_param([sys,'','MissileVel_Seen_by_A/C/dt'],...
    'orientation',2,...
    'position',[745,220,775,240])

```

```

add_block('built-in/Sum',[sys,'','MissileVel_Seen_by_A/C/Sum20'])
set_param([sys,'','MissileVel_Seen_by_A/C/Sum20'],...
    'orientation',2,...
    'inputs','+','-,...
    'position',[630,210,650,230])

```

```

add_block('built-in/Product',[sys,'','MissileVel_Seen_by_A/C/m27'])
set_param([sys,'','MissileVel_Seen_by_A/C/m27'],...
    'orientation',2,...

```

```

'position',[570,205,595,225])

add_block('built-in/Product',[sys,/, 'MissileVel_Seen_by_A//C/m28'])
set_param([sys,/, 'MissileVel_Seen_by_A//C/m28'],...
'orientation',2,...
'position',[565,170,590,190])

add_block('built-in/Derivative',[sys,/, 'MissileVel_Seen_by_A//C/dt1'])
set_param([sys,/, 'MissileVel_Seen_by_A//C/dt1'],...
'orientation',2,...
'position',[670,145,700,165])

add_block('built-in/Demux',[sys,/, 'MissileVel_Seen_by_A//C/Demux6'])
set_param([sys,/, 'MissileVel_Seen_by_A//C/Demux6'],...
'orientation',2,...
'outputs','3',...
'position',[830,243,870,297])

add_block('built-in/Sum',[sys,/, 'MissileVel_Seen_by_A//C/Sum22'])
set_param([sys,/, 'MissileVel_Seen_by_A//C/Sum22'],...
'orientation',2,...
'inputs','+',...
'position',[615,125,635,145])

add_block('built-in/Product',[sys,/, 'MissileVel_Seen_by_A//C/m26'])
set_param([sys,/, 'MissileVel_Seen_by_A//C/m26'],...
'orientation',2,...
'position',[555,125,580,145])

add_block('built-in/Sum',[sys,/, 'MissileVel_Seen_by_A//C/Sum21'])
set_param([sys,/, 'MissileVel_Seen_by_A//C/Sum21'],...
'orientation',2,...
'inputs','+++',...
'position',[490,127,510,163])

add_block('built-in/Outport',[sys,/, ['MissileVel_Seen_by_A//C/Relative velocity ',13,'w// noise']])
set_param([sys,/, ['MissileVel_Seen_by_A//C/Relative velocity ',13,'w// noise']],...
'orientation',2,...
'position',[60,165,80,185])

add_block('built-in/Fcn',[sys,/, 'MissileVel_Seen_by_A//C/Fcn15'])
set_param([sys,/, 'MissileVel_Seen_by_A//C/Fcn15'],...
'orientation',2,...
'Expr','sqrt(u[1])',...
'position',[365,133,450,157])

add_block('built-in/Product',[sys,/, 'MissileVel_Seen_by_A//C/m25'])
set_param([sys,/, 'MissileVel_Seen_by_A//C/m25'],...
'orientation',2,...
'position',[200,190,225,210])

add_block('built-in/Constant',[sys,/, 'MissileVel_Seen_by_A//C/missilelevelstd'])
set_param([sys,/, 'MissileVel_Seen_by_A//C/missilelevelstd'],...
'orientation',2,...
'Value','missilelevelstd',...

```



```

        'position',[265,205,345,225])

add_block('built-in/Sum',[sys,/,['MissileVel_Seen_by_A//C/Sum25']]
set_param([sys,/,['MissileVel_Seen_by_A//C/Sum25']],...
    'orientation',2,...
    'position',[140,157,160,193])

add_block('built-in/Inport',[sys,/,['MissileVel_Seen_by_A//C/Missile position ',13,'(x,y,z)']]
set_param([sys,/,['MissileVel_Seen_by_A//C/Missile position ',13,'(x,y,z)']],...
    'orientation',2,...
    'Port',2,...
    'position',[930,260,950,280])

% Subsystem ['MissileVel_Seen_by_A//C/hold7',13,'sample:.25'].

new_system([sys,/,['MissileVel_Seen_by_A//C/hold7',13,'sample:.25']])
set_param([sys,/,['MissileVel_Seen_by_A//C/hold7',13,'sample:.25']], 'Location',[511,151,915,322])

add_block('built-in/Zero-Order Hold',[sys,/,['MissileVel_Seen_by_A//C/hold7',13,'sample:.25/Zero-Order',13,'Hold']]
set_param([sys,/,['MissileVel_Seen_by_A//C/hold7',13,'sample:.25/Zero-Order',13,'Hold']],...
    'Sample time','Ts',...
    'position',[100,29,135,61])

add_block('built-in/Gain',[sys,/,['MissileVel_Seen_by_A//C/hold7',13,'sample:.25/Gain']]
set_param([sys,/,['MissileVel_Seen_by_A//C/hold7',13,'sample:.25/Gain']],...
    'Gain','1/Ts',...
    'position',[285,33,325,77])

add_block('built-in/Integrator',[sys,/,['MissileVel_Seen_by_A//C/hold7',13,'sample:.25/Integrator']]
set_param([sys,/,['MissileVel_Seen_by_A//C/hold7',13,'sample:.25/Integrator']],...
    'position',[235,42,260,68])

add_block('built-in/Sum',[sys,/,['MissileVel_Seen_by_A//C/hold7',13,'sample:.25/Sum']]
set_param([sys,/,['MissileVel_Seen_by_A//C/hold7',13,'sample:.25/Sum']],...
    'inputs','+',...
    'position',[190,37,210,68])

add_block('built-in/Unit Delay',[sys,/,['MissileVel_Seen_by_A//C/hold7',13,'sample:.25/Unit Delay']]
set_param([sys,/,['MissileVel_Seen_by_A//C/hold7',13,'sample:.25/Unit Delay']],...
    'Sample time','Ts',...
    'position',[90,93,140,117])

add_block('built-in/Inport',[sys,/,['MissileVel_Seen_by_A//C/hold7',13,'sample:.25/input']]
set_param([sys,/,['MissileVel_Seen_by_A//C/hold7',13,'sample:.25/input']],...
    'position',[25,35,45,55])

add_block('built-in/Outport',[sys,/,['MissileVel_Seen_by_A//C/hold7',13,'sample:.25/output']]
set_param([sys,/,['MissileVel_Seen_by_A//C/hold7',13,'sample:.25/output']],...
    'position',[345,45,365,65])
add_line([sys,/,['MissileVel_Seen_by_A//C/hold7',13,'sample:.25']], [330,55;340,55])
add_line([sys,/,['MissileVel_Seen_by_A//C/hold7',13,'sample:.25']], [265,55;280,55])
add_line([sys,/,['MissileVel_Seen_by_A//C/hold7',13,'sample:.25']], [215,55;230,55])
add_line([sys,/,['MissileVel_Seen_by_A//C/hold7',13,'sample:.25']], [145,105;165,105;165,60;185,60])

```

```

add_line([sys,'/','MissileVel_Seen_by_A//C/hold7',13,'sample:.25'],[140,45;185,45])
add_line([sys,'/','MissileVel_Seen_by_A//C/hold7',13,'sample:.25'],[50,45;95,45])
add_line([sys,'/','MissileVel_Seen_by_A//C/hold7',13,'sample:.25'],[65,45;65,105;85,105])
set_param([sys,'/','MissileVel_Seen_by_A//C/hold7',13,'sample:.25'],...
    'Mask Display','plot(0,0,100,100,[90,70,50,30,10],[60,40,80,30,20]),...
    'Mask Type','First-Order Hold',...
    'Mask Dialogue','First-Order Hold|Sample Time:')
set_param([sys,'/','MissileVel_Seen_by_A//C/hold7',13,'sample:.25'],...
    'Mask Translate','Ts=@ 1;',...
    'Mask Help','Implements a First-Order sample-and-hold latch operating at the sampling
interval you specify.',...
    'Mask Entries','.25V')

```

```

% Finished composite block ['MissileVel_Seen_by_A//C/hold7',13,'sample:.25'].

```

```

set_param([sys,'/','MissileVel_Seen_by_A//C/hold7',13,'sample:.25'],...
    'orientation',2,...
    'position',[365,179,400,211])

```

```

add_block('built-in/White Noise',[sys,'/','MissileVel_Seen_by_A//C/White Noise',13,'8'])
set_param([sys,'/','MissileVel_Seen_by_A//C/White Noise',13,'8'],...
    'orientation',2,...
    'Seed','noiseseed(8)',...
    'position',[445,185,465,205])

```

```

add_block('built-in/Note',[sys,'/','MissileVel_Seen_by_A//C/BLOCK: MissileVel_Seen_by_A//C'])
set_param([sys,'/','MissileVel_Seen_by_A//C/BLOCK: MissileVel_Seen_by_A//C'],...
    'position',[315,300,320,305])
add_line([sys,'/','MissileVel_Seen_by_A//C'],[825,250;792,250;792,230;780,230])
add_line([sys,'/','MissileVel_Seen_by_A//C'],[825,270;717,270;717,185;680,185])
add_line([sys,'/','MissileVel_Seen_by_A//C'],[825,290;722,290;722,155;705,155])
add_line([sys,'/','MissileVel_Seen_by_A//C'],[360,145;302,145;302,165;165,165])
add_line([sys,'/','MissileVel_Seen_by_A//C'],[195,200;187,200;187,185;165,185])
add_line([sys,'/','MissileVel_Seen_by_A//C'],[360,195;230,195])
add_line([sys,'/','MissileVel_Seen_by_A//C'],[260,215;257,205;230,205])
add_line([sys,'/','MissileVel_Seen_by_A//C'],[440,195;405,195])
add_line([sys,'/','MissileVel_Seen_by_A//C'],[640,185;595,185])
add_line([sys,'/','MissileVel_Seen_by_A//C'],[630,185;630,175;595,175])
add_line([sys,'/','MissileVel_Seen_by_A//C'],[485,145;455,145])
add_line([sys,'/','MissileVel_Seen_by_A//C'],[625,220;625,210;600,210])
add_line([sys,'/','MissileVel_Seen_by_A//C'],[625,220;600,220])
add_line([sys,'/','MissileVel_Seen_by_A//C'],[740,230;732,225;655,225])
add_line([sys,'/','MissileVel_Seen_by_A//C'],[665,155;640,140])
add_line([sys,'/','MissileVel_Seen_by_A//C'],[815,115;815,215;655,215])
add_line([sys,'/','MissileVel_Seen_by_A//C'],[795,115;795,130;640,130])
add_line([sys,'/','MissileVel_Seen_by_A//C'],[560,180;547,180;547,145;515,145])
add_line([sys,'/','MissileVel_Seen_by_A//C'],[565,215;525,215;515,155])
add_line([sys,'/','MissileVel_Seen_by_A//C'],[550,135;515,135])
add_line([sys,'/','MissileVel_Seen_by_A//C'],[610,135;585,130])
add_line([sys,'/','MissileVel_Seen_by_A//C'],[610,135;585,140])
add_line([sys,'/','MissileVel_Seen_by_A//C'],[805,60;805,65])
add_line([sys,'/','MissileVel_Seen_by_A//C'],[135,175;85,175])
add_line([sys,'/','MissileVel_Seen_by_A//C'],[925,270;875,270])
set_param([sys,'/','MissileVel_Seen_by_A//C'],...

```

'Mask Display','AC velocity (z,x) \n Relative Velocity\nMissile pos (x,y,z) ')

% Finished composite block 'MissileVel_Seen_by_A/C'.

```
set_param([sys, '/', 'MissileVel_Seen_by_A/C'], ...
    'position', [655, 291, 790, 349])
```

```
add_block('built-in/Mux', [sys, '/', 'Mux11'])
set_param([sys, '/', 'Mux11'], ...
    'orientation', 3, ...
    'inputs', 5, ...
    'position', [1171, 970, 1269, 990])
```

```
add_block('built-in/Mux', [sys, '/', 'Mux10'])
set_param([sys, '/', 'Mux10'], ...
    'inputs', 3, ...
    'position', [2040, 435, 2070, 465])
```

% Subsystem 'HitCheck'.

```
new_system([sys, '/', 'HitCheck'])
set_param([sys, '/', 'HitCheck'], 'Location', [166, 239, 818, 574])
```

```
add_block('built-in/To Workspace', [sys, '/', 'HitCheck/Left inboard engine'])
set_param([sys, '/', 'HitCheck/Left inboard engine'], ...
    'orientation', 2, ...
    'mat-name', 'srllie', ...
    'buffer', '1000000000', ...
    'position', [340, 137, 390, 153])
```

```
add_block('built-in/To Workspace', [sys, '/', 'HitCheck/Right inboard engine'])
set_param([sys, '/', 'HitCheck/Right inboard engine'], ...
    'orientation', 2, ...
    'mat-name', 'srrie', ...
    'buffer', '1000000000', ...
    'position', [310, 107, 360, 123])
```

```
add_block('built-in/To Workspace', [sys, '/', 'HitCheck/Left outboard engine'])
set_param([sys, '/', 'HitCheck/Left outboard engine'], ...
    'orientation', 2, ...
    'mat-name', 'srloe', ...
    'buffer', '1000000000', ...
    'position', [280, 77, 330, 93])
```

```
add_block('built-in/To Workspace', [sys, '/', 'HitCheck/Cockpit'])
set_param([sys, '/', 'HitCheck/Cockpit'], ...
    'mat-name', 'srcp', ...
    'buffer', '1000000000', ...
    'position', [520, 107, 570, 123])
```

```
add_block('built-in/Demux', [sys, '/', 'HitCheck/Demux3'])
set_param([sys, '/', 'HitCheck/Demux3'], ...
    'outputs', 8, ...
```

```

        'position',[400,167,440,253])

add_block('built-in/MATLAB Fcn',[sys,/, 'HitCheck/ifend.m'])
set_param([sys,/, 'HitCheck/ifend.m'],...
    'MATLAB Fcn','ifend',...
    'Output Width','8',...
    'position',[330,195,380,225])

add_block('built-in/Mux',[sys,/, 'HitCheck/Mux4'])
set_param([sys,/, 'HitCheck/Mux4'],...
    'inputs','3',...
    'position',[275,170,305,230])

add_block('built-in/Constant',[sys,/, 'HitCheck/Lethal distance'])
set_param([sys,/, 'HitCheck/Lethal distance'],...
    'Value','lethaldist',...
    'position',[155,189,225,211])

add_block('built-in/Inport',[sys,/, 'HitCheck/AC position (x,y,z)'])
set_param([sys,/, 'HitCheck/AC position (x,y,z)'],...
    'position',[55,170,75,190])

add_block('built-in/Inport',[sys,/, 'HitCheck/Missile position (x,y,z)'])
set_param([sys,/, 'HitCheck/Missile position (x,y,z)'],...
    'Port','2',...
    'position',[70,220,90,240])

add_block('built-in/Stop Simulation',[sys,/, ['HitCheck/Stop simulation',13,'if non-zero',13,]])
set_param([sys,/, ['HitCheck/Stop simulation',13,'if non-zero',13,]],...
    'position',[520,224,570,266])

add_block('built-in/To Workspace',[sys,/, 'HitCheck/Right outboard engine'])
set_param([sys,/, 'HitCheck/Right outboard engine'],...
    'mat-name','srroe',...
    'buffer','1000000000',...
    'position',[525,77,575,93])

add_block('built-in/To Workspace',[sys,/, 'HitCheck/Empenage'])
set_param([sys,/, 'HitCheck/Empenage'],...
    'mat-name','sremp',...
    'buffer','1000000000',...
    'position',[520,137,570,153])

add_block('built-in/To Workspace',[sys,/, 'HitCheck/Center of gravity'])
set_param([sys,/, 'HitCheck/Center of gravity'],...
    'mat-name','srcg',...
    'buffer','1000000000',...
    'position',[525,167,575,183])

add_block('built-in/Note',[sys,/, 'HitCheck/BLOCK: HitCheck'])
set_param([sys,/, 'HitCheck/BLOCK: HitCheck'],...
    'position',[205,290,210,295])
add_line([sys,/, 'HitCheck'],[230,200;270,200])
add_line([sys,/, 'HitCheck'],[445,245;515,245])
add_line([sys,/, 'HitCheck'],[445,235;475,235;475,175;520,175])

```

```

add_line([sys,/, 'HitCheck'],[445,225;470,225;470,145;515,145])
add_line([sys,/, 'HitCheck'],[445,215;465,215;465,115;515,115])
add_line([sys,/, 'HitCheck'],[445,205;460,205;460,85;520,85])
add_line([sys,/, 'HitCheck'],[445,195;455,195;455,85;335,85])
add_line([sys,/, 'HitCheck'],[445,185;450,185;450,115;365,115])
add_line([sys,/, 'HitCheck'],[445,175;445,145;395,145])
add_line([sys,/, 'HitCheck'],[385,210;395,210])
add_line([sys,/, 'HitCheck'],[310,200;325,210])
add_line([sys,/, 'HitCheck'],[80,180;270,180])
add_line([sys,/, 'HitCheck'],[95,230;245,230;245,220;270,220])
set_param([sys,/, 'HitCheck'],...
    'Mask Display','AC position (x,y,z) \n\nMissile position (x,y,z)')

```

% Finished composite block 'HitCheck'.

```

set_param([sys,/, 'HitCheck'],...
    'position',[855,107,995,158])

```

% Subsystem 'Relative_angles_and_range'.

```

new_system([sys,/, 'Relative_angles_and_range'])
set_param([sys,/, 'Relative_angles_and_range'],'Location',[45,102,620,460])

```

```

add_block('built-in/To Workspace',[sys,/, 'Relative_angles_and_range/A//C - missile slant range'])
set_param([sys,/, 'Relative_angles_and_range/A//C - missile slant range'],...
    'mat-name','amslanrange'...
    'buffer','1000000000'...
    'position',[425,213,545,227])

```

```

add_block('built-in/Outport',[sys,/, 'Relative_angles_and_range/Missile phi'])
set_param([sys,/, 'Relative_angles_and_range/Missile phi'],...
    'position',[455,85,475,105])

```

```

add_block('built-in/Inport',[sys,/, 'Relative_angles_and_range/AC position (x,y,z)'])
set_param([sys,/, 'Relative_angles_and_range/AC position (x,y,z)'],...
    'Port','2'...
    'position',[65,140,85,160])

```

```

add_block('built-in/Inport',[sys,/, 'Relative_angles_and_range/Missile Position (x,y,z)'])
set_param([sys,/, 'Relative_angles_and_range/Missile Position (x,y,z)'],...
    'position',[65,105,85,125])

```

```

add_block('built-in/Mux',[sys,/, 'Relative_angles_and_range/Mux6'])
set_param([sys,/, 'Relative_angles_and_range/Mux6'],...
    'inputs','2'...
    'position',[140,99,170,166])

```

```

add_block('built-in/MATLAB Fcn',[sys,/, ['Relative_angles_and_range/Relative Angle',13,'between
A//C',13,'and missile',13,'acmangle.m']])
set_param([sys,/, ['Relative_angles_and_range/Relative Angle',13,'between A//C',13,'and
missile',13,'acmangle.m']],...
    'MATLAB Fcn','acmangle'...
    'Output Width','3'...

```

```

        'position',[200,120,250,150])

add_block('built-in/Demux',[sys,/, 'Relative_angles_and_range/Demux'])
set_param([sys,/, 'Relative_angles_and_range/Demux'],...
    'outputs',3,...
    'position',[280,119,320,151])

add_block('built-in/Outport',[sys,/, 'Relative_angles_and_range/Missile theta'])
set_param([sys,/, 'Relative_angles_and_range/Missile theta'],...
    'Port',2,...
    'position',[485,125,505,145])

add_block('built-in/Outport',[sys,/, 'Relative_angles_and_range/Missile Range'])
set_param([sys,/, 'Relative_angles_and_range/Missile Range'],...
    'Port',3,...
    'position',[420,250,440,270])

add_block('built-in/To Workspace',[sys,/, ['Relative_angles_and_range/Theta angle between ',13, ' A/C and
missile']])
set_param([sys,/, ['Relative_angles_and_range/Theta angle between ',13, ' A/C and missile']],...
    'mat-name','acmtheta_end'...
    'buffer','1000000000'...
    'position',[455,165,580,185])

add_block('built-in/To Workspace',[sys,/, ['Relative_angles_and_range/Phi angle between',13,'A/C and
missile ']])
set_param([sys,/, ['Relative_angles_and_range/Phi angle between',13,'A/C and missile '']],...
    'mat-name','acmphi_end'...
    'buffer','1000000000'...
    'position',[400,41,480,59])

add_block('built-in/Note',[sys,/, 'Relative_angles_and_range/BLOCK: Relative_angles_and_range'])
set_param([sys,/, 'Relative_angles_and_range/BLOCK: Relative_angles_and_range'],...
    'position',[220,300,225,305])
add_line([sys,/, 'Relative_angles_and_range'],[325,135;405,135;405,175;450,175])
add_line([sys,/, 'Relative_angles_and_range'],[325,145;365,145;365,220;420,220])
add_line([sys,/, 'Relative_angles_and_range'],[325,125;365,125;365,50;395,50])
add_line([sys,/, 'Relative_angles_and_range'],[255,135;275,135])
add_line([sys,/, 'Relative_angles_and_range'],[175,135;195,135])
add_line([sys,/, 'Relative_angles_and_range'],[90,115;135,115])
add_line([sys,/, 'Relative_angles_and_range'],[325,125;365,125;365,95;450,95])
add_line([sys,/, 'Relative_angles_and_range'],[325,135;480,135])
add_line([sys,/, 'Relative_angles_and_range'],[325,145;365,145;365,260;415,260])
add_line([sys,/, 'Relative_angles_and_range'],[90,150;135,150])
set_param([sys,/, 'Relative_angles_and_range'],...
    'Mask Display',' Missile Missile Phi\nPosition (x,y,z) \n
Missile Theta\n AC position Missile \n (x,y,z) Range (rel)')

% Finished composite block 'Relative_angles_and_range'.

set_param([sys,/, 'Relative_angles_and_range'],...
    'position',[620,606,785,664])

```

```

% Subsystem 'Missile_Control'.

new_system([sys, '/', 'Missile_Control'])
set_param([sys, '/', 'Missile_Control'], 'Location', [32, 291, 1142, 851])

add_block('built-in/Inport', [sys, '/', ['Missile_Control/Missile ', 13, 'position', 13, '(x,y,z)']]
set_param([sys, '/', ['Missile_Control/Missile ', 13, 'position', 13, '(x,y,z)']], ...
    'Port', '3', ...
    'position', [105, 155, 125, 175])

add_block('built-in/Inport', [sys, '/', 'Missile_Control/mrange'])
set_param([sys, '/', 'Missile_Control/mrange'], ...
    'Port', '2', ...
    'position', [305, 50, 325, 70])

add_block('built-in/Product', [sys, '/', 'Missile_Control/m3'])
set_param([sys, '/', 'Missile_Control/m3'], ...
    'position', [385, 135, 410, 155])

add_block('built-in/Fcn', [sys, '/', 'Missile_Control/Fcn11'])
set_param([sys, '/', 'Missile_Control/Fcn11'], ...
    'Expr', '(1/u[1])', ...
    'position', [520, 80, 560, 100])

add_block('built-in/MATLAB Fcn', [sys, '/', 'Missile_Control/testnan.m'])
set_param([sys, '/', 'Missile_Control/testnan.m'], ...
    'MATLAB Fcn', 'testnan', ...
    'position', [590, 75, 640, 105])

add_block('built-in/Sum', [sys, '/', 'Missile_Control/Sum4'])
set_param([sys, '/', 'Missile_Control/Sum4'], ...
    'inputs', '+-+', ...
    'position', [335, 142, 355, 178])

add_block('built-in/Mux', [sys, '/', 'Missile_Control/Mux'])
set_param([sys, '/', 'Missile_Control/Mux'], ...
    'inputs', '2', ...
    'position', [155, 114, 185, 181])

add_block('built-in/MATLAB Fcn', [sys, '/', 'Missile_Control/testzero.m'])
set_param([sys, '/', 'Missile_Control/testzero.m'], ...
    'MATLAB Fcn', 'testzero', ...
    'position', [415, 75, 465, 105])

add_block('built-in/Gain', [sys, '/', 'Missile_Control/Gain1'])
set_param([sys, '/', 'Missile_Control/Gain1'], ...
    'Gain', '.5', ...
    'position', [425, 135, 445, 155])

add_block('built-in/Transfer Fcn', [sys, '/', ['Missile_Control/Transfer ', 13, 'Fcn9']]
set_param([sys, '/', ['Missile_Control/Transfer ', 13, 'Fcn9']], ...
    'Numerator', '[1 2 1]', ...
    'Denominator', '[.0999 .632 1]', ...
    'position', [460, 126, 580, 164])

```

```

add_block('built-in/Inport',[sys,/,['Missile_Control/AC position (x,y,z)']]
set_param([sys,/,['Missile_Control/AC position (x,y,z)'],...
    'position',[60,120,80,140])

add_block('built-in/Product',[sys,/,['Missile_Control/mn4']]
set_param([sys,/,['Missile_Control/mn4'],...
    'position',[270,250,295,270])

add_block('built-in/White Noise',[sys,/,['Missile_Control/White Noise',13,'4']]
set_param([sys,/,['Missile_Control/White Noise',13,'4'],...
    'Seed',noiseseed(4),...
    'position',[150,245,170,265])

% Subsystem ['Missile_Control/hold4',13,'sample=.1'].

new_system([sys,/,['Missile_Control/hold4',13,'sample=.1']])
set_param([sys,/,['Missile_Control/hold4',13,'sample=.1'],'Location',[511,151,915,322])

add_block('built-in/Outport',[sys,/,['Missile_Control/hold4',13,'sample=.1/output']]
set_param([sys,/,['Missile_Control/hold4',13,'sample=.1/output'],...
    'position',[345,45,365,65])

add_block('built-in/Inport',[sys,/,['Missile_Control/hold4',13,'sample=.1/input']]
set_param([sys,/,['Missile_Control/hold4',13,'sample=.1/input'],...
    'position',[25,35,45,55])

add_block('built-in/Unit Delay',[sys,/,['Missile_Control/hold4',13,'sample=.1/Unit Delay']]
set_param([sys,/,['Missile_Control/hold4',13,'sample=.1/Unit Delay'],...
    'Sample time','Ts',...
    'position',[90,93,140,117])

add_block('built-in/Sum',[sys,/,['Missile_Control/hold4',13,'sample=.1/Sum']]
set_param([sys,/,['Missile_Control/hold4',13,'sample=.1/Sum'],...
    'inputs','+',...
    'position',[190,37,210,68])

add_block('built-in/Integrator',[sys,/,['Missile_Control/hold4',13,'sample=.1/Integrator']]
set_param([sys,/,['Missile_Control/hold4',13,'sample=.1/Integrator'],...
    'position',[235,42,260,68])

add_block('built-in/Gain',[sys,/,['Missile_Control/hold4',13,'sample=.1/Gain']]
set_param([sys,/,['Missile_Control/hold4',13,'sample=.1/Gain'],...
    'Gain','1/Ts',...
    'position',[285,33,325,77])

add_block('built-in/Zero-Order Hold',[sys,/,['Missile_Control/hold4',13,'sample=.1/Zero-Order',13,'Hold']]
set_param([sys,/,['Missile_Control/hold4',13,'sample=.1/Zero-Order',13,'Hold'],...
    'Sample time','Ts',...
    'position',[100,29,135,61])
add_line([sys,/,['Missile_Control/hold4',13,'sample=.1']], [50,45;95,45])
add_line([sys,/,['Missile_Control/hold4',13,'sample=.1']], [65,45;65,105;85,105])
add_line([sys,/,['Missile_Control/hold4',13,'sample=.1']], [140,45;185,45])
add_line([sys,/,['Missile_Control/hold4',13,'sample=.1']], [145,105;165,105;165,60;185,60])
add_line([sys,/,['Missile_Control/hold4',13,'sample=.1']], [215,55;230,55])

```



```

add_line([sys./,'Missile_Control/hold4',13,'sample=.1'],[265,55;280,55])
add_line([sys./,'Missile_Control/hold4',13,'sample=.1'],[330,55;340,55])
set_param([sys./,'Missile_Control/hold4',13,'sample=.1'],...
    'Mask Display','plot(0,0,100,100,[90,70,50,30,10],[60,40,80,30,20])',...
    'Mask Type','First-Order Hold',...
    'Mask Dialogue','First-Order Hold|Sample Time:')
set_param([sys./,'Missile_Control/hold4',13,'sample=.1'],...
    'Mask Translate','Ts=@1;',...
    'Mask Help','Implements a First-Order sample-and-hold latch operating at the sampling
interval you specify.',...
    'Mask Entries','.1V')

```

```

% Finished composite block ['Missile_Control/hold4',13,'sample=.1'].

```

```

set_param([sys./,'Missile_Control/hold4',13,'sample=.1'],...
    'position',[200,239,235,271])

```

```

add_block('built-in/MATLAB Fcn',[sys./,'Missile_Control/Relative Angle',13,'between LOS
and',13,'Bearing',13,'relanglr.m'])
set_param([sys./,'Missile_Control/Relative Angle',13,'between LOS and',13,'Bearing',13,'relanglr.m'],...
    'MATLAB Fcn','relanglr',...
    'Output Width','1',...
    'position',[225,135,275,165])

```

```

add_block('built-in/Sum',[sys./,'Missile_Control/sum5n'])
set_param([sys./,'Missile_Control/sum5n'],...
    'position',[905,138,930,162])

```

```

add_block('built-in/Integrator',[sys./,'Missile_Control/Integr',13,'ator8'])
set_param([sys./,'Missile_Control/Integr',13,'ator8'],...
    'position',[950,135,970,155])

```

```

add_block('built-in/Integrator',[sys./,'Missile_Control/Integr',13,'ator7'])
set_param([sys./,'Missile_Control/Integr',13,'ator7'],...
    'position',[990,135,1010,155])

```

```

add_block('built-in/Product',[sys./,'Missile_Control/m10'])
set_param([sys./,'Missile_Control/m10'],...
    'position',[1040,130,1065,150])

```

```

add_block('built-in/MATLAB Fcn',[sys./,'Missile_Control/testnan.m_'])
set_param([sys./,'Missile_Control/testnan.m_'],...
    'MATLAB Fcn','testnan',...
    'position',[1085,125,1135,155])

```

```

add_block('built-in/Constant',[sys./,'Missile_Control/MThrust_Duration'])
set_param([sys./,'Missile_Control/MThrust_Duration'],...
    'Value','MThrust_Duration',...
    'position',[885,296,1005,314])

```

```

add_block('built-in/Constant',[sys./,'Missile_Control/shottime'])
set_param([sys./,'Missile_Control/shottime'],...
    'Value','shottime',...
    'position',[915,267,1005,283])

```

```

add_block('built-in/Inport',[sys,/, 'Missile_Control/in_4'])
set_param([sys,/, 'Missile_Control/in_4'],...
    'Port','4',...
    'position',[1045,235,1065,255])

add_block('built-in/Mux',[sys,/, 'Missile_Control/Mux5'])
set_param([sys,/, 'Missile_Control/Mux5'],...
    'inputs','3',...
    'position',[1095,230,1130,320])

add_block('built-in/MATLAB Fcn',[sys,/, 'Missile_Control/missilego.m'])
set_param([sys,/, 'Missile_Control/missilego.m'],...
    'MATLAB Fcn','missilego',...
    'Output Width','1',...
    'position',[1185,260,1235,290])

add_block('built-in/To Workspace',[sys,/, 'Missile_Control/test'])
set_param([sys,/, 'Missile_Control/test'],...
    'mat-name','missilevel',...
    'buffer','1000000000',...
    'position',[1295,307,1375,323])

add_block('built-in/Product',[sys,/, 'Missile_Control/m17'])
set_param([sys,/, 'Missile_Control/m17'],...
    'position',[1320,195,1345,215])

add_block('built-in/Integrator',[sys,/, 'Missile_Control/Integrator3'])
set_param([sys,/, 'Missile_Control/Integrator3'],...
    'position',[1385,195,1405,215])

add_block('built-in/Integrator',[sys,/, 'Missile_Control/Integrator2'])
set_param([sys,/, 'Missile_Control/Integrator2'],...
    'position',[1385,135,1405,155])

add_block('built-in/Product',[sys,/, 'Missile_Control/m18'])
set_param([sys,/, 'Missile_Control/m18'],...
    'position',[1320,135,1345,155])

add_block('built-in/Fcn',[sys,/, 'Missile_Control/Fcn2'])
set_param([sys,/, 'Missile_Control/Fcn2'],...
    'position',[1200,130,1285,150])

add_block('built-in/Fcn',[sys,/, 'Missile_Control/Fcn3'])
set_param([sys,/, 'Missile_Control/Fcn3'],...
    'Expr','cos(u[1]),...
    'position',[1205,198,1290,222])

add_block('built-in/Outport',[sys,/, 'Missile_Control/sin pos'])
set_param([sys,/, 'Missile_Control/sin pos'],...
    'position',[1465,140,1485,160])

add_block('built-in/Outport',[sys,/, 'Missile_Control/out_2'])
set_param([sys,/, 'Missile_Control/out_2'],...
    'Port','2',...

```

```

        'position',[1465,190,1485,210])

add_block('built-in/Product',[sys,/, 'Missile_Control/mn5'])
set_param([sys,/, 'Missile_Control/mn5'],...
    'inputs',3,...
    'position',[825,207,850,263])

add_block('built-in/Constant',[sys,/, ['Missile_Control/MThrustN Standard ',13,'Deviation']])
set_param([sys,/, ['Missile_Control/MThrustN Standard ',13,'Deviation']],...
    'Value','MThrustNstd',...
    'position',[620,247,710,263])

add_block('built-in/White Noise',[sys,/, 'Missile_Control/White Noise 5'])
set_param([sys,/, 'Missile_Control/White Noise 5'],...
    'Seed','noiseseed(5)',...
    'position',[745,220,765,240])

add_block('built-in/Transfer Fcn',[sys,/, ['Missile_Control/Transfer ',13,'Fcn11']])
set_param([sys,/, ['Missile_Control/Transfer ',13,'Fcn11']],...
    'Denominator',[.00694444 .05 1],...
    'position',[655,123,800,167])

add_block('built-in/Transfer Fcn',[sys,/, ['Missile_Control/Transfer ',13,'Fcn10']])
set_param([sys,/, ['Missile_Control/Transfer ',13,'Fcn10']],...
    'Numerator',[2 1],...
    'Denominator',[1 0],...
    'position',[595,127,635,163])

add_block('built-in/Constant',[sys,/, 'Missile_Control/Acquire Std Dev'])
set_param([sys,/, 'Missile_Control/Acquire Std Dev'],...
    'Value','AcquireNstd',...
    'position',[140,323,230,347])

add_block('built-in/Note',[sys,/, 'Missile_Control/BLOCK: Missile_Control'])
set_param([sys,/, 'Missile_Control/BLOCK: Missile_Control'],...
    'position',[635,405,640,410])
add_line([sys,/, 'Missile_Control'],[1240,275;1297,275;1297,200;1315,200])
add_line([sys,/, 'Missile_Control'],[1297,200;1297,150;1315,150])
add_line([sys,/, 'Missile_Control'],[1135,275;1180,275])
add_line([sys,/, 'Missile_Control'],[1010,305;1090,305])
add_line([sys,/, 'Missile_Control'],[1010,275;1090,275])
add_line([sys,/, 'Missile_Control'],[1240,275;1257,275;1257,315;1290,315])
add_line([sys,/, 'Missile_Control'],[300,260;320,260;330,170])
add_line([sys,/, 'Missile_Control'],[240,255;265,255])
add_line([sys,/, 'Missile_Control'],[175,255;195,255])
add_line([sys,/, 'Missile_Control'],[235,335;253,335;253,265;265,265])
add_line([sys,/, 'Missile_Control'],[805,145;900,145])
add_line([sys,/, 'Missile_Control'],[770,230;787,230;787,235;820,235])
add_line([sys,/, 'Missile_Control'],[715,255;820,255])
add_line([sys,/, 'Missile_Control'],[330,60;370,60;380,140])
add_line([sys,/, 'Missile_Control'],[370,127;370,90;410,90])
add_line([sys,/, 'Missile_Control'],[470,90;515,90])
add_line([sys,/, 'Missile_Control'],[935,150;945,145])
add_line([sys,/, 'Missile_Control'],[280,150;330,150])
add_line([sys,/, 'Missile_Control'],[645,90;1017,90;1017,135;1035,135])

```

```

add_line([sys,'','Missile_Control'],[565,90;585,90])
add_line([sys,'','Missile_Control'],[1140,140;1195,140])
add_line([sys,'','Missile_Control'],[1070,140;1080,140])
add_line([sys,'','Missile_Control'],[1350,205;1380,205])
add_line([sys,'','Missile_Control'],[1295,210;1315,210])
add_line([sys,'','Missile_Control'],[1290,140;1315,140])
add_line([sys,'','Missile_Control'],[1350,145;1380,145])
add_line([sys,'','Missile_Control'],[450,145;455,145])
add_line([sys,'','Missile_Control'],[415,145;420,145])
add_line([sys,'','Missile_Control'],[585,145;590,145])
add_line([sys,'','Missile_Control'],[640,145;650,145])
add_line([sys,'','Missile_Control'],[1015,145;1035,145])
add_line([sys,'','Missile_Control'],[975,145;985,145])
add_line([sys,'','Missile_Control'],[360,160;380,150])
add_line([sys,'','Missile_Control'],[190,150;220,150])
add_line([sys,'','Missile_Control'],[85,130;150,130])
add_line([sys,'','Missile_Control'],[1410,145;1422,145;1460,150])
add_line([sys,'','Missile_Control'],[130,165;150,165])
add_line([sys,'','Missile_Control'],[1410,205;1422,205;1460,200])
add_line([sys,'','Missile_Control'],[1070,245;1090,245])
add_line([sys,'','Missile_Control'],[1140,140;1165,140;1165,200;310,200;310,160;330,160])
add_line([sys,'','Missile_Control'],[855,235;865,235;865,155;900,155])
add_line([sys,'','Missile_Control'],[805,145;810,145;820,215])
add_line([sys,'','Missile_Control'],[1165,200;1165,210;1200,210])
set_param([sys,'','Missile_Control'],...
    'Mask Display','AC position (x,y,z)      \nMissile range      sin pos\nMissile (x,y,z)
\nTime      cos pos')

```

% Finished composite block 'Missile_Control'.

```

set_param([sys,'','Missile_Control'],...
    'position',[375,288,525,347])

add_block('built-in/To Workspace',[sys,'','time'])
set_param([sys,'','time'],...
    'mat-name','time',...
    'buffer','1000000',...
    'position',[150,507,200,523])

add_block('built-in/Clock',[sys,'','Clock'])
set_param([sys,'','Clock'],...
    'position',[55,505,75,525])

```

% Subsystem 'A/C'.

```

new_system([sys,'','A/C'])
set_param([sys,'','A/C'],'Location',[77,99,1109,692])

add_block('built-in/To Workspace',[sys,'','A/C/zac1'])
set_param([sys,'','A/C/zac1'],...
    'mat-name','zac',...
    'buffer','1000000000',...
    'position',[730,132,780,148])

```

```

add_block('built-in/To Workspace',[sys,'/','A//C/yac1'])
set_param([sys,'/','A//C/yac1'],...
    'mat-name','yac',...
    'buffer','1000000000',...
    'position',[865,407,915,423])

add_block('built-in/Mux',[sys,'/','A//C/ac pos'])
set_param([sys,'/','A//C/ac pos'],...
    'orientation',1,...
    'inputs','3',...
    'position',[914,365,966,405])

add_block('built-in/To Workspace',[sys,'/','A//C/xac1'])
set_param([sys,'/','A//C/xac1'],...
    'mat-name','xac',...
    'buffer','1000000000',...
    'position',[890,217,940,233])

add_block('built-in/Sum',[sys,'/','A//C/Sum13'])
set_param([sys,'/','A//C/Sum13'],...
    'inputs','+',...
    'position',[820,259,840,281])

add_block('built-in/Sum',[sys,'/','A//C/Sumn3c'])
set_param([sys,'/','A//C/Sumn3c'],...
    'position',[745,338,770,362])

add_block('built-in/Gain',[sys,'/','A//C/Gain2'])
set_param([sys,'/','A//C/Gain2'],...
    'Gain','-1',...
    'position',[810,340,830,360])

add_block('built-in/Product',[sys,'/','A//C/m22'])
set_param([sys,'/','A//C/m22'],...
    'position',[600,480,625,500])

add_block('built-in/Constant',[sys,'/','A//C/AC crosswind'])
set_param([sys,'/','A//C/AC crosswind'],...
    'Value','accrosswind',...
    'position',[460,455,555,475])

add_block('built-in/White Noise',[sys,'/','A//C/White Noise',13,'3'])
set_param([sys,'/','A//C/White Noise',13,'3'],...
    'Seed','noiseseed(3)',...
    'position',[435,395,455,415])

% Subsystem ['A//C/hold3',13,'sample=1'].

new_system([sys,'/','A//C/hold3',13,'sample=1'])
set_param([sys,'/','A//C/hold3',13,'sample=1'],'Location',[511,151,915,322])

add_block('built-in/Zero-Order Hold',[sys,'/','A//C/hold3',13,'sample=1/Zero-Order',13,'Hold'])
set_param([sys,'/','A//C/hold3',13,'sample=1/Zero-Order',13,'Hold'],...

```

```

'Sample time','Ts',...
'position',[100,29,135,61])

add_block('built-in/Gain',[sys,/,['A//C/hold3',13,'sample=1/Gain']])
set_param([sys,/,['A//C/hold3',13,'sample=1/Gain']],...
'Gain','1/Ts',...
'position',[285,33,325,77])

add_block('built-in/Integrator',[sys,/,['A//C/hold3',13,'sample=1/Integrator']])
set_param([sys,/,['A//C/hold3',13,'sample=1/Integrator']],...
'position',[235,42,260,68])

add_block('built-in/Sum',[sys,/,['A//C/hold3',13,'sample=1/Sum']])
set_param([sys,/,['A//C/hold3',13,'sample=1/Sum']],...
'inputs','+',...
'position',[190,37,210,68])

add_block('built-in/Unit Delay',[sys,/,['A//C/hold3',13,'sample=1/Unit Delay']])
set_param([sys,/,['A//C/hold3',13,'sample=1/Unit Delay']],...
'Sample time','Ts',...
'position',[90,93,140,117])

add_block('built-in/Inport',[sys,/,['A//C/hold3',13,'sample=1/input']])
set_param([sys,/,['A//C/hold3',13,'sample=1/input']],...
'position',[25,35,45,55])

add_block('built-in/Outport',[sys,/,['A//C/hold3',13,'sample=1/output']])
set_param([sys,/,['A//C/hold3',13,'sample=1/output']],...
'position',[345,45,365,65])
add_line([sys,/,['A//C/hold3',13,'sample=1']], [330,55;340,55])
add_line([sys,/,['A//C/hold3',13,'sample=1']], [265,55;280,55])
add_line([sys,/,['A//C/hold3',13,'sample=1']], [215,55;230,55])
add_line([sys,/,['A//C/hold3',13,'sample=1']], [145,105;165,105;165,60;185,60])
add_line([sys,/,['A//C/hold3',13,'sample=1']], [140,45;185,45])
add_line([sys,/,['A//C/hold3',13,'sample=1']], [50,45;95,45])
add_line([sys,/,['A//C/hold3',13,'sample=1']], [65,45;65,105;85,105])
set_param([sys,/,['A//C/hold3',13,'sample=1']],...
'Mask Display','plot(0,0,100,100,[90,70,50,30,10],[60,40,80,30,20])',...
'Mask Type','First-Order Hold',...
'Mask Dialogue','First-Order Hold|Sample Time:',...
'Mask Translate','Ts=@ 1:')
set_param([sys,/,['A//C/hold3',13,'sample=1']],...
'Mask Help','Implements a First-Order sample-and-hold latch operating at the sampling
interval you specify.',...
'Mask Entries','IV')

% Finished composite block ['A//C/hold3',13,'sample=1'].

set_param([sys,/,['A//C/hold3',13,'sample=1']],...
'position',[490,389,525,421])

add_block('built-in/Product',[sys,/,['A//C/Productn3']])
set_param([sys,/,['A//C/Productn3']],...
'position',[560,390,585,410])

```

```

add_block('built-in/Sum',[sys,'/','A//C/Sumn3a'])
set_param([sys,'/','A//C/Sumn3a'],...
           'position',[655,383,680,407])

add_block('built-in/Mux',[sys,'/','A//C/Mux16'])
set_param([sys,'/','A//C/Mux16'],...
           'inputs','2',...
           'position',[625,181,655,214])

add_block('built-in/Fcn',[sys,'/','A//C/Fcn'])
set_param([sys,'/','A//C/Fcn'],...
           'position',[370,148,445,172])

add_block('built-in/Fcn',[sys,'/','A//C/Fcn6'])
set_param([sys,'/','A//C/Fcn6'],...
           'Expr','cos(u[1])',...
           'position',[490,274,570,296])

add_block('built-in/Fcn',[sys,'/','A//C/Fcn4'])
set_param([sys,'/','A//C/Fcn4'],...
           'position',[490,339,570,361])

add_block('built-in/Product',[sys,'/','A//C/Product'])
set_param([sys,'/','A//C/Product'],...
           'position',[485,155,510,175])

add_block('built-in/Integrator',[sys,'/','A//C/Int1'])
set_param([sys,'/','A//C/Int1'],...
           'position',[550,155,570,175])

add_block('built-in/Integrator',[sys,'/','A//C/Int'])
set_param([sys,'/','A//C/Int'],...
           'position',[550,215,570,235])

add_block('built-in/Fcn',[sys,'/','A//C/Fcn1'])
set_param([sys,'/','A//C/Fcn1'],...
           'Expr','cos(u[1])',...
           'position',[365,219,445,241])

add_block('built-in/Product',[sys,'/','A//C/Product1'])
set_param([sys,'/','A//C/Product1'],...
           'position',[485,215,510,235])

add_block('built-in/Product',[sys,'/','A//C/m5'])
set_param([sys,'/','A//C/m5'],...
           'position',[605,300,630,320])

add_block('built-in/Product',[sys,'/','A//C/m4'])
set_param([sys,'/','A//C/m4'],...
           'position',[600,265,625,285])

add_block('built-in/Note',[sys,'/','A//C/c'])
set_param([sys,'/','A//C/c'],...
           'position',[645,260,650,265])

```

```

add_block('built-in/Note',[sys,'/','A//C/d'])
set_param([sys,'/','A//C/d'],...
           'position',[645,310,650,315])

add_block('built-in/White Noise',[sys,'/','A//C/White Noise',13,'1'])
set_param([sys,'/','A//C/White Noise',13,'1'],...
           'Seed','noiseseed(1)',...
           'position',[85,45,105,65])

add_block('built-in/Product',[sys,'/','A//C/mn1'])
set_param([sys,'/','A//C/mn1'],...
           'position',[225,95,250,115])

add_block('built-in/Sum',[sys,'/','A//C/sumn1b'])
set_param([sys,'/','A//C/sumn1b'],...
           'position',[290,100,310,120])

add_block('built-in/Constant',[sys,'/','A//C/a/c climb',13,'velocity',13,''])
set_param([sys,'/','A//C/a/c climb',13,'velocity',13,''],...
           'Value','acvel',...
           'position',[170,147,210,163])

add_block('built-in/Constant',[sys,'/','A//C/AC Velocity',13,'Noise std dev'])
set_param([sys,'/','A//C/AC Velocity',13,'Noise std dev'],...
           'Value','acvelstd',...
           'position',[85,100,145,120])

% Subsystem ['A//C/hold1',13,'sample=.25'].

new_system([sys,'/','A//C/hold1',13,'sample=.25'])
set_param([sys,'/','A//C/hold1',13,'sample=.25'],'Location',[511,151,915,322])

add_block('built-in/Zero-Order Hold',[sys,'/','A//C/hold1',13,'sample=.25/Zero-Order',13,'Hold'])
set_param([sys,'/','A//C/hold1',13,'sample=.25/Zero-Order',13,'Hold'],...
           'Sample time','Ts',...
           'position',[100,29,135,61])

add_block('built-in/Gain',[sys,'/','A//C/hold1',13,'sample=.25/Gain'])
set_param([sys,'/','A//C/hold1',13,'sample=.25/Gain'],...
           'Gain','1/Ts',...
           'position',[285,33,325,77])

add_block('built-in/Integrator',[sys,'/','A//C/hold1',13,'sample=.25/Integrator'])
set_param([sys,'/','A//C/hold1',13,'sample=.25/Integrator'],...
           'position',[235,42,260,68])

add_block('built-in/Sum',[sys,'/','A//C/hold1',13,'sample=.25/Sum'])
set_param([sys,'/','A//C/hold1',13,'sample=.25/Sum'],...
           'inputs','+',...
           'position',[190,37,210,68])

add_block('built-in/Unit Delay',[sys,'/','A//C/hold1',13,'sample=.25/Unit Delay'])
set_param([sys,'/','A//C/hold1',13,'sample=.25/Unit Delay'],...

```



```

'Sample time','Ts'....
'position',[90,93,140,117])

add_block('built-in/Inport',[sys,'/','A//C/hold1',13,'sample=.25/input'])
set_param([sys,'/','A//C/hold1',13,'sample=.25/input'],...
'position',[25,35,45,55])

add_block('built-in/Outport',[sys,'/','A//C/hold1',13,'sample=.25/output'])
set_param([sys,'/','A//C/hold1',13,'sample=.25/output'],...
'position',[345,45,365,65])
add_line([sys,'/','A//C/hold1',13,'sample=.25'],[330,55;340,55])
add_line([sys,'/','A//C/hold1',13,'sample=.25'],[265,55;280,55])
add_line([sys,'/','A//C/hold1',13,'sample=.25'],[215,55;230,55])
add_line([sys,'/','A//C/hold1',13,'sample=.25'],[145,105;165,105;165,60;185,60])
add_line([sys,'/','A//C/hold1',13,'sample=.25'],[140,45;185,45])
add_line([sys,'/','A//C/hold1',13,'sample=.25'],[50,45;95,45])
add_line([sys,'/','A//C/hold1',13,'sample=.25'],[65,45;65,105;85,105])
set_param([sys,'/','A//C/hold1',13,'sample=.25'],...
'Mask Display','plot(0,0,100,100,[90,70,50,30,10],[60,40,80,30,20])',...
'Mask Type','First-Order Hold',...
'Mask Dialogue','First-Order Hold(Sample Time:)'
set_param([sys,'/','A//C/hold1',13,'sample=.25'],...
'Mask Translate','Ts=@ 1;',...
'Mask Help','Implements a First-Order sample-and-hold latch operating at the sampling
interval you specify.',...
'Mask Entries','.25V')

% Finished composite block ['A//C/hold1',13,'sample=.25'].

set_param([sys,'/','A//C/hold1',13,'sample=.25'],...
'position',[145,39,180,71])

add_block('built-in/Outport',[sys,'/','A//C/AC velocity (z,x)'])
set_param([sys,'/','A//C/AC velocity (z,x)'],...
'position',[1020,190,1040,210])

add_block('built-in/Outport',[sys,'/','A//C/AC position (x,y,z)'])
set_param([sys,'/','A//C/AC position (x,y,z)'],...
'orientation',1,...
'Port','2',...
'position',[1005,430,1025,450])

add_block('built-in/Constant',[sys,'/','A//C/a/c climb',13,'angle1'])
set_param([sys,'/','A//C/a/c climb',13,'angle1'],...
'Value','acclimbangle',...
'position',[120,342,205,358])

add_block('built-in/Sum',[sys,'/','A//C/Sumn2b'])
set_param([sys,'/','A//C/Sumn2b'],...
'position',[235,295,255,315])

add_block('built-in/Constant',[sys,'/','A//C/Ac Angle',13,'std dev'])
set_param([sys,'/','A//C/Ac Angle',13,'std dev'],...
'Value','acangstd',...

```

```

        'position',[70,305,125,325])

add_block('built-in/Product',[sys,/, 'A/C/mn2'])
set_param([sys,/, 'A/C/mn2'],...
    'position',[180,290,205,310])

% Subsystem ['A/C/hold2',13,'sample=1'].

new_system([sys,/, ['A/C/hold2',13,'sample=1']])
set_param([sys,/, ['A/C/hold2',13,'sample=1']], 'Location',[511,151,915,322])

add_block('built-in/Zero-Order Hold',[sys,/, ['A/C/hold2',13,'sample=1/Zero-Order',13,'Hold']])
set_param([sys,/, ['A/C/hold2',13,'sample=1/Zero-Order',13,'Hold']],...
    'Sample time','Ts',...
    'position',[100,29,135,61])

add_block('built-in/Gain',[sys,/, ['A/C/hold2',13,'sample=1/Gain']])
set_param([sys,/, ['A/C/hold2',13,'sample=1/Gain']],...
    'Gain','1/Ts',...
    'position',[285,33,325,77])

add_block('built-in/Integrator',[sys,/, ['A/C/hold2',13,'sample=1/Integrator']])
set_param([sys,/, ['A/C/hold2',13,'sample=1/Integrator']],...
    'position',[235,42,260,68])

add_block('built-in/Sum',[sys,/, ['A/C/hold2',13,'sample=1/Sum']])
set_param([sys,/, ['A/C/hold2',13,'sample=1/Sum']],...
    'inputs','+' ,...
    'position',[190,37,210,68])

add_block('built-in/Unit Delay',[sys,/, ['A/C/hold2',13,'sample=1/Unit Delay']])
set_param([sys,/, ['A/C/hold2',13,'sample=1/Unit Delay']],...
    'Sample time','Ts',...
    'position',[90,93,140,117])

add_block('built-in/Inport',[sys,/, ['A/C/hold2',13,'sample=1/input']])
set_param([sys,/, ['A/C/hold2',13,'sample=1/input']],...
    'position',[25,35,45,55])

add_block('built-in/Outport',[sys,/, ['A/C/hold2',13,'sample=1/output']])
set_param([sys,/, ['A/C/hold2',13,'sample=1/output']],...
    'position',[345,45,365,65])
add_line([sys,/, ['A/C/hold2',13,'sample=1']], [330,55;340,55])
add_line([sys,/, ['A/C/hold2',13,'sample=1']], [265,55;280,55])
add_line([sys,/, ['A/C/hold2',13,'sample=1']], [215,55;230,55])
add_line([sys,/, ['A/C/hold2',13,'sample=1']], [145,105;165,105;165,60;185,60])
add_line([sys,/, ['A/C/hold2',13,'sample=1']], [140,45;185,45])
add_line([sys,/, ['A/C/hold2',13,'sample=1']], [50,45;95,45])
add_line([sys,/, ['A/C/hold2',13,'sample=1']], [65,45;65,105;85,105])
set_param([sys,/, ['A/C/hold2',13,'sample=1']],...
    'Mask Display','plot(0,0,100,100,[90,70,50,30,10],[60,40,80,30,20])',...
    'Mask Type','First-Order Hold',...
    'Mask Dialogue','First-Order Hold|Sample Time:',...
    'Mask Translate','Ts=@1;')

```

```

set_param([sys,'/','A//C/hold2',13,'sample=1'],...
'Mask Help','Implements a First-Order sample-and-hold latch operating at the sampling
interval you specify.'....
'Mask Entries','1V')

```

```

% Finished composite block ['A//C/hold2',13,'sample=1'].

```

```

set_param([sys,'/','A//C/hold2',13,'sample=1'],...
'position',[120,239,155,271])

```

```

add_block('built-in/White Noise',[sys,'/','A//C/White Noise',13,' 2'])
set_param([sys,'/','A//C/White Noise',13,' 2'],...
'Seed','noiseseed(2)',...
'position',[70,245.90,265])

```

```

add_block('built-in/Constant',[sys,'/','A//C/Missile range ',13,'from A//C rotation'])
set_param([sys,'/','A//C/Missile range ',13,'from A//C rotation'],...
'Value','missilerange',...
'position',[340,296,420,314])

```

```

add_block('built-in/Constant',[sys,'/','A//C/Initial missile angle',13,'in XY plane'])
set_param([sys,'/','A//C/Initial missile angle',13,'in XY plane'],...
'Value','missiletheta',...
'position',[335,341,425,359])

```

```

add_block('built-in/Inport',[sys,'/','A//C/Time'])
set_param([sys,'/','A//C/Time'],...
'position',[345,485,365,505])

```

```

add_block('built-in/Constant',[sys,'/','A//C/ACypos ',13,'std dev.'])
set_param([sys,'/','A//C/ACypos ',13,'std dev.'],...
'Value','acystd',...
'position',[365,440,420,460])

```

```

add_block('built-in/Note',[sys,'/','A//C/BLOCK: A//C'])
set_param([sys,'/','A//C/BLOCK: A//C'],...
'position',[500,550,505,555])

```

```

add_line([sys,'/','A//C'],[575,165;955,165;955,360])
add_line([sys,'/','A//C'],[685,165;685,140;725,140])
add_line([sys,'/','A//C'],[835,350;940,360])
add_line([sys,'/','A//C'],[845,350;845,415;860,415])
add_line([sys,'/','A//C'],[845,270;925,270;925,360])
add_line([sys,'/','A//C'],[875,270;885,225])
add_line([sys,'/','A//C'],[590,400;615,400;615,390;650,390])
add_line([sys,'/','A//C'],[630,490;635,490;635,400;650,400])
add_line([sys,'/','A//C'],[560,465;570,465;570,485;595,485])
add_line([sys,'/','A//C'],[460,405;485,405])
add_line([sys,'/','A//C'],[530,405;535,405;535,395;555,395])
add_line([sys,'/','A//C'],[685,395;720,395;720,355;740,355])
add_line([sys,'/','A//C'],[130,315;145,315;145,305;175,305])
add_line([sys,'/','A//C'],[160,255;165,255;175,295])
add_line([sys,'/','A//C'],[95,255;115,255])
add_line([sys,'/','A//C'],[210,300;230,300])
add_line([sys,'/','A//C'],[150,110;220,110])

```

```

add_line([sys,'/','A/C'],[255,105;285,105])
add_line([sys,'/','A/C'],[185,55;205,55;205,100;220,100])
add_line([sys,'/','A/C'],[110,55;140,55])
add_line([sys,'/','A/C'],[515,225;545,225])
add_line([sys,'/','A/C'],[525,225;525,205;620,205])
add_line([sys,'/','A/C'],[515,165;545,165])
add_line([sys,'/','A/C'],[525,165;525,190;620,190])
add_line([sys,'/','A/C'],[775,350;805,350])
add_line([sys,'/','A/C'],[635,310;680,310;680,345;740,345])
add_line([sys,'/','A/C'],[425,450;541,450;541,405;555,405])
add_line([sys,'/','A/C'],[260,305;315,305;315,160;365,160])
add_line([sys,'/','A/C'],[315,230;360,230])
add_line([sys,'/','A/C'],[210,350;215,350;215,310;230,310])
add_line([sys,'/','A/C'],[315,110;455,110;455,190;465,190;465,220;480,220])
add_line([sys,'/','A/C'],[465,190;465,170;480,170])
add_line([sys,'/','A/C'],[215,155;272,155;272,115;285,115])
add_line([sys,'/','A/C'],[575,285;580,280;595,280])
add_line([sys,'/','A/C'],[575,350;585,350;585,315;600,315])
add_line([sys,'/','A/C'],[425,305;600,305])
add_line([sys,'/','A/C'],[425,305;455,305;455,270;595,270])
add_line([sys,'/','A/C'],[430,350;485,350])
add_line([sys,'/','A/C'],[430,350;470,350;470,285;485,285])
add_line([sys,'/','A/C'],[630,275;815,275])
add_line([sys,'/','A/C'],[450,230;480,230])
add_line([sys,'/','A/C'],[450,160;480,160])
add_line([sys,'/','A/C'],[575,225;590,225;590,265;815,265])
add_line([sys,'/','A/C'],[660,200;1015,200])
add_line([sys,'/','A/C'],[940,410;940,415;1015,425])
add_line([sys,'/','A/C'],[370,495;595,495])
set_param([sys,'/','A/C'],...
    'Mask Display', AC velocity (z,x)\nTime          \n AC position (x,y,z))

```

% Finished composite block 'A/C'.

```

set_param([sys,'/','A/C'],...
    'position',[145,259,275,306])

add_block('built-in/MATLAB Fcn',[sys,'/','expos1.m'])
set_param([sys,'/','expos1.m'],...
    'orientation',2,...
    'MATLAB Fcn','expos1',...
    'Output Width','9',...
    'position',[1530,15,1580,45])

add_block('built-in/To Workspace',[sys,'/','xexp1'])
set_param([sys,'/','xexp1'],...
    'mat-name','xexp1',...
    'buffer','1000000000',...
    'position',[1750,70,1800,90])

add_block('built-in/To Workspace',[sys,'/','yexp1'])
set_param([sys,'/','yexp1'],...
    'mat-name','yexp1',...
    'buffer','1000000000',...

```

```

        'position',[1695,90,1745,110])

add_block('built-in/To Workspace',[sys,/, 'zexp1'])
set_param([sys,/, 'zexp1'],...
    'mat-name','zexp1',...
    'buffer','1000000000',...
    'position',[1755,120,1805,140])

add_block('built-in/To Workspace',[sys,/, 'PK1'])
set_param([sys,/, 'PK1'],...
    'mat-name','PK1',...
    'buffer','1000000000',...
    'position',[1695,150,1745,170])

add_block('built-in/Stop Simulation',[sys,/, ['Stop simulation ',13,'if non-zero1']])
set_param([sys,/, ['Stop simulation ',13,'if non-zero1']],...
    'position',[1780,169,1830,211])

add_block('built-in/To Workspace',[sys,/, 'mexslanrange1'])
set_param([sys,/, 'mexslanrange1'],...
    'mat-name','mexslanrange1',...
    'buffer','1000000000',...
    'position',[1650,200,1740,220])

add_block('built-in/MATLAB Fcn',[sys,/, 'expos2.m'])
set_param([sys,/, 'expos2.m'],...
    'orientation',2,...
    'MATLAB Fcn','expos2',...
    'Output Width','9',...
    'position',[1535,270,1585,300])

add_block('built-in/To Workspace',[sys,/, 'xexp2'])
set_param([sys,/, 'xexp2'],...
    'mat-name','xexp2',...
    'buffer','1000000000',...
    'position',[1745,330,1795,350])

add_block('built-in/To Workspace',[sys,/, 'yexp2'])
set_param([sys,/, 'yexp2'],...
    'mat-name','yexp2',...
    'buffer','1000000000',...
    'position',[1695,355,1745,375])

add_block('built-in/To Workspace',[sys,/, 'zexp2'])
set_param([sys,/, 'zexp2'],...
    'mat-name','zexp2',...
    'buffer','1000000000',...
    'position',[1780,370,1830,390])

add_block('built-in/To Workspace',[sys,/, 'PK2'])
set_param([sys,/, 'PK2'],...
    'mat-name','PK2',...
    'buffer','1000000000',...
    'position',[1780,410,1830,430])

```

```
add_block('built-in/Stop Simulation',[sys,/,['Stop simulation',13,'if non-zero',13,'_2']])
set_param([sys,/,['Stop simulation',13,'if non-zero',13,'_2']],...
    'position',[1840,424,1890,466])
```

```
add_block('built-in/To Workspace',[sys,/,mexslanrange2'])
set_param([sys,/,mexslanrange2'],...
    'mat-name',mexslanrange2',...
    'buffer','1000000000',...
    'position',[1710,455,1800,475])
```

```
add_block('built-in/MATLAB Fcn',[sys,/,expos3.m'])
set_param([sys,/,expos3.m'],...
    'orientation',2,...
    'MATLAB Fcn',expos3',...
    'Output Width',9',...
    'position',[1605,530,1655,560])
```

```
add_block('built-in/To Workspace',[sys,/,xexp3'])
set_param([sys,/,xexp3'],...
    'mat-name',xexp3',...
    'buffer','1000000000',...
    'position',[1820,575,1870,595])
```

```
add_block('built-in/To Workspace',[sys,/,yexp3'])
set_param([sys,/,yexp3'],...
    'mat-name',yexp3',...
    'buffer','1000000000',...
    'position',[1760,595,1810,615])
```

```
add_block('built-in/To Workspace',[sys,/,zexp3'])
set_param([sys,/,zexp3'],...
    'mat-name',zexp3',...
    'buffer','1000000000',...
    'position',[1835,625,1885,645])
```

```
add_block('built-in/To Workspace',[sys,/,PK3'])
set_param([sys,/,PK3'],...
    'mat-name',PK3',...
    'buffer','1000000000',...
    'position',[1785,660,1835,680])
```

```
add_block('built-in/Stop Simulation',[sys,/,['Stop simulation ',13,'if non-zero_3']])
set_param([sys,/,['Stop simulation ',13,'if non-zero_3']],...
    'position',[1870,679,1920,721])
```

```
add_block('built-in/To Workspace',[sys,/,mexslanrange3'])
set_param([sys,/,mexslanrange3'],...
    'mat-name',mexslanrange3',...
    'buffer','1000000000',...
    'position',[1735,710,1825,730])
```

```
% Subsystem 'Quad_data'.
```

```
new_system([sys,/,Quad_data'])
```

```

set_param([sys, '/', 'Quad_data'], 'Location', [65, 615, 1105, 915])

add_block('built-in/Constant', [sys, '/', 'Quad_data/.95'])
set_param([sys, '/', 'Quad_data/.95'], ...
    'orientation', 2, ...
    'Value', '.95', ...
    'position', [160, 91, 185, 109])

add_block('built-in/Product', [sys, '/', 'Quad_data/mn7'])
set_param([sys, '/', 'Quad_data/mn7'], ...
    'orientation', 2, ...
    'position', [75, 107, 100, 143])

add_block('built-in/MATLAB Fcn', [sys, '/', 'Quad_data/divplus.m'])
set_param([sys, '/', 'Quad_data/divplus.m'], ...
    'orientation', 2, ...
    'MATLAB Fcn', 'divplus', ...
    'Output Width', '1', ...
    'position', [115, 118, 170, 152])

add_block('built-in/Constant', [sys, '/', 'Quad_data/Avg det. dist.'])
set_param([sys, '/', 'Quad_data/Avg det. dist.'], ...
    'orientation', 2, ...
    'Value', 'Average_detect_dist', ...
    'position', [235, 61, 370, 79])

add_block('built-in/Mux', [sys, '/', 'Quad_data/Mux21'])
set_param([sys, '/', 'Quad_data/Mux21'], ...
    'orientation', 2, ...
    'inputs', '2', ...
    'position', [185, 118, 215, 147])

add_block('built-in/Sum', [sys, '/', 'Quad_data/sum5n2'])
set_param([sys, '/', 'Quad_data/sum5n2'], ...
    'orientation', 2, ...
    'inputs', '+', ...
    'position', [275, 93, 300, 117])

add_block('built-in/Product', [sys, '/', 'Quad_data/mn6'])
set_param([sys, '/', 'Quad_data/mn6'], ...
    'orientation', 2, ...
    'inputs', '3', ...
    'position', [330, 102, 355, 138])

add_block('built-in/Outport', [sys, '/', 'Quad_data/out_1'])
set_param([sys, '/', 'Quad_data/out_1'], ...
    'orientation', 2, ...
    'position', [25, 115, 45, 135])

add_block('built-in/Fcn', [sys, '/', 'Quad_data/Fcn7'])
set_param([sys, '/', 'Quad_data/Fcn7'], ...
    'orientation', 2, ...
    'Expr', 'cos(u[1])', ...
    'position', [505, 99, 575, 121])

```

```

add_block('built-in/Constant',[sys,/, 'Quad_data/deltaphi'])
set_param([sys,/, 'Quad_data/deltaphi'],...
    'orientation',2,...
    'Value','((90/57.3)+acclimbangle-(93.12/57.3))',...
    'position',[605,101,880,119])

add_block('built-in/Constant',[sys,/, 'Quad_data/AC velocity'])
set_param([sys,/, 'Quad_data/AC velocity'],...
    'orientation',2,...
    'Value','acvel',...
    'position',[420,122,470,138])

add_block('built-in/Constant',[sys,/, 'Quad_data/pi'])
set_param([sys,/, 'Quad_data/pi'],...
    'orientation',2,...
    'Value','pi',...
    'position',[730,161,755,179])

add_block('built-in/Sum',[sys,/, 'Quad_data/sum5n1'])
set_param([sys,/, 'Quad_data/sum5n1'],...
    'orientation',2,...
    'inputs','+',...
    'position',[680,153,705,177])

add_block('built-in/Demux',[sys,/, 'Quad_data/Demux2'])
set_param([sys,/, 'Quad_data/Demux2'],...
    'orientation',2,...
    'outputs','2',...
    'position',[780,141,820,174])

add_block('built-in/Switch',[sys,/, ['Quad_data/Switch ',13,'threshold=pi//2']])
set_param([sys,/, ['Quad_data/Switch ',13,'threshold=pi//2']],...
    'orientation',2,...
    'Threshold','90/57.3',...
    'position',[840,144,870,176])

add_block('built-in/Output',[sys,/, 'Quad_data/quad_time_to_target'])
set_param([sys,/, 'Quad_data/quad_time_to_target'],...
    'orientation',2,...
    'Port','2',...
    'position',[740,200,760,220])

add_block('built-in/Fcn',[sys,/, 'Quad_data/Fcn5'])
set_param([sys,/, 'Quad_data/Fcn5'],...
    'orientation',2,...
    'Expr','cos(u[1])',...
    'position',[555,155,625,175])

add_block('built-in/Constant',[sys,/, 'Quad_data/front shot info'])
set_param([sys,/, 'Quad_data/front shot info'],...
    'orientation',2,...
    'Value','front_shot_info',...
    'position',[950,187,1035,203])

add_block('built-in/Inport',[sys,/, 'Quad_data/acmtheta'])

```



```

set_param([sys,'/','Quad_data/acmtheta'],...
          'orientation',2,...
          'position',[1000,153,1020,167])

add_block('built-in/Constant',[sys,'/','Quad_data/rear shot info1'])
set_param([sys,'/','Quad_data/rear shot info1'],...
          'orientation',2,...
          'Value','rear_shot_info'....
          'position',[1035,142,1120,158])

add_block('built-in/Constant',[sys,'/','Quad_data/average missile velocity'])
set_param([sys,'/','Quad_data/average missile velocity'],...
          'orientation',2,...
          'Value','avg_missilelevel'....
          'position',[490,62,595,78])

add_block('built-in/Note',[sys,'/','Quad_data/BLOCK: Quad_data'])
set_param([sys,'/','Quad_data/BLOCK: Quad_data'],...
          'position',[315,235,320,240])
add_line([sys,'/','Quad_data'],[775,150;725,150;725,160;710,160])
add_line([sys,'/','Quad_data'],[155,100;135,100;135,115;105,115])
add_line([sys,'/','Quad_data'],[110,135;105,135])
add_line([sys,'/','Quad_data'],[180,135;175,135])
add_line([sys,'/','Quad_data'],[230,70;220,125])
add_line([sys,'/','Quad_data'],[270,105;265,105;265,140;220,140])
add_line([sys,'/','Quad_data'],[325,120;320,120;320,110;305,110])
add_line([sys,'/','Quad_data'],[485,70;450,70;450,94;325,94;325,100;305,100])
add_line([sys,'/','Quad_data'],[500,110;360,110])
add_line([sys,'/','Quad_data'],[550,165;490,165;490,120;360,120])
add_line([sys,'/','Quad_data'],[415,130;360,130])
add_line([sys,'/','Quad_data'],[675,165;630,165])
add_line([sys,'/','Quad_data'],[600,110;580,110])
add_line([sys,'/','Quad_data'],[725,170;710,170])
add_line([sys,'/','Quad_data'],[835,160;825,160])
add_line([sys,'/','Quad_data'],[1030,150;875,150])
add_line([sys,'/','Quad_data'],[945,195;920,195;920,170;875,170])
add_line([sys,'/','Quad_data'],[70,125;50,125])
add_line([sys,'/','Quad_data'],[995,160;875,160])
add_line([sys,'/','Quad_data'],[775,165;765,210])
set_param([sys,'/','Quad_data'],...
          'Mask Display',' Quradrant\n      time to\n      target \nAC-missile \ntheta
\n  Quadrant\n      launch\n      delay')

% Finished composite block 'Quad_data'.

set_param([sys,'/','Quad_data'],...
          'position',[945,516,1035,609])

% Subsystem 'Fire_timing'.

new_system([sys,'/','Fire_timing'])
set_param([sys,'/','Fire_timing'],'Location',[150,509,1144,901])

```

```

add_block('built-in/Inport',[sys,/, 'Fire_timing/AC-Missile theta'])
set_param([sys,/, 'Fire_timing/AC-Missile theta'],...
    'position',[385,125,405,145])

add_block('built-in/Constant',[sys,/, 'Fire_timing/Launch time safety factor'])
set_param([sys,/, 'Fire_timing/Launch time safety factor'],...
    'Value','launchtime_safetyfactor',...
    'position',[435,85,585,105])

add_block('built-in/Sum',[sys,/, 'Fire_timing/S15'])
set_param([sys,/, 'Fire_timing/S15'],...
    'position',[635,91,655,149])

add_block('built-in/Look Up Table',[sys,/, ['Fire_timing/theta of missile in, ',13,'time to target out']])
set_param([sys,/, ['Fire_timing/theta of missile in, ',13,'time to target out']],...
    'Input_Values','theta_missile_lu',...
    'Output_Values','time_lu',...
    'position',[535,123,565,147])

add_block('built-in/MATLAB Fcn',[sys,/, ['Fire_timing/zerocheck',13,'(u(1)>0)']])
set_param([sys,/, ['Fire_timing/zerocheck',13,'(u(1)>0)']],...
    'MATLAB Fcn','(u(1)>0)',...
    'position',[770,148,840,182])

add_block('built-in/Sum',[sys,/, 'Fire_timing/Sum19'])
set_param([sys,/, 'Fire_timing/Sum19'],...
    'inputs','-+',...
    'position',[730,149,750,176])

add_block('built-in/Constant',[sys,/, 'Fire_timing/rangestd'])
set_param([sys,/, 'Fire_timing/rangestd'],...
    'Value','rangestd',...
    'position',[200,172,265,188])

add_block('built-in/Product',[sys,/, 'Fire_timing/m24'])
set_param([sys,/, 'Fire_timing/m24'],...
    'position',[305,165,330,185])

add_block('built-in/MATLAB Fcn',[sys,/, 'Fire_timing/division.m'])
set_param([sys,/, 'Fire_timing/division.m'],...
    'MATLAB Fcn','division',...
    'Output Width','1',...
    'position',[625,195,675,225])

add_block('built-in/Mux',[sys,/, 'Fire_timing/Mux15'])
set_param([sys,/, 'Fire_timing/Mux15'],...
    'inputs','2',...
    'position',[560,193,590,222])

add_block('built-in/Inport',[sys,/, 'Fire_timing/Relative Velocity'])
set_param([sys,/, 'Fire_timing/Relative Velocity'],...
    'Port','2',...
    'position',[480,205,500,225])

add_block('built-in/Sum',[sys,/, 'Fire_timing/Sum23'])

```

```

set_param([sys,'/','Fire_timing/Sum23'],...
          'inputs','+-',...
          'position',[395,197,420,233])

add_block('built-in/Constant',[sys,'/','Fire_timing/lethaldist_'])
set_param([sys,'/','Fire_timing/lethaldist_'],...
          'Value','lethaldist'...
          'position',[300,218,370,232])

add_block('built-in/Inport',[sys,'/','Fire_timing/AC-Missile',13,'slantrange'])
set_param([sys,'/','Fire_timing/AC-Missile',13,'slantrange'],...
          'Port','3',...
          'position',[250,205,270,225])

add_block('built-in/Outport',[sys,'/','Fire_timing/Fire Flag'])
set_param([sys,'/','Fire_timing/Fire Flag'],...
          'position',[880,155,900,175])

% Subsystem ['Fire_timing/hold6',13,'sample=.25'].

new_system([sys,'/','Fire_timing/hold6',13,'sample=.25'])
set_param([sys,'/','Fire_timing/hold6',13,'sample=.25'],'Location',[511,151,915,322])

add_block('built-in/Zero-Order Hold',[sys,'/','Fire_timing/hold6',13,'sample=.25/Zero-Order',13,'Hold'])
set_param([sys,'/','Fire_timing/hold6',13,'sample=.25/Zero-Order',13,'Hold'],...
          'Sample time','Ts',...
          'position',[100,29,135,61])

add_block('built-in/Gain',[sys,'/','Fire_timing/hold6',13,'sample=.25/Gain'])
set_param([sys,'/','Fire_timing/hold6',13,'sample=.25/Gain'],...
          'Gain','1/Ts',...
          'position',[285,33,325,77])

add_block('built-in/Integrator',[sys,'/','Fire_timing/hold6',13,'sample=.25/Integrator'])
set_param([sys,'/','Fire_timing/hold6',13,'sample=.25/Integrator'],...
          'position',[235,42,260,68])

add_block('built-in/Sum',[sys,'/','Fire_timing/hold6',13,'sample=.25/Sum'])
set_param([sys,'/','Fire_timing/hold6',13,'sample=.25/Sum'],...
          'inputs','+-',...
          'position',[190,37,210,68])

add_block('built-in/Unit Delay',[sys,'/','Fire_timing/hold6',13,'sample=.25/Unit Delay'])
set_param([sys,'/','Fire_timing/hold6',13,'sample=.25/Unit Delay'],...
          'Sample time','Ts',...
          'position',[90,93,140,117])

add_block('built-in/Inport',[sys,'/','Fire_timing/hold6',13,'sample=.25/input'])
set_param([sys,'/','Fire_timing/hold6',13,'sample=.25/input'],...
          'position',[25,35,45,55])

add_block('built-in/Outport',[sys,'/','Fire_timing/hold6',13,'sample=.25/output'])
set_param([sys,'/','Fire_timing/hold6',13,'sample=.25/output'],...
          'position',[345,45,365,65])

```

```

add_line([sys,/,['Fire_timing/hold6',13,'sample=.25']], [330,55;340,55])
add_line([sys,/,['Fire_timing/hold6',13,'sample=.25']], [265,55;280,55])
add_line([sys,/,['Fire_timing/hold6',13,'sample=.25']], [215,55;230,55])
add_line([sys,/,['Fire_timing/hold6',13,'sample=.25']], [145,105;165,105;165,60;185,60])
add_line([sys,/,['Fire_timing/hold6',13,'sample=.25']], [140,45;185,45])
add_line([sys,/,['Fire_timing/hold6',13,'sample=.25']], [50,45;95,45])
add_line([sys,/,['Fire_timing/hold6',13,'sample=.25']], [65,45;65,105;85,105])
set_param([sys,/,['Fire_timing/hold6',13,'sample=.25']],...
    'Mask Display','plot(0,0,100,100,[90,70,50,30,10],[60,40,80,30,20])',...
    'Mask Type','First-Order Hold',...
    'Mask Dialogue','First-Order Hold|Sample Time:')
set_param([sys,/,['Fire_timing/hold6',13,'sample=.25']],...
    'Mask Translate','Ts=@ 1;',...
    'Mask Help','Implements a First-Order sample-and-hold latch operating at the sampling
interval you specify.',...
    'Mask Entries','.25V')

```

```

% Finished composite block ['Fire_timing/hold6',13,'sample=.25'].

```

```

set_param([sys,/,['Fire_timing/hold6',13,'sample=.25']],...
    'position',[130,154,165,186])

```

```

add_block('built-in/White Noise',[sys,/,['Fire_timing/White Noise',13,'7']])
set_param([sys,/,['Fire_timing/White Noise',13,'7']],...
    'Seed',noiseseed(7),...
    'position',[70,160,90,180])

```

```

add_block('built-in/Note',[sys,/,['Fire_timing/BLOCK: Fire_timing']])
set_param([sys,/,['Fire_timing/BLOCK: Fire_timing']],...
    'position',[390,325,395,330])

```

```

add_line([sys,/,['Fire_timing']], [335,175;360,175;360,205;390,205])
add_line([sys,/,['Fire_timing']], [375,225;390,225])
add_line([sys,/,['Fire_timing']], [170,170;300,170])
add_line([sys,/,['Fire_timing']], [270,180;300,180])
add_line([sys,/,['Fire_timing']], [95,170;125,170])
add_line([sys,/,['Fire_timing']], [660,120;685,120;685,155;725,155])
add_line([sys,/,['Fire_timing']], [590,95;615,95;615,105;630,105])
add_line([sys,/,['Fire_timing']], [425,215;445,215;445,200;555,200])
add_line([sys,/,['Fire_timing']], [570,135;630,135])
add_line([sys,/,['Fire_timing']], [755,165;765,165])
add_line([sys,/,['Fire_timing']], [680,210;705,210;705,170;725,170])
add_line([sys,/,['Fire_timing']], [595,210;620,210])
add_line([sys,/,['Fire_timing']], [410,135;530,135])
add_line([sys,/,['Fire_timing']], [845,165;875,165])
add_line([sys,/,['Fire_timing']], [275,215;390,215])
add_line([sys,/,['Fire_timing']], [505,215;555,215])
set_param([sys,/,['Fire_timing']],...

```

```

    'Mask Display','AC-Missile \nTheta \n\nRelative Fire Flag\n Velocity
\nAC-Missile \nslanrange ')

```

```

% Finished composite block 'Fire_timing'.

```

```

set_param([sys,/,['Fire_timing']],...

```

```

        'position',[925,650,1050,740])

add_block('built-in/Constant',[sys,/,['Effective radius ',13,'of expendable2']])
set_param([sys,/,['Effective radius ',13,'of expendable2']],...
    'Value','expeff_radius(2)',...
    'position',[1350,450,1445,470])

add_block('built-in/Constant',[sys,/,['Effective radius ',13,'of expendable1']])
set_param([sys,/,['Effective radius ',13,'of expendable1']],...
    'Value','expeff_radius(1)',...
    'position',[1345,196,1440,214])

% Subsystem 'Expendable1'.

new_system([sys,/, 'Expendable1'])
set_param([sys,/, 'Expendable1'], 'Location', [76,394,1090,889])

add_block('built-in/Inport',[sys,/, ['Expendable1/Missile position',13,'(x,y,z)']])
set_param([sys,/, ['Expendable1/Missile position',13,'(x,y,z)']],...
    'position',[300,475,320,495])

add_block('built-in/Inport',[sys,/, ['Expendable1/effective radius',13,'of expendable']])
set_param([sys,/, ['Expendable1/effective radius',13,'of expendable']],...
    'Port','5',...
    'position',[760,420,780,440])

add_block('built-in/Product',[sys,/, 'Expendable1/Product23'])
set_param([sys,/, 'Expendable1/Product23'],...
    'position',[720,675,745,695])

add_block('built-in/Product',[sys,/, 'Expendable1/Product25'])
set_param([sys,/, 'Expendable1/Product25'],...
    'position',[725,580,750,600])

add_block('built-in/Constant',[sys,/, 'Expendable1/Expendable type'])
set_param([sys,/, 'Expendable1/Expendable type'],...
    'Value','exp_type',...
    'position',[860,434,945,456])

add_block('built-in/Demux',[sys,/, 'Expendable1/Demux5'])
set_param([sys,/, 'Expendable1/Demux5'],...
    'outputs','3',...
    'position',[390,467,430,503])

add_block('built-in/Product',[sys,/, 'Expendable1/Product24'])
set_param([sys,/, 'Expendable1/Product24'],...
    'position',[685,630,710,650])

add_block('built-in/Sum',[sys,/, 'Expendable1/Sum18'])
set_param([sys,/, 'Expendable1/Sum18'],...
    'inputs','+++',...
    'position',[860,622,880,658])

add_block('built-in/Fcn',[sys,/, 'Expendable1/Fcn14'])

```

```

set_param([sys,'/','Expendable1/Fcn14'],...
          'Expr','sqrt(u[1])',...
          'position',[895,629,980,651])

add_block('built-in/Sum',[sys,'/','Expendable1/Sum16'])
set_param([sys,'/','Expendable1/Sum16'],...
          'inputs','+',...
          'position',[540,480,560,500])

add_block('built-in/Sum',[sys,'/','Expendable1/Sum15'])
set_param([sys,'/','Expendable1/Sum15'],...
          'inputs','+',...
          'position',[575,435,595,455])

add_block('built-in/Sum',[sys,'/','Expendable1/Sum17'])
set_param([sys,'/','Expendable1/Sum17'],...
          'inputs','+',...
          'position',[500,525,520,545])

add_block('built-in/Memory',[sys,'/','Expendable1/Memory',13,'IC: 0'])
set_param([sys,'/','Expendable1/Memory',13,'IC: 0'],...
          'position',[1020,665,1060,695])

add_block('built-in/Mux',[sys,'/','Expendable1/Mux11'])
set_param([sys,'/','Expendable1/Mux11'],...
          'inputs','6',...
          'position',[1050,372,1085,473])

add_block('built-in/Memory',[sys,'/','Expendable1/Memory1',13,'IC: 0'])
set_param([sys,'/','Expendable1/Memory1',13,'IC: 0'],...
          'position',[880,325,920,355])

add_block('built-in/Demux',[sys,'/','Expendable1/Demux4'])
set_param([sys,'/','Expendable1/Demux4'],...
          'outputs','2',...
          'position',[1200,405,1240,440])

add_block('built-in/MATLAB Fcn',[sys,'/','Expendable1/mexphit.m'])
set_param([sys,'/','Expendable1/mexphit.m'],...
          'MATLAB Fcn','mexphit',...
          'Output Width','2',...
          'position',[1120,410,1170,440])

add_block('built-in/Demux',[sys,'/','Expendable1/Demux3'])
set_param([sys,'/','Expendable1/Demux3'],...
          'outputs','9')
set_param([sys,'/','Expendable1/Demux3'],...
          'Mask Display',      xexp\n      xvexp\n      yexp\n      vyexp\nexp pos
zexp\n      vzexp\n x pos noise\n y pos noise\n z pos noise')
set_param([sys,'/','Expendable1/Demux3'],...
          'position',[185,138,280,242])

add_block('built-in/Inport',[sys,'/','Expendable1/operational',13,'flag',13,""])
set_param([sys,'/','Expendable1/operational',13,'flag',13,""],...
          'Port','6',...

```

```

        'position',[550,60,570,80])

add_block('built-in/Outport',[sys,/, 'Expendable1/exp pos in1'])
set_param([sys,/, 'Expendable1/exp pos in1'],...
    'Port','2',...
    'position',[540,290,560,310])

add_block('built-in/Outport',[sys,/, 'Expendable1/exp pos in2'])
set_param([sys,/, 'Expendable1/exp pos in2'],...
    'orientation',2,...
    'Port','3',...
    'position',[390,330,410,350])

add_block('built-in/Outport',[sys,/, 'Expendable1/exp pos in3'])
set_param([sys,/, 'Expendable1/exp pos in3'],...
    'orientation',2,...
    'Port','4',...
    'position',[395,380,415,400])

add_block('built-in/Outport',[sys,/, 'Expendable1/STOP Flag'])
set_param([sys,/, 'Expendable1/STOP Flag'],...
    'Port','6',...
    'position',[1295,450,1315,470])

add_block('built-in/Outport',[sys,/, 'Expendable1/PK'])
set_param([sys,/, 'Expendable1/PK'],...
    'Port','5',...
    'position',[1300,405,1320,425])

add_block('built-in/Outport',[sys,/, 'Expendable1/mexslanrange'])
set_param([sys,/, 'Expendable1/mexslanrange'],...
    'Port','7',...
    'position',[1095,630,1115,650])

add_block('built-in/Mux',[sys,/, 'Expendable1/Mux15'])
set_param([sys,/, 'Expendable1/Mux15'],...
    'inputs','6',...
    'position',[370,64,405,136])

add_block('built-in/Outport',[sys,/, ['Expendable1/exp pos',13, '(x,vx,y,vy,z,vz)']])
set_param([sys,/, ['Expendable1/exp pos',13, '(x,vx,y,vy,z,vz)']],...
    'Port','8',...
    'position',[450,90,470,110])

add_block('built-in/Constant',[sys,/, 'Expendable1/Duration of wash noise'])
set_param([sys,/, 'Expendable1/Duration of wash noise'],...
    'Value','washnoiseduration',...
    'position',[710,294,830,316])

add_block('built-in/Memory',[sys,/, ['Expendable1/Memory2',13, 'IC: [0 0 0]']])
set_param([sys,/, ['Expendable1/Memory2',13, 'IC: [0 0 0]']],...
    'x0','[0 0 0]',...
    'position',[700,150,740,180])

add_block('built-in/Inport',[sys,/, 'Expendable1/time'])

```

```

set_param([sys,/, 'Expendable1/time'],...
          'Port', '4',...
          'position', [720, 110, 740, 130])

add_block('built-in/Inport', [sys,/, ['Expendable1/launch', 13, 'flag']])
set_param([sys,/, ['Expendable1/launch', 13, 'flag']],...
          'Port', '2',...
          'position', [645, 80, 665, 100])

add_block('built-in/Mux', [sys,/, 'Expendable1/Mux14'])
set_param([sys,/, 'Expendable1/Mux14'],...
          'inputs', '6',...
          'position', [915, 64, 950, 101])

add_block('built-in/Outport', [sys,/, 'Expendable1/exp pos in'])
set_param([sys,/, 'Expendable1/exp pos in'],...
          'position', [1005, 75, 1025, 95])

add_block('built-in/Constant', [sys,/, 'Expendable1/standard dev of wash noise'])
set_param([sys,/, 'Expendable1/standard dev of wash noise'],...
          'Value', 'washnoisestd',...
          'position', [685, 215, 765, 235])

add_block('built-in/Inport', [sys,/, 'Expendable1/exp pos out'])
set_param([sys,/, 'Expendable1/exp pos out'],...
          'Port', '3',...
          'position', [120, 180, 140, 200])

add_block('built-in/Mux', [sys,/, 'Expendable1/Mux16'])
set_param([sys,/, 'Expendable1/Mux16'],...
          'inputs', '3',...
          'position', [350, 201, 385, 239])
add_line([sys,/, 'Expendable1'], [575, 70; 910, 70])
add_line([sys,/, 'Expendable1'], [745, 120; 745, 80; 910, 80])
add_line([sys,/, 'Expendable1'], [745, 165; 770, 165; 770, 85; 910, 85])
add_line([sys,/, 'Expendable1'], [750, 685; 785, 685; 785, 650; 855, 650])
add_line([sys,/, 'Expendable1'], [755, 590; 770, 590; 770, 630; 855, 630])
add_line([sys,/, 'Expendable1'], [985, 640; 995, 640; 995, 415; 1045, 415])
add_line([sys,/, 'Expendable1'], [435, 485; 535, 485])
add_line([sys,/, 'Expendable1'], [1175, 425; 1195, 425])
add_line([sys,/, 'Expendable1'], [1090, 425; 1115, 425])
add_line([sys,/, 'Expendable1'], [950, 445; 1045, 445])
add_line([sys,/, 'Expendable1'], [885, 640; 890, 640])
add_line([sys,/, 'Expendable1'], [715, 640; 855, 640])
add_line([sys,/, 'Expendable1'], [600, 445; 697, 445; 697, 585; 720, 585])
add_line([sys,/, 'Expendable1'], [600, 445; 697, 445; 697, 595; 720, 595])
add_line([sys,/, 'Expendable1'], [565, 490; 647, 490; 647, 645; 680, 645])
add_line([sys,/, 'Expendable1'], [565, 490; 647, 490; 647, 635; 680, 635])
add_line([sys,/, 'Expendable1'], [525, 535; 612, 535; 612, 680; 715, 680])
add_line([sys,/, 'Expendable1'], [525, 535; 612, 535; 612, 690; 715, 690])
add_line([sys,/, 'Expendable1'], [325, 485; 385, 485])
add_line([sys,/, 'Expendable1'], [785, 430; 1045, 430])
add_line([sys,/, 'Expendable1'], [1065, 680; 1252, 680; 1252, 605; 1032, 605; 1032, 460; 1045, 460])
add_line([sys,/, 'Expendable1'], [435, 495; 457, 495; 457, 530; 495, 530])
add_line([sys,/, 'Expendable1'], [435, 475; 492, 475; 492, 440; 570, 440])

```



```

add_line([sys,'','Expendable1'],[985,640;995,640;995,680;1015,680])
add_line([sys,'','Expendable1'],[285,150;505,150;505,450;570,450])
add_line([sys,'','Expendable1'],[285,170;477,170;477,495;535,495])
add_line([sys,'','Expendable1'],[285,190;447,190;447,540;495,540])
add_line([sys,'','Expendable1'],[670,90;717,90;717,75;910,75])
add_line([sys,'','Expendable1'],[610,70;610,400;1045,400])
add_line([sys,'','Expendable1'],[842,400;842,340;875,340])
add_line([sys,'','Expendable1'],[925,340;982,340;982,385;1045,385])
add_line([sys,'','Expendable1'],[955,85;1000,85])
add_line([sys,'','Expendable1'],[145,190;180,190])
add_line([sys,'','Expendable1'],[1245,415;1295,415])
add_line([sys,'','Expendable1'],[1245,430;1270,430;1270,460;1290,460])
add_line([sys,'','Expendable1'],[505,300;535,300])
add_line([sys,'','Expendable1'],[447,390;420,390])
add_line([sys,'','Expendable1'],[477,340;415,340])
add_line([sys,'','Expendable1'],[995,640;1090,640])
add_line([sys,'','Expendable1'],[410,100;445,100])
add_line([sys,'','Expendable1'],[285,150;305,150;305,75;365,75])
add_line([sys,'','Expendable1'],[285,160;310,160;310,85;365,85])
add_line([sys,'','Expendable1'],[320,170;320,95;365,95])
add_line([sys,'','Expendable1'],[285,180;325,180;325,105;365,105])
add_line([sys,'','Expendable1'],[330,190;330,115;365,115])
add_line([sys,'','Expendable1'],[835,305;885,305;885,95;910,95])
add_line([sys,'','Expendable1'],[285,210;345,210])
add_line([sys,'','Expendable1'],[285,220;345,220])
add_line([sys,'','Expendable1'],[285,230;345,230])
add_line([sys,'','Expendable1'],[390,220;560,220;560,165;695,165])
add_line([sys,'','Expendable1'],[770,225;780,225;780,180;875,180;875,90;910,90])
add_line([sys,'','Expendable1'],[285,200;335,200;335,125;365,125])
set_param([sys,'','Expendable1'],...
'Mask Display','Missile   exppos in\nnpos (x,y,z)           \n          Exp X pos\n
Launch Flag      \n          Exp Y pos\nexp pos           \n out          Exp Z pos\n\nTime
PK\n             Stop flag\nEffective           \nradius  mexslanrange\n\nOperational       \nflag
Exp pos (x,y,z)')

```

```

% Finished composite block 'Expendable1'.

```

```

set_param([sys,'','Expendable1'],...
'position',[1480,71,1615,249])

```

```

% Subsystem 'Expendable2'.

```

```

new_system([sys,'','Expendable2'])
set_param([sys,'','Expendable2'],'Location',[66,344,1080,839])

```

```

add_block('built-in/Inport',[sys,'','Expendable2/Missile position'.13,'(x,y,z)'])
set_param([sys,'','Expendable2/Missile position'.13,'(x,y,z)'],...
'position',[300,475,320,495])

```

```

add_block('built-in/Inport',[sys,'','Expendable2/effective radius'.13,'of expendable'])
set_param([sys,'','Expendable2/effective radius'.13,'of expendable'],...
'Port','S'....
'position',[760,420,780,440])

```

```

add_block('built-in/Product',[sys,/, 'Expendable2/Product23'])
set_param([sys,/, 'Expendable2/Product23'],...
          'position',[720,675,745,695])

add_block('built-in/Product',[sys,/, 'Expendable2/Product25'])
set_param([sys,/, 'Expendable2/Product25'],...
          'position',[725,580,750,600])

add_block('built-in/Constant',[sys,/, 'Expendable2/Expendable type'])
set_param([sys,/, 'Expendable2/Expendable type'],...
          'Value','exp_type'...
          'position',[860,434,945,456])

add_block('built-in/Demux',[sys,/, 'Expendable2/Demux5'])
set_param([sys,/, 'Expendable2/Demux5'],...
          'outputs','3',...
          'position',[390,467,430,503])

add_block('built-in/Product',[sys,/, 'Expendable2/Product24'])
set_param([sys,/, 'Expendable2/Product24'],...
          'position',[685,630,710,650])

add_block('built-in/Sum',[sys,/, 'Expendable2/Sum18'])
set_param([sys,/, 'Expendable2/Sum18'],...
          'inputs','+++',...
          'position',[860,622,880,658])

add_block('built-in/Fcn',[sys,/, 'Expendable2/Fcn14'])
set_param([sys,/, 'Expendable2/Fcn14'],...
          'Expr','sqrt(u[1])',...
          'position',[895,629,980,651])

add_block('built-in/Sum',[sys,/, 'Expendable2/Sum16'])
set_param([sys,/, 'Expendable2/Sum16'],...
          'inputs','+',...
          'position',[540,480,560,500])

add_block('built-in/Sum',[sys,/, 'Expendable2/Sum15'])
set_param([sys,/, 'Expendable2/Sum15'],...
          'inputs','+',...
          'position',[575,435,595,455])

add_block('built-in/Sum',[sys,/, 'Expendable2/Sum17'])
set_param([sys,/, 'Expendable2/Sum17'],...
          'inputs','+',...
          'position',[500,525,520,545])

add_block('built-in/Memory',[sys,/, ['Expendable2/Memory',13,'IC: 0']])
set_param([sys,/, ['Expendable2/Memory',13,'IC: 0']],...
          'position',[1020,665,1060,695])

add_block('built-in/Mux',[sys,/, 'Expendable2/Mux11'])
set_param([sys,/, 'Expendable2/Mux11'],...
          'inputs','6',...

```

```

'position',[1050,372,1085,473])

add_block('built-in/Memory',[sys,/,['Expendable2/Memory1',13,IC: 0]])
set_param([sys,/,['Expendable2/Memory1',13,IC: 0]],...
'position',[880,325,920,355])

add_block('built-in/Demux',[sys,/,Expendable2/Demux4'])
set_param([sys,/,Expendable2/Demux4'],...
'outputs',2,...
'position',[1200,405,1240,440])

add_block('built-in/MATLAB Fcn',[sys,/,Expendable2/mexphit.m'])
set_param([sys,/,Expendable2/mexphit.m'],...
'MATLAB Fcn','mexphit'...
'Output Width',2,...
'position',[1120,410,1170,440])

add_block('built-in/Demux',[sys,/,Expendable2/Demux3'])
set_param([sys,/,Expendable2/Demux3'],...
'outputs','9')
set_param([sys,/,Expendable2/Demux3'],...
'Mask Display', xexp\n xvexp\n yexp\n vyexp\nexp pos
zexp\n vexp\n x pos noise\n y pos noise\n z pos noise')
set_param([sys,/,Expendable2/Demux3'],...
'position',[185,138,280,242])

add_block('built-in/Inport',[sys,/,['Expendable2/operational',13,'flag',13,]])
set_param([sys,/,['Expendable2/operational',13,'flag',13,]],...
'Port','6',...
'position',[550,60,570,80])

add_block('built-in/Outport',[sys,/,Expendable2/exp pos in1'])
set_param([sys,/,Expendable2/exp pos in1'],...
'Port','2',...
'position',[540,290,560,310])

add_block('built-in/Outport',[sys,/,Expendable2/exp pos in2'])
set_param([sys,/,Expendable2/exp pos in2'],...
'orientation',2,...
'Port','3',...
'position',[390,330,410,350])

add_block('built-in/Outport',[sys,/,Expendable2/exp pos in3'])
set_param([sys,/,Expendable2/exp pos in3'],...
'orientation',2,...
'Port','4',...
'position',[395,380,415,400])

add_block('built-in/Outport',[sys,/,Expendable2/STOP Flag'])
set_param([sys,/,Expendable2/STOP Flag'],...
'Port','6',...
'position',[1295,450,1315,470])

add_block('built-in/Outport',[sys,/,Expendable2/PK'])
set_param([sys,/,Expendable2/PK'],...

```

```

        'Port','5',...
        'position',[1300,405,1320,425])

add_block('built-in/Outport',[sys,/, 'Expendable2/mexslantrange'])
set_param([sys,/, 'Expendable2/mexslantrange'],...
        'Port','7',...
        'position',[1095,630,1115,650])

add_block('built-in/Mux',[sys,/, 'Expendable2/Mux15'])
set_param([sys,/, 'Expendable2/Mux15'],...
        'inputs','6',...
        'position',[370,64,405,136])

add_block('built-in/Outport',[sys,/, ['Expendable2/exp pos',13,'(x,vx,y,vy,z,vz)']]
set_param([sys,/, ['Expendable2/exp pos',13,'(x,vx,y,vy,z,vz)']],...
        'Port','8',...
        'position',[450,90,470,110])

add_block('built-in/Constant',[sys,/, 'Expendable2/Duration of wash noise'])
set_param([sys,/, 'Expendable2/Duration of wash noise'],...
        'Value','washnoiseduration',...
        'position',[710,294,830,316])

add_block('built-in/Memory',[sys,/, ['Expendable2/Memory2',13, 'IC: [0 0 0]']]
set_param([sys,/, ['Expendable2/Memory2',13, 'IC: [0 0 0]']],...
        'x0',[0 0 0],...
        'position',[700,150,740,180])

add_block('built-in/Inport',[sys,/, 'Expendable2/time'])
set_param([sys,/, 'Expendable2/time'],...
        'Port','4',...
        'position',[720,110,740,130])

add_block('built-in/Inport',[sys,/, ['Expendable2/launch',13, 'flag']]
set_param([sys,/, ['Expendable2/launch',13, 'flag']],...
        'Port','2',...
        'position',[645,80,665,100])

add_block('built-in/Mux',[sys,/, 'Expendable2/Mux14'])
set_param([sys,/, 'Expendable2/Mux14'],...
        'inputs','6',...
        'position',[915,64,950,101])

add_block('built-in/Outport',[sys,/, 'Expendable2/exp pos in'])
set_param([sys,/, 'Expendable2/exp pos in'],...
        'position',[1005,75,1025,95])

add_block('built-in/Constant',[sys,/, 'Expendable2/standard dev of wash noise'])
set_param([sys,/, 'Expendable2/standard dev of wash noise'],...
        'Value','washnoisestd',...
        'position',[685,215,765,235])

add_block('built-in/Inport',[sys,/, 'Expendable2/exp pos out'])
set_param([sys,/, 'Expendable2/exp pos out'],...
        'Port','3',...

```

```

'position',[120,180,140,200])

add_block('built-in/Mux',[sys,/, 'Expendable2/Mux16'])
set_param([sys,/, 'Expendable2/Mux16'],...
'inputs',3',...
'position',[350,201,385,239])
add_line([sys,/, 'Expendable2'],[575,70;910,70])
add_line([sys,/, 'Expendable2'],[745,120;745,80;910,80])
add_line([sys,/, 'Expendable2'],[745,165;770,165;770,85;910,85])
add_line([sys,/, 'Expendable2'],[750,685;785,685;785,650;855,650])
add_line([sys,/, 'Expendable2'],[755,590;770,590;770,630;855,630])
add_line([sys,/, 'Expendable2'],[985,640;995,640;995,415;1045,415])
add_line([sys,/, 'Expendable2'],[435,485;535,485])
add_line([sys,/, 'Expendable2'],[1175,425;1195,425])
add_line([sys,/, 'Expendable2'],[1090,425;1115,425])
add_line([sys,/, 'Expendable2'],[950,445;1045,445])
add_line([sys,/, 'Expendable2'],[885,640;890,640])
add_line([sys,/, 'Expendable2'],[715,640;855,640])
add_line([sys,/, 'Expendable2'],[600,445;697,445;697,585;720,585])
add_line([sys,/, 'Expendable2'],[600,445;697,445;697,595;720,595])
add_line([sys,/, 'Expendable2'],[565,490;647,490;647,645;680,645])
add_line([sys,/, 'Expendable2'],[565,490;647,490;647,635;680,635])
add_line([sys,/, 'Expendable2'],[525,535;612,535;612,680;715,680])
add_line([sys,/, 'Expendable2'],[525,535;612,535;612,690;715,690])
add_line([sys,/, 'Expendable2'],[325,485;385,485])
add_line([sys,/, 'Expendable2'],[785,430;1045,430])
add_line([sys,/, 'Expendable2'],[1065,680;1252,680;1252,605;1032,605;1032,460;1045,460])
add_line([sys,/, 'Expendable2'],[435,495;457,495;457,530;495,530])
add_line([sys,/, 'Expendable2'],[435,475;492,475;492,440;570,440])
add_line([sys,/, 'Expendable2'],[985,640;995,640;995,680;1015,680])
add_line([sys,/, 'Expendable2'],[285,150;505,150;505,450;570,450])
add_line([sys,/, 'Expendable2'],[285,170;477,170;477,495;535,495])
add_line([sys,/, 'Expendable2'],[285,190;447,190;447,540;495,540])
add_line([sys,/, 'Expendable2'],[670,90;717,90;717,75;910,75])
add_line([sys,/, 'Expendable2'],[610,70;610,400;1045,400])
add_line([sys,/, 'Expendable2'],[842,400;842,340;875,340])
add_line([sys,/, 'Expendable2'],[925,340;982,340;982,385;1045,385])
add_line([sys,/, 'Expendable2'],[955,85;1000,85])
add_line([sys,/, 'Expendable2'],[145,190;180,190])
add_line([sys,/, 'Expendable2'],[1245,415;1295,415])
add_line([sys,/, 'Expendable2'],[1245,430;1270,430;1270,460;1290,460])
add_line([sys,/, 'Expendable2'],[505,300;535,300])
add_line([sys,/, 'Expendable2'],[447,390;420,390])
add_line([sys,/, 'Expendable2'],[477,340;415,340])
add_line([sys,/, 'Expendable2'],[995,640;1090,640])
add_line([sys,/, 'Expendable2'],[410,100;445,100])
add_line([sys,/, 'Expendable2'],[285,150;305,150;305,75;365,75])
add_line([sys,/, 'Expendable2'],[285,160;310,160;310,85;365,85])
add_line([sys,/, 'Expendable2'],[320,170;320,95;365,95])
add_line([sys,/, 'Expendable2'],[285,180;325,180;325,105;365,105])
add_line([sys,/, 'Expendable2'],[330,190;330,115;365,115])
add_line([sys,/, 'Expendable2'],[835,305;885,305;885,95;910,95])
add_line([sys,/, 'Expendable2'],[285,210;345,210])
add_line([sys,/, 'Expendable2'],[285,220;345,220])
add_line([sys,/, 'Expendable2'],[285,230;345,230])

```

```

add_line([sys,'','Expendable2'],[390,220;560,220;560,165;695,165])
add_line([sys,'','Expendable2'],[770,225;780,225;780,180;875,180;875,90;910,90])
add_line([sys,'','Expendable2'],[285,200;335,200;335,125;365,125])
set_param([sys,'','Expendable2'],...
    'Mask Display','Missile   exppos in\npos (x,y,z)           \n           Exp X pos\n
Launch Flag           \n           Exp Y pos\nexp pos           \n out           Exp Z pos\n\nTime
PK\n                 Stop flag\nEffective           \nradius  mexslanrange\n\nOperational           \nflag
Exp pos (x,y,z)')

```

```

% Finished composite block 'Expendable2'.

```

```

set_param([sys,'','Expendable2'],...
    'position',[1510,326,1645,504])

```

```

% Subsystem 'Expendable3'.

```

```

new_system([sys,'','Expendable3'])
set_param([sys,'','Expendable3'],'Location',[66,344,1080,839])

```

```

add_block('built-in/Inport',[sys,'','Expendable3/Missile position',13,'(x,y,z)'])
set_param([sys,'','Expendable3/Missile position',13,'(x,y,z)'],...
    'position',[300,475,320,495])

```

```

add_block('built-in/Inport',[sys,'','Expendable3/effective radius',13,'of expendable'])
set_param([sys,'','Expendable3/effective radius',13,'of expendable'],...
    'Port','5',...
    'position',[760,420,780,440])

```

```

add_block('built-in/Product',[sys,'','Expendable3/Product23'])
set_param([sys,'','Expendable3/Product23'],...
    'position',[720,675,745,695])

```

```

add_block('built-in/Product',[sys,'','Expendable3/Product25'])
set_param([sys,'','Expendable3/Product25'],...
    'position',[725,580,750,600])

```

```

add_block('built-in/Constant',[sys,'','Expendable3/Expendable type'])
set_param([sys,'','Expendable3/Expendable type'],...
    'Value','exp_type',...
    'position',[860,434,945,456])

```

```

add_block('built-in/Demux',[sys,'','Expendable3/Demux5'])
set_param([sys,'','Expendable3/Demux5'],...
    'outputs','3',...
    'position',[390,467,430,503])

```

```

add_block('built-in/Product',[sys,'','Expendable3/Product24'])
set_param([sys,'','Expendable3/Product24'],...
    'position',[685,630,710,650])

```

```

add_block('built-in/Sum',[sys,'','Expendable3/Sum18'])
set_param([sys,'','Expendable3/Sum18'],...
    'inputs','+++',...

```

```

'position',[860,622,880,658])

add_block('built-in/Fcn',[sys,/, 'Expendable3/Fcn14'])
set_param([sys,/, 'Expendable3/Fcn14'],...
    'Expr','sqrt(u[1])',...
    'position',[895,629,980,651])

add_block('built-in/Sum',[sys,/, 'Expendable3/Sum16'])
set_param([sys,/, 'Expendable3/Sum16'],...
    'inputs','+',...
    'position',[540,480,560,500])

add_block('built-in/Sum',[sys,/, 'Expendable3/Sum15'])
set_param([sys,/, 'Expendable3/Sum15'],...
    'inputs','+',...
    'position',[575,435,595,455])

add_block('built-in/Sum',[sys,/, 'Expendable3/Sum17'])
set_param([sys,/, 'Expendable3/Sum17'],...
    'inputs','+',...
    'position',[500,525,520,545])

add_block('built-in/Memory',[sys,/, ['Expendable3/Memory',13,'IC: 0']])
set_param([sys,/, ['Expendable3/Memory',13,'IC: 0']],...
    'position',[1020,665,1060,695])

add_block('built-in/Mux',[sys,/, 'Expendable3/Mux11'])
set_param([sys,/, 'Expendable3/Mux11'],...
    'inputs','6',...
    'position',[1050,372,1085,473])

add_block('built-in/Memory',[sys,/, ['Expendable3/Memory1',13,'IC: 0']])
set_param([sys,/, ['Expendable3/Memory1',13,'IC: 0']],...
    'position',[880,325,920,355])

add_block('built-in/Demux',[sys,/, 'Expendable3/Demux4'])
set_param([sys,/, 'Expendable3/Demux4'],...
    'outputs','2',...
    'position',[1200,405,1240,440])

add_block('built-in/MATLAB Fcn',[sys,/, 'Expendable3/mexphit.m'])
set_param([sys,/, 'Expendable3/mexphit.m'],...
    'MATLAB Fcn','mexphit',...
    'Output Width','2',...
    'position',[1120,410,1170,440])

add_block('built-in/Demux',[sys,/, 'Expendable3/Demux3'])
set_param([sys,/, 'Expendable3/Demux3'],...
    'outputs','9')
set_param([sys,/, 'Expendable3/Demux3'],...
    'Mask Display',      xexp\n      xvexp\n      yexp\n      vyexp\nexp pos
zexp\n      vzexp\n      x pos noise\n      y pos noise\n      z pos noise')
set_param([sys,/, 'Expendable3/Demux3'],...
    'position',[185,138,280,242])

```

```

add_block('built-in/Inport',[sys,/,['Expendable3/operational',13,'flag',13,]])
set_param([sys,/,['Expendable3/operational',13,'flag',13,]],...
          'Port','6',...
          'position',[550,60,570,80])

add_block('built-in/Outport',[sys,/, 'Expendable3/exp pos in1'])
set_param([sys,/, 'Expendable3/exp pos in1'],...
          'Port','2',...
          'position',[540,290,560,310])

add_block('built-in/Outport',[sys,/, 'Expendable3/exp pos in2'])
set_param([sys,/, 'Expendable3/exp pos in2'],...
          'orientation',2,...
          'Port','3',...
          'position',[390,330,410,350])

add_block('built-in/Outport',[sys,/, 'Expendable3/exp pos in3'])
set_param([sys,/, 'Expendable3/exp pos in3'],...
          'orientation',2,...
          'Port','4',...
          'position',[395,380,415,400])

add_block('built-in/Outport',[sys,/, 'Expendable3/STOP Flag'])
set_param([sys,/, 'Expendable3/STOP Flag'],...
          'Port','6',...
          'position',[1295,450,1315,470])

add_block('built-in/Outport',[sys,/, 'Expendable3/PK'])
set_param([sys,/, 'Expendable3/PK'],...
          'Port','5',...
          'position',[1300,405,1320,425])

add_block('built-in/Outport',[sys,/, 'Expendable3/mexslanrange'])
set_param([sys,/, 'Expendable3/mexslanrange'],...
          'Port','7',...
          'position',[1095,630,1115,650])

add_block('built-in/Mux',[sys,/, 'Expendable3/Mux 15'])
set_param([sys,/, 'Expendable3/Mux 15'],...
          'inputs','6',...
          'position',[370,64,405,136])

add_block('built-in/Outport',[sys,/, ['Expendable3/exp pos',13, '(x,vx,y,vy,z,vz)']])
set_param([sys,/, ['Expendable3/exp pos',13, '(x,vx,y,vy,z,vz)']],...
          'Port','8',...
          'position',[450,90,470,110])

add_block('built-in/Constant',[sys,/, 'Expendable3/Duration of wash noise'])
set_param([sys,/, 'Expendable3/Duration of wash noise'],...
          'Value','washnoiseduration',...
          'position',[710,294,830,316])

add_block('built-in/Memory',[sys,/, ['Expendable3/Memory2',13, 'IC: [0 0 0]']])
set_param([sys,/, ['Expendable3/Memory2',13, 'IC: [0 0 0]']],...
          'x0','[0 0 0]',...

```



```

        'position',[700,150,740,180])

add_block('built-in/Inport',[sys,/, 'Expendable3/time'])
set_param([sys,/, 'Expendable3/time'],...
    'Port','4',...
    'position',[720,110,740,130])

add_block('built-in/Inport',[sys,/, ['Expendable3/launch',13,'flag']])
set_param([sys,/, ['Expendable3/launch',13,'flag']],...
    'Port','2',...
    'position',[645,80,665,100])

add_block('built-in/Mux',[sys,/, 'Expendable3/Mux14'])
set_param([sys,/, 'Expendable3/Mux14'],...
    'inputs','6',...
    'position',[915,64,950,101])

add_block('built-in/Outport',[sys,/, 'Expendable3/exp pos in'])
set_param([sys,/, 'Expendable3/exp pos in'],...
    'position',[1005,75,1025,95])

add_block('built-in/Constant',[sys,/, 'Expendable3/standard dev of wash noise'])
set_param([sys,/, 'Expendable3/standard dev of wash noise'],...
    'Value','washnoisestd',...
    'position',[685,215,765,235])

add_block('built-in/Inport',[sys,/, 'Expendable3/exp pos out'])
set_param([sys,/, 'Expendable3/exp pos out'],...
    'Port','3',...
    'position',[120,180,140,200])

add_block('built-in/Mux',[sys,/, 'Expendable3/Mux16'])
set_param([sys,/, 'Expendable3/Mux16'],...
    'inputs','3',...
    'position',[350,201,385,239])
add_line([sys,/, 'Expendable3'],[575,70;910,70])
add_line([sys,/, 'Expendable3'],[745,120;745,80;910,80])
add_line([sys,/, 'Expendable3'],[745,165;770,165;770,85;910,85])
add_line([sys,/, 'Expendable3'],[750,685;785,685;785,650;855,650])
add_line([sys,/, 'Expendable3'],[755,590;770,590;770,630;855,630])
add_line([sys,/, 'Expendable3'],[985,640;995,640;995,415;1045,415])
add_line([sys,/, 'Expendable3'],[435,485;535,485])
add_line([sys,/, 'Expendable3'],[1175,425;1195,425])
add_line([sys,/, 'Expendable3'],[1090,425;1115,425])
add_line([sys,/, 'Expendable3'],[950,445;1045,445])
add_line([sys,/, 'Expendable3'],[885,640;890,640])
add_line([sys,/, 'Expendable3'],[715,640;855,640])
add_line([sys,/, 'Expendable3'],[600,445;697,445;697,585;720,585])
add_line([sys,/, 'Expendable3'],[600,445;697,445;697,595;720,595])
add_line([sys,/, 'Expendable3'],[565,490;647,490;647,645;680,645])
add_line([sys,/, 'Expendable3'],[565,490;647,490;647,635;680,635])
add_line([sys,/, 'Expendable3'],[525,535;612,535;612,680;715,680])
add_line([sys,/, 'Expendable3'],[525,535;612,535;612,690;715,690])
add_line([sys,/, 'Expendable3'],[325,485;385,485])
add_line([sys,/, 'Expendable3'],[785,430;1045,430])

```

```

add_line([sys,'','Expendable3'],[1065,680;1252,680;1252,605;1032,605;1032,460;1045,460])
add_line([sys,'','Expendable3'],[435,495;457,495;457,530;495,530])
add_line([sys,'','Expendable3'],[435,475;492,475;492,440;570,440])
add_line([sys,'','Expendable3'],[985,640;995,640;995,680;1015,680])
add_line([sys,'','Expendable3'],[285,150;505,150;505,450;570,450])
add_line([sys,'','Expendable3'],[285,170;477,170;477,495;535,495])
add_line([sys,'','Expendable3'],[285,190;447,190;447,540;495,540])
add_line([sys,'','Expendable3'],[670,90;717,90;717,75;910,75])
add_line([sys,'','Expendable3'],[610,70;610,400;1045,400])
add_line([sys,'','Expendable3'],[842,400;842,340;875,340])
add_line([sys,'','Expendable3'],[925,340;982,340;982,385;1045,385])
add_line([sys,'','Expendable3'],[955,85;1000,85])
add_line([sys,'','Expendable3'],[145,190;180,190])
add_line([sys,'','Expendable3'],[1245,415;1295,415])
add_line([sys,'','Expendable3'],[1245,430;1270,430;1270,460;1290,460])
add_line([sys,'','Expendable3'],[505,300;535,300])
add_line([sys,'','Expendable3'],[447,390;420,390])
add_line([sys,'','Expendable3'],[477,340;415,340])
add_line([sys,'','Expendable3'],[995,640;1090,640])
add_line([sys,'','Expendable3'],[410,100;445,100])
add_line([sys,'','Expendable3'],[285,150;305,150;305,75;365,75])
add_line([sys,'','Expendable3'],[285,160;310,160;310,85;365,85])
add_line([sys,'','Expendable3'],[320,170;320,95;365,95])
add_line([sys,'','Expendable3'],[285,180;325,180;325,105;365,105])
add_line([sys,'','Expendable3'],[330,190;330,115;365,115])
add_line([sys,'','Expendable3'],[835,305;885,305;885,95;910,95])
add_line([sys,'','Expendable3'],[285,210;345,210])
add_line([sys,'','Expendable3'],[285,220;345,220])
add_line([sys,'','Expendable3'],[285,230;345,230])
add_line([sys,'','Expendable3'],[390,220;560,220;560,165;695,165])
add_line([sys,'','Expendable3'],[770,225;780,225;780,180;875,180;875,90;910,90])
add_line([sys,'','Expendable3'],[285,200;335,200;335,125;365,125])
set_param([sys,'','Expendable3'],...
    'Mask Display','Missile   exppos in\nnpos (x,y,z)         \n          Exp X pos\n
Launch Flag          \n          Exp Y pos\nexp pos          \n out          Exp Z pos\n\nTime
PK\n                Stop flag\nEffective          \nradius  mexslanrange\n\nOperational          \nflag
Exp pos (x,y,z)')

```

```
% Finished composite block 'Expendable3'.
```

```
set_param([sys,'','Expendable3'],...
    'position',[1560,581,1695,759])
```

```
% Subsystem 'Expendable6'.
```

```
new_system([sys,'','Expendable6'])
set_param([sys,'','Expendable6'],'Location',[66,344,1080,839])
```

```
add_block('built-in/Inport',[sys,'',['Expendable6/Missile position',13,'(x,y,z)'])
set_param([sys,'',['Expendable6/Missile position',13,'(x,y,z)']],...
    'position',[300,475,320,495])
```

```
add_block('built-in/Inport',[sys,'',['Expendable6/effective radius',13,'of expendable']])
```

```

set_param([sys, '/', 'Expendable6/effective radius', 13, 'of expendable'], ...
    'Port', '5', ...
    'position', [760, 420, 780, 440])

add_block('built-in/Product', [sys, '/', 'Expendable6/Product23'])
set_param([sys, '/', 'Expendable6/Product23'], ...
    'position', [720, 675, 745, 695])

add_block('built-in/Product', [sys, '/', 'Expendable6/Product25'])
set_param([sys, '/', 'Expendable6/Product25'], ...
    'position', [725, 580, 750, 600])

add_block('built-in/Constant', [sys, '/', 'Expendable6/Expendable type'])
set_param([sys, '/', 'Expendable6/Expendable type'], ...
    'Value', 'exp_type', ...
    'position', [860, 434, 945, 456])

add_block('built-in/Demux', [sys, '/', 'Expendable6/Demux5'])
set_param([sys, '/', 'Expendable6/Demux5'], ...
    'outputs', '3', ...
    'position', [390, 467, 430, 503])

add_block('built-in/Product', [sys, '/', 'Expendable6/Product24'])
set_param([sys, '/', 'Expendable6/Product24'], ...
    'position', [685, 630, 710, 650])

add_block('built-in/Sum', [sys, '/', 'Expendable6/Sum18'])
set_param([sys, '/', 'Expendable6/Sum18'], ...
    'inputs', '+++', ...
    'position', [860, 622, 880, 658])

add_block('built-in/Fcn', [sys, '/', 'Expendable6/Fcn14'])
set_param([sys, '/', 'Expendable6/Fcn14'], ...
    'Expr', 'sqrt(u[1])', ...
    'position', [895, 629, 980, 651])

add_block('built-in/Sum', [sys, '/', 'Expendable6/Sum16'])
set_param([sys, '/', 'Expendable6/Sum16'], ...
    'inputs', '+', ...
    'position', [540, 480, 560, 500])

add_block('built-in/Sum', [sys, '/', 'Expendable6/Sum15'])
set_param([sys, '/', 'Expendable6/Sum15'], ...
    'inputs', '+-', ...
    'position', [575, 435, 595, 455])

add_block('built-in/Sum', [sys, '/', 'Expendable6/Sum17'])
set_param([sys, '/', 'Expendable6/Sum17'], ...
    'inputs', '+-', ...
    'position', [500, 525, 520, 545])

add_block('built-in/Memory', [sys, '/', 'Expendable6/Memory', 13, 'IC: 0'])
set_param([sys, '/', 'Expendable6/Memory', 13, 'IC: 0'], ...
    'position', [1020, 665, 1060, 695])

```

```

add_block('built-in/Mux',[sys,/, 'Expendable6/Mux11'])
set_param([sys,/, 'Expendable6/Mux11'],...
          'inputs','6',...
          'position',[1050,372,1085,473])

add_block('built-in/Memory',[sys,/, ['Expendable6/Memory1',13,'IC: 0']])
set_param([sys,/, ['Expendable6/Memory1',13,'IC: 0']],...
          'position',[880,325,920,355])

add_block('built-in/Demux',[sys,/, 'Expendable6/Demux4'])
set_param([sys,/, 'Expendable6/Demux4'],...
          'outputs','2',...
          'position',[1200,405,1240,440])

add_block('built-in/MATLAB Fcn',[sys,/, 'Expendable6/mexphit.m'])
set_param([sys,/, 'Expendable6/mexphit.m'],...
          'MATLAB Fcn','mexphit',...
          'Output Width','2',...
          'position',[1120,410,1170,440])

add_block('built-in/Demux',[sys,/, 'Expendable6/Demux3'])
set_param([sys,/, 'Expendable6/Demux3'],...
          'outputs','9')
set_param([sys,/, 'Expendable6/Demux3'],...
          'Mask Display',      xexp\n      xvexp\n      yexp\n      vyexp\nexp pos
zexp\n      vzexp\n x pos noise\n y pos noise\n z pos noise')
set_param([sys,/, 'Expendable6/Demux3'],...
          'position',[185,138,280,242])

add_block('built-in/Inport',[sys,/, ['Expendable6/operational',13,'flag',13,""]])
set_param([sys,/, ['Expendable6/operational',13,'flag',13,""]],...
          'Port','6',...
          'position',[550,60,570,80])

add_block('built-in/Outport',[sys,/, 'Expendable6/exp pos in1'])
set_param([sys,/, 'Expendable6/exp pos in1'],...
          'Port','2',...
          'position',[540,290,560,310])

add_block('built-in/Outport',[sys,/, 'Expendable6/exp pos in2'])
set_param([sys,/, 'Expendable6/exp pos in2'],...
          'orientation',2,...
          'Port','3',...
          'position',[390,330,410,350])

add_block('built-in/Outport',[sys,/, 'Expendable6/exp pos in3'])
set_param([sys,/, 'Expendable6/exp pos in3'],...
          'orientation',2,...
          'Port','4',...
          'position',[395,380,415,400])

add_block('built-in/Outport',[sys,/, 'Expendable6/STOP Flag'])
set_param([sys,/, 'Expendable6/STOP Flag'],...
          'Port','6',...
          'position',[1295,450,1315,470])

```

```

add_block('built-in/Outport',[sys,'/','Expendable6/PK'])
set_param([sys,'/','Expendable6/PK'],...
    'Port','5',...
    'position',[1300,405,1320,425])

add_block('built-in/Outport',[sys,'/','Expendable6/mexslanrange'])
set_param([sys,'/','Expendable6/mexslanrange'],...
    'Port','7',...
    'position',[1095,630,1115,650])

add_block('built-in/Mux',[sys,'/','Expendable6/Mux15'])
set_param([sys,'/','Expendable6/Mux15'],...
    'inputs','6',...
    'position',[370,64,405,136])

add_block('built-in/Outport',[sys,'/','Expendable6/exp pos',13,'(x,vx,y,vy,z,vz)'])
set_param([sys,'/','Expendable6/exp pos',13,'(x,vx,y,vy,z,vz)'],...
    'Port','8',...
    'position',[450,90,470,110])

add_block('built-in/Constant',[sys,'/','Expendable6/Duration of wash noise'])
set_param([sys,'/','Expendable6/Duration of wash noise'],...
    'Value','washnoiseduration',...
    'position',[710,294,830,316])

add_block('built-in/Memory',[sys,'/','Expendable6/Memory2',13,'IC: [0 0 0]'])
set_param([sys,'/','Expendable6/Memory2',13,'IC: [0 0 0]'],...
    'x0','[0 0 0]',...
    'position',[700,150,740,180])

add_block('built-in/Inport',[sys,'/','Expendable6/time'])
set_param([sys,'/','Expendable6/time'],...
    'Port','4',...
    'position',[720,110,740,130])

add_block('built-in/Inport',[sys,'/','Expendable6/launch',13,'flag'])
set_param([sys,'/','Expendable6/launch',13,'flag'],...
    'Port','2',...
    'position',[645,80,665,100])

add_block('built-in/Mux',[sys,'/','Expendable6/Mux14'])
set_param([sys,'/','Expendable6/Mux14'],...
    'inputs','6',...
    'position',[915,64,950,101])

add_block('built-in/Outport',[sys,'/','Expendable6/exp pos in'])
set_param([sys,'/','Expendable6/exp pos in'],...
    'position',[1005,75,1025,95])

add_block('built-in/Constant',[sys,'/','Expendable6/standard dev of wash noise'])
set_param([sys,'/','Expendable6/standard dev of wash noise'],...
    'Value','washnoisestd',...
    'position',[685,215,765,235])

```

```

add_block('built-in/Inport',[sys,/, 'Expendable6/exp pos out'])
set_param([sys,/, 'Expendable6/exp pos out'],...
          'Port','3',...
          'position',[120,180,140,200])

add_block('built-in/Mux',[sys,/, 'Expendable6/Mux 16'])
set_param([sys,/, 'Expendable6/Mux 16'],...
          'inputs','3',...
          'position',[350,201,385,239])
add_line([sys,/, 'Expendable6'],[575,70;910,70])
add_line([sys,/, 'Expendable6'],[745,120;745,80;910,80])
add_line([sys,/, 'Expendable6'],[745,165;770,165;770,85;910,85])
add_line([sys,/, 'Expendable6'],[750,685;785,685;785,650;855,650])
add_line([sys,/, 'Expendable6'],[755,590;770,590;770,630;855,630])
add_line([sys,/, 'Expendable6'],[985,640;995,640;995,415;1045,415])
add_line([sys,/, 'Expendable6'],[435,485;535,485])
add_line([sys,/, 'Expendable6'],[1175,425;1195,425])
add_line([sys,/, 'Expendable6'],[1090,425;1115,425])
add_line([sys,/, 'Expendable6'],[950,445;1045,445])
add_line([sys,/, 'Expendable6'],[885,640;890,640])
add_line([sys,/, 'Expendable6'],[715,640;855,640])
add_line([sys,/, 'Expendable6'],[600,445;697,445;697,585;720,585])
add_line([sys,/, 'Expendable6'],[600,445;697,445;697,595;720,595])
add_line([sys,/, 'Expendable6'],[565,490;647,490;647,645;680,645])
add_line([sys,/, 'Expendable6'],[565,490;647,490;647,635;680,635])
add_line([sys,/, 'Expendable6'],[525,535;612,535;612,680;715,680])
add_line([sys,/, 'Expendable6'],[525,535;612,535;612,690;715,690])
add_line([sys,/, 'Expendable6'],[325,485;385,485])
add_line([sys,/, 'Expendable6'],[785,430;1045,430])
add_line([sys,/, 'Expendable6'],[1065,680;1252,680;1252,605;1032,605;1032,460;1045,460])
add_line([sys,/, 'Expendable6'],[435,495;457,495;457,530;495,530])
add_line([sys,/, 'Expendable6'],[435,475;492,475;492,440;570,440])
add_line([sys,/, 'Expendable6'],[985,640;995,640;995,680;1015,680])
add_line([sys,/, 'Expendable6'],[285,150;505,150;505,450;570,450])
add_line([sys,/, 'Expendable6'],[285,170;477,170;477,495;535,495])
add_line([sys,/, 'Expendable6'],[285,190;447,190;447,540;495,540])
add_line([sys,/, 'Expendable6'],[670,90;717,90;717,75;910,75])
add_line([sys,/, 'Expendable6'],[610,70;610,400;1045,400])
add_line([sys,/, 'Expendable6'],[842,400;842,340;875,340])
add_line([sys,/, 'Expendable6'],[925,340;982,340;982,385;1045,385])
add_line([sys,/, 'Expendable6'],[955,85;1000,85])
add_line([sys,/, 'Expendable6'],[145,190;180,190])
add_line([sys,/, 'Expendable6'],[1245,415;1295,415])
add_line([sys,/, 'Expendable6'],[1245,430;1270,430;1270,460;1290,460])
add_line([sys,/, 'Expendable6'],[505,300;535,300])
add_line([sys,/, 'Expendable6'],[447,390;420,390])
add_line([sys,/, 'Expendable6'],[477,340;415,340])
add_line([sys,/, 'Expendable6'],[995,640;1090,640])
add_line([sys,/, 'Expendable6'],[410,100;445,100])
add_line([sys,/, 'Expendable6'],[285,150;305,150;305,75;365,75])
add_line([sys,/, 'Expendable6'],[285,160;310,160;310,85;365,85])
add_line([sys,/, 'Expendable6'],[320,170;320,95;365,95])
add_line([sys,/, 'Expendable6'],[285,180;325,180;325,105;365,105])
add_line([sys,/, 'Expendable6'],[330,190;330,115;365,115])
add_line([sys,/, 'Expendable6'],[835,305;885,305;885,95;910,95])

```

```

add_line([sys,/, 'Expendable6'],[285,210;345,210])
add_line([sys,/, 'Expendable6'],[285,220;345,220])
add_line([sys,/, 'Expendable6'],[285,230;345,230])
add_line([sys,/, 'Expendable6'],[390,220;560,220;560,165;695,165])
add_line([sys,/, 'Expendable6'],[770,225;780,225;780,180;875,180;875,90;910,90])
add_line([sys,/, 'Expendable6'],[285,200;335,200;335,125;365,125])
set_param([sys,/, 'Expendable6'],...
    'Mask Display','Missile   exppos in\npos (x,y,z)           \n           Exp X pos\n
Launch Flag      \n           Exp Y pos\nexp pos           \n out           Exp Z pos\n\nTime
PK\n            Stop flag\nEffective           \nradius  mexslanrange\n\nOperational           \nflag
Exp pos (x,y,z)')

```

```
% Finished composite block 'Expendable6'.
```

```
set_param([sys,/, 'Expendable6'],...
    'position',[1275,1126,1410,1304])
```

```
% Subsystem 'Expendable7'.
```

```
new_system([sys,/, 'Expendable7'])
set_param([sys,/, 'Expendable7'],'Location',[66,344,1080,839])
```

```
add_block('built-in/Inport',[sys,/, ['Expendable7/Missile position',13, '(x,y,z)']]
set_param([sys,/, ['Expendable7/Missile position',13, '(x,y,z)']],...
    'position',[300,475,320,495])
```

```
add_block('built-in/Inport',[sys,/, ['Expendable7/effective radius',13, 'of expendable']]
set_param([sys,/, ['Expendable7/effective radius',13, 'of expendable']],...
    'Port','5',...
    'position',[760,420,780,440])
```

```
add_block('built-in/Product',[sys,/, 'Expendable7/Product23'])
set_param([sys,/, 'Expendable7/Product23'],...
    'position',[720,675,745,695])
```

```
add_block('built-in/Product',[sys,/, 'Expendable7/Product25'])
set_param([sys,/, 'Expendable7/Product25'],...
    'position',[725,580,750,600])
```

```
add_block('built-in/Constant',[sys,/, 'Expendable7/Expendable type'])
set_param([sys,/, 'Expendable7/Expendable type'],...
    'Value','exp_type',...
    'position',[860,434,945,456])
```

```
add_block('built-in/Demux',[sys,/, 'Expendable7/Demux5'])
set_param([sys,/, 'Expendable7/Demux5'],...
    'outputs','3',...
    'position',[390,467,430,503])
```

```
add_block('built-in/Product',[sys,/, 'Expendable7/Product24'])
set_param([sys,/, 'Expendable7/Product24'],...
    'position',[685,630,710,650])
```

```

add_block('built-in/Sum',[sys,/, 'Expendable7/Sum18'])
set_param([sys,/, 'Expendable7/Sum18'],...
    'inputs','+++',...
    'position',[860,622,880,658])

add_block('built-in/Fcn',[sys,/, 'Expendable7/Fcn14'])
set_param([sys,/, 'Expendable7/Fcn14'],...
    'Expr','sqrt(u[1])',...
    'position',[895,629,980,651])

add_block('built-in/Sum',[sys,/, 'Expendable7/Sum16'])
set_param([sys,/, 'Expendable7/Sum16'],...
    'inputs','+',...
    'position',[540,480,560,500])

add_block('built-in/Sum',[sys,/, 'Expendable7/Sum15'])
set_param([sys,/, 'Expendable7/Sum15'],...
    'inputs','+',...
    'position',[575,435,595,455])

add_block('built-in/Sum',[sys,/, 'Expendable7/Sum17'])
set_param([sys,/, 'Expendable7/Sum17'],...
    'inputs','+',...
    'position',[500,525,520,545])

add_block('built-in/Memory',[sys,/, ['Expendable7/Memory',13,'IC: 0']])
set_param([sys,/, ['Expendable7/Memory',13,'IC: 0']],...
    'position',[1020,665,1060,695])

add_block('built-in/Mux',[sys,/, 'Expendable7/Mux11'])
set_param([sys,/, 'Expendable7/Mux11'],...
    'inputs','6',...
    'position',[1050,372,1085,473])

add_block('built-in/Memory',[sys,/, ['Expendable7/Memory1',13,'IC: 0']])
set_param([sys,/, ['Expendable7/Memory1',13,'IC: 0']],...
    'position',[880,325,920,355])

add_block('built-in/Demux',[sys,/, 'Expendable7/Demux4'])
set_param([sys,/, 'Expendable7/Demux4'],...
    'outputs','2',...
    'position',[1200,405,1240,440])

add_block('built-in/MATLAB Fcn',[sys,/, 'Expendable7/mexphit.m'])
set_param([sys,/, 'Expendable7/mexphit.m'],...
    'MATLAB Fcn','mexphit',...
    'Output Width','2',...
    'position',[1120,410,1170,440])

add_block('built-in/Demux',[sys,/, 'Expendable7/Demux3'])
set_param([sys,/, 'Expendable7/Demux3'],...
    'outputs','9')
set_param([sys,/, 'Expendable7/Demux3'],...
    'Mask Display',      xexp\n      xvexp\n      yexp\n      vyexp\nexp pos
zexp\n      vzept\n      x pos noise\n      y pos noise\n      z pos noise')

```



```

set_param([sys,'/','Expendable7/Demux3'],...
          'position',[185,138,280,242])

add_block('built-in/Inport',[sys,'/','Expendable7/operational',13,'flag',13,""])
set_param([sys,'/','Expendable7/operational',13,'flag',13,""],...
          'Port','6',...
          'position',[550,60,570,80])

add_block('built-in/Outport',[sys,'/','Expendable7/exp pos in1'])
set_param([sys,'/','Expendable7/exp pos in1'],...
          'Port','2',...
          'position',[540,290,560,310])

add_block('built-in/Outport',[sys,'/','Expendable7/exp pos in2'])
set_param([sys,'/','Expendable7/exp pos in2'],...
          'orientation',2,...
          'Port','3',...
          'position',[390,330,410,350])

add_block('built-in/Outport',[sys,'/','Expendable7/exp pos in3'])
set_param([sys,'/','Expendable7/exp pos in3'],...
          'orientation',2,...
          'Port','4',...
          'position',[395,380,415,400])

add_block('built-in/Outport',[sys,'/','Expendable7/STOP Flag'])
set_param([sys,'/','Expendable7/STOP Flag'],...
          'Port','6',...
          'position',[1295,450,1315,470])

add_block('built-in/Outport',[sys,'/','Expendable7/PK'])
set_param([sys,'/','Expendable7/PK'],...
          'Port','5',...
          'position',[1300,405,1320,425])

add_block('built-in/Outport',[sys,'/','Expendable7/mexslantrange'])
set_param([sys,'/','Expendable7/mexslantrange'],...
          'Port','7',...
          'position',[1095,630,1115,650])

add_block('built-in/Mux',[sys,'/','Expendable7/Mux15'])
set_param([sys,'/','Expendable7/Mux15'],...
          'inputs','6',...
          'position',[370,64,405,136])

add_block('built-in/Outport',[sys,'/','Expendable7/exp pos',13,'(x,vx,y,vy,z,vz)'])
set_param([sys,'/','Expendable7/exp pos',13,'(x,vx,y,vy,z,vz)'],...
          'Port','8',...
          'position',[450,90,470,110])

add_block('built-in/Constant',[sys,'/','Expendable7/Duration of wash noise'])
set_param([sys,'/','Expendable7/Duration of wash noise'],...
          'Value','washnoiseduration',...
          'position',[710,294,830,316])

```

```

add_block('built-in/Memory',[sys,'/','Expendable7/Memory2',13,'IC: [0 0 0]'])
set_param([sys,'/','Expendable7/Memory2',13,'IC: [0 0 0]'],...
    'x0','[0 0 0]',...
    'position',[700,150,740,180])

add_block('built-in/Inport',[sys,'/','Expendable7/time'])
set_param([sys,'/','Expendable7/time'],...
    'Port','4',...
    'position',[720,110,740,130])

add_block('built-in/Inport',[sys,'/','Expendable7/launch',13,'flag'])
set_param([sys,'/','Expendable7/launch',13,'flag'],...
    'Port','2',...
    'position',[645,80,665,100])

add_block('built-in/Mux',[sys,'/','Expendable7/Mux14'])
set_param([sys,'/','Expendable7/Mux14'],...
    'inputs','6',...
    'position',[915,64,950,101])

add_block('built-in/Outport',[sys,'/','Expendable7/exp pos in'])
set_param([sys,'/','Expendable7/exp pos in'],...
    'position',[1005,75,1025,95])

add_block('built-in/Constant',[sys,'/','Expendable7/standard dev of wash noise'])
set_param([sys,'/','Expendable7/standard dev of wash noise'],...
    'Value','washnoisestd',...
    'position',[685,215,765,235])

add_block('built-in/Inport',[sys,'/','Expendable7/exp pos out'])
set_param([sys,'/','Expendable7/exp pos out'],...
    'Port','3',...
    'position',[120,180,140,200])

add_block('built-in/Mux',[sys,'/','Expendable7/Mux16'])
set_param([sys,'/','Expendable7/Mux16'],...
    'inputs','3',...
    'position',[350,201,385,239])
add_line([sys,'/','Expendable7'],[575,70;910,70])
add_line([sys,'/','Expendable7'],[745,120;745,80;910,80])
add_line([sys,'/','Expendable7'],[745,165;770,165;770,85;910,85])
add_line([sys,'/','Expendable7'],[750,685;785,685;785,650;855,650])
add_line([sys,'/','Expendable7'],[755,590;770,590;770,630;855,630])
add_line([sys,'/','Expendable7'],[985,640;995,640;995,415;1045,415])
add_line([sys,'/','Expendable7'],[435,485;535,485])
add_line([sys,'/','Expendable7'],[1175,425;1195,425])
add_line([sys,'/','Expendable7'],[1090,425;1115,425])
add_line([sys,'/','Expendable7'],[950,445;1045,445])
add_line([sys,'/','Expendable7'],[885,640;890,640])
add_line([sys,'/','Expendable7'],[715,640;855,640])
add_line([sys,'/','Expendable7'],[600,445;697,445;697,585;720,585])
add_line([sys,'/','Expendable7'],[600,445;697,445;697,595;720,595])
add_line([sys,'/','Expendable7'],[565,490;647,490;647,645;680,645])
add_line([sys,'/','Expendable7'],[565,490;647,490;647,635;680,635])
add_line([sys,'/','Expendable7'],[525,535;612,535;612,680;715,680])

```

```

add_line([sys,'','Expendable7'],[525,535;612,535;612,690;715,690])
add_line([sys,'','Expendable7'],[325,485;385,485])
add_line([sys,'','Expendable7'],[785,430;1045,430])
add_line([sys,'','Expendable7'],[1065,680;1252,680;1252,605;1032,605;1032,460;1045,460])
add_line([sys,'','Expendable7'],[435,495;457,495;457,530;495,530])
add_line([sys,'','Expendable7'],[435,475;492,475;492,440;570,440])
add_line([sys,'','Expendable7'],[985,640;995,640;995,680;1015,680])
add_line([sys,'','Expendable7'],[285,150;505,150;505,450;570,450])
add_line([sys,'','Expendable7'],[285,170;477,170;477,495;535,495])
add_line([sys,'','Expendable7'],[285,190;447,190;447,540;495,540])
add_line([sys,'','Expendable7'],[670,90;717,90;717,75;910,75])
add_line([sys,'','Expendable7'],[610,70;610,400;1045,400])
add_line([sys,'','Expendable7'],[842,400;842,340;875,340])
add_line([sys,'','Expendable7'],[925,340;982,340;982,385;1045,385])
add_line([sys,'','Expendable7'],[955,85;1000,85])
add_line([sys,'','Expendable7'],[145,190;180,190])
add_line([sys,'','Expendable7'],[1245,415;1295,415])
add_line([sys,'','Expendable7'],[1245,430;1270,430;1270,460;1290,460])
add_line([sys,'','Expendable7'],[505,300;535,300])
add_line([sys,'','Expendable7'],[447,390;420,390])
add_line([sys,'','Expendable7'],[477,340;415,340])
add_line([sys,'','Expendable7'],[995,640;1090,640])
add_line([sys,'','Expendable7'],[410,100;445,100])
add_line([sys,'','Expendable7'],[285,150;305,150;305,75;365,75])
add_line([sys,'','Expendable7'],[285,160;310,160;310,85;365,85])
add_line([sys,'','Expendable7'],[320,170;320,95;365,95])
add_line([sys,'','Expendable7'],[285,180;325,180;325,105;365,105])
add_line([sys,'','Expendable7'],[330,190;330,115;365,115])
add_line([sys,'','Expendable7'],[835,305;885,305;885,95;910,95])
add_line([sys,'','Expendable7'],[285,210;345,210])
add_line([sys,'','Expendable7'],[285,220;345,220])
add_line([sys,'','Expendable7'],[285,230;345,230])
add_line([sys,'','Expendable7'],[390,220;560,220;560,165;695,165])
add_line([sys,'','Expendable7'],[770,225;780,225;780,180;875,180;875,90;910,90])
add_line([sys,'','Expendable7'],[285,200;335,200;335,125;365,125])
set_param([sys,'','Expendable7'],...
    'Mask Display','Missile   exppos in\npos (x,y,z)   \n           Exp X pos\n
Launch Flag      \n           Exp Y pos\nexp pos           \n out           Exp Z pos\n\nTime
PK\n            Stop flag\nEffective           \nradius  mexslanrange\n\nOperational   \nflag
Exp pos (x,y,z)')

```

```
% Finished composite block 'Expendable7'.
```

```
set_param([sys,'','Expendable7'],...
    'position',[1755,1056,1890,1234])
```

```
% Subsystem 'Expendable5'.
```

```
new_system([sys,'','Expendable5'])
set_param([sys,'','Expendable5'],'Location',[66,344,1080,839])
```

```
add_block('built-in/Inport',[sys,'','Expendable5/Missile position',13,'(x,y,z)'])
set_param([sys,'','Expendable5/Missile position',13,'(x,y,z)'],...
```

```

'position',[300,475,320,495])

add_block('built-in/Inport',[sys,/,['Expendable5/effective radius',13,'of expendable']])
set_param([sys,/,['Expendable5/effective radius',13,'of expendable']],...
'Port','5',...
'position',[760,420,780,440])

add_block('built-in/Product',[sys,/, 'Expendable5/Product23'])
set_param([sys,/, 'Expendable5/Product23'],...
'position',[720,675,745,695])

add_block('built-in/Product',[sys,/, 'Expendable5/Product25'])
set_param([sys,/, 'Expendable5/Product25'],...
'position',[725,580,750,600])

add_block('built-in/Constant',[sys,/, 'Expendable5/Expendable type'])
set_param([sys,/, 'Expendable5/Expendable type'],...
'Value','exp_type',...
'position',[860,434,945,456])

add_block('built-in/Demux',[sys,/, 'Expendable5/Demux5'])
set_param([sys,/, 'Expendable5/Demux5'],...
'outputs','3',...
'position',[390,467,430,503])

add_block('built-in/Product',[sys,/, 'Expendable5/Product24'])
set_param([sys,/, 'Expendable5/Product24'],...
'position',[685,630,710,650])

add_block('built-in/Sum',[sys,/, 'Expendable5/Sum18'])
set_param([sys,/, 'Expendable5/Sum18'],...
'inputs','+++',...
'position',[860,622,880,658])

add_block('built-in/Fcn',[sys,/, 'Expendable5/Fcn14'])
set_param([sys,/, 'Expendable5/Fcn14'],...
'Expr','sqrt(u[1])',...
'position',[895,629,980,651])

add_block('built-in/Sum',[sys,/, 'Expendable5/Sum16'])
set_param([sys,/, 'Expendable5/Sum16'],...
'inputs','+',...
'position',[540,480,560,500])

add_block('built-in/Sum',[sys,/, 'Expendable5/Sum15'])
set_param([sys,/, 'Expendable5/Sum15'],...
'inputs','+',...
'position',[575,435,595,455])

add_block('built-in/Sum',[sys,/, 'Expendable5/Sum17'])
set_param([sys,/, 'Expendable5/Sum17'],...
'inputs','+',...
'position',[500,525,520,545])

add_block('built-in/Memory',[sys,/, ['Expendable5/Memory',13,'IC: 0']])

```

```

set_param([sys, '/', ['Expendable5/Memory', 13, 'IC: 0']], ...
          'position', [1020, 665, 1060, 695])

add_block('built-in/Mux', [sys, '/', 'Expendable5/Mux11'])
set_param([sys, '/', 'Expendable5/Mux11'], ...
          'inputs', '6', ...
          'position', [1050, 372, 1085, 473])

add_block('built-in/Memory', [sys, '/', ['Expendable5/Memory1', 13, 'IC: 0']])
set_param([sys, '/', ['Expendable5/Memory1', 13, 'IC: 0']], ...
          'position', [880, 325, 920, 355])

add_block('built-in/Demux', [sys, '/', 'Expendable5/Demux4'])
set_param([sys, '/', 'Expendable5/Demux4'], ...
          'outputs', '2', ...
          'position', [1200, 405, 1240, 440])

add_block('built-in/MATLAB Fcn', [sys, '/', 'Expendable5/mexphit.m'])
set_param([sys, '/', 'Expendable5/mexphit.m'], ...
          'MATLAB Fcn', 'mexphit' ...
          'Output Width', '2', ...
          'position', [1120, 410, 1170, 440])

add_block('built-in/Demux', [sys, '/', 'Expendable5/Demux3'])
set_param([sys, '/', 'Expendable5/Demux3'], ...
          'outputs', '9')
set_param([sys, '/', 'Expendable5/Demux3'], ...
          'Mask Display',      xexp\n      xvexp\n      yexp\n      vyexp\nexp pos
zexp\n      vzexp\n x pos noise\n y pos noise\n z pos noise')
set_param([sys, '/', 'Expendable5/Demux3'], ...
          'position', [185, 138, 280, 242])

add_block('built-in/Inport', [sys, '/', ['Expendable5/operational', 13, 'flag', 13, '']])
set_param([sys, '/', ['Expendable5/operational', 13, 'flag', 13, '']], ...
          'Port', '6', ...
          'position', [550, 60, 570, 80])

add_block('built-in/Outport', [sys, '/', 'Expendable5/exp pos in1'])
set_param([sys, '/', 'Expendable5/exp pos in1'], ...
          'Port', '2', ...
          'position', [540, 290, 560, 310])

add_block('built-in/Outport', [sys, '/', 'Expendable5/exp pos in2'])
set_param([sys, '/', 'Expendable5/exp pos in2'], ...
          'orientation', '2', ...
          'Port', '3', ...
          'position', [390, 330, 410, 350])

add_block('built-in/Outport', [sys, '/', 'Expendable5/exp pos in3'])
set_param([sys, '/', 'Expendable5/exp pos in3'], ...
          'orientation', '2', ...
          'Port', '4', ...
          'position', [395, 380, 415, 400])

add_block('built-in/Outport', [sys, '/', 'Expendable5/STOP Flag'])

```

```

set_param([sys,'/','Expendable5/STOP Flag'],...
          'Port','6',...
          'position',[1295,450,1315,470])

add_block('built-in/Outport',[sys,'/','Expendable5/PK'])
set_param([sys,'/','Expendable5/PK'],...
          'Port','5',...
          'position',[1300,405,1320,425])

add_block('built-in/Outport',[sys,'/','Expendable5/mexslantrange'])
set_param([sys,'/','Expendable5/mexslantrange'],...
          'Port','7',...
          'position',[1095,630,1115,650])

add_block('built-in/Mux',[sys,'/','Expendable5/Mux 15'])
set_param([sys,'/','Expendable5/Mux 15'],...
          'inputs','6',...
          'position',[370,64,405,136])

add_block('built-in/Outport',[sys,'/','Expendable5/exp pos',13,'(x,vx,y,vy,z,vz)'])
set_param([sys,'/','Expendable5/exp pos',13,'(x,vx,y,vy,z,vz)'],...
          'Port','8',...
          'position',[450,90,470,110])

add_block('built-in/Constant',[sys,'/','Expendable5/Duration of wash noise'])
set_param([sys,'/','Expendable5/Duration of wash noise'],...
          'Value','washnoiseduration',...
          'position',[710,294,830,316])

add_block('built-in/Memory',[sys,'/','Expendable5/Memory2',13,'IC: [0 0 0]'])
set_param([sys,'/','Expendable5/Memory2',13,'IC: [0 0 0]'],...
          'x0','[0 0 0]',...
          'position',[700,150,740,180])

add_block('built-in/Inport',[sys,'/','Expendable5/time'])
set_param([sys,'/','Expendable5/time'],...
          'Port','4',...
          'position',[720,110,740,130])

add_block('built-in/Inport',[sys,'/','Expendable5/launch',13,'flag'])
set_param([sys,'/','Expendable5/launch',13,'flag'],...
          'Port','2',...
          'position',[645,80,665,100])

add_block('built-in/Mux',[sys,'/','Expendable5/Mux 14'])
set_param([sys,'/','Expendable5/Mux 14'],...
          'inputs','6',...
          'position',[915,64,950,101])

add_block('built-in/Outport',[sys,'/','Expendable5/exp pos in'])
set_param([sys,'/','Expendable5/exp pos in'],...
          'position',[1005,75,1025,95])

add_block('built-in/Constant',[sys,'/','Expendable5/standard dev of wash noise'])
set_param([sys,'/','Expendable5/standard dev of wash noise'],...

```

```

'Value','washnoisestd',...
'position',[685,215,765,235])

add_block('built-in/Inport',[sys,/, 'Expendable5/exp pos out'])
set_param([sys,/, 'Expendable5/exp pos out'],...
'Port','3',...
'position',[120,180,140,200])

add_block('built-in/Mux',[sys,/, 'Expendable5/Mux 16'])
set_param([sys,/, 'Expendable5/Mux 16'],...
'inputs','3',...
'position',[350,201,385,239])
add_line([sys,/, 'Expendable5'],[575,70;910,70])
add_line([sys,/, 'Expendable5'],[745,120;745,80;910,80])
add_line([sys,/, 'Expendable5'],[745,165;770,165;770,85;910,85])
add_line([sys,/, 'Expendable5'],[750,685;785,685;785,650;855,650])
add_line([sys,/, 'Expendable5'],[755,590;770,590;770,630;855,630])
add_line([sys,/, 'Expendable5'],[985,640;995,640;995,415;1045,415])
add_line([sys,/, 'Expendable5'],[435,485;535,485])
add_line([sys,/, 'Expendable5'],[1175,425;1195,425])
add_line([sys,/, 'Expendable5'],[1090,425;1115,425])
add_line([sys,/, 'Expendable5'],[950,445;1045,445])
add_line([sys,/, 'Expendable5'],[885,640;890,640])
add_line([sys,/, 'Expendable5'],[715,640;855,640])
add_line([sys,/, 'Expendable5'],[600,445;697,445;697,585;720,585])
add_line([sys,/, 'Expendable5'],[600,445;697,445;697,595;720,595])
add_line([sys,/, 'Expendable5'],[565,490;647,490;647,645;680,645])
add_line([sys,/, 'Expendable5'],[565,490;647,490;647,635;680,635])
add_line([sys,/, 'Expendable5'],[525,535;612,535;612,680;715,680])
add_line([sys,/, 'Expendable5'],[525,535;612,535;612,690;715,690])
add_line([sys,/, 'Expendable5'],[325,485;385,485])
add_line([sys,/, 'Expendable5'],[785,430;1045,430])
add_line([sys,/, 'Expendable5'],[1065,680;1252,680;1252,605;1032,605;1032,460;1045,460])
add_line([sys,/, 'Expendable5'],[435,495;457,495;457,530;495,530])
add_line([sys,/, 'Expendable5'],[435,475;492,475;492,440;570,440])
add_line([sys,/, 'Expendable5'],[985,640;995,640;995,680;1015,680])
add_line([sys,/, 'Expendable5'],[285,150;505,150;505,450;570,450])
add_line([sys,/, 'Expendable5'],[285,170;477,170;477,495;535,495])
add_line([sys,/, 'Expendable5'],[285,190;447,190;447,540;495,540])
add_line([sys,/, 'Expendable5'],[670,90;717,90;717,75;910,75])
add_line([sys,/, 'Expendable5'],[610,70;610,400;1045,400])
add_line([sys,/, 'Expendable5'],[842,400;842,340;875,340])
add_line([sys,/, 'Expendable5'],[925,340;982,340;982,385;1045,385])
add_line([sys,/, 'Expendable5'],[955,85;1000,85])
add_line([sys,/, 'Expendable5'],[145,190;180,190])
add_line([sys,/, 'Expendable5'],[1245,415;1295,415])
add_line([sys,/, 'Expendable5'],[1245,430;1270,430;1270,460;1290,460])
add_line([sys,/, 'Expendable5'],[505,300;535,300])
add_line([sys,/, 'Expendable5'],[447,390;420,390])
add_line([sys,/, 'Expendable5'],[477,340;415,340])
add_line([sys,/, 'Expendable5'],[995,640;1090,640])
add_line([sys,/, 'Expendable5'],[410,100;445,100])
add_line([sys,/, 'Expendable5'],[285,150;305,150;305,75;365,75])
add_line([sys,/, 'Expendable5'],[285,160;310,160;310,85;365,85])
add_line([sys,/, 'Expendable5'],[320,170;320,95;365,95])

```

```

add_line([sys,/, 'Expendable5'],[285,180;325,180;325,105;365,105])
add_line([sys,/, 'Expendable5'],[330,190;330,115;365,115])
add_line([sys,/, 'Expendable5'],[835,305;885,305;885,95;910,95])
add_line([sys,/, 'Expendable5'],[285,210;345,210])
add_line([sys,/, 'Expendable5'],[285,220;345,220])
add_line([sys,/, 'Expendable5'],[285,230;345,230])
add_line([sys,/, 'Expendable5'],[390,220;560,220;560,165;695,165])
add_line([sys,/, 'Expendable5'],[770,225;780,225;780,180;875,180;875,90;910,90])
add_line([sys,/, 'Expendable5'],[285,200;335,200;335,125;365,125])
set_param([sys,/, 'Expendable5'],...
'Mask Display',Missile   exppos in\npos (x,y,z)           \n           Exp X pos\n
Launch Flag           \n           Exp Y pos\nexp pos           \n out           Exp Z pos\n\nTime
PK\n                 Stop flag\nEffective                 \nradius   mexslanrange\n\nOperational           \nflag
Exp pos (x,y,z)')

```

```
% Finished composite block 'Expendable5'.
```

```
set_param([sys,/, 'Expendable5'],...
'position',[730,1051,865,1229])
```

```
% Subsystem 'Expendable4'.
```

```
new_system([sys,/, 'Expendable4'])
set_param([sys,/, 'Expendable4'], 'Location',[66,344,1080,839])
```

```
add_block('built-in/Inport',[sys,/, ['Expendable4/Missile position',13,'(x,y,z)']]
set_param([sys,/, ['Expendable4/Missile position',13,'(x,y,z)']],...
'position',[300,475,320,495])
```

```
add_block('built-in/Inport',[sys,/, ['Expendable4/effective radius',13,'of expendable']]
set_param([sys,/, ['Expendable4/effective radius',13,'of expendable']],...
'Port','S',...
'position',[760,420,780,440])
```

```
add_block('built-in/Product',[sys,/, 'Expendable4/Product23'])
set_param([sys,/, 'Expendable4/Product23'],...
'position',[720,675,745,695])
```

```
add_block('built-in/Product',[sys,/, 'Expendable4/Product25'])
set_param([sys,/, 'Expendable4/Product25'],...
'position',[725,580,750,600])
```

```
add_block('built-in/Constant',[sys,/, 'Expendable4/Expendable type'])
set_param([sys,/, 'Expendable4/Expendable type'],...
'Value','exp_type',...
'position',[860,434,945,456])
```

```
add_block('built-in/Demux',[sys,/, 'Expendable4/Demux5'])
set_param([sys,/, 'Expendable4/Demux5'],...
'outputs','3',...
'position',[390,467,430,503])
```

```
add_block('built-in/Product',[sys,/, 'Expendable4/Product24'])
```



```

set_param([sys, '/', 'Expendable4/Product24'],...
          'position',[685,630,710,650])

add_block('built-in/Sum',[sys, '/', 'Expendable4/Sum18'])
set_param([sys, '/', 'Expendable4/Sum18'],...
          'inputs','+++',...
          'position',[860,622,880,658])

add_block('built-in/Fcn',[sys, '/', 'Expendable4/Fcn14'])
set_param([sys, '/', 'Expendable4/Fcn14'],...
          'Expr','sqrt(u[1])',...
          'position',[895,629,980,651])

add_block('built-in/Sum',[sys, '/', 'Expendable4/Sum16'])
set_param([sys, '/', 'Expendable4/Sum16'],...
          'inputs','+',...
          'position',[540,480,560,500])

add_block('built-in/Sum',[sys, '/', 'Expendable4/Sum15'])
set_param([sys, '/', 'Expendable4/Sum15'],...
          'inputs','+',...
          'position',[575,435,595,455])

add_block('built-in/Sum',[sys, '/', 'Expendable4/Sum17'])
set_param([sys, '/', 'Expendable4/Sum17'],...
          'inputs','+',...
          'position',[500,525,520,545])

add_block('built-in/Memory',[sys, '/', ['Expendable4/Memory',13,'IC: 0']])
set_param([sys, '/', ['Expendable4/Memory',13,'IC: 0']],...
          'position',[1020,665,1060,695])

add_block('built-in/Mux',[sys, '/', 'Expendable4/Mux11'])
set_param([sys, '/', 'Expendable4/Mux11'],...
          'inputs','6',...
          'position',[1050,372,1085,473])

add_block('built-in/Memory',[sys, '/', ['Expendable4/Memory1',13,'IC: 0']])
set_param([sys, '/', ['Expendable4/Memory1',13,'IC: 0']],...
          'position',[880,325,920,355])

add_block('built-in/Demux',[sys, '/', 'Expendable4/Demux4'])
set_param([sys, '/', 'Expendable4/Demux4'],...
          'outputs','2',...
          'position',[1200,405,1240,440])

add_block('built-in/MATLAB Fcn',[sys, '/', 'Expendable4/mexphit.m'])
set_param([sys, '/', 'Expendable4/mexphit.m'],...
          'MATLAB Fcn','mexphit',...
          'Output Width','2',...
          'position',[1120,410,1170,440])

add_block('built-in/Demux',[sys, '/', 'Expendable4/Demux3'])
set_param([sys, '/', 'Expendable4/Demux3'],...
          'outputs','9')

```

```

set_param([sys,'/','Expendable4/Demux3'],...
          'Mask Display',          xexp\n      xvexp\n      yexp\n      vyexp\nexp pos
zexp\n      vze\n      x pos noise\n      y pos noise\n      z pos noise')
set_param([sys,'/','Expendable4/Demux3'],...
          'position',[185,138,280,242])

add_block('built-in/Inport',[sys,'/','Expendable4/operational',13,'flag',13,""])
set_param([sys,'/','Expendable4/operational',13,'flag',13,""],...
          'Port','6',...
          'position',[550,60,570,80])

add_block('built-in/Outport',[sys,'/','Expendable4/exp pos in1'])
set_param([sys,'/','Expendable4/exp pos in1'],...
          'Port','2',...
          'position',[540,290,560,310])

add_block('built-in/Outport',[sys,'/','Expendable4/exp pos in2'])
set_param([sys,'/','Expendable4/exp pos in2'],...
          'orientation',2,...
          'Port','3',...
          'position',[390,330,410,350])

add_block('built-in/Outport',[sys,'/','Expendable4/exp pos in3'])
set_param([sys,'/','Expendable4/exp pos in3'],...
          'orientation',2,...
          'Port','4',...
          'position',[395,380,415,400])

add_block('built-in/Outport',[sys,'/','Expendable4/STOP Flag'])
set_param([sys,'/','Expendable4/STOP Flag'],...
          'Port','6',...
          'position',[1295,450,1315,470])

add_block('built-in/Outport',[sys,'/','Expendable4/PK'])
set_param([sys,'/','Expendable4/PK'],...
          'Port','5',...
          'position',[1300,405,1320,425])

add_block('built-in/Outport',[sys,'/','Expendable4/mexslanrange'])
set_param([sys,'/','Expendable4/mexslanrange'],...
          'Port','7',...
          'position',[1095,630,1115,650])

add_block('built-in/Mux',[sys,'/','Expendable4/Mux15'])
set_param([sys,'/','Expendable4/Mux15'],...
          'inputs','6',...
          'position',[370,64,405,136])

add_block('built-in/Outport',[sys,'/','Expendable4/exp pos',13,'(x,vx,y,vy,z,vz)'])
set_param([sys,'/','Expendable4/exp pos',13,'(x,vx,y,vy,z,vz)'],...
          'Port','8',...
          'position',[450,90,470,110])

add_block('built-in/Constant',[sys,'/','Expendable4/Duration of wash noise'])
set_param([sys,'/','Expendable4/Duration of wash noise'],...

```

```

'Value','washnoiseduration',...
'position',[710,294,830,316])

add_block('built-in/Memory',[sys,/,['Expendable4/Memory2',13,'IC: [0 0 0]']])
set_param([sys,/,['Expendable4/Memory2',13,'IC: [0 0 0]']],...
'x0',[0 0 0],...
'position',[700,150,740,180])

add_block('built-in/Inport',[sys,/, 'Expendable4/time'])
set_param([sys,/, 'Expendable4/time'],...
'Port','4',...
'position',[720,110,740,130])

add_block('built-in/Inport',[sys,/,['Expendable4/launch',13,'flag']])
set_param([sys,/,['Expendable4/launch',13,'flag']],...
'Port','2',...
'position',[645,80,665,100])

add_block('built-in/Mux',[sys,/, 'Expendable4/Mux 14'])
set_param([sys,/, 'Expendable4/Mux 14'],...
'inputs','6',...
'position',[915,64,950,101])

add_block('built-in/Outport',[sys,/, 'Expendable4/exp pos in'])
set_param([sys,/, 'Expendable4/exp pos in'],...
'position',[1005,75,1025,95])

add_block('built-in/Constant',[sys,/, 'Expendable4/standard dev of wash noise'])
set_param([sys,/, 'Expendable4/standard dev of wash noise'],...
'Value','washnoisedstd',...
'position',[685,215,765,235])

add_block('built-in/Inport',[sys,/, 'Expendable4/exp pos out'])
set_param([sys,/, 'Expendable4/exp pos out'],...
'Port','3',...
'position',[120,180,140,200])

add_block('built-in/Mux',[sys,/, 'Expendable4/Mux 16'])
set_param([sys,/, 'Expendable4/Mux 16'],...
'inputs','3',...
'position',[350,201,385,239])
add_line([sys,/, 'Expendable4'],[575,70;910,70])
add_line([sys,/, 'Expendable4'],[745,120;745,80;910,80])
add_line([sys,/, 'Expendable4'],[745,165;770,165;770,85;910,85])
add_line([sys,/, 'Expendable4'],[750,685;785,685;785,650;855,650])
add_line([sys,/, 'Expendable4'],[755,590;770,590;770,630;855,630])
add_line([sys,/, 'Expendable4'],[985,640;995,640;995,415;1045,415])
add_line([sys,/, 'Expendable4'],[435,485;535,485])
add_line([sys,/, 'Expendable4'],[1175,425;1195,425])
add_line([sys,/, 'Expendable4'],[1090,425;1115,425])
add_line([sys,/, 'Expendable4'],[950,445;1045,445])
add_line([sys,/, 'Expendable4'],[885,640;890,640])
add_line([sys,/, 'Expendable4'],[715,640;855,640])
add_line([sys,/, 'Expendable4'],[600,445;697,445;697,585;720,585])
add_line([sys,/, 'Expendable4'],[600,445;697,445;697,595;720,595])

```

```

add_line([sys,/, 'Expendable4'],[565,490;647,490;647,645;680,645])
add_line([sys,/, 'Expendable4'],[565,490;647,490;647,635;680,635])
add_line([sys,/, 'Expendable4'],[525,535;612,535;612,680;715,680])
add_line([sys,/, 'Expendable4'],[525,535;612,535;612,690;715,690])
add_line([sys,/, 'Expendable4'],[325,485;385,485])
add_line([sys,/, 'Expendable4'],[785,430;1045,430])
add_line([sys,/, 'Expendable4'],[1065,680;1252,680;1252,605;1032,605;1032,460;1045,460])
add_line([sys,/, 'Expendable4'],[435,495;457,495;457,530;495,530])
add_line([sys,/, 'Expendable4'],[435,475;492,475;492,440;570,440])
add_line([sys,/, 'Expendable4'],[985,640;995,640;995,680;1015,680])
add_line([sys,/, 'Expendable4'],[285,150;505,150;505,450;570,450])
add_line([sys,/, 'Expendable4'],[285,170;477,170;477,495;535,495])
add_line([sys,/, 'Expendable4'],[285,190;447,190;447,540;495,540])
add_line([sys,/, 'Expendable4'],[670,90;717,90;717,75;910,75])
add_line([sys,/, 'Expendable4'],[610,70;610,400;1045,400])
add_line([sys,/, 'Expendable4'],[842,400;842,340;875,340])
add_line([sys,/, 'Expendable4'],[925,340;982,340;982,385;1045,385])
add_line([sys,/, 'Expendable4'],[955,85;1000,85])
add_line([sys,/, 'Expendable4'],[145,190;180,190])
add_line([sys,/, 'Expendable4'],[1245,415;1295,415])
add_line([sys,/, 'Expendable4'],[1245,430;1270,430;1270,460;1290,460])
add_line([sys,/, 'Expendable4'],[505,300;535,300])
add_line([sys,/, 'Expendable4'],[447,390;420,390])
add_line([sys,/, 'Expendable4'],[477,340;415,340])
add_line([sys,/, 'Expendable4'],[995,640;1090,640])
add_line([sys,/, 'Expendable4'],[410,100;445,100])
add_line([sys,/, 'Expendable4'],[285,150;305,150;305,75;365,75])
add_line([sys,/, 'Expendable4'],[285,160;310,160;310,85;365,85])
add_line([sys,/, 'Expendable4'],[320,170;320,95;365,95])
add_line([sys,/, 'Expendable4'],[285,180;325,180;325,105;365,105])
add_line([sys,/, 'Expendable4'],[330,190;330,115;365,115])
add_line([sys,/, 'Expendable4'],[835,305;885,305;885,95;910,95])
add_line([sys,/, 'Expendable4'],[285,210;345,210])
add_line([sys,/, 'Expendable4'],[285,220;345,220])
add_line([sys,/, 'Expendable4'],[285,230;345,230])
add_line([sys,/, 'Expendable4'],[390,220;560,220;560,165;695,165])
add_line([sys,/, 'Expendable4'],[770,225;780,225;780,180;875,180;875,90;910,90])
add_line([sys,/, 'Expendable4'],[285,200;335,200;335,125;365,125])
set_param([sys,/, 'Expendable4'],...
    'Mask Display', 'Missile   expos in\nnpos (x,y,z)           \n           Exp X pos\n
Launch Flag           \n           Exp Y pos\nexp pos           \n out           Exp Z pos\n\nTime
PK\n                 Stop flag\nEffective           \nradius   mexslanrange\n\nOperational           \nflag
Exp pos (x,y,z)')

```

% Finished composite block 'Expendable4'.

```

set_param([sys,/, 'Expendable4'],...
    'position',[230,1021,365,1199])
add_line(sys,[1265,720;1295,720;1295,920;1310,920])
add_line(sys,[1075,860;1110,860])
add_line(sys,[355,500;320,500;320,310;370,310])
add_line(sys,[530,335;570,335;570,185;610,185])
add_line(sys,[80,515;145,515])
add_line(sys,[790,635;885,635;885,665;920,665])

```

```

add_line(sys,[790,635;841,635;841,825;875,825])
add_line(sys,[795,320;865,320;865,695;920,695])
add_line(sys,[280,295;370,295])
add_line(sys,[530,305;540,305;540,170;610,170])
add_line(sys,[80,515;110,515;110,285;140,285])
add_line(sys,[790,615;820,615;820,850;875,850])
add_line(sys,[790,655;805,655;805,725;920,725])
add_line(sys,[280,295;295,295;295,158;530,158;530,120;850,120])
add_line(sys,[841,635;841,633;840,633;840,565;940,565])
add_line(sys,[110,338;110,340;370,340])
add_line(sys,[295,293;295,650;615,650])
add_line(sys,[530,153;530,155;610,155])
add_line(sys,[770,170;795,170;795,233;350,233;350,325;370,325])
add_line(sys,[280,270;630,270;630,305;650,305])
add_line(sys,[600,233;600,500;500,500])
add_line(sys,[600,500;600,553;600,620;615,620])
add_line(sys,[795,170;795,145;850,145])
add_line(sys,[1055,695;1065,695;1065,780;1110,780])
add_line(sys,[550,650;550,800;1110,800])
add_line(sys,[985,840;1110,840])
add_line(sys,[1040,585;1075,585;1075,740;1110,740])
add_line(sys,[1040,540;1085,540;1085,720;1110,720])
add_line(sys,[80,515;125,515;125,760;1110,760])
add_line(sys,[680,1185;725,1185])
add_line(sys,[1265,740;1305,740;1305,115;1475,115])
add_line(sys,[1265,760;1315,760;1315,370;1505,370])
add_line(sys,[2075,450;2085,450;2085,1005;1180,995])
add_line(sys,[1220,965;1220,945;1310,945])
add_line(sys,[1265,820;1275,820;1275,910;680,910;680,1095;725,1095])
add_line(sys,[1500,900;1510,900;1510,835;1335,835;1335,500;1465,500;1465,490;1505,490])
add_line(sys,[1500,890;1500,840;1325,840;1325,245;1455,245;1455,235;1475,235])
add_line(sys,[1500,940;1500,1010;1230,1010;1230,1290;1270,1290])
add_line(sys,[630,270;1100,270;1110,820])
add_line(sys,[780,760;780,895;1310,895])
add_line(sys,[1090,760;1090,685;1555,685])
add_line(sys,[1285,685;1285,430;1505,430])
add_line(sys,[1285,450;1285,175;1475,175])
add_line(sys,[645,760;645,1155;725,1155])
add_line(sys,[125,760;125,1125;225,1125])
add_line(sys,[1095,895;1095,1230;1270,1230])
add_line(sys,[1095,1155;1095,1105;1710,1105;1710,1160;1750,1160])
add_line(sys,[795,225;1125,225;1125,85;1475,85])
add_line(sys,[1125,225;1125,340;1505,340])
add_line(sys,[1125,340;1125,595;1555,595])
add_line(sys,[600,330;600,335;650,335])
add_line(sys,[600,620;205,620;205,1015;1050,1015;1050,1140;1270,1140])
add_line(sys,[1050,1075;1050,1045;1740,1045;1750,1070])
add_line(sys,[1440,920;1450,920])
add_line(sys,[270,960;190,960;190,1095;225,1095])
add_line(sys,[370,1040;370,960;330,960])
add_line(sys,[370,1180;370,1373;1200,1373;1200,995])
add_line(sys,[370,1060;385,1060;385,1030;450,1030])
add_line(sys,[370,1080;395,1080;405,1060])
add_line(sys,[370,1100;465,1100;465,1085;485,1085])
add_line(sys,[370,1160;395,1160])

```

add_line(sys,[370,1120;415,1120])
add_line(sys,[370,1140;500,1140])
add_line(sys,[600,620;205,620;205,1035;225,1035])
add_line(sys,[1265,800;1285,800;1285,925;60,925;60,1065;225,1065])
add_line(sys,[180,1155;225,1155])
add_line(sys,[1500,920;1570,920;1570,1385;215,1385;225,1185])
add_line(sys,[770,980;690,980;690,1125;725,1125])
add_line(sys,[870,1070;870,980;830,980])
add_line(sys,[715,1015;725,1065])
add_line(sys,[870,1210;870,1330;1220,1330;1220,995])
add_line(sys,[870,1090;885,1090;885,1055;980,1055])
add_line(sys,[870,1110;900,1110;900,1075;920,1075])
add_line(sys,[1500,930;1515,930;1515,1035;695,1035;695,1215;725,1215])
add_line(sys,[870,1130;965,1130;975,1105])
add_line(sys,[870,1150;940,1150])
add_line(sys,[870,1190;890,1190])
add_line(sys,[870,1170;1015,1170])
add_line(sys,[1315,1075;1255,1075;1255,1200;1270,1200])
add_line(sys,[1415,1145;1415,1075;1375,1075])
add_line(sys,[1415,1285;1415,1335;1240,1335;1240,995])
add_line(sys,[1195,1260;1270,1260])
add_line(sys,[1265,840;1280,840;1280,1115;1260,1115;1270,1170])
add_line(sys,[1415,1165;1430,1165;1430,1125;1510,1125])
add_line(sys,[1415,1185;1440,1185;1440,1145;1460,1145])
add_line(sys,[1415,1205;1445,1205;1445,1185;1510,1185])
add_line(sys,[1415,1225;1455,1225])
add_line(sys,[1415,1265;1455,1265])
add_line(sys,[1415,1245;1585,1245])
add_line(sys,[1795,975;1735,975;1735,1130;1750,1130])
add_line(sys,[1895,1075;1895,975;1855,975])
add_line(sys,[1895,1215;1905,1215;1905,1240;2190,1240;2190,1030;1260,1030;1260,995])
add_line(sys,[1895,1095;1910,1095;1910,1065;2010,1065])
add_line(sys,[1895,1115;1925,1115;1925,1090;1955,1090])
add_line(sys,[1895,1135;2020,1135;2020,1105;2040,1105])
add_line(sys,[1895,1195;1915,1195])
add_line(sys,[1895,1155;1905,1155])
add_line(sys,[1895,1175;2045,1175])
add_line(sys,[1500,950;1700,950;1700,1220;1750,1220])
add_line(sys,[1690,1190;1750,1190])
add_line(sys,[1265,860;1720,860;1720,1100;1750,1100])
add_line(sys,[1600,545;1540,545;1540,655;1555,655])
add_line(sys,[1700,600;1715,600;1715,545;1660,545])
add_line(sys,[1530,285;1470,285;1470,400;1505,400])
add_line(sys,[1650,345;1660,345;1660,285;1590,285])
add_line(sys,[1525,30;1465,30;1475,145])
add_line(sys,[1620,90;1625,90;1625,30;1585,30])
add_line(sys,[1620,110;1645,110;1645,80;1745,80])
add_line(sys,[1620,130;1650,130;1650,100;1690,100])
add_line(sys,[1620,150;1660,150;1660,130;1750,130])
add_line(sys,[1620,210;1645,210])
add_line(sys,[1620,190;1775,190])
add_line(sys,[1620,170;1665,170;1665,160;1690,160])
add_line(sys,[1620,230;1640,230;1640,250;1905,250;1905,440;2035,440])
add_line(sys,[1650,365;1665,365;1665,340;1740,340])
add_line(sys,[1650,385;1680,385;1690,365])

```

add_line(sys,[1650,405;1755,405;1755,380;1775,380])
add_line(sys,[1650,425;1700,425;1700,420;1775,420])
add_line(sys,[1650,465;1705,465])
add_line(sys,[1650,445;1835,445])
add_line(sys,[1650,485;1665,485;1665,505;1950,505;1950,450;2035,450])
add_line(sys,[1700,620;1740,620;1740,585;1815,585])
add_line(sys,[1700,640;1745,640;1755,605])
add_line(sys,[1700,660;1760,660;1760,635;1830,635])
add_line(sys,[1700,680;1715,680;1715,670;1780,670])
add_line(sys,[1700,700;1865,700])
add_line(sys,[1700,720;1730,720])
add_line(sys,[1700,740;1720,740;1720,770;2015,770;2015,460;2035,460])
add_line(sys,[1265,780;1360,780;1360,625;1555,625])
add_line(sys,[1475,715;1555,715])
add_line(sys,[1450,460;1505,460])
add_line(sys,[1445,205;1475,205])
add_line(sys,[1500,910;1520,910;1520,745;1555,745])

```

drawnow

```

% Return any arguments.
if (nargin != nargout)
    % Must use feval here to access system in memory
    if (nargin > 3)
        if (flag == 0)
            eval(['ret,x0,str,ts,xts']='sys,'(t,x,u,flag);')
        else
            eval(['ret =' , sys,'(t,x,u,flag);'])
        end
    else
        [ret,x0,str,ts,xts] = feval(sys);
    end
else
    drawnow % Flash up the model and execute load callback
end

```

```

function r=Inchtram(u)
%*****
% launchtram.m
% Used in BLOCK:Launch_multiple
%
% Authors: Capt. Joel Hagan & Capt Brian Peterson, USAF
%         GSE-95D Air Force Institute of Technology
% Language: Matlab
% Project: AKKCT (Aircraft Kintetic Kill Countermeasures Technology)
% Last Updated: 14 SEP 95
%
% Function: This function calculates the trajectory and velocity of the
%           expendable when it is launched and is still in the launch canister.
%           Once the global time reaches
%           the launch time, the position and velocity of the aircraft
%           are used to calculate the trajectory for the expendable using the
%           expendable characteristics. This is done using ODE23 in the simulation
%           so again. a global variable (onceit!) is used to prevent the calculation
%           from happening twice. The results are stored in global variables
%           expvx(1-7),expvy(1-7),expvz(1-7). No noise is entered into the
%           expendable trajectory in this function. A flag is set for each
%           expendable from -1 to 1 when the expendable is launched.
%
%*****

```

```

%u1=time;
%u2=distance check between missile and AC
%u3=xac
%u4=yac
%u5=zac
%u6=xvac
%u7=yvac
%u8=Phi_Angle
%u9=Theta_Angle
%u10=time_to_target
%u11=acmtheta
%u12=acmphi
%u13=Quadrant launch
%u14=tracker
%u15=Tduration
%u16=R_Thrust
%u17=lethaldist
%u18=muzzle_vel
%u19-25=operational times feedback

%u26-32=flags feedback
%u33=launchtime feedback
%u34=detecttime
%u35=delay between expendables
%u36=launch delays (computation and slew)

%r1-r7=oper_time

%r8-14=flag

```



```

%r15=launchtime;
global expvx1 expvy1 expvz1
global expvx2 expvy2 expvz2
global expvx3 expvy3 expvz3
global expvx4 expvy4 expvz4
global expvx5 expvy5 expvz5
global expvx6 expvy6 expvz6
global expvx7 expvy7 expvz7
global onceitl lnchtimem

xacl=u(3);
yacl=u(4);
zACL=u(5);
zvacl=u(6);
xvacl=u(7);
Phi_Angle=u(8)/57.3;
Theta_Angle=u(9)/57.3;
time_to_target=u(10);
thetamissile_at_launch=u(11);
phimissile_at_launch=u(12);
quadlaunch=u(13);
tracker=u(14);
Tduration=u(15);
R_Thrust=u(16);
lethaldist=u(17);
muzzle_vel=u(18);
detect_time=u(34);
expdelay=u(35);
oldlaunch=u(33);
delays=u(36);

launch_time=.001*round(u(1)/.001);
quadlaunch=.001*round(u(13)/.001);
r(15)=oldlaunch;

for number=1:7,

r(number)=u(18+number);
r(7+number)=u(25+number);

if (u(25+number)==-1) & (launch_time>=(detect_time+delays)) &...
(((tracker==1)&(((u(2)==0)&(r(8)==-1))|(launch_time>=(oldlaunch+((number-1)*expdelay))))|...
((tracker==0)&(launch_time>=quadlaunch+((number-1)*expdelay)))) & (onceitl(number)==1)
r(7+number)=1;
if u(26)==-1
r(15)=launch_time;
end;
lnchtimem(number)=launch_time;
if tracker==1 %Add time required for expendable to get from launcher to target to the global
%time at which launch occurs in order to get time at which expendable is operational
opertime=time_to_target+launch_time;
else % only have quadrant detection
if (thetamissile_at_launch>=0) & (thetamissile_at_launch<(90/57.3))
opertime=launch_time+.1444;

```

```

else
    opertime=launch_time+.1443;
end;
end;
r(number)=round(opertime/.001)*.001;
end;

if (u(25+number)==-1) & (launch_time>=(detect_time+delays)) &...
(((tracker==1)&((((u(2)==0)&(r(8)==-1))|(launch_time>=(oldlaunch+((number-1)*expdelay))))))|...
((tracker==0)&(launch_time>=quadlaunch+((number-1)*expdelay))) & (onceitl(number)==0)

r(7+number)=1;
if u(26)==-1
    r(15)=launch_time;
end;

onceitl(number)=1;
launch_time
number

%Calculate Launch Angle if there is a tracker on-board the A/C
    if tracker==1

        %Add time required for expendable to get from launcher to target to the global
        %time at which launch occurs in order to get time at which expendable is operational

        opertime=time_to_target+launch_time;

        %Calculate coordinates in space you wish to hit

        x_wish_hit=xacl+lenthaldist*sin(phimissile_at_launch)*cos(thetamissile_at_launch);
        y_wish_hit=yacl+lenthaldist*sin(phimissile_at_launch)*sin(thetamissile_at_launch);
        z_wish_hit=zacl+lenthaldist*cos(phimissile_at_launch);
    else
        % only have quadrant detection
        if (thetamissile_at_launch>=0) & (thetamissile_at_launch<(90/57.3))
            Phi_Angle=(93.12/57.3);
            Theta_Angle=(12/57.3);
            opertime=launch_time+.1456;
        else
            Phi_Angle=(93.12/57.3);
            Theta_Angle=(135/57.3);
            opertime=launch_time+.1456;
        end
    end

end

%Determine A/C position at which expendable detection occurs

launchx=xacl;
launchy=yacl ;
launchz=zacl;

```

```
%Determine A/C velocity at which expendable launch occurs
```

```
launchvx=xvacl;  
launchvz=zvacl;
```

```
%Determine position and velocity of expendable from time of  
%launch to some future time. Said future time should be  
%after the expected time of missile intercept by expendable  
%or missile intercept of aircraft.
```

```
%Determine X position of expendable  
%Expendable under thrust  
if Tduration~=0 & R_Thrust~=0;
```

```
[txyzT,pvxyzT]=ode23('dqxyzt',launch_time-.001,launch_time-.001+Tduration,[launchx launchvx launchy  
0 launchz launchvz]);
```

```
sizepvxyzT=size(pvxyzT);
```

```
lastxT=pvxyzT(sizepvxyzT(1),1);  
lastvxT=pvxyzT(sizepvxyzT(1),2);
```

```
lastyT=pvxyzT(sizepvxyzT(1),3);  
lastvyT=pvxyzT(sizepvxyzT(1),4);
```

```
lastzT=pvxyzT(sizepvxyzT(1),5);  
lastvzT=pvxyzT(sizepvxyzT(1),6);
```

```
lasttxyzT=max(txyzT);
```

```
%Determine if X, Y, or Z velocity after thrust is negative  
%If X, Y, or Z velocity is negative, you will make it and  
%and the initial position of the nonthrust phase positive.  
%If X, Y, or Z velocity is positive already, this will simply  
%multiply the initial position and velocity of the  
%nonthrust phase by 1.
```

```
posnegx=sign(lastvxT);  
lastxT=lastxT.*posnegx;  
lastvxT=lastvxT.*posnegx;
```

```
posnegy=sign(lastvyT);  
lastyT=lastyT.*posnegy;  
lastvyT=lastvyT.*posnegy;
```

```
posnegz=sign(lastvzT);  
lastzT=lastzT.*posnegz;  
lastvzT=lastvzT.*posnegz;
```

```
end;
```

```
%Expendable without thrust
```

```
%Define variables in ODE23 integraton step below if there is no  
%thrust on expendable after it is launched.
```

```
if Tduration==0 | R_Thrust==0;  
lasttxyzT=launch_time-.001;
```

```

        lastxT=launchx;
        lastyT=launchy;
        lastzT=launchz;

lastvxT=launchvx+muzzle_vel*sin(Phi_Angle)*cos(Theta_Angle);
lastvyT=muzzle_vel*sin(Phi_Angle)*sin(Theta_Angle);
lastvzT=launchvz+muzzle_vel*cos(Phi_Angle);

        %Determine if X,Y, or Z velocity is negative. If so, make it and the initial
        %position positive to afford proper integration.
        posnegx=sign(lastvxT);
        posnegy=sign(lastvyT);
        posnegz=sign(lastvzT);

        lastxT=lastxT.*posnegx;
        lastvxT=lastvxT.*posnegx;

        lastyT=lastyT.*posnegy;
        lastvyT=lastvyT.*posnegy;

        lastzT=lastzT.*posnegz;
        lastvzT=lastvzT.*posnegz;

    end;

[txyzNT,pvxyzNT]=ode23('dqxyz',lasttxyT,lasttxyT+.2,[lastxT,lastvxT,lastyT,lastvyT,lastzT,lastvzT]);

        %Multiply position and velocity after thrust by posneg
        %correction factor above to return position and velocity
        %in the nonthrust phase back to their proper direction.
        pvxyzNT(:,1)=pvxyzNT(:,1).*posnegx;
        pvxyzNT(:,2)=pvxyzNT(:,2).*posnegx;

        pvxyzNT(:,3)=pvxyzNT(:,3).*posnegy;
        pvxyzNT(:,4)=pvxyzNT(:,4).*posnegy;

        pvxyzNT(:,5)=pvxyzNT(:,5).*posnegz;
        pvxyzNT(:,6)=pvxyzNT(:,6).*posnegz;

        %If Thrust sphere has thrust, Remove repeated data from txNT and pvxNT data
        if Tduration~=0 | R_Thrust~=0;
            txyzNT(1)=[];
            pvxyzNT(1,:)=[];
        end

txyz=[txyzT;txyzNT];
pvxyz=[pvxyzT;pvxyzNT];

txyz=txyz';
pvxyz=pvxyz';

exppvx=[txyz;pvxyz(1:2,:)];
exppvy=[txyz;pvxyz(3:4,:)];
exppvz=[txyz;pvxyz(5:6,:)];

```

```
%  
if number ==1  
exppv1=exppv; exppv1=exppv; exppv1=exppv;  
elseif number ==2  
exppv2=exppv; exppv2=exppv; exppv2=exppv;  
elseif number ==3  
exppv3=exppv; exppv3=exppv; exppv3=exppv;  
elseif number ==4  
exppv4=exppv; exppv4=exppv; exppv4=exppv;  
elseif number ==5  
exppv5=exppv; exppv5=exppv; exppv5=exppv;  
elseif number ==6  
exppv6=exppv; exppv6=exppv; exppv6=exppv;  
elseif number ==7  
exppv7=exppv; exppv7=exppv; exppv7=exppv;  
end;
```

```
r(number)=round(opertime/.001)*.001;
```

```
end
```

```
end
```

```
function r=gtoptram(u)
```

```
%*****  
% gtoptram.m  
% Used in BLOCK:Go_operational_multiple  
%  
% Authors: Capt. Joel Hagan & Capt Brian Peterson, USAF  
%         GSE-95D Air Force Institute of Technology  
% Language: Matlab  
% Project: AKKCT (Aircraft Kintetic Kill Countermeasures Technology)  
% Last Updated: 14 SEP 95  
%  
% Function: This function calculates the trajectory and velocity of the  
%           expendable once it is operational. Once the global time reaches  
%           the operational time, the position and velocity of the expendable  
%           are used to calculate the trajectory for the expendable using the new  
%           expendable characteristics. This is done using ODE23 in the simulation  
%           so again, a global variable (onceito) is used to prevent the calculation  
%           from happening twice. The results are stored in global variables  
%           expppvopr(1-7),expppvopr(1-7),expppvopr(1-7).  
%           No noise is entered into the expendable trajectory in this function.  
%           A flag is set from -1 to 1 for each expendable when it goes  
%           operational and from 1 to 100 when it is no longer operational.  
%  
%*****
```

```
%u1=time  
%u2-8=operational time  
%u9-50=exp x,vx,y,vy,z,vz  
%u51=opertime_duration  
%u52-58=flag
```

```
%r1-7=flags
```

```
global expppvopr1 expppvopr2 expppvopr3  
global expppvopr4 expppvopr5 expppvopr6 expppvopr7  
global onceito
```

```
oper_duration=u(51);
```

```
timer=.001*round(u(1)/.001);
```

```
for number=1:7,  
r(number)=u(51+number);  
opertime=u(number+1);
```

```

if timer==(0.001*round((opertime+oper_duration)/.001))
    r(number)=100;
end;
if (timer==opertime) & (onceito(number)==1)
r(number)=1;
end;
if (timer==opertime) & (onceito(number)==0)
onceito(number)=1;
timer
number

operxexp=u(9+(number-1)*6);
opervxexp=u(10+(number-1)*6);
operyexp=u(11+(number-1)*6);
opervyexp=u(12+(number-1)*6);
operzexp=u(13+(number-1)*6);
opervzexp=u(14+(number-1)*6);

%Determine x, y, & z position and velocity of expendable after it is operational

    %Determine if x, y, or z velocity after expendable is
    %operational is negative
    %If x,y, or z velocity is negative, you will make it
    %and the initial position positive.
    %If x, y, or z velocity is already positive, this will simply
    %multiply the initial position and velocity of the by 1
    posnegxopr=sign(opervxexp);
    operxexp=operxexp.*posnegxopr;
    opervxexp=opervxexp.*posnegxopr;

    posnegyopr=sign(opervyexp);
    operyexp=operyexp.*posnegyopr;
    opervyexp=opervyexp.*posnegyopr;

    posnegzopr=sign(opervzexp);
    operzexp=operzexp.*posnegzopr;
    opervzexp=opervzexp.*posnegzopr;

[txyz_opr,pvxyz_opr]=ode23('dqxyzopr',opertime-.001,opertime-
.001+oper_duration,[operxexp,opervxexp,operyexp,opervyexp,operzexp,opervzexp]);

    %Multiply position and velocity after thrust by posneg
    %correction factor above to return position and velocity
    %in the nonthrust phase back to their proper direction.
    pvxyz_opr(:,1)=pvxyz_opr(:,1).*posnegxopr;
    pvxyz_opr(:,2)=pvxyz_opr(:,2).*posnegxopr;

    pvxyz_opr(:,3)=pvxyz_opr(:,3).*posnegyopr;
    pvxyz_opr(:,4)=pvxyz_opr(:,4).*posnegyopr;

    pvxyz_opr(:,5)=pvxyz_opr(:,5).*posnegzopr;
    pvxyz_opr(:,6)=pvxyz_opr(:,6).*posnegzopr;

%If integration routine is unable to converge resulting in the attempted
%integration time steps taken by ode23 converging to the same value, take all

```

```

%of the data after the time at which ode23 can't converge and throw it out.
%Any values matlab needs for a time after the data you threw out will be
%linearly extrapolated using the last two good data points
sizetxyz_opr=size(txyz_opr);
xyz=1;
while xyz<sizetxyz_opr(1,1)-1;
    if abs(txyz_opr(xyz)-txyz_opr(xyz+1))<.00001;
        txyz_opr=txyz_opr(1:xyz);
        pvxyz_opr=pvxyz_opr(1:xyz,:);
        xyz=sizetxyz_opr(1,1);
    end
    xyz=xyz+1;
end

txyz_opr=txyz_opr';
pvxyz_opr=pvxyz_opr';

timesize=size(txyz_opr,2);
txyz_opr(timesize+1)=txyz_opr(timesize)+25;
pvxyz_opr(1:6,timesize+1)=pvxyz_opr(1:6,timesize);

exppvxopr=[txyz_opr;pvxyz_opr(1:2,:)];
exppvyopr=[txyz_opr;pvxyz_opr(3:4,:)];
exppvzopr=[txyz_opr;pvxyz_opr(5:6,:)];

if number ==1
exppvxopr1=exppvxopr; exppvyopr1=exppvyopr; exppvzopr1=exppvzopr;
elseif number ==2
exppvxopr2=exppvxopr; exppvyopr2=exppvyopr; exppvzopr2=exppvzopr;
elseif number ==3
exppvxopr3=exppvxopr; exppvyopr3=exppvyopr; exppvzopr3=exppvzopr;
elseif number ==4
exppvxopr4=exppvxopr; exppvyopr4=exppvyopr; exppvzopr4=exppvzopr;
elseif number ==5
exppvxopr5=exppvxopr; exppvyopr5=exppvyopr; exppvzopr5=exppvzopr;
elseif number ==6
exppvxopr6=exppvxopr; exppvyopr6=exppvyopr; exppvzopr6=exppvzopr;
elseif number ==7
exppvxopr7=exppvxopr; exppvyopr7=exppvyopr; exppvzopr7=exppvzopr;
end;

end;
end;

```



```

function r=exppos1(u)

%*****
% exppos1.m
% Used in BLOCK:Expendable1
%
% Authors: Capt. Joel Hagan & Capt Brian Peterson, USAF
%         GSE-95D Air Force Institute of Technology
% Language: Matlab
% Project: AKKCT (Aircraft Kintetic Kill Countermeasures Technology)
% Last Updated: 14 SEP 95
%
% Function: This function return the position and velocity of the
%           expendable during the time between launch and when it goes
%           operational (if statement #1) and during the time it is
%           operational (if statement #2). It does so by interpolating
%           from the global look-up tables (exppvy and exppvyopr)
%           generated in lchtraj.m and gtoptraj.m
%*****

%u1=operational flag (-1 before operational
%           1 while operational
%           `100 afterwards)
%u2=launch flag -1 before launch 1 after
%u3=time
%u4-6= last position change due to wash noise (x,y,z)
%u7-9=noise wash standard deviation;
%u10=wash noise duration
global exppvxopr1 exppvyopr1 exppvzopr1
global exppvx1 exppvy1 exppvz1 lchtimem

r=[0 0 0 0 0 0 0 0 0];

time=u(3);

if ((time>=lchtimem(1)) & (time<=(lchtimem(1)+u(10))))
    noiseadd=[u(7)*randn u(8)*randn u(9)*randn];
else
    noiseadd=[0 0 0];
end;
r(7)=u(4)+noiseadd(1);
r(8)=u(5)+noiseadd(2);
r(9)=u(6)+noiseadd(3);

if (u(1)<0) & (u(2)>0) %between launch and when it goes operational
r(1)=interp1(exppvx1(1,:),exppvx1(2,:),time)+r(7);
r(2)=interp1(exppvx1(1,:),exppvx1(3,:),time);
r(3)=interp1(exppvy1(1,:),exppvy1(2,:),time)+r(8);
r(4)=interp1(exppvy1(1,:),exppvy1(3,:),time);
r(5)=interp1(exppvz1(1,:),exppvz1(2,:),time)+r(9);
r(6)=interp1(exppvz1(1,:),exppvz1(3,:),time);
elseif (u(1)>0) & (u(2)>0) % for duration of when it is operational
r(1)=interp1(exppvxopr1(1,:),exppvxopr1(2,:),time);

```

```
r(2)=interp(exppvxopr1(1,:),exppvxopr1(3,:),time);  
r(3)=interp(exppvyopr1(1,:),exppvyopr1(2,:),time);  
r(4)=interp(exppvyopr1(1,:),exppvyopr1(3,:),time);  
r(5)=interp(exppvzopr1(1,:),exppvzopr1(2,:),time);  
r(6)=interp(exppvzopr1(1,:),exppvzopr1(3,:),time);  
end;
```

```

function r=expos2(u)

%*****
% expos2.m
% Used in BLOCK:Expendable2
%
% Authors: Capt. Joel Hagan & Capt Brian Peterson, USAF
%         GSE-95D Air Force Institute of Technology
% Language: Matlab
% Project: AKKCT (Aircraft Kintetic Kill Countermeasures Technology)
% Last Updated: 14 SEP 95
%
% Function: This function return the position and velocity of the
%           expendable during the time between launch and when it goes
%           operational (if statement #1) and during the time it is
%           operational (if statement #2). It does so by interpolating
%           from the global look-up tables (exppv2 and expv2opr)
%           generated in Inchtraj.m and gtoptraj.m
%*****

%u1=operational flag (-1 before operational
%       1 while operational
%       `100 afterwards)
%u2=launch flag -1 before launch 1 after
%u3=time
%u4-6= last position change due to wash noise (x,y,z)
%u7-9=noise wash standard deviation;
%u10=wash noise duration
global expvxopr2 expvyopr2 expvzopr2
global expvx2 expvy2 expvz2 Inchtimem

r=[0 0 0 0 0 0 0 0];

time=u(3);

if ((time>=Inchtimem(2)) & (time<=(Inchtimem(2)+u(10))))
    noiseadd=[u(7)*randn u(8)*randn u(9)*randn];
else
    noiseadd=[0 0 0];
end;
r(7)=u(4)+noiseadd(1);
r(8)=u(5)+noiseadd(2);
r(9)=u(6)+noiseadd(3);

if (u(1)<0)& (u(2)>0) %between launch and when it goes operational
r(1)=interp1(expvx2(1,:),expvx2(2,:),time)+r(7);
r(2)=interp1(expvx2(1,:),expvx2(3,:),time);
r(3)=interp1(expvy2(1,:),expvy2(2,:),time)+r(8);
r(4)=interp1(expvy2(1,:),expvy2(3,:),time);
r(5)=interp1(expvz2(1,:),expvz2(2,:),time)+r(9);
r(6)=interp1(expvz2(1,:),expvz2(3,:),time);
elseif (u(1)>0)& (u(2)>0) % for duration of when it is operational
r(1)=interp1(expvxopr2(1,:),expvxopr2(2,:),time);

```

```
r(2)=interp1(exppvxopr2(1,:),exppvxopr2(3,:),time);  
r(3)=interp1(exppvyopr2(1,:),exppvyopr2(2,:),time);  
r(4)=interp1(exppvyopr2(1,:),exppvyopr2(3,:),time);  
r(5)=interp1(exppvzopr2(1,:),exppvzopr2(2,:),time);  
r(6)=interp1(exppvzopr2(1,:),exppvzopr2(3,:),time);  
end;
```

```

function r=expos3(u)

%*****
% expos3.m
% Used in BLOCK:Expendable3
%
% Authors: Capt. Joel Hagan & Capt Brian Peterson, USAF
%         GSE-95D Air Force Institute of Technology
% Language: Matlab
% Project: AKKCT (Aircraft Kintetic Kill Countermeasures Technology)
% Last Updated: 14 SEP 95
%
% Function: This function return the position and velocity of the
%           expendable during the time between launch and when it goes
%           operational (if statement #1) and during the time it is
%           operational (if statement #2). It does so by interpolating
%           from the global look-up tables (exppv3 and expv3opr)
%           generated in Inchtraj.m and gtoptraj.m
%*****

%u1=operational flag (-1 before operational
%           1 while operational
%           ` 100 afterwards)
%u2=launch flag -1 before launch 1 after
%u3=time
%u4-6= last position change due to wash noise (x,y,z)
%u7-9=noise wash standard deviation;
%u10=wash noise duration
global expvxopr3 expvyopr3 expvzopr3
global expvx3 expvy3 expvz3 Inchtmem

r=[0 0 0 0 0 0 0 0];

time=u(3);

if ((time>=Inchtmem(3)) & (time<=(Inchtmem(3)+u(10))))
    noiseadd=[u(7)*randn u(8)*randn u(9)*randn];
else
    noiseadd=[0 0 0];
end;
r(7)=u(4)+noiseadd(1);
r(8)=u(5)+noiseadd(2);
r(9)=u(6)+noiseadd(3);

if (u(1)<0) & (u(2)>0) %between launch and when it goes operational
r(1)=interp1(expvx3(1,:),expvx3(2,:),time)+r(7);
r(2)=interp1(expvx3(1,:),expvx3(3,:),time);
r(3)=interp1(expvy3(1,:),expvy3(2,:),time)+r(8);
r(4)=interp1(expvy3(1,:),expvy3(3,:),time);
r(5)=interp1(expvz3(1,:),expvz3(2,:),time)+r(9);
r(6)=interp1(expvz3(1,:),expvz3(3,:),time);
elseif (u(1)>0) & (u(2)>0) % for duration of when it is operational
r(1)=interp1(expvxopr3(1,:),expvxopr3(2,:),time);

```

```
r(2)=interp1(exppvxopr3(1,:),exppvxopr3(3,:),time);
r(3)=interp1(exppvyopr3(1,:),exppvyopr3(2,:),time);
r(4)=interp1(exppvyopr3(1,:),exppvyopr3(3,:),time);
r(5)=interp1(exppvzopr3(1,:),exppvzopr3(2,:),time);
r(6)=interp1(exppvzopr3(1,:),exppvzopr3(3,:),time);
end;
```

```

function r=expos4(u)

%*****
% expos4.m
% Used in BLOCK:Expendable4
%
% Authors: Capt. Joel Hagan & Capt Brian Peterson, USAF
%         GSE-95D Air Force Institute of Technology
% Language: Matlab
% Project: AKKCT (Aircraft Kintetic Kill Countermeasures Technology)
% Last Updated: 14 SEP 95
%
% Function: This function return the position and velocity of the
%           expendable during the time between launch and when it goes
%           operational (if statement #1) and during the time it is
%           operational (if statement #2). It does so by interpolating
%           from the global look-up tables (exppv4 and expvz4)
%           generated in Inchtraj.m and gtoptraj.m
%*****

%u1=operational flag (-1 before operational
%       1 while operational
%       ` 100 afterwards)
%u2=launch flag -1 before launch 1 after
%u3=time
%u4-6= last position change due to wash noise (x,y,z)
%u7-9=noise wash standard deviation;
%u10=wash noise duration
global expvxopr4 expvyopr4 expvzopr4
global expvx4 expvy4 expvz4 Inchtimem

r=[0 0 0 0 0 0 0 0];

time=u(3);

if ((time>=Inchtimem(4)) & (time<=(Inchtimem(4)+u(10))))
    noiseadd=[u(7)*randn u(8)*randn u(9)*randn];
else
    noiseadd=[0 0 0];
end;
r(7)=u(4)+noiseadd(1);
r(8)=u(5)+noiseadd(2);
r(9)=u(6)+noiseadd(3);

if (u(1)<0)& (u(2)>0) %between launch and when it goes operational
r(1)=interp1(expvx4(1,:),expvx4(2,:),time)+r(7);
r(2)=interp1(expvx4(1,:),expvx4(3,:),time);
r(3)=interp1(expvy4(1,:),expvy4(2,:),time)+r(8);
r(4)=interp1(expvy4(1,:),expvy4(3,:),time);
r(5)=interp1(expvz4(1,:),expvz4(2,:),time)+r(9);
r(6)=interp1(expvz4(1,:),expvz4(3,:),time);
elseif (u(1)>0)& (u(2)>0) % for duration of when it is operational
r(1)=interp1(expvxopr4(1,:),expvxopr4(2,:),time);

```

```
r(2)=interp1(exppvxopr4(1,:),exppvxopr4(3,:),time);  
r(3)=interp1(exppvyopr4(1,:),exppvyopr4(2,:),time);  
r(4)=interp1(exppvyopr4(1,:),exppvyopr4(3,:),time);  
r(5)=interp1(exppvzopr4(1,:),exppvzopr4(2,:),time);  
r(6)=interp1(exppvzopr4(1,:),exppvzopr4(3,:),time);  
end;
```



```

function r=expos5(u)

%*****
% expos5.m
% Used in BLOCK:Expendable5
%
% Authors: Capt. Joel Hagan & Capt Brian Peterson, USAF
%         GSE-95D Air Force Institute of Technology
% Language: Matlab
% Project: AKKCT (Aircraft Kintetic Kill Countermeasures Technology)
% Last Updated: 14 SEP 95
%
% Function: This function return the position and velocity of the
%           expendable during the time between launch and when it goes
%           operational (if statement #1) and during the time it is
%           operational (if statement #2). It does so by interpolating
%           from the global look-up tables (exppv5 and expvz5)
%           generated in lchtraj.m and gtoptraj.m
%*****

%u1=operational flag (-1 before operational
%       1 while operational
%       `100 afterwards)
%u2=launch flag -1 before launch 1 after
%u3=time
%u4-6= last position change due to wash noise (x,y,z)
%u7-9=noise wash standard deviation;
%u10=wash noise duration
global expvxopr5 expvyopr5 expvzopr5
global expvx5 expvy5 expvz5 lchtimem

r=[0 0 0 0 0 0 0 0];

time=u(3);

if ((time>=lchtimem(5)) & (time<=(lchtimem(5)+u(10))))
    noiseadd=[u(7)*randn u(8)*randn u(9)*randn];
else
    noiseadd=[0 0 0];
end;
r(7)=u(4)+noiseadd(1);
r(8)=u(5)+noiseadd(2);
r(9)=u(6)+noiseadd(3);

if (u(1)<0)& (u(2)>0) %between launch and when it goes operational
r(1)=interp1(expvx5(1,:),expvx5(2,:),time)+r(7);
r(2)=interp1(expvx5(1,:),expvx5(3,:),time);
r(3)=interp1(expvy5(1,:),expvy5(2,:),time)+r(8);
r(4)=interp1(expvy5(1,:),expvy5(3,:),time);
r(5)=interp1(expvz5(1,:),expvz5(2,:),time)+r(9);
r(6)=interp1(expvz5(1,:),expvz5(3,:),time);
elseif (u(1)>0)& (u(2)>0) % for duration of when it is operational
r(1)=interp1(expvxopr5(1,:),expvxopr5(2,:),time);

```

```
r(2)=interp1(exppvxopr5(1,:),exppvxopr5(3,:),time);  
r(3)=interp1(exppvyopr5(1,:),exppvyopr5(2,:),time);  
r(4)=interp1(exppvyopr5(1,:),exppvyopr5(3,:),time);  
r(5)=interp1(exppvzopr5(1,:),exppvzopr5(2,:),time);  
r(6)=interp1(exppvzopr5(1,:),exppvzopr5(3,:),time);  
end;
```

```

function r=expos6(u)

%*****
% expos6.m
% Used in BLOCK:Expendable6
%
% Authors: Capt. Joel Hagan & Capt Brian Peterson, USAF
%         GSE-95D Air Force Institute of Technology
% Language: Matlab
% Project: AKKCT (Aircraft Kintetic Kill Countermeasures Technology)
% Last Updated: 14 SEP 95
%
% Function: This function return the position and velocity of the
%           expendable during the time between launch and when it goes
%           operational (if statement #1) and during the time it is
%           operational (if statement #2). It does so by interpolating
%           from the global look-up tables (exppv6 and expv6)
%           generated in lchtraj.m and gtoptraj.m
%*****

%u1=operational flag (-1 before operational
%           1 while operational
%           `100 afterwards)
%u2=launch flag -1 before launch 1 after
%u3=time
%u4-6= last position change due to wash noise (x,y,z)
%u7-9=noise wash standard deviation;
%u10=wash noise duration
global expvxopr6 expvyopr6 expvzopr6
global expvx6 expvy6 expvz6 lchtime6

r=[0 0 0 0 0 0 0];

time=u(3);

if ((time>=lchtime6(6)) & (time<=(lchtime6(6)+u(10))))
    noiseadd=[u(7)*randn u(8)*randn u(9)*randn];
else
    noiseadd=[0 0 0];
end;
r(7)=u(4)+noiseadd(1);
r(8)=u(5)+noiseadd(2);
r(9)=u(6)+noiseadd(3);

if (u(1)<0)& (u(2)>0) %between launch and when it goes operational
r(1)=interp1(expvx6(1,:),expvx6(2,:),time)+r(7);
r(2)=interp1(expvx6(1,:),expvx6(3,:),time);
r(3)=interp1(expvy6(1,:),expvy6(2,:),time)+r(8);
r(4)=interp1(expvy6(1,:),expvy6(3,:),time);
r(5)=interp1(expvz6(1,:),expvz6(2,:),time)+r(9);
r(6)=interp1(expvz6(1,:),expvz6(3,:),time);
elseif (u(1)>0)& (u(2)>0) % for duration of when it is operational
r(1)=interp1(expvxopr6(1,:),expvxopr6(2,:),time);

```

```
r(2)=interp1(exppvxopr6(1,:),exppvxopr6(3,:),time);  
r(3)=interp1(exppvyopr6(1,:),exppvyopr6(2,:),time);  
r(4)=interp1(exppvyopr6(1,:),exppvyopr6(3,:),time);  
r(5)=interp1(exppvzopr6(1,:),exppvzopr6(2,:),time);  
r(6)=interp1(exppvzopr6(1,:),exppvzopr6(3,:),time);  
end;
```

```

function r=expos7(u)

%*****
% expos7.m
% Used in BLOCK:Expendable7
%
% Authors: Capt. Joel Hagan & Capt Brian Peterson, USAF
%         GSE-95D Air Force Institute of Technology
% Language: Matlab
% Project: AKKCT (Aircraft Kintetic Kill Countermeasures Technology)
% Last Updated: 14 SEP 95
%
% Function: This function return the position and velocity of the
%           expendable during the time between launch and when it goes
%           operational (if statement #1) and during the time it is
%           operational (if statement #2). It does so by interpolating
%           from the global look-up tables (exppv7 and exppvopr)
%           generated in lnchtraj.m and gtoptraj.m
%*****

%u1=operational flag (-1 before operational
%       1 while operational
%       ` 100 afterwards)
%u2=launch flag -1 before launch 1 after
%u3=time
%u4-6= last position change due to wash noise (x,y,z)
%u7-9=noise wash standard deviation;
%u10=wash noise duration
global exppvopr7 exppvopr7 exppvopr7
global exppv7 exppv7 exppv7 lnchtimem

r=[0 0 0 0 0 0 0 0 0];

time=u(3);

if ((time>=lnchtimem(7)) & (time<=(lnchtimem(7)+u(10))))
    noiseadd=[u(7)*randn u(8)*randn u(9)*randn];
else
    noiseadd=[0 0 0];
end;
r(7)=u(4)+noiseadd(1);
r(8)=u(5)+noiseadd(2);
r(9)=u(6)+noiseadd(3);

if (u(1)<0) & (u(2)>0) %between launch and when it goes operational
r(1)=interp1(exppv7(1,:),exppv7(2,:),time)+r(7);
r(2)=interp1(exppv7(1,:),exppv7(3,:),time);
r(3)=interp1(exppv7(1,:),exppv7(2,:),time)+r(8);
r(4)=interp1(exppv7(1,:),exppv7(3,:),time);
r(5)=interp1(exppv7(1,:),exppv7(2,:),time)+r(9);
r(6)=interp1(exppv7(1,:),exppv7(3,:),time);
elseif (u(1)>0) & (u(2)>0) % for duration of when it is operational
r(1)=interp1(exppvopr7(1,:),exppvopr7(2,:),time);

```

```
r(2)=interp1(exppvxopr7(1,:),exppvxopr7(3,:),time);  
r(3)=interp1(exppvyopr7(1,:),exppvyopr7(2,:),time);  
r(4)=interp1(exppvyopr7(1,:),exppvyopr7(3,:),time);  
r(5)=interp1(exppvzopr7(1,:),exppvzopr7(2,:),time);  
r(6)=interp1(exppvzopr7(1,:),exppvzopr7(3,:),time);  
end;
```

```

%*****
% getit.m
%
% Authors: Capt. Joel Hagan & Capt Brian Peterson, USAF
%         GSE-95D Air Force Institute of Technology
% Language: Matlab
% Project: AKKCT (Aircraft Kintetic Kill Countermeasures Technology)
% Last Updated: 14 SEP 95
%
% Function: This function is used to calculate the look-up
% tables for phi launch, theta launch, and time-to-target
% for the different expendables. Since the equations are so complex,
% it was impossible to implement them real-time into the simulation.
% The goal of the simulation was to be able to place the expendable
% at a certain location on the sphere around the aircraft. This
% point was referenced using phi and alpha. This was very difficult
% because the magnitude and duration of the thrust could vary,
% phi and theta could vary, and so could the time to get it to
% the point. The result was a very complex dynamic equation.
% It was determined that since 99% of the missiles entered
% the sphere within 1.5 degrees of phi=93.12. The target phi
% was set constant at 93.12. Obviously this is not the ideal
% situation to maximize the probability of hitting the missile
% but it was necessary in order to continue with the simulation.
% With Phi constant, theta and time-to-target were the only true
% variables and the launch phi, and theta and time-to-target
% could be calculated using the ODE23 function. Since the
% climb angle and aircraft velocity were assumed constant,
% these could be computed prior to simulation and put in a
% look-up table. This greatly decreased the run-time of the
% simulation
%
%*****

clear

%Define properties of sphere sphere

CD_sphere=.15;
S_sphere=.196;
W_sphere=10;
Rho_ambient=.002378;

global R_Thrust Phi_Angle Theta_Angle;
global CD_sphere S_sphere W_sphere Rho_ambient;

%Define variables
%m=mass of expendable, gamma=A/C flight path angle(in degrees),
%Vac=velocity of A/C when expendable is launched (ft/sec)
m=W_sphere/32.2;
gamma=15;
Vac=258;

%Define whether or not expendable is under thrust after it is launched

```

```

%by assigning proper values to the following three variables:
%t1=time of thrust burn (sec), R_Thrust=thrust with which expendable is
%launched(lbf), muzzle_vel=velocity at which expendable leaves launcher
%(ft/sec).
t1=0;
R_Thrust=0;
muzzle_vel=700;

%Convert degrees to radians
gammarad=gamma/57.3;

%Read input file
infid=fopen('inlaunch.txt','r');
[table,count]=fscanf(infid,'%f ');
status=fclose(infid);

%Open output file
outfid=fopen('outlaunc.txt','w');
fprintf(outfid,'phi_initial theta_initial phi theta t xdif ydif zdif \n');

%Assign each value from the input "table" data to a variable
%Each pass through the "for" loop reads in "sizetable(1)" variables
sizetable=size(table);

jh=0;
for pass=1:3:sizetable(1)

phitarget_initial=table(pass);
thetarget_initial=table(pass+1);
rtarget_initial=table(pass+2);

%Define initial guesses for launcher variables
%t=actual duration of expendable flight prior to intercepting target point,
%phi=angle (in degrees) measured from positive z axis pointing up showing
%where launcher is pointed, theta=angle (in degrees) measured from positive
%x axis pointing forward showing where launcher is pointed.
t=.435;
tinitial=t;
phi=phitarget_initial;
theta=thetarget_initial;

phidif=100000;
thetadif=100000;
rdif=100000;
xdif=100000;
ydif=100000;
zdif=100000;

%Define the maximum deviation of phi, theta, and range of the point in space the
%expendable hits relative to where you wanted it to hit
phi_tollerance=.2;
theta_tollerance=.2;
r_tollerance=.2;

%Iterate to find required phi, theta, and t of expendable launcher

```



```

count=1;
while abs(phidif)>phi_tolerance | abs(thetadif)>theta_tolerance | abs(rdif)>r_tolerance

%Convert degrees to radians
phirad=phi/57.3;
thetarad=theta/57.3;

%Define phirad and thetarad as being equal to two other variables. This was
%done because mess.m uses these variable names in dqx.m, dqxt.m, etc and I
%was too lazy to change the variable names in this file also
Phi_Angle=phirad;
Theta_Angle=thetarad;

phitarget_irad=phitarget_initial/57.3;
thetarget_irad=thetarget_initial/57.3;

%Determine X, Y, & Z position of target point in space relative to where
%A/C launched expendable

xtarget_final=rtarget_initial.*sin(phitarget_irad).*cos(thetarget_irad)+Vac*t*cos(gammarad);
ytarget_final=rtarget_initial.*sin(phitarget_irad).*sin(thetarget_irad);
ztarget_final=rtarget_initial.*cos(phitarget_irad)+Vac.*t.*sin(gammarad);

%Calculate final phi, theta and r for target

rtarget_final=((xtarget_final).^2+(ytarget_final).^2+(ztarget_final).^2).^5;
thetarget_final=atan2(ytarget_final,xtarget_final);
resultxy_target_final=((xtarget_final).^2+(ytarget_final).^2).^5;
phitarget_final=atan2(resultxy_target_final,ztarget_final);

%Determine X position of expendable
%Expendable under thrust
if t1~=0 & R_Thrust~=0;
    vxinitial=Vac*cos(gammarad);
    [txT,pvxT]=ode23('dqxt',0,t1,[0 vxinitial]);
    sizepvxT=size(pvxT);
    lastxT=pvxT(sizepvxT(1),1);
    lastvxT=pvxT(sizepvxT(1),2);
    lasttxT=max(txT);

    %Determine if X velocity after thrust is negative
    %If X velocity is negative, you will make it and
    %and the initial position of the nonthrust phase positive.
    %If X velocity is positive already, this will simply
    %multiply the initial position and velocity of the
    %nonthrust phase by 1.
    posnegx=sign(lastvxT);
    lastxT=lastxT.*posnegx;
    lastvxT=lastvxT.*posnegx;
end;

%Expendable without thrust
%Define variables in ODE23 integraton step below if there is no
%thrust on expendable after it is launched.
if t1==0 | R_Thrust==0;

```

```

        lastxT=0;
        lastvT=0;
        lastvxT=Vac*cos(gammarad)+muzzle_vel*sin(phirad)*cos(thetarad);
        %Determine if X velocity is negative. If so, make it and the initial
        %position positive to afford proper integration.
        posnegx=sign(lastvxT);
        lastxT=lastxT.*posnegx;
        lastvxT=lastvxT.*posnegx;
        end;

[txNT,pvxNT]=ode23('dqx',lastxT,lastxT+20,[lastxT,lastvxT]);

        %Multiply position and velocity after thrust by posneg
        %correction factor above to return position and velocity
        %in the nonthrust phase back to their proper direction.
        pvxNT(:,1)=pvxNT(:,1).*posnegx;
        pvxNT(:,2)=pvxNT(:,2).*posnegx;

        %Remove repeated data from txNT and pvxNT data
        txNT(1)=[];
        pvxNT(1,:)=[];

        tx=[txT;txNT];
        pvx=[pvxT;pvxNT];

tx=tx';
pvx=pvx';
exppx=[tx;pvx(1,:)];
xvelexp=pvx(2,:);

%Determine Y position of expendable
%Expendable under thrust
if t1~=0 & R_Thrust~=0;

        [tyT,pvyT]=ode23('dqyt',0,t1,[0 0]);
        sizepvyT=size(pvyT);
        lastyT=pvyT(sizepvyT(1),1);
        lastvyT=pvyT(sizepvyT(1),2);
        lasttyT=max(tyT);

        %Determine if Y velocity after thrust is negative
        %If Y velocity is negative, you will make it and
        %and the initial position of the nonthrust phase positive.
        %If Y velocity is positive already, this will simply
        %multiply the initial position and velocity of the
        %nonthrust phase by 1.
        posnegy=sign(lastvyT);
        lastyT=lastyT.*posnegy;
        lastvyT=lastvyT.*posnegy;

end;

%Expendable without thrust
%Define variables in ODE23 integraton step below if there is no
%thrust on expendable after it is launched.
        if t1==0 | R_Thrust==0;

```

```

        lastyT=0;
        lastyT=0;
        lastvyT=muzzle_vel*sin(phirad)*sin(thetarad);
        %Determine if Y velocity is negative. If so, make it and the initial
        %position positive to afford proper integration.
        posnegy=sign(lastvyT);
        lastyT=lastyT.*posnegy;
        lastvyT=lastvyT.*posnegy;
        end;

[tyNT,pvyNT]=ode23('dqy',lastyT,lastyT+20,[lastyT,lastvyT]);

        %Multiply position and velocity after thrust by posneg
        %correction factor above to return position and velocity
        %in the nonthrust phase back to their proper direction.
        pvyNT(:,1)=pvyNT(:,1).*posnegy;
        pvyNT(:,2)=pvyNT(:,2).*posnegy;

        %Remove repeated data from txNT and pvxNT data
        tyNT(1)=[];
        pvyNT(1,:)=[];

        ty=[tyT;tyNT];
        pvy=[pvyT;pvyNT];

ty=ty';
pvy=pvy';
exppy=[ty;pvy(1,:)];
yvelexp=pvy(2,:);

%Determine Z position of expendable
%Expendable under thrust
if t1~=0 & R_Thrust~=0;

        detectvz=Vac*sin(gammarad);
        [tzT,pvzT]=ode23('dqzt',0,t1,[0 detectvz]);
        sizepvzT=size(pvzT);
        lastzT=pvzT(sizepvzT(1),1);
        lastvzT=pvzT(sizepvzT(1),2);
        lasttzT=max(tzT);

        %Determine if Y velocity after thrust is negative
        %If Y velocity is negative, you will make it and
        %and the initial position of the nonthrust phase positive.
        %If Y velocity is positive already, this will simply
        %multiply the initial position and velocity of the
        %nonthrust phase by 1.
        posnegz=sign(lastvzT);
        lastzT=lastzT.*posnegz;
        lastvzT=lastvzT.*posnegz;

end;

%Expendable without thrust
%Define variables in ODE23 integraton step below if there is no
%thrust on expendable after it is launched.

```

```

if t1==0 | R_Thrust==0;
    lasttzT=0;
    lastzT=0;
    lastvzT=Vac*sin(gammarad)+muzzle_vel*cos(phirad);
    %Determine if Z velocity is negative. If so, make it and the initial
    %position positive to afford proper integration.
    posnegz=sign(lastvzT);
    lastzT=lastzT.*posnegz;
    lastvzT=lastvzT.*posnegz;
end;

[tzNT,pvzNT]=ode23('dqz',lasttzT,lasttzT+20,[lastzT,lastvzT]);

%Multiply position and velocity after thrust by posneg
%correction factor above to return position and velocity
%in the nonthrust phase back to their proper direction.
pvzNT(:,1)=pvzNT(:,1).*posnegz;
pvzNT(:,2)=pvzNT(:,2).*posnegz;

%Remove repeated data from txNT and pvxNT data
tzNT(1)=[];
pvzNT(1,:)=[];

tz=[tzT;tzNT];
pvz=[pvzT;pvzNT];

tz=tz';
pvz=pvz';
exppz=[tz;pvz(1,:)];
zvelexp=pvz(2,:);

%Calculate X, Y, & Z position at the specified time t
xposexp=spline(exppx(1,:),exppx(2,:),t);
yposexp=spline(exppy(1,:),exppy(2,:),t);
zposexp=spline(exppz(1,:),exppz(2,:),t);

%Calculate difference between X, Y, & Z position of expendable and X, Y, & Z
%position of target in space.
xdif=xtarget_final-xposexp;
ydif=ytarget_final-yposexp;
zdif=ztarget_final-zposexp;

%Calculate r, phi, & theta for expendable at time t (phi & theta in rad)
rexp=((xposexp).^2+(yposexp).^2+(zposexp)^2).^5;
thetaexp=atan2(yposexp,xposexp);
resultxy=((xposexp).^2+(yposexp).^2).^5;
phiexp=atan2(resultxy,zposexp);

%Convert radians to degrees
phiexpdeg=phiexp.*57.3;
thetaexpdeg=thetaexp.*57.3;

```

```

%Calculate difference between r, phi & theta for expendable and target point
%(angles in degrees)

rdif=rexp-rtarget_final
phidif=phiexpdeg-(phitarget_final*57.3)
thetadif=thetaexpdeg-(thetatarget_final*57.3)

%Define new guess for phi, theta, and t
if count<=20
    if abs(phidif)>phi_tolerance;
        phi=phi-abs(phidif);
    end;

    if abs(thetadif)>theta_tolerance;
        theta=theta-abs(thetadif);
    end;

    if abs(phidif)<phi_tolerance & abs(thetadif)<theta_tolerance & abs(rdif)>r_tolerance;
        t=abs((t./rexp).*rtarget_final);
        %t=t+sign(rtarget_final-rexp)*.0001;
    end;
elseif count==20
    phi=phitarget_initial;
    theta=thetatarget_initial;
    t=tinitial;
elseif count>20 & count <=40
    if abs(phidif)>phi_tolerance;
        phi=phi+abs(phidif);
    end;

    if abs(thetadif)>theta_tolerance;
        theta=theta+abs(thetadif);
    end;

    if abs(phidif)<phi_tolerance & abs(thetadif)<theta_tolerance & abs(rdif)>r_tolerance;
        t=abs((t./rexp).*rtarget_final);
        %t=t+sign(rtarget_final-rexp)*.0001;
    end;

elseif count >40 & count <=60
    if abs(phidif)>phi_tolerance;
        phi=phi-(phidif);
    end;

    if abs(thetadif)>theta_tolerance;
        theta=theta-(thetadif);
    end;

    if abs(phidif)<phi_tolerance & abs(thetadif)<theta_tolerance & abs(rdif)>r_tolerance;
        t=abs((t./rexp).*rtarget_final);
        %t=t+sign(rtarget_final-rexp)*.0001;
    end;
elseif count==60
    phi=phitarget_initial;
    theta=thetatarget_initial;

```

```

        t=initial;
elseif count>60 & count <=80
    if abs(phidif)>phi_tolerance;
        phi=phi+(phidif);
    end;

    if abs(thetadif)>theta_tolerance;
        theta=theta+(thetadif);
    end;

    if abs(phidif)<phi_tolerance & abs(thetadif)<theta_tolerance & abs(rdif)>r_tolerance;
        t=abs((t./rexp).*rtarget_final);
        %t=t+sign(rtarget_final-rexp)*.0001;
    end;
else
    phidif=0;
    phi=0;
    thetadif=0;
    theta=0;
    rdif=0;
    t=0;
end

completed_in=jh
count=count+1;
end

%Write final differences between target and expendable to file
output=[phitarget_initial thetatarget_initial phi theta t xdif ydif zdif];
fprintf(outfid,'%11.3f %13.3f %6.3f %6.3f %6.4f %6.3f %6.3f %6.3f %6.3f \n', output);

jh=jh+1;

end
status=fclose(outfid);

```

```

%*****
% decodefl.m
%
%
% Authors: Capt. Joel Hagan & Capt Brian Peterson, USAF
%         GSE-95D Air Force Institute of Technology
% Language: Matlab
% Project: AKKCT (Aircraft Kintetic Kill Countermeasures Technology)
% Last Updated: 14 SEP 95
%
% Function: This m-file allows you to easily extract the Probability
% of kills from a series of simulation runs. This considers this
% missile dead if it hit the expendable anywhere. The data from
% the simulation will actually give a range from 0 to 1 for each
% simulation depending on far from center of the expendable the
% missile was when it hit (i.e. .1 means it hit near the edge &
% 1 means it hit very close to center). With the multiple shot,
% the hit check uses a radial distance from the center of each expendable
% so it may appear to have hit multiple expendables. While this allows
% it to be theoretically possible for this simulation to register a hit
% the expendable falls quickly in front of the missile, but the missile
% misses it, the expendable would have to be falling far faster than
% any which are feasible to use.
% To use this file, put the data files in the same directory as this files,
% list them in the infile variables, and specify how many there are. All
% files names in each variable must be of the same length.
%
%*****
clear;

% single expendable simulations
infile=['s580.txt' 's581.txt' 's582.txt' 's583.txt' 's584.txt' 's585.txt'...
        's590.txt' 's591.txt' 's592.txt' 's593.txt' 's594.txt' 's595.txt'...
        's680.txt' 's681.txt' 's682.txt' 's683.txt' 's684.txt' 's685.txt'...
        's690.txt' 's691.txt' 's692.txt' 's693.txt' 's694.txt' 's695.txt' ];
numsingles=24;
filelengths=8; %include .txt (4) characters

% multiple expendable simulations
minfile=['t2e6m.txt' 't2e7m.txt' 't2e8m.txt' 't4e6m.txt' 't4e7m.txt' 't4e8m.txt' 't5e6m.txt' 't5e7m.txt'
't5e8m.txt'];
nummults=0;
filelengthm=9; %include .txt (4) characters

if numsingles>0

for i=1:numsingles,

infid=fopen(infile((i-1)*filelengths+1:i*filelengths),'r');
[table,count]=fscanf(infid,'%f ');
status=fclose(infid);
misses=0;
hits=0;
bad=0;
row=size(table,1)/19;

```

```

row;
table=reshape(table,row,19);
for j=1:row,
    p=table((j-1)*19+1);
    if p==0
        misses=misses+1;
    elseif p==-1
        bad=bad+1;
    else
        hits=hits+1;
    end;
end;
PK(i,1)=hits;
PK(i,2)=misses;
PK(i,3)=bad;
PK(i,4)=hits/row;

end;
end;
if nummults>0

for i=1:nummults;
infid=fopen(minfile((i-1)*filelengthm+1:i*filelengthm),'r');
[mtable,mcount]=fscanf(infid,'%f ');
status=fclose(infid);
mmisses=0;
mhits=0;
mbad=0;
mrow=size(mtable,1)/49;

mtable=reshape(mtable,49,mrow);

for j=1:mrow,
temp=0;
if mtable(j,1)==-1
    mbad=mbad+1;
else for k=1:7,
    if (mtable(j,k)~=0)
        temp=1;
    end;
end;
if temp==0
    mmisses=mmisses+1;
else
    mhits=mhits+1;
end;
end;
end;

PK(i+numsingles,1)=mhits;
PK(i+numsingles,2)=mmisses;
PK(i+numsingles,3)=mbad;
PK(i+numsingles,4)=mhits/mrow;
end;
end;

```

end;

REPORT DOCUMENTATION PAGE

Form Approved
OMB No. 0704-0188

Public reporting burden for this collection of information is estimated to average 1 hour per response, including the time for reviewing instructions, searching existing data sources, gathering and maintaining the data needed, and completing and reviewing the collection of information. Send comments regarding this burden estimate or any other aspect of this collection of information, including suggestions for reducing this burden, to Washington Headquarters Services, Directorate for Information Operations and Reports, 1215 Jefferson Davis Highway, Suite 1204, Arlington, VA 22202-4302, and to the Office of Management and Budget, Paperwork Reduction Project (0704-0188), Washington, DC 20503.

1. AGENCY USE ONLY (Leave blank)		2. REPORT DATE December 1995	3. REPORT TYPE AND DATES COVERED Technical Report; Thesis	
4. TITLE AND SUBTITLE A SYSTEMS ENGINEERING APPROACH TO AIRCRAFT KINETIC KILL COUNTERMEASURES TECHNOLOGY: DEVELOPMENT OF AN ACTIVE AIRCRAFT DEFENSE SYSTEM FOR THE C/KC-135 AIRCRAFT			5. FUNDING NUMBERS	
6. AUTHOR(S) Captain Mark Cherry, Major Bruce DeWitt, Captain Christopher Dusseault, Captain Joel Hagan Captain Brian Peterson				
7. PERFORMING ORGANIZATION NAME(S) AND ADDRESS(ES) Air Force Institute of Technology, WPAFB OH 45433-6583			8. PERFORMING ORGANIZATION REPORT NUMBER AFIT/GSE/ENG/95D-01	
9. SPONSORING/MONITORING AGENCY NAME(S) AND ADDRESS(ES) WL/AAWD-2 Wright-Patterson AFB, OH 45433-7521			10. SPONSORING/MONITORING AGENCY REPORT NUMBER	
11. SUPPLEMENTARY NOTES				
12a. DISTRIBUTION/AVAILABILITY STATEMENT Approved for public release; Distribution Unlimited			12b. DISTRIBUTION CODE	
13. ABSTRACT (Maximum 200 words) Modern Surface to Air Missiles (SAMs) present a significant threat to today's military and civilian aircraft. Current countermeasure systems such as flares and chaff rely on decoying the missile threat and do not provide adequate protection against advanced computerized missiles (Schaffer, 1993:1). An aircraft defense system that actively seeks out and defeats an incoming missile by placing a physical barrier in the missile's path offers a promising alternative to current countermeasures technology. This thesis reports the preliminary design of an active aircraft defense system for the protection of the C/KC-135 aircraft from SAMs. The developed system utilizes a kinetic kill mechanism to protect the aircraft from shoulder launched missiles while the aircraft is in the takeoff and climb-out configurations. Both smart anti-missile expendables and dumb projectile expendables are evaluated. The iterative Systems Engineering approach is used to narrow the solution set to the optimal design. The final outcome is the refined design of two candidate aircraft defense system employing a kinetic kill mechanism. Both systems utilize a modified ultra-violet tracker and employ one of two types of nets, one made out of Detonation Cord and the other made out of Spectra.				
14. SUBJECT TERMS KC-135, Aircraft Defense, Active Aircraft Defense, Kinetic Kill			15. NUMBER OF PAGES 475	
			16. PRICE CODE	
17. SECURITY CLASSIFICATION OF REPORT UNCLASSIFIED	18. SECURITY CLASSIFICATION OF THIS PAGE UNCLASSIFIED	19. SECURITY CLASSIFICATION OF ABSTRACT UNCLASSIFIED	20. LIMITATION OF ABSTRACT UL	