



Development of Smart Meter to Monitor Real Time Energy Consumption for Sustainability

Alan P. Nebrida^{1*}, Chavelita D. Amador¹, Clyed M. Madiam¹, Glenn John S. Ranche¹

¹College of Engineering, Electrical Engineering Department,
Nueva Vizcaya State University, Bambang, Nueva Vizcaya, PHILIPPINES

*Corresponding Author

DOI: <https://doi.org/10.30880/ijscet.2023.14.04.003>

Received 20 November 2022; Accepted 31 May 2023; Available online 15 October 2023

Abstract: This study constructed a Smart Energy Meter where energy consumption can be viewed by the consumers based on real time using data from smart meters. Its goals are to increase productivity, make readings more precise, and take less time to determine an individual residence's energy consumption. The device is made up of the PZEM-016 AC Energy Meter, RS-485 UART Serial Converter, NodeMCU ESP8266, Blynk IoT Application, Arduino Uno R3, and LCD Arduino Keypad Module Shield Board. The PZEM-016 is used in this smart energy meter to measure voltage, current, power, frequency, power factor, and energy consumption. Because it lacks its own display, an RS-485 was utilized to communicate with the NodeMCU and Arduino Uno. The NodeMCU sends the parameters to Blynk IoT App as long as it is connected to a fixed mobile WiFi. The Blynk will then display a real-time measurement of the parameters. The Arduino Uno is programmed to display the parameters to the LCD Keypad Module. The device was tested in an actual household. The researchers conducted 48-hour observation on the household where the energy displayed in the Blynk IoT App and the LCD display matches at approximately 9 kWh which is the same as the actual energy meter of the house that is 9kWh. The device is also tested on different appliances which resulted in the same energy consumption in both the Blynk IoT App and LCD display with the ratings of the appliances. The device was found functional.

Keywords: Smart Energy Meter, IoT application, AC energy meter, microcontrollers, Blynk cloud

1. Introduction

One of mankind's greatest triumphs has been the discovery of electricity, which has become one of the most essential prerequisites for pleasant life. Electricity is now employed in almost every area of human life, including communication, transportation, health, mining, agriculture, industry, and commerce. Electricity is mostly used in industries to power large machinery that produce items. Cooking, watching television, air conditioning, lighting, and space heating are just a few of the commercial and domestic uses. Electricity is essential not only for social growth and human wellbeing, but also for the total development of our country. In most parts of the world, electricity is generated and supplied to consumers by electricity companies. These companies in return charge electricity consumers an equivalent amount of money based on their consumption. The energy meter was introduced to help electricity companies measure the amount of electrical energy consumed by customers. Methods used by energy companies for metering and billing of power (electricity consumed) have seen immense transformation over the years.

Energy dispersion and rational usage are important requirements for a tolerable life. The current method of Energy charging has a number of drawbacks, including excessive labor utilization, human errors, and customers' inability to

monitor their energy usage, as well as an increase in the overall cost of the system. Basic energy meters are divided into two categories: electromechanical energy meters and electronic energy meters. The electromechanical induction Watt-Hour meter is the most often used energy meter. The electromechanical induction meter measures the rotation of an electrically conductive and non-magnetic metal spinning at a speed proportionate to the power travelling through it. The power usage is related to the number of rotations or revolutions. An energy meter displays the amount of energy utilized on a Liquid Crystal Display (LCD) or Light Emitting Diode (LED) display, and some meters may broadcast data to remote locations. Many inaccuracies in traditional billing are attributable to human error. Time-consuming approach, manual meter reading always contains a potential for human mistakes. It includes a lot of power theft and corruption; increased manpower needs are some of the frequent problems that are studied from traditional billing.

These energy meters are crucial for determining how much electricity is consumed residences. With the advent of technology, these energy meters have been gradually improving to address the difficulties that conventional meters have caused. The issue is when residents are oblivious to their everyday consumption, consumers will not know how much energy the various appliances consume until they receive the monthly bills. This study constructed a Smart Energy Meter where energy consumption can be viewed by the consumers based on real-time using data from smart meters. Its goals are to increase productivity, make readings more precise, and take less time to determine an individual residence's energy consumption, sustain that consumption, and/or reduce that consumption.

The general objective of the study is to construct a smart energy meter to simplify the monitoring of energy consumption. To be specific, this study aims to: (i) design a smart energy meter that can be monitored in Real-Time; (ii) create a program using NodeMCU ESP8266 and Arduino Uno to run the smart energy meter; (iii) test the functionality of the smart energy meter.

The significance of this study is to offer a simple method for reading energy consumption meters so that households may promptly monitor their usage. It is significant for the consumers as they can monitor their consumption in real-time thus, they can track their consumption and identify energy waste points and control spending on power consumption. Additionally, it is designed to make it easier for the utility reader to produce quick and precise meter readings while also introducing them to the benefits of adopting smart energy meters.

The study focuses on the design and construction of a Smart Energy Meter. This was designed to monitor the real-time energy consumed in the household via the Blynk IoT (Internet of Things) Application in an android phone at the same time the real-time energy usage will also appear in an LCD display incorporated in the Smart Energy Meter. The study will use the PZEM-016 AC Energy Meter to measure the voltage, current, active power, energy, frequency, and power factor. The PZEM-016 module is without a display function, therefore, the data is sent through RS-485 UART (Universal Asynchronous Receiver-Transmitter) Serial Converter. The RS-485 converts the data into digital data and can communicate with the NodeMCU (Node Microcontroller Unit) ESP8266 for data transmission. When the NodeMCU ESP8266 is connected to Wi-Fi the consumer can monitor real-time feedback of the smart energy meter through the Blynk IoT Application. Another RS-485 UART Serial Converter is used to communicate the PZEM-016 to an Arduino Uno which is interfaced to an LCD Arduino Keypad Module Shield Board to display the parameters that the PZEM-016 measured.

2. Methodology

2.1 Conceptual Framework

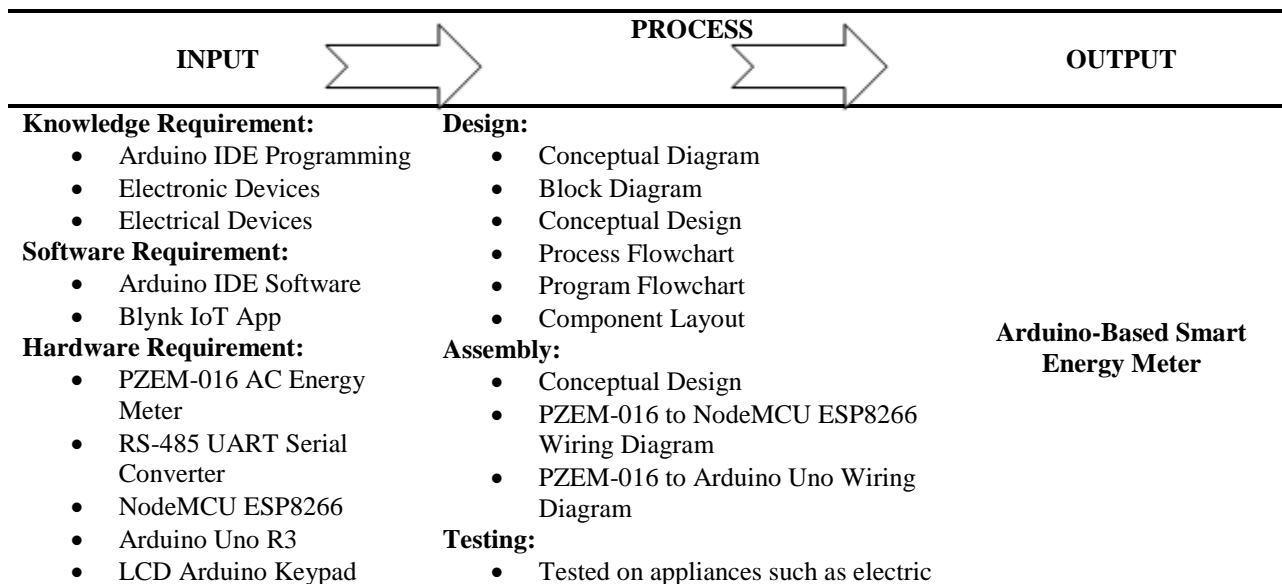

Module Shield Board	fan, refrigerator and water pump
	<ul style="list-style-type: none"> • Tested on an actual household

Fig. 1 - Conceptual framework

The conceptual framework consists of input, process, and output. The inputs are the following knowledge, software and hardware requirements. The knowledge requirement is Arduino IDE programming while the software requirement is Arduino IDE software and Blynk IoT Application. The hardware requirement composes of PZEM-016 AC Energy Meter, RS-485 UART Serial Converter, NodeMCU ESP8266, Arduino Uno R3, and LCD Arduino Keypad Module Shield Board. The process consists of the following design, assembly, and testing. The design consists of the Conceptual Diagram, Block Diagram, Conceptual Diagram, Process Flowchart, Program Flowchart and Component Layout. The assembly is the Conceptual design, PZEM-016 to NodeMCU ESP8266 Wiring Diagram and PZEM-016 to Arduino Uno Wiring Diagram. The testing consists of appliances such as electric fans, refrigerators, and water pumps and on an actual household. The output is the Arduino Based Smart Energy Meter.

2.2 Conceptual Diagram

Figure 2 shows the conceptual diagram of the smart energy meter. This smart energy meter uses the PZEM-016 AC Energy Meter to measure the voltage, current, active power, frequency, power factor, and energy consumption.

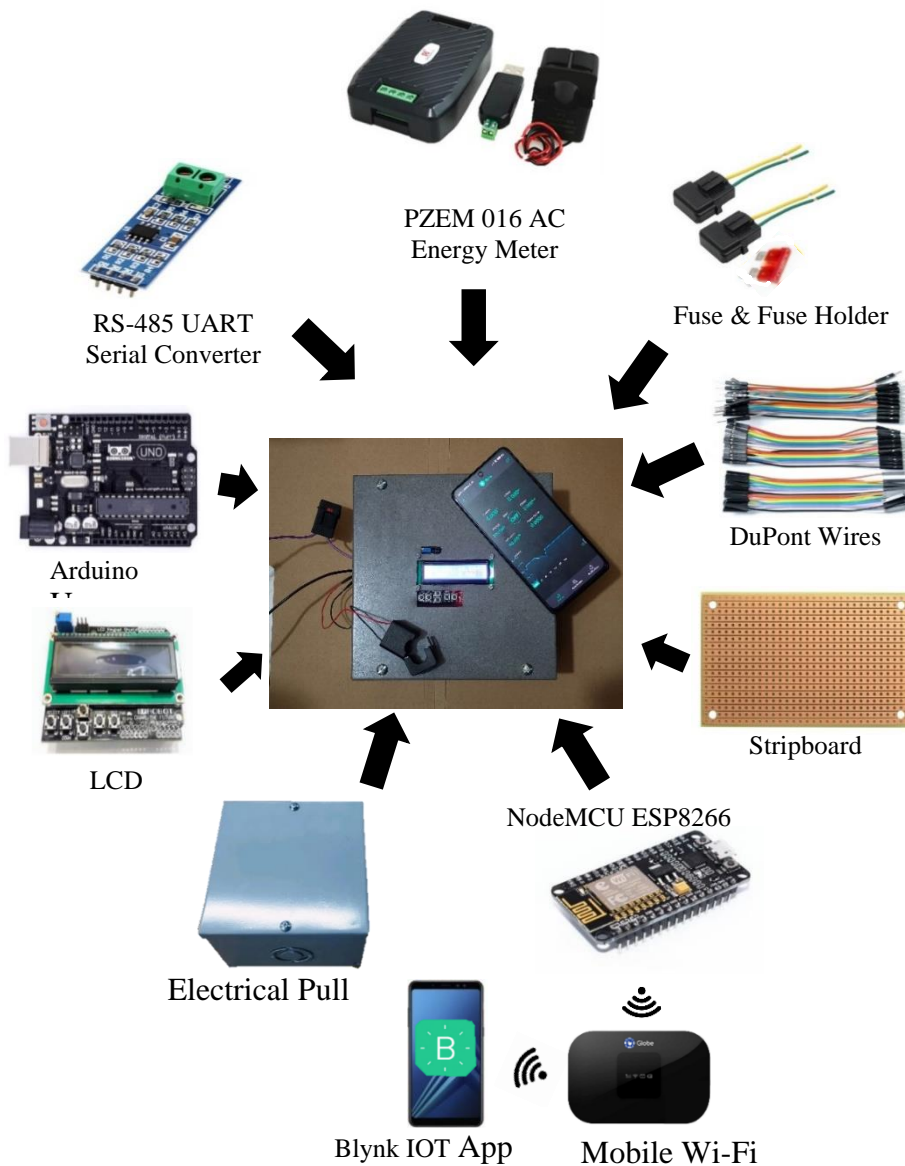

Fig. 2 - Conceptual diagram

As the PZEM-016 AC Energy Meter does not have its own display capability the RS-485 UART Serial Converter was used to convert the data from the PZEM-016 into digital data and transmit it to the NodeMCU ESP8266 which is programmed to read and transmit the measured data to the Blynk Cloud from which the Blynk IoT Application in an android phone will display the voltage, current, active power, frequency, power factor, and energy consumption in rereal-time. Another RS-485 UART Serial Converter was used to convert the data into digital data and transmit it to an Arduino Uno which is programmed to read the data and to display the parameters in real-time in an LCD Arduino Keypad Module Shield Board

2.3 Block Diagram

A block diagram of the smart energy system shown in Figure 3 was conceptualized. When the PZEM 016 is connected to the circuit it will start to measure the voltage, current, power, frequency, power factor, and energy usage of the circuit. The 5V DC output of the PZEM 016 AC Energy Meter was used to power the system. The RS-485 UART Serial Converter is used to communicate the data to the microprocessors of the system. As the system started to work the NodeMCU ESP8266, through its programming, will send the parameters measured to Blynk IoT App. As long as the mobile WiFi that the NodeMCU ESP8266 is programmed to connect is open it can upload the parameters to the Blynk IoT App. The Blynk IoT App should also be connected to a WiFi for it to receive the data. Additionally, the Arduino Uno will also start its program to display the parameters in the LCD Arduino Keypad Module. Everything that is measured by the PZEM 016 can be viewed in real time either in the LCD Arduino Keypad Module or the Blynk IoT App in an android phone. The users can reset the energy usage back to zero through the reset button in the Blynk IoT App or through the LCD Arduino Keypad Module following the programmed steps of the Arduino Uno.

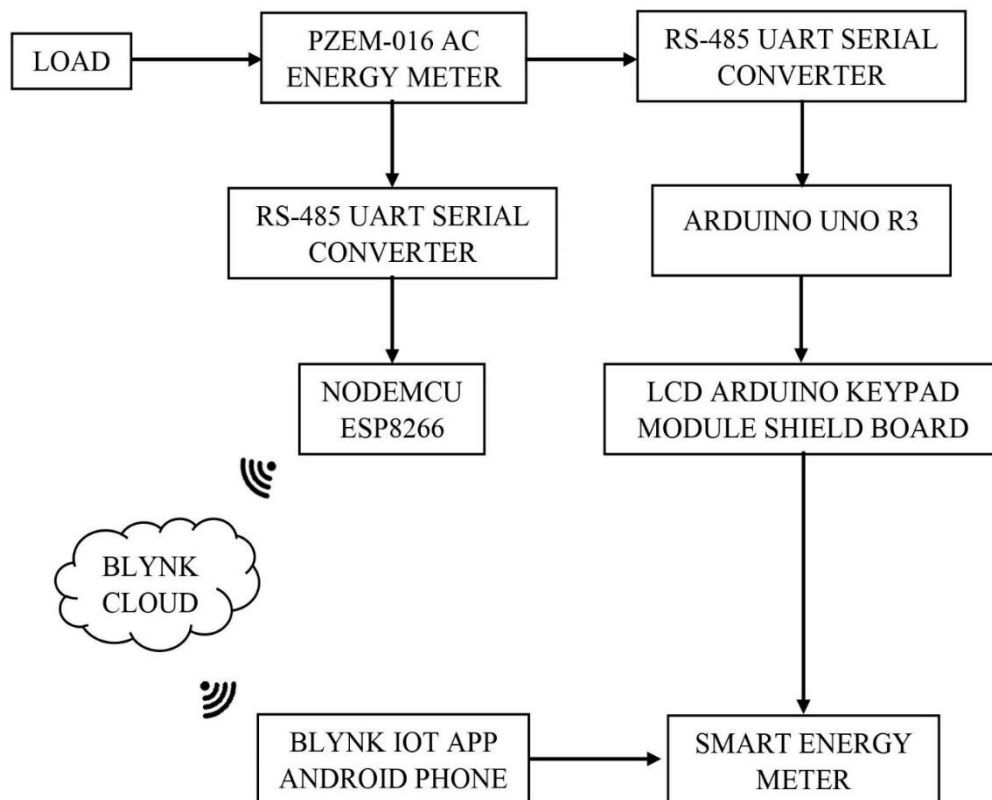

Fig. 3 - Block diagram

2.4 Program Flowchart

The program flowchart shown in Figure 4 was conceptualized. The system of the Smart Energy Meter will start to boot up. The PZEM-016 AC Energy Meter will then start the measurement of the parameters from the household's circuit, which are the voltage, current, active power, energy, frequency, and power factor. The PZEM-016 will then transmit the data. If the Blynk IoT Application is online, it will display the parameters transmitted by the NodeMCU in the Blynk Cloud which is the real-time energy consumption of the household. Simultaneously, the Arduino Uno R3 receives data and displays it on the LCD Arduino Keypad Module in real-time. Both programming of the NodeMCU

and Arduino Uno works simultaneously and will fluctuate the parameters every second in their display making it a real-time measurement.

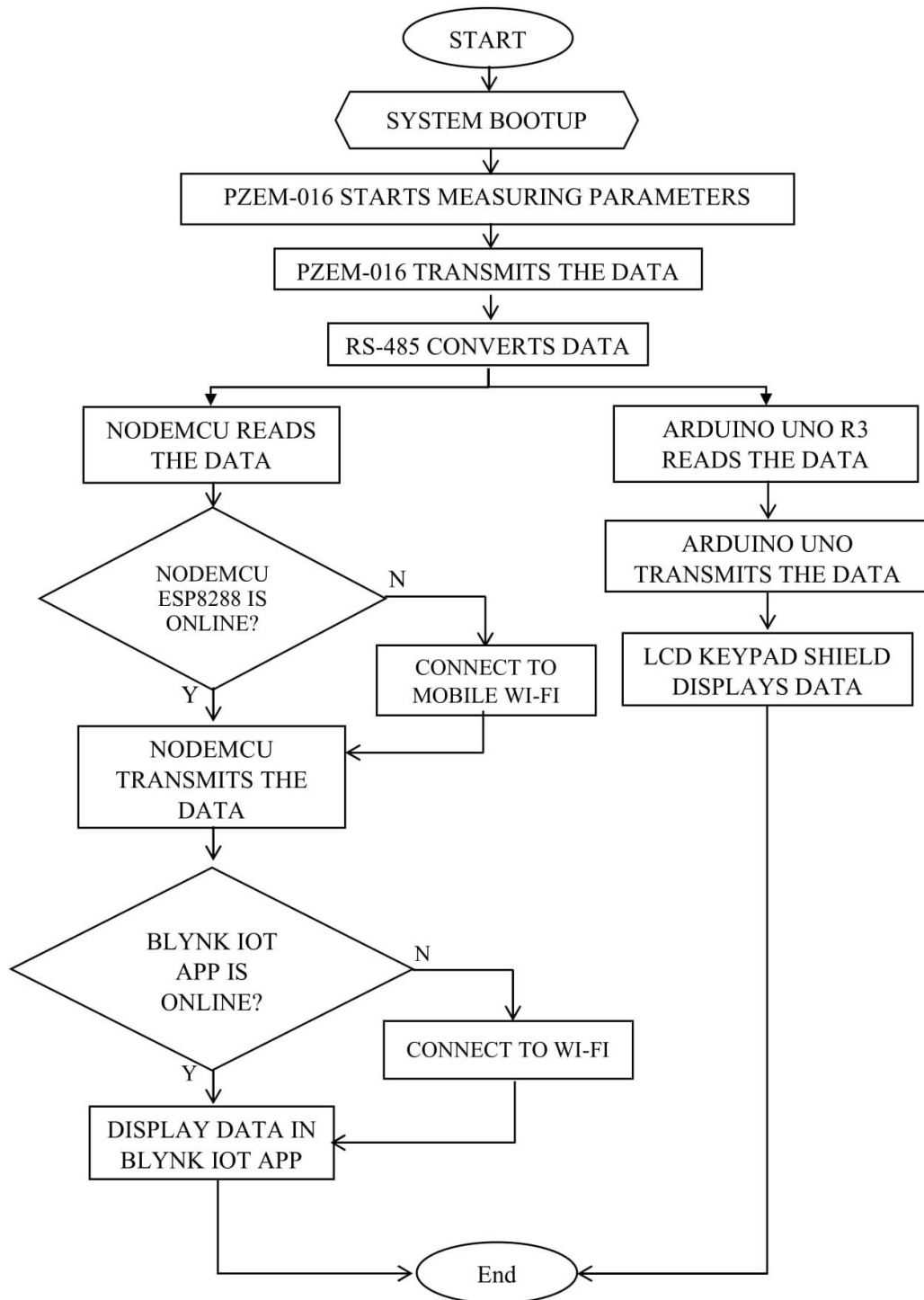

Fig. 4 - Program flowchart

2.5 Component Layout

Figure 5 shows the connection of the smart energy metering device. The PZEM-016 AC Energy Meter measures the voltage, current, active power, frequency, power factor, and energy of the circuit. There are two RS-485 UART Serial Converters used in the system to convert the data into digital data and transmit to the two microprocessors used to display the parameters measured. The NodeMCU ESP8266 is programmed to connect to a fixed Mobile WiFi network, which is provided in this study, thus it can connect to Blynk IoT Application via Virtual Pins which is also coded in the NodeMCU ESP8266. The Blynk IoT Application can then display the parameters measured by the PZEM-

016 AC Energy Meter. Simultaneously, the microprocessor Arduino Uno R3 is also programmed to display the measure parameters to an LCD using the LCD Arduino Keypad Module Shield Board that is directly connected over it.

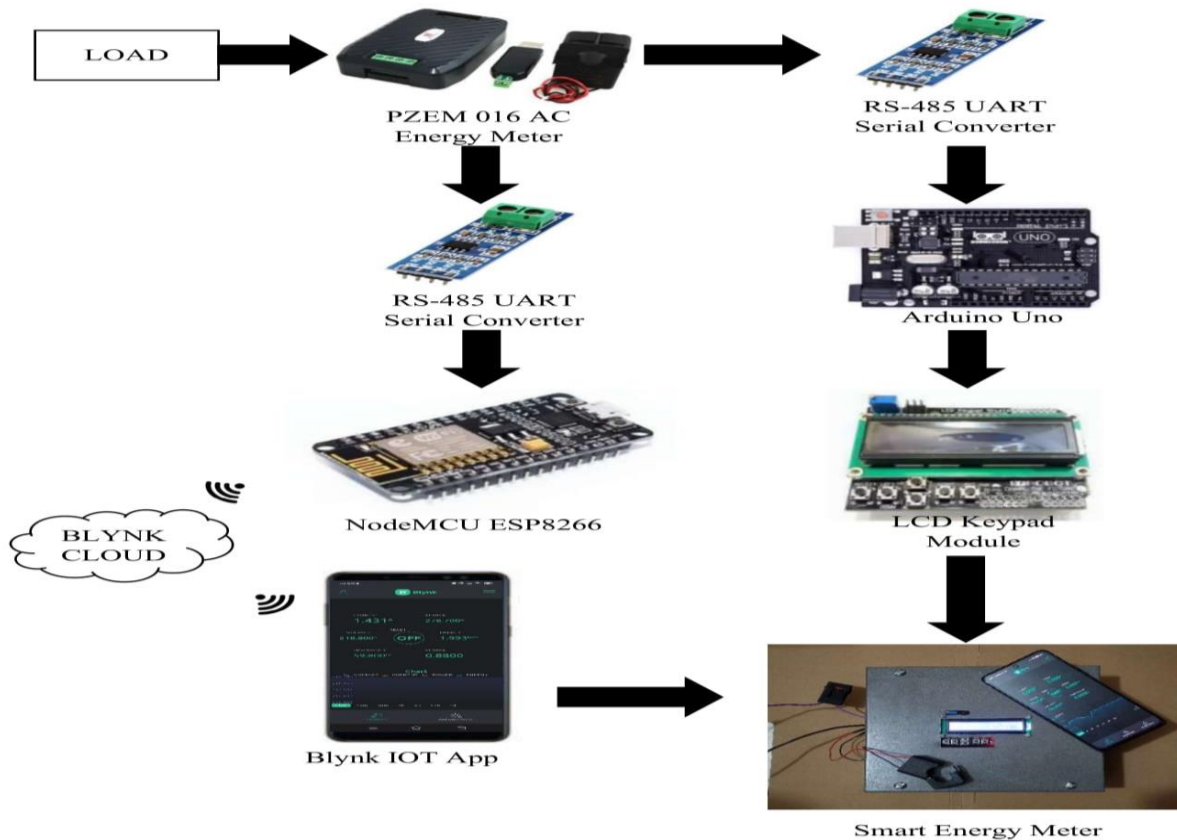

Fig. 5 - Component layout

2.6 Wiring Diagram - PZEM-016 to NodeMCU ESP8266

Figure 6 shows the connection of the wiring diagram from the PZEM-016 AC Energy Meter to NodeMCU ESP8266. The current transformer coil sensor of the PZEM-016 is clipped in the live wire of the circuit. Two wires are then connected to the main circuit where one wire is connected to the live wire and the other is connected to the neutral. Once the wires are connected the PZEM-016 will start measuring the data from the circuit. To transmit data, the A terminal of the meter is connected to the A pin of the RS-485 UART Serial Converter. The B terminal of the meter is connected to the B pin of the RS-485. To provide power to the RS-485, the 5V positive of the meter is connected to the Vcc pin of the RS-485 whilst the Gnd pin is connected to the 5V ground of the meter. The RS-485 will convert the data into digital data and will transmit it to the NodeMCU where the Receiver Out (RO) pin of the RS-485 is connected to the Digital 5 (D5) pin of the NodeMCU. The Data In (DI) pin of the RS-485 is connected to the Digital 6 (D6) pin of the NodeMCU. The Receiver Enabled (RE) pin of the RS-485 is connected to the Digital 2 (D2) pin of the NodeMCU. and, the Data Enabled (DE) pin of the RS-485 is connected to the Digital 1 (D1) pin of the NodeMCU. To provide power to the NodeMCU, the 5V positive of the meter is connected to the 3V pin of the NodeMCU whilst the Gnd pin is connected to the 5V ground of the meter.

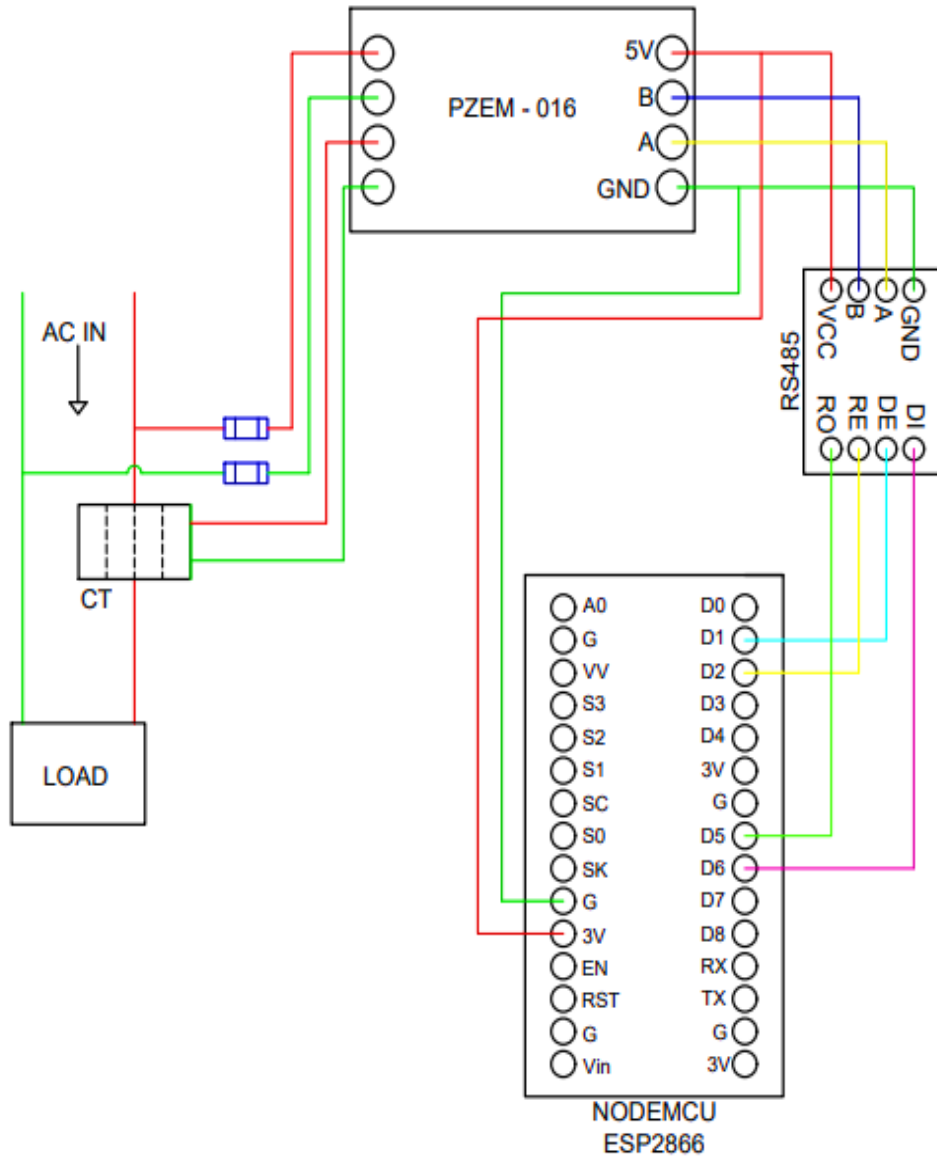

Fig. 6 - PZEM-016 to NodeMCU ESP8266 Wiring Diagram

2.7 PZEM-016 AC Energy Meter to Arduino Uno

Figure 7 shows the connection of the wiring diagram from the PZEM-016 AC Energy Meter to Arduino Uno. The PZEM-016's current transformer coil sensor is hooked into the live wire of the circuit. Two wires are then connected to the main circuit where one wire is connected to the live wire and the other is connected to the neutral. The PZEM-016 will begin measuring the data from the circuit as soon as the wires are connected. The RS-485 UART Serial Converter's A pin is linked to the A terminal of the meter to transfer data. The B pin of the RS-485 is connected to the B terminal of the meter. The Gnd pin of the RS-485 is connected to the 5V ground of the meter. The RS-485 will convert the data into digital data and will transmit it to the Arduino Uno where the Receiver Out (RO) pin of the RS-485 is connected to the Digital 0 (D0) pin of the Arduino Uno. The Data In (DI) pin of the RS-485 is connected to the Digital 1 (D1) pin of the Arduino Uno. The Receiver Enabled (RE) pin of the RS-485 is connected to the Digital 2 (D2) pin of the Arduino Uno. To provide power to the Arduino Uno, the 5V positive of the meter is connected to the 5V pin of the Arduino Uno whilst the Gnd pin is connected to the 5V ground of the meter. The LCD Arduino Keypad Module Shield Board is attached above the Arduino Uno connecting all the LCD Arduino Keypad Module Shield Board pins to the corresponding pins of the Arduino Uno.

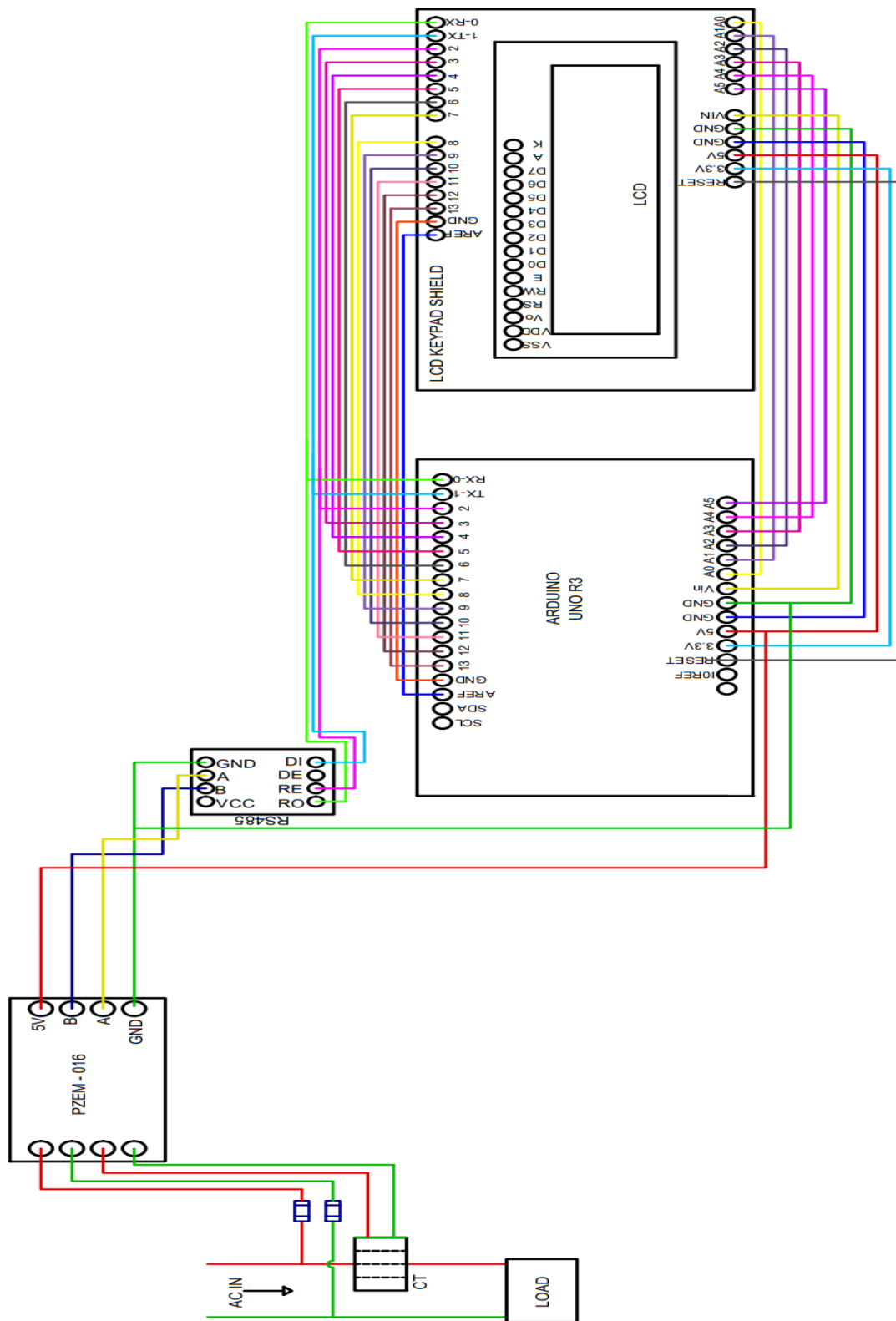

Fig. 7 - PZEM-016 to Arduino Uno Wiring Diagram

2.8 Bill of Materials

Table 1 shows the bill of materials of the prototype of the Smart Energy Meter. The total amount calculated was 4,881.00 Philippine pesos. This includes all the parts needed to build the prototype device.

Table 1 - Bill of materials

Item No.	Materials	Description	Quantity	Unit	Unit Price (₱)	Total (₱)
1	Microcontroller	Arduino Uno R3	1	pc	1,380.00	1,380.00
2	TTL Signal Converter	RS485 UART Serial Converter	2	pcs	98.00	196.00
3	Microcontroller	NodeMCU ESP8266	1	pc	245.00	245.00
4	LCD Arduino Keypad Module Shield Board	2x16 Display, 6 Keys	1	pc	250.00	250.00
5	PCB Stripboard	14.5cm x 6.5cm	1	pc	45.00	45.00
6	PZEM – 016 AC Energy Meter	AC80~260V, 0~100A	1	pc	750.00	750.00
7	Blade Type Fuse	10 Amp	1	pc	10.00	10.00
8	Fuse Holder	Single Fuse Holder	1	pc	35.00	35.00
9	DuPont wires	28 AWG	1	set	50.00	50.00
10	Mobile Wi-Fi	Globe LTE	1	pc	900.00	900.00
11	THHN wire	2.0 mm ² Stranded Wire	2	m	20.00	40.00
12	Wire	22AWG	8	m	5.00	40.00
15	Electrical Pull Box	(8x8x4) in	1	pc	600.00	600.00
16	Blynk IoT App	Subscription	1	month	340.00	340.00
Total:						₱4,881.00

3. Results and Discussion

3.1 48 Hours Test Data for Household (Blynk IoT App)

Table 2 shows the reading of the smart energy meter in the Blynk IoT App; the second row shows the reading during the installation of the devices. It shows the values of the voltage, current, power, energy, frequency, and power factor are 220.9 V, 0.796 A, 162.1 W, 0.007 kWh, 60 Hz, and 0.94, respectively. On July 24, the voltage is 228.3 V at 5:00 am while at 11:00 am the voltage was 217.7 V, and then at 11:00 pm, the voltage strikes 221.8 V.

Table 2 - 48 Hours Test Data for Household (Blynk IoT App)

DATE	TIME	Voltage (V)	Current (A)	Power (W)	Energy (kWh)	Frequency (Hz)	Power Factor
7/23/2022	11:00 PM	220.900	0.796	162.10	0.007	60.000	0.940
	5:00 AM	228.300	0.574	125.30	0.885	60.100	0.980
7/24/2022	11:00 AM	217.700	0.313	64.40	1.619	60.000	0.950
	5:00 PM				OFFLINE		
	11:00 PM	221.800	0.896	186.10	4.355	60.200	0.940
	5:00 AM	225.800	1.361	275.30	5.560	59.900	0.900
7/25/2022	11:00 AM	216.400	0.486	98.70	6.863	60.000	0.940
	5:00 PM	224.000	0.334	62.10	7.875	60.200	0.840
	11:00 PM	222.610	0.854	171.72	8.995	59.949	0.904

The current is 0.574 A at 5:00 am then drops to 0.313 A at 11:00 pm and rises to 0.896 A at 11:00 pm. The power at 5:00 am is 125.3 W while at 11:00 am the power is 64.4 W then at 11:00 pm, it rises to 186.1 W. The energy consumed at 5 am is 0.885 kWh while on 11:00 am it is 1.619 kWh and at 11:00 pm the energy consumed is 4.355 kWh. The frequency is approximately equal to 60 Hz at 5:00 am, 11:00 am and 11:00 pm. The frequency is 0.98, 0.95 and 0.94, at 5:00 am, 11:00 am, and 11:00 pm, respectively. At 12 noon until 5 pm the app is offline due to the network problem. On the second day, July 25, the measured voltage at 5:00 am is 225.8 V then drops to 216.4 V at 11:00 am. Then suddenly strikes to 224 V at 5:00 pm then drops to 222.61 V at 11:00 pm. The current at 5:00 am is 1.361 A then drops to 0.486 A at 11:00 am. At 5:00 pm the current is 0.334 A and at 11:00 pm it strikes at 0.854 A. At 5:00 am the power is 275.3 W while at 11:00 am the power measured is 98.7 W. The measured power at 5:00 pm is 62.1 W then at

11:00 pm it is 171.729 W. The frequency is approximately equal to 60 Hz. The power factor for 5:00 am, 11:00 am, 5:00 pm and 11:00 pm are 0.90, 0.94, 0.84 and 0.904, respectively. The total energy consumed for 48 hours is 8.995 kWh.

3.2 48 Hours Test Data for Household (LCD)

Table 3 shows the measured data on the LCD keypad module, on the top row the reading for the voltage, current, power, energy, frequency and power factor is 220.4 V, 0.737 A, 153.3 W, 0 kWh, 60 Hz and 0.94, respectively. On the first day, July 24, the voltage is 227.8 V and at 11:00 am the voltage is 217.1 V then rises to 218.2 V at 5:00 pm and strikes to 221.3 V at 11:00 pm.

Table 3 - 48 Hours Test Data for Household (LCD)

Day	Time	Voltage (V)	Current (A)	Power (W)	Energy (Wh)	Frequency (Hz)	Power Factor
7/23/2022	11:00 PM	220.400	0.737	153.300	0.000	60.000	0.940
7/24/2022	5:00 AM	227.800	0.575	126.000	886.000	60.000	0.970
	11:00 AM	217.100	0.311	63.700	1619.000	59.900	0.950
	5:00 PM	218.200	0.485	105.800	2556.000	60.000	0.950
	11:00 PM	221.300	0.896	186.100	4355.000	60.100	0.940
7/25/2022	5:00 AM	225.300	1.360	274.400	5557.000	60.000	0.900
	11:00 AM	215.900	0.484	97.900	6862.000	59.900	0.940
	5:00 PM	223.700	0.331	61.900	7875.000	60.100	0.840
	11:00 PM	222.200	0.844	170.300	8994.000	60.000	0.910

The current measured at 5:00 am is 0.575 A while at 11:00 am it is 0.311 A, and it is 0.485 A at 5:00 pm while 0.896 A at 11:00 pm. The power is 126 W at 5:00 am then 63.7 W at 11:00 am, then rises to 105.8 W at 5:00 pm and continuously rises to 186.1 W at 11:00 pm. The measured frequency is approximately equal to 60 Hz. The power factor for 5:00 am, 11:00 am, 5:00 pm and 11:00 pm is 0.97, 0.95, 0.95, and 0.94, respectively. On the second day, July 25, the voltage at 5:00 am is 225.3 V then drops to 215.9 V at 11:00. At 5:00 pm the voltage is 223.7 V then drops to 222.2 V at 11:00 pm. The current at 5:00 am is 1.360 A then at 11:00 am it is 0.484 A. At 5:00 pm the current is 0.331 A then at 11:00 pm it is 0.844 A. The power measured by the smart energy meter is 274.4 W at 5:00 am, then 97.9 W at 11:00 am. At 5:00 pm the power is 61.9 W then at 11:00 pm it is 170.3 W. The frequency is approximately equal to 60 Hz. The power factor for 5:00 am, 11:00 am, 5:00 pm and 11:00 pm is 0.90, 0.94, 0.84 and 0.91, respectively. The total energy consumed for 48 hours is 8994 Wh.

4. Conclusions

1. The researchers were able to design an Arduino Based Smart Energy Meter that can be monitored in real-time.
2. The researchers were able to develop a program that successfully displays the measured data in two modes, through Blynk IoT Application in an Android phone and LCD Keypad Module.
3. The system prototype was tested and was functional, the values measured and displayed in both the Blynk IoT Application and LCD Keypad Module are the same to the kilo-watt hour meter of the household.

Acknowledgement

There are several people for whom without them this thesis would not have been possibly written, and to whom the researchers are extremely grateful.

The researchers would first like to express their sincere gratitude to the administration of Nueva Vizcaya State University headed by RUTH R. PADILLA, Officer-in-Charge, Office of the University President.

ENGR. CHERRY D. QUIDIT, the Department Chair of the Bachelor of Science in Electrical Engineering, for her tolerance, passion, and extensive knowledge. Her lessons shared are very important to researchers throughout their studies and writing papers.

To the members of the Oral Examination Committee, **ENGR. JEMIMAH P. NATIVIDAD**, **ENGR. DHOM RYAN S. MILLARES**, **ENGR. SIDNEY LEE V. CARO**, and **ENGR. RYAN VICTOR BAUTISTA**, who shared their time and expertise in critiquing and sharing additional inputs in making this study a success.

To the RESEARCHERS' PARENTS, FRIENDS, AND LOVED ONES, for their unending support and with whom they shared their lives, whether joyful or sorrowful, their heartfelt gratitude for the motivations through moral and financial support, and love; and

Above all, deepest thanks to the Almighty Father who sustained them with wisdom, knowledge and understanding, good health, and strength, who poured encouragement through His Word which guided us for the completion of this research.

References

- Alam, S. U., Ahmed, R., Imam, S., Farshid, M., Hossain, A., & Islam, A. (2019). Design and Implementation of Website based Energy Consumption Monitoring and Controlling. *2019 International Conference on Computer Communication and Informatics (ICCCI)*, (pp. 1-7). doi: 10.1109/ICCCI.2019.882197
- Beckel, C., Sadamori, L., Staake, T., & Santini, S. (2014). Revealing household characteristics from smart meter data. *Energy*, 78, 397-410. <https://doi.org/10.1016/j.energy.2014.10.025>
- Castañó Jaramillo, Natalia, Franco Cardona, Carlos Jaime, & Velásquez Henao, Juan David. (2014). Smart Meters Adoption: Recent Advances and Future Trends. *Dyna*, 81(183), 221-230. <https://Doi.Org/10.15446/Dyna.V81n183.38148>
- Dewangan, et.al (2019). SmartEnergy Meter Monitoring based on Arduino Uno and GSM. *International Journal for Research in Applied Science & Engineering Technology (IJRASET)*, 1-8. doi: 10.22214/ijraset.2019.8122
- Faraj & Marouki (2020). Printed Circuit Board Manufacturing. *Computer Techniques Engineering Department*. Pp. 1-10.
- Idoko, E. C., Oraedu, C., Ugwuanyi, C. C., & Ukenna, S. I. (2021). Determinants of Smart Meter on Sustainable Energy Consumption Behavior: A Developing Country Perspective. *SAGE Open*, 11(3). <https://doi.org/10.1177/21582440211032193>
- Gunadi, I., Syaputra, I., & Susanto, R. (2020). Smart Electric Billing System with RFID. *IOP Conference Series: Earth and Environmental Science* 794 012129. doi: 10.1088/1755-1315/794/1/012129
- J. Zheng, D. W. Gao and L. Lin, "Smart Meters in Smart Grid: An Overview," 2013 IEEE Green Technologies Conference (GreenTech), Denver, CO, USA, 2013, pp. 57-64, doi: 10.1109/GreenTech.2013.17.
- Kabalci, Y. (2016). A survey on smart metering and smart grid communication. *Renewable and Sustainable Energy Reviews*, 57, 302-318. <https://doi.org/10.1016/j.rser.2015.12.114>
- Knayer, T., & Kryvinska, N. (2022). An analysis of smart meter technologies for efficient energy management in households and organizations. *Energy Reports*, 8, 4022-4040. <https://doi.org/10.1016/j.egy.2022.03.041>
- Kowsalya, et.al (2019). Intelligent Energy Meter using GSM Modem with Arduino. *International Journal of Innovative Technology and Exploring Engineering (IJITEE)*, 161-163.
- M. R. Asghar, G. Dán, D. Miorandi and I. Chlamtac. "Smart Meter Data Privacy: A Survey," in IEEE Communications Surveys & Tutorials, vol. 19, no. 4, pp. 2820-2835, Fourthquarter 2017, doi: 10.1109/COMST.2017.2720195.
- Media's, Syufrijal and Rif'an, (2019). Internet of Things (IoT): BLYNK Framework for Smart Home. 3rd UNJ International Conference on Technical and Vocational Education and Training, 579-586. doi: 10.18502/kss.v3i12.4128
- Nguyen T.T, Nguyen Q.N & Nguyen X.H, (2021). On an application of node MCU Esp8266 in opening and closing the laboratory door-online practice. *Global Journal of Engineering and Technology Advances*, 87-91. doi: 10.30574/gjeta.2021.9.3.0174
- Othman, A., & Zakaria, N. H. (2020). Energy Meter based Wireless Monitoring System Using Blynk Application via smartphone. 2020 IEEE 2nd International Conference on Artificial Intelligence in Engineering and Technology (ICALET). doi: 10.1109/iicalet49801.2020.9257827
- Patel, H. K., Mody, T., & Goyal, A. (2019). Arduino Based Smart Energy Meter using GSM. *2019 4th International Conference on Internet of Things: Smart Innovation and Usages (IoT-SIU)*. Pp. 1-6. Doi: 10.1109/iot-siu.2019.8777490
- Pereira, L., Costa, D., & Ribeiro, M. (2022). A residential labeled dataset for smart meter data analytics. *Scientific Data*, 9(1), 1-11. <https://doi.org/10.1038/s41597-022-01252-2>
- Rind, Y. M., Raza, M. H., Zubair, M., Mehmood, M. Q., & Massoud, Y. (2023). Smart Energy Meters for Smart Grids, an Internet of Things Perspective. *Energies*, 16(4), 1974. <https://doi.org/10.3390/en16041974>
- Srivatchan, N.S., & Rangarajan, P. (2018). A Novel Low-Cost Smart Energy Meter Based on IoT for Developing Countries' Micro Grids. *Concurrency and Computation: Practice and Experience*, e5042. Doi: 10.1002/cpe.5042
- Vadda, & Seelam. (2013). Smart Metering for Smart Electricity Consumption. *School of Computing Blekinge Institute of Technology*, 1-71.
- Y. Wang, Q. Chen, T. Hong and C. Kang, "Review of Smart Meter Data Analytics: Applications, Methodologies, and Challenges," in IEEE Transactions on Smart Grid, vol. 10, no. 3, pp. 3125-3148, May 2019, doi: 10.1109/TSG.2018.2818167.

Yoeseph, N. M., Safi'ie, M. A., & Purnomo, F. A. (2019). Smart Energy Meter based on Arduino and Internet of Things. *IOP Conference Series: Materials Science and Engineering*, 578, 012085. Doi: 10.1088/1757-899x/578/1/012085