

A GENETIC AND DEVELOPMENTAL ANALYSIS OF DNASE-1,
AN ACID DEOXYRIBONUCLEASE IN DROSOPHILA MELANOGASTER

A Thesis

Presented to the Faculty of the Graduate School
in Partial Fulfillment for the Degree of
Doctor of Philosophy

by

Charles Roger Detwiler

May, 1979

BIOGRAPHICAL SKETCH

Charles R. Detwiler was born on December 15, 1950 in Norristown, Pennsylvania. He attended Collegeville-Trappe High School in Trappe, Pennsylvania from 1964 to 1968; Houghton College in Houghton, New York from 1968 to 1972 (B.S., Zoology); Bucknell University in Lewisburg, Pennsylvania from 1972 to 1974 (M.S., Biology); and Cornell University in Ithaca, New York from 1974 to 1979 (Ph.D., 1979). At Cornell he was a National Institutes of Health Genetics Trainee.

He is a member of the Genetics Society of America, the American Scientific Affiliation, and of Phi Sigma, the National Honorary Biology Society.

To the Designer of the fly

ACKNOWLEDGMENTS

I would like to thank all my friends who by their moral support or careful critical attention contributed to the completion of this work. First, I would like to thank my major professor, Dr. Ross MacIntyre, for his patience, generosity, and valuable ideas. I would like to thank Dr. Richard Halberg and Dr. Bruce Wallace for their helpful comments and criticisms with regard to the thesis project. I would like to thank Margaret Dean for tireless reassurances and valuable technical assistance especially at the beginning. Lastly, Beverly my wife is acknowledged. It would be absurd to "thank" her. Her patience and devotion have served both in bringing these pages together, and in keeping two people together in one beautiful relationship.

TABLE OF CONTENTS

Introduction Page 1

Chapter 1. A Genetic Localization and Production
of "Null" Alleles of the Structural Gene
for the Major Soluble Acid Deoxyribo-
nuclease of Drosophila melanogaster. Page 2

Chapter 2. A Subcellular Localization of the Gene
Product of the DNase-1 Locus in Droso-
phila melanogaster. Page 56

Chapter 3. A Developmental Analysis of the Expression
of Wild Type and Null Alleles of the
DNase-1 Locus of Drosophila melanogaster. Page 87

Appendix. Partial Purification of DNase-1 from
Drosophila melanogaster. Page 113

LIST OF TABLES

<u>Chapter 1</u>	<u>Page</u>
Table 1.1 <u>Drosophila melanogaster</u> stocks used in cytological localization of <u>DNase-1</u> .	20
Table 1.2 Expected phenotype and DNase-1 genotype of progeny of crosses shown in Figure 1.4.	26
Table 1.3 <u>DNase-1</u> activity mutants.	38
Table 1.4 Acid DNase activities of null stocks.	41
 <u>Chapter 2</u>	
Table 2.1 Mean relative activities of acid DNase, acid phosphatase and α -GPDH in three sub- cellular fractions of embryonic cells of <u>Drosophila melanogaster</u> .	66
Table 2.2 Mean relative activities of DNase-1 and acid phosphatase-1 in subcellular fractions of embryonic cells from two strains of <u>Drosophila melanogaster</u> .	72
 <u>Chapter 3</u>	
Table 3.1 Time in days required to reach various developmental stages for the individuals from several strains of <u>Drosophila melanogaster</u> .	97
Table 3.2 Oviposition rates for three strains of <u>Droso-</u> <u>phila melanogaster</u> .	104
 <u>Appendix</u>	
Table 4.1 Partial purification of acid DNase from <u>Drosophila melanogaster</u> .	120

LIST OF FIGURES

<u>Chapter 1</u>	<u>Page</u>
Figure 1.1	10
Figure 1.2	12
Figure 1.3	18
Figure 1.4	21
Figure 1.5	23
Figure 1.6	27
Figure 1.7	30
Figure 1.8	33
Figure 1.9	36
Figure 1.10	45
 <u>Chapter 2</u>	
Figure 2.1	61
Figure 2.2	68

<u>Chapter 2</u> , continued	<u>Page</u>
Figure 2.3 DNase-1 and acid phosphatase-1 activities in subcellular fractions of embryonic cells from three strains of <u>Drosophila melanogaster</u> .	73
Figure 2.4 Distributions of acid DNase and acid phosphatase activities in a sucrose density gradient of the small particulate fraction of a homogenate of embryonic tissue.	76
Figure 2.5 Cosedimentation of DNase-1 and Acph-1 in a sucrose density gradient.	80
Figure 2.6 Peak fractions of DNase-1 and Acph-1 activities from sucrose density gradients.	82
 <u>Chapter 3</u>	
Figure 3.1 Two profiles of the ontogeny of DNase-1.	93
Figure 3.2 Cumulative numbers of embryos produced per female from 28 to 70 hours after eclosion for three strains of <u>Drosophila melanogaster</u> .	100
 <u>Appendix</u>	
Figure 4.1 Elution profile of acid DNase activity from DNA ECTEOLA-cellulose.	116
Figure 4.2 Elution profile of acid DNase activity from Sephadex G-75.	118
Figure 4.3 SDS acrylamide gel showing position of bands possibly corresponding to major acid DNase activity.	122

INTRODUCTION

Prokaryotic deoxyribonucleases have been intensely studied with regard both to the in vitro manipulation of DNA segments and to their involvement in recombination, repair, and in restriction processes in vivo. It has also become apparent that deoxyribonucleases are present within higher eukaryotes as well. Questions concerning the function and distribution of these nucleases are especially relevant now that it is apparent that intracellular nucleases have significance in processes other than digestion. Studies on nucleases and their roles in developmental processes should increase our understanding of how DNA is processed, degraded, and redistributed within cellular organelles and tissues. This knowledge, in turn, will suggest answers to a wide variety of physiological, developmental, and evolutionary questions.

One of the most interesting model systems for an analysis of deoxyribonucleases is holometabolous insect development, during which cellular growth, differentiation, and histolysis often occur separately within different tissues and at different times. Drosophila melanogaster is the insect of choice because of the ease with which it can be manipulated genetically. Furthermore a considerable amount of information is available on its development and physiology as evidenced in the recent multivolume treatise, Genetics and Biology of Drosophila, edited by M. Ashburner and T. R. F. Wright.

This study consists of a genetic and developmental analysis of a major soluble acid deoxyribonuclease which is present throughout the life cycle of Drosophila melanogaster. The first chapter consists of a genetic and cytogenetic localization of the structural gene, DNase-1. The production and preliminary characterization of null alleles at the

locus is also treated in Chapter One. The second chapter contains an analysis of the subcellular localization of the DNase-1 gene product in embryonic tissues. Particular features of its subcellular distribution are discussed in this chapter. The third chapter presents a preliminary developmental analysis of DNase-1, in which a wild type stock and several null activity mutants are utilized. An appendix containing a regimen for the partial purification of the gene product is also included.

Chapter 1

A GENETIC LOCALIZATION AND PRODUCTION OF "NULL" ALLELES
OF THE STRUCTURAL GENE FOR THE MAJOR SOLUBLE ACID DEOXY-
RIBONUCLEASE OF DROSOPHILA MELANOGASTER.

Introduction

Deoxyribonucleases have been studied in a number of different organisms with regard to both their biological function and their usefulness in the in vitro dissection of DNA sequences. These studies on deoxyribonucleases (DNases) began in mammalian systems and resulted in the discovery and crystalization of bovine pancreatic DNase (Kunitz, 1950; Matsuda and Ogoshi, 1966). Also, a DNase activity with a pH optimum of 4.5 was identified in splenic tissue (Catchside and Holmes, 1947). This latter enzyme was first referred to as acid DNase and later, DNase II (E.C. 3.1.4.6.) (Cunningham and Laskowski, 1953).

Both the acidic pH optimum and hydrolytic action of DNase II suggest a lysosomal location within the cell. From studies of the distributions of numerous diagnostic lysosomal enzymes within rat liver cell homogenates, DeDuve et al. (1959) concluded that acid DNase is also a lysosomal enzyme. Miesel and Friedlander (1975) have shown at the ultrastructural level that DNase of the testicular cells of the moth, Ephestia cautella catalyzes a reaction which results in the preferential deposition of its product in the lysosomes of the testicular cells. In addition, the wide tissue distribution of acid DNase (see Cordonnier and Bernardi, 1968), suggests a rather general cellular function for the enzyme as, for example, degradation of foreign DNA within primary lysosomes (Bernardi, 1971).

Virtually nothing is known about the genetic control of acid DNase in those higher eukaryotes in which the enzyme has been well characterized biochemically. A genetic analysis of acid DNase is more feasible in an organism such as Drosophila melanogaster, where a number of gene-enzyme systems have been identified (MacIntyre and O'Brien, 1976).

A genetic analysis of DNase in Drosophila should also be rather straightforward since an efficient means for the electrophoretic separation and visualization of DNase activities in polyacrylamide gels has been developed (Boyd and Mitchell, 1965). In addition, Boyd (1969) has surveyed the major DNase activities present in Drosophila melanogaster at various times during development. This study included an analysis of substrate and cation requirements of the electrophoretically separable DNases. A minimum of seven distinct DNase activities were observed, of which at least two have optimal activities at low pH and exhibit the apparent EDTA activation pattern typical of most acid DNases. An analysis of DNase activities in dissected organs of Drosophila hydei at metamorphosis (Boyd and Boyd, 1970) suggests that DNases active at high pH display tissue specific distributions while the acid DNases are found in a variety of tissues. This suggests that these latter enzymes have a more generalized cellular function or functions.

This study presents a genetic analysis of the major, soluble, acid DNase in Drosophila melanogaster, in which the locus for this enzyme is mapped and cytogenetically localized using naturally occurring electrophoretic variants. In addition, a series of eight null alleles and one low activity mutant of the DNase-1 locus has been produced using EMS mutagenesis. This chapter describes the production and the isolation of those mutants.

Materials and Methods

Enzyme Assay.

Enzyme assays were performed at 37°C in 1.5 ml of a reaction mixture containing 0.5 ml of substrate (1 mg/ml highly polymerized salmon sperm

DNA (Sigma Chem. Co.), 3.8 mg/ml Na₂ EDTA) and 1.0 ml of 0.1 M citrate phosphate buffer (pH 5.0). For assay of crude extracts, flies of a given genotype were homogenized in a glass tissue grinder (VWR Scientific) in distilled water (100 mg of flies, wet weight, per ml). The homogenate was then decolorized with Norit (20 mg/ml), and centrifuged for 10 minutes on an IEC clinical centrifuge (Model MB). For assays of embryos, 150 mg of embryos, wet weight, per ml were homogenized, and the Norit treatment was omitted. 0.05 ml of the supernatant was added to each assay tube. The reaction was stopped after 60 minutes by immersing the tubes in an ice water bath and adding 2 ml of cold 10% perchloric acid. After 20 minutes, tubes were centrifuged for 15 minutes at 2,600 rpm on a Sorval GLC-1 centrifuge. Optical density of the supernatant was measured at 260 nm. Protein was determined by the method of Lowry (1951), using BSA as a standard. Reaction rates were linear for 60 minutes and over an enzyme concentration range of 2.5-20% homogenates (wet weight/volume).

Gel Electrophoresis.

Single, 0-1 day old adult flies, which had been frozen overnight, were homogenized individually in glass tissue grinders (25-100 lambda capacity) (Radnoti Glass Technology, Inc., Arcadia, Ca.) in 0.025 ml of homogenization buffer (0.01 M sodium citrate, citric acid, pH 4.7, 0.001 M Na₂ EDTA, 0.1% bovine serum albumin and 15% sucrose) and frozen overnight before use. It was found that the freeze-thaw step released more activity and preferentially increased the amount of soluble activity as compared to activity at the origin. Before electrophoresis, samples were centrifuged for 10 minutes on an IEC clinical centrifuge (Model MB) and 0.012-0.015 ml quantities of the supernatants were

subjected to electrophoresis. Gel electrophoresis was performed at 200 volts for five hours in a slab gel system (Aquebogue Machine and Repair Shop, Aquebogue, L.I., N. Y.). The running gel (about 8 cm in length) was 7.5% acrylamide containing 1.5 mg/ml salmon sperm DNA. The slot former was inserted into a spacer gel (5% acrylamide) until 0.5 cm of spacer gel separated the bottom of the pocket from the running gel. Gel solutions, DNA substrate, gel and electrophoresis buffers were made up as described in Boyd and Mitchell (1965). After electrophoresis, the gel was incubated in two changes of incubation buffer (0.06 M sodium citrate, 1 mM Na₂ EDTA, pH 4.5). Incubation time was three hours at 37°C with a buffer change after the first hour. After incubation, the gels were stained overnight in 0.2% methyl green (Kurnick, 1950), and destained with several changes of 0.2 M acetate buffer, pH 4.0 (Boyd and Mitchell, 1965).

Mutagenesis.

Stocks used in the mutagenesis experiments were homozygous for the third chromosome recessive visible markers ebony (e, 3-70.7), claret (ca, 3-100.7) and brevis (bv, 3-104.3) (see Lindsley and Grell, 1968, for a complete description of these mutants), and for the acid phosphatase-1 null activity allele, Acph-1ⁿ¹³ (Bell et al., 1972). The strain used in the null screen to recover ca containing mutagenized third chromosomes had the third chromosome constitution In(3L)P, In(3R)P, Me¹, ca/T(3;4)A2. Me¹ is a dominant visible mutation within the inversion on the left arm of the third chromosome. The inversion on the right arm of the third chromosome

inhibits recombination between ca and the ca⁺ locus in the translocation chromosome. The multiply-inverted Me¹ chromosome is balanced over the translocation T(3;4)A2.

Homozygous e ca Acph-1ⁿ¹³ by or ca Acph-1ⁿ¹³ by males were exposed to 0.023 M ethylmethane sulfonate (EMS) according to the method of Lewis and Bacher (1968). Prior to placing males on EMS, they were starved overnight in vials containing 2% agar which provided only moisture but no nutrients. Subsequent crosses for isolation of null alleles were incubated in vials or bottles with a standard cornmeal-molasses medium supplemented with live yeast under conditions of high humidity at 25°C.

Spot Test.

A method for qualitatively assaying large numbers of single flies for acid DNase activity was developed. Salmon sperm DNA (Sigma Chem. Co.) at 1.6 mg/ml in citrate buffer (0.06 M sodium citrate, 1 mM Na₂ EDTA, pH 4.5) was warmed to 50°C and brought to a final concentration of 0.96 mg/ml with a 60°C solution of aqueous 1.5% agarose (Sigma Chem. Co.). After mixing thoroughly, the solution was poured between two gel electrophoresis plates (Aquebogue Machine and Repair Shop) separated by lucite spacers (0.05" thick) and allowed to polymerize at room temperature. Following polymerization, the gel was supported horizontally on one of the plates and kept at 0°C. A fire polished pasteur pipet was used with suction to place in the gel evenly spaced wells with diameters of approximately 1.5 mm. Forty-eight individual female flies were homogenized simultaneously in single drops of H₂O at 0°C in separate wells of a microtiter plate. A 0.01 ml quantity of each homogenate was transferred to a well in the DNA-agarose gels

using marked capillary tubes. The gel was incubated at 37°C overnight under conditions of high humidity. It was then stained in 0.25% methyl green (Kurnick, 1950) and destained with several changes of 0.2 M acetate buffer, pH 4.0. Unstained areas around the wells (Figure 1.1) indicate the presence of acid DNase activity. Putative null mutants show complete staining (absence of activity) around the perimeter of the well.

Results

The DNases of Drosophila.

Drosophila melanogaster has a number of different electrophoretically separable DNase activities exhibiting various pH optima, ionic requirements, and developmental patterns of expression (Boyd, 1969). In adults, acid DNase activity is found largely in a single, anodally migrating zone and in a region near the sample origin. Enzyme activity near the origin can be decreased relative to the amount of soluble activity by subjecting crude extracts to: a) osmotic shock, b) longer homogenization, or c) increased centrifugation time. The two activities may, therefore, represent the same gene product, some of which is complexed with other proteins or is membrane-associated. An electrophoretic analysis of fifteen different laboratory stocks revealed three electrophoretic variants of the anodally migrating enzyme in adults. As a result of the genetic analysis described below, we have designated these variants: DNase-1^A (relative mobility = 1.00), DNase-1^B (relative mobility = 0.96), and DNase-1^C (relative mobility = 0.89) (see Fig. 1.2). From the same fifteen stocks, two other variants were discovered which have the same electrophoretic mobility as DNase-1^A but which differ greatly in relative activities at 25°C (Fig. 1.2).

Figure 1.1 Spot test for acid DNase activity in single fly homo-
genates. See Materials and Methods for details of the
assay. The letter "n" denotes a putative null mutation.

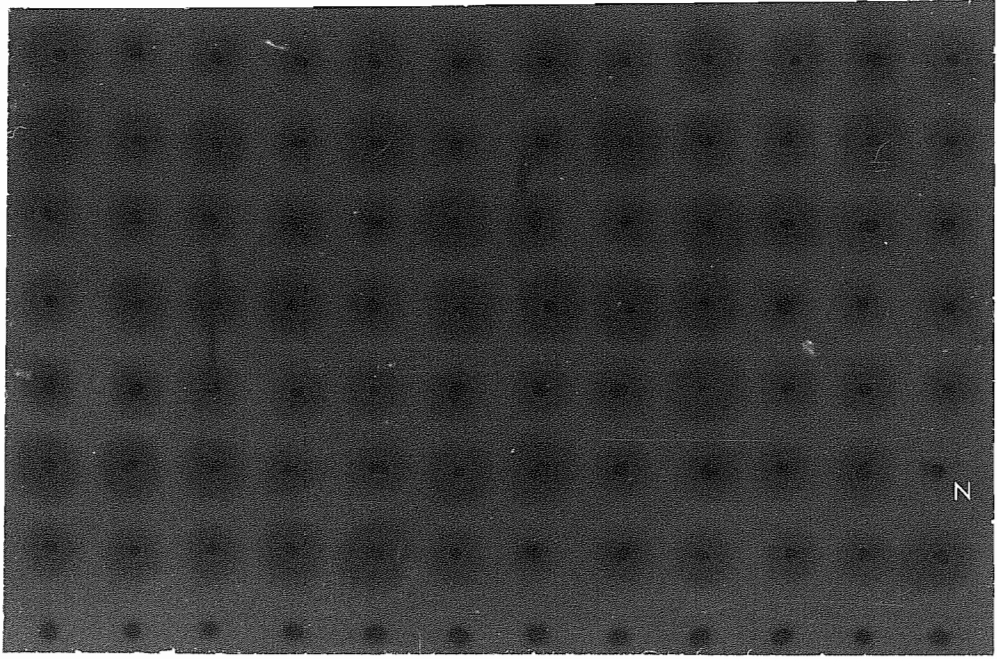
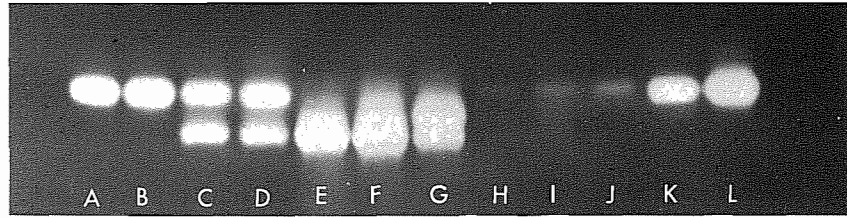

Figure 1.2 DNase-1 alleles in Drosophila melanogaster. Gels were incubated at 37°C for three hours as described in Materials and Methods. a-b, DNase-1^A homozygotes; c-d, DNase-1^A/DNase-1^C heterozygotes; e-f, DNase-1^C homozygotes; g, Cy;Sb/T(2;3)ad^{Xa} individual which is DNase-1^C/DNase-1^B; h-j, homogenates of two, four, and six adults, respectively, of a low activity variant of DNase-1; k-l, high activity variant of DNase-1 exhibiting increased activity over wild type strains in gel assays at 25°C instead of 37°C.



Crosses between stocks monomorphic for DNase-1^A and DNase-1^G patterns produced F₁ individuals which exhibit a two-banded pattern in gels (Fig. 1.2). This indicates that the enzyme is monomeric in structure (Shaw, 1965), with respect to the product of the DNase-1 gene.

Genetic Localization of DNase-1.

The DNase-1^G variant was discovered in a strain of flies homozygous for the recessive third chromosome mutant glass (gl, 3-63.1). This mutant causes a reduction in the surface area of the eye, as well as roughened facets in an irregular arrangement (Lindsley and Grell, 1968).

All of the DNase-1^A/DNase-1^G F₁'s, which were obtained from reciprocal crosses of flies monomorphic for DNase-1^A and DNase-1^G exhibit a two-band pattern on gels. This is consistent with an autosomal mode of inheritance. The F₁'s were mated and a sample of 46 F₂ individuals were examined for eye morphology and subjected to electrophoresis in order to score their DNase-1 phenotype. Nine individuals were homozygous for gl, and all of these also showed only the DNase-1^G phenotype; of the gl⁺ F₂'s, twenty-three individuals exhibited both the DNase-1^A and DNase-1^G enzymes. The remaining fourteen were monomorphic for DNase-1^A. A χ^2 analysis of F₂ progeny suggests a single locus with codominant alleles as the mode of inheritance for the DNase phenotype ($P = 0.57$). We have designated the DNase alleles simply as DNase-1^A and DNase-1^G. Furthermore, the DNase-1 gene showed complete linkage with gl in these results.

Chromosomal localization was examined more rigorously in a cross of a laboratory wild type strain monomorphic for DNase-1^A (DNase-1^A/DNase-1^A) to a stock with dominant markers on the second (Curly) and

third (Stubble) chromosomes, balanced over a translocation. This stock is designated as SM1, Cy;Sb/T(2;3)Xa (see Lindsley and Grell, 1968, for description of the mutants). This stock also has a balanced (DNase-1^B/DNase-1^C) genotype. When this stock was crossed to wild type (DNase-1^A/DNase-1^A) it was observed that the DNase-1^B allele producing an enzyme with intermediate mobility was associated with the translocation chromosomes, and the DNase-1^C allele was associated with either the dominantly marked second (Cy) or third (Sb) chromosome. From a backcross of the F₁ males to wild type DNase-1^A homozygotes, six individuals, which had the phenotypes Cy++; +;Sb, Cy;Sb, or ++, were analyzed electrophoretically. All Sb/+ individuals were DNase-1^A/DNase-1^C, while Cy individuals were both DNase-1^A/DNase-1^A and DNase-1^A/DNase-1^C; therefore, the DNase-1 locus is on the third chromosome.

Initial localization of the DNase-1 locus on the third chromosome was accomplished with the multiply-marked third chromosome ru h th st cu sr e^S ca (Lindsley and Grell, 1968). Flies from this stock are homozygous for DNase-1^A. The F₁ females from a cross of this stock to gl (DNase-1^C/DNase-1^C) were backcrossed to ru h th st cu sr e^S ca males. Reciprocal single crossover products for each of seven regions were phenotypically scored and analyzed electrophoretically. The results of this cross indicated that DNase-1 maps in the vicinity of the sr locus (62.0) on the right arm of the third chromosome. Fifty-five crossovers between cu and e^S, a segment of 20 map units in length, failed to separate the DNase locus from the sr locus, i.e., all of the crossovers between cu and e^S which were sr⁺ were also DNase-1^C/DNase-1^A and all crossovers that were sr were homozygous for DNase-1^A. This places the DNase-1 locus within 0.5 map units of sr.

Closer mapping of the locus was attempted using a stock homozygous for p^D bx sr e^S and the DNase-1^A allele. The bx locus is considerably closer to sr on the left than is cu. Females heterozygous for p^D bx sr e^S and the DNase-1 locus were crossed to p^D bx sr e^S, DNase-1^A/ p^D bx sr e^S, DNase-1^A males. Among 40 recombinants between sr and e^S, no sr-DNase recombinants were observed. Among 83 recombinants between bx and sr, however, six individuals exhibited recombination between DNase-1 and sr. Since the bx locus is at 58.8 and sr is at 62.0, the DNase locus is, therefore, placed at 61.8 ± 0.16 (s.e.).

Cytogenetic Localization of DNase-1.

Duplications were generated for each of thirty regions (see O'Brien and Gethman, 1973, for the breakpoints) spanning the two major autosomes, except for region 83 D-E, by means of a series of crosses utilizing the Y-autosome translocation stocks of Lindsley, Sandler, et al. (1972). Intercrosses between these stocks produce euploid male and female progeny as well as progeny carrying a duplication of the autosome between the two autosomal breakpoints. (All three classes of flies are phenotypically distinguishable because the Y chromosome used in the construction of these translocations carries the dominant marker Bar-Stone on the tip of its long arm and the normal allele of yellow at the terminus of its short arm). The sex chromosomes in these stocks all contain a mutant allele of yellow. The duplication flies are generated by one of the two viable combinations of gametes resulting from adjacent-1 disjunctions. See Lindsley et al. (1972) and O'Brien and Gethman (1973) for full discussions of this method.

For each of the thirty regions examined, acid DNase activities of duplication progeny were compared in spectrophotometric assays

with those of euploid sibling progeny. Of the 30 regions assayed, two regions, region 18 (67C-70C) and region 26 (88C-91B) exhibited a reproducibly dosage dependent response (Fig. 1.3). Dosage dependency was considered significant when the duplication/euploid acid DNase activity ratio was equal to or greater than 1.5. Based on several replicate experiments, average specific activities of homogenates of the duplication and euploid flies from regions 18 and 26 were in ratios of 1.61 and 1.83, respectively. On this basis, region 26 was chosen for further analysis. The significance of the region 18 dosage dependency is discussed below (see Discussion).

Region 26 can be further divided into three subregions using translocation stocks G48, L142, B116 and A89 (see Table 1.1). Duplications for these subregions are generated from the crosses: G48 x L142 (88C-89C), L142 x B116 (89C-90E), and B116 x A89 (90E-91B). Results of assays of flies duplicated for these subregions are shown in Figure 1.4. No significant elevation of DNase activity is observed for subregion (88C-89C); however, for both subregions (89C-90E) and (90E-91B), the duplication flies from reciprocal crosses consistently exhibit a higher specific activity than their euploid sibs regardless of the sex of individual classes. If the structural gene is within region 26, then, based on elevations of DNase activity in duplication flies, it must be in either subregion (89C-90E) or (90E-91B), but by the nature of the crosses, it cannot be in both.

A series of crosses, making use of the electrophoretic variants discussed above, were performed to determine which of the two subregions contains the structural gene for DNase-1 (Fig. 1.5). In the first cross scheme (A), virgin females of constitution C(1)RM,

Figure 1.3 Acid DNase activities of homogenates of flies segmentally aneuploid for regions of the second and third autosomes designated by numbers 1-30. Each bar represents one determination of the ratio of duplication to euploid DNase activity on a wet weight basis (see Materials and Methods) where duplication and euploid individuals are of the same sex.

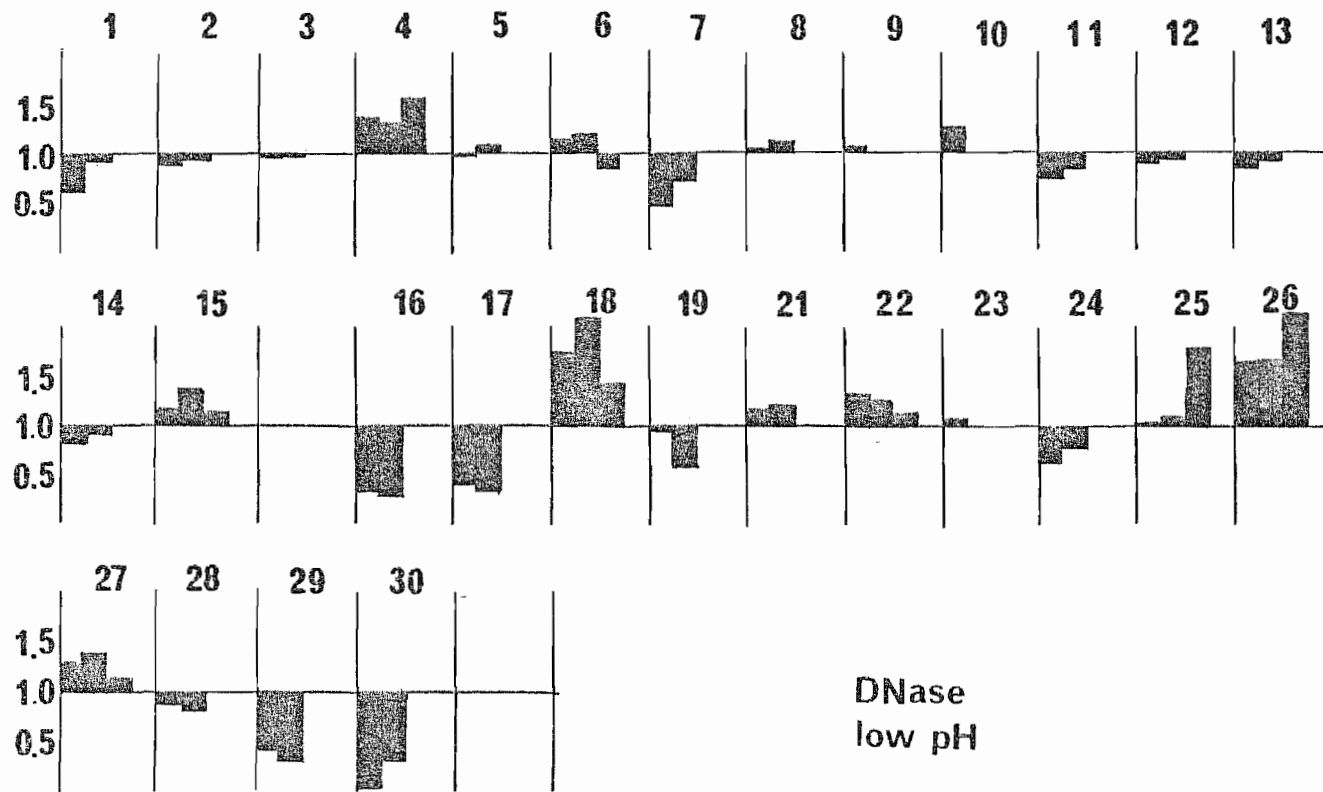

Table 1.1 Drosophila melanogaster stocks used in cytological localization of DNase-1.

<u>Stock</u>	<u>Genotype</u>		<u>Breakpoints</u>
	<u>Male</u>	<u>Female</u>	
A89	Y ^S ·X·Y ^L , In(1)EN, y/T(2;3)/In(3LR) TM6, Ubx ^{67b} e	c(1)RM, y/T(2;3)/In(3LR) TM6, Ubx ^{67b} e	I* ; 91B
B116	"	"	L ; 90E
L142	"	"	L ; 89C
G48	"	"	S ; 88C
XYIII	Y ^S ·X·Y ^L , In(1)EN, y; In(3LR)TM6, Ubx ^{67b} e/Sb	Y ^S ·X·Y ^L , In(1)EN, y/Y ^S ·X·Y ^L , In(1) EN, y; In(3LR)TM6, Ubx ^{67b} e/Sb	
TM1, Me'	cm ct ⁶ su(Hw) ² bx bxd/In(3LR)TM1, Me', ri, sbd ²	cm ct ⁶ su(Hw) ² bx bxd/In(3LR)TM1, Me', ri, sbd ²	
Df(3R) P14	Df(3R) P14/T(2;3)ap ^{Xa}	Df/(3R) P14/T(2;3)ap ^{Xa}	deficient from 90C2-D1 to 91A2-3 (Lindsley and Grell, 1968)

*L = long arm of Y, S = short arm of Y

Figure 1.4 Acid DNase specific activities of homogenates of flies aneuploid for Region 26 and each of three subregions, 88C-89C, 89C-90E, and 90E-91B. Each bar represents one determination of the ratio of duplication to euploid DNase specific activity. Protein determination was by the Lowry method. Duplication and euploid sibs were of the same sex. $Df(3R) \underline{Sbd}^{105}$ and $T(2;3)\underline{X}^a$, two stocks having breakpoints within Region 26 were also assayed for specific DNase activity relative to an Oregon R wild type strain.

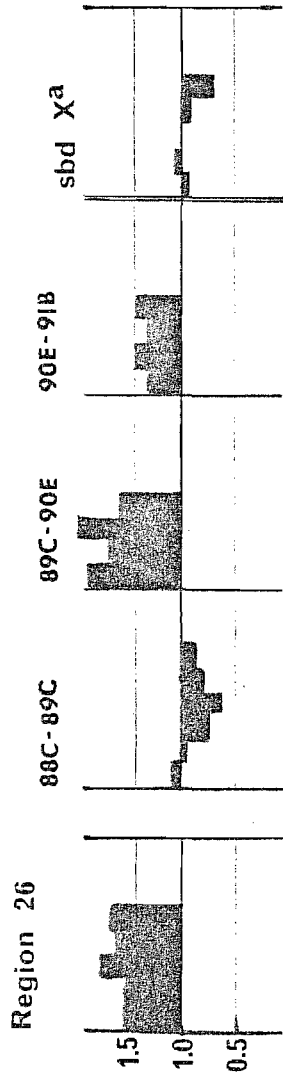
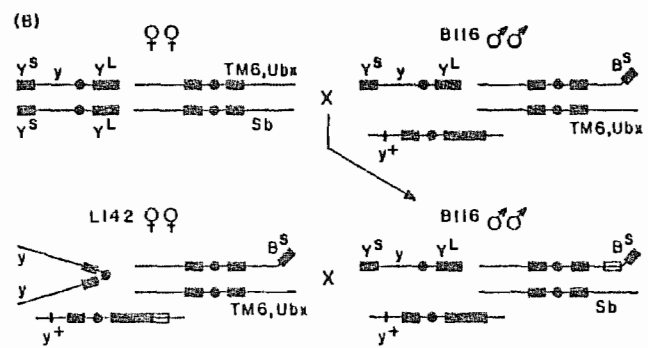
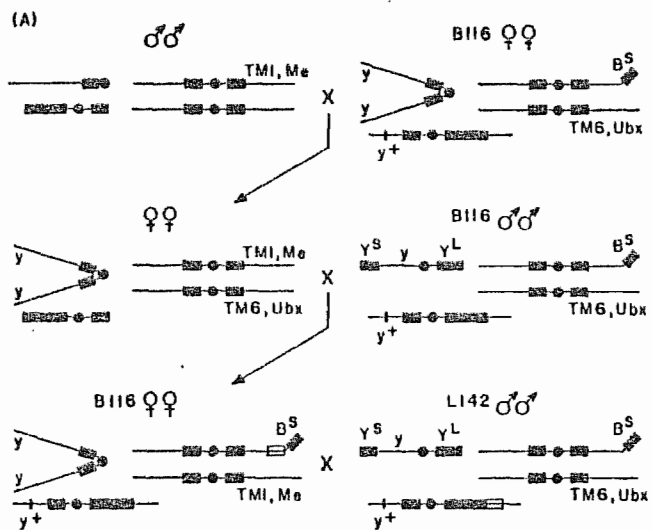

Figure 1.5 Cross schemes used to determine the cytogenetic location of DNase-1. For further description of stocks, see Table 1.1. Light, boxed regions of chromosomes correspond to the LB subregion. The Sb chromosome in cross scheme (B) contains the DNase-1^C allele.



CHROMOSOME	DNASE ALLELE
TM6, Ubx	C
TM1, Me	C
BI16 T (Y;A)	A
LI42 T (Y;A)	A

$y/T(Y;3)/In(3LR)TM6, \underline{Ubx}^{67b} \underline{e}$ were mated to $\underline{cm} \underline{ct}^6; \underline{su(Hw)}^2 \underline{bx} \underline{bx}d/$
 $In(3LR)TM1, \underline{Me} \underline{ri} \underline{sbd}^2$ males; F_1 females bearing the attached-X
 chromosomes, a free Y chromosome, and two third chromosome balancers
 (TM1/TM6), were then crossed to B116 males whose genotype is noted
 in Table 1.1. Female progeny from this cross having the phenotype
 $y^+, \underline{B}^S, \underline{Ubx}^+$ were then mated to L142 or A89 males (see Table 1.1),
 and single euploid, duplication, and deficiency progeny were frozen,
 homogenized, and examined electrophoretically. Flies carrying a
 deficiency for these smaller subregions survive along with their
 euploid sibs. In the second cross scheme (Fig. 1.5 B), $Y^S \cdot X \cdot Y^L,$
 $In(1)EN, y/Y^S \cdot X \cdot Y^L, In(1)EN, y; In(3LR)TM6, \underline{Ubx}^{67b} \underline{e}/\underline{Sb}$ virgin females
 were mated to B116 males; B116 F_1 males ($y^+ \underline{B}^S$) containing the Sb
 chromosome were then mated to L142 or A89 virgin females and single
 euploid, duplication, and deficiency progeny were frozen, homogenized
 and examined electrophoretically. The T(Y;3) chromosomes contain
 the DNase-1^A allele in these crosses while the balancer third chromo-
 some contains the DNase-1^C allele. As seen in Table 1.2, the predicted
DNase-1 phenotype of the deficiency sibling progeny differs depending
 on whether or not the DNase-1 locus is within the subregion. Results
 of the two sets of crosses (Fig. 1.6) show that the DNase-1 locus lies
 within the middle subregion (89C-90E). For both cross schemes
 (Fig. 1.5) the individuals deficient for subregion (90E-91B) contain
 two different DNase-1 alleles and cannot, therefore, be deficient
 for the DNase-1 locus. Conversely, in crosses involving the (89C-90E)
 subregion, the deficiency flies exhibit only the product of the slow
 allele of DNase-1 (on the balancer chromosome), and the duplication
 individuals apparently have three doses of the DNase-1 gene: the

Table 1.2 Expected phenotypes and DNase-1 genotypes of progeny of crosses shown in Fig. 1.4.

<u>Progeny</u>	<u>Expected Phenotype</u>		<u>DNase-1 Genotype</u>	
	<u>Cross A</u>	<u>Cross B</u>	<u>within LB subregion</u>	<u>outside LB subregion</u>
Eup	♂ $y^+ B^S Ubx$	♂ $y^+ B^S Sb$	A/C	A/C
Eup	♀ $y^+ B^S Ubx^+$	♀ $y^+ B^S Ubx$	A/C	A/C
Dup	♀ $y^+ B^S (Ubx)^*$	♂ $y^+ B^S Sb^+$	A/A/C	A/C
Def	♂ $y^+ B^S Ubx^+$	♀ $y^+ B^S Sb$	C	A/C

*Ubx cannot be scored reproducibly in the presence of two other Ubx⁺ alleles. Because Ubx (3-58.8) is in this subregion, it is necessary to score duplication progeny by the absence of the Me phenotype. This can generally be done in B^S/B^{S+} females which have a "wide" Bar eye.

Figure 1.6 DNase-1 phenotypes of individuals euploid or aneuploid for two subregions of Region 26. In each subregion, one euploid individual of each sex is shown with males on the left, females on the right. The DNase-1 locus is found within subregion (89C-90E). The (90E-91B) duplication individual has an abnormally low expression of the DNase-1^C allele.

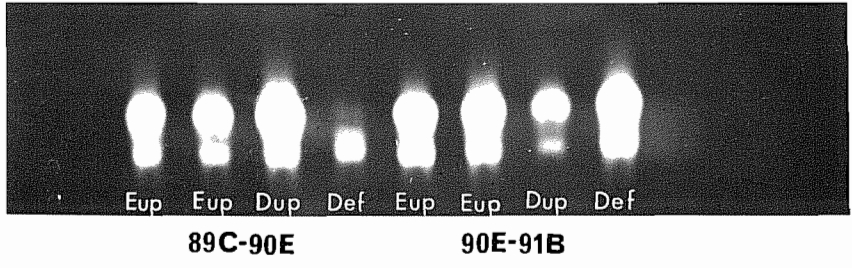

slow allele on the balancer chromosome, as well as two doses of the fast allele from the translocation chromosomes. Placement of the DNase-1 locus within the middle subregion limits the site of the locus to a region from 89C to 90E on the salivary gland chromosome map.

Because the DNase-1 locus was to be genetically mapped, crosses similar to the one shown in Figure 1.5 B were performed in which the Sb-containing third chromosome in the male was replaced by chromosomes containing the recessive visible mutations ss (3-58.5) or gl (3-63.1) presumed to be in the vicinity of the (89C-90E) subregion. Flies deficient for the (89C-90E) subregion show a spineless phenotype while flies deficient for the (90E-91B) subregion show the glass phenotype. Thus, ss, gl, and DNase-1 are all within Region 26 and ss is within the same subregion as DNase-1.

Deficiency Df(3R)P14 (Lindsley and Grell, 1968) has a proximal breakpoint (90C2-D1) which overlaps the distal part of the subregion (89C-90E) by 6 to 10 bands. In order to determine whether the DNase-1 locus lies within the P14 deficiency, flies from a stock containing Df(3R)P14, balanced over the translocation T(2;3)ap^{Xa} were crossed to a DNase-1^C/DNase-1^C stock. The Df(3R)P14/T(2;3)ap^{Xa} flies are monomorphic for DNase-1^B. The results indicate that the Df(3R)P14/T(2;3)ap^{Xa} stock contains only one allele of DNase-1^B associated with the translocation chromosome and that the Df(3R)P14 chromosome apparently has no allele of DNase-1. Since the DNase-1 locus lies within both the (89C-90E) subregion and Df(3R)P14, it must be between 90C2-D1 and 90E as indicated in Figure 1.7.

Figure 1.7 Cytogenetic location of DNase-1. The region common to Df(3R)P14 and subregion LB contains the DNase-1 locus. The left breakpoint of Df(3R)P14 may be toward the right as far as 9OD1 decreasing the size of the region containing DNase-1 to 5-7 bands in length.

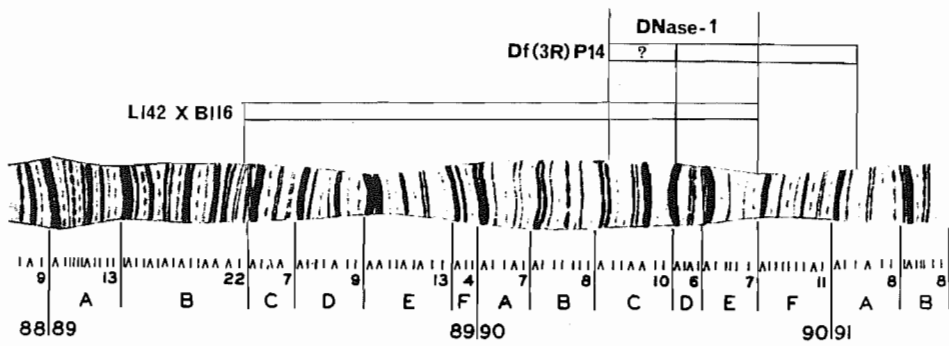

Production of DNase-1 Null Alleles.

The cross scheme used to generate null alleles at the DNase-1 locus is shown in Figure 1.8. The second and third generations in the cross scheme were necessary for a separate analysis which was not part of the present study, and are included here only for the sake of completeness. Mutagenized, homozygous DNase-1^A ca Acph-1ⁿ¹³ by males were mated en masse to females having a third chromosome carrying ru and Pr (Lindsley and Grell, 1968), balanced over the multiply inverted TM3 Sb, Ser chromosome, hereafter designated TSS. Single F₁ virgin females containing a mutagenized third chromosome balanced over TSS were backcrossed to ru Pr/TSS males. Non-Pr, TSS sons and daughters from each cross were mated and the resulting TSS male progeny containing a single mutagenized third chromosome were mated to females heterozygous for the third chromosome balancer TSS and a third chromosome containing the deficiency Df(3R)P14 (Lindsley and Grell, 1968). This deficiency extends from 90C2-D1 to 91A2 and includes the DNase-1 locus (Detwiler and MacIntyre, 1978) (see above, Fig. 1.7). Non-TSS female progeny from this cross contained the deficiency and the mutagenized third chromosomes and were assayed by means of the spot test for the presence or absence of acid DNase activity. When such females exhibited no detectable DNase activity, sibling non-TSS males were mated to In(3L)P, Me¹ ca/T(3;4)A2 females. The mutagenized DNase-1 null chromosome was recovered from this cross in In(3L)P, Me¹ ca/DNase-1ⁿ ca males. These males were mated to TSS/ru Pr females and TSS, Me⁺ male and female sibs (TM3, Sb Ser/DNase-1ⁿ ca Acph-1ⁿ¹³ by) were crossed to establish a balanced stock of each presumptive null mutant.

Figure 1.8 Cross scheme for generation of null alleles at the DNase-1 locus. A description of the nomenclature is found in the text.

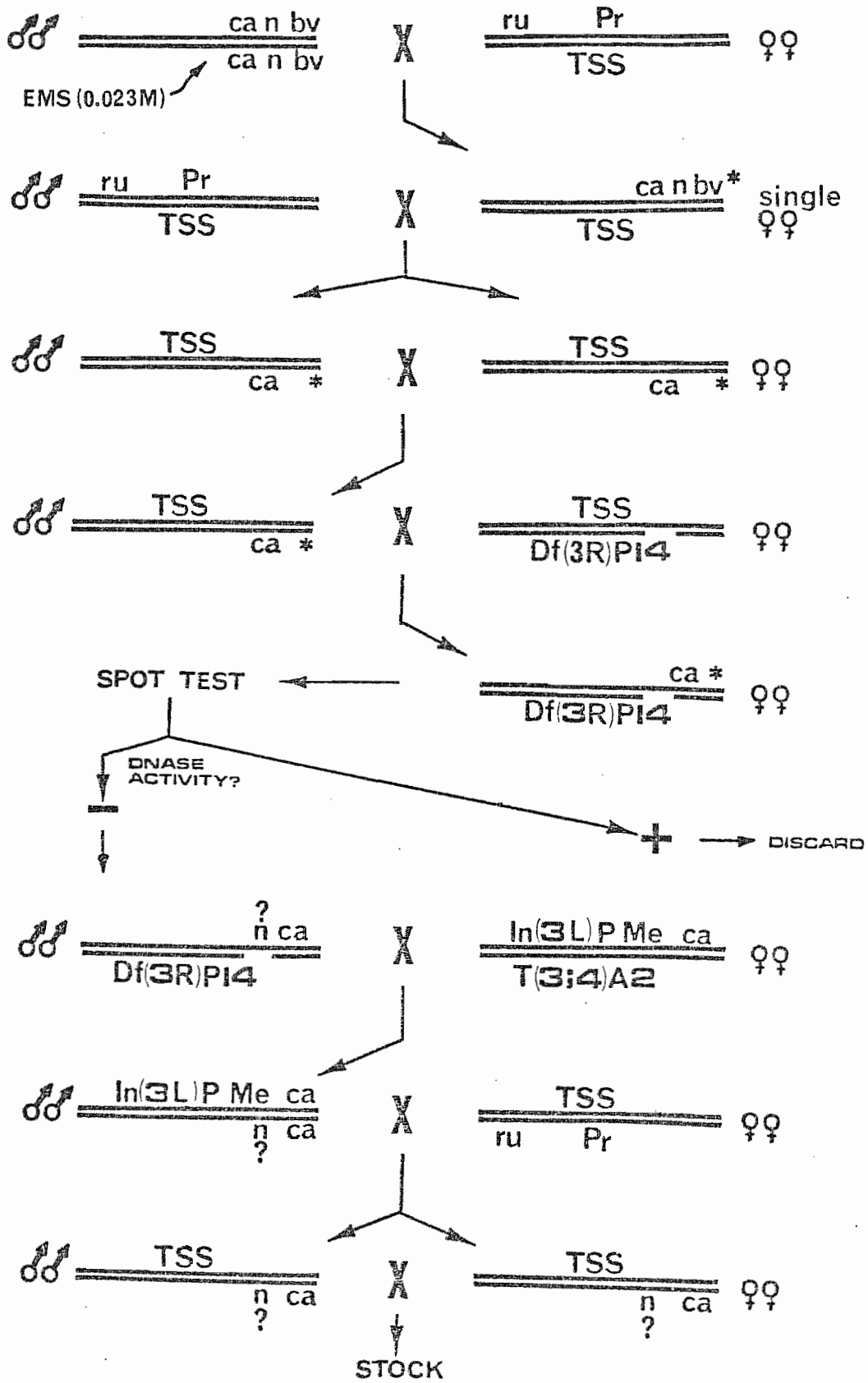

All strains containing putative null and low activity DNase-1 alleles were retested using the gel assay of Boyd and Mitchell (1965). Results are shown in Figure 1.9 and listed in Table 1.3. The criterion for a null variant was the absence of acid DNase activity in the region of the gel where DNase-1^A gene product would be expected. On this basis eight "null" variants, n³²³, n³²⁴, n³³⁴, n⁴⁰², n⁴⁰³, n⁴⁵⁹, n⁵⁶⁰ and n¹⁰⁴¹ were isolated from among 1143 tested chromosomes (frequency = .007). Superscripts refer to the numerical position in the spot test of the mutant individuals. Strains showing reduced activity of the mutagenized allele were designated "low activity" variants (n¹⁻). Of the two low activity strains shown in Table 1.3, n^{1mh}, kindly provided by J. C. Stone, was discovered in a laboratory stock. The low activity fails to complement Df(3R)P14 (J. Stone, personal communication) and in gels its product comigrates with the DNase-1^A gene product. n¹¹⁴ was recovered as a lethal over Df(3R)P14 and also showed reduced acid DNase activity relative to that of the mutagenized stock containing a DNase-1^A allele.

Further crosses were made using the method of O'Brien and Shimada (1974) to remove induced non-allelic lethals and the markers ca Acph-1ⁿ¹³ and by from chromosomes containing the DNase-1 null alleles n³²³, n³²⁴, n³³⁴, n⁴⁰² and n⁴⁵⁹. TSS/Def(3R)P14 ca⁺ virgin females were mated to TSS/DNase-1ⁿ, ca Acph-1ⁿ¹³, by males and progeny from this cross were allowed to intermate. After 2-3 generations wild type males and virgin females were selected and mated to maintain each stock. The DNase-1 phenotypes of several individuals

Figure 1.9 Enzyme activities in acrylamide gels of low and null activity alleles of the DNase-1 locus. Nulls were derived from a normal (A) allele and isolated over DF(3R)P14. For homozygotes, two individuals were homogenized in 25 ul; 15 ul were inserted into gels. For mutant alleles heterozygous over the TM3 balancer third chromosome (visible DNase-1^C activity), one or two individuals were homogenized as indicated. Samples in panel A: (1) n³²³/TM3; (2) n³²³/n³²³; (3) n³²⁴/TM3; (4) n³²⁴/n³²⁴; (5) n⁴⁰³/TM3; (6) n⁴⁰³/TM3 (two individuals); (7) n⁴⁵⁹/TM3; (8) n⁴⁵⁹/n⁴⁵⁹; (9) n⁵⁶⁰/TM3; (10) n⁵⁶⁰/TM3 (two individuals); (11)-(12) TM3/ru Pr (DNase-1^C/DNase-1^A). Samples in panel B: (1) n^{lmh}/n^{lmh}; (2) n^{lmh}/n^{lmh} (two individuals); (3) n^{lss}/n^{lss}; (4) n^{lss}/n^{lss} (two individuals); (5) TM3/n¹⁴; (6) TM3/n¹⁴ (two individuals); (7) TM3/n³³⁴; (8) n³³⁴/n³³⁴; (9) TM3/n⁴⁰²; (10) n⁴⁰²/n⁴⁰²; (11) TM3/n¹⁰⁴¹; (12) TM3/n¹⁰⁴¹ (two individuals); (13) TM3/ru Pr (DNase-1^A/DNase-1^C).

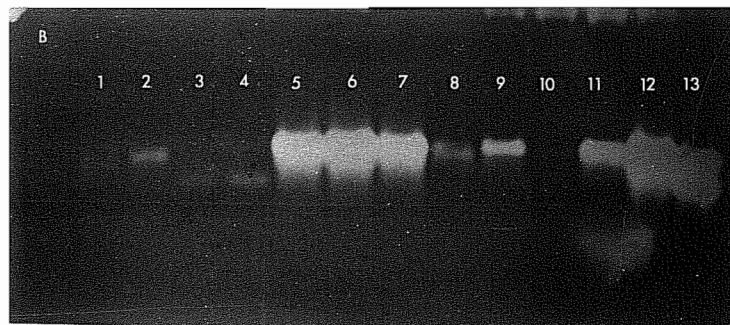

Table 1.3 DNase-1 activity mutants.

<u>Class</u>	<u>Designation</u>	<u>Source</u>
null	n323	EMS
	n324	EMS
	n334	EMS
	n402	EMS
	n403	EMS
	n459	EMS
	n460	EMS
	n1041	EMS
low activity	nlmh	LS
	n114	EMS

EMS = ethyl methane sulfonate, LS = laboratory stock

from each stock were examined electrophoretically to confirm the absence of DNase-1 activity. No DNase-1 activity was observed indicating that individuals of all five stocks had a third chromosome complement that was wild type for all markers used in the analysis but genotypically either $\underline{DNase-1}^n/\underline{DNase-1}^n$ or $\underline{DNase-1}^n/Df(3R)P14$. After several further generations, fifteen virgin females of each stock were mated en masse to homozygous $\underline{sr} \underline{e}^S$ males (the sr locus is included in Df(3R)P14). Of over a hundred progeny examined no sr progeny were seen in any of the crosses indicating that Df(3R)P14 was either lost from each stock or at frequencies less than 10%. For each stock single \underline{sr}^+ males ($\underline{DNase-1}^n/\underline{sr} \underline{e}^S$) were mated to TSS, $\underline{e}/\underline{ru} \underline{Pr}$ females. TSS, \underline{e}^+ progeny from these crosses were used to construct stocks homozygous for each of the DNase-1 null alleles.

Extracts of two flies homozygous for each of the null alleles (listed above) were assayed in gels for DNase-1 activity (see Fig. 1.9). Gels were then slowly destained over a period of 2-3 days. In each case, while no $\underline{DNase-1}^A$ activity is observed, a faint band of activity (1-10% of wild type, C. Detwiler, unpublished observation) is present at or slightly ahead of the position to which the $\underline{DNase-1}^C$ gene product migrates. The intensity of the band is variable between the null strains ($\underline{n}^{334} \underline{n}^{324}$, \underline{n}^{402} , $\underline{n}^{459} \underline{n}^{323}$) but is consistent within any single strain. In strains \underline{n}^{403}/TSS , \underline{n}^{560}/TSS , and \underline{n}^{1040}/TSS the presence or absence of this band can not be determined due to the presence of the $\underline{DNase-1}^C$ gene product from the TSS chromosome.

Test Tube Assays.

In order to estimate the contribution of the DNase-1 gene product to total acid DNase activity, test tube assays were performed on homogenates of embryos (150 mg/ml) and adults (100 mg/ml) of selected null stocks and null heterozygotes as indicated in Table 1.4. Activity values are based on wet weight determinations. It can be seen that the product of the DNase-1 locus is responsible for most but not all of the acid DNase activity present in wild type homogenates.

Discussion

DNA-Acrylamide Gel Electrophoresis.

The number and variety of methods used to detect and quantify DNase activity have increased greatly since the description by Kunitz of a spectrometric assay (Kunitz, 1950; Daoust, 1957; Boyd and Mitchell, 1965; Melgar and Goldthwait, 1968; Champoux and Dulbecco, 1972; Holloman and Holliday, 1973; Grdina et al., 1973; Bacchetti and Benne, 1975; Meisel and Friedlander, 1975). Our technique is an adaptation of the Boyd and Mitchell technique (1965) for use in a slab gel system. This system has the advantage of ease of preparation, simplicity of sample comparison, and a thin cross-sectional gel area allowing for rapid diffusion of stains and buffers into the gel. Also, because of the thinness of the gel, DNA fragments, resulting from enzymatic digestion, can diffuse out of the gel matrix, making the elution and presoak steps of

Table 1.4 Acid DNase activities of null stocks.

<u>Genotype</u>	<u>Adults</u>	<u>Embryos</u>
wild type (BV1)	0.18* (<u>±</u> 0.01)	0.13 (<u>±</u> 0.03)
n ^{lmh} /n ^{lmh}	-----	0.03 (<u>±</u> 0.01)
n ^{lss} /n ^{lss**}	-----	0.05***
n ³²⁴ /n ³²⁴	0.07 (<u>±</u> 0.01)	0.03 (<u>±</u> 0.01)
n ³³⁴ /n ³³⁴	-----	0.05 (<u>±</u> 0.02)
n ⁴⁰² /n ⁴⁰²	-----	0.03 (<u>±</u> 0.01)
n ³²³ /n ⁵⁶⁰	0.02 (<u>±</u> 0.01)	-----
n ⁴⁰³ /n ⁵⁶⁰	0.02 (<u>±</u> 0.01)	-----
n ³²⁴ /n ³²³	0.03 (<u>±</u> 0.01)	-----

* the average value and range for two determinations are reported.

** n^{lss} exhibits reduced DNase-1 activity in gel assays; the stock is homozygous for the recessive visible mutant spineless (see footnote to Fig. 1.2, h-j).

***ss embryo value represents a single determination.

Boyd and Mitchell (1965) unnecessary. This system is adaptable; in fact, it has already been used successfully in our laboratory to detect Mg^{+2} stimulated alkaline DNases as well as RNases.

The electrophoretic assay in slab gels reveals considerable variability among the DNases of Drosophila melanogaster that we have examined. For DNase-1, three alleles with differing mobilities as well as three different activity variants were recovered from a sample of only 15 different laboratory strains. A comparable amount of apparently genetic variation in an alkaline pH optimum (8.25), Mg^{+2} stimulated DNase has been detected in 13 different laboratory strains (Detwiler, unpublished observation). More information concerning the function of these nucleases must be known before the significance of this large amount of variability can be assessed.

Of particular interest from the standpoint of genetic regulation are the high and low activity variants of the DNase-1 locus. These kinds of variants exist for XDH activity in D. melanogaster (Chovnick et al., 1977) and in D. pseudoobscura (Prakash, 1977) and map genetically to the vicinity of the XDH structural gene. For one of these alleles in D. melanogaster (ry^{+4}), Chovnick et al. (1977) have shown that the site (i409) controlling the activity level of the allele is recombinationally separable from sites controlling its electrophoretic mobility. They have further shown that this "regulatory site" is to the left beyond the limits established for the structural gene. A similar analysis of the DNase-1

locus using available alleles with altered enzyme activities would be valuable as a further test of the generality of the rosy locus model.

DNase activity near the origin in DNA acrylamide gels may be due to either a protein-protein interaction such as a membrane association of DNase activity or, as Boyd (1969) has suggested, the DNase activity may interact strongly with and/or bind to the substrate which is present in the gel. Experiments in which DNA was omitted from the top 2.5 cm of the running gel suggest that enzyme-substrate interaction is not responsible for the immobilization of acid DNase activity near the origin (Detwiler, unpublished observation). Acid DNases are generally lysosomal enzymes and, in the case of rat liver lysosomes, acid DNase activity has been purified from lysosomal membranes (Dulaney and Touster, 1972). This suggests that the presence of acid DNase activity at the gel origin may be a result of membrane association.

DNase-1 Localization.

Several different arguments suggest strongly that a structural gene for DNase-1 is at 61.8 on the right arm of the third chromosome: 1) electrophoretic variants specified by codominant alleles were used to genetically map DNase-1 to this position; 2) a survey of the second and third chromosomes for gene dosage sensitive regions using Y-autosome translocation stocks revealed dosage sensitivity in a region containing ss and gl, both of which map to within three map units of DNase-1; 3) DNase-1 is also within Df(3R)P14

which contains sr and gl (Lindsley and Grell, 1968); and 4) in a deficiency generated by a cross between two Y-autosome translocations with autosomal breakpoints near sr and gl, the electrophoretic variant coded by the DNase-1 allele normally carried on the translocation chromosome was missing. This last demonstration is a critical one in this study. O'Brien and Gethmann (1973) noted that a region of a chromosome containing the structural gene for a given enzyme should produce strict dosage dependency in enzyme assays in which three, two, or one copy(s) of the locus are present. Several authors have subsequently utilized the Y-autosome translocations to locate putative structural genes (Kiger and Golanty, 1977; Moore, 1977; Pipkin et al., 1977; Hodgetts et al., 1975). Data generated by this method become difficult to interpret when several loci within the genome contribute enzyme products with similar substrate specificities. The method can still be used, however, regardless of the number of interfering gene products if alleles specifying electrophoretically discrete forms (allozymes) of one or more of the enzymes are available. A general method for cytogenetically locating a gene-enzyme system with different electrophoretic variants is shown in Figure 1.10. Flies with a chromosome carrying an allele specifying an electrophoretic variant different from the one found in the T(Y;A) stocks, i.e., the "alternative allele" of the gene-enzyme system are crossed to females containing autosomal balancers similar to those used in the translocation stocks but having a sex chromosome constitution of $Y^S \cdot X \cdot Y^L$, $In(1)EN/Y^S \cdot X \cdot Y^L$, $In(1)EN$,

Figure 1.10 General model for the use of electrophoretic variants and T(Y;A) stocks for placement of a locus with respect to a given subregion of the second or third chromosome. E-1^F, E-1^S - fast and slow alleles at a locus within the generated subregion. E-2^F, E-2^S - fast and slow alleles at a locus outside the generated subregion. BAL - Balancer chromosome, Dom - dominant visible mutant associated with balancers, Dl - distal breakpoint on autosome, Pl - proximal breakpoint on autosome. Thick regions represent heterochromatin. E-1, E-2 are placed on left arm of balancer chromosome to indicate rearrangement of wild type sequence due to multiple inversions in the Balancer.

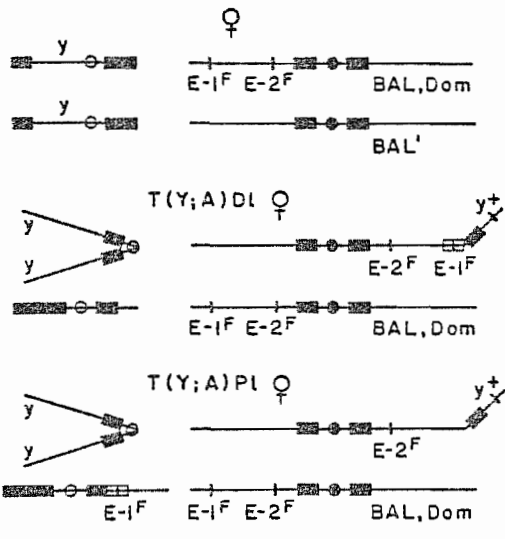
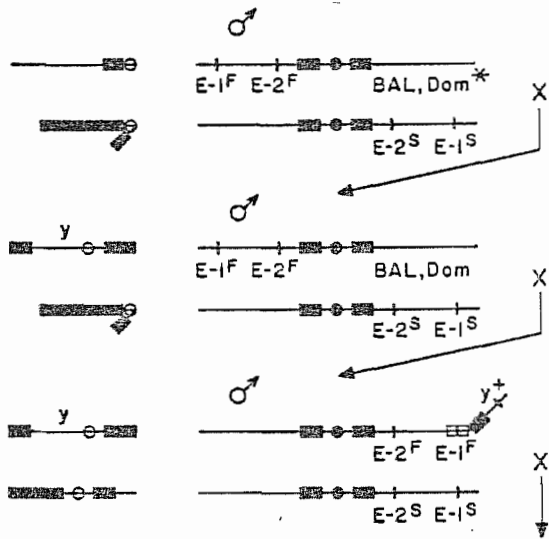

PROGENY

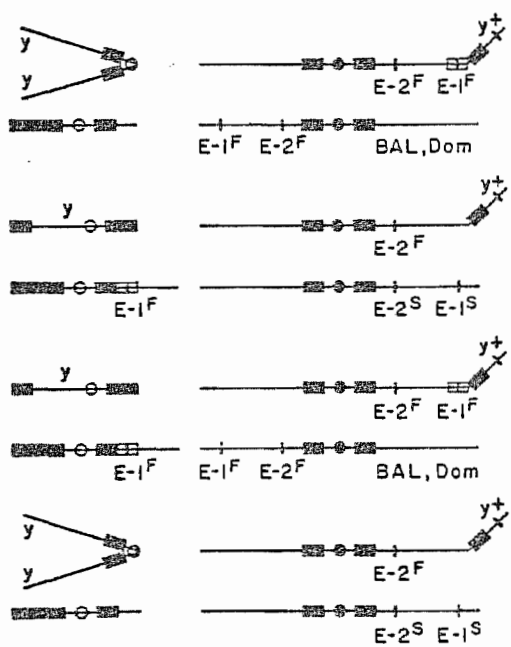

VISIBLE PHENOTYPE

♀, Dom

♂, Dom⁺

♂, Dom

♀, Dom⁺

ELECTROPHORETIC PHENOTYPE

F/F F/F

F/S F/S

F/F/F F/F

S F/S

as shown in the first step. Males heterozygous for a balancer and the chromosome containing the alternative allele are then crossed to females of the translocation stock with the distal breakpoint delimiting the region which will be made deficient. Males are then selected which carry the translocation marked with y^+ and/or B^S , and the chromosome carrying the alternative allele. Finally, these males are mated with females containing the translocation chromosomes with autosomal breakpoint proximal with regard to the region in question. If the structural gene lies within the deficiency, the deficiency-carrying flies will exhibit only one form of the enzyme which will be the product of the alternative allele originally introduced in the first cross. If the structural gene lies outside of the region delimited by the two autosomal breakpoints, all progeny will, without exception, exhibit the product of the allele associated with the translocation chromosome. In this manner "dosage dependency" for a given locus can be demonstrated directly in a gel, separated from other gene products with similar substrate specificities.

The availability of electrophoretic variants together with the ability to generate specific deficiencies using segmental aneuploidy makes the analysis of other loci affecting acid DNase activity potentially useful. The survey of the second and third autosomes for dosage sensitive regions, as described above (Figs. 1.2 and 1.3) suggest seven other regions which, when duplicated, show significant alterations (>1.5 fold) of acid DNase activity by comparison with euploid siblings. Four regions, when duplicated,

show significant depressions of acid DNase activity (Regions 16, 17, 29, 30). No additional information is presently available regarding the further localization or significance of these depressions. The other three regions (Regions 4, 18, subregion 90E-91B) show elevations of acid DNase activity in duplication sibs. Of these, two, region 18 and subregion 90E-91B, have been further studied.

Flies duplicated for the (90E-91B) subregion yield extracts exhibiting moderate elevation of DNase activity relative to their euploid sibs (Fig. 1.4). These elevations are more pronounced in females than in males. Gel assays of euploid and duplication sibling extracts show that the increased DNase activity in duplication flies appears to be due to a relative decrease in the activity of the DNase-1^A gene product in sibling euploid female extracts. The DNase-1^A allele is associated with the translocation chromosome in these crosses, and is closer to the translocation breakpoint in euploid sibs than in duplication sibs. These data suggest that position effect variegation is responsible for the difference in acid DNase activity between euploid and duplication sibs. If the activity of the DNase-1^A allele is being suppressed in the euploid fly, then the apparent increase in duplication progeny is actually due to a depression of DNase activity in the euploids. This depression should be greater in females than in males where extra Y heterochromatin might be expected to depress the extent of position effect variegation (Spofford, 1977). As indicated above, this difference in extent of depression of DNase activity in euploid male and female

extracts has been repeatedly observed in test tube assays (Detwiler, unpublished observations). This further suggests that the apparent dosage sensitivity of the (90E-91B) subregion results from position effect variegation of the DNase-1^A allele.

The elevation of DNase activity in flies duplicated for region 18 (67C-70D) has been examined by subjecting them to gel electrophoresis alongside their euploid sibs. The association of DNase-1 alleles is such that both duplication and euploid flies are DNase-1^A/DNase-1^C heterozygotes. The effect of duplication of region 18 is a significant increase in the activity of both DNase-1^A and DNase-1^C gene products. This generalized increase in activity differs from the result observed when region 26 is duplicated. There, the increase is evident only in the amount of DNase-1 product coded by the allele carried on the translocated chromosomes, and hence in duplicate (see Fig. 1.6). It is possible that a regulatory gene, controlling the overall expression of the DNase-1 locus, lies within region 18. Alternatively, regions 18 or 4 may cause quantitative increases in DNase-1 activity by contributing structural genes for a second subunit to the enzyme.

DNase-1 Null Alleles.

The induction and analysis of null alleles in an enzyme's structural gene can be a useful approach to understanding the in vivo function of the enzyme itself. The value of a "spot" test for the selection of individuals carrying a null allele is now well established from studies on Acph-1 (Bell et al., 1972), Adh (Grell et al.,

1968; O'Donnell, 1975), α Fuc (B. Bond, personal communication), B galactosidase (D. Knipple, personal communication), and α GPDH (O'Brien and MacIntyre, 1978). The spot test described for acid DNase activity ought to be applicable to virtually any system with a diffusible enzyme and a polymeric substrate for which a relatively specific stain is available. The use of the small deficiency, Df(3R)P14, which includes the DNase-1 locus, made a qualitative interpretation of the spot test possible; a null allele over a deficiency gave no activity. This is significant because there is considerable variation in activity among the single-fly extracts used in the spot test, and detection of null heterozygotes would require further refinements of the test.

The dosage of EMS used resulted in a relatively high frequency of null alleles (1 null allele per 143 chromosomes tested) when compared with efficiency of this mutagen in other Drosophila gene-enzyme systems (O'Brien and MacIntyre, 1978). This high frequency may be due to the relative size of the DNase-1 locus, or to other unknown factors affecting the mutability of the locus.

The induced null mutations were studied after producing five stocks, each of which was homozygous for a different DNase-1 null allele. This made the observation of the homozygous null mutant phenotype in gels in the absence of any wild type DNase-1 gene product possible. The faint bands of activity observed in extracts of each strain could be the result of either 1) a DNase-1 gene product in which both the net charge and enzymatic activity had been

mutationally altered, or 2) the presence of an independent nuclease that comigrates with DNase-1 in gels but is not visible in the presence of wild type DNase-1 activity. While the data do not permit a clear choice between these interpretations, the relatively common occurrence of "leaky" mutants in other systems (O'Brien and MacIntyre, 1978), and the slight electrophoretic variation of the faint bands among the various null mutant stocks suggest that the bands represent the action of altered DNase-1 gene product. Leakiness has been observed among induced nulls in frequencies of up to 75% following selection screens in which EMS was the mutagen (O'Brien and MacIntyre, 1978). Factors that determine the fraction of the induced nulls that will be leaky in a given system include: 1) the sensitivity of the enzyme assay to diminished amounts of activity, 2) the frequency with which mutational events lead to "leaky" versus "absolute" nulls, which will be a function of the primary, secondary and tertiary structures of the gene product; and 3) functional constraints on the gene product ("absolute" nulls may be lethal or infertile). Although no data exist which allow comparison of assay sensitivities or enzyme structures, it is possible (since all null alleles examined were leaky) that homozygosity for an "absolute" null allele of DNase-1 results in lethality. In order to test this hypothesis, a selection screen would be required in which null mutant heterozygotes are produced and detected in gel assays. If heteroallelic, heterozygous null combinations from this screen could be found which were not viable,

then the hypothesis would be substantiated. Nevertheless, given the results of the present selection scheme and data from test tube assays (Table 1.4), it is apparent that levels of acid DNase activity far below those of wild type individuals do not seriously impair viability and fertility of the DNase-1 null stocks. In this respect, DNase-1 is similar to numerous other *Drosophila* gene-enzyme systems in which the virtual absence of the gene product has little or no effect on viability (O'Brien, 1973). The presence in null extracts of residual activity at the origin of the gel, together with the test tube assay results from the null stocks (see Table 1.4), suggest that one or several other acid DNases exist in the organism. These other enzymes may allow the organism to physiologically compensate for the absence of the DNase-1 gene product.

BIBLIOGRAPHY

- Bacchetti, S. and R. Benne (1975). Purification and characterization of an endonuclease from calf thymus acting on irradiated DNA. *Biochim. Biophys. Acta* 390, 285.
- Bell, J. B., MacIntyre, R. J. and A. P. Olivieri (1972). Induction of null-activity mutants for the acid-phosphatase-1 gene in *Drosophila melanogaster*. *Biochem. Genet.* 6, 205-216.
- Bernardi, G. (1971). "Spleen Acid Deoxyribonuclease". In Boyer, P. (ed.), *The Enzymes*, 3rd ed., Vol. IV, Academic Press, New York. pp. 271-287.
- Boyd, J. B. (1969). *Drosophila* deoxyribonucleases. I. Variation of deoxyribonucleases in *Drosophila melanogaster*. *Biochim. Biophys. Acta* 171, 103.
- Boyd, J. B. and H. Boyd (1970). Deoxyribonucleases of the organs of *Drosophila hydei* at the onset of metamorphosis. *Biochem. Genet.* 4, 447.
- Boyd, J. B. and H. K. Mitchell (1965). Identification of deoxyribonucleases in polyacrylamide gel following their separation by disc electrophoresis. *Anal. Biochem.* 13, 28.
- Catchside, D. G. and B. Holmes (1947). The action of enzymes on chromosomes. *Symp. Soc. Exp. Biol.* 1, 225.
- Champoux, J. J. and R. Dulbecco (1972). An activity from mammalian cells that untwists superhelical DNA - A possible swivel for DNA replication. *Proc. Nat Acad. Sci.* 69, 143.
- Chovnick, A., Gelbart, W., and M. McCarron (1977). Organization of the rosy locus in *Drosophila melanogaster*. *Cell* 11, 1.
- Cordonnier, C. and G. Bernardi (1968). A comparative study of acid deoxyribonucleases extracted from different tissues and species. *Can. J. Biochem.* 46, 989.
- Cunningham, L. and M. Laskowski (1953). Presence of two different deoxyribonucleodepolymerases in veal kidney. *Biochim. Biophys. Acta* 11, 590.
- Daost, R. (1957). Localization of deoxyribonuclease in tissue sections. *Exp. Cell Res.* 12, 203.
- DeDuve, C. and Beaufay (1959). Tissue fractionation studies - Enzymic release of bound hydrolases. *Biochem. J.* 73, 604.

- Detwiler, C. R. and R. J. MacIntyre (1978). A genetic and developmental analysis of an acid deoxyribonuclease in Drosophila melanogaster. Biochem. Genet. 16, 1113-1138.
- Dulaney, J. T. and O. Touster (1972). Isolation of deoxyribonuclease II of rat liver lysosomes. J. Biol. Chem. 247, 1424-1432.
- Grdina, D. J., Lohman, P. H. M., and R. R. Hewitt (1973). A fluorometric method for the detection of endodeoxyribonuclease on DNA-polyacrylamide gels. Anal. Biochem. 51, 255.
- Hodgetts, R. E. (1975). The response of dopa decarboxylase activity to variations in gene dosage in Drosophila: a possible location of the structural gene. Genetics 79, 45.
- Holloman, W. F. and R. Holliday (1973). Studies on a nuclease from Ustilago maydis. I. Purification, properties, and implications in recombination of the enzyme. J. Biol. Chem. 248, 8107.
- Kiger, J. A. and E. Golanty (1977). A cytogenetic analysis of cyclic nucleotide phosphodiesterase activities in Drosophila. Genetics 85, 609.
- Kunitz, M. (1950). Crystalline deoxyribonuclease. I. Isolation and general properties, spectrophotometric method for the measurement of deoxyribonuclease activity. Jl. Gen. Phys. 33, 349.
- Kurnick, N. B. (1950). The quantitative estimation of deoxyribonucleic acid based on methyl green staining. Exp. Cell Res. 1, 151.
- Lewis, E. B. and Bacher, F. (1968). Method of feeding ethyl methane-sulfonate (EMS) to Drosophila males. Drosophila Inform. Serv. 43, 193.
- Lindsley, D. L. and E. H. Grell (1968). Genetic variation of Drosophila melanogaster. Carnegie Institute of Washington Publication No. 627.
- Lindsley, D. L., Sandler, L., Baker, B. S., Carpenter, A. T. C., Denell, R. E., Hall, J. C., Jacobs, P. A., Miklos, G. L. G., Davis, B. K., Gethmann, R. C., Hardy, R. W., Hessler, A., Miller, S. M., Nozawa, H., Parry, D. M., Gould-Somero, M. (1972). Segmental aneuploidy and the genetic gross structure of the Drosophila genome. Genetics 71, 157.
- Lowry, O. H., Rosebrough, N. J., Farr, A. L., and R. J. Randall (1951). Protein measurement with the Folin phenol reagent. J. Biol. Chem. 193, 265.
- MacIntyre, R. J. and S. J. O'Brien (1976). Interacting gene-enzyme systems in Drosophila. Ann. Rev. Genet. 10, 281.

- Matsuda, M. and H. Ogoshi (1966). Preparation and properties of deaminodeoxyribonucleic acid. *Biochim. Biophys. Acta* 119, 210.
- Meisel, S. and M. Friedlander (1975). Deoxyribonuclease localization at the ultrastructural level. *Israel J. Med. Sci.* 11, 404.
- Melgar, E. and D. A. Goldthwait (1968). Deoxyribonucleic acid nucleases. I. The use of a new method to observe the kinetics of deoxyribonucleic acid degradation by deoxyribonuclease I, deoxyribonuclease II, and Escherichia coli endonuclease I. *J. Biol. Chem.* 243, 4401.
- Moore, G. P. (1977). Biochemical and genetic characterization of kynurenine formamidase in Drosophila melanogaster. Ph.D. Thesis, Syracuse University, Syracuse, New York.
- O'Brien, S. J. (1973). On estimating functional gene number in eukaryotes. *Nature, New Biol.* 242, 52-54.
- O'Brien, S. J. and R. C. Gethmann (1973). Segmental aneuploidy as a probe for structural genes in Drosophila: Mitochondrial membrane enzymes. *Genetics* 75, 155.
- O'Brien, S. J. and Y. Shimada (1974). The α glycerophosphate cycle in Drosophila melanogaster. IV. Metabolic, ultrastructural, and adaptive consequences of α GPDH "null" mutations. *J. Cell Biol.* 63, 864-882.
- O'Brien, S. J. and R. J. MacIntyre (1978). "Genetics and Biochemistry of Enzymes and Specific Proteins of Drosophila." In: *The Genetics and Biology of Drosophila*. Ed. by M. Ashburner and T. R. F. Wright. Academic Press, New York.
- Pipkin, S. B., Chakrabartty, P. K., and T. A. Bremner (1977). Location and regulation of Drosophila fumarase. *J. Hered.* 68, 245.
- Prakash, S. (1977). Allelic variants at the xanthine dehydrogenase locus affecting enzyme activity in Drosophila pseudoobscura. *Genetics* 87, 159-168.
- Shaw, C. R. (1964). The use of genetic variation in the analysis of isozyme structure. *Brookhaven Symp. Biol.* 17, 117.
- Spofford, J. M. (1977). Position-effect variegation in Drosophila. In Ashburner, M. and E. Novitski (eds.), *The Genetics and Biology of Drosophila*, Vol. 1c, Academic Press, New York. pp. 62-167.

Chapter 2

A SUBCELLULAR LOCALIZATION OF THE GENE PRODUCT OF THE
DNASE-1 LOCUS IN DROSOPHILA MELANOGASTER.

Introduction

One frequently used approach to understanding the biological function of cellular constituents has been the technique of subcellular tissue fractionation. Differential and isopycnic centrifugation analyses have been used for the subcellular localization of enzyme activities, following the classic work of DeDuve et al. (1955). This general method for analyzing the fractions of tissue homogenates led to the use of "marker enzymes" which are diagnostic of a particular subcellular fraction. Early in these studies, acid phosphatase became established as one of the few acid hydrolases which were widely characteristic of the lysosomal or "light mitochondrial" fraction of various tissue homogenates (DeDuve et al., 1955; Novikoff, 1961). Gradually many hydrolases (Barret, 1972) came to be assigned a lysosomal location, often on the basis of their association in subcellular fractions with acid phosphatase. There has been, however, a growing appreciation of the heterogeneity with regard to the enzyme content of lysosomes, even within the same tissue (Beaufay, 1972). This has made histochemical and cytological criteria necessary complements to the biochemical criterion when a given enzyme is assigned to a particular subcellular location.

The applications of analytical tissue fractionation have been limited during the study of insects, possibly because of the difficulty of reproducibly fractionating tissue that is bound within a rigid chitinous exoskeleton (but see Henrikson and Clever, 1972).

Even more rarely have these techniques been applied to eukaryotes in which the genetic locus responsible for the enzyme of interest is known.

In order to better understand the processing of DNA during insect development, we have been studying the enzyme DNase-1 in the tissues of Drosophila melanogaster. DNase-1 has a pH optimum of 4.8 and shows an apparent activation in the presence of EDTA. A structural locus for the enzyme has been mapped genetically to 61.8 on the third chromosome and cytogenetically localized on the salivary gland chromosome map to a position within the interval 90C2-D1 to 90E. In addition, a locus modifying the quantitative expression of the enzyme has been localized to the interval 67C to 70C on the left arm of the third chromosome (Detwiler and MacIntyre, 1978). The developmental profile for the enzyme has also been established and eight null activity mutants have been produced at the structural locus (Detwiler, 1979). DNase-1 is maximally expressed during pupation - a period of extensive tissue histolysis.

The present study was undertaken in order to assign a subcellular location to the DNase-1 gene product. While no histochemical data are presented here, the distribution of acid DNase activity is compared with that of acid phosphatase which has been localized within the lysosomes of Drosophila melanogaster by means of ultrastructural histochemical analysis of ovarian and salivary gland tissue preparations (Anastasia-Sawicki and MacIntyre, 1975, Sawicki, 1976).

Materials and Methods

Stocks.

Three different stocks were used for these studies. A wild type strain, BV1 (from Blacksburg, Virginia) was kindly provided by Dr. Bruce Wallace. The DNase-1 (3-61.8) null strain, DNase-1ⁿ³²⁴ was described previously (Detwiler, 1979). The Acph-1ⁿ¹³ strain, homozygous for a null allele of the Acph-1 locus (3-101.1) was isolated by Bell et al. 1972).

Embryo Collection.

Strains used for embryo collection were reared in half pint bottles on standard cornmeal-molasses medium topped with 2 mls of a live yeast suspension, and a layer of dry granular yeast. During the period of peak emergence, bottles were cleared and adults collected four days later. Adults from twenty-four bottles were added to six egg laying chambers similar in design to those of Hildreth and Brunt (1962) except that vented petri dishes (100 x 15 mm) covered with gauze were used instead of plastic tubes. Egg laying medium was that of Kriegsten et al. (1974). It was supplemented with Norit A (Pfanstiehl Laboratories) to darken the color and poured into petri dish lids (100 x 15 mm). After hardening, a 0.5 cm wide strip was trimmed from the outer edge of the media and yeast paste (40% yeast, 60% H₂O) was brushed onto the center of the surface of the medium, covering an area of 3 cm in diameter. Two days before embryos were desired, egg laying chambers were

placed on the prepared medium under conditions of high humidity at 25°C. After 24 hours the medium was replaced with a medium containing fresh yeast paste. Twenty hours later embryos were harvested into 0.12 M NaCl using a rubber spatula. Chambers were used over a period of 2-3 days for embryo collection.

Subcellular Fractionation.

Subcellular fractionation of embryos (Figure 2.1) was carried out according to a modification of the method of Henrikson and Clever (1972). Embryos were washed free of feces and yeast in 0.12 M NaCl, folded into a Nitex (48 μ M) bag, dechorionated in 2-3% NaOCl for 90 seconds at 0°C, and rinsed in several changes of 0.12 M NaCl. Embryos were then weighed, suspended in H buffer (0.165 M Tricine, pH 7.5, 0.25 M sucrose, 10 mM KCl, 10 mM MgCl₂) (15% w/v), and gently ruptured in a Dounce homogenizer using 10-12 passages with a loose fitting pestle. This and all subsequent steps were carried out at 0-4°C. The extent of cell breakage was checked with phase microscopy; at least 70% of nuclei were released into solution. The homogenate was then filtered through Nitex (48 μ M) and centrifuged at 43000 g x min in an SS-34 head of a Sorval RC-2B centrifuge to pellet nuclei and larger cell debris. The supernatant was recentrifuged at 500,000 g x min. The pellet from this spin consisted of a small particulate (SP) fraction (by phase microscopy) and the supernatant was taken to represent the soluble (S) fraction of the homogenate. The nuclear or large particulate (LP) fraction described above was cleared of large cellular debris and undisrupted

Figure 2.1 Scheme for the subcellular fractionation of Drosophila
embryos. Details are given in the text.

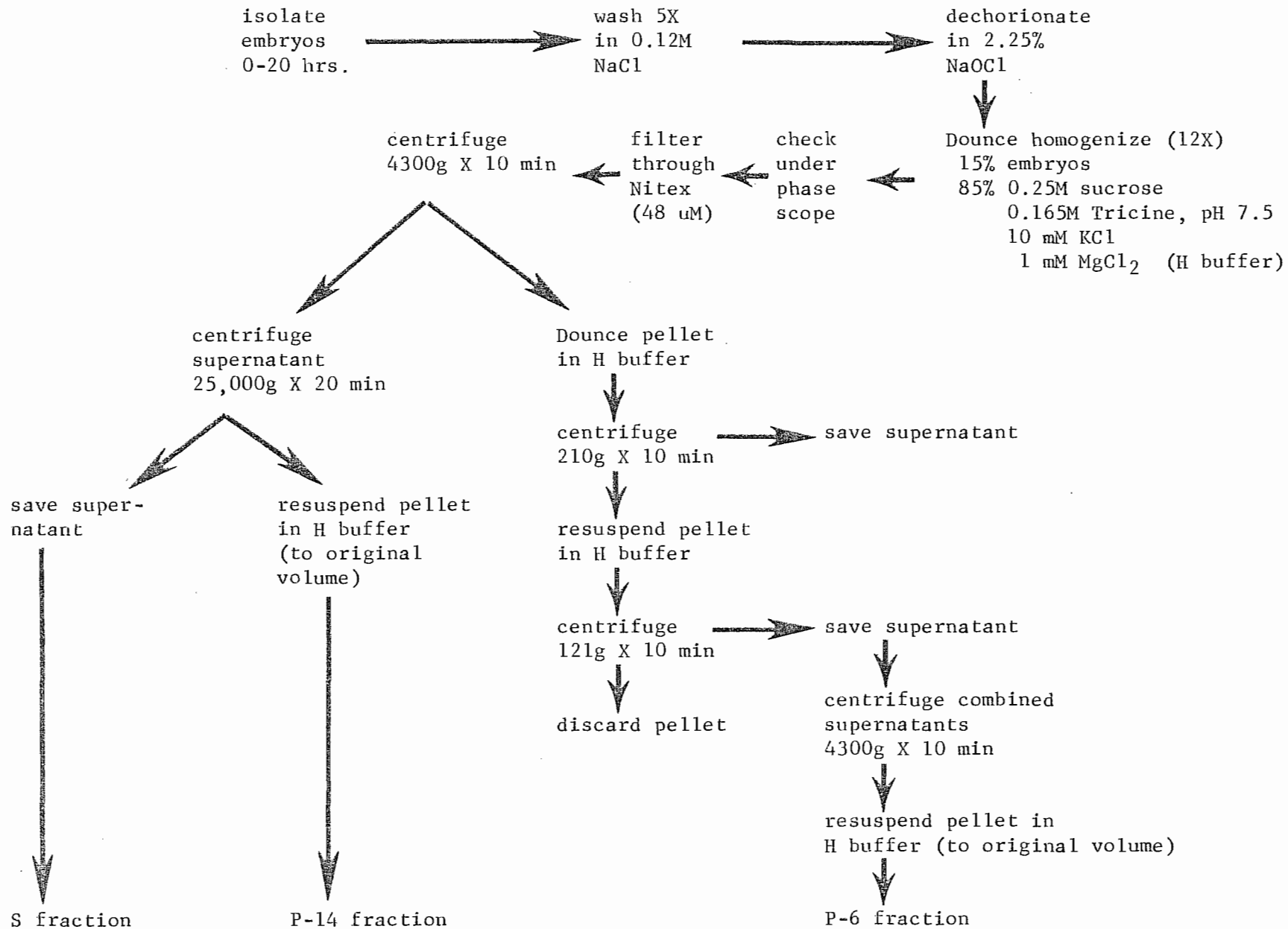

material by resuspension in a Dounce homogenizer in H buffer, centrifugation at 2100 g x min, resuspension of the resulting pellet in H buffer and recentrifugation at 1210 g x min. The final pellet was discarded and the combined supernatants (the LP fraction) were collected by centrifugation at 43,000 g x min. This fraction was largely nuclei and α -yolk spheres as judged by phase microscopy. All fractions were brought to the original volume of the homogenate with H buffer containing 0.1% Triton-X100 and frozen at -20°C prior to assays for enzyme activities. For some samples, distilled water or 0.1% Triton-X100 in H buffer were used for homogenization in place of H buffer to test the effects of hypotonicity or detergent on enzyme activity distributions in the various fractions.

Density Gradient Equilibrium Centrifugation.

For density gradient analysis of the SP fraction, SP pellets were suspended in 0.1 M Na_2SO_4 , a reversible inhibitor of acid DNase (Detwiler, unpublished observation; Bernardi, 1971), in H buffer (0.83 ml/gm embryos) and layered onto a 23 to 50% w/w sucrose gradient made up with H buffer. The gradients were centrifuged at 51,000 x g for 7 hours at 4°C in a Beckman Model L5-50 ultracentrifuge, SW 50L rotor. Thirty-seven ten-drop fractions were collected and frozen. Sucrose concentrations in the gradient were derived from refractive indices determined on a Bausch and Lomb Abbe 3-L Refractometer at 22°C .

Assays.

Test tube assays for acid DNase activity (Detwiler and MacIntyre, 1978) and acid phosphatase activity (MacIntyre, 1971) have been reported elsewhere. α -glycerophosphate dehydrogenase activity was assayed by following the reduction of NAD at 340nm (O'Brien and MacIntyre, 1972).

The DNA-acrylamide gel electrophoretic assay is that of Boyd and Mitchell (1965) as modified by Detwiler and MacIntyre (1978). After centrifugation for 10 minutes on an IEC clinical centrifuge (Model LB), ten and twenty-five μ l samples of supernatants of LP, SP, and S fractions were subjected to electrophoresis in DNA acrylamide gels. For acid phosphatase determinations, fifteen μ l samples were subjected to electrophoresis and stained as described by MacIntyre (1971). For gel assays of gradients, ten peak fractions (a total of 1.5 mls) were concentrated to 125 μ l in a Micro-ProDiCon concentrator (Bio-Molecular Dynamics). 25 μ l (DNase-1) or 15 μ l (acid phosphatase) aliquots of this sample were used for electrophoresis. Densitometry of the gel samples was carried out on a Canalco Model LG Densitometer.

Results and Discussion

Acid DNase Activity in Subcellular Fractions of *Drosophila* Embryos.

An analysis of the subcellular distribution of acid DNase activity was undertaken using embryonic tissues. Embryonic tissue was chosen for two reasons: 1) compared to other stages of the life cycle, embryos are less heterogeneous with respect to cell

type (in this regard, a cultured cell line, DM2 of Schneider, exhibited no detectable DNase-1 activity (Detwiler, unpublished observation)) and 2) embryonic tissues, since they lack chitin, can be gently disrupted with minimum damage to intracellular structures. Homogenates of embryos were subdivided into three fractions: a large particulate fraction (LP), a small particulate fraction (SP), and a soluble fraction (S), by the series of differential centrifugations outlined in Materials and Methods. After subjecting the particulate fractions to Triton-X100, followed by freezing and thawing of all fractions, acid DNase, acid phosphatase and α -glycerophosphate dehydrogenase (α -GPDH) activities were determined. Three separate fractionation experiments were performed, and replicate assays were done on each fraction for each enzyme. Results are shown in Table 2.1. Activity values are reported as percentages of the total activity in the homogenate. The range of values is reported after each mean value.

A necessary control for these experiments was the determination of "total relative activities" which are a measure of the total enzyme activity in all fractions of a homogenate relative to the total enzyme activity in all fractions of the corresponding isotonic homogenate. These values were generally close to unity with the possible exception of DNase activity in the Triton-X100 homogenates. This apparent increase in total DNase activity could be due to differences in the initial degree of polymerization of the DNA substrate used in the assays or possibly to increased release of

Table 2.1 Mean relative activities of acid DNase, acid phosphatase, and aGPDH in three subcellular fractions of embryonic cells of Drosophila melanogaster.*

<u>Enzyme</u>	<u>Fraction</u>	<u>Homogenization Medium</u>		
		<u>isotonic</u>	<u>hypotonic</u>	<u>detergent</u>
Acph	LP	50.3 ± 6.5	12.0 ± 3.0	1.3 ± 0.5
	SP	32.0 ± 7.0	27.7 ± 7.0	16.0 ± 1.5
	S	17.7 ± 0.6	60.3 ± 4.0	82.7 ± 2.0
	Total Relative Activity	1.00	0.90	0.84
DNase	LP	29.0 ± 7.0	8.0 ± 2.0	0.0 ± 0
	SP	38.7 ± 6.5	30.7 ± 6.0	14.7 ± 8.0
	S	32.3 ± 3.5	61.3 ± 5.0	85.3 ± 8.0
	Total Relative Activity	1.00	1.14	1.40
aGPDH	LP	2.6 ± 0.5	2.0 ± 1.0	0.3 ± 0.5
	SP	10.0 ± 4.5	12.0 ± 4.0	1.3 ± 1.0
	S	87.4 ± 4.9	86.0 ± 5.0	98.4 ± 1.0
	Total Relative Activity	1.00	0.83	1.00

*each value represents an average of six determinations: two assays of each of three separate preparations.

DNase activity resulting from the increased exposure of the homogenate to the detergent.

For isotonic homogenates (0.25 M sucrose, no detergent), specific enzyme activities were determined based on measurements of total protein (Lowry et al., 1951) in each fraction. From these values, relative specific enzyme activities, based on total activity in the homogenate, were calculated for each fraction. The relative specific activity for each fraction is then plotted vs. percent of total protein present in the fraction ("DeDuve plots") as shown in Figure 2.2. In each plot the fractions represented in order from the left are: LP, SP and S. The rectangular area for each fraction is a measure of the relative distribution of enzyme activity in each subcellular fraction. The mean relative activities and the relative specific activities of acid DNase indicate that it is significantly more abundant in the small particulate fraction of embryonic cells following fractionation under isotonic conditions. This result is consistent with a lysosomal location for acid DNase, assuming that the majority of the mitochondria and lysosomes are present in the small particulate fraction. Considerable acid DNase activity is also present in the soluble (S) fraction. Given the fragility of lysosomal membranes (Beaufay, 1972), however, some of this activity is probably due to lysosome breakage during homogenization and some acid DNase, freed in solution due to lysosome rupture, may be nonselectively adsorbed to a variety of cellular constituents (Beaufay, 1972) found in either the (LP) or (S) fractions. On the other hand, some acid DNase activity may originate

Figure 2.2 DeDuve plots of acid DNase, acid phosphatase and α -glycerophosphate dehydrogenase activities in Drosophila embryonic tissue. Fractions are plotted in the order of their isolation (from left to right), LP, SP and S. Each fraction is represented in the ordinate scale by its relative specific activity (percentage of total activity/percentage of total protein). In the abscissa scale, each fraction is represented (cumulatively from left) by its percentage of total protein.

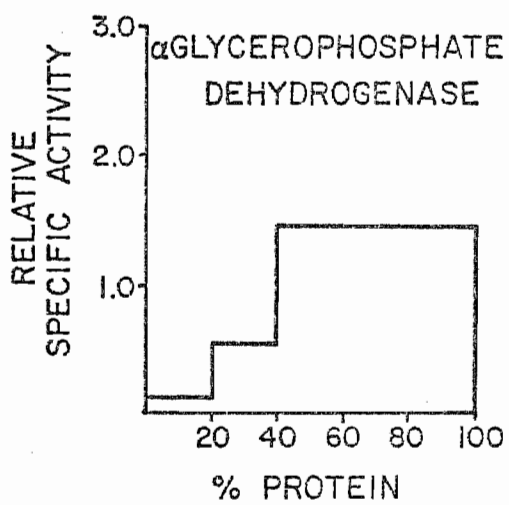
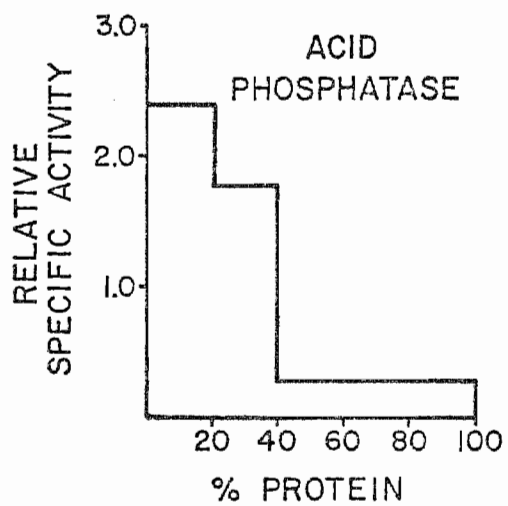
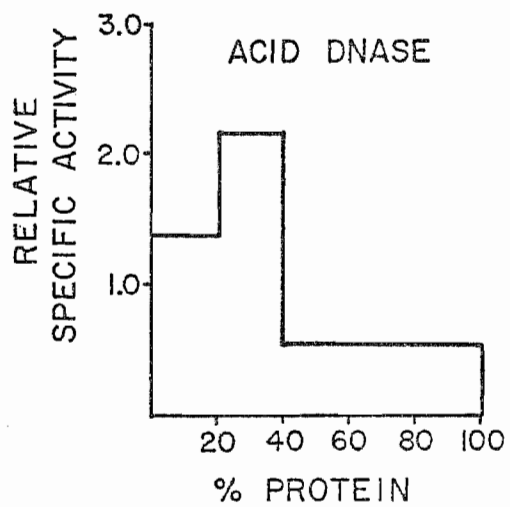

in the (S) fraction, which probably contains some lysosomes as well as the peroxisomal and microsomal fractions of these homogenates.

The existence of acid DNase in the large particulate fraction may mean that acid DNase is found in or functions in embryonic nuclei which may also be the case in calf thymus nuclei (Slor and Lev, 1971). It is more probable however that lysosomes are present in the (LP) fraction in the form of lysosomal aggregates, some of which in embryos appear to be as large as nuclei (Sawicki and MacIntyre, 1977).

Acid phosphatase, which has been shown to be a lysosomal enzyme from electron microscope studies of Drosophila salivary gland tissue (Anastasia-Sawicki and MacIntyre, 1975), exhibits, in embryonic tissue, a higher relative specific activity in the (LP) fraction. A peculiarity of embryonic tissue which supports this result is the presence in early embryos of α -yolk spheres which contain large amounts of acid phosphatase activity (Sawicki, 1976). These yolk spheres, being similar in size to nuclei, would be found in the (LP) fraction, increasing the relative amount of acid phosphatase activity found there.

The relative specific activity of α -GPDH is highest in the soluble fraction as would be expected for a cytoplasmic enzyme (Sacktor and Cochran, 1957; O'Brien and MacIntyre, 1972).

The latency of the acid hydrolase activities (DeDuve et al., 1955) was demonstrated by homogenization of embryonic tissue in either distilled water ("hypotonic") or in H buffer supplemented

with Triton-X100 ("detergent"). As can be seen in Table 2.1, acid DNase and acid phosphatase activities both exhibit latency; there is a considerable shift of activity from the particulate fractions to the soluble fraction. This shift is common for enzymes which, under isotonic homogenization conditions, are isolated from exogenous substrates within membrane delimited particles. The α -GPDH activity distributions by contrast, were not greatly affected by membrane disruption. In summary, the high specific activity of acid DNase in the SP fraction and its latency prior to membrane disruption suggest that the majority of acid DNase in Drosophila embryonic tissue is found within small membrane bound particles. This observation is consistent with a lysosomal localization for acid DNase activity.

Distribution of DNase-1 in Subcellular Fractions.

In Drosophila melanogaster, acid DNase and acid phosphatase activities result mainly from the products of two genetically determined loci: DNase-1 (Detwiler and MacIntyre, 1978) and Acph-1 (MacIntyre, 1966). From studies of null activity mutants it has been determined that about 77% of acid DNase activity in embryos (Detwiler, 1979) and > 90% of acid phosphatase activity in adult flies (Bell and MacIntyre, 1973) are contributed by the gene products of these two loci (Detwiler, 1979). Acrylamide gel assays of a homozygous DNase-1 null strain and a wild type strain (Table 2.2 and Figure 2.3) were made to examine the distributions of DNase-1 and Acph-1 activities in the subcellular fractions of embryonic

Table 2.2 Mean relative activities of DNase-1 and acid phosphatase-1 in subcellular fractions of embryonic cells from two strains of Drosophila melanogaster.

STRAINS	ENZYME ACTIVITIES*					
	<u>DNase-1</u>			<u>Acph-1</u>		
	LP	SP	S	LP	SP	S
BV1	13.6 (<u>+8.4</u>)	46.1 (<u>+3.1</u>)	40.3 (<u>+5.3</u>)	39.4 (<u>+4.1</u>)	29.5 (<u>+7.9</u>)	31.1 (<u>+3.8</u>)
<u>DNase-1</u> ^{n324/n324}	0.0 (<u>+0.0</u>)	0.0 (<u>+0.0</u>)	0.0 (<u>+0.0</u>)	46.7 (<u>+6.2</u>)	25.7 (<u>+5.1</u>)	27.6 (<u>+1.1</u>)

* Values in parentheses are the ranges of two determinations for each fraction.

Figure 2.3 DNase-1 (panel A), and Acph-1 (panel B) activities in the large particulate (LP), small particulate (SP), and soluble (S) fractions of embryonic cells from BV1, DNase-1ⁿ³²⁴, and Acph-1ⁿ¹³ strains of Drosophila melanogaster.

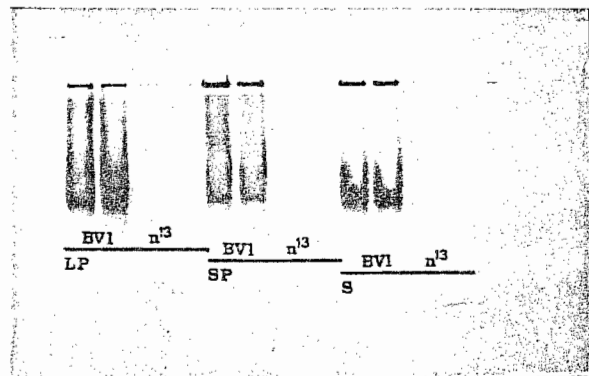
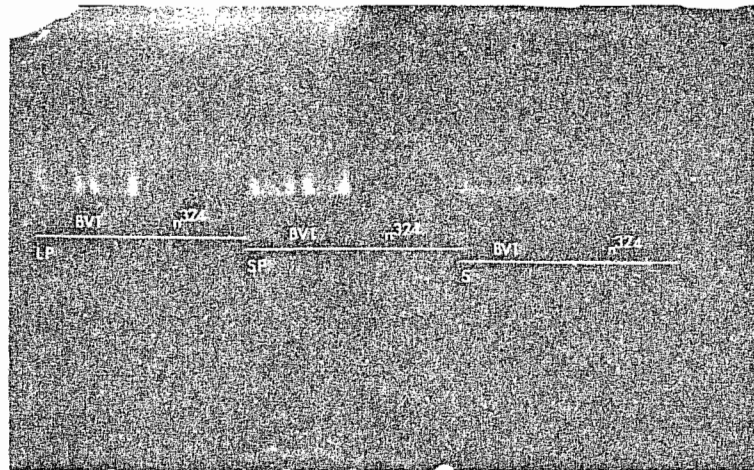

tissue. Densitometric data shown in Table 2.2 indicate that DNase-1 and Acph-1 activity distributions are similar to the distributions of total acid DNase and acid phosphatase activities reported in Table 2.1. DNase-1 activity is the highest in the SP fraction. However, in the same electrophoretic system, subcellular fractions of embryos homozygous for the null activity allele, DNase-1ⁿ³²⁴ exhibit a complete absence of DNase-1 activity from all subcellular fractions. Similar results were obtained for acid phosphatase-1 activity when a strain of embryos homozygous for the null allele, Acph-1ⁿ¹³, was used. Thus, it is probable that in the SP fraction with its relatively high specific acid DNase activity, most of the total acid DNase activity is contributed by the DNase-1 gene product.

Density Gradient Analysis of Acid DNase and DNase-1 Activity.

The small particulate fractions of embryos of a wild type strain (BV1) were subjected to equilibrium density gradient centrifugation in order to determine the distribution of acid phosphatase and acid DNase activities within the gradients. Since acid-phosphatase-1 has a lysosomal location in embryonic tissue (Sawicki and MacIntyre, 1977), acid DNase activity might be expected to equilibrate at a density similar to that of acid phosphatase activity in these gradients, if the acid DNase activity is also lysosomal in embryonic tissue. Results of a typical gradient experiment are shown in Figure 2.4. Although acid DNase activity is distributed throughout the gradient, its peak activity coincides with that of acid phosphatase. Both enzyme activity peaks lie near the

Figure 2.4 Distributions of acid DNase activity, acid phosphatase activity and total protein in a sucrose density gradient of the small particulate (SP) fraction of a homogenate of embryonic tissue. Embryoes were derived from the BV1 wild type strain of Drosophila melanogaster. Protein was determined by the Lowry (1951) method. Sucrose density was determined as described in Materials and Methods.

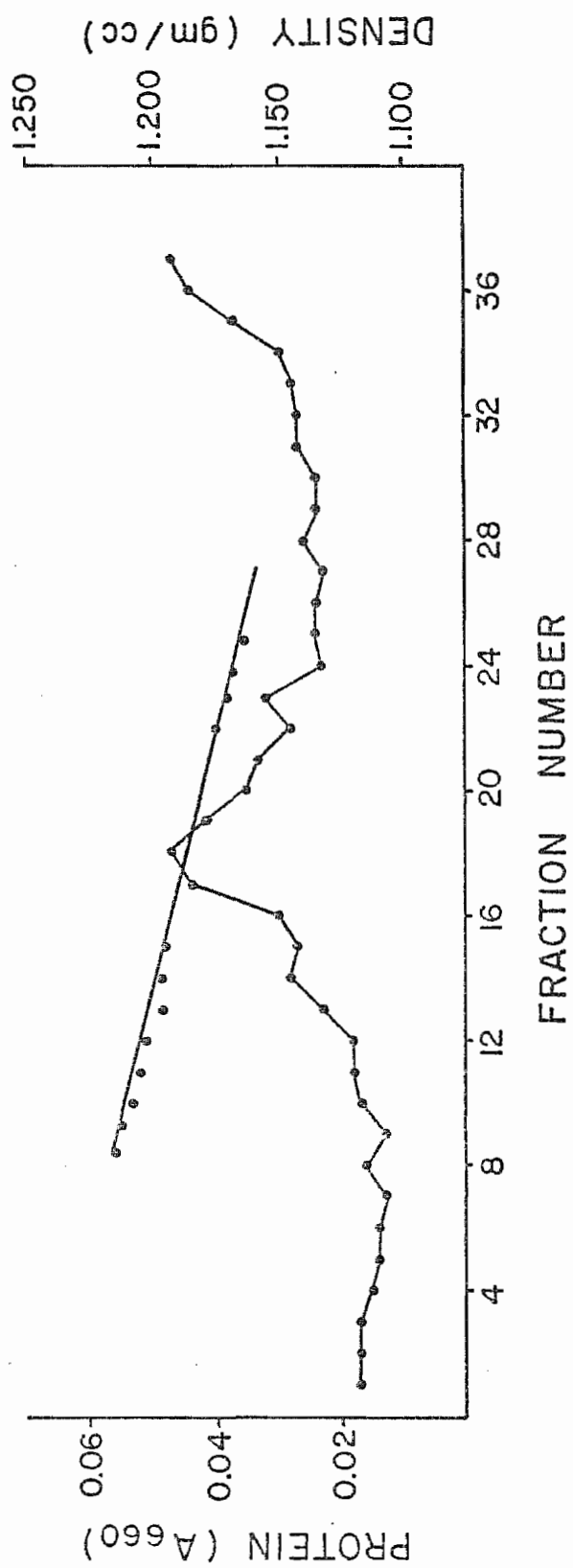
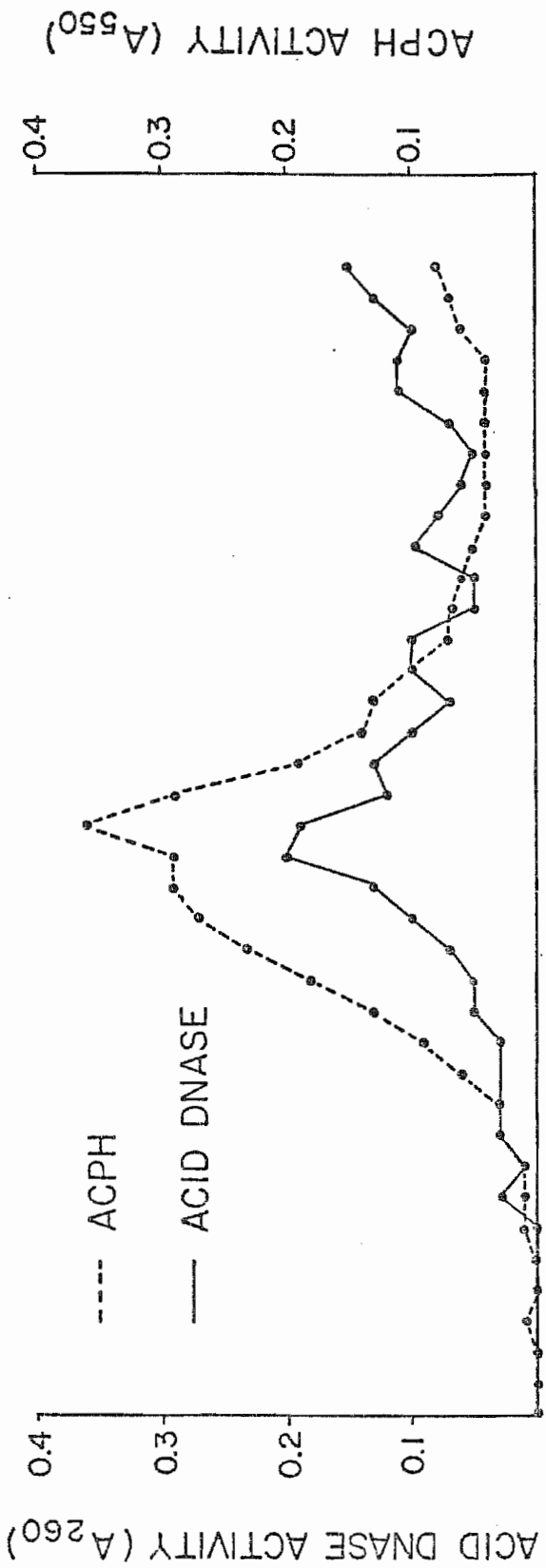

peak protein fraction in the gradient. The presence of maximal succinic dehydrogenase activity in this region of the gradient (Detwiler, unpublished observation) and the density range across the protein peak ($\rho = 1.200 - 1.175$) suggest that these fractions represent the equilibrium position of the mitochondrial fraction. It is worth noting that the equilibrium position of mitochondria and lysosomes in sucrose gradients of rat liver tissue are within 0.02 gm/ccm of each other (Beaufay, 1964). On this basis, overlap of the mitochondrial and lysosomal distributions in these gradients would be expected. The sucrose density in the vicinity of maximal enzyme activity for acid phosphatase and acid DNase is $\rho = 1.185 - 1.187$ gm/cc. This range of density is very similar to the average density ($\rho = 1.19$ gm/cc) reported for rat spleen lysosomes (Bowers et al., 1967) and to the average density at which Henrikson and Clever (1972) found acid phosphatase and acid protease in sucrose gradients of extracts from the salivary glands of Chironomus. Thus, the sucrose density at which acid DNase activity equilibrates and the coequilibration of acid DNase and acid phosphatase activities are observations which strongly suggest that much of the acid DNase activity in Drosophila embryonic tissue is lysosomal. Increases in enzyme activity and total protein at the top of the gradients probably result from disruption of particulate material during resuspension of the SP pellet.

When 40 μ l aliquots from selected fractions of the gradients are subjected to acrylamide gel electrophoresis, acid phosphatase-1

and DNase-1 gene products are distributed as indicated in Figure 2.5. In gels, DNase-1 activity was observable in fractions 16, 19 and 22, but intervening fractions presumably contain DNase-1 activity as well. These fractions correspond to the peak of acid phosphatase-1 activity as well as the peak of total acid DNase and acid phosphatase activities. This result is consistent with the earlier observation that most of the total acid DNase activity is contributed by DNase-1.

Finally, when SP fractions of embryos from the homozygous null strain DNase-1ⁿ³²⁴ are subjected to density gradient analysis, the lysosomal fraction of the gradient, as determined by the peak of acid phosphatase activity, contains no DNase-1 activity (Figure 2.6). Conversely, when SP fractions from embryos of the AcpH-1ⁿ¹³ null strain are used, the lysosomal fraction as determined by the peak of acid DNase activity, contains no acid phosphatase-1 activity (Figure 2.6). These results show that a region of the density gradient, in which acid phosphatase containing particles (lysosomes) are localized, contains no DNase-1 activity in the DNase-1ⁿ³²⁴ strain.

Taken together, the above results indicate that the DNase-1 locus in Drosophila melanogaster contributes a gene product that is localized within the lysosomes of developing embryos. This location within lysosomes suggests a degradative function for DNase-1. That DNase-1 is utilized in degradation of total cellular DNA is also suggested by its increased activity during pupation (Detwiler

Figure 2.5 Cosedimentation of DNase-1 and Acph-1 in a sucrose density gradient. SP pellets from the BV1 wild type strain were subjected to density gradient centrifugation as described in Materials and Methods section. Gradients were fractionated and frozen. 40 ul aliquots (DNase-1) or 15 ul aliquots (Acph-1) were subjected to electrophoresis in acrylamide gels. DNase-1 and Acph-1 activity in gels were scanned on a densitometer; peaks were cut out and weighed. Heights of bars represent intensities of enzyme activity as determined from peak heights. Fractions from the gradient selected for electrophoresis are indicated above the bars.

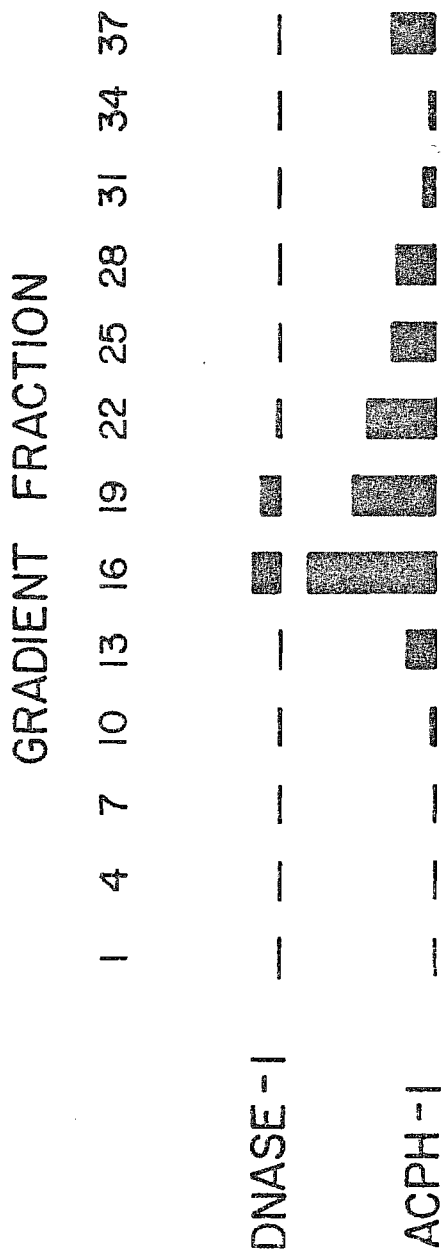

Figure 2.6 Peak fractions of DNase-1 and Acph-1 activities from sucrose density gradients of the small particulate fraction from embryonic cells of the BV1, DNase-1ⁿ³²⁴, and Acph-1ⁿ¹³ strains of Drosophila melanogaster. TSS/Pr designates DNase-1 activity from extracts of adult individuals from a strain used in the genetic localization of the DNase-1 structural gene. Ten peak fractions for each strain were concentrated to 125 ul, and samples of the concentrated material were subjected to electrophoresis as described in Materials and Methods.

BV1

n³²⁴

n¹³

TSS/Pr



BV1



n³²⁴

n¹³

and MacIntyre, 1978), a time of extensive tissue histolysis. Further studies of the substrate specificities of DNase-1 will be useful in defining the role of this enzyme in insect development.

BIBLIOGRAPHY

- Anastasia-Sawicki, J. and R. J. MacIntyre (1975). Ultrastructural histochemical localization of acid phosphatase in salivary glands of D. melanogaster. J. Histochem. Cytochem. 24, 463-467.
- Barret, A. J. (1972). Lysosomal Enzymes. In: Lysosomes, A Laboratory Handbook, Ed. by J. T. Dingle. North Holland Publishing Co., Amsterdam.
- Beaufay, H. (1972). Methods for the Isolation of Lysosomes. In: Lysosomes, A Laboratory Handbook, Ed. by J. T. Dingle. North Holland Publishing Co., Amsterdam.
- Beaufay, H., Jacques, P., Baudhuin, P., Sellinger, O., Berthet, J., and C. DeDuve (1964). Tissue Fractionation Studies 18. Resolution of mitochondrial fractions from rat liver into three distinct populations of cytoplasmic particles by means of density equilibrium in various gradients. Biochem. J. 92, 184-205.
- Bell, J. B., MacIntyre, R. J. and A. P. Olivieri (1972). Induction of null activity mutants for the acid phosphatase-1 gene in D. melanogaster. Biochem. Genet. 6, 205-216.
- Bell, J. B. and R. J. MacIntyre (1973). Characterization of acid phosphatase-1 null activity mutants of Drosophila melanogaster. Biochem. Genet. 10, 39-56.
- Bernardi, G. (1971). Spleen Acid Deoxyribonuclease. In: The Enzymes, Ed. by P. Boyer. Academic Press, New York.
- Bowers, W. E. and C. DeDuve (1967). Lysosomes in Lymphoid Tissue II. Intracellular distribution of acid hydrolases. J. Cell Biol. 32, 339-348.
- Boyd, J. B. and H. K. Mitchell (1965). Identification of deoxyribonucleases in polyacrylamide gel following their separation by disc electrophoresis. Anal. Biochem. 13, 28-42.
- DeDuve, C., Pressman, B., Gianetto, R., Wattiaux, R., and F. Applemans (1955). Tissue Fractionation Studies 6. Intracellular distribution patterns of enzymes in rat liver tissue. Biochem. J. 60, 604-617.
- Detwiler, C. R. (1979). Thesis. A genetic and developmental analysis of DNase-1, an acid deoxyribonuclease in Drosophila melanogaster. Cornell University, Ithaca, N. Y.

- Detwiler, C. R. and R. J. MacIntyre (1978). A genetic and developmental analysis of an acid deoxyribonuclease in Drosophila melanogaster. Biochem. Genet. 16, 1113-1138.
- Henrikson, P. and U. Clever (1972). Protease activity and cell death during metamorphosis in the salivary gland of Chironomus tentans. J. Insect Physiol. 18, 1981-2004.
- Hildreth, P. E. and C. Brunt (1962). Method for collecting large numbers of fertilized Drosophila melanogaster eggs in meiotic stages. Drosophila Inform. Serv. 36, 128-129.
- Kriegstein, H. and D. S. Hogness (1974). Mechanism of DNA replication in Drosophila chromosomes. Structure of replication fork and evidence for bidirectionality. Proc. Nat. Acad. Sci. 71, 135-139.
- MacIntyre, R. J. (1966). The genetics of an acid phosphatase in Drosophila melanogaster and Drosophila simulans. Genetics 63, 461-474.
- MacIntyre, R. J. (1971). A method for measuring the activities of acid phosphatases separated by acrylamide gel electrophoresis. Biochem. Genet. 5, 45-54.
- Novikoff, A. B. (1961). Lysosomes and related particles. In: The Cell, vol. 2, Ed. by J. Brachet and A. Mirsky. Academic Press, New York.
- O'Brien, S. J. and R. J. MacIntyre (1972). The α -glycerophosphate cycle in Drosophila melanogaster, I. Biochemical and Developmental Aspects. Biochem. Genet. 7, 141-162.
- Sacktor, B. J. and D. G. Cochran (1957). DPN - specific α -glycerophosphate dehydrogenase in insect flight muscle. Biochim. Biophys. Acta 25, 649.
- Sawicki, J. (1976). Thesis. An ultrastructural histochemical study of acid phosphatase-1 activity during oogenesis and embryogenesis in Drosophila melanogaster. Cornell University, Ithaca, N. Y.
- Sawicki, J. and R. J. MacIntyre (1977). Synthesis of acid phosphatase-1 in the ovary of Drosophila melanogaster. Develop. Biol. 60, 1-13.
- Slor, H. and T. Lev (1971). Acid deoxyribonuclease activity in purified calf thymus nuclei. Biochem. J. 123, 993-995.

Chapter 3

A DEVELOPMENTAL ANALYSIS OF THE EXPRESSION OF WILD TYPE
AND NULL ALLELES OF THE DNASE-1 LOCUS OF DROSOPHILA
MELANOGASTER.

Introduction

Acid deoxyribonucleases (E. C. 3.1.4.6.) are a class of enzymes which, under conditions of acid pH, hydrolyze DNA to oligonucleotides. In vertebrates, they are present in a variety of epithelial and lymphatic tissues, tumors and cells such as erythrocytes and sperm. Their presence has also been documented in invertebrates and protozoans (Bernardi, 1971; Eeckhout, 1973; and Aaronson, 1973). In higher organisms, the mechanism of substrate degradation (Soave et al., 1973) and a generalized lysosomal location (Barret, 1972) suggest that acid DNases function in the degradation of cellular or foreign DNA with a reuse of the degradation products by the organism for the biosynthesis of nucleic acids. In this regard acid DNases are believed to have a primarily digestive role (Eeckhout, 1973; Aaronson, 1973) within secondary lysosome-like structures.

In many of the systems where acid DNase is best understood biochemically, genetic analysis is lacking. Drosophila melanogaster is a desirable system for studying the biological functions of DNases because of its genetic tractability, its status as a higher eukaryote, and its usefulness in enzymological studies (O'Brien and MacIntyre, 1978). In addition, null activity mutants have been generated with relative ease in Drosophila melanogaster (O'Brien and MacIntyre, 1978) in a number of gene enzyme systems. This makes it feasible to use a genetic approach to the question of the biological function of a given enzyme.

Using an electrophoretic assay for DNase activity (Boyd and Mitchell, 1965), Boyd has examined the developmental profiles of the major deoxyribonucleases of Drosophila (Boyd, 1969). Recently, we have investigated the properties of the major soluble acid deoxyribonuclease in Drosophila melanogaster. The presence of electrophoretic variants has enabled us to locate the structural gene for the enzyme, DNase-1, which is on the third chromosome between the recessive mutants sr and bx at 61.8 (Detwiler and MacIntyre, 1978; see Lindsley and Grell, 1968, for a description of sr and bx). The locus has also been placed between 90C-2 and 90E on the salivary chromosome map. Eight null activity alleles have been generated at the DNase-1 locus using EMS as a mutagen. Strains homozygous for these null alleles exhibit very little total acid DNase activity when compared with wild type strains; yet they are viable and fertile (Detwiler, 1979). Differential centrifugation studies and sucrose gradient analyses of homogenates of embryos suggest that the enzyme is present in lysosomes (Detwiler and MacIntyre, 1979). A lysosomal location for DNase-1 is also suggested by its acid pH optimum and latency of activity in extracts (Detwiler, 1979). DNase-1 shares these characteristics with acid phosphatase-1 (Yasbin, 1970) which is known to be a lysosomal enzyme by ultrastructural histochemical analyses. (Sawicki and MacIntyre, 1977). The evidence that DNase-1 in Drosophila melanogaster is a lysosomal enzyme strongly suggests that it participates in the degradation and turnover of cellular DNA.

The purpose of this study is to further characterize the function of the DNase-1 gene product by means of an examination of its activity profile during development, and through an analysis of the effects of homozygosity for a DNase-1 null allele on the length of the life cycle and on female fecundity. The distribution of DNase-1 activity in the major segments of adults is also examined.

Materials and Methods

Developmental Analysis.

Three strains were used in the developmental analysis: DNase-1^C/DNase-1^C, DNase-1^A/DNase-1^A and DNase-1^{lmh} (see Detwiler and MacIntyre, 1978, for details). A wild type strain, BV1, from Blacksburg, Virginia (kindly provided by Dr. Bruce Wallace) was homozygous for the DNase-1^A allele. The recessive visible strain gl (glass, 3-63.1; Lindsley and Grell, 1968), obtained from the Mid-America Drosophila Stock Center, was homozygous for the DNase-1^C allele. The low activity strain, DNase-1^{lmh}, and the deficiency for the DNase-1 locus, Df(3R)P14/T(2;3)ap^{Xa} (Detwiler and MacIntyre, 1978) were a gift from Mr. Jim Stone. DNase-1ⁿ³³⁴ and DNase-1ⁿ³²⁴ strains are homozygous for, respectively, low activity and null activity alleles of the DNase-1 locus (Detwiler, 1979). Also used was a strain of flies homozygous for the third chromosome markers e ca AcpH-1ⁿ¹³ by (see Lindsley and Grell, 1968; and Bell et al., 1972). The DNase-1ⁿ³²⁴ strain was derived from this strain by EMS mutagenesis.

Egg collections were made according to a modification of the method described previously by Yasbin (1970). Virgin females were stored for two to five days at 24°C in shell vials on a standard cornmeal-molasses medium topped with dry yeast to discourage oviposition. Males were stored in vials for two or three days at 24°C. Approximately 40 females or 40 males were stored per vial. Males and females were combined in egg-laying chambers described by Hildreth and Brunt (1962). Eggs laid during the first 24 hours were discarded to reduce the frequency of "retained embryos" (Sonnenblick, 1950). The acid DNase patterns of staged embryos as well as first, second, third instar larvae, pupae and one day old adults were analyzed in gels. Each pocket contained an extract of either: 80 embryos, 20 first instar larvae, 10 second instar larvae, or single individuals from later developmental stages. The fractionated heads, thoraces, and abdomens of adults were also analyzed by gel electrophoresis.

Life Cycle Duration and Fecundity Determination.

Determinations of the length of the life cycle were carried out in shell vials on standard cornmeal-molasses medium topped with a live yeast suspension at 25° ± 1°C. The medium used to collect staged embryos was that of Kriegsten et al. (1974) except that grape juice was omitted and Norit A was added until the media was black. Analyses were performed at 25° ± 1°C at high humidity on a single preparation of egg laying media. All transfers of flies were made using CO₂ anaesthesia.

Results

Development Profile of DNase-1.

Two developmental profiles of DNase-1 activity in DNA-acrylamide gels are shown in Figure 3.1. One is of heterozygous individuals from a cross between homozygous DNase-1^C/DNase-1^C females and DNase-1^A/DNase-1^A males and the other profile represents individuals from a cross between females homozygous for a DNase-1 allele of low activity (DNase-1^{lmh}) and males homozygous for the DNase-1^A allele (Detwiler and MacIntyre, 1978). DNase-1^{lmh} has an electrophoretic mobility identical with DNase-1^C and lies within Df(3R)P14 (J. Stone, personal communication; Detwiler, 1979). On this basis it appears to be an allele of the DNase-1 locus. Despite the absence of the maternal gene product in the progeny of the second cross (B), it is evident that fluctuations of DNase-1 activity levels through development are similar for individuals from either cross. In early embryonic development, DNase-1 is present at 0-1 hours after fertilization with the maternal gene product in excess of the paternal gene product (A-1,2). However, in embryos having a low-activity maternal gene product (not visible in gel until stage B-9), the paternal gene product is present and functioning at 0-1 hours after fertilization. After the first few hours of embryonic development, DNase-1 activity apparently decreases, then rises again at about 8-9 hours after fertilization, at a time when gastrulation is completed and head segment invagination and segmentation are occurring (Bownes, 1975). By 15-16 hours after fertilization, activity has

Figure 3.1 Two profiles of the ontogeny of DNase-1. Profiles A and B represent staged progeny of the crosses indicated, where A and C are alleles of DNase-1. C^1 is the DNase-1^{lmh} allele. Stages are as follows: 1, 0-1 hr embryos; 2, 2-3 hrs; 3, 4-5 hrs; 4, 6-7 hrs; 5, 8-9 hrs; 6, 15-16 hrs; 7, 1st instar larvae; 8, 2nd instar larvae; 9, 3rd instar larvae; 10, prepupa; 11, early pupa; 12, late pupa; 13, adult. For numbers of individuals per pocket, see Materials and Methods section.

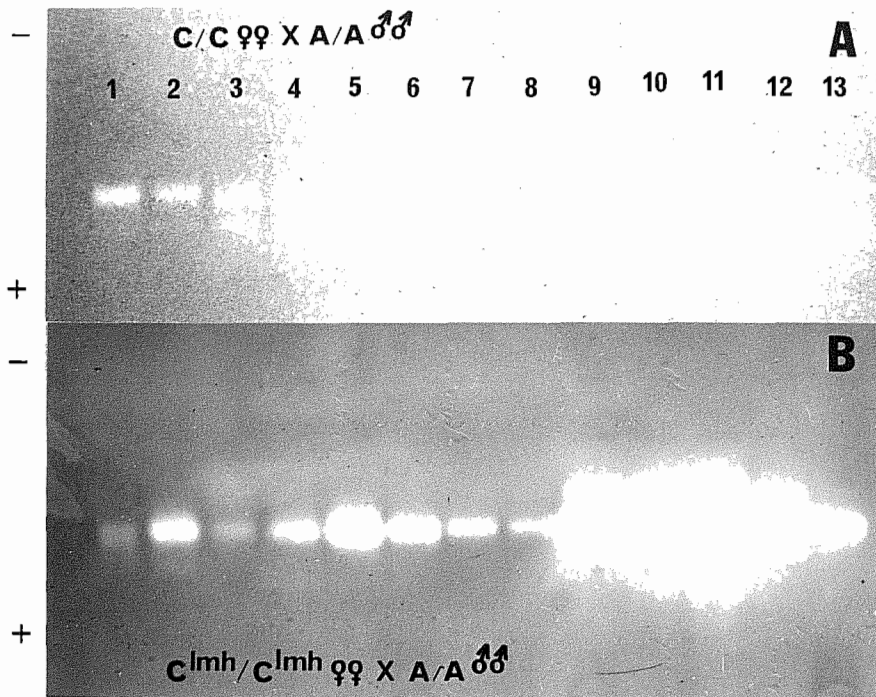

again decreased and remains relatively low through the first instar and into the second instar larval stages. Although relative amounts of adult and larval enzyme are not strictly comparable due to the absence of wet weights of individual samples, some further generalizations are possible. It appears that during the third larval instar stage, activity increases dramatically and remains quite high during pupation, a period of extensive tissue histolysis. Following eclosion, there is a rapid decrease in activity in adults.

During the second larval instar, an additional zone of activity appears ahead of the A and C zones common to all other stages. This activity disappears by the late pupal stage, indicating that it is specific to late larval and pupal stages. The activity in A/A and C/C homozygotes migrates just ahead of the main band, which suggests that it results from a stage specific modification of the major product of the DNase-1 locus. A similar modification relationship has been observed among the isozymes of α -GPDH in Drosophila melanogaster (Wright and Shaw, 1969). Nothing is yet known concerning possible tissue specificity of this activity.

In an effort to examine tissue specificity of the DNase-1 gene product a little more precisely, female and male adult flies were separated into head, thorax, and abdominal regions, and approximately equal quantities of each segment were assayed electrophoretically for DNase-1 activity. Soluble activities showed no reproducible differences in amount of activity with respect to either sex or body region. Activity near the origin was present in both sexes in extracts of thoraces and abdomens but not in

extracts of heads. These results suggest either a generalized distribution of DNase-1 activity with respect to body regions of the adult or localization to a specific tissue common to all body parts (e.g., the hypodermis).

Effect of DNase-1 Null Alleles On Development.

A series of six strains of Drosophila melanogaster, (Oregon R, Canton S, BV1, DNase-1^{1mh/1mh}, DNase-1^{n334/n334}, DNase-1^{n324/n324}) were cultured under identical conditions of humidity, temperature, and nutrients in order to compare the average duration of the life cycle for each strain. Based on comparisons in DNA-acrylamide gel assays (Boyd and Mitchell, 1965), Oregon R and Canton S laboratory strains have what can be considered as wild type amounts of DNase-1 activity. BV1 apparently has more DNase-1 activity at 25°C (Detwiler and MacIntyre, 1978) than Canton S and Oregon R. DNase-1^{1mh/1mh} and DNase-1^{n334/n334} strains have low activity, whereas DNase-1^{n324/n324} has virtually no DNase-1 activity. One-day old females and males from each strain were placed in vials (6 males and 6 females per vial) and their offspring were allowed to develop at 25 ± 1°C as described in Materials and Methods. The times at which the offspring reached each developmental stage were recorded and the results are shown in Table 3.1. Observations were made at approximately the same time each day. Each reported value is the mean of the indicated number of separate determinations; the values in parentheses are ranges. The results indicate that a significant decrease (n^{1mh}, n³³⁴) or virtual absence (n³²⁴)

Table 3.1 Time in days required to reach various developmental stages for the individuals from several strains of Drosophila melanogaster. For each mean value the range of values for all determinations is indicated in parentheses.

<u>strain</u>	<u>number of determinations</u>	<u>1st instar</u>	<u>3rd instar</u>	<u>1st pupa</u>	<u>1st adult</u>	<u>10 adults/vial</u>
Oregon R	6	2.0 (<u>+0.0</u>)	4.6 (<u>+0.5</u>)	6.4 (<u>+0.5</u>)	9.4 (<u>+1.0</u>)	11.8 (<u>+0.5</u>)
Canton S	6	2.0 (<u>+0.0</u>)	4.8 (<u>+0.5</u>)	6.2 (<u>+0.5</u>)	11.0 (<u>+0.0</u>)	12.0 (<u>+0.0</u>)
BV1	10	2.0 (<u>+0.5</u>)	4.8 (<u>+0.5</u>)	6.8 (<u>+1.5</u>)	10.4 (<u>+1.0</u>)	12.2 (<u>+1.5</u>)
1mh/1mh	18	2.0 (<u>+0.0</u>)	5.0 (<u>+1.0</u>)	6.3 (<u>+0.5</u>)	11.0 (<u>+1.5</u>)	11.9 (<u>+0.5</u>)
n ³³⁴ /n ³³⁴	3	3.0 (<u>+0.0</u>)	5.0 (<u>+0.0</u>)	6.0 (<u>+0.0</u>)	10.0 (<u>+0.0</u>)	12.0 (<u>+0.0</u>)
n ³²⁴ /n ³²⁴	10	2.0 (<u>+0.0</u>)	4.8 (<u>+0.0</u>)	6.6 (<u>+0.5</u>)	10.0 (<u>+1.0</u>)	12.2 (<u>+0.5</u>)

Table 3.1

of the DNase-1 gene product has no significant effect on the duration of the life cycle. The times required to reach the onset of the various stages are also quite similar in all strains, with the possible exception of the time of egg hatching in the n^{334} strain. The small sample size for the n^{334} strain make the difference in hatching time of questionable significance, however.

Since there is considerable evidence (King, 1970) that many macromolecular constituents of nurse cells including DNA are degraded and transported to developing oocytes, two experiments were designed to demonstrate possible effects of the absence of DNase-1 activity on fecundity. The parameters of fecundity examined were: 1) the time of onset of egg laying in newly emerged females and 2) the rate of egg laying in 6-10 day old females.

In order to determine the times at which egg laying begins, newly emerged males and females from three strains of flies: BV1, DNase-1^{n324/n324}, and e ca Acph-1ⁿ¹³ by, were maintained for 19 hours on heavily yeasted media in vials. For each strain, five or six replicate vials were set up with five females and ten males per vial. After the initial feeding period the flies were then transferred to freshly yeasted vials at intervals of from six to twelve hours. The number of embryos oviposited in each vial was used to calculate cumulative numbers of embryos produced per female by the end of each collection interval. As can be seen in Figure 3.2 the three strains differ with regard to the onset of egg laying. In addition, the rate of embryo production is

Figure 3.2 Cumulative numbers of embryos produced per female from 28 to 70 hours after eclosion for three strains of Drosophila melanogaster. Vertical bars represent ranges of values. The genotypes of the three strains are described in Materials and Methods.

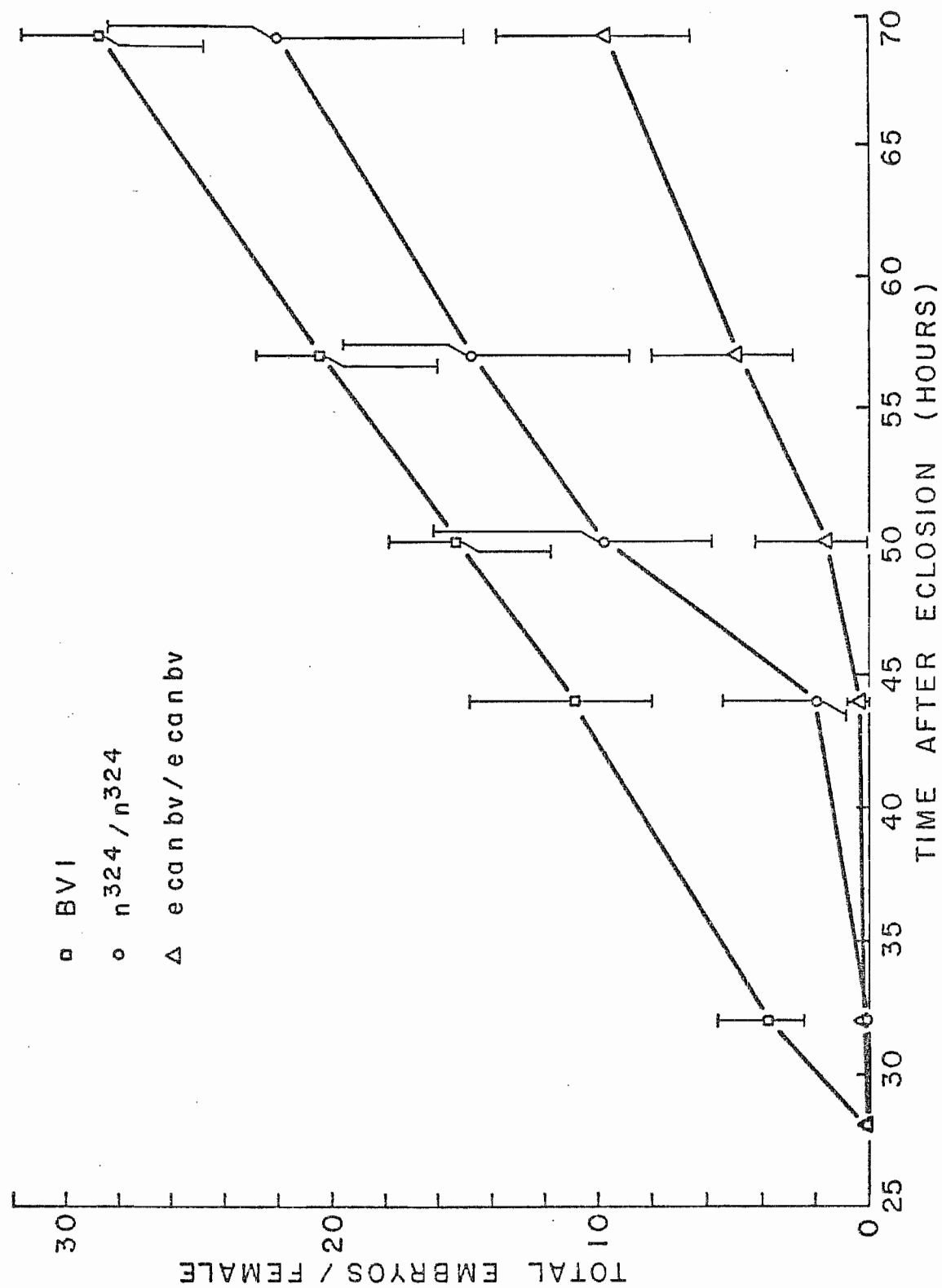

higher in the wild type BV1 strain than in the other two strains until about 50 hours after eclosion, when the three rates become very similar. Females from both the DNase-1ⁿ³²⁴ strain and the strain from which it was derived by EMS mutagenesis (e ca Acph-1ⁿ¹³ by) produce virtually no eggs for the first 32 hours after emergence and oviposit very few eggs, by comparison with BV1, until 44 hours. After 32 hours, cumulative egg production for the DNase-1ⁿ³²⁴ strain remains intermediate between those of the wild type strain and the mutagenized strain from which the DNase-1 null strain was derived.

A second analysis of the fecundity of the three strains was made by comparing rates of egg production in 6-10 day old females. During this time wild type females typically exhibit maximum egg production (Ashburner and Thompson, 1978). For each strain 40 flies (20 females and 20 males, 0-4 days old) were placed into each of five heavily yeasted vials. On the third day flies were transferred to new heavily yeasted vials for three more days. On the sixth day flies were transferred without anaesthesia to egg laying chambers which were placed on the surface of the egg laying medium. New egg laying medium was substituted every two hours for five consecutive egg collection periods. For each strain, the numbers of embryos on the media and the numbers of females recovered from the chambers were used to estimate egg output per female for each egg laying period in each of the chambers. Outputs for each strain were averaged first over the five collection periods and then over the five replicate laying chambers. Mean oviposition rates and

their standard deviations are given for each strain in Table 3.2. Rate of oviposition is similar for the BV1 wild type strain and the mutagenized e ca Acph-1ⁿ¹³ by strain, but is significantly greater in the DNase-1ⁿ³²⁴ strain. Since the genetic backgrounds of the DNase-1ⁿ³²⁴ and e ca Acph-1ⁿ¹³ by strains are different, the increased fecundity of the DNase-1ⁿ³²⁴ strain cannot be causally associated with either the loss of acid DNase activity or the loss of third chromosome markers in the mutagenized stock. However the results do suggest that the loss of DNase-1 activity does not itself result in a decrease in the rate of embryo production.

Discussion

DNase-1 activity is present during all stages of the life cycle of Drosophila melanogaster. The precise intracellular function of DNase-1 at any point in development can in principle be determined from a study of the phenotypic effects of null mutants. Several putative null mutants have been obtained but, thus far, all have shown slight activity on gels during the pupal stage suggesting that an "absolute" or non-leaky null has yet to be produced. However, the results obtained above using available mutants together with the developmental profile of DNase-1 activity in wild type strains suggest several possible functions for DNase-1 at various stages of the life cycle. During early embryogenesis the embryo contains more maternally derived DNase-1 gene product than that produced by the embryo itself (see Figure 3.1). The gene product of the paternal allele however is present in embryos at

Table 3.2 Oviposition rate for three strains of Drosophila melanogaster.

<u>STRAIN</u>	<u>RATE (embryo/hr./individual)</u>		
	<u>Mean</u>	<u>S.D.</u>	<u>Number of Determinations</u>
BV1	2.45	(<u>+1.57</u>)	25
n ³²⁴	5.35	(<u>+1.09</u>)	25
<u>e ca Acph-1</u> ⁿ¹³ <u>bv</u>	2.34	(<u>+0.53</u>)	25

0-1 hours after fertilization suggesting that transcription of the paternal genome occurs almost immediately after fertilization takes place. To our knowledge, no other gene-enzyme system in Drosophila shows activation of the paternal allele this early in development. Assuming that some time is required for transcription, m-RNA processing, movement of the message to the cytoplasm, and translation of the message in ribosomes, transcription of the paternal allele probably commences almost immediately after entry of the sperm nucleus into the egg.

What function(s) might DNase-1 have during embryogenesis? Muckenthaler and Mahowald (1966) estimate that at least 36% of the oocyte's DNA is cytoplasmic but not mitochondrial. They suggest this may be a "storage" DNA necessary to provide precursors for the DNA synthesis accompanying the rapid nuclear proliferation in early embryogenesis. Possibly DNase-1 is involved in the production of these nucleotide precursors.

During larval development, the activity of DNase-1 increases with each instar, although the larval activity is not as great as that of pupal extracts. In this respect, the developmental profile of DNase-1 activity as shown in Figure 3.1 exhibits some differences from that reported by Boyd (1969). His results suggest there is greater enzyme activity (in the presence of native DNA as a substrate) during larval development (87 hours after oviposition) than during pupation. This may be due to differences in the preparation of homogenates. Boyd (1969) prepared homogenates from unfrozen flies just prior to electrophoresis and centrifuged

at 75,000 x g for 15 minutes to remove debris. Our homogenates were prepared the day before the electrophoretic analysis and frozen overnight. We have found that freezing and thawing increases acid DNase activity. Prior to electrophoresis, our samples are spun for ten minutes at only 13,000 x g to remove debris.

The developmental profile of DNase-1 suggests that it is particularly important during pupation. Studies of the distribution of DNase-1 under differing conditions of homogenization suggest that the hypotonic buffer in which the samples for the developmental profile were prepared released virtually all of the DNase-1 activity into the soluble fraction (Detwiler, 1979). Therefore the dramatic increase in DNase-1 activity observed in gels probably reflects an increased synthesis of DNase-1 during pupation and not merely an increase in the lability of pupal lysosomes. This increase in activity during pupation is similar to activity patterns observed for Drosophila acid phosphatase (Yasbin et al., 1978), β -galactosidase (D. Knipple, personal communication), α -fucosidase (Repp, 1977) and leucine amino peptidase (Sakai et al., 1969), all of which are mammalian lysosomal enzymes (Barret, 1972). This general increase in the putative lysosomal enzyme activities together with the observation that lysosomes contain all the enzymes necessary to degrade nucleic acids to nucleosides (Bernardi, 1971) strongly suggests that the function of DNase-1 during pupation is the degradation of cellular DNA in tissues undergoing histolysis.

How critical to viability is the function of pupal DNase-1? The egg to adult developmental times for strains homozygous for two different null alleles at the DNase-1 locus (n^{334} , n^{324}) are not significantly longer than those of three wild type strains. It should be stressed that these strains are not coisogenic, and small differences in life cycle length would not be detected with our sampling system. The results do suggest, however, that the presence of null activity alleles at the DNase-1 locus does not significantly lengthen the life cycle as do, for example, the Minute mutations (Brehme, 1942). That is to say, the time required for pupation is not greatly affected by significant decreases in the amount of DNase-1 activity. It is possible that very small amounts of DNase-1 or another acid DNase present in the null strains may be sufficient to allow development to continue at a normal rate.

Insect lysosomal enzymes have been implicated in several "maintenance" functions within adult tissues (Lockshin, 1969), but the specific role of acid DNases has not been examined. As suggested above, one possible function of Drosophila DNase-1 in adult females may be the degradation of nurse cell DNA during oogenesis. One phenotype of the low activity mutant DNase-1^{lmh} (which is probably a DNase-1 allele) is an intense Feulgen-positive staining of nurse cell nuclei (J. Stone, personal communication), suggesting the presence of undegraded DNA which is not present in wild type nurse cell nuclei. Although this observation provides some indirect evidence that DNase-1 functions during oogenesis in

Drosophila, homozygosity for a null allele at the DNase-1 locus has no effect on fecundity in terms of either delay of the onset of oviposition, or the rate of oviposition itself. Despite the fact that the three strains, BV1, DNase-1ⁿ³²⁴, and e ca Acph-1ⁿ¹³ by are not coisogenic, the comparisons between them argue that the rate of oviposition is certainly not decreased in the DNase-1ⁿ³²⁴ strain. Although the onset of fecundity in the DNase-1ⁿ³²⁴ strain is delayed relative to BV1, differences in the genetic backgrounds of the tested strains make it impossible to assign this effect to the absence of DNase-1 activity. The most meaningful comparison, that between the DNase-1ⁿ³²⁴ strain and the strain mutagenized to produce it, involves genetic heterogeneity introduced in the cross scheme used to select the mutants. The onset of egg production is sooner after emergence in the DNase-1^{n-324/n324} strain than in the mutagenized strain. This may, therefore, be due either to the loss of the third chromosome markers or to the replacement of other unidentified genes of the mutagenized strain. Further comparisons between other DNase-1 nulls and wild type strains must be made with coisogenic stocks in order to determine more precisely what effect the DNase-1 locus might have on the inception of oviposition.

Grell has determined (1976) that decreased DNase-1 activity in a DNase-1¹⁰ homozygote has no observable effect on recombination frequencies in Drosophila melanogaster females, suggesting that the enzyme is not involved in the molecular aspects of meiotic recombination.

The results presented in this study together with other observations cited above suggest that the function of DNase-1 is primarily the degradation of cellular DNA. More precise identification of the function(s) of DNase-1 may be attained after the induction of a (perhaps temperature sensitive) non-leaky mutant or, perhaps, by quantitative histochemical analysis of the lysosomes of existing DNase-1 null strains. An analysis of the substrate specificities of DNase-1 will also be useful in determining more precisely its role in insect development.

BIBLIOGRAPHY

- Aaronson, S., (1973). Digestion in Phytoflagellates. In: Lysosomes in Biology and Pathology, Ed. by J. T. Dingle. North Holland Publishing Co., Amsterdam.
- Ashburner, M. and J. N. Thompson (1978). The Laboratory Culture of Drosophila. In: The Genetics and Biology of Drosophila, Vol. 2a. Ed. by M. Ashburner and T. R. F. Wright. Academic Press, New York.
- Barret, A. J. (1972). Lysosomal Enzymes. In: Lysosomes, A Laboratory Handbook, Ed. by J. T. Dingle. North Holland Publishing Co., Amsterdam.
- Bell, J. B., MacIntyre, R. J. and A. P. Olivieri (1972). Induction of null-activity mutants for the acid-phosphatase-1 gene in Drosophila melanogaster. Biochem. Genet. 6, 205-216.
- Bernardi, G. (1971). Spleen Acid Deoxyribonuclease. In: The Enzymes, Ed. by P. Boyer. Academic Press, New York.
- Bownes, M. (1975). A photographic study of development in the living embryo of Drosophila melanogaster. J. Embryol. Exp. Morph. 33, 789.
- Boyd, J. B. (1969). Drosophila deoxyribonucleases. I. Variation of deoxyribonucleases in Drosophila melanogaster. Biochim. Biophys. Acta 171, 103.
- Boyd, J. B. and H. K. Mitchell (1965). Identification of deoxyribonucleases in polyacrylamide gel following their separation by disc electrophoresis. Anal. Biochem. 13, 28.
- Brehme, K. (1942). Development of the Minute phenotype in Drosophila melanogaster. A comparative study of the growth of three Minute mutants. J. Exptl. Zool. 88, 135-159.
- DeDuve, C. and H. Beaufay (1959). Tissue fractionation studies - Enzymic release of bound hydrolases. Biochem. J. 73, 604.
- Detwiler, C. R. (1979). Thesis. A genetic and developmental analysis of DNase-1, an acid deoxyribonuclease in Drosophila melanogaster. Cornell University, Ithaca, N. Y.
- Detwiler, C. R. and R. J. MacIntyre (1978). A genetic and developmental analysis of an acid deoxyribonuclease in Drosophila melanogaster. Biochem. Genet. 16, 1113-1138.

- Detwiler, C. R. and R. J. MacIntyre (1979). A subcellular localization of the DNase-1 gene product in embryos of Drosophila melanogaster. Manuscript in preparation.
- Eeckhout, Y. (1973). Digestion and Lysosomes in Zooflagellates. In: Lysosomes in Biology and Pathology, Ed. by J. T. Dingle. North Holland Publishing Co., Amsterdam.
- Grell, E. H. (1976). Genetics of some deoxyribonucleases of Drosophila melanogaster. Genetics 83, S28. Abstract.
- Hildreth, P. E. and C. Brunt (1962). Method for collecting large numbers of fertilized Drosophila melanogaster eggs in meiotic stages. Drosophila Inform. Serv. 36, 128-129.
- King, R. C. (1970). Ovarian Development in Drosophila Melanogaster. Academic Press, New York.
- Kriegstein, H. and D. S. Hogness (1974). Mechanism of DNA replication in Drosophila chromosomes. Structure of replication forks and evidence for bidirectionality. Proc. Nat. Acad. Sci. 71, 135-139.
- Lindsley, D. L. and E. H. Grell (1968). Genetic variation of Drosophila melanogaster. Carnegie Institute of Washington Publication No. 627.
- Lockshin, R. A. (1969). Lysosomes in Insects. In: Lysosomes in Biology and Pathology, Vol. 1. Ed. by J. T. Dingle and H. D. Fell. North Holland Publishing Co., Amsterdam.
- Muckenthaler, F. A. and A. P. Mahowald (1966). DNA synthesis in the ooplasm of Drosophila melanogaster. J. Cell Biol. 28, 199.
- O'Brien, S. J. and R. J. MacIntyre (1978). Genetics and Biochemistry of Enzymes and Specific Proteins of Drosophila. In: The Genetics and Biology of Drosophila, Ed. by M. Ashburner and T. R. F. Wright. Academic Press, New York.
- Repp, L. D. (1977). Thesis. Localization of the structural gene for α -L-fucosidase in Drosophila melanogaster. Cornell University, Ithaca, New York.
- Sakai, R. K., Tung, D. A. and J. G. Scandalios (1969). Developmental studies of aminopeptidases in Drosophila melanogaster. Molec. Gen. Genet. 105, 24-29.
- Sawicki, J. and R. J. MacIntyre (1977). Synthesis of acid phosphatase-1 in the ovary of Drosophila melanogaster. Develop. Biol. 60, 1-13.

- Soave, C., Thiery, J., Ehrlich, S. D. and G. Bernardi (1973). Kinetics of the middle and terminal phases of degradation of DNA by spleen acid DNase. *Evr. Jl. Biochem.* 38, 423-433.
- Sonnenblick, B. (1950). The early embryology of Drosophila. In: The Biology of Drosophila, Ed. by M. Demerec. Hafner, New York, 62-167.
- Wright, D. A. and C. R. Shaw (1969). Genetics and ontogeny of α -glycerophosphate dehydrogenase isozymes in Drosophila melanogaster. *Biochem. Gen.* 3, 313-353.
- Yasbin, R. (1970). Ontogeny and maternal effect of acid phosphatase-1 in Drosophila melanogaster. M.S. Thesis, Cornell University, Ithaca, New York.
- Yasbin, R., Sawicki, J. and R. J. MacIntyre (1978). A developmental study of acid phosphatase-1 in Drosophila melanogaster. *Devel. Biol.* 63, 35-46.

Appendix

PARTIAL PURIFICATION OF DNASE-1 FROM DROSOPHILA
MELANOGASTER.

PARTIAL PURIFICATION OF DNASE-1 FROM DROSOPHILA MELANOGASTER

This procedure was developed in order to isolate and purify DNase-1 from extracts of D. melanogaster pupae where it is found in relatively large amounts (Detwiler and MacIntyre, 1978). The assay for acid DNase activity has been described (Detwiler and MacIntyre, 1978). Protein was determined by the method of Lowry et al. (1951).

Frozen pupae (10% w/v) were homogenized at 0°C in H buffer (0.14 M NaCl, 0.02 M CaCl₂) using a 40 ml ground glass homogenizer (Ten Broek), such that no whole pupae remained. All further procedures were carried out at 0-4°C. The homogenate was brought to pH 2.5 with 0.10 M H₂SO₄ and stirred for ten minutes. The precipitate was centrifuged at 27,000 x g for 15 minutes in an SS-34 rotor of a Sorval RC-2B centrifuge, after which the pellet was discarded. Solid ammonium sulfate (Schwartz-Mann) was slowly added, with stirring, to 30% saturation (w/v). The precipitate was centrifuged at 27,000 x g for 15 minutes and the pellet discarded. Solid ammonium sulfate was slowly added, with stirring, to 65% saturation. After the ammonium sulfate was dissolved the precipitate was stirred for ten minutes, then centrifuged at 27,000 x g for 15 minutes. The supernatant was discarded and the pellet was taken up in a few mls of A buffer (0.01 M ammonium acetate, pH 5.0), dialyzed overnight against three hundred volumes of A buffer, and centrifuged at 27,000 x g for 15 minutes to remove precipitated material. After centrifugation the supernatant was passed sequen-

tially over an affinity column (DNA ECTEOLA-cellulose, Matsokis and Georgatsos, 1976) and then phosphocellulose (Oshima and Price, 1973). The column size (1 x 10 cm) described by Matsokis and Georgatsos is inadequate for preparative amounts of material; a larger (2 x 15 cm) column requiring more ECTEOLA-cellulose and calf thymus DNA is necessary. The phosphocellulose column was 1 x 10 cm. Both columns were equilibrated with acetate buffers (0.01 M and 0.2 M respectively). The DNA ECTEOLA-cellulose column was washed with 0.01 M acetate until the absorbance at 280 nm was zero. DNase-1 was then eluted with 0.01 M acetate, which was 0.06 M NaCl (Figure 4.1) The phosphocellulose column was washed with 0.9 M acetate buffer until the absorbance at 280 nm was zero. DNase-1 was then eluted with a linear gradient from 0.9 M acetate buffer to 0.5 M acetate buffer with 0.2 M Na_2SO_4 (Oshima and Price, 1973). In test tube assays, acid DNase activity was almost totally inhibited by 0.1 M Na_2SO_4 and 50% inhibited by 0.5 M Na_2SO_4 (Detwiler, unpublished observation). A last step which was required was chromatography of the sample over G-75 Sephadex to remove low molecular weight contaminants (Figure 4.2). For Sephadex chromatography 1 ml samples of extract from the ammonium sulfate step were dialyzed against 0.05 M phosphate buffer, pH 6.8., at 0°C and applied to a 1 x 40 cm column of Sephadex G-75 equilibrated with the same buffer. Flow rate was 6 ml/hr; 1.5 ml fractions were collected.

The degree of purification achieved at each step is given in Table 4.1. The degree of purification was not determined for elution

Figure 4.1 Elution profile of acid DNase activity from DNA
ECTEOLA-cellulose. Protein was determined by absorbance of fractions at 280 nm. DNase activity was eluted with 0.06 M NaCl at position indicated by the arrow.

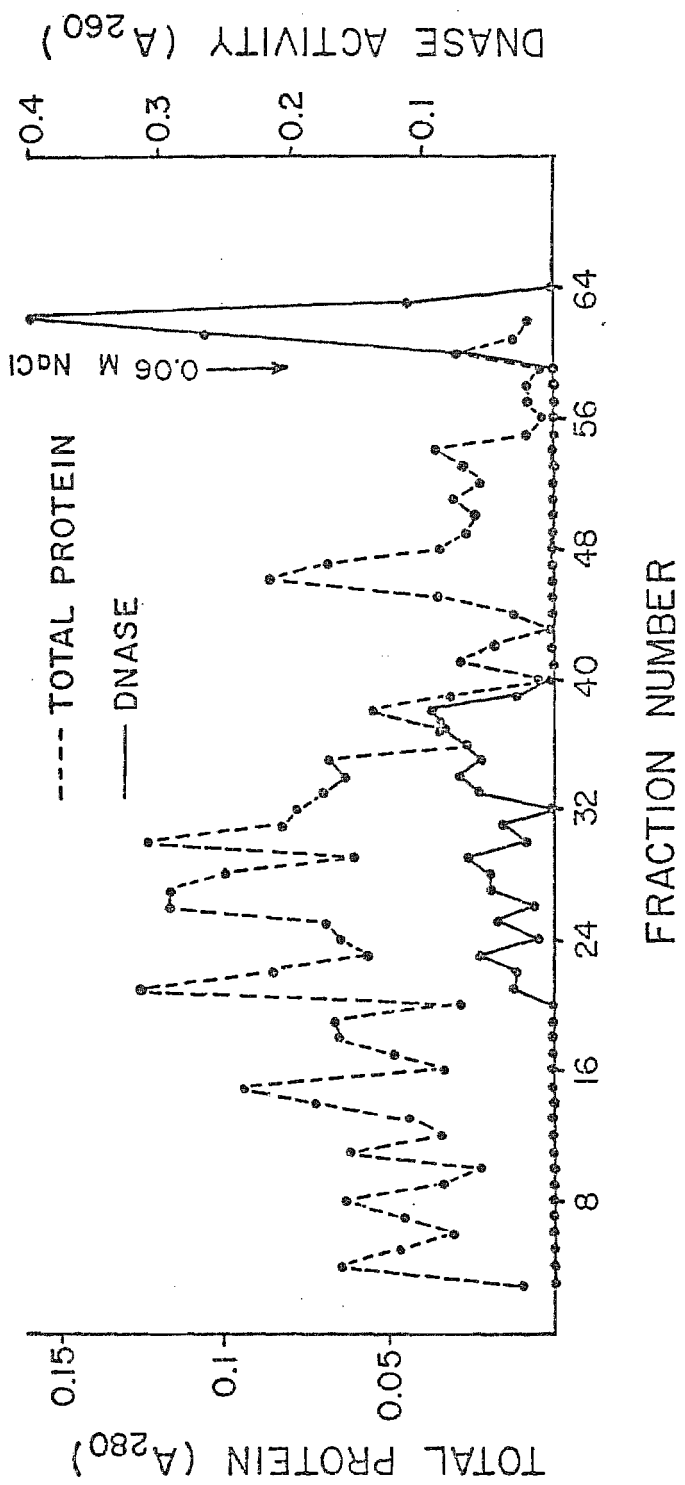

Figure 4.2 Elution profile of acid DNase activity from Sephadex G-75. Protein was determined by the Lowry et al. (1951) method.

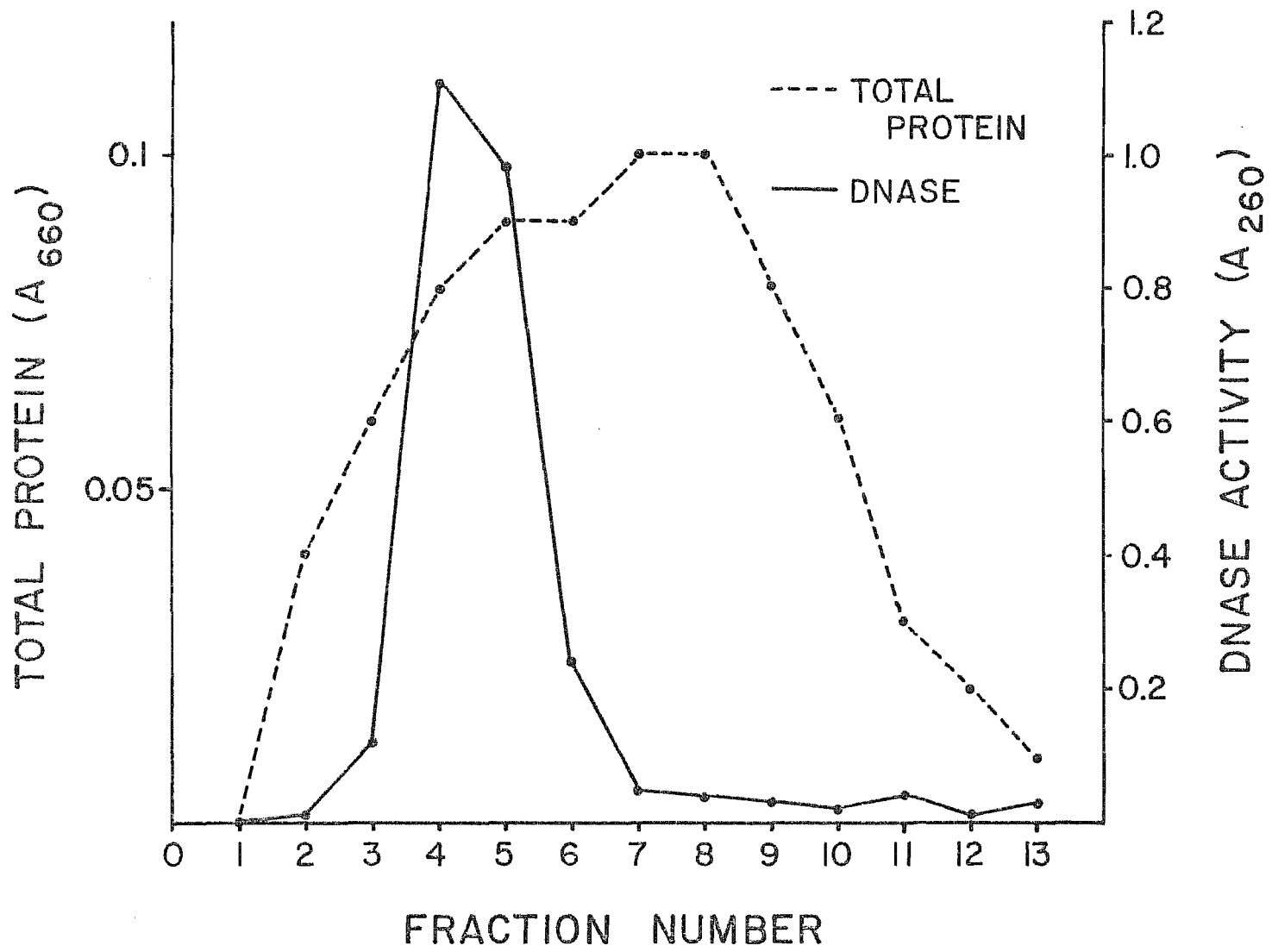

Table 4.1 Partial purification of acid DNase from D. melanogaster.

<u>Purification Step</u>	<u>Total Volume (ml)</u>	<u>Total Units*</u>	<u>Yield (%)</u>	<u>Total Protein (mg)</u>	<u>Specific Activity</u>	<u>Purification</u>
Crude extract	35.5	653.2	100	35.50	18.4	0
Acid precipitation	36.0	(64.8)**	---	20.80	-----	----
Salt precipitation	4.2	564.5	86	1.09	258.9	14.1
DNA affinity	12.0	338.9	52	0.27	1254.8	68.2

* 1 unit = the amount of enzyme liberating PCA soluble oligonucleotides sufficient to give a corrected value of $A_{260} = 1.00$ at 37°C after 20 minutes.

**activity after dialysis in H buffer was 1/10 that of the crude extract; activity is regained during the salt precipitation step.

of the extract from phosphocellulose. Figure 4.1 shows the elution profile of DNase activity from the DNA affinity column. Figure 4.2 shows a Sephadex G-75 elution profile of DNase activity from an extract that was purified as far as the salt precipitation step. Peak activity fractions from the Sephadex column and from the DNA affinity column were subjected to electrophoresis in SDS-acrylamide gels as described by Laemmli (1970). Samples from the DNA affinity column exhibit 4-5 major bands in a region of the SDS gel corresponding to molecular weights of between 30,000 and 50,000. Two of these bands (indicated by arrows in Figure 4.3) have molecular weights of 38,000-40,000, determined by comparisons in gels with samples of bovine serum albumin, catalase, ovalbumin, trypsin, hemoglobin, lysozyme and cytochrome c. The bands are close together and darker than all other bands in the vicinity. The molecular weights of these proteins are quite similar to the molecular weights of a variety of acid DNases from calf thymus, porcine spleen (MW = 38,000) and human gastric mucosal tissue (MW = 38,000) (Kowalski and Laskowski, 1976). Also, two electrophoretically distinct forms of DNase-1 occur in the pupae used in this purification (Detwiler and MacIntyre, 1978). If these forms differ slightly in size, they could correspond to the two bands indicated in the SDS gels. It should be noted that samples from the Sephadex G-75 peak exhibit the same two bands with less contamination due to higher molecular weight substances (Detwiler, unpublished observation). The major obstacle to further purification is a class of low molecular weight contaminants, seen

Figure 4.3 SDS acrylamide gel showing position of bands corresponding to major acid DNase activity. Pockets 1, 2 are aliquots from the pooled DNA affinity peak. Pockets 3, 4 are aliquots from the ammonium sulfate precipitate. Pockets 5, 6 are synthetic molecular weight markers. (BDH Chemicals Ltd.) (M) = monomer, MW: 14,300; (D) = dimer, MW: 28,600; (T) = trimer, MW: 42,900.

on SDS gels, which are not separable from acid DNase activity by a gel filtration step. The contaminants may be proteolytic fragments or glycoproteins. Because fragments are present after gel filtration and SDS sample preparation under conditions which are inhibitory to most proteolytic activity (2 nM PMSF, 0.24 ug/ml Pepstatin; pre-heating of SDS sample buffer), it is questionable whether proteolysis is the cause of the contaminants.

BIBLIOGRAPHY

- Detwiler, C. R. and R. J. MacIntyre (1978). A genetic and developmental analysis of an acid deoxyribonuclease in Drosophila melanogaster. Biochem. Genet. 16, 1113-1138.
- Kowalski, D. and M. Laskowski (1976). Functional Characteristics of Nucleophosphodiesterases. In: Handbook of Biochemistry and Molecular Biology, Ed. by G. D. Fasman. CRC Press, Cleveland.
- Laemmli, U. K. (1970). Cleavage of structural proteins during assembly of the head of bacteriophage T₄. Nature 227, 680-685.
- Lowry, O. H., Rosebrough, N. J., Farr, A. L., and R. J. Randall (1951). Protein measurement with the folin phenol reagent. J. Biol. Chem. 193, 265.
- Matsokis, N. and J. G. Georgatsos (1976). A rapid method for the purification of acid deoxyribonucleases. Anal. Biochem. 71, 290-293.
- Oshima, R. G. and P. A. Price (1973). Alkylation of an essential histidine residue in porcine spleen deoxyribonuclease. J. Biol. Chem. 248, 7522-7526.

A GENETIC AND DEVELOPMENTAL ANALYSIS OF DNASE-1, AN ACID DEOXYRIBO-
NUCLEASE OF DROSOPHILA MELANOGASTER.

Charles Roger Detwiler, Ph.D.
Cornell University 1979

A study was undertaken to characterize an acid deoxyribonuclease in Drosophila melanogaster called DNase-1, which is maximally active at pH 4.8 in the presence of EDTA. The structural gene for the enzyme was located genetically between bx and sr at 61.8 on the third chromosome. Cytogenetically, the DNase-1 locus was located within a 5-10 band interval between 90C2 and 90E on the salivary gland chromosome map. The cytogenetic localization utilized crosses between electrophoretic variants and a series of Y-autosome translocations. These translocation strains were also used to define a region on the left arm of the third chromosome (67C-70C) for which duplications resulted in an increase in DNase-1 activity. The increase was not allele-specific. A screen was designed utilizing a deficiency containing the DNase-1 locus to recover null activity mutants. From 1143 EMS mutagenized chromosomes, eight null activity variants were recovered. Four of the null mutants in homozygous condition are completely viable and fertile.

The subcellular location of the DNase-1 gene product in embryonic tissue, using a wild type strain and the homozygous null activity strain DNase-1ⁿ³²⁴, was determined. The majority of total acid DNase and DNase-1 activity is found in the small particulate fraction of tissue homogenates fractionated by differential centri-

fugation. The activity exhibits latency in these extracts indicating that it is membrane delimited. DNase-1 activity also coequilibrates in sucrose density gradients with acid phosphatase activity which, in Drosophila, is known to be lysosomal. These results suggest that DNase-1 is localized largely within the lysosomes of embryonic tissue. Functional implications of a lysosomal location for DNase-1 are discussed.

The developmental profile of DNase-1 activity has been analyzed in DNA-acrylamide gels. DNase-1 is present in all stages of the life cycle, and in embryos exhibits the maternal effect observed in several other Drosophila gene-enzyme systems. Its activity is most prominent during the pupal stage suggesting its involvement in tissue histolysis during pupation. Using staged embryos from a cross between homozygous null mutant females and wild type males, it was determined that the embryonic genome begins functioning between 0 and 1 hour after fertilization. Developmental and fecundity studies using a strain homozygous for the null activity allele DNase-1ⁿ³²⁴, suggest that null activity mutations have no significant effect on the length of the life cycle or on the rate of egg production.

DNase-1 has been partially purified from extracts of pupae. The purification consists of an acid precipitation followed by precipitation with ammonium sulfate. The resultant crude extract is passed over a DNA ECTEOLA-cellulose affinity column. A 70 fold purification has been achieved with a 52% yield.