

From Radio to In-Pipe Acoustic Communication for Smart Water Networks in Urban Environments:
Design Challenges and Future Trends

Original

From Radio to In-Pipe Acoustic Communication for Smart Water Networks in Urban Environments: Design Challenges and Future Trends / Fishta, Markeljan; Raviola, Erica; Fiori, Franco. - In: INFORMATION. - ISSN 2078-2489. - ELETTRONICO. - 14:10(2023). [10.3390/info14100544]

Availability:

This version is available at: 11583/2982777 since: 2023-10-05T13:35:45Z

Publisher:

MDPI

Published

DOI:10.3390/info14100544

Terms of use:

This article is made available under terms and conditions as specified in the corresponding bibliographic description in the repository

Publisher copyright

(Article begins on next page)

Review

From Radio to In-Pipe Acoustic Communication for Smart Water Networks in Urban Environments: Design Challenges and Future Trends

Markeljan Fishta , Erica Raviola  and Franco Fiori * 

Department of Electronics and Telecommunication, Politecnico di Torino, 10129 Turin, Italy; markeljan.fishta@polito.it (M.F.); erica.raviola@polito.it (E.R.)

* Correspondence: franco.fiori@polito.it; Tel.: +39-0110904141

Abstract: The smart management of water resources is an increasingly important topic in today's society. In this context, the paradigm of Smart Water Grids (SWGs) aims at a constant monitoring through a network of smart nodes deployed over the water distribution infrastructure. This facilitates a continuous assessment of water quality and the state of health of the pipeline infrastructure, enabling early detection of leaks and water contamination. Acoustic-wave-based technology has arisen as a viable communication technique among the nodes of the network. Such technology can be suitable for replacing traditional wireless networks in SWGs, as the acoustic channel is intrinsically embedded in the water supply network. However, the fluid-filled pipe is one of the most challenging media for data communication. Existing works proposing in-pipe acoustic communication systems are promising, but a comparison between the different implementations and their performance has not yet been reported. This paper reviews existing works dealing with acoustic-based communication networks in real large-scale urban water supply networks. For this purpose, an overview of the characteristics, trends and design challenges of existing works is provided in the present work as a guideline for future research.

Keywords: acoustic wave communication; channel characterization; data transmission; underwater communication; urban water supply system; guided wave propagation



Citation: Fishta, M.; Raviola, E.; Fiori, F. From Radio to In-Pipe Acoustic Communication for Smart Water Networks in Urban Environments: Design Challenges and Future Trends. *Information* **2023**, *14*, 544. <https://doi.org/10.3390/info14100544>

Academic Editor: Zahir M. Hussain

Received: 21 August 2023

Revised: 28 September 2023

Accepted: 29 September 2023

Published: 4 October 2023



Copyright: © 2023 by the authors. Licensee MDPI, Basel, Switzerland. This article is an open access article distributed under the terms and conditions of the Creative Commons Attribution (CC BY) license (<https://creativecommons.org/licenses/by/4.0/>).

1. Introduction

In recent years, Smart Water Grids (SWGs) have arisen as a solution to the management of water resources through constant monitoring [1–5]. SWGs leverage Internet of Things (IoT) technologies to establish a network of smart nodes deployed throughout an Urban Water Supply Network (UWSN), enabling continuous monitoring and data acquisition regarding the network's state. The measured data are then typically gathered on a cloud server, where signal elaboration and visualization are performed. Measured information includes, but is not limited to, pressure, temperature, flow, pH and turbidity. Such parameters can be used to assess water quality [6,7], detect and locate leaks [3,8] and monitor the state of health of the structure in general [9,10]. Data transfer among the nodes of the Wireless Sensor Network (WSN) relies on radio-based communication in the vast majority of cases. However, other types of physical signals, such as optical and acoustic waves, are increasingly used in all those instances where traditional wired or wireless infrastructure is unavailable or ineffective. In those cases, the information can be conveyed through the water distribution pipeline instead of the radio channel.

The underwater communication channel has proven to be very challenging for the development of communication systems based on optical and acoustic technologies. For instance, data exchange based on optical signals in underwater environments is vulnerable to absorption, scattering and dispersion, besides being affected by water turbidity [11]. Nevertheless, technology based on acoustic waves has emerged as a useful solution for

underwater communication due to its lower absorption, which allows for long communication ranges.

In recent years, the number of works investigating acoustic communication technology in fluid-filled pipelines has constantly increased [12–21], in the areas of industrial communication [22,23], drilling applications [24,25] and offshore oil and gas extraction [11,26,27]. The common denominator of these different contexts is the existence of a fluid-filled pipeline, which can act as a guide for the acoustic signals that carry the information. Existing research has highlighted several challenges in the use of acoustic waves to transmit data in water pipelines, but the provided information is fragmented. Indeed, none of the previous surveys regarding SWGs addressed the case of an in-pipe acoustic communication network.

The present work provides a survey of research papers investigating data transmission in water pipes through acoustic waves, in real large-scale UWSNs. Possible applications and communication channel parameters have been identified with reference to standard radio-based SWGs. The goal of the present work is to underline the main challenges faced by SWGs based on in-pipe acoustic communication and to suggest possible research directions.

The remainder of the paper is organized as follows: In Section 2, a brief review of SWGs based on traditional WSNs is reported to provide the reader with some background on the topic. Then, in Section 3, the SWG architecture based on in-pipe acoustic communication among nodes is introduced. Existing works dealing with acoustic communication in water pipes are briefly reviewed with a strong emphasis on those targeting real, large-scale UWSNs. A detailed comparison of different aspects of these works is provided in Section 4, focusing on channel characterization, noise characterization and communication layer design. Conclusions are drawn in Section 5.

2. Review of SWGs Based on Standard Radio Communication

As it was pointed out in the introduction to this review, several works proposed the integration of IoT in water supply networks with the purposes of improving water management, of detecting and localizing leaks and of assessing water quality thoroughly.

The outlook presented in what follows aims to provide the reader with an overview of the state-of-the-art systems based on traditional wireless communication networks, such as GPRS and WiFi, for the monitoring of water supply networks. It is intended to provide some details regarding the possible applications, the sensors exploited and the characteristics of the wireless communication channel. More exhaustive reviews on SWGs can be found in the literature [2,4,6,28–31].

A typical case scenario is that shown in Figure 1, which depicts the architecture of an SWG for UWSNs. The hydraulic network comprises the pipelines themselves, reservoirs, air valves, pumping stations, hydrant attacks, etc. The topology of such hydraulic networks is rather complex, with bifurcations, loops and dead pipes, and it is characterized by a significant geographical extension of tens of squared kilometers in urban contexts. The monitoring nodes are typically placed at key points of the water supply network, e.g., close to reservoirs, or exploit existing access points, such as fire hydrants. Therefore, in most of the applications, the monitoring nodes are fixed in pre-determined positions. Besides this solution, mobile nodes have been also designed, such as those in [32], in which the monitoring units flow into the pipe and can anchor themselves in a predetermined location by means of mechanical arms.

Regarding the scenarios depicted in Figure 1, each of the monitoring nodes can be either provided with internet connection (see Figure 1 on the right), e.g., using an on-board GPRS modem, or not (see Figure 1 on the left). The former does not require practitioners to set up a local wireless network, and it is mostly suitable for the monitoring of urban areas with a large geographical extension. On the contrary, the latter requires the use of a gateway as an interface between the local area network and the internet, and it may be more convenient than the former case in terms of costs for small networks. The cloud server typically comprises a back-end, which includes a database to store the collected data

and a computational module to extrapolate further information, and a front-end, which is mainly responsible for visualizing data to UWSN operators.

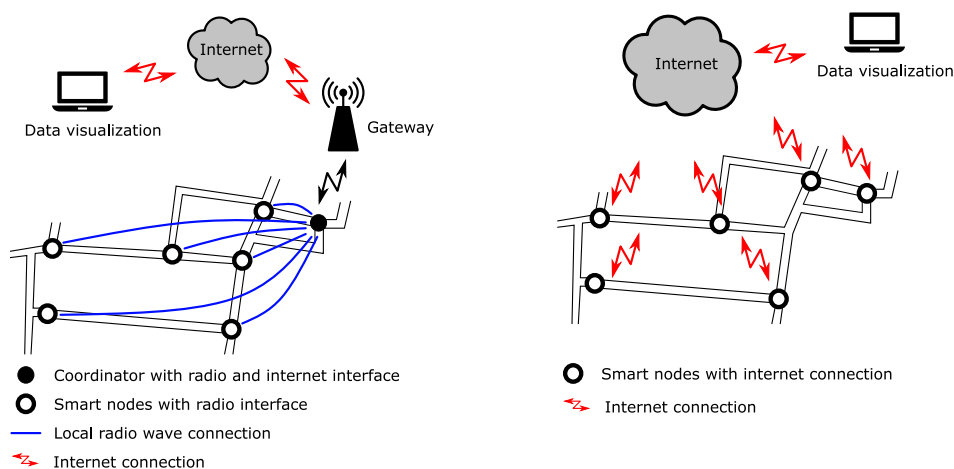

Figure 1. Radio-based architectures.

Depending on the target application, previous works can be classified as designed for water quality, for monitoring the hydraulic network itself, e.g., leak detection and localization, or for both water quality and hydraulic assessment. In Table 1, the main characteristics of existing SWGs are reported, including which sensors have been exploited, the radio protocol and the deployed location.

Table 1. Existing smart water grids.

Ref.	Deployed Location	Aim	Water Quality Sensors	Hydraulic Sensors	Wireless Protocol	Nro. Nodes	Extension or Distance
[33]	Singapore	Leak detection, water quality monitoring, online hydraulic calibration, model-based prediction	pH, conductivity, temperature, ORP	pressure, hydrophone, flow	3G	10 s	80 km ²
[34]	laboratory	Domestic water consumption monitoring	none	flow	Zigbee	1	8.5 km
[35]	IIT Madras campus, Chennai, India	Remote water level monitoring and valve attuation	none	water level	LoRa and GSM	5	1.6 km
[36]	Portion of UWSN in Shenzen, China	Water demand estimation without flow sensors	none	pressure	Zigbee	24	130 m
[37]	Civil Eng. dept., Strovolos, Cyprus	Multi-parameter decision system for leak detection and localization	none	pressure, hydrophone, flow	433 MHz motes	4	70 m
[38]	laboratory	Real-time water quality monitoring	pH, conductivity, temperature, ORP	flow	Xbee	1	20 m
[39]	laboratory	Domestic water consumption monitoring and leak alert	none	flow	WiFi	1	n/a
[40]	laboratory	Online water quality monitoring	pH, turbidity, conductivity, ORP temperature	flow	Zigbee	1	n/a
[41]	160k-people city in UK	Hydraulic model to optimize UWSN management	none	pressure, flow	GPRS	n/a	n/a
[42]	ten municipalities near Cordova, Spain	Detection and classification of incidents in water supply network	none	pressure	Sigfox	8	600 km ²
[43]	Adelaide city center, Australia	Leaks detection and localization	none	hydrophone	3G	305	6.2 km ²
[44]	India Institute of Science campus, Bangalore, India	Water distribution management, water level in tanks	none	water level	sub-1 GHz radio	10	1 km

2.1. Water Quality Assessment

Water quality assessment deals with the monitoring of physical, chemical and biological parameters of the supplied water and their compliance with the limits imposed by

national regulations. Amongst the several parameters that are required to be monitored, turbidity is a measure of suspended organic and nonorganic matter. A high turbidity level causes water to seem dirty, damages fixtures and may prevent water treatments from being effective. A pH level lower than 6.5 is an indicator of possible lead or iron contamination from the aquifer, the plumbing fixtures and the pipes, resulting in soft corrosive water. In the case of conductivity, this parameter measures the concentration of ions. High conductivity can be caused by natural sources, e.g., minerals and rocks, or by anthropogenic ones, including industrial activity and run-off from roads. The Oxidation Reduction Potential (ORP) can be exploited to classify substances as oxidizing or reducing agents, depending on whether the substance is lacking or has extra electrons.

Water quality may be affected due to poor water treatments or the presence of unwanted contaminants, leading to health issues for the final consumers, bad water taste and a corrosion of the pipelines. For all these reasons, periodic monitoring is scheduled by water supply companies in accordance with government regulations. It consists of collecting water samples and having them analyzed by a certified laboratory. On the contrary, continuous water quality monitoring, which would assess the presence of contaminants in advance, is typically not performed. Therefore, several attempts have been reported for distributed and continuous water quality monitoring through wireless connected sensors. In [38], an online water quality system is proposed, in which water flow, pH, conductivity, temperature and ORP are monitored and data are transmitted by means of an XBee module, allowing for a 20 m distance communication with the base station. The monitoring unit is equipped with a buzzer, which is activated when the measured parameters indicate poor water quality. Similarly, the monitoring unit proposed in [45] exploited a Wi-Fi module to transmit the data collected, and it was also provided with a motion sensor to detect possible hacking. The experiments were carried out in a laboratory. A real-time water quality system for smart cities was also designed in [46], where data from pH, turbidity, dissolved oxygen and temperature sensors were collected and transmitted over a 1.5 km Lo-Ra link. Thorough literature and market research were carried out in [40] to identify which low-cost sensors can be used to monitor the water quality reliably. Based on the selected sensors, an array was developed along with several micro-systems for analog signal conditioning, processing, logging and remote visualization of collected data. The output of each on-board sensor was sampled every 5 s, and later transmitted over a Zigbee link. The same wireless protocol was also exploited in [47], where two nodes were deployed to assess water quality along pipes. Each node was equipped with pH, turbidity, conductivity, temperature and ORP sensors. A contamination detection algorithm based on fuzzy logic was implemented on the node itself, allowing the node to shut off a solenoid valve to block the water flow through the pipeline whenever a contamination is detected. The integration of an existing remote controlling system with IoT technology was proposed in [48], in which temperature, flow and color sensors are connected to an Arduino node, which is interfaced with the server through a GPRS module. The authors also designed a mobile platform to facilitate the operators not in the control room to access the collected data.

2.2. Monitoring and Optimization of Pipeline Network

Besides water quality assessment, a continuous monitoring of the state of health of pipeline networks is beneficial as well, as it can detect early failures, i.e., leaks, or help in optimizing the water distribution across several reservoirs. Although the architecture of proposed systems is rather similar to that of systems for water quality, the exploited sensors and algorithms are different. Pressure, water level in tanks, water flow and the in-pipe acoustic noise can indeed be exploited to optimize pipeline network management.

Small-case spin-off is the method of smart water metering for domestic applications. Related works were found to be effective in estimating the current and accumulated water consumption, in detecting anomalous water consumption [39] and in raising awareness among final users about water waste [34,49]. Although these works have a positive social

impact, they were deployed in domestic buildings, and missed some of the challenges of a water supply network.

Aiming to optimize the water distribution among storage reservoirs, [35] deployed five nodes to monitor water level in tanks and to open or to close valves remotely. The proposed wireless network was based on the Lo-Ra protocol, which was combined with the GSM network to increase the overall reliability. Similarly, [44] exploited the ultrasound-based sensor level to optimize the water distribution across five overhead tanks and as many ground-level reservoirs. The developed sensor levels were found to have a 1.5 % accuracy over a 10 m full range, and a sub-GHz network allows one to collect data each minute. Some nodes were provided with relaying capability, resulting in a reliable data transfer even when a direct connection with the gateway results in a low Received Signal Strength Indicator (RSSI).

To avoid the use of flow meters, Demand Reverse Deduction (DRD) technology was assessed in [36] with the purpose of estimating the water demand. To serve this scope, only pressure sensors were exploited, whose output values were collected, transmitted over Zigbee and then fed to a purely hydraulic model. The experimental case study assessed the proposed model, especially when the water demand was low. Hydraulic models can also be exploited to assist a proactive management of the water supply network. However, to serve this scope, the model input data should be continuously updated to drive simulations representative of the actual conditions of the network [41].

Another possible application of SWGs is the detection and localization of pipe leaks, with several investigations carried out on this topic in recent decades. A multi-parameter decision system based on artificial neural networks and fuzzy logic was proposed in [37] to detect and localize leaks. More precisely, the risk of failure for each segment of the pipe network can be estimated based on historical data using a neuro-fuzzy system. Data regarding pressure, the in-pipe acoustic noise and flow rate are collected by purposely designed nodes, which are provided with 433 MHz radio transceivers.

The WAIter tool was instead proposed in [42], and is based on IoT devices collecting pressure measurements every 11 min. Such data are sent via Sigfox to a cloud server, in which they are stored in a database. There, a failure detection algorithm is implemented using a decision tree and it is able to discern between a sensor failure, supply cut off, leaks downstream from the sensor and leaks upstream from the sensor. In [43], 305 acoustic loggers, built up using magnetically clipped accelerometers, were deployed to measure in-pipe noise. As a result of a 2-year-long measurement campaign in Adelaide city center, the system was able to detect leaks before break, being successful in 55 % of the cases. Classification between circumferential and longitudinal cracks was achieved on the basis of the noise signature and how it changed over time.

2.3. Hydraulic and Water Quality Monitoring

A few works have proposed a system which includes both water quality and pipeline network online monitoring. A first attempt made in this regard is the PIPENET project [50], which aims at detecting, localizing and quantifying bursts, leaks and other anomalies in water pipelines. The deployed monitoring units were divided into three clusters: the first included pressure and pH sensors, the second pressure sensors only and the third cluster comprised level meters to monitor water level in reservoirs. Preliminary deployment in a laboratory showed promising results; however, during the in-field tests in Boston, several critical issues were found. Indeed, as this was a real large-scale deployment case, harsh environment, data transfer loss and time synchronization amongst nodes were identified as critical aspects to develop further.

More recently, the WaterWise system proposed in [33] combined the assessment of water quality with leak detection using an in-pipe hydrophone. The monitoring unit was designed as a multi-probe installed on the pipe through a gate valve. It included pressure, hydrophone, flow, pH, conductivity, temperature and ORP sensors, whose data were sent every 5 min through the 3G network. Amongst the decision support scenarios

WaterWise can cope with, the authors emphasized the detection and resolve of a leak and the optimization of pump scheduling.

2.4. Wireless Communication Parameters

Based on the works previously reviewed, some common indicators were collected. The aim is to highlight the characteristics of a wireless link suitable for SWGs at the system level, independently of the adopted protocol. They include the maximum distance between two wireless-connected nodes, which can either be that between two monitoring nodes or a node and the gateway, depending on which is higher, and how often data are transmitted over the wireless channel. The former, i.e., the distance, is reported in Figure 2, in which circle markers refer to works in which the experimental validation was carried out in a laboratory, and diamond ones to those deployed in a real case pipeline. What stands out in Figure 2 is that in practical water supply networks, the distance between two nodes ranged from about 70 m up to 2 km. The report time plotted in Figure 3 measures the time between two consecutive data transmissions over the wireless channel. This parameter has an impact on the lifetime of battery-powered wireless sensor nodes since the wireless transmission is the most energy-consuming operation [51]. It is worth noting that in laboratory-assessed works (circle markers), the report time is no longer than 1 min, while it can span up to 20 h in a real pipeline scenario (diamond markers).

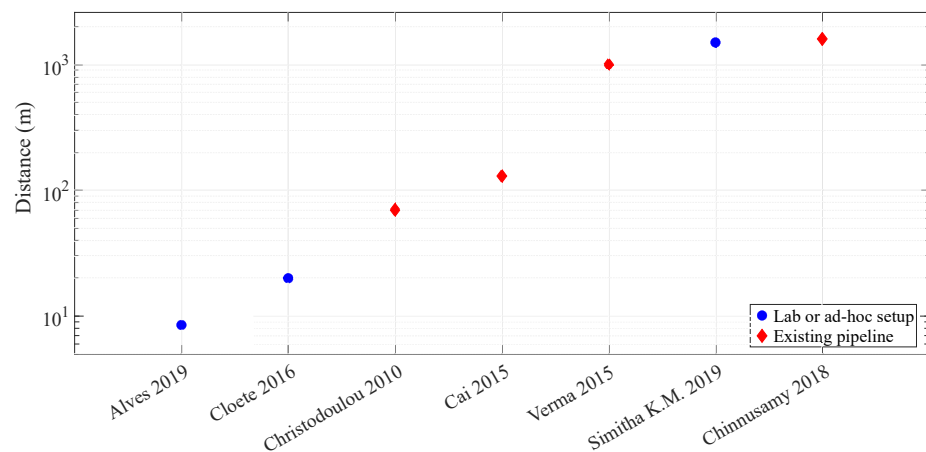

Figure 2. Maximum distance between two wireless-connected nodes in SWNs reviewed so far. The case of GPRS/3G connection is not considered.

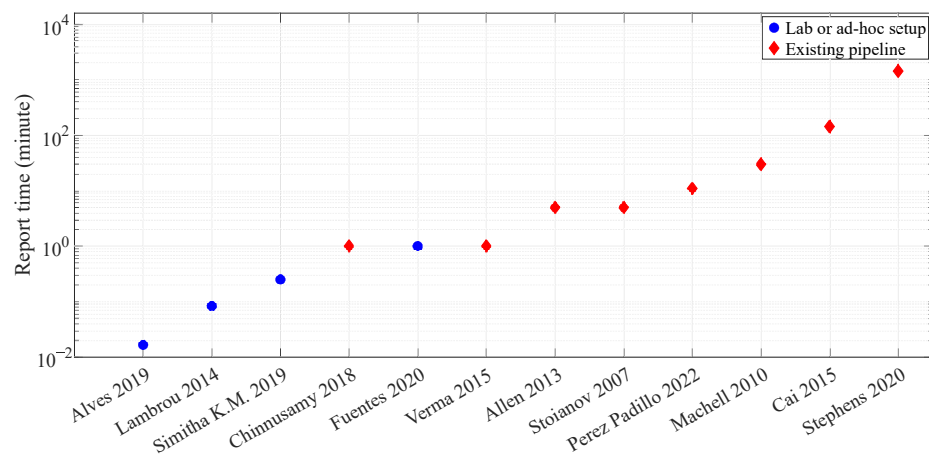

Figure 3. Time between two data transmissions from a remote monitoring unit to the central one/gateway.

3. Acoustic-Based Communication

As presented in the previous Sect., SWGs deal with the management of water distribution networks [1]. As far as the communication network of such SWGs is concerned, it results from previous reviews [2–5] that the vast majority of the cases employ radio wave communication for information transfer between the sensor nodes of a network. However, the review in [1], among the various wireless techniques, also considered acoustic-wave-based communication as a possible way to transfer information, since it is effectively a wireless communication technique.

The reason for preferring underwater communication to terrestrial is related to the fact that in urban scenarios the sensor nodes are placed underground, close to the water pipeline. In such scenarios, the radio technology suffers from radio penetration issues [1], which requires that a portion of the sensor node be placed near the ground, making the node less compact. Acoustic waves, instead, lend themselves well since they travel over fluid-filled pipes, conveying information among various sensor nodes. Moreover, the GSM network might be unavailable in remote areas, making communication directly through the pipe the best option. Lastly, even where GSM connectivity is available, some misoperations of the GSM network might occur, leading to a temporary unsupervised operation of the UWSN. On the contrary, an acoustic-based communication network relies on a physical channel that is not affected by service outage intrinsically, as the water flow must always be guaranteed.

Acoustic-wave-based communication allows for a long propagation distance in underwater environments, as compared to other techniques, due to the low sound absorption underwater. In order to cover long propagation distances, the transmission frequency must be low; hence, acoustical communications are limited to bandwidths that are lower with respect to those used for terrestrial radio communications. Although [1], among others, states that distances of the order of km can be reached with acoustical communication, this is mainly true for the open-sea underwater case, where acoustic transducers can have a large size and high power consumption. In urban areas instead, mounting spaces are limited by the size of manholes; hence, acoustic transducers cannot be so large. Also, the power consumption must be reduced, aiming to move towards a system where the sensor nodes are supplied by batteries or by recovering energy from the environment. Moreover, it is anticipated that sound attenuation for the guided wave propagation is much larger than the one in the free-space case. The combination of these factors limits communication distances to a few tens of meters.

Based on what has been presented so far, a schematic description of an SWG with acoustic-wave-based communication can be seen in Figure 4.

It is important to note that the acoustic communication channel is intrinsically meshed, which makes it more robust since multiple paths exist between two sensor nodes. As shown, the same concept as in traditional SWGs shown in Figure 1 on the left can be applied, where only the local connections between sensor nodes are replaced by acoustical communication. A few nodes with internet access, named coordinators, are needed to convey the gathered information to the common server, where the data processing takes place. It must be stressed that even though the communication medium has changed, the remainder of the SWG, including the sensed quantities and signal processing algorithms discussed in Section 2, can remain the same.

In order to enable data transfer through the pipeline network itself, a communication system has to be set up. The propagation medium is the water–pipe–soil ensemble, and most of the energy should propagate inside the fluid to yield a longer reach [13]. The traditional sensor nodes have to be altered so they can generate and sense acoustic waves. This is achieved by equipping them with electro-acoustical transducers, the needed electronic interface circuitry and a proper communication layer implemented on the controller. Conversely to the use of radio-wave-based communication, where standard solutions are readily available as commercial modules, nodes with acoustic transmission and reception

capabilities must be custom-built, since the specifications in terms of pipeline geometries, available mounting space and maximum power consumption are heavily case-dependent.

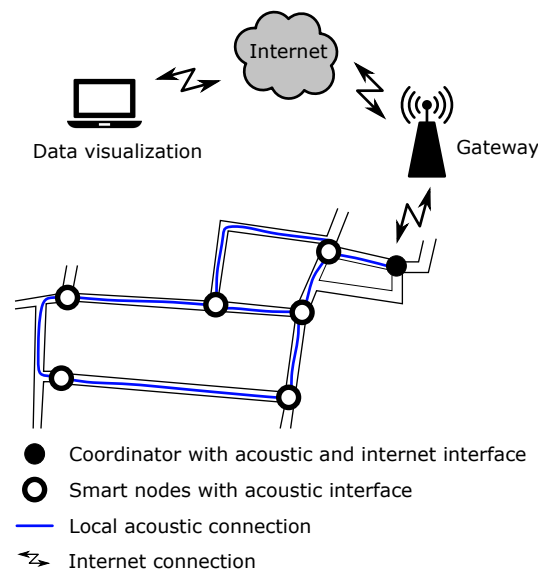

Figure 4. Schematic representation of an SWG with communication based on the propagation of acoustic waves.

3.1. Existing Works Based on Guided Acoustic Communication

Works dealing with underwater WSNs based on acoustic communication are mainly concerned with the open-sea case [52–54], while the number of works meant for urban applications is much more limited. However, in recent years, this topic has acquired more and more importance. Although SWGs employing acoustical communication have not yet been reported, several works have started to lay the foundations for such a wireless network. Among these, ref. [14] was one of the first to investigate data transmission through acoustic waves in water pipelines. Its study provided many useful insights into the dispersive nature of the channel and highlighted its low-pass frequency response. The work was mainly theoretical and it investigated the effect of various physical parameters of the system on sound propagation. After that, various research works presented point-to-point communication systems, confirming the feasibility of data transmission. Chakraborty et al. [23] reported a system for data transmission along a cylindrical pipe using ultrasonic waves. The system employed a chirp On–Off Keying (OOK) modulation scheme with a carrier frequency of 455 kHz. Experimental tests were conducted over a 4.8 m length of pipe, first in an air-filled setup and subsequently in a water-filled configuration. Jing et al. [12] presented the characterization of pipelines as acoustic waveguides for data transmission. The characterization was performed over a frequency band of 1–50 kHz by using a mode-based model. However, experimental measurements on a 5.8 m long water-filled pipe did not show a good agreement with the analytical model. The design of a stress wave communication system for underwater applications was reported in [11]. In such a case, the channel was characterized in the frequency band from 20 kHz to 60 kHz and PSK modulation was employed with a 40 kHz carrier frequency. Experimental tests were carried out on a 3 m long steel pipe both in air and in water. Farai et al. [18] presented a low-frequency acoustic system for digital communication along exposed and buried pipes. The employed frequencies were sub-kHz and the work showed that analytical models do not accurately predict the acoustic signal attenuation. Measurement results on a test rig were used to estimate the maximum communication range. The test setup made use of a 40 m long polyethylene pipe and it included a vibration motor to generate the sound waves on the pipe wall and accelerometers to sense said waves. Experimentally measured acoustic attenuation over a distance of 6 m yielded estimations of a maximum distance of 18 m and 5 m for exposed and buried pipes, respectively. The works presented so far have in common

the fact that experimental validation was performed in ad hoc built test rigs, with communication distance below 10 m. This is in contrast with the nature of real, large-scale water distribution networks, where the distance between adjacent access points can be several 10s of m. The only reported works dealing with acoustic communication in real, large-scale urban water distribution networks are those of Joseph et al. [13] and Fishta et al. [21]. These works will be presented briefly at first and then, in the following section, a comparative study of the communication system implementations will be provided.

3.2. Joseph et al. [13]

This work was the first to report the use of a large-scale water distribution network for data transmission through acoustical waves. An buried iron pipe with a length of 110 m was considered as the data transmission channel. The pipe was divided into two sections with the transmitter placed in the middle and the receivers placed at distances of 40 m and 70 m. The test structure is schematically shown in Figure 5.

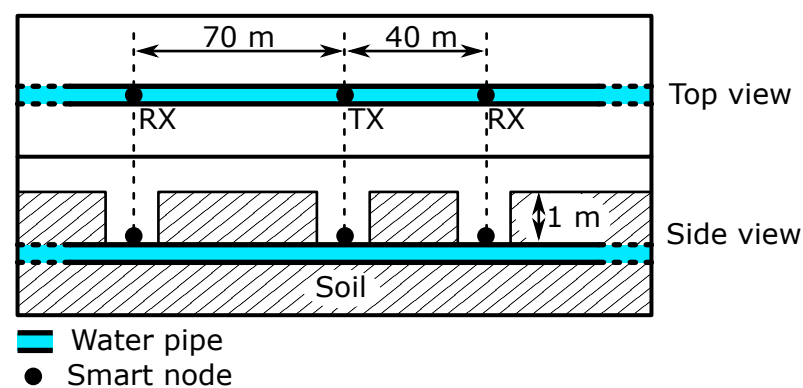

Figure 5. Schematic representation of the test structure employed in [13].

Transducers were of the piezoelectric type and they were mounted externally to the pipe wall. Such transducers were used both for signal generation and signal reception. Channel characterization was performed by applying a chirp signal with 120 s duration and by observing the spectrum of the received signal. Such spectrum was compared to that in the absence of a signal to identify a transmission band with a sufficiently high Signal-to-Noise Ratio (SNR). More precisely, a frequency band around 500 Hz was identified and chosen for the data transmission, where the SNR was about 4 dB. The nodes were custom-built and relied on the use of a microcontroller for system management. The power consumption of the node had peaks between 330 mW and 660 mW. As far as the communication layer is concerned, tests were performed with different data modulation schemes. In particular, the basic binary digital modulations were tested with a central frequency of 500 Hz. It was found that the OOK scheme was the most effective one.

3.3. Fishta et al. [21]

A method was discussed in [21] to design an acoustic-wave-based communication system, starting from the experimental characterization of the channel. The case study was a large-scale water distribution network with a ring structure providing two main propagation paths with lengths of 73 m and 165 m. The test structure is schematically shown in Figure 6.

The transducer was of the magnetic field kind while the sensors were piezoelectric. Differently from [13], the transducers were mounted so that they were in contact with the water inside the pipes. This makes the coupling of the acoustical energy to the medium much more efficient at equal electrical energy absorption. The channel response was measured using single tone-injection from 40 Hz to 200 Hz and it was found that the channel had a low-pass behavior, with frequencies above 100 Hz heavily attenuated. In addition, even for frequencies below 100 Hz, the channel exhibited severe frequency

selectivity. A local maximum of the channel transfer function was identified at 71 Hz, which was chosen as the carrier frequency for the data transmission. The nodes were custom-built and a microcontroller was used to govern the operation of the system. The communication layer relied on the use of a modified OOK modulation, allowing for a reliable communication of pressure, water temperature and self power consumption from the remote node.

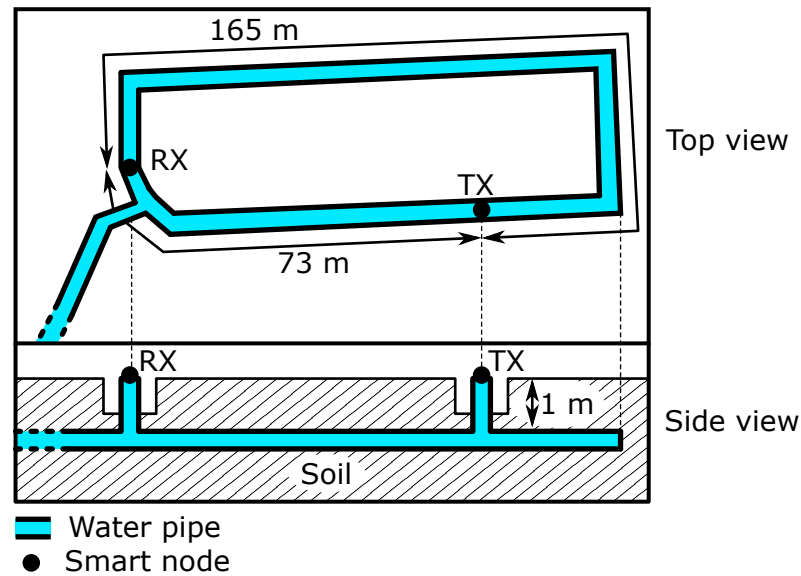

Figure 6. Schematic representation of the test structure employed in [21].

4. Characterization and Design of Acoustic Communication Systems

The previous section conducted a system-level analysis, investigating the utilization of acoustic-based communication for SWGs. To gain insight into such communication technology, this section provides more details regarding the characterization of the acoustic channel and the corresponding design methodologies. For this purpose, a generic communication system based on the guided propagation of acoustic waves is described by the block diagram in Figure 7.

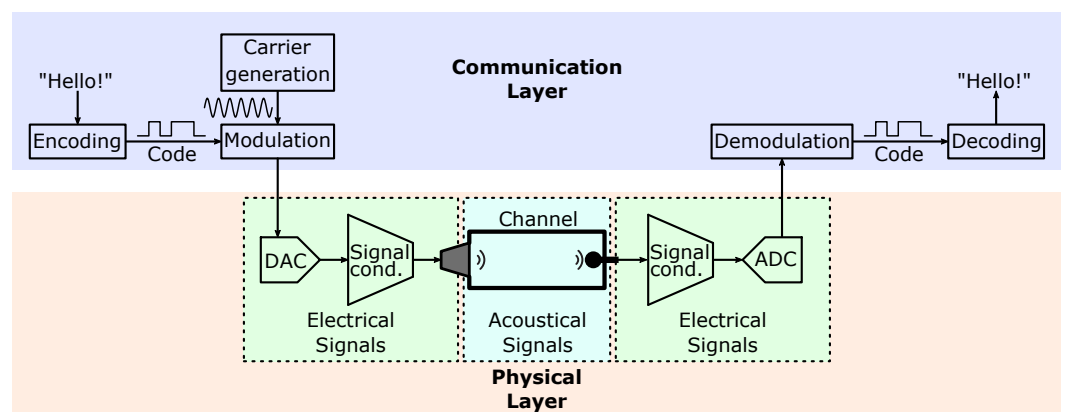

Figure 7. Block diagram description of a generic communication system based on the propagation of guided acoustic waves.

The central block is the communication channel, through which the information is propagated in the form of acoustic waves. On the transmission side, it can be seen that the message is encoded through a certain bit sequence. The encoding process can be employed to identify and potentially correct erroneous transmitted bits due to channel distortion. The encoder adds some redundant bits in the data packets that allow the receiver to identify

and correct the erroneous bits [14]. The resulting bit sequence modulates a carrier signal, resulting in an analog voltage. Such voltage is conditioned before being applied to a voltage-to-pressure transducer, which translates the voltage signal into a pressure one. The pressure signal then propagates through the channel and is sensed at the receiving side by a pressure-to-voltage transducer. The resulting voltage is a distorted version of the signal generated at the transmitter side, depending on the characteristics of the channel and the added noise. Said voltage is conditioned, before being converted to digital form, and then demodulation and decoding are performed to reconstruct the starting message. The design of the system is strongly related to the properties of the communication system, which will be treated next.

4.1. Channel Characterization

The channel characterization is required to properly design a communication system based on the exploited physical channel. This step is of the utmost importance in the case of water-filled pipes, as they show a severe frequency selectivity because of the meshed nature of the water pipeline network, which provides multiple paths for signal propagation. In the water-filled pipe, a guided propagation takes place, with the acoustic energy being guided from the pipe wall. Such acoustic propagation is usually expressed as a superposition of modes [12,14], similar to the case of electromagnetic waveguides. Assuming that a cylindrical pipe and the propagation direction are aligned with the x -axis, the cylindrical coordinate system shown in Figure 8 is adopted.

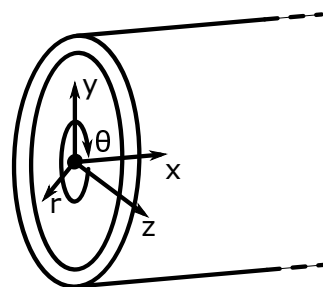

Figure 8. Cylindrical coordinate system (r, θ, x) used for the circular cross-section duct.

The polar coordinates (r, θ) are given by $y = r \cos \theta, z = r \sin \theta$ [55]. The usage of polar coordinates results in the pressure wave function being separable, meaning that it can be easily solved. The channel is characterized by determining the ratio of the received pressure signal $p_{out}(f, r, \theta, x)$ due to the application of a pressure signal $p_{in}(f, r, \theta, x)$. By using the classical expression for the acoustic pressure inside a cylindrical waveguide, the required transfer function is found as a superposition of modes using the Bessel functions [12], resulting in

$$\begin{aligned}
 H(f, r, \theta, x) &= \frac{p_{out}(f, r, \theta, x)}{p_{in}(f, r, \theta, 0)} \\
 &= \sum_{n=0}^{\infty} \sum_{m=0}^{\infty} A_{nm}(f) J_{nm}(r) \cos(n\theta) \exp(jk_{nm}(f)x) \exp(-a_{nm}(f)x),
 \end{aligned} \tag{1}$$

where the modes are indicated by the integer pair (n, m) . The function $A_{nm}(f)$ represents the amplitude of mode (n, m) , as a function of frequency; $J_{nm}(r)$ are combinations of Bessel functions; $k_{nm}(f)$ is the modal wave number; and $a_{nm}(f)$ is the exponential attenuation of the mode. A particular case that is commonly considered is that in which the pressure source is located at the center of the cross-section of the waveguide. In such a case,

the system has a circular symmetry, which corresponds to $n = 0$ and the pressure transfer function becomes

$$\begin{aligned} H(f, r, \theta, x) &= \frac{p_{\text{out}}(f, r, \theta, x)}{p_{\text{in}}(f, 0, \theta, 0)} \\ &= \sum_{m=0}^{\infty} A_{0m}(f) J_{0m}(r) \exp(jk_{0m}(f)x) \exp(-a_{0m}(f)x). \end{aligned} \quad (2)$$

The modal decomposition method is not suitable for the solution of complex acoustical problems, other than regular-shaped objects or hard-walled cavities. The reason is that when the boundary becomes irregular or elements such as branches, joints and bends are introduced, the solution of the differential equations becomes challenging, to say the least. In these cases, numerical simulation can be employed instead [56] to solve the acoustical problem. However, when dealing with real, large-scale networks, the techniques presented earlier, which rely on the physical properties of the acoustical waveguide, become impractical due to uncertainties in material properties and waveguide geometry. As an alternative, a black-box modeling approach can be considered instead. Black-box models ignore the internal structure of the system and the physical laws governing its operation and rely on information gathered from experimental measurements of the system. If the considered system is linear and time-invariant, it can be described through its impulse response in the time domain or the transfer function in the frequency domain. Black-box characterization of the channel can be performed by applying known stimuli to the channel and observing its response. Different excitations can be employed to obtain the response of the channel, such as the chirp signal [13] or single-tone excitation [57].

In [13], a linear sweep was performed from 0 to 1.2 kHz over a time interval of 120 s, to measure the frequency response of the channel. Referring to the schematic in Figure 5, the excitation signal was composed of the transmitting node placed in the middle and it was acquired by the two receiving nodes. Then, a Power Spectral Density (PSD) transform was used to obtain the frequency content of the received signal, which was compared with the PSD of ambient noise to obtain the SNR at the two receiving locations. It was found that the signal was indistinguishable from noise over the whole frequency band, except for a narrow band of 30 Hz, centered on 500 Hz, where $SNR = 4$ dB was measured. Such a value is not very high and it can result in unreliable communication. Indeed, in the case of OOK digital modulation, the theoretical Bit Error Rate (BER) can be expressed as [58]

$$BER = \frac{1}{2} \operatorname{erfc} \left(\sqrt{\frac{1}{2} 10^{\frac{SNR}{10}}} \right) = 0.113, \quad (3)$$

which is relatively large. Such computation assumes uncoded binary signals [59], considering unitary bandwidth efficiency and optimal detection [58]. It can also be noticed that the characterization procedure described in [13] does not allow one to extract the frequency response of the water-filled pipe channel. Only the received signal is analyzed while the actual excitation provided to the channel is not measured.

Conversely, [21] proposed a channel characterization procedure based on the frequency response measurement performed for electronic devices [57,60]. The proposed system architecture of the channel characterization is shown in Figure 9.

One key difference that can be noticed compared to [13] is the presence of a near-side hydrophone, which allows for the frequency response estimation of the pipe channel alone, excluding the contribution of the transducers. Another difference consisted of the mounting of the transducers, which were placed in direct contact with water. Such a solution allows for a better coupling between the transducers and the medium, but it also requires the transducers to properly operate under a large hydrostatic pressure, as well as invasive mounting. Also, the probing signal employed in [21] for characterization differs from that proposed in [13]. Instead of the chirp signal, the channel is probed with single tones, and the frequency response in magnitude and phase is extracted for each tested frequency

point. More in detail, the characterization procedure is carried out with a frequency step $\Delta f = 0.5$ Hz, between 40 Hz and 200 Hz. Voltages $v_{i,m}(t)$, with $i \in (0, 1, 2)$ the index of the acquired port and m the index of the tested frequency, are acquired and digitized into the sequences $v_{i,m}[n]$, where n is the discrete-time index. The digitized signals are processed using Discrete Fourier Transform (DFT) and the frequency-domain sample arrays

$$V_{i,m}[k] = \sum_{n=0}^{N-1} v_{i,m}[n] \cdot e^{-\frac{j2\pi}{N}kn} \tag{4}$$

are obtained, with k being the discrete-frequency index and N the number of samples. For each tested frequency, only the component that has been excited by the actuator is considered, while all the other points are discarded, yielding the complex transfer function of the channel

$$H[m] = \frac{V_{2,m}[\bar{k}]}{V_{1,m}[\bar{k}]} \in \mathbb{C} \tag{5}$$

where \bar{k} is the index of the excited frequency inside the DFT sequence. An example provided in Figure 10 for the particular case of $f = 47$ Hz shows that the received signal is much stronger than the background noise, making the characterization process very robust.

The extracted frequency response can then be employed for modeling purposes to build a simulatable model for the channel. The comparison between the measured transfer function and a vector fitting model over the frequency band 50 Hz to 120 Hz can be seen in Figure 11.

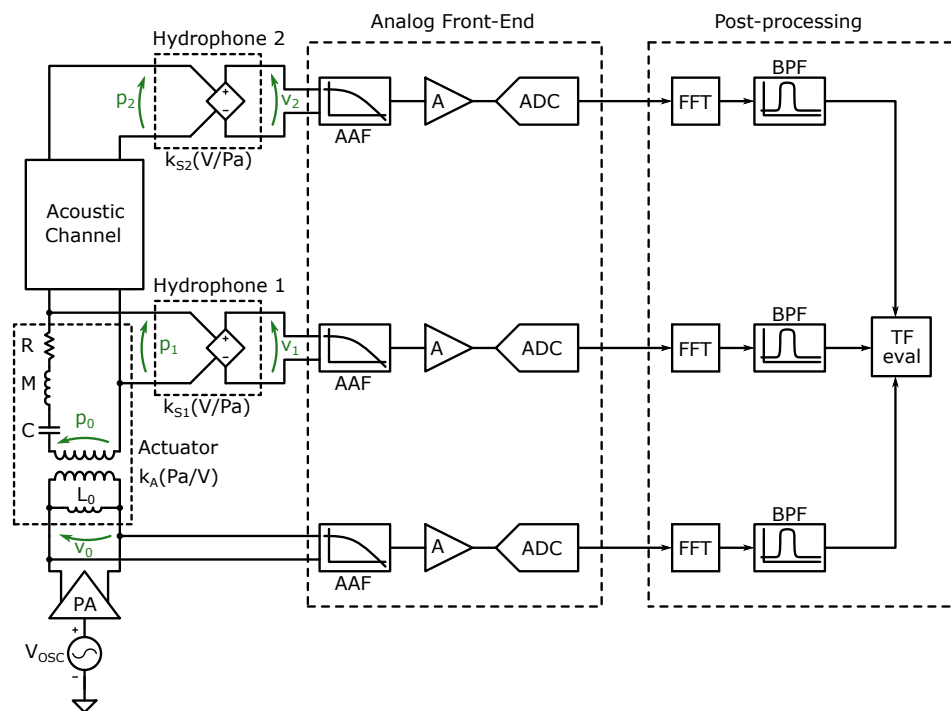

Figure 9. Block diagram of the pipe channel characterization system proposed in [57].

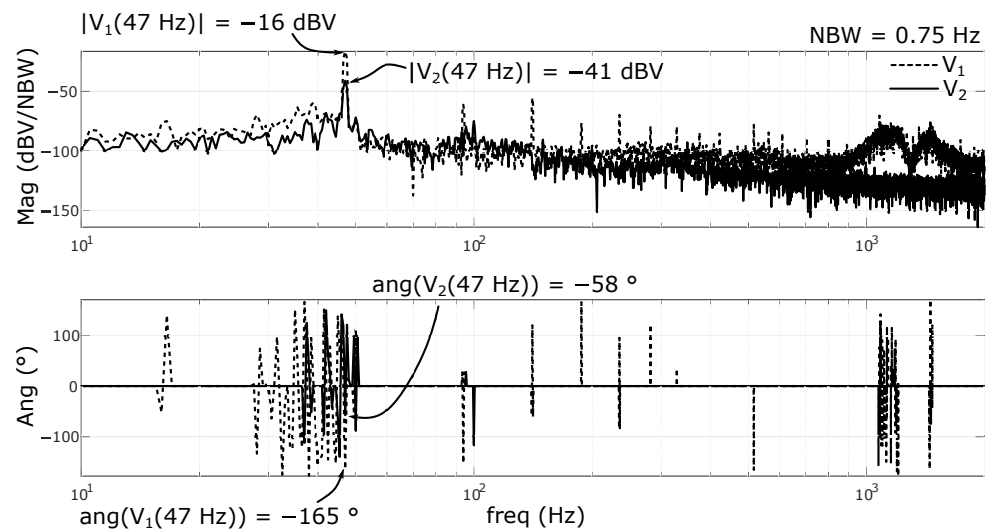

Figure 10. Example of the DFT-evaluated sequences at the near and far ends from [21], for the case $f = 47 \text{ Hz}$. The channel transfer function is evaluated by taking the magnitude and phase difference at the excited frequency point.

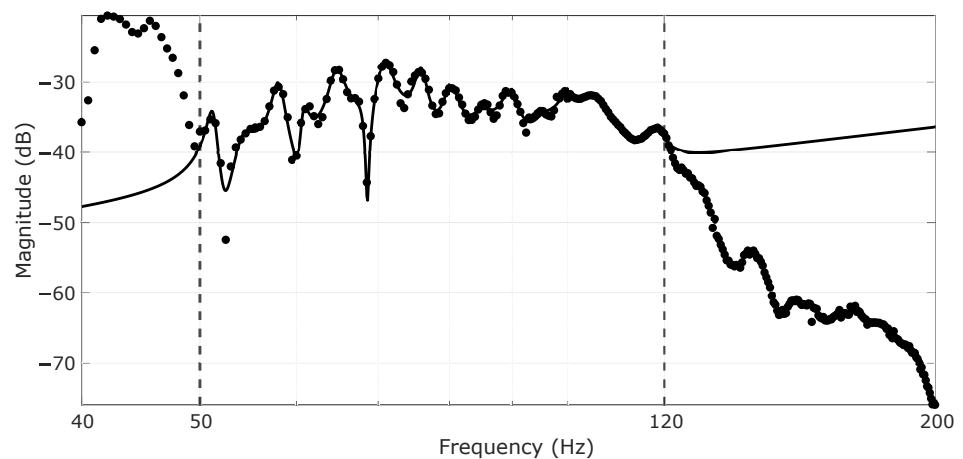

Figure 11. Results of channel characterization and modeling from [21]. The dots represent experimental measurements while the line represents the derived model.

4.2. Noise Characterization

Besides the frequency response of the channel, environmental noise that is present in the pipes is crucial for data communication reliability, since its presence decreases SNR. In UWSNs, background noise can result from the operation of pumps, the opening and closing of valves, vehicle traffic and nearby human activity. A characterization phase can be conducted to understand the noise levels present in the pipe. In [13], a noise measurement procedure was put in place. Acquisitions at different times of the day were transformed into the frequency domain to be compared amongst each other, as well as against the useful signal. Results showed significant fluctuations during the day. It was seen that the largest noise levels were at low frequencies, below 500 Hz. Similarly, in [21], a noise measurement campaign was performed over a 24 h interval. Measurements confirmed that the dominant noise is located at frequencies below 500 Hz. The results of the complete acquisition can be seen in Figure 12.

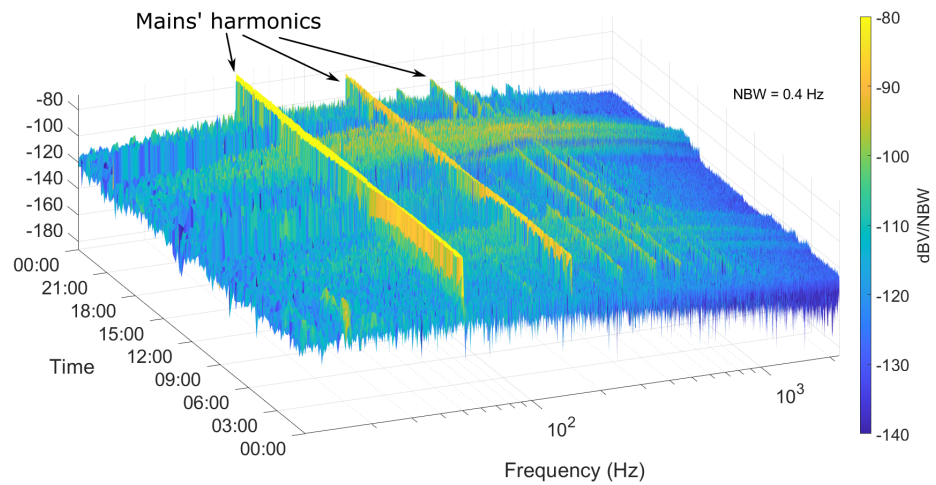

Figure 12. Results of noise acquisition campaign from [21].

In this case, some time intervals during the day showing increased noise levels, like between 15 and 18, were correlated with human activity near the pipeline, conversely from [13]. Comparing some slices of the noise spectra with the received signal during characterization, the plots in Figure 13 are achieved.

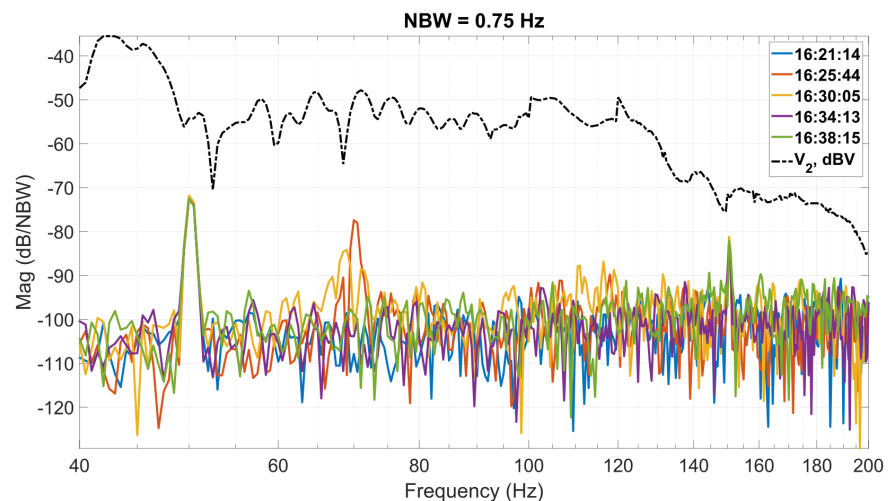

Figure 13. Comparison between received signal and noise levels in the pipe. Signal trace is in dBV as it is measured in single-tone conditions. Noise traces are amplitude densities and must be integrated over the desired bandwidth in order to provide absolute amplitudes. Each noise trace is identified by the acquisition time.

By considering a communication carrier frequency of 71 Hz, which is a local maximum, and taking the loudest of the noise records, an $SNR = 28$ dB was observed, yielding a theoretical BER:

$$BER = \frac{1}{2} \operatorname{erfc} \left(\sqrt{\frac{1}{2} 10^{\frac{SNR}{10}}} \right) = 3e - 139. \tag{6}$$

This value appears notably low as it is calculated under the assumption of unitary bandwidth efficiency and optimal detection. Its primary purpose is to serve as a reference for comparison with the BER computed earlier in Equation (3).

4.3. Communication Layer

Several undesirable features of the communication channel result from the characterization phase, which make the design and implementation of the communication system

challenging. Among these, the frequency response of the channel is found to be highly selective, with a small coherence bandwidth. This is related to the multi-path nature of the channel, which is due to a long delay spread [59]. Another challenge is represented by background noise, which is shown to be time-variant. Moreover, nonobserved phenomena such as possible variations in the channel frequency response with the properties of soil, the state of the pipelines, etc., should be investigated and taken into consideration. In [13], three digital modulation schemes were tested, namely Binary Amplitude Shift Keying (BASK), Binary Frequency Shift Keying (BFSK), and Binary Phase Shift Keying (BPSK). No information was provided about possible encoding techniques. The amplitude modulation scheme was used jointly with noncoherent demodulation, with the threshold set based on statistical analysis of the data. A data transmission success of over 70% was reported. Tests at any frequency other than 500 Hz led to the impossibility of data demodulation. In [21], the same binary digital modulation schemes were taken into consideration, and high-level simulations were carried out with the help of a vector-fitting time-invariant model of the characterized channel. In these simulations, noise was modeled as additive white Gaussian noise (AWGN), which is one of the most used models for communication channels [58]. The white noise adds to the frequency selectivity of the channel to impair the transmitted signal. Denoting the transmitted signal by $s_{TX}(t)$ and the added noise by $n(t)$, the received signal is given by

$$s_{RX}(t) = s_{TX}(t) * h(t) + n(t), \quad (7)$$

where $h(t)$ is the impulse response of the water channel. AWGN has a white spectrum, meaning that its power density $N(f)$ is constant with frequency. The total noise power is evaluated by integrating the noise power density over the entire bandwidth, as

$$P_N(t) = \int_0^{f_B} N(f) df. \quad (8)$$

The SNR can then be evaluated as [59]

$$SNR = 10 \log_{10} \left(\frac{P_S}{P_N} \right) \quad (9)$$

where P_S is the signal power. Simulation results showed that increasing the symbol time beyond the channel delay spread results in a decrease in BER [59]. This, however, also results in a decreased data rate. As the symbol time duration is decreased to increase the data rate, the BER varies with the carrier frequency and it is higher for frequencies at which the transfer function presents deep notches. This is related to the fact that at such frequencies the SNR decreases, but also the channel frequency response is less flat when compared to the local maxima, causing more distortion. It was also seen that adding a gap after transmitting each symbol helped mitigate the Intersymbol Interference (ISI), caused by the delayed arrivals through longer propagation paths. The BER performance was similar between BASK and BFSK modulations, where noncoherent threshold detection was employed in both cases. For the BFSK demodulation, two equal chains were needed, each centered around one of the carrier frequencies. The BPSK scheme with coherent demodulation showed better results [59]. However, the demodulation complexity is much higher with respect to the noncoherent schemes, and a reliable carrier recovery at such low frequencies and in such noisy environments is very challenging. For this reason, an OOK modulation with a time gap between symbols was implemented for the communication tests. In this modulation, the carrier-on time corresponding to a "one" symbol is smaller than the symbol time,

$$T_{HIGH} < T_{SYM}. \quad (10)$$

Simulations of the data transmission confirm the variation in the BER as T_{SYM} and T_{HIGH} are varied, as shown in Figures 14 and 15.

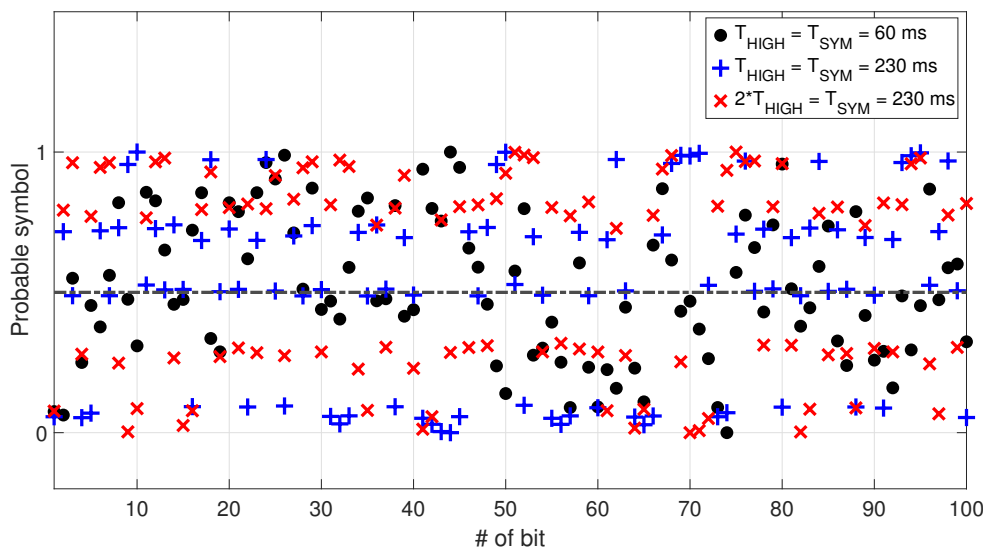

Figure 14. Simulation results for 100 transmitted bits. The plot shows the probable symbol at the output of the demodulator, employing OOK modulation and noncoherent demodulation. The frequency model shown in Figure 12 is used to simulate the channel. The dashed line represents the detection threshold.

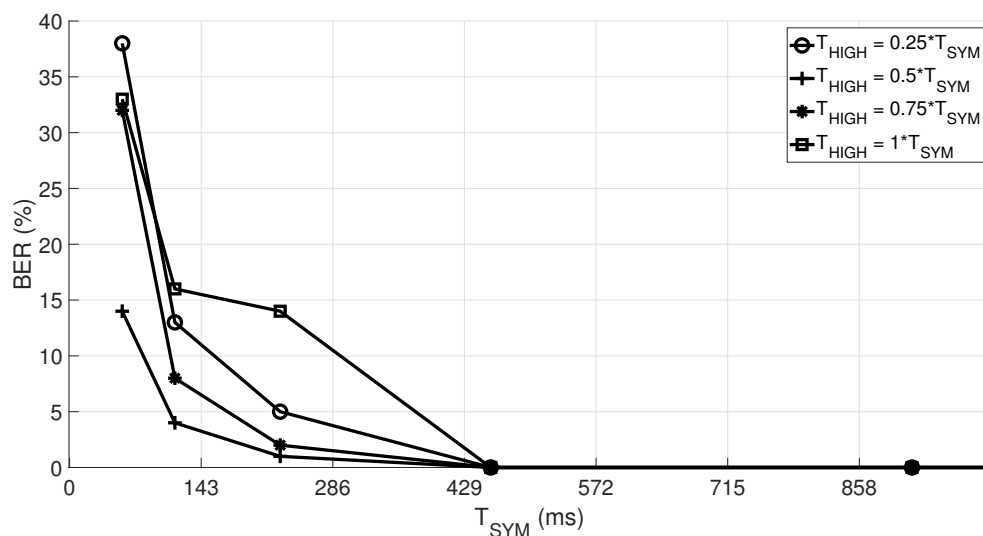

Figure 15. Simulation of BER dependence on T_{SYM} and T_{HIGH} .

In Figure 14, it can be seen that a better separation between probable “zeros” and probable “ones” is achieved when increasing T_{SYM} . The separation between probable symbols further improves when $T_{HIGH} = \frac{1}{2}T_{SYM}$. The BER plot of Figure 15 also reflects such dependence of the demodulated bits on T_{SYM} and T_{HIGH} . Aiming at improving the system performance, an 8-bit Cyclic Redundancy Code (CRC) was included in the packet structure, but no results regarding its experimental effectiveness were provided. Experimental results yielded successful half-duplex bidirectional data communication over a 73 m section of the water distribution pipeline. However, the low coherence bandwidth of the channel limited the data rate to 2.5 bps to achieve reliable communication.

5. Conclusions and Future Research Directions

SWGs have developed very quickly in the last few years, and acoustic-wave-based technology has arisen as a plausible communication technique among smart nodes deployed over a UWSN. Although SWGs based on acoustic wave communication have not

yet been reported, several works have investigated data transmission through water-filled pipes based on acoustic signals. This paper reviews these works in order to highlight the main design challenges and to identify future research developments.

To serve this scope, existing SWGs, based on traditional radio communication, were analyzed to highlight their key features. From this analysis, it emerged that existing SWGs employ sensors of pH, conductivity, temperature, ORP, turbidity as well as water level, flow, pressure and acoustic noise in order to monitor the water quality, pipeline health state, or both. In these contexts, it was found that a cost-convenient communication infrastructure between nodes employs a local area network which exchanges data with the internet through a gateway. The analysis showed that in practical water supply networks the distance between two nodes ranges from about 70 m up to 2 km. The time between two data transmissions can span up to 20 h in a real pipeline scenario.

Considering acoustic in-pipe communication systems, a literature review was carried out to check whether they can achieve the same communication distance and throughput as existing radio-based SWGs. From the review, it emerged that the majority of works considered performed experimental verification on ad hoc structures, over communication distances below 10 m. Since the focus of this review is on real, large-scale UWSNs, these research items have not been treated in detail. The only two works providing experimental results on large-scale UWSNs were found to be [13,21]. The distance covered was similar in both cases, around 70 m, which is comparable with that of standard-radio SWGs employing a local wireless network. The frequency band employed was around 500 Hz in [13], while [21] used a carrier frequency of 71 Hz. Such frequencies were chosen after measurement of the signal attenuation. Another main difference was the configuration of the acoustic actuator: while in [13] the actuator was externally mounted onto the pipe wall, the actuator in [21] was mounted so that its vibrating surface was in direct contact with water. Both works performed a noise characterization campaign, finding that the background noise is dominated by the low-frequency components, below 500 Hz. Finally, the implementation of the communication layer was similar, with both works employing amplitude modulation. Such modulation was used to maintain a low complexity, allowing the demodulation scheme to be implemented on a low-cost, low-power microcontroller.

The main design challenges observed were the severe frequency selectivity of the channel and the presence of time-varying ambient noise. The frequency selectivity is caused by the intrinsically meshed nature of UWSNs, which provides multiple paths for the signal to travel from the transmitter to the receiver. This feature causes a severe limitation in the data rate when using simple digital modulations. The presence of time-varying ambient noise might cause errors in the demodulation when a simple threshold detection scheme is employed. For this reason, future research on this topic should focus on the design of more sophisticated data modulation schemes or channel equalization techniques in order to cope with channel frequency selectivity. For example, spread spectrum modulation and Low-Density Parity Codes (LDPC) are promising solutions allowing one to improve the system performance significantly in terms of BER and throughput [61,62]. These modulation schemes have been addressed in other kinds of communications, but they have yet to be tested in large-scale UWSNs. Research should also be performed on making the demodulation process robust with respect to time-varying noise, so as to increase the communication reliability. Finally, an experimental assessment of the frequency response dependence on parameters such as the topology of the network, the geometry of the pipes and the properties of the surrounding soil should be performed.

The insights gained from the present review may be of assistance to researchers and practitioners to identify and tackle the major challenges in the design of a robust in-pipe acoustic communication system.

Author Contributions: Data curation, E.R.; investigation, M.F. and E.R.; writing M.F., E.R. and F.F.; supervision, F.F. All authors have read and agreed to the published version of the manuscript.

Funding: This research received no external funding.

Data Availability Statement: No new data were created or analyzed in this study. Data sharing is not applicable to this article.

Conflicts of Interest: The authors declare no conflict of interest.

References

1. Lalle, Y.; Fourati, M.; Fourati, L.C.; Barraca, J.P. Communication Technologies for Smart Water Grid Applications: Overview, Opportunities, and Research Directions. *Comput. Netw.* **2021**, *190*, 107940. [[CrossRef](#)]
2. Palermo, S.A.; Maiolo, M.; Brusco, A.C.; Turco, M.; Pirouz, B.; Greco, E.; Spezzano, G.; Piro, P. Smart Technologies for Water Resource Management: An Overview. *Sensors* **2022**, *22*, 6225. [[CrossRef](#)] [[PubMed](#)]
3. Tariq, S.; Hu, Z.; Zayed, T. Micro-Electromechanical Systems-Based Technologies for Leak Detection and Localization in Water Supply Networks: A Bibliometric and Systematic Review. *J. Clean. Prod.* **2021**, *289*, 125751. [[CrossRef](#)]
4. Bharani Baanu, B.; Jinesh Babu, K.S. Smart Water Grid: A Review and a Suggestion for Water Quality Monitoring. *Water Supply* **2021**, *22*, 1434–1444. [[CrossRef](#)]
5. Obeid, A.M.; Karray, F.; Jmal, M.W.; Abid, M.; Manzoor Qasim, S.; BenSaleh, M.S. Towards Realisation of Wireless Sensor Network-Based Water Pipeline Monitoring Systems: A Comprehensive Review of Techniques and Platforms. *IET Sci. Meas. Technol.* **2016**, *10*, 420–426. [[CrossRef](#)]
6. de Camargo, E.T.; Spanhol, F.A.; Slongo, J.S.; da Silva, M.V.R.; Pazinato, J.; de Lima Lobo, A.V.; Coutinho, F.R.; Pfrimer, F.W.D.; Lindino, C.A.; Oyamada, M.S.; et al. Low-Cost Water Quality Sensors for IoT: A Systematic Review. *Sensors* **2023**, *23*, 4424. [[CrossRef](#)]
7. Jo, W.; Hoashi, Y.; Paredes Aguilar, L.L.; Postigo-Malaga, M.; Garcia-Bravo, J.M.; Min, B.C. A Low-Cost and Small USV Platform for Water Quality Monitoring. *HardwareX* **2019**, *6*, e00076. [[CrossRef](#)]
8. Sitaropoulos, K.; Salamone, S.; Sela, L. Frequency-Based Leak Signature Investigation Using Acoustic Sensors in Urban Water Distribution Networks. *Adv. Eng. Inform.* **2023**, *55*, 101905. [[CrossRef](#)]
9. Giurgiutiu, V. *Structural Health Monitoring with Piezoelectric Wafer Active Sensors*; Academic Press: Amsterdam, The Netherlands, 2014.
10. Su, Z.; Ye, L. *Identification of Damage Using Lamb Waves: From Fundamentals to Applications*; Number 48 in Lecture Notes in Applied and Computational Mechanics; Springer: Berlin, Germany, 2009.
11. He, S.; Wang, N.; Ho, M.; Zhu, J.; Song, G. Design of a New Stress Wave Communication Method for Underwater Communication. *IEEE Trans. Ind. Electron.* **2021**, *68*, 7370–7379. [[CrossRef](#)]
12. Jing, L.; Li, Z.; Li, Y.; Murch, R.D. Channel Characterization of Acoustic Waveguides Consisting of Straight Gas and Water Pipelines. *IEEE Access* **2018**, *6*, 6807–6819. [[CrossRef](#)]
13. Joseph, K.M.; Watteyne, T.; Kerkez, B. Awa: Using Water Distribution Systems to Transmit Data: Awa: Using to Transmit Data. *Trans. Emerg. Telecommun. Technol.* **2018**, *29*, e3219. [[CrossRef](#)]
14. Kokossalakis, G. Acoustic Data Communication System for In-Pipe Wireless Sensor Networks. Ph.D. Thesis, Massachusetts Institute of Technology, Cambridge, MA, USA, 2006.
15. Sakuma, H.; Nakamura, K.; Ueha, S. Two-Way Communication over Gas Pipe-Line Using Multicarrier Modulated Sound Waves with Cyclic Frequency Shifting. *Acoust. Sci. Technol.* **2006**, *27*, 225–232. [[CrossRef](#)]
16. Kantaris, G.S.; Makris, N.A. Underwater Wireless In-Pipe Communications System. In Proceedings of the 2015 IEEE International Conference on Industrial Technology (ICIT), Seville, Spain, 17–19 March 2015; pp. 1945–1950. [[CrossRef](#)]
17. Joseph, K.M.; Kerkez, B. Enabling Communications for Buried Pipe Networks. In Proceedings of the World Environmental and Water Resources Congress, Portland, OR, USA, 1–5 June 2014; American Society of Civil Engineers: Reston, VA, USA, 2014; pp. 899–910. [[CrossRef](#)]
18. Farai, O.; Metje, N.; Anthony, C.; Chapman, D. Analysis of Acoustic Signal Propagation for Reliable Digital Communication along Exposed and Buried Water Pipes. *Appl. Sci.* **2023**, *13*, 4611. [[CrossRef](#)]
19. Afkhami Meybodi, S.; Pardo, P.; Dohler, M. Magneto-Inductive Communication among Pumps in a District Heating System. In Proceedings of the 9th International Symposium on Antennas, Propagation and EM Theory, Guangzhou, China, 29 November–2 December 2010; pp. 375–378. [[CrossRef](#)]
20. Wang, M.; Jing, L.; Lu, Y.; Stojanovic, M.; Murch, R. Performance of Coherent OFDM and Differentially Coherent OFDM Communication Systems in Water Pipeline Channels. In Proceedings of the Global Oceans 2020: Singapore U.S. Gulf Coast, Biloxi, MS, USA, 5–30 October 2020; pp. 1–4. [[CrossRef](#)]
21. Fishta, M.; Raviola, E.; Fiori, F. A Wireless Communication System for Urban Water Supply Networks Based on Guided Acoustic Waves. *IEEE Access* **2022**, *10*, 108955–108964. [[CrossRef](#)]
22. Heifetz, A.; Shribak, D.; Huang, X.; Wang, B.; Saniee, J.; Young, J.; Bakhtiari, S.; Vilim, R.B. Transmission of Images with Ultrasonic Elastic Shear Waves on a Metallic Pipe Using Amplitude Shift Keying Protocol. *IEEE Trans. Ultrason. Ferroelectr. Freq. Control* **2020**, *67*, 1192–1200. [[CrossRef](#)] [[PubMed](#)]
23. Chakraborty, S.; Saulnier, G.J.; Wilt, K.W.; Curt, E.; Scarton, H.A.; Litman, R.B. Low-Power, Low-Rate Ultrasonic Communications System Transmitting Axially along a Cylindrical Pipe Using Transverse Waves. *IEEE Trans. Ultrason. Ferroelectr. Freq. Control* **2015**, *62*, 1788–1796. [[CrossRef](#)] [[PubMed](#)]

24. Kumar, L.S.; Han, W.K.; Guan, Y.L.; Lee, Y.H.; Sun, S. Optimization of Acoustic Communication for Industrial Drilling. In Proceedings of the 2013 IEEE Conference on Information Communication Technologies, Thuckalay, India, 11–12 April 2013; pp. 1060–1063. [\[CrossRef\]](#)
25. Su, N.; Liu, J.; Liu, Q.; Wang, W. A Robust Underwater Acoustic Communication Approach for Pipeline Transmission. In Proceedings of the 2016 IEEE International Conference on Signal Processing, Communications and Computing (ICSPCC), Hong Kong, China, 5–8 August 2016; pp. 1–6. [\[CrossRef\]](#)
26. Wei, D.; Qi, C.; Huang, C.; Chen, J.; Song, A.; Song, G.; Pan, M. Riding Stress Wave: Underwater Communications Through Pipeline Networks. *IEEE J. Ocean. Eng.* **2021**, *46*, 1450–1462. [\[CrossRef\]](#)
27. He, S.; Zhang, G.; Song, G. Design of a Networking Stress Wave Communication Method along Pipelines. *Mech. Syst. Signal Process.* **2022**, *164*, 108192. [\[CrossRef\]](#)
28. Tuptuk, N.; Hazell, P.; Watson, J.; Hailes, S. A Systematic Review of the State of Cyber-Security in Water Systems. *Water* **2021**, *13*, 81. [\[CrossRef\]](#)
29. Di Nardo, A.; Boccelli, D.L.; Herrera, M.; Creaco, E.; Cominola, A.; Sitzenfren, R.; Taormina, R. Smart Urban Water Networks: Solutions, Trends and Challenges. *Water* **2021**, *13*, 501. [\[CrossRef\]](#)
30. Rouso, B.Z.; Lambert, M.; Gong, J. Smart Water Networks: A Systematic Review of Applications Using High-Frequency Pressure and Acoustic Sensors in Real Water Distribution Systems. *J. Clean. Prod.* **2023**, *410*, 137193. [\[CrossRef\]](#)
31. Khoa Bui, X.; S. Marlim, M.; Kang, D. Water Network Partitioning into District Metered Areas: A State-Of-The-Art Review. *Water* **2020**, *12*, 1002. [\[CrossRef\]](#)
32. Lai, T.T.T.; Chen, W.J.; Li, K.H.; Huang, P.; Chu, H.H. TriopusNet: Automating Wireless Sensor Network Deployment and Replacement in Pipeline Monitoring. In Proceedings of the 11th International Conference on Information Processing in Sensor Networks, Beijing, China, 16–20 April 2012; Association for Computing Machinery: New York, NY, USA, 2012; pp. 61–72. [\[CrossRef\]](#)
33. Allen, M.; Preis, A.; Iqbal, M.; Whittle, A.J. Water Distribution System Monitoring and Decision Support Using a Wireless Sensor Network. In Proceedings of the 2013 14th ACIS International Conference on Software Engineering, Artificial Intelligence, Networking and Parallel/Distributed Computing, Honolulu, HI, USA, 1–3 July 2013; pp. 641–646. [\[CrossRef\]](#)
34. Alves, A.J.R.; Manera, L.T.; Campos, M.V. Low-Cost Wireless Sensor Network Applied to Real-Time Monitoring and Control of Water Consumption in Residences. *Rev. Ambiente Água* **2019**, *14*, e2407. [\[CrossRef\]](#)
35. Chinnusamy, S.; Mohandoss, P.; Paul, P. IoT Enabled Monitoring and Control of Water Distribution Network. In Proceedings of the WDSA / CCWI Joint Conference, Kingston, ON, Canada, 23–25 July 2018.
36. Cai, L.; Wang, R.; Ping, J.; Jing, Y.; Sun, J. Water Supply Network Monitoring Based on Demand Reverse Deduction (DRD) Technology. *Procedia Eng.* **2015**, *119*, 19–27. [\[CrossRef\]](#)
37. Christodoulou, S. Wireless Sensor Networks for Water Loss Detection. *Eur. Water* **2010**, *30*, 41–48.
38. Cloete, N.A.; Malekian, R.; Nair, L. Design of Smart Sensors for Real-Time Water Quality Monitoring. *IEEE Access* **2016**, *4*, 3975–3990. [\[CrossRef\]](#)
39. Fuentes, H.; Mauricio, D. Smart Water Consumption Measurement System for Houses Using IoT and Cloud Computing. *Environ. Monit. Assess.* **2020**, *192*, 602. [\[CrossRef\]](#)
40. Lambrou, T.P.; Anastasiou, C.C.; Panayiotou, C.G.; Polycarpou, M.M. A Low-Cost Sensor Network for Real-Time Monitoring and Contamination Detection in Drinking Water Distribution Systems. *IEEE Sens. J.* **2014**, *14*, 2765–2772. [\[CrossRef\]](#)
41. Machell, J.; Mounce, S.R.; Boxall, J.B. Online Modelling of Water Distribution Systems: A UK Case Study. *Drink. Water Eng. Sci.* **2010**, *3*, 21–27. [\[CrossRef\]](#)
42. Pérez-Padillo, J.; Puig, F.; García Morillo, J.; Montesinos, P. IoT Platform for Failure Management in Water Transmission Systems. *Expert Syst. Appl.* **2022**, *199*, 116974. [\[CrossRef\]](#)
43. Stephens, M.; Gong, J.; Zhang, C.; Marchi, A.; Dix, L.; Lambert, M.F. Leak-Before-Break Main Failure Prevention for Water Distribution Pipes Using Acoustic Smart Water Technologies: Case Study in Adelaide. *J. Water Resour. Plan. Manag.* **2020**, *146*, 05020020. [\[CrossRef\]](#)
44. Verma, P.; Kumar, A.; Rathod, N.; Jain, P.; Mallikarjun, S.; Subramanian, R.; Amrutur, B.; Kumar, M.S.M.; Sundaresan, R. Towards an IoT Based Water Management System for a Campus. In Proceedings of the 2015 IEEE First International Smart Cities Conference (ISC2), Guadalajara, Mexico, 25–28 October 2015; pp. 1–6. [\[CrossRef\]](#)
45. Das, B.; Jain, P. Real-Time Water Quality Monitoring System Using Internet of Things. In Proceedings of the 2017 International Conference on Computer, Communications and Electronics (Comptelix), Jaipur, India, 1–2 July 2017; pp. 78–82. [\[CrossRef\]](#)
46. Simitha, K.M.; Raj, S. IoT and WSN Based Water Quality Monitoring System. In Proceedings of the 2019 3rd International Conference on Electronics, Communication and Aerospace Technology (ICECA), Coimbatore, India, 12–14 June 2019; pp. 205–210. [\[CrossRef\]](#)
47. Priya, S.K.; Shenbagalakshmi, G.; Revathi, T. Design of Smart Sensors for Real Time Drinking Water Quality Monitoring and Contamination Detection in Water Distributed Mains. *Int. J. Eng. Technol.* **2018**, *7*, 47–51. [\[CrossRef\]](#)
48. Saravanan, K.; Anusuya, E.; Kumar, R.; Son, L.H. Real-Time Water Quality Monitoring Using Internet of Things in SCADA. *Environ. Monit. Assess.* **2018**, *190*, 556. [\[CrossRef\]](#)

49. Anjana, S.; Sahana, M.N.; Ankith, S.; Natarajan, K.; Shobha, K.R.; Paventhan, A. An IoT Based 6LoWPAN Enabled Experiment for Water Management. In Proceedings of the 2015 IEEE International Conference on Advanced Networks and Telecommunications Systems (ANTS), Kolkata, India, 15–18 December 2015; pp. 1–6. [\[CrossRef\]](#)
50. Stoianov, I.; Nachman, L.; Madden, S.; Tokmouline, T.; Csail, M. PIPENET: A Wireless Sensor Network for Pipeline Monitoring. In Proceedings of the 2007 6th International Symposium on Information Processing in Sensor Networks, Cambridge, MA, USA, 25–27 April 2007; pp. 264–273. [\[CrossRef\]](#)
51. Lewandowski, M.; Płaczek, B. Data Transmission Reduction in Wireless Sensor Network for Spatial Event Detection. *Sensors* **2021**, *21*, 7256. [\[CrossRef\]](#)
52. Chitre, M.; Shahabudeen, S.; Stojanovic, M. Underwater Acoustic Communications and Networking: Recent Advances and Future Challenges. *Mar. Technol. Soc. J.* **2008**, *42*, 103–116. [\[CrossRef\]](#)
53. Akyildiz, I.F.; Pompili, D.; Melodia, T. Underwater Acoustic Sensor Networks: Research Challenges. *Ad Hoc Netw.* **2005**, *3*, 257–279. [\[CrossRef\]](#)
54. Rice, J.; Green, D. Underwater Acoustic Communications and Networks for the US Navy’s Seaweb Program. In Proceedings of the 2008 Second International Conference on Sensor Technologies and Applications (Sensorcomm 2008), Cap Esterel, France, 25–31 August 2008; pp. 715–722. [\[CrossRef\]](#)
55. Pierce, A.D. *Acoustics: An Introduction to Its Physical Principles and Applications*; Springer International Publishing: Cham, Switzerland, 2019. [\[CrossRef\]](#)
56. Howard, C.; Cazzolato, B. *Acoustic Analyses Using Matlab and Ansys*, 1st ed.; CRC Press: Boca Raton, FL, USA, 2014. [\[CrossRef\]](#)
57. Fishta, M.; Raviola, E.; Fiori, F.; Calza, F.; Tornaboni, A. Experimental Characterization of In-Pipe Acoustic Communication Channels Through Measurement of Pressure Transfer Functions. In Proceedings of the 2022 IEEE 27th International Conference on Emerging Technologies and Factory Automation (ETFA), Stuttgart, Germany, 6–9 September 2022; pp. 1–7. [\[CrossRef\]](#)
58. Proakis, J.G.; Salehi, M. *Digital Communications*, 5th ed.; McGraw-Hill: New York, NY, USA, 2008.
59. McCune, E. *Practical Digital Wireless Signals*, 1st ed.; The Cambridge RF and Microwave Engineering Series; Cambridge Univ. Press: Cambridge, UK, 2010.
60. Fishta, M.; Raviola, E.; Fiori, F. A Baseband Wireless VNA for the Characterization of Multiport Distributed Systems. *IEEE Trans. Instrum. Meas.* **2023**, *72*, 1–8. [\[CrossRef\]](#)
61. Shao, S.; Hailes, P.; Wang, T.Y.; Wu, J.Y.; Maunder, R.G.; Al-Hashimi, B.M.; Hanzo, L. Survey of Turbo, LDPC, and Polar Decoder ASIC Implementations. *IEEE Commun. Surv. Tutor.* **2019**, *21*, 2309–2333. [\[CrossRef\]](#)
62. Chen, P.; Shi, L.; Fang, Y.; Lau, F.C.M.; Cheng, J. Rate-Diverse Multiple Access Over Gaussian Channels. *IEEE Commun. Surv. Tutor.* **2023**, *22*, 5399–5413. [\[CrossRef\]](#)

Disclaimer/Publisher’s Note: The statements, opinions and data contained in all publications are solely those of the individual author(s) and contributor(s) and not of MDPI and/or the editor(s). MDPI and/or the editor(s) disclaim responsibility for any injury to people or property resulting from any ideas, methods, instructions or products referred to in the content.