

The Cognitive Principle of Relevance and its Application to Anti Iraq War Posters

المبدأ الإدراكي في نظرية الترابط بالموضوع وتطبيقاته على الملصقات
الجدارية التي تعكس معارضة الحرب على العراق

Prof. Dr.

Freed H. Al-Hindawi

University of Babylon

Asst. Prof. Rufaidah Kamal Abdulmajeed

College of Education for Women-

Baghdad University

Abstract

Relevance theory is a psychological model for understanding the cognitive interpretation of language, was developed by Dan Sperber and Deirdre Wilson in 1986 and republished in 1995. They argue that the thing that causes an input to stand out from others is its relevance to the receiver and that every utterance creates in the addressee an expectation of relevance. The underlying assumption of relevance theory is that in any given context, the addressee has to assume that what people say is relevant.

In this paper the problem of the cognitive principle of relevance theory presented by Sperber and Wilson is approached in its application to the posters painted by people who are opposing an American led war against Iraq. The analysis will be conducted to find out how these posters achieve a successful communication and how is that the audience recognizes that the designer of each poster has something to say that matters, something that is relevant and how the addressee understands the content of these posters and how he/she uses their cognition to interpret the posters' contents and finds them relevant as they are apposing the war against Iraq.

Introduction

According to Sperber and Wilson, pragmatics needs only one principle, that of relevance, which says that every utterance creates in the

The Cognitive Principle of Relevance and its Application.....(10)

addressee an expectation of relevance. The underlying assumption of relevance theory is that in any given context, the addressee has to assume that what people say is relevant. (Sperber and Wilson, 1986: 161)

They characterize relevance as a property of inputs to cognitive processes which makes them worth processing. ('Relevance' is used in a technical sense which is not meant to capture any of the ordinary senses of the word.) These inputs may be external stimuli (e.g. a smell, the sound of an utterance), or internal representations which may undergo further processing (e.g. the recognition of a smell, a memory, the linguistic decoding of an utterance). At each point in our cognitive lives, there are many more potential inputs available than we can actually process: for example, we perceive many more distal stimuli than we can attend to, and have many more memories than we can reactivate at a single time. Efficiency in cognition is largely a matter of allocating our processing resources so as to maximise cognitive benefits.

This theory stands opposed to classical code model whereby information is encoded into a message, transmitted and decoded by another party, with another copy of the code. The inferential model of communication, which is considered as an alternative to the classical code model means that a communicator encodes his/her intended message into a signal, which is decoded by the audience using an identical copy of the code. According to the inferential model, a communicator provides an evidence of his/her intention to convey a certain meaning, which is inferred by the audience on the basis of the evidence provided.

This paper is devoted to apply the cognitive principle of relevance theory presented by Sperber and Wilson in (1986) to the posters selected from a website designed to be a gallery of posters done by people who are opposing an American led war against Iraq. The analysis will be conducted to find out how these posters achieve a successful communication and how is that the audience recognizes that the designer of each poster has something to say that matters, something that is relevant and how the addressee understands the content of each poster and how he/she uses their cognition to interpret the content of each poster and finds it relevant as they are opposing the war against Iraq.

What is Relevance Theory?

Relevance theory, first proposed by Daniel Sperber and Deirdre Wilson in 1986 and republished in 1995, is a psychological model for

The Cognitive Principle of Relevance and its Application.....(11)

understanding the cognitive interpretation of language. It stands on the opposite side of theories of communication in pragmatics. While the speech act theory and Grice's Cooperation Principle provide useful tools to account for how people interact with each other, this theory deals with the cognitive side of interaction and, as it is claimed by Sperber and Wilson, it is incompatible with those above mentioned theories.

As Sperber and Wilson (1986: 163) remark, "the realization that a trust worthy communicator intends to make you believe something is an excellent reason for believing it".

The purpose of communication, according to the relevance theory, is not to 'duplicate thoughts', but to 'enlarge mutual cognitive environment.' (ibid.: 193)

They (ibid.:3) propose the code model and the semiotic approach to communication. This code is:

a system which pairs messages with signals, enabling two information-processing devices (organisms or machines) to communicate. A message is a representation internal to the communicating devices. A signal is a modification of the external environment which can be produced by one device and recognised by the other.

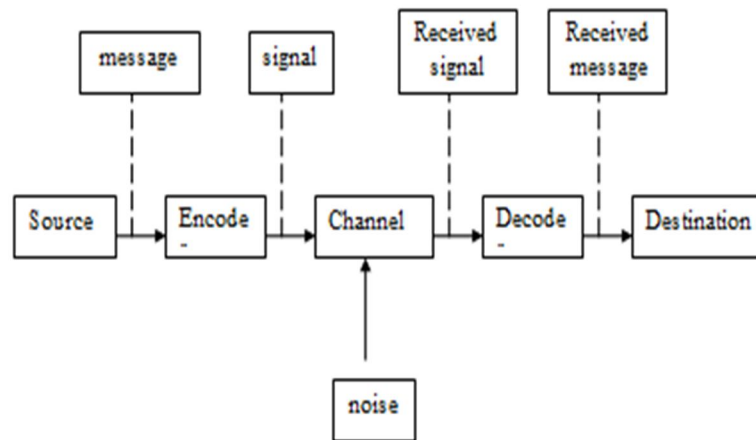

Figure no. (1) Sperber and Wilson (1995: 4)

This diagram shows how a message originating in an information source can be duplicated at a destination as the result of a communication process. (ibid.) It is slightly adopted from Shannon & Weaver information theory (1949):

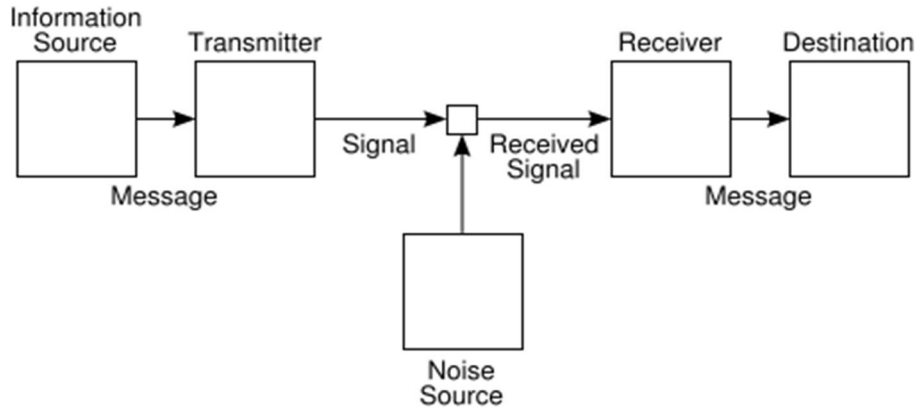

Figure no. (2) Shannon & Weaver Information Theory (1949)

This diagram refers to the information source, which selects a desired message out of a set of possible messages. The selected message may consist of written or spoken words, or of pictures, music, etc. The transmitter changes this message into the signal which is actually sent over the communication channel from the transmitter to the receiver.

They propose a “Principle of Relevance”, which reads as “every act of ostensive communication communicates a presumption of its own optimal relevance.” (Sperber and Wilson, 1995: 158)

By ‘ostensive communication’ they mean that:

The communicator produces a stimulus which makes it mutually manifest to communicator and audience that the communicator intends, by means of this stimulus, to manifest or more manifest to the audience a set of assumptions

(ibid.: 63)

They call this as “ostensive-inferential communication”, too, since the communicator considers it ostention, while inference takes place on the part of the audience. (ibid.: 54)

The notion of being “manifest” is weaker than “known”, so a “fact can be manifest without being known.” (ibid.: 40) They abandon the idea of ‘mutual knowledge’ or ‘shared information’, which is often considered to be important in communication, because every individual has a slightly different mental representation despite of sharing the same physical environment. Instead, they propose the notion of ‘mutual manifestation’.

They propose two kinds of the speaker’s intention:

The Cognitive Principle of Relevance and its Application.....(13)

Informative intention: to make manifest or more manifest to the audience a set of assumptions.

(ibid.: 58)

Communicative intention: to make it mutually manifest to audience and communicator that the communicator has this informative intention.

(ibid.: 61)

They (ibid.: 119) claim that the word 'Relevance' is a fuzzy term, used differently by different people or by the same people at different times. It does not have a translation in every human language. There is no reason to think that a proper semantic analysis of the English word 'relevance' would also characterise a concept of scientific psychology". Then, they say that "It might be tempting, then, to propose the following definition: An assumption is relevant in a context if and only if it has some contextual effect in that context."(ibid.) This definition refers to the intuition that to be relevant in a context, an assumption must be connected up with that context in some way. (ibid.: 122).

This definition of relevance, using their words, is insufficient for at least two reasons:

first relevance is a matter of degree, and we have said nothing about how degrees of relevance are determined; second, because we have defined relevance as a relation between an assumption and a context, but have said nothing about how the context is determined. At the moment, then, we have simply defined a formal property, whose relation to psychological reality has been left undescribed. (ibid.:123)

They (ibid.) assume that people have intuitions of relevance: that they can consistently distinguish relevant from irrelevant information, or in some cases, more relevant from less relevant information.

Sperber and Wilson, (1995: 118) discussed the variety of the contextual effects as: contextual implications, contradictions, and strengthenings. The notion of a 'contextual effect' is essential to a description of the comprehension process. As a discourse proceeds, the hearer retrieves or constructs and then processes a number of assumptions. These form a gradually changing background against which new information is processed. They (ibid.: 119) add that "the notion of a contextual effect is essential to a characterisation of relevance". They argue that having contextual effects is a necessary condition for

The Cognitive Principle of Relevance and its Application.....(14)

relevance, and that other things being equal, the greater the contextual effects, the greater the relevance.

There are thus three types of case in which an assumption may lack contextual effects, and be irrelevant, in a context. In the first, the assumption may contribute new information; but this information does not connect up with any information present in the context. In the second, the assumption is already present in the context and its strength is unaffected by the newly presented information; this newly presented information is therefore entirely uninformative and irrelevant. In the third type of case, the assumption is inconsistent with the context and is too weak to upset it. (ibid.:121) Perceiving some contextual effect of an assumption seems to be sufficient for judging it relevant.

Other relevance theorists take part in demonstrating it. This theory, according to Crystal (2003: 395), is the theory of communication and cognition based on the claim that human cognition is geared to the maximizing of relevance. He agrees with Sperber and Wilson in that the old information interacts with the new information to produce various contextual effects, and more contextual effects it produces, the more relevant it is. On the other hand, the more processing effort it involves, the less relevant it is, whereas Yus (2006: 854) tends to summarize the basic assumptions of this theory:

1. The decoded meaning of the sentence is compatible with a number of different interpretations in the same context.
2. These interpretations are graded in terms of accessibility.
3. Hearers rely on a powerful criterion when selecting the most appropriate interpretation.
4. This criterion makes it possible to select one interpretation among the range of possible interpretations, to the extent that when a first interpretation is considered a candidate matching the intended interpretation, the hearer will stop at this point.

Mey (2009: 855), on the other hand, says that the relevance theory is not only a typical property of external stimuli (e.g. utterances) but also of internal representations and thoughts, all of which may become input for cognitive processing. The pursuit of relevance is a typical aspect of the mental activity of human beings, always geared to obtaining the highest reward from the stimuli that they possess.

Furthermore, Trask, (1999: 85) (Cited in Cutting, 2008: 41) extends this theory and says that the less effort it takes to recover a fact, the greater the relevance. The speaker assumes which facts are accessible for

The Cognitive Principle of Relevance and its Application.....(15)

the hearer and speaks in such way that the hearer can make the correct inferences without too much effort. The context of the utterance is chosen by the hearer. The hearer interprets what is said by finding an accessible context that produces the maximum amount of new information with 'the minimum amount of processing effort.'

In an understanding of the functioning of language, Verschueren, (1999: 263) argues that in an attempt to recapture unity of topic and methods, tight restrictions are imposed by relevance theory which limits pragmatics to whatever can be said in terms of a cognitively defined notion of relevance.

The next section will reveal the relationship of the relevance theory with Grice's maxim of relation.

Relevance Theory and Grice's Maxims:

One may ask what is the difference between Grice's (1975) Maxim of Relevance and 'Relevance Theory'?

Sperber and Wilson claim that Grice's (1975) four maxims are not necessary, but only one maxim or 'relevance' is enough to account for every kind of communication. The following is what they consider as 'relevance'.

Extent condition 1: an assumption is relevant in a context to the extent that its contextual effects in this context are large.

Extent condition 2: an assumption is relevant in a context to the extent that the effort required to process it in this context is small.

(Sperber and Wilson, 1995: 125)

Relevance theory, as a cognitive theory of human communication functions as a cognitive-centered, is considered as an alternative to Grice's cooperative principle. By proposing his maxims; 1- Maxim of Quality (truthfulness), Of Quantity (informativeness), of relation (Relevance) and of Manner, (clarity), Grice provides the foundation for the relevance theory.

Okada (2001: 167) makes a list of differences between Sperber and Wilson's principle of relevance and Grice's maxims as follows:

- Sperber and Wilson principle is a generalization about ostensive-inferential communication (both explicit and implicit), not a set of rules that people have to 'observe' as Grice's.
- Their principle is much more explicit than Grice's.
- Their principle covers all Grice's notions.

The Cognitive Principle of Relevance and its Application.....(16)

- Grice assumes a greater degree of co-operation in communication than they do.

Sperber and Wilson criticize Grice's notion of 'explicit communication'. Instead, they produce the notion of 'explicature' and 'implicature'. The former notion is defined as "an assumption communicated by an utterance U is explicit if and only if it is a development of a logical form encoded by U," while the latter notion is defined as "any assumption communicated, but not explicitly so, is implicitly communicated. (Sperber and Wilson, 1995: 182)

They (ibid.: 193) say that conversational implicature is understood by hearers simply by selecting the relevant features of context and recognizing whatever speakers say as relevant to the conversation. When hearers and readers make sense of a text, they interpret the connections between utterances as meaningful, making inferences by drawing on their own background knowledge of the world.

They, further, propose two kinds of implicatures, they are 'implicated premises' and 'implicated conclusion'. In their example, when Peter says to Mary, "Would you drive a Mercedes?", and May answers him, "I wouldn't drive ANY expensive car", then the assumption, "A Mercedes is an expensive car" is an 'implicated premise'; whereas the 'implicated conclusion' is "Mary wouldn't drive a Mercedes." (ibid.: 194)

Their other contribution is their notion of 'strong' and 'weak' implicatures (ibid.: 199). In the above example, the 'implicated premise' and the 'implicated conclusion' are the strongest and determinate implicatures. On the other hand, the 'weak' implicatures are where "the hearer receives no encouragement at all to supply any particular premise and conclusion, and he takes the entire responsibility for supplying them himself." (ibid.)

Other relevance theorists, May, (1993: 80) for example, share Grice's intuition that utterance raise expectations of relevance. He argues that relevance is the potential property of thoughts, memories and conclusions of inferences, i.e. any external stimulus or internal representation which provides an input to cognitive processes may be relevant to an individual at some time. Every utterance creates in the addressee an expectation of relevance. "The underlying assumption of relevance, that in any given context, we have to assume that what people say is relevant". In another sense, "achieving successful communication is a sufficient aim in conversation or other verbal interaction." (ibid.)

The Cognitive Principle of Relevance and its Application.....(17)

Lenk (1998: 22), on the other hand, states that Sperber and Wilson's Relevance Theory reduces Grice's four conversational maxims to the one single maxim "Be relevant". He continues that Sperber and Wilson hold that in an appropriate conversational context, three out of the four conversational maxims, namely, the Maxims of Quality, Quantity, and Manner can be violated without necessarily resulting in a breakdown of communication. The only conversational maxim that cannot be violated without an immediate breakdown of communication is the 'Maxim of Relevance'. (ibid.)

The Main Principles of the Relevance Theory

The relevance theory can be divided into two sets of principles:

- 1- Principle of Communication.
- 2- Principle of cognition.

In the Communicative Principle of Relevance, every utterance conveys a presumption of its own optimal relevance. In interpreting an utterance, the hearer invariably has to go beyond the linguistically-encoded sentence meaning. There will be ambiguities and referential indeterminacies to resolve, and other under determinate aspects of explicit content that we will look at briefly.

The Communicative Principle of Relevance and the definition of optimal relevance suggest a practical procedure for constructing a hypothesis about the speaker's meaning. The hearer should consider interpretive hypotheses (disambiguations, reference assignments, implicatures, etc.) in order of accessibility-that is, follow a path of least effort-and stop when he arrives at an interpretation which satisfies the expectations of relevance raised by the utterance itself. (Wilson and Sperber, 2002: 583-632)

Relevance theorists make reference to the overt or public nature of the speaker's communicative intentions in certain acts of communications. Communication will be successful and understanding will occur when the addressee recognizes these intentions. This process is mostly inferential and it has costs. When someone utters something with a communicative purpose, he does it, according to relevance theory, with the presumption of optimal relevance which states that:

- a. The utterance is relevant enough to be worth processing.
- b. It is the most relevant on compatible with the communicator's abilities and preferences.

The Cognitive Principle of Relevance and its Application.....(18)

For (a), the audience can expect the ostensive utterance to be relevant enough to be worth processing, and (b) means communicators cannot be expected to go against their own interest and preferences in producing an utterance. There may be relevant information that they are unable or unwilling to provide, and ostensive stimuli that would convey their intentions more economically, but that they are unable to produce, or unwilling to think of at the time. (Wilson and Sperber, 2006: 612)

The main concern of the present study is with principle of cognition. Therefore, the following section will be devoted for this principle.

The Cognitive Principle of Relevance

At the centre of the hard core of relevance theory are the cognitive principle of relevance and the definition of relevance as a trade-off of cognitive benefit against processing cost. The cognitive principle is the hypothesis that cognitive systems tend to maximize relevance. Human cognition tends to be geared to the maximization of relevance. (Sperber & Wilson, 1986: 260)

The Cognitive Principle of Relevance, which is the claim that cognition tends to maximize relevance and the views that cognition is a matter of computations over mental representations, and that human beings possess a 'deductive device' which plays a central role in spontaneous inference.

Relevance theory is a framework for the study of cognition, proposed primarily in order to provide a psychologically realistic account of communication.

The central claim of relevance theory is that, "as a result of constant selection pressures, the human cognitive system has developed a variety of dedicated (innate or acquired) mental mechanisms or biases which tend to allocate attention to inputs with the greatest expected relevance, and process them in the most relevance-enhancing way". (Wilson, 2009: 394)

'Relevance' here is defined as a property of inputs to cognitive systems: an input is more relevant the more cognitive effects it yields, and less relevant the more mental effort it takes to process. The cognitive principle is the claim that human cognitive systems tend to work with their input in such a way as to yield the maximum cognitive benefit for the least mental effort. The cognitive systems include (at least) those that are centrally involved in perception; memory and reasoning as well as those that underpin the production and interpretation of utterances.

The Cognitive Principle of Relevance and its Application.....(19)

The human cognitive system tends towards processing the most relevant inputs available. The tendency described in the Cognitive Principle of Relevance is strong enough, and manifest enough, to make our mental processes at least partially predictable to others. We are in general fairly good at predicting which of the external stimuli currently affecting some other individual's nervous system he is likely to be attending to, and which of the indefinitely many conclusions that he might draw from it he will in fact draw. What we do, essentially, is assume that he will pay attention to the potentially most relevant stimulus, and process it so as to maximize its relevance: that is, in a context of easily accessible back-ground assumptions, where the information it provides will carry relatively rich cognitive effects. (Wilson and Sperber, 2002, pp. 583-632)

Wilson and Sperber (2006: 610) in their article Relevance Theory discuss cognitive principle as:

Intuitively, an input (a sight, a sound, an utterance, a memory) is relevant to an individual when it connects with background information he has available to yield conclusions that matter to him: say, by answering a question he had in mind, improving his knowledge on a certain topic, settling a doubt, confirming a suspicion, or correcting a mistaken impression.

They further add that the cognitive principle of relevance is very important because the universal cognitive tendency to maximize relevance makes it possible to some extent to predict and manipulate the mental states of others. In other words, knowing other's tendency to pick out the most relevant inputs and process them so as to maximize their relevance, the speaker may be able to produce a stimulus which is likely to attract their attention, activate an appropriate set of contextual assumptions and point them toward an intended conclusion.

The Applications of Relevance Theory

Yus (2006: 859-60) points out that relevance theory has been applied to a number of research areas, among which we can distinguish the following:

- 1- Grammar: the grammatical arrangement of utterances plays an important part throughout this cognitive contextualization. From this point of view, several aspects of grammar have been addressed, including connectives conditionals, modals and modality, adverbs and adverbials, mood(s), tense(s), the article, etc. (ibid.: 859)

The Cognitive Principle of Relevance and its Application.....(20)

- 2- Humour: within a relevance-theoretic approach, humour is no longer a property of texts and, instead, what we need to characterize are the audience's mental processes in the interpretation of humorous texts. Knowing that the addressee is likely to pick out the most relevant interpretation of the joke, the humourist may be able to produce a text that is likely to lead to the selection of an accessible interpretation, which is then invalidated at some point. (ibid.)
- 3- Literature: Several studies have applied relevance theory to literary discourse. Within a relevance theory approach, literary discourse has to be analysed as cognitive effects triggered by textual stimuli, involving special mental processes which, through a relevance-driven cognitive exploration, results in the marginally increased salience of a wide range assumptions. Because in literature it is more difficult (if not impossible) to make assumptions mutually manifest, a greater load of responsibility is laid upon reader in extracting the intended (or, alternatively, his/her own) interpretation of the texts, plus whatever feelings and emotions are associated with the comprehension of the text. (ibid.: 860)
- 4- Politeness: This is a typical social feature of communication that somehow appears not to suit the individual-centered approach within relevance theory. However, several studies have attempted an explanation of politeness in relevance-theoretic terms. For instance, politeness has been explained within relevance theory as a verbal strategy compatible or incompatible with the background expectations about the current relationship holding between the speaker and the hearer, thus leading to different relevance-oriented interpretative paths. (ibid.)
- 5- Translation: Many studies have applied relevance theory to translation exploiting the idea of resemblance between the intended interpretations of utterances. Thus relevance theory allows us to simplify the study of translation both by doing away with the need for a separate theory of translation and by allowing us, instead, to indistinctly apply the same concepts used in other types of language use to translation. Within the relevance-theoretic approach, research on translation has focused on two main areas: on the one hand, there has been an interest at the macro-level in characterizing translation as a communicative event involving interlinguistic resemblance between two texts or discourses, on the other hand, there has been an interest at the micro-level in understanding the cognitive and communicative

The Cognitive Principle of Relevance and its Application.....(21)

processes experienced by translators as receptors and communicators and the effect these processes have on the products of translation. (ibid.: 1100)

- 6- Media discourse: And this will be the primary interest of this study. Relevance theory has also been successfully applied to the interpretation of media discourses, including films, newspaper headlines, comics, internet discourses, and advertising and posters. The last type of media discourses may be one of the most extensive applications of the theory. The control over the amount of information provided, the predictability of audience's responses, and the calculation of the effort required to process information, all typical features of the strategies by the advertisement and poster makers, can easily be analysed using a relevance-theoretical approach. (ibid.: 860)

The model of Analysis

According to relevance theory, utterances raise expectations of relevance not because speakers are expected to follow Cooperative Principle and maxims or some other communicative convention, but because the search for relevance is a basic feature of human cognition, which communicators may exploit.

Relevance theory argues that the thing that causes an input to stand out from others is its relevance to the receiver. The contextual effects of an assumption in a given context are not the only factor to be taken into account in assessing its degree of relevance. Contextual effects are brought about by mental processes. Mental processes, like all biological processes, involve a certain effort, a certain expenditure of energy, the greater the processing effort, the lower the relevance. (Wilson & Sperber, 1995: 124)

Wilson and Sperber (1986: 252) make these rules:

- a. Other things being equal, the greater the positive cognitive effects achieved by processing an input, the greater the relevance of the input to the individual at that time
- b. Other things being equal, the greater the processing effort expended, the lower the relevance of the input to the individual at that time."

Cognitively speaking, what we have is a cost/benefit analysis whereby the cost of processing is weighed against the possible positive cognitive benefits. So the greater the effect of an utterance, the more relevant it is. Similarly, the effects needed to be economically achieved.

The Cognitive Principle of Relevance and its Application.....(22)

On these two rules, the present paper will depend on to be the model of the analysis. The posters selected for the purpose of the analysis contain themes, colours and portraits or figures of American soldiers participate in the American led war against Iraq. The moment the audience looks at these posters, they can infer the meaning of every single detail in them depending on their knowledge of the truth. The colours, the pictures, the drawings all signify a lot of meaning. The understanding of these meanings comes from the positive cognitive effects achieved by processing an input.

The Data

The data of this paper is (4) posters selected from the website (miniaturegigantic.com/gallery) which contains a gallery for anti-Iraq war posters done by people who are opponents to the US led war against Iraq.

The modal of the analysis will be the Sperber & Wilson principle of cognitive. What the hearer/reader/audience will do is searching for meaning in any given communication situation in the following posters and having found meaning that fits their expectation of relevance then the aims are fulfilled. The viewers of these posters will feel that utterances raise expectations of relevance because the search for relevance is a basic feature of human cognition which communicators may utilize.

1- First poster: Respect the eagle?



As well known, the Eagle is the symbol of the USA. After a long debate, congress chose the bald eagle to represent the United States in

The Cognitive Principle of Relevance and its Application.....(23)

1782. The eagle appears on the presidential seal, the seal of the United States and various American coins.

The eagle was chosen due to its strength and long life-span. The founders hoped to convey a sense of strength and power for the country. Furthermore, the eagle was also chosen because it was mistakenly believed to live exclusively in America.

It is so clear here that it could be said that everything implies something that is not said, since every utterance depends on association and background knowledge.

The poster shows the eagle bowing as he is killing a white dove which symbolizes peace with a blood spot beneath his leg. The audience relates and understands that the eagle feels ashamed of what he has done though he symbolizes strength and power of the country he represents.

The reason behind his sense of shame is the war against Iraq. The relevance here is so clear between the drawing and the implicit meaning. Moreover, the title of this poster is written by red colour which symbolizes evilness and killing as it represents blood and it is ironically said. The word (respect) means the opposite since killing innocents and invading others' countries don't lead to self-respect.

Besides, the title of the poster is written in an interrogative sentence. If it is said with a special high intonation, it gives the meaning of exclamation. It means shall we respect the eagle though he commits crimes against humanity and world peace represented by the white dove in the poster.

2- The second poster: They lose

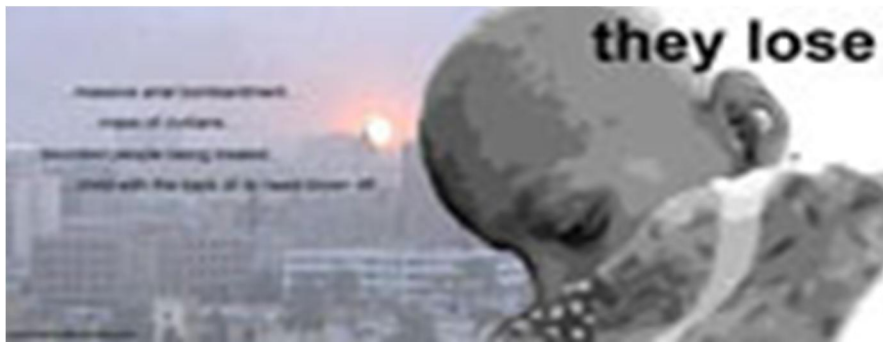

The audience needs no processing efforts to comprehend the relevant message in terms of compatibility with the communication abilities. As it is clear from the first glance, the soldier is bowing his head feeling

The Cognitive Principle of Relevance and its Application.....(24)

shameful of bombing Baghdad. The photo which appears in the background of the poster is so much used in reporting the first days of the war on Iraq in the media. Therefore, it is familiar to the audience. The relevance is that the intransitive verb 'lose' in (They lose) does not need a completion. This kind of verb serves the aim of not specifying the kind of loss. They, which mean Iraqis, lose what? They lose the battle and the USA wins it. It is said in an indeterminate way and also the soldier feels blushing of what they have done. The title of the poster is said ironically because, as it is clear from the way the soldier bowing his head, the audience feels that the soldier is defeated from inside though he wins the battle. The gray colour, as well, is very much representing his mood and his inner feelings of ashes remnant as a result of destruction and disintegration.

**3- The Third poster: Iraq is a graveyard for Americans.
THERE ARE BETTER WAYS TO LEAVE IRAQ.**



The endless line of soldier's boots, weapons and helmets left behind them as they are killed in Iraq means that they were killed by Iraqis. The expression (THERE ARE BETTER WAYS TO LEAVE IRAQ) means that they must have left Iraq alive walking and wearing their boots and helmets better than leaving their belongings in this un respectful and humiliating way. The capital letters used here to draw the attention to the importance of finding another ways to leave Iraq carried in boxes on shoulders.

Another thing one can recognize in this poster is the American flag hiding behind these boots and helmets as if it shies to appear in proud. It is shameful to put the flag higher than the boots, the poster designer put it behind these boots and one can hardly see it and its position does not draw the attention of the addresses. Further, these boots are not pairs.

The Cognitive Principle of Relevance and its Application.....(25)

This indicates the chaotic state of the dead soldiers and how their number is large to the extent that their belongings can not be arranged neatly. The gray colour also referred to their mood and to psychological disturbances they undergo as gray colour refers to sadness.

The cognitive processes in this poster most relevantly. Iraq becomes the graveyard for Americans because they have come to this country as invaders, and this is the inevitable end of invaders. If they had not come, they would have not killed in Iraq. The information provided and the predictability of the audience's responses can achieve a successful cognition of the message of this poster as if it is a conversation or no verbal interaction.

4- The Fourth poster: Contract Accomplished



Too many things can be inferred from this poster and can be interpreted depending on the relevance theory.

The water behind the soldier refers to the long distance between America and Iraq to get into Iraq. It is an overseas country. The Iraqi flag

The Cognitive Principle of Relevance and its Application.....(26)

without stars means that the Americans have emptied Iraq from its contents (oil, people). The machine is also painted with the Iraqi flag colours but the letters (R-Ak) in the middle shows that oil is now with them filling their petrol machines. The (CONTRACT ACCOMPLISHED), also written in capital letters for the same reason mentioned above, refers to the accomplishment of the war's aims and targets which can be summarized by controlling the oil fields in Iraq. The soldier's uniform appeared to be decorated with international and American oil company's slogans. This means that he is fighting on behalf of these companies and he has fulfilled the mission entrusted to him by pulling this oil pumping machine from overseas Iraq to his country. Pulling this machine, which refers to Iraq by means of the Iraqi map and flag painted on it, refers that Iraq entirely as a whole has been driven to the USA.

The soldier's face features (eyes, nose, mouth...etc) can not be recognized easily. He looks with aliens' features. This is quite good way of giving the impression of odd sort of job he has done with no clear limits, intentions, and justifications.

His facial expressions are hardly recognized, one can see sadness, misery, offense, embarrassment, and frustration as if he is disappointed with what has done.

The three divisions of the Iraqi map refer to the future plan of the USA to divide Iraq into three regions. Those who live in Iraq now can prove this assumption because all the premises of this plan are carried on in Iraq under different titles, sectarian fighting, outsider terrorists, etc.

The message is also accomplished with the audience and, cognitively speaking, the relevance of this poster is entirely obvious to be a symbol of opposing the war. It says that the war is actually for the sake of oil and other concealed political interests in the region and not for the sake of the other announced camouflaged aims.

Results and discussion:

By analyzing the data of this paper; the posters of anti-Iraq war, the processing of an input in the context of existing assumptions improve the

The Cognitive Principle of Relevance and its Application.....(27)

individual's knowledge not only by adding a new piece of information, but by revising his existing assumptions, or yielding conclusions not derivable from the new piece of knowledge alone or from existing assumptions alone. An input is relevant when and only when it has such positive cognitive effects. This positive cognitive reaches the audience exposed to these posters.

The results of the analysis show that the greater the positive cognitive effects achieved in an individual by processing an input at a given time, the greater the relevance of the input to that individual at that time. The smaller the processing effort expended by the individual in achieving those effects, the greater the relevance of the input to that individual at that time.

By applying the cost/benefit analysis, we find that the cost of processing the input derived from these posters weighed against the possible positive cognition benefit. The moment an audience looks at these posters, he/she can recognize the meanings indicated by the designers of these posters depending on their relevant knowledge about what happens during the war and the catastrophic consequences of this war on the American soldiers and people.

The posters contents, figures, and colours all talk to the audience and communicate the information with him/her. The moment the audience looks at these posters, he/she starts interpreting these contents and colours depending on their background information and on their familiarity with what has happened during this hateful war. The act of communication is only but the act of processing the cognition of the receivers with little efforts.

Conclusion

Relevance theory, developed by Daniel Sperber and Deirdre Wilson in 1986, is a psychological model for understanding the cognitive interpretation of language. The main assumption of the theory is that human beings are endowed with a biologically rooted ability to maximize the relevance of incoming stimuli including linguistic utterances and other communicative behaviour.

This theory seeks to explain the second method of communication: one that takes into account implicit inferences. It argues that the hearer/reader/audience will search for meaning in any given communication situation and having found meaning that fits their expectation of relevance will stop processing.

This theory can be applied in different fields. Media discourses such as advertisements and posters are among those field. Information implied in the poster can be inferred immediately by means of finding the relevance of this information with the content of the posters.

The results of analyzing anti-Iraq war posters as the data of this paper show the applicability of the cognitive principle of the relevance theory on these posters by achieving successful communication and cognition processes. It is considered sufficient to achieve conversation or other verbal and non-verbal interaction.

ملخص البحث

تعتبر نظرية التاربط بالموضوع التي اطلقها دان سبيربر و درايدر ولسون عام ١٩٨٦ واعدوا نشرها عام ١٩٩٥ ، نموذج نفسي للتفسير الادراكي للغة. تنص هذه النظرية على ان الذي يجعل بعض المدخلات ذات الارتباط دوناً عن الاخرى هي كونها مدخلات ذات صلة بالنسبة للمتلقي وان كل جملة تخلق لدى المتلقي توقعات ذات صلة بمعلوماته السابقة. والفرضية المهمة لهذه النظرية هي انه في اي سياق معين، يفترض المتلقي ان يكون الكلام ذا صلة لديه. يتناول هذا البحث تطبيق هذه النظرية على ملصقات جدارية (بوستر) رسمها اناس معارضون للحرب التي تقودها الولايات المتحدة ضد العراق. وقد تم تطبيق هذه النظرية في تحليل محتويات هذه الملصقات لمعرفة كيف تحقق التواصل بنجاح بين الجمهور ومكونات هذه الملصقات التي لها صلة بمعارضة الحرب ضد العراق.

References

- Cutting, Joan. (2008). Pragmatics and Discourse: A resource book for students. 2ed. London: Routledge.

The Cognitive Principle of Relevance and its Application.....(29)

- Crystal, David (2003). English as a global language. 2ed ed. Cambridge: Cambridge University Press.
- Lenk, U. (1998). Marking Discourse Coherence: Functions of Discourse Markers in Spoken English. Tübingen: Gunter Narr Verlag.
- May, J. Jacob. (1993). Pragmatics: An Introduction. Oxford: Blackwell Publishers.
- Okada, Moeko (2001). Linguistic Approaches to the Analysis of Humour in Modern English Dramatic Comedy. Unpublished Thesis Submitted for the Degree of Doctor of Philosophy to the Department of Linguistics and Modern English Language, University of Lancaster
- Sperber, Dan & Deirdre Wilson (1986) Relevance: Communication and Cognition. Oxford: Blackwell Publishers Ltd.
- ----- (1995): Relevance: Communication and Cognition, Second Edition, Oxford: Blackwell Publishers Ltd.
- -----(2002) Truthfulness and Relevance. Author(s): Reviewed work(s): Source: Mind, New Series, Vol. 111, No. 443 (Jul., 2002), pp. 583-632 Published by: Oxford University Press on behalf of the Mind Association Stable
- URL: <http://www.jstor.org/stable/3093623>.
- Retrieved on : 27/3/2014
- Verschueren, Jef. (1999). Understanding Pragmatics. London: Oxford University Press.
- Wilson, Deirdre and Sperber, Dan (2006) Relevance Theory, In: The Handbook of Pragmatics. L. R. Horn and G. Ward(eds.), Oxford : Blackwell Publishing Ltd.
- Weaver, Warren. The Mathematical Theory of Communication. September, 1949
- http://waste.informatik.huberlin.de/Lehre/ss11/SE_Kybernetik/reader/weaver.pdf
- retrieved on 15.3.2014
- Yus, Francisco (2006). Relevance Theory. In: Concise Encyclopedia of Pragmatics. Ed. J.L. Mey. Amsterdam: Elsevier, 854-861.
- Anti-Iraq war posters gallery
- <http://www.miniaturegigantic.com/gallery1.html#>

The Cognitive Principle of Relevance and its Application.....(30)

- Retrieved on : 2/3/2013
- <http://www.dan.sperber.fr/?p=93>
- Retrieved on : 1/3/2014
- (http://www.ehow.com/facts_6880038_eagle-symbol-america_.html)
Why eagle is chosen to represent the USA.
- Retrieved on : 2/3/2014