



ELSEVIER

Contents lists available at ScienceDirect

MethodsX

journal homepage: [www.elsevier.com/locate/mex](http://www.elsevier.com/locate/mex)



Method Article

# Measuring the vertical profile of leaf wetness in a forest canopy



Binks Oliver<sup>a,\*</sup>, Carle Hannah<sup>a</sup>, Coughlin Ingrid<sup>a</sup>, da Costa Antonio Lola<sup>b</sup>, Meir Patrick<sup>a,c</sup>

<sup>a</sup> Research School of Biology, The Australian National University, Canberra 2601 ACT, Australia

<sup>b</sup> Centro de Geosciências, Universidade Federal do Pará, Belém 66075-110, Brazil

<sup>c</sup> School of Geosciences, University of Edinburgh, EH9 3FF, United Kingdom

## ABSTRACT

Plant canopies are wet for substantial amounts of time and this influences physiological performance and fluxes of energy, carbon and water at the ecosystem level. Leaf wetness sensors enable us to quantify the duration of leaf wetness and spatially map this to canopy structure. However, manually analysing leaf wetness data from plot-level experiments can be time-consuming, and requires a degree of subjective judgement in delineating wetness events which can lead to inconsistencies in the analysis. Here we:

- Describe how to set up an array of leaf wetness sensors (Phytos 31, Meter) enabling the measurement of leaf wetness duration through the profile of a forest canopy,
- Present a method and R script to objectively identify and distinguish periods of rain and dew from the output of leaf wetness sensors,
- Provide a criteria for separating the leaf wetness sensor output into dew and rain events which may form a reference standard, or be modified for use, in future studies.

© 2021 The Authors. Published by Elsevier B.V.

This is an open access article under the CC BY-NC-ND license (<http://creativecommons.org/licenses/by-nc-nd/4.0/>)

## ARTICLE INFO

*Method name:* Measuring canopy wetness

*Keywords:* Leaf wetness, Forest canopy, Forest water balance, Micrometeorology

*Article history:* Received 20 January 2021; Accepted 26 March 2021; Available online 2 April 2021

DOI of original article: [10.1016/j.agrformet.2020.108250](https://doi.org/10.1016/j.agrformet.2020.108250)

\* Corresponding author.

E-mail address: [oliver.binks@anu.edu.au](mailto:oliver.binks@anu.edu.au) (B. Oliver).

<https://doi.org/10.1016/j.mex.2021.101332>

2215-0161/© 2021 The Authors. Published by Elsevier B.V. This is an open access article under the CC BY-NC-ND license (<http://creativecommons.org/licenses/by-nc-nd/4.0/>)

## Specifications Table

Subject Area	Environmental Science
More specific subject area	Forest ecology
Method name	Measuring canopy wetness
Name and reference of original method	Aparecido, L.M.T., Miller, G.R., Cahill, A.T. and Moore, G.W., 2016. Comparison of tree transpiration under wet and dry canopy conditions in a Costa Rican premontane tropical forest. <i>Hydrological Processes</i> , 30(26): 5000-5011.
Resource availability	If applicable, include links to resources necessary to reproduce the method (e.g. data, software, hardware, reagent)



**Fig. 1.** Picture of a leaf wetness sensor 'rig'. The panel on the left shows the attachment of the supporting rope to the scaffold pole which is mounted on the meteorological tower. The panel on the right shows a view looking upwards including the tower and the rig.



**Fig. 2.** Leaf wetness sensor connected to angled bracket and rope.

## Setting up leaf wetness sensors

### Overview

The extent and duration of plant canopy wetness influences physiological performance and ecosystem level fluxes of energy, carbon and water. Leaf wetness sensors enable us to quantify the duration and spatial distribution of leaf wetness [1], but manually analysing leaf wetness data is impractical and relies on subjective judgements that can lead to inconsistency. Here we present the methods for: (i) setting up leaf wetness sensors (Phytos 31, Meter, Pullman, USA) in a forest canopy profile; and (ii) a method and R script for objectively distinguishing between rain and dew events (see co-publication [2], Agr.For.Met.). The Supplementary Information includes an R script for detecting rain and dew events in leaf wetness sensor data (SI 1), and the program used for the data logger and multiplexer (SI 2); and the leaf wetness data on which this study was based (Caxiuana National park, Brazil, an Eastern Amazonia field site), has been uploaded to Mendeley Data (<http://dx.doi.org/10.17632/sbrbbn7skn.1>).

We used Phytos 31 (originally Decagon LWS) leaf wetness sensors because the dielectric method of detecting surface wetness is more accurate, responsive and reliable over the long term than the alternative method of measuring a change in electrical resistance used in sensors such as Campbell Scientific 237, Davis Leaf Wetness Sensor Vantage Pro2, and the Pessl Instruments LWS [3]. Moreover, the Phytos 31 is 'designed to approximate the thermodynamic properties of most leaves' in terms of its specific heat capacity, size and shape, and does not require additional coats of latex paint which can deteriorate over time. However, the protocol for positioning the sensors below may also be applied to other sensors types. The script for interpreting the data may also form a template for the interpretation of any sensor with a continuous analogue output, but will require changes to the threshold values.

Two 'rigs' were set up either side of a micrometeorological tower in the Brazilian Amazon (Fig. 1). Each rig consisted of a single rope to which nine leaf wetness sensors (henceforth referred to as 'sensors') were attached, and was constructed on the ground before being hoisted into position onto the tower. Such a rig could also be installed in the upper canopy of a tall/emergent tree. In order to keep the length of cable to a minimum, thereby reducing both the weight and cost of the rig, all sensors on a single rig were connected to a common power and ground cable, but had independent excitation (data) cables. We wanted to capture the transition of wetness conditions through the densest part of the upper canopy, and therefore we positioned sensors more closely together at the

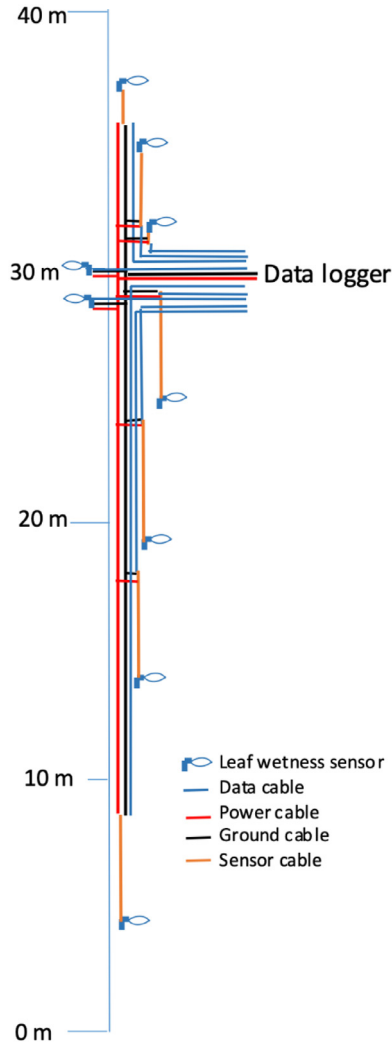
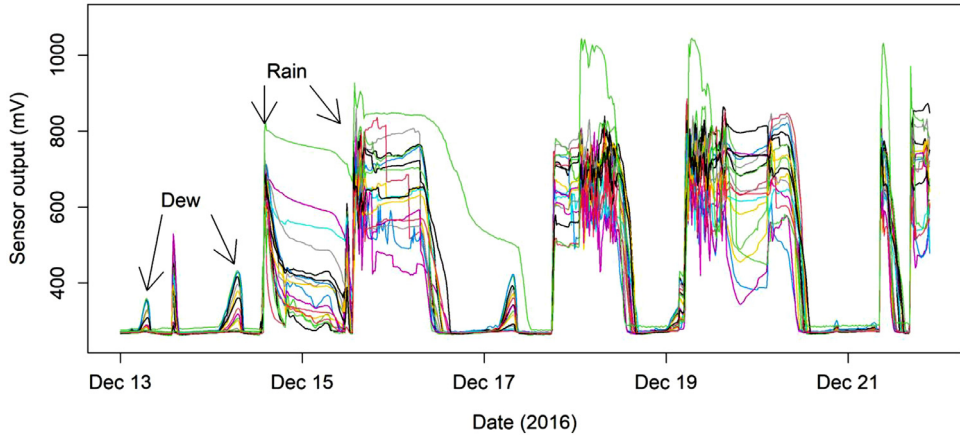

**Fig. 3.** A wiring schematic for the leaf wetness rigs. Note the common power and ground cables, but independent data cables. Description of connections provided in text.

top of the rig than bottom. Sensor pairs (one sensor per rig) were located at heights of 4, 14, 19, 24, 28, 30, 32, 34, and 36 m from the ground, where the height of the top of the canopy was around 30 m with emergent trees attaining heights of 55 m (see [2] for canopy profile). Sensors were cleaned approximately every three months.

#### *Assembling the leaf wetness rigs*

Each sensor was fastened to a 90° 75 mm metal bracket using two cable ties, one around the sensor body and one around the cable. Note: the brackets could be bent to an alternative angle in order to more closely represent leaves. The brackets were then attached to 10 mm thick nylon rope at the relevant locations using small cable ties, with at least one cable tie being passed through the



**Fig. 4.** Example of raw data output from 17 leaf wetness sensors (Meter). Note the gradual signal increase in response to dew, in contrast to the sudden change in output in response to a rain event.

rope in order to prevent slippage of the sensor bracket (Fig. 2). A loop was tied in the end of each rope for fastening to the tower, and sensor positions were marked on each rope with respect to the loop, i.e., distance from the top. A data logger (CR1000, Campbell Scientific, Utah, US) was situated at a height of 28 m in the tower, between the upper and lower most sensors, in order to minimize total cable length. Thus, the cables of the sensors were arranged along the ropes towards the position of the data logger.

### Wiring

The power and ground terminals of the lowest and highest sensors on each rig were connected to either end of the common power and ground cables (rating: 7.5 A) using sleeve connectors, and waterproof heat shrink (Fig. 3). All of the intermediate sensors were connected to the common power and ground cables using splice connectors, and were waterproofed using silicon sealant. The excitation (data) terminals from all of the sensors were independently wired to the data logger and so were extended by connecting additional cable using sleeve connectors and waterproof heat shrink. Finally, cables for connecting the common power and ground lines to the logger, were connected to the common lines using splice connectors and sealed with silicon sealant. Thus, a single rig, with nine sensors, had a single power and ground cable, and nine excitation cables for connection to the logger when *in situ*. All cables were then securely taped and cable-tied to the ropes such that there was no force/weight placed on any of the cable connections.

### Position

A scaffold pole was positioned horizontally at the top of the meteorological tower, which extended at least 1.5 m beyond each side of the tower to minimise the influence of the tower. The ends of the rigs, at the bottom of the tower, were pulled into position and looped over the scaffold pole at a distance of 1.5 m from the tower and thus were positioned within the adjacent forest canopy. The lower end of the ropes were fastened to a stake in the ground to prevent the rigs from swinging.

### Logger

All 18 sensors were logged from a single CR1000 data logger connected to an AM16/32B multiplexer (Campbell Scientific), and programmed to log the output every 15 min. The logger ground

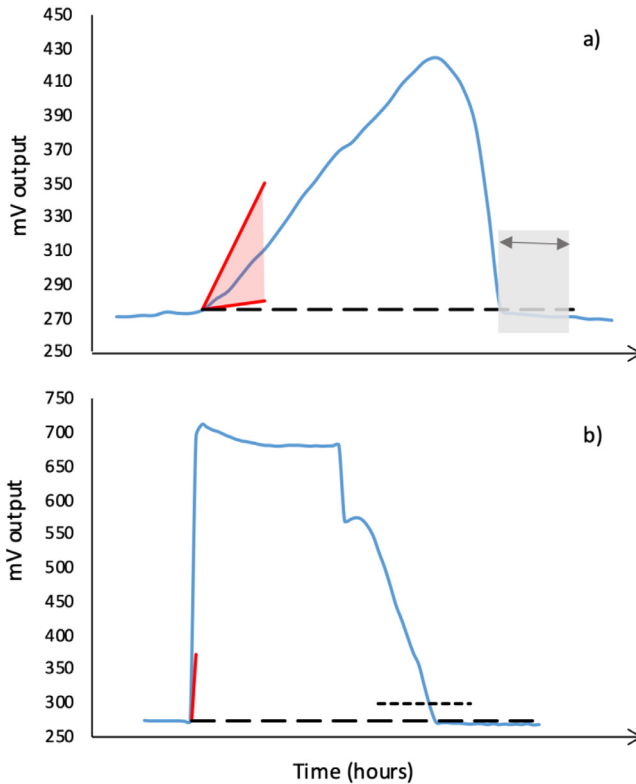

**Fig. 5.** Identification criteria for a dew (a) and rain (b) event where the blue line is the output of a leaf wetness sensor. **For dew** (a): the starting condition is when the gradient is  $0.07\text{--}1.00\text{ mV min}^{-1}$  for 1.25 h, here represented by the area shaded red; the starting time is the first time point when the subsequent 1.25 h meets the starting condition, and is designated as the threshold for this event (dashed line); the ending condition is when the average of the absolute difference of five successive time points (1.25 h) is less than  $0.5\text{ mV}$  and the sensor value is less than the threshold value: the area shaded in grey. **For rain** (b): the starting condition was taken to be a change in sensor output of over  $100\text{ mV}$  in a single  $15\text{ min}$  time step ( $> 6.67\text{ mV min}^{-1}$ ), which equates to a gradient steeper than the red line; the starting time is the first time point when the subsequent change in values meets the starting condition, and is designated as the threshold for this event (long dashed line). Each subsequent time step was designated as 'rain' until the sensor value dropped below  $110\%$  of the threshold value (short dashed line) (For interpretation of the references to color in this figure legend, the reader is referred to the web version of this article.)

was connected to the tower which was connected to a ground rod. The program for the data logger and multiplexer are available as SI.

#### Analysis of leaf wetness data

Due to the large quantity of data, we developed a script that objectively identified each time period as either 'dry', 'rain' or 'dew'. While the magnitude of the output from the leaf wetness sensors (millivolts) does not represent the level of saturation, the rate at which the signal increases can be used to distinguish between rain- or dew-related wetness (Fig. 4., co-publication [2]). Furthermore, over time the baseline value of a sensor (i.e., the sensor value when dry) can drift due to a build-up of detritus on the sensor, or possibly even a change of electrical resistance at the cable connections. Our script resolves this issue by using a moving ('floating') threshold for the baseline value.

Data were initially cleaned, which involved removing data that were obviously faulty (with respect to the other sensor outputs) and values that were out of the range specified by the manufacturer.

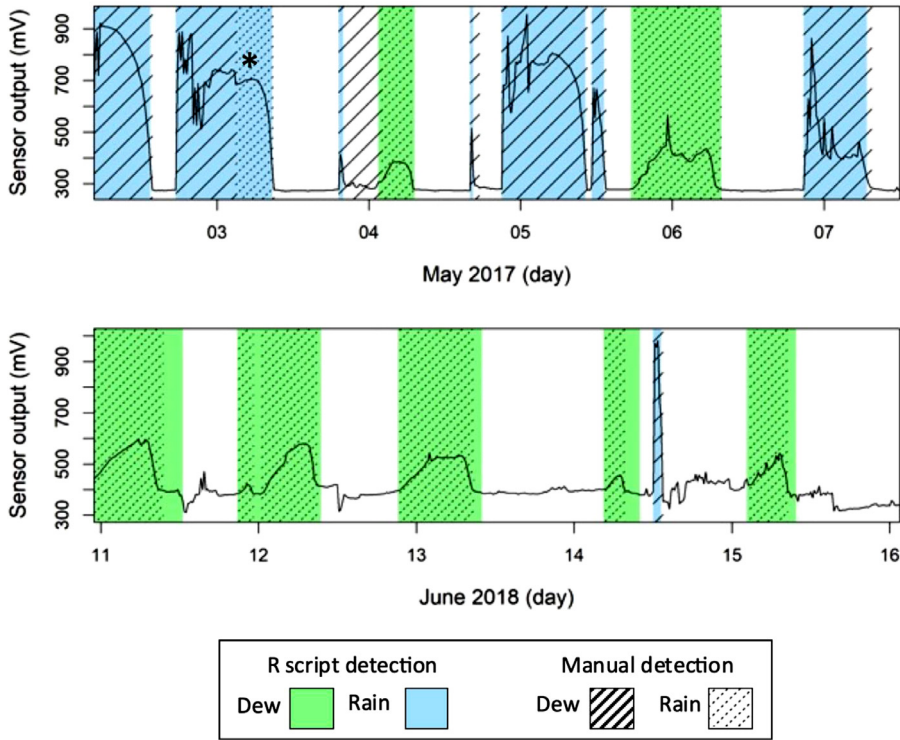

**Fig. 6.** Example of the manual validation of the wetness detection script from a single leaf wetness sensor in two randomly chosen five day periods. The black line is the raw output of the sensor, while the blue and green shading respectively show rain and dew events as detected automatically by the *R* script. Rain and dew events that were identified manually are designated by solid and dotted hatching respectively. The code detection method matches that of manual detection where: solid hatching coincides with blue shading, dotted hatching coincides with the green shading, and non-hatched areas coincide with non-shaded areas. The asterisk in the top panel indicates a co-occurring dew event which the detection script failed to identify. The detection script had an accuracy of 89 % in the top panel, 91 % in the lower panel, and overall accuracy of 90.0 %  $\pm$  0.1 % standard deviation when including all validation data (For interpretation of the references to color in this figure legend, the reader is referred to the web version of this article.).

### Identifying dew

The start of a dew event was defined as the first time step in a series of five time steps (where one time step is 15 min) in which the change in output signal ( $\Delta x$ ) was 1–15 mV for all five time steps ( $1 < [x_{i+1} - x_i] < 15$ ) (Fig. 5). That is, the slope of the sensor output was 0.07–1.00 mV min<sup>-1</sup> for at least 1.25 h. The sensor value at the start of the dew event was then taken to be the floating threshold. The dew event was considered to have ended when the absolute mean of the difference between five time steps was  $< 0.5$  (i.e.,  $-0.5 < [x_{i+1} - x_i] < 0.5$ ) for 1.25 h, and the value of the sensor is  $\leq$  threshold value (i.e., at signal level lower or equal to that before the dew event).

### Identifying rain

The start of a rain event was identified based on a change in sensor output of  $> 100$  mV in one time step. The sensor value at the start of the rain event was then taken to be the floating threshold. Each subsequent time step was designated ‘rain’ until the sensor value decreased to below 110% of the threshold value.

### Identifying co-occurring dew events

Dew often occurred following rain events, when the sensors were still wet from rain. Such events are referred to as 'co-occurring' dew events. Consequently the analysis was conducted twice, once including co-occurring dew events and once without, Analyses A and B, respectively in Binks et al. (co-publication 2020). The difference in the analysis is a result of prioritising one event over another. For example, to detect co-occurring dew events, the dew detection script was run first, then the rain detection script was run with the criteria of a rain event only occurring when there was not already dew. To omit co-occurring dew events, the rain detections script was run first, then dew detection script was run with the criteria of a dew event only occurring when there was not already rain-related wetness.

Rain and dew were detected from the data using independent loops in R [4], thus Analysis A first identified the dew events and then only designated a time step 'rain', if it was not already identified as 'dew', while Analysis B had the opposite priority (rain, then dew).

### Method validation

Five randomly selected periods of five days were chosen to test the detection script. Data from each of the functioning sensors in a given time period was manually inspected and each time point was designated as either 'rain', 'dew' or 'dry' (Fig 6). The number of time points which matched between the manual detection and code detection script was divided by the total number of time points giving the proportion of correctly identified wetness events. In total, this amounted to 62 sensor periods that were validated against manually inspected data. The mean proportion of time periods correctly identified using the code detection method was 0.90 +/- 0.10 standard deviation, the median was 0.91, and values ranged from 0.65 to 1.00.

### Uncited reference

.

### Declaration of Competing Interest

The authors declare that they have no known competing financial interests or personal relationships that could have appeared to influence the work reported in this paper.

### Funding

This work was supported by: ARC grant DP17010409 to PM; UK NERC grants NE/J011002/1 and NE/N006852/1 to PM; CNPQ grant 457914/2013-0/MCTI/CNPq/FNDCT/LBA/ESECAFLOR to ACLD; EU FP7-Amazalert grant to PM.

### Supplementary materials

Supplementary material associated with this article can be found, in the online version, at doi:[10.1016/j.mex.2021.101332](https://doi.org/10.1016/j.mex.2021.101332).

### References

- [1] L.M.T. Aparecido, G.R. Miller, A.T. Cahill, G.W. Moore, Comparison of tree transpiration under wet and dry canopy conditions in a Costa Rican premontane tropical forest, *Hydrol. Process.* 30 (26) (2016) 5000–5011.
- [2] O. Binks, et al., Canopy wetness in the Eastern Amazon, *Agric. For. Meteorol.* (2020) 108250.
- [3] A. Ghobakhlou, F. Amir, P. Sallis, Leaf wetness sensors - a comparative analysis, in: *Proceedings of the 9th International Conference on Sensing Technology (ICST)*, 2015, pp. 420–424.
- [4] R Development Core Team: *A language and Environment for Statistical Computing*, R Foundation for Statistical Computing, 2010.