

Improvement of wheat cultivation technology with Increased yield and product quality

*Vladimir Milyutkin*¹, *Yri Kirov*¹, *Dmitry Rudoy*^{2,3*}, *Anastasiya Olshevskaya*², *Mary Odabashyan*², *Aleksey Prutskov*², *Anna Vershinina*², *Dzhuletta Sarkisian*²

¹Samara State Agrarian University, 2, Uchebnaya St., Ust-Kinelskiy, 446409, Russia

²Don State Technical University, 1, Gagarin Sq., Rostov-on-Don, 344003, Russia

³Agricultural Research Center "Donskoy" FSBSI, Nauchny Gorodok Str. 3, Zernograd, 347740, Russian Federation

Abstract: The article is devoted into the study of the optimisation of the process of using liquid nitrogen mineral fertilisers based on a carbamide-ammonia mixture, both in the serial form of CAM-32 and in the innovative CAM+S (with the addition of the sulfur mesoelement (S)) as a top dressing for winter wheat in spring during tillering. The application process was carried out superficially on crops with large-drop nozzles with a serial rod sprayer "Tuman-2" and an injection-innovative multi-injector unit "Tuman-2M". The article presents the improvement of the technology of cultivation of winter wheat of the "Basis" variety with the use of liquid mineral nitrogen and nitrogen-sulfur-containing fertilisers. The results obtained will improve the technology of wheat cultivation and improve the quality of the crop. The results of the research are an increase in yield compared with the use of granular solid mineral fertilisers: ammonium nitrate with the same nitrogen equivalent from 16.7 to 2.64 t/ha or from 34.5 to 58.1% and an improvement in grain quality to the level of class I compared with class III wheat quality when it is cultivated using innovative technologies described in this work.

1 Introduction

To increase crop yields, a well-planned program to increase soil fertility is necessary. It is necessary to use a special well-planned program to increase soil fertility.

Such programs require foresight and planning. One of the most useful tools that farmers can use when planning soil fertility is fertilisation, fertilisation rates, placement and timing [1].

There are some useful tools that farmers can use when planning soil fertility such as fertilisation, fertilisation rates, placement and timing [1].

* Corresponding author: rudoy.d@gs.donstu.ru

It is important to feed wheat with nitrogen, calcium, phosphorus, sulfur, potassium and magnesium. And Also, it is necessary to do this at different stages of plant development. In the first three months (during germination and emergence of shoots), it is important to apply nitrogen, potassium and phosphate fertilisers.

An important role in this area is given to increasing the grain harvest of spring soft wheat: one of the main sources of nutrition. Under favourable conditions, the yield of this crop in the fields of experimental farms can reach 2.7–3.3 t/ha, and with an increase in productivity to 1.5 t/ha, the state can harvest up to 20-23 million tons of grain annually. The average wheat yield in 2022 in the country was 3.43 t/ha against 2.65 t/ha a year ago (2021).

Rational use of agrotechnical techniques, mineral fertilisers and plant protection contribute to obtaining the desired harvest with high grain quality [2]. Technological approaches such as fertilisers based on CAM with complex application improve the biological properties of grain.

Researchers from the University of Chinese Academy of Sciences conducted a three-year study to investigate the one-time introduction of nitrogen into the root zone to increase wheat yield and nitrogen use at different distances between rows of crops in the Yangtze River Delta region in China [3]. The authors found that the one-time introduction of nitrogen into the root zone (ORZ) increased the yield of wheat compared to the traditional separation of nitrogen N by translation (CSB). Wheat sown in straight rows had a higher yield than wide and narrow rows under ORZ [3].

The FAO's current forecast for grain production in the world in 2021 has been increased by 2.2 million tons, and it currently stands at 2,796 million tons, which is 0.7 percent higher than last year. The forecast of wheat production in the world this month has not changed and amounts to 775.4 million tons, reflecting an increase in gross production in Australia, which ensures the preservation of record production levels, despite a slight downward revision of forecasts for the EU, Iraq and Paraguay [4].

At the moment, there is a growing need to increase the rate of agricultural production, especially from plant-growing raw materials, taking into account the negative projected global warming and recurring critical droughts in many regions [3-5]. To solve this problem and increase production, it is necessary to further improve crop cultivation technologies through the wider use of innovative technical and technological products [6-8], in particular the use of nitrogen fertilisers [7] in liquid form [8-10] based on a carbamide-ammonia mixture - CAM in pure form – CAM-32 (N-32%) and with the addition of a mesoelement – sulfur - CAM + S (N-26%, S-2.5-4.0%).

Carbamide-ammonia mixture (CAM) is a mixture of aqueous solutions of ammonium nitrate and carbamide. This is the only nitrogen fertiliser, which includes all three forms of nitrogen, so that the action of CAM is prolonged and plants are supplied with nitrogen for longer.

This is the only nitrogen that contains all three forms of nitrogen, so that the action of CAM is prolonged and plants are supplied with nitrogen for longer.

The mixture contains 50% amide form of nitrogen, 25% ammonium, 25% saltpeter. CAM-28, CAM-30, CAM-32 are produced, in which the proportion of nitrogen is 28, 30, 32%, respectively [11].

In the works of researchers from Peoples' Friendship University of Russia (RUDN University), it was found that with an increase in the intensity of cultivation of winter wheat varieties, grain quality and yield increased by 3.8 t/ha.

Previously, the researchers from Peoples' Friendship University of Russia (RUDN University) found out

This was observed in all studied varieties. The results showed that when creating a production system by a normative method, varietal characteristics, plant nutrition conditions,

agrochemical characteristics of the soil and meteorological factors should be taken into account [12].

In the works of researchers from the Key Laboratory of Plant Nutrition and Agro-environment in Northwest China, it was revealed that the dose of fertiliser depends on the amount of precipitation. The researchers provide formulas for calculating the exact application of fertilisers based on the annual amount of precipitation falling on wheat, or precipitation for the summer season [13].

CAM is a unique, innovative, highly effective liquid nitrogen fertiliser with a prolonged effect due to the versatile action of three forms of nitrogen on plants: nitrate-8%, ammonium-8% and amide-8%, and only the amide form can be absorbed by the vegetative part of crops [15,16]. In the following years after field application, the residual effect of previous fertilisers will contribute to the total available nitrogen [15]. The same long-term effect is absent when applying synthetic urea fertilisers [16].

However, wheat yield is affected not only by fertiliser, but also by cultivation and breeding methods. In the studies of researchers from the Institute of Crop Sciences, Chinese Academy of Agricultural Sciences and Field Crops Research Institute, Agricultural Research Center, it was found that the use of new improved varieties, new cultivation techniques, modern irrigation methods contributed to an increase in yield per unit area by 97%, and an increase in yield by 1.5% occurred due to the expansion of sowing area squares. Therefore, the increase in total yield mainly depended on the increase in yield per unit area. Wheat production in Egypt has improved due to the development of breeding and cultivation methods. The use of these new methods, the popularisation of new varieties of high-quality seeds and the use of the raised beds method instead of the old method of planting in pools have made the greatest contribution to increasing yields [17].

Simple single-operation machines are replaced during technical re-equipment with more complex, combined, universal, multifunctional, more efficient aggregates with digital control of the technological process [10]. An example of such an approach is the innovative technologies of highly efficient production of agricultural crops in the Samara Region studied by the Samara State Agrarian University, mainly on the basis of regional technical and technological means using liquid and solid nitrogen-sulfur-containing mineral fertilisers of one of the leading chemical concerns in Russia - PJSC KuibyshevAzot (Moscow Togliatti, Samara region) and self-propelled, universal, multifunctional machines for fertilisers and plant protection products – “Tuman...” of LLC Pegas-Agro (Samara) (Fig.1).

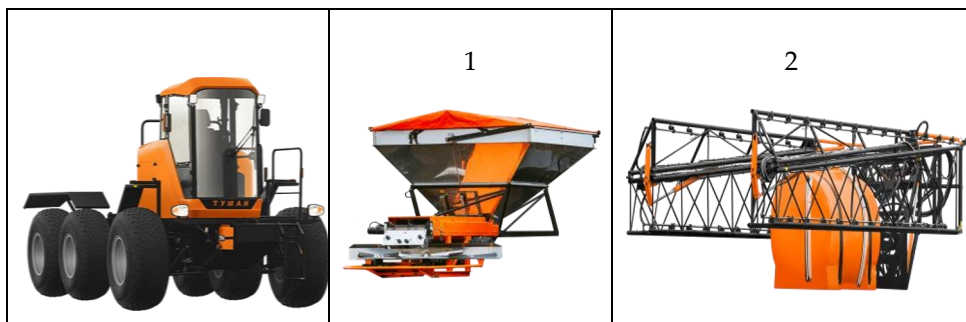

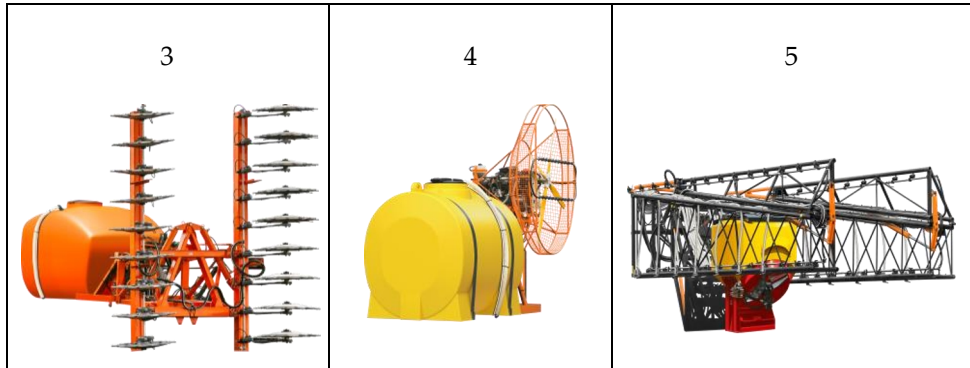

Fig.1. Integrated multi-operational self-propelled complex “Tuman...”

The multifunctional complex “Tuman” of LLC Pegas-Agro with a full set of technological equipment provides basic agrochemical work in field production and combines 5 modules on one transport and energy base (Fig. 1): 1 - a spreader of solid mineral fertilisers, 2 - a rod sprayer for chemical plant protection products-pesticides, and for the application of liquid mineral fertilisers, 3 – innovative unit for the application of liquid mineral fertilisers-multi-injector, liquiliser 4 - fan sprayer, 5 - module for sowing small-seeded crops. The innovation of the integral complex “Tuman” consists in its multi-operability due to the possibility of replacing working technological modules within 3-5 hours, depending on the type and purpose of the work.

The aim of the study is a systematic justification of ways to improve winter wheat technology through the use of innovative liquid nitrogen-sulfur-containing mineral fertilisers based on a carbamide–ammonia mixture - in pure CAM-32 (N-32%) and with a meso-element: sulfure CAM+S (N-26%, S-2.5%) PJSC KuibyshevAzot (Russian Federation, Samara region) with the use of various methods of surface and injection of their application by a special multifunctional modular unit “Tuman...” produced in Russia by LLC Pegas-Agro (Samara). At the same time, data are especially in demand for the selection by agricultural producers of optimal methods and norms of CAM application, depending on weather conditions and moisture availability of crops.

2 Materials and methods

The research was carried out on the experimental fields of the university on plots with an area of 1200m² in three-fold repetition. Agrotechnical and operation-al-technological studies were carried out in 2021-2022 on winter wheat on an innovative multi-injector unit (liquiliser) “Tuman-2M” when applying liquid classic fertilisers CAM-32 and innovative CAM+S (Fig. 1.3), the results of the study were also compared with the rod sprayer “Tuman-2” (Fig.1.2), both with single and fractional fertilisation.

Before sowing in autumn, spring and during harvesting of winter wheat, the presence of nitrogen, phosphorus, potassium and sulfur in the soil was determined. The amount of nitrogen in the leaves was determined by the “N-tester” device. Portable device N-Tester for plants is a sensor for determining the nitrogen content and the amount of chlorophyll in the leaves. The total nitrogen content was determined by the Tyurin microchrome method. Mobile compounds of phosphorus and potassium were determined by the Machigin method in the modification of CINA0. The mobile sulfur was determined by the CINA0 method.

When cultivating wheat, mechanised tillage was carried out. Soil preparation before sowing winter wheat of the “Basis” variety was carried out with a KUPE-4PV cultivator.

Winter wheat seeds were sown to a depth of 5-6 cm, row spacing of 15 cm using a “Klyon” seeder.

Harvesting was carried out for 12 days after the full ripening of the grains using a combine harvester (self-propelled grain harvester RSM-101 “Vector-410”).

Fertilisation in the experiments was calculated by soil fertility and moisture capacity to achieve maximum yield, taking into account the varietal capabilities of winter wheat “Basis”. The study investigated the optimal mineral nutrition of winter wheat of the “Basis” variety with nitrogen fertilizers, the “Tuman” machine in solid form: ammonium nitrate (N-32%) “Tuman-2” (Fig.2a) and in liquid form, CAM-32 (N-32%) and CAM+S (N-26%, S-2,2-4,0) introduced by the sprayer “Tuman-2” (Fig.2b) and the multi-injector “Fog-2” (Fig.2b).

On April 30, 2021, three norms of CAM+S fertiliser were introduced into the tillering phase during treatment with a multi-injector (Fig.2, c): 200, 300 and 350 l/ha; when treating crops with a sprayer (Fig.2, b), on April 28, 2021, CAM+S was introduced with a norm of 200 l/ha in pure form and with potassium humate at the rate of 5 l/ha and copper (copper sulphate CuSO_4) - 0.5 kg / ha. Ammonium nitrate – N-33% (NPK 33,0,0) was used as fertiliser on the control sample. Manufacturer: Nov-Agro (Russia). Fertiliser for the control sample was applied at the rate of 300 kg ha.



a)



b)



c)

Fig.2. Equipment of LLC Pegas-Agro: a) - spreader of solid mineral fertilizers; b) - rod sprayer; c) - multi-injector

The research in 2021 was conducted on soft winter wheat of the “Basis” variety, sown on August 26, 2020 in the fields of the Samara State Agrarian University. The “Basis” variety is included in the State Register for the Middle Volga region and is recommended for the Samara region, the Republic of Tatarstan, and the Ulyanovsk re-gion. A variety is erythrosperrum. The bush is intermediate. The plant is of medium length - long. The wax coating on the upper internode is medium, in the middle of the flag leaf is medium - strong, on the ear weak - medium. The ear is cylindrical, of me-dium length, medium density is dense, white. Awns of medium length. The lower spikelet scales on the inner side have a weak - medium pubescence. The shoulder is rounded - straight, of medium width. The tooth is moderately curved, of medium length. Pubescence of the apical segment of the ear axis from the convex side is medi-um - strong. The grain is colored. The weight of 1000 grains is 38-46 g. The average yield in the region is 4 t ha .3 t/ha.

The average early variety - the growing season is 297-328 days. Winter hardiness is above average - increased. The height of the plants is 78-106 cm. It is resistant to lodging. Baking qualities at the level of a good filler. It is susceptible to brown rust. In the field, powdery mildew and snow mold are weakly affected.

Soil samples were analysed for fertility indicators: nitrogen (N), phosphorus (P), potassium (K). With a further increase in fertiliser application rates (200, 300, 350 l/ha), the nitrogen content in the soil increases with a positive effect on increasing yield and quality. That is, the use of liquid CAM +S, where the main chemical element is ni-trogen (N), provides an increase in nitrogen in the soil in proportion to the rate of ap-plication of CAS + S (Table 1), (Fig.3). At the same time, the treatment of winter wheat crops with a multi-injector is more effective with the sprayer at the same application rates (200 l/ha).

The physical and chemical analysis of grain was determined by standard methods: Protein was determined by the Kjeldahl method, humidity was determined by drying in a drying cabinet at fixed parameters: temperature (130 °C), drying time (40 min) and calculating humidity as a percentage by changing its mass by drying the sample before and after drying, the quantity and quality of raw gluten it was determined in accordance with the methodology presented in ISO 21415-2-2019 mechanically using a system for determining the quantity and quality of gluten Gluten Washer 2100, glassi-ness was determined according to the standard procedure based on the results of the inspection of the grain section.

In further observations during the growing season of winter wheat for the effec-tiveness of CAM introduced by various technologies, observations were made of the condition of winter wheat crops of the “Basis” variety treated with CAM+S mul-ti-injector and sprayer (treatment on April 28-30, 2021), while the best efficiency of processing winter wheat crops was provided by a multi-injector when the plant height was - 60-70 when treating crops with a sprayer with the same rate of application of CAM+S, the height of the plants was less - 40-50 cm (10-20 cm less). We also assessed the condition of the leaf part of winter wheat with the N-tester device according to the nitrogen-N content (Table 2), which showed its increase after CAS treatments.

According to meteorological data for two years, of which 2021 was a dry year, since, during the growing season of winter wheat – August 2020 - August 2021, pre-cipitation fell 435.7 mm against 575.8 mm - average data, and 2022 was more favour-able in terms of moisture, precipitation for the same period fell 580.4 mm, which is 144.7 mm more. Although the weather in 2020 and 2021 before sowing for winter crops in the Samara region was not favourable enough: there was a low degree of soil moisture, which is in principle natural for the Volga region (Samara region), due to late precipitation and warm weather, winter seedlings and tillering were good, the overwintering was satisfactory and the crops looked good in spring. As a result, in ac-cordance with weather conditions, when the average amount of precipitation during the growing season of winter wheat in 2021 (13 months - from August 1, 2020 to Au-gust 31, 2021) fell by 24% less than the average annual figures in 2022 - 435.7

mm ver-sus 580.4 mm (13 months - from August 1, 2021 year to August 31, 2022), respectively, and the average yield of winter wheat in the Samara region as a whole in 2021 was low-about 2.0 t/ha than in 2022- by 1.72 t/ha and was equal to 3.72 t/ha. Weather conditions of the current season 2021-2022 were favorable for winter wheat, which is con-firmed by the receipt of a record harvest of winter wheat in the Samara region – 4.42 t/ ha. t ha t ha ... t ha.t ha.

3 Results

The results of the study on the analysis of the average yield of winter wheat vari-ety “Basis” according to the variants of experiments compared with the control – 3.99 t/ha shows:

According to the results of the study and analysis of the experiments that were held on the winter wheat variety “Basis” compared with the control – 3.99 t/ha it can be resumed:

1. When processing winter wheat of the “Basis” variety in the tillering phase with a sprayer “Tuman-2” with the use of liquid nitrogen-sulfur-containing fertilisers CAM significantly increases the yield of wheat. When processing crops with CAM with a sulfur-S norm of 200 l/ha, the yield increased to 4.84 t/ha (increased by 21.1%), at the same rate of 200 l/ha, but with the addition of organic fertiliser potassium humate - 5 l/ha and trace element copper (Cu) in the amount of 0.5 kg/ha yield increased to 6.28 t/ha (increased by 57.4%) compared to the control;

2. When processing winter wheat of the “Basis” variety in the tillering phase with the innovative multi-injector unit “Tuman-2M” with liquid nitrogen-sulfur-containing fertilisers, the yield increases significantly to a greater extent compared with the treatment of crops with a sprayer. Thus, when processing crops with CAM with sul-fur-S with a rate of 200 l/ha with a multi-injector, the yield increased to 5.61 t/ha (in-creased by 40.5%), at a rate of 300 l/ha, the yield increased to 5.2 t/ha (increased by 45.7%), at a rate of 350 l/ha, the yield increased to 7.5 t/ha or (increased by 79.1%) compared to the control (Table 1). When studying the nitrogen content, it can be con-cluded that the largest amount of nitrogen in comparison with the control values was found in the sample Sprayer, Multi-injector, CAM+S - 350 l/ha nitrogen content was 31.26. The lowest result was obtained with Sprayer, CAM+S: 200 l/ha, humates 5 l/ha + Copper 0.5 kg/ha, nitrogen content was 19.3.

In our experiments, when processing winter wheat crops with a multi-injector at a rate of application of 200 l/ha, the yield was obtained almost equal (within 5% of the experimental error from the control), but with large rates of CAM application, the multi-injector showed greater efficiency compared to the sprayer. That is, with a fur-ther increase in fertilizer application rates (300, 350 l/ha), the nitrogen content in the soil increases with a positive effect on increasing yield and quality.

Table 1. Nitrogen content (nitrogen Md, %) in the soil when winter wheat is treated with liquid mineral fertilisers CAM+S sprayer (200 l/ha), CAM+S (200l/ha) + Humates (5 l/ha) + Copper (CuSO₄ - 0.5 kg/ha), and multi-injector (200, 300, 350 l/ha)

Technical means of application			
Sprayer		Sprayer	
Sprayer, CAM+ S-200 l/ha	Sprayer, CAM+ S-200 l/ha	Sprayer, CAM+ S-200 l/ha	Sprayer, CAM+ S-200 l/ha
19.3	19.3	19.3	19.3

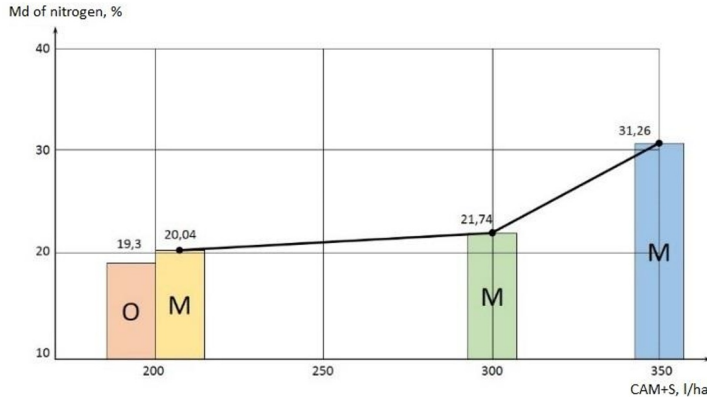

Fig.3. Dynamics of changes in nitrogen content (nitrogen Md,%) in the soil during the treatment of winter wheat crops with liquid mineral fertilisers CAM+S sprayer (O) - 200 l/ha and multi-injector (M) - 200, 300, 350 l/ha

- especially with a rate of application of 350 and 200+200l/ha.

Table 2. The presence of nitrogen-N in the leaves of winter wheat according to the variants of the experiment (May 24, 2021)

Sprayer Tuman-2M (Pegas-Agro)	Multi-injector Tuman-2M (Pegas-Agro)			
CAM+S - 200 l/ha	CAM+S - 200 l/ha	CAM+S - 300 l/ha	CAM+S - 350 l/ha	CAM+S - 200 l/ha + multi-injector - CAM+S: 200 l/ha
736	735	740	750	760

Indicator “amount of nitrogen – N” in leaves significantly (more than 5% of the error of experience) increases, especially with an increase in the rate of application of CAM +S, in particular without liquid fertilisers CAM + S, this indicator was 722 units, which is 13-14 units less than when processing wheat with a sprayer and a multi-injector with a rate of 200 l/ha and 18-38 units less than when treatment of plants with a multi-injector norm of 300-350 l/ha.

In general, the use of liquid nitrogen-sulfur-containing fertilisers CAM+S provided high yields (Fig. 5) and grain quality (Table 4). At the same time, CAM+S with a norm of 200 l/ha in a tank mixture with potassium humate (5 l/ha) and a trace element-copper-copper sulfate-CuSO₄ (0.5 kg/ha) with a rod sprayer treatment increases yields by almost 30% compared to with pure CAM+S (Fig. 4).

When studying the nitrogen content in leaves after fertilisation by various methods, it was found that the highest content is obtained with Sprayer “Tuman-2” (“Pegas-Agro”) - CAM+S: 200 l/ha + multi-injector - CAM+S: 200 l/ha (760), the smallest – with Multi-injector “Tuman-2M” (“Pegas-Agro”) - CAM+S 200 l/ha.

The indicator “amount of nitrogen-N” in leaves on winter wheat without liquid fertilisers CAM+S was 722 units, which is 4% less than when processing wheat with a multi-injector “Tuman” (“Pegas-Agro”) norm of 350 l/ha. In general, the use of liquid nitrogen-sulfur-containing fertilisers of CAM provided high yields (Table 3,) and grain quality (Table 4).

CWhen processing crops in-soil with the introduction of CAM+S with a rate of 200 l/ha with a multi-injector compared to a sprayer, the yield increased from 48.4 to 56.1 c/ha or by

15%. With an increase in the CAM+S application rate from 200 to 350 l/ha, the yield of winter wheat increases from 56.1 to 71.55 c/ha, or by 27.5%, which is significant. As an experiment, taking into account that CAM has 3 forms of nitrogen, from which amide nitrogen is absorbed by leaves, in experiments winter wheat in the tillering phase was treated with CAM+S sprayer with a norm of 200 l/ha and a multi-injector with a norm of 200 l/ha with a yield of 63.8 c/ha - at the level of wheat treatment with a sprayer with potassium humate and copper (Fig.4), (Table 3).

Table 3. The yield (t ha c/ha) of winter wheat is the “Basis” variety in the experiments of the Samara State Agrarian University in 2020-2021 from CAM+S produced by PJSC KuibyshevAzot using various technologies of application by the equipment of LLC Pegas-Agro: sprayer (leaf feeding) and multi-injector (intra-soil application)

No.	Variants of application technology	Yield, t ha	Increase in yield, % of control
1	Without fertilisers, control	3.99	-
2	Sprayer, leaf dressing in the tillering phase-CAM+S-200 l/ha	4.84	21.2
3	Sprayer, leaf dressing in the tillering phase-CAZ+S – 200 l/ha, potassium humate - 5 l/ha, copper(CuSO ₄) - 0.5 kg/ha	6.28	57.4
4	Multi-injector, application in the tillering phase - CAM+S-200 l/ha	5.61	40.5
5	Multi-injector, application in the tillering phase - CAM+S - 300 l/ha	5.82	45.7
6	Multi-injector, application in the tillering phase - CAM+S - 350 l/ha	7.15	79.1
7	Sprayer, leaf dressing - CAM+S – 200 l/ha + multi-injector, application in the tillering phase - CAM+S - 200 l/ha	6.38	59.7

The introduction of CAM increases the protein and gluten content in the grain. The use of CAM on winter wheat shows a significant improvement in grain quality (Table 4). When CAM+S is applied with a sprayer in the tillering phase, it provides an increase in protein - the main baking quality for flour - compared with the control (mass fraction - 13.3%) to 16.3-16.6% mass fraction (growth is 22.5-24.8%), multi-injector compared with the control to 15.3-16.7% mass fraction, or by 15.5-25.6% of the control. Practically the same effect was obtained from the use of CAM in terms of grain quality – gluten (Table 4). Thus, the use of CAM on winter wheat with the introduction of a sprayer according to the standards adopted in the experiments in the tillering phase also provides an increase in the basic baking quality for flour - gluten compared with the control (mass fraction - 25.7%) to 30.3-31.4% mass fraction - (an increase of 17.9-22.0%) from the control, multi-injector compared to with control up to 29.6-31.2%, the mass fraction (an increase of 15.1-21.4%) of the control.

Table 4. The quality of winter wheat grain is the “Basis” variety, depending on the application technologies of CAM (CAM+S) at different application rates and tank mixtures (+copper-CuSO₄ + potassium humate): sprayer with large-drop sprayers (O) and multi-injector (M) “Tuman” (2021)

Indications	Control	(O) KAC+S , 200 l/ha	(O) KAC+S 200 l/ha, Cu 0,5 kg/ha, potassium humate 5 l/ha	(M) KAC+S 200 l/ha	(M) KAC+S 300 l/ha	(M) KAC+S 350 l/ha
Md protein, %; class	13.3; III cl.	16.6; I cl.	16.3; I cl.	15.3; I cl.	16.3; I cl.	16.7; I cl.
Md gluten, %; class	25.7; III cl.	31.4; II cl.	30.3; II cl.	29.6; II cl.	30.9; II cl.	31.2; II cl.
IDK, unit; group	58.0; I gr.	56.8; I gr.	56.5; I gr.	55.1; I gr.	56.8; I gr.	54.2; I gr.

Vitreous, %; class	39.6; III-IV cl.	40.4 III-IV cl.	39.6; III-IV cl.	37.5; III-IV cl.	39.6; III-IV cl.	38.6; III-IV cl.
-----------------------	------------------------	-----------------------	---------------------	------------------------	---------------------	---------------------

In studies on changes in the quality of winter wheat grain, crops without their treatment with liquid nitrogen-sulfur-containing mineral fertilisers CAM+S were taken for the “control” and the protein in this version of the experiments was the lowest - 13.3%

When processing crops with fertilisers CAM both in pure form and tank with a mixture with the addition of potassium humate and copper, a sprayer manufactured by the LLC, the quality parameters for protein were practically the same: 16.6-16.3%, but significantly superior to the “control” by 24.8-22.5%. The in-soil application of CAM+S by an innovative multi-injector unit at a rate of application from 200 to 350 l/ha significantly affects the protein content in the grain. Thus, when applying liquid fertilisers CAM +S at a rate of 200 l/ha, protein increased by 2% compared to the control (Md), which is at the same time 15%; at a rate of 300 l/ha, protein increased by 3%, which corresponds to 22.5% of the “control”; with a fertiliser application rate of 350 l/ha, protein increased by 3.4%, which corresponds to 25.6% of the “control”, which significantly improved the grain quality indicator and allowed it to be classified as quality class I with quality class III in the “control” - without fertilisers.

In studies of the quality of winter wheat grain without the use of liquid nitrogen-sulfur-containing fertilisers CAM +S gluten was 25.7% (MD). When treated with fertilisers CAM+S gluten was 31.4% (MD), when processing crops with a tank mixture with potassium humate and copper gluten was 30.3% (MD).

CAM+S multi-injector standards from 200 to 350 liters/ha increased the gluten content in the grain. Thus, when applying liquid fertilisers CAM+S at a rate of 200 l/ha, gluten increased by 4% compared to the control (Md), which at the same time amounted to 15.1% of the “control”.

At the fertiliser application rate of 300 l/ha, gluten increased by 5.2%, which corresponds to 20.2% of the “control”; at the application rate of 350 l/ha, gluten increased by 3.4%, which corresponds to 21.4% of the “control”, that is, grain is classified as quality class II at class III of the control.

Thus, the application of CAM+S both by a sprayer on the leaf part of plants and by a multi-injector intra-soil, made it possible to improve the quality of winter wheat grain of the “Basis” variety in 2021: wheat protein increases class c III to I, gluten - from III to II.

.t ha .t ha .t ha .t ha Studies in favourable weather conditions in 2022 to assess the effectiveness of the innovative multi-injector unit “Tuman-2M” in comparison with the rod sprayer “Tuman-2” when applying nitrogen liquid fertilisers CAM+S with trace elements showed an increase in the yield of winter wheat relative to the control from 5.17 to 7.85 t ha c/ha (Fig.5) with an increase in yield up to 52%.

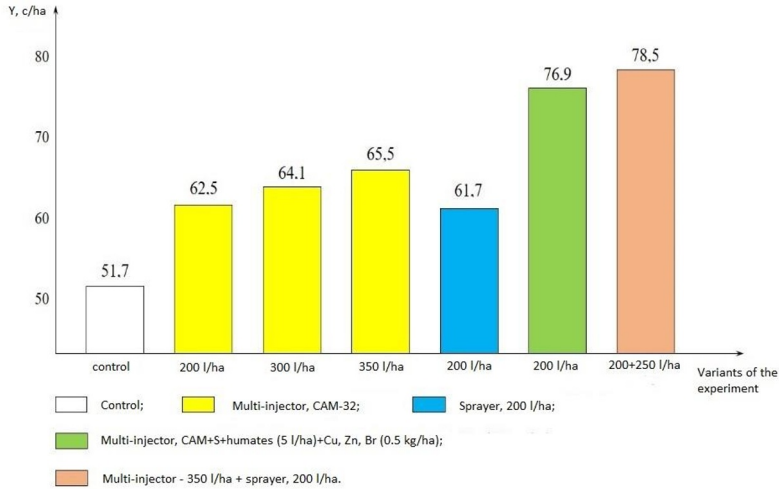

Fig. 5. Yield (t ha c/ha) of winter wheat “Basis” when using liquid mineral fertilisers CAM+S with the equipment of LLC “Pegas-Agro”: superficially in the tillering phase with a sprayer (O), intra-soil by multi-injector (M) and together (O+M) compared with the control-without fertilisers (experiments in 2022)

When studying the effect of nitrogen liquid mineral fertilisers CAM+S on the quality of winter wheat grain of the “Basis” variety in the year of 2022, which was favourable by humidification (Table.5) in comparison with the dry year 2021 (Table.4) a similar trend of grain quality improvement was obtained.

Table 5. Quality indicators of winter wheat (% , (I-IV-class) in experiments with different nutrition and technologies of application of CAM +S units “Tuman-2” - sprayer (O), “Tuman-2M”-multi-injector (M) in experiments of the Samara State Agrarian University in 2022.

Variants of experiments	Protein, %, (class)	Humidity,%	Quality of gluten,unit of IDK device,%, (class)	Quality of gluten,unit of IDK device,%, (class)	Glassiness, %, (class)
1. Control, ammonium nitrate	11.579(IV)	12.615	19.867(IV)	67.470(I)	44.919(II)
2. (O)CAM+S-200 l/ha	11.659 (IV)	12.796	20.422(III)	68.023(I)	45.479(II)
3.(M) CAM+S-200 l/ha	12.797(III)	12.442	22.551(II)	69.072(I)	47.085(II)
4.(M)CAM+S-300 l/ha	14.318(I)	12.396	25.163(II)	63.225 (I)	43.459(II)
5.(M)CAM+S-350 l/ha	14.269(I)	12.816	25.407(II)	67.243(I)	46.566(II)
6.CAM+S (O)-200 l/ha (M)-250 l/ha	13.828(I)	12.600	24.798(II)	65.444(I)	44.836(II)
7. CAM+S-200 l/ha + potassium humate -5 l/ha; + Cu + Zn + Br -0.5 kg/ha +	19.780(I)	12.620	24.452(II)	67.039(I)	44.060(II)

inhibitor - 0.1 kg/ha					
--------------------------	--	--	--	--	--

The assessment of the quality of winter wheat grain “Basis” was carried out according to the main milling indicators: protein and gluten. The use of CAM+S with a rate of application of 200-450 l/ha with a sprayer and a multi-injector and with tiered treatment together with a multi-injector and a sprayer. Thus, when applying ammonium nitrate (control) and treating CAM+S crops with a sprayer and a multi-injector with a norm of 200 l/ha protein (1-3 variants, Table.5), the protein was 11.579, 11.659% (IV class) and 12.797% (III class), in all other experiments (4-7 variants, Table.5) with an increase in the rate of application of CAM+S to 300, 350 and 450 l/ha, when treated with a multi-injector and sprayer together, the class of wheat in protein, protein improves to I cl.

Gluten is also used in 1-2 variants of experiments (Table.5) the mass fraction of gluten is 19.86% (class IV) and 20.42% (class III), and with an increase in the rate of application of CAM +S more than 200l /ha, the mass fraction of gluten increases to a maximum of 25.407% and in all variants of experiments this indicator improves to class II quality. According to the quality of raw gluten (unit of the IDK device, in all experiments, a grain of class I was obtained. The results obtained are of great importance for obtaining winter wheat grains with high baking qualities, especially in a wet year with high yields.

In general, when winter wheat was fertilised with liquid fertilisers CAM+S in the tillering phase with a multi-injector, the yield compared to the control increased from 51.7 to 6.55 t ha c/ha (Fig.5) - or by 26.7%, when potassium humate-5L/ha and trace elements – Cu, Zn, Br 0.5 kg/ha wheat yield increased to 7.69 t ha c/ha or 48.7%. The effectiveness of the introduction of CAM tank mixtures using meso- and micro-fertilisers was also studied.

Fertilisers were applied intra-soil with a multi-injector, and superficially with a sprayer, almost double the rate of 250+200 l/ ha CAM + S to determine the maximum possibilities of the effect of CAM on increasing the yield of winter wheat. At the same time, the highest yield was obtained – 7.85 t ha c/ha, which is 51.8% higher than the control, significantly exceeding the record high average yield of winter wheat in the Samara region – 4.4.2 t ha c/ha on 424 thousand hectares by the end of 2022 with favorable weather for many years in terms of humidity compared with a lower average yield for Samara region - 20 kg/ha of winter wheat in a dry and unfavourable for agriculture, but typical for the region in 2021.

Since 2022, “Pegas-Agro” LLC (Samara, Russia) has started production of self-propelled technological complexes “Tuman” on a new base platform with improved technological indicators and appearance for all agrochemical works at a new modern production site – at a new plant (Fig.6).



Fig. 6. Technological self-propelled complexes “Tuman” from “Pegas-Agro” LLC (Samara, Russia): a) - rod sprayer, b) - spreader-distributor of solid mineral fertilisers

4 Discussion

The global growth of the Earth's population is about 75 million, or 1.1% per year. The need for food in the world is steadily growing against the background of global population growth. The food problem is not just a lack of food. The process of its production, long before it reaches grocery stores, causes many problems affecting the duration and quality of life on earth.

It is necessary to increase the rate of growing spring wheat, improve the quality of the crop and contribute to improving soil fertility [20,26]. At the same time, it is recommended to apply a fertiliser based on CAM before sowing wheat and in the tillering phase. For optimal application and avoiding burns when spraying fertiliser, apply intra-soil with the help of a multi-injector "Tuman-2", as it is designed for point injections of liquid fertilisers.

During the pre-sowing application of CAM and processing of grain crops in the tillering phase, it is allowed to work with concentrated solutions under favourable weather conditions. When surface processing of grain in the phase of the stem elongation, it is necessary to use not concentrated CAM, but its solutions.

The maximum possible effect from the use of liquid fertilisers was obtained with the combined application of CAM + S of almost double the norm (with a multi-injector intra-soil + a surface sprayer). At the same time, the yield was 7.85 t/ha, or 51.8% higher relative to the control values.

According to the results of our long-term research, nitrogen liquid fertilisers based on urea-ammonia mixture CAM significantly affect the increase in yield and quality of cultivated crops.

When using CAM, the most effective technology for its application, especially in dry years, is intra-soil injection by a multi-injector. In our experiments, the "Tuman-2M" multi-injector produced in Russia by LLC Pegas-Agro showed good results.

In general, liquid mineral fertilisers of CAM have an advantage over solid fertilizers, especially in dry years, which is especially important in the conditions of predicted global warming.

5 Conclusions

The results of our study revealed that wheat productivity increases when fertilising with a multi-injector intra-soil. The most optimal results were obtained when using nitrogen-sulfur-containing mineral fertilisers based on a carbamide-ammonia mixture of CAM with the addition of a mesoelement - sulfur S (CAM + S).

The introduction of liquid mineral nitrogen-sulfur-containing fertilisers CAM+S on winter wheat of the "Basis" variety, despite unfavourable dry-hot conditions, provided a sufficiently high yield of wheat – up to 7.0 t/ha, and in a more favourable humidification year 2022, the maximum yield in experiments reached 7.85 t/ha. The use of this method of fertilisation leads to positive results. With an increase in yield, the main baking indicators for the mass fraction of protein and gluten by class also significantly increase.

The innovative technology of CAM application applicable to winter wheat has provided improvements in protein quality class I compared to class III, and gluten – quality class II compared to Class III.

The condition of the crops was good, the grain quality according to baking indicators, mainly gluten and protein, was also high for winter wheat and was at the level of III–II classes, which indicates the effective action of nitrogen liquid mineral fertilisers. The effectiveness of innovative technologies with the introduction of liquid nitrogen mineral fertilisers CAM will be greater with the use of precision agriculture and additional agrotechnical measures for moisture accumulation and its economical use [27,30].

Author Contributions: Conceptualization, Vladimir Milyutkin and Besarion Meskhi; methodology, Yri Kirov; software, Anna Vershinina; validation, Dmitry Rudoy, Anastasiya Olshevskaya, Mary Odabashyan; formal analysis, Dzhuletta Sarkisian; investigation, Aleksey Prutskov; resources, Natalya Kulikova; data curation, Anastasiya Olshevskaya; writing—original draft preparation, Yri Kirov; writing—review and editing, Vladimir Milyutkin visualization, Anna Vershinina; supervision, Dmitry Rudoy; project administration, Anastasiya Olshevskaya; funding acquisition, Aleksey Prutskov. All authors have read and agreed to the published version of the manuscript.

Institutional Review Board Statement: Not applicable.

Data Availability Statement: All data obtained or analysed in the course of this study are included in this published article (and its additional information files)

Conflicts of Interest: The authors declare no conflict of interest.

References

1. Malcolm J. Hawkesford. Reducing the reliance on nitrogen fertilizer for wheat production, *Journal of Cereal Science*, Volume 59, Issue 3, 2014, Pages 276-283, <https://doi.org/10.1016/j.jcs.2013.12.001>.
2. Rebouh, Nazih & Polityko, Petr & Kapranov, Vladimir & Fedorischev, Viktor & Garmasch, Nina & Atmachian, Gaik. (2020). Impact of cultivation technologies on yield and grain quality of winter wheat *Triticum aestivum* L. in Moscow region. *RUDN Journal of Agronomy and Animal Industries*. 15. 113-122. 10.22363/2312-797X-2020-15-2-113-12.
3. Hang Song, Weiwei Huan, Guoyin Yuan, Dianjun Lu, Xiaoqin Chen, Huoyan Wang. One-time root-zone nitrogen application increased wheat yield and nitrogen utilization under distinct planting row spacings in the Yangtze River Delta Region of China, *Field Crops Research*, Volume 295, 2023, 108900, <https://doi.org/10.1016/j.fcr.2023.108900>.
4. Official website <https://www.fao.org/>
5. Agriculture in Russia. 2021: Stat.sat./Rosstat –From 29 M., 2021. – 100 p.
6. Yudina E.M. Improvement of technical means for processing row spacing / E.M. Yudina, N.V. Malashikhin // *Izvestiya Orenburg State Agrarian University*. – 2019. – № 3(77). – Pp. 131-133.
7. William Wilson, Sumadhur Shakya, Bruce Dahl. Dynamic changes in spatial competition for the nitrogen fertilizer industry in the United States. *Agricultural Systems*. Volume 135, May 2015, pp 10-19.
8. Zavalin A.A., Chernova L.S., Sapozhnikov S.N., Kovalenko A.A. Consumption of soil nitrogen by plants under the application of a mineral fertilizer, green manure, and biopreparation (the study involves 15n) *Russian Agricultural Sciences*. 2020. V. 46. № 1. pp 39-42.
9. Zavalin A.A., Alferov A.A., Plyushchikov V.G., Tchernova L.S., Slobodyanyuk K.V. Nitrogen flows and sustain-ability of agrosystem. *International Journal of Engineering and Advanced Technology*. 2019. V.9. №1. pp.4961-4966.
10. L. Myuller, V.G. Sychev, V. Romanenkov and others, Innovation and knowledge transfer for sustainable landscapes, V: New methods of landscape research in Europe, Central Asia and Siberia. Monograph in 5 volumes. V.G. Sychev, L. Myuller (corr.) pp 25-42 (Moscow, 2018).
11. Yu.F. Lachuga, I.V. Savchenko, P.A. Chekmarev et al., Water-accumulating technologies, soil treatment techniques and the use of mineral fertilizers in extreme

- conditions (Ryazan, 2014). R.A. Bulavintsev, Analysis of the design of openers of modern seeders for direct seeding of agricultural crops, *Agrotechnics and energy supply*, 2 (19), 85-91 (2018).
12. Rebouh NY, Polityko PM, Kapranov VN, Fedorischev VN, Garmasch NJ, Atmachian GP. Impact of cultivation technologies on yield and grain quality of winter wheat *Triticum aestivum* L. in Moscow region. *RUDN Journal of Agronomy and Animal Industries*. 2020; 15(2): 113—122. doi: 10.22363/2312-797X-2020-15-2-113-122.
 13. Xhiyuan Gao, Hanbing Cao, Ming Huang, Ming Bao, Weihong Qiu, Jinshan Liu. Winter wheat yield and soil critical phosphorus value response to yearly rainfall and P fertilization on the Loess Plateau of China, *Field Crops Research*, Volume 296, 2023, 108921, <https://doi.org/10.1016/j.fcr.2023.108921>.
 14. V.A. Sidorova, E.E. Zhukovskii, P.V. Lekomtsev, V.V. Yakushev, Geostatistical analysis of the soil and crop parameters in a field experiment on precision agriculture, *Eurasian Soil Science*, 45(8), 783-792 (2012).
 15. D. Kurtener, V. Yakushev, E. Krueger, H.A. Torbert, Zoning of an agricultural field using a fuzzy indicator model, In the collection: *Precision Agriculture 2011 - Papers Presented at the 8th ECPA 2011*, 8, 157-163 (2011).
 16. V.A. Milyutkin, V.N. Sysoev, A.P. Trots, I.N. Guzhin, S.N. Zhiltsov, Technical and technological operations for the adaptation of agriculture to global warming conditions, *BIO Web of Conferences*, 17, 00075 (2020).
 17. Braun, H.J., G. Atlin, and T. Payne. 2010. In: Reynolds, CRP. (ed.). *Climate change and crop production*, CABI, London, UK. FAOSTAT. 2012. [online] available at <http://faostat.fao.org>. Heff er, P. 2009. International Fertilizer Industry Association. Paris, France IFADATA, 2012.[online]available at <http://www.fertilizer/homepage/statistics>. Rosegrant, M.W. and M. Agcaoili. 2010. International Food Policy Research Institute, Washington, D.C., USA.
 18. Kishk Abdelmageed, Xu-hong CHANG, De-mei WANG, Yan-jie WANG, Yu-shuang YANG, Guang-cai ZHAO, Zhi-qiang TAO, Evolution of varieties and development of production technology in Egypt wheat: A review, *Journal of Integrative Agriculture*, Volume 18, Issue 3, 2019, Pages 483-495, [https://doi.org/10.1016/S2095-3119\(18\)62053-2](https://doi.org/10.1016/S2095-3119(18)62053-2).
 19. Tan, Y., Chai, Q., Li, G. et al. Improving wheat grain yield via promotion of water and nitrogen utilization in arid areas. *Sci Rep* 11, 13821 (2021). <https://doi.org/10.1038/s41598-021-92894-6>.
 20. Buxmann, V., Meskhi, B., Mozgovoy, A., Rudoy, D., Olshevskaya, A.: Innovative technologies and equipment from „Amazone" company for fertilizer application, ITESE-2020. E3S Web Conf. 210, 04002 (2020). DOI: 10.1051/e3sconf/202021004002.
 21. Milyutkin V., Sysoev V., Blinova O., Makushin A., Prazdnichkova N. Improvements in corn production technology using liquid nitrogen fertilizers In the collection of scientific papers: *BIO Web of Conferences. Agriculture and Food Security: Technology, Innovation, Markets, Human Resources*. Kazan, 2021. P. 00122.
 22. Milyutkin V.A., Sysoev V.N., Makushin A.N., Dluzhevskiy N.G., Bogomazov S.V. Advantages of liquid mineral fertilizers on the base of KAS-32 in comparison with solid fertilizers (ammonium nitrate) on sunflower and corn Volga Region Farmland. 2020. №3 (7). P. 55-60.
 23. Milyutkin V., Buxmann V., Mozgovoy A., Rudoy D., Olshevskaya A. Modern Technology for Cultivation of Agricultural Crops in Zones of “Risk Farming” with

- Conservation and Accumulation of Atmospheric Moisture. Lecture Notes in Networks and Systems book series (LNNS), volume 246, pp 138-146 (2022). doi: 10.1007/978-3-030-81619-3-15.
24. Meskhi B., Bondarenko V., Efremenko I., Larionov V., Rudoy D., Olshevskaya A. Technical, technological and managerial solutions in ensuring environmental safety. IOP Conference Series: Materials Science and Engineering, Volume 1001, 012100. International Scientific and Practical Conference Environmental Risks and Safety in Mechanical Engineering(ERSME-2020) doi:10.1088/1757-899X/1001/1/012100
 25. Milyutkin V.A., Miliutkin A., Mozgovoy A., Maltseva T., Chigvintsev V. Innovative technologies for the efficient use of uan liquid fertilizers: production, logistics and application in case of lack of moisture and global warming/В сборнике: Networked Control Systems for Connected and Automated Vehicles. Proceedings of the International Conference. Zlin, 2023. С. 1375-1383.
 26. Lazarev V.I., Minchenko Zh.N. Efficiency of new forms of liquid nitrogen fertilizers on winter wheat crops in the conditions of the Kursk region. In the collection: Rational land use: optimization of agriculture and crop production. Collection of reports of the V International Scientific and Practical Conference dedicated to the 80th anniversary of the birth of Academician A.P. Shcherbakov. Kursk Federal Agrarian Scientific Center. 2021. pp. 155-160.
 27. Lazarev V.I., Minchenko Zh.N., Bashkatov A.Ya., Trutaeva N.N. The effectiveness of foliar fertilizing with humic preparations of spring wheat in the soil and climatic conditions of the Kursk region. Agrochemistry. 2022. No. 8. pp. 51-58.
 28. Bhogal A. Williams J.R., Nicholson F.A., Chadwick D.R., Chambers K.H., Chambers B.J. (2016) Mineralization of organic nitrogen from farm manure applications. Soil Use Manag 32:32–43. <https://doi.org/10.1111/sum.12263>.
 29. Gutser R., Ebertseder T., Weber A., Schraml M., Schmidhalter U. (2005) Short-term and residual availability of nitrogen after long-term application of organic fertilizers on arable land. J Plant Nutr Soil Sci 168:439–446. <https://doi.org/10.1002/jpln.200520510>.
 30. Schröder J.J., Jansen A.G., Hilhorst G.J. (2006) Long-term nitrogen supply from cattle slurry. Soil Use Manag 21:196–204. <https://doi.org/10.1111/j.1475-2743.2005.tb00125.x>
 31. Paul J.W., Beauchamp E.G. (1993) Nitrogen availability for corn in soils amended with urea, cattle slurry, and solid and composted manures. Can J Soil Sci. 73:253–266. <https://doi.org/10.4141/cjss93-027>