



Full-length article

Conceptual design and development of a progressive cavity pump for extrusion-based additive manufacturing applications



Yusuf Furkan Ugurluoglu ^{a,c,*}, Ana Marina Ferreira ^a, Piergiorgio Gentile ^a, Javier Munguia ^b

^a Newcastle University, School of Engineering, Stephenson Building, Newcastle upon Tyne, NE1 7RU, United Kingdom

^b University of Warwick, School of Engineering, Coventry CV4 7AL, United Kingdom

^c Necmettin Erbakan University, Department of Mechanical Engineering, Meram, Konya, 42090, Turkey

ARTICLE INFO

Article history:

Available online 7 September 2023

Keywords:

Progressive cavity pump (PCP)
Additive manufacturing (AM)
Conceptual design
Bioprinting
Material extrusion

ABSTRACT

The present study aimed to develop a low-cost, scalable, easy-to-clean extrusion system based on the progressive cavity pump (PCP) principle for extrusion-based additive manufacturing, with a specific focus on bioprinting. Therefore, the study proposes a spiral development model to achieve a novel PCP with the help of additive manufacturing (AM). An application programming interface was developed to enable quick design iterations. User requirements were determined through literature research, a user questionnaire and interviews. Consequently, three novel PCP concepts were designed and developed using the developed model, and the proof of concept for the selected PCP design was presented.

© 2023 The Author(s). This is an open access article under the CC BY license (<http://creativecommons.org/licenses/by/4.0/>).

Introduction

Additive manufacturing (AM) has gained significant attention among hobbyists, academia and industry in the last decade. AM is a layer-by-layer fabrication process from a computerised 3D model data using liquid, solid, powder, gel and paste materials. AM processes can be classified into seven categories: vat photopolymerisation, binder jetting, powder bed fusion, sheet lamination, direct energy deposition, material jetting and material extrusion [1].

In the material extrusion process, the material is dispensed in a controlled manner through a nozzle to make objects. The standard methods in material extrusion can be listed as fused filament fabrication (FFF), direct ink writing (DIW) and extrusion-based bioprinting (EBB). While FFF technology uses solid polymer material in filament or pellet form, DIW uses paste materials, and liquids and pastes are used in EBB.

Bioprinting emerged due to the need for Tissue Engineering (TE) approaches, and the technology consists mainly of three subjects: TE, Mechanical Engineering and Material Science. TE aims to fabricate artificial tissues or organs to mimic the real environment of the

human body [2]. Bioprinting methods can be classified as droplet-based, laser-based and EBB.

EBB is in demand technology as it allows wide material selection (viscosity range from 0.3 to 30 Pa s), high manufacturing speed and a controllable printing environment [3–5]. EBB may be classified in terms of material driving systems into pneumatic, piston, auger screw and progressive cavity pump (PCP) driven. Fig. 1 shows the available designs of EBB technologies, each with advantages and limitations.

Pneumatic-driven extrusion, which uses regulated air pressure, provides precise control over the extrusion process, allowing for controllable extrusion force and flow rate. However, it is important to consider the impact of the remaining material volume in the cartridge on accuracy. Additionally, including a pressure control unit increases the overall system cost and requires additional safety precautions compared to mechanical-driven systems [5].

Piston-driven extrusion, on the other hand, offers high precision and control. The direct connection between the motorised piston and the syringe or cartridge plunger enables fine-tuned extrusion force and volume control. However, highly viscous materials may require higher forces, decreasing the precision and control and limiting the range of suitable materials for this method. Furthermore, syringe cartridges restrict the dispensing volume of biomaterials [6–8].

Auger screw-driven extrusion is particularly suitable for dispensing highly viscous biomaterials. The rotating screw mechanism effectively transports and extrudes the media. However, it is not

* Corresponding author at: Newcastle University, School of Engineering, Stephenson Building, Newcastle upon Tyne, NE1 7RU, United Kingdom.

E-mail address: y.f.ugurluoglu2@newcastle.ac.uk (Y.F. Ugurluoglu).

¹ 0000-0002-6266-0165

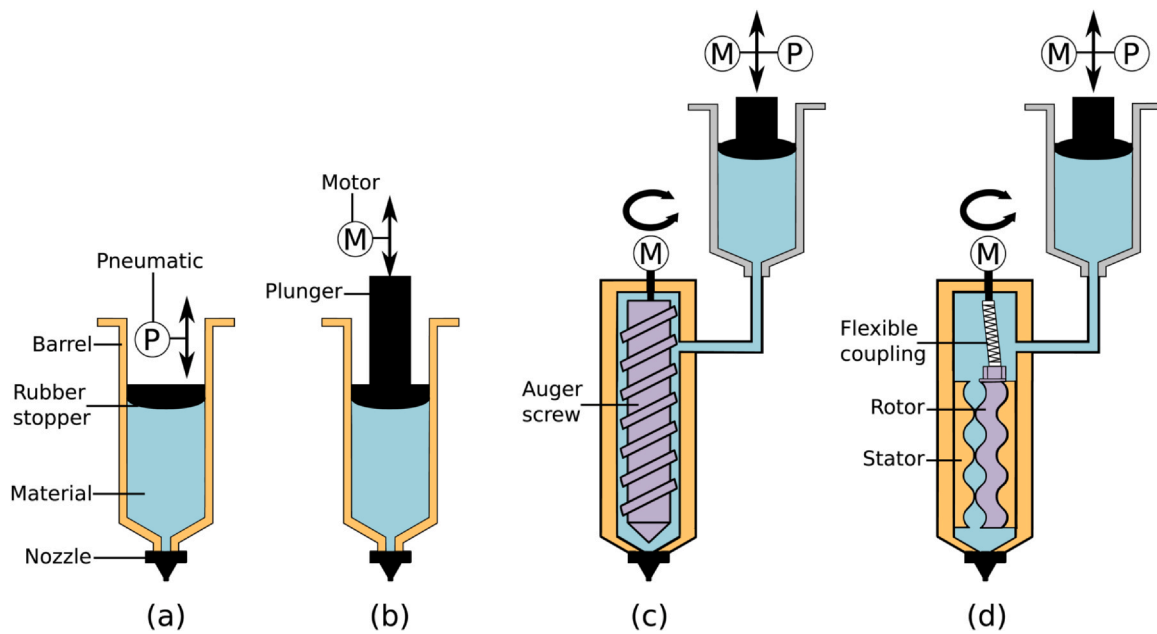

Fig. 1. Extrusion-based bioprinting systems. (a) Pneumatic driven, (b) piston-driven, (c) auger screw-driven, and (d) progressive cavity pump.

well-suited for low-viscosity materials, which can leak through the nozzle due to the continuous flow path. This limitation restricts the applicability of auger screw-driven extrusion in bioprinting scenarios involving low-viscosity materials [5].

PCPs are exceptional at dealing with biomaterials that have a high viscosity. They offer advantages in terms of material extrusion. However, there are limitations associated with PCPs that need to be considered. These include high system costs, cleaning and assembly difficulties, and a large dead volume that can impact material usage efficiency [6,9].

The study of PCPs is crucial because they are excellent at handling biomaterials with high viscosity and have advantages for material extrusion. However, it is important to acknowledge the limitations of PCPs, such as their expensive system costs, challenges in cleaning and assembly, and the presence of a considerable dead volume that can affect the efficient uses of materials [6,9]. Exploring the existing literature on PCPs can offer valuable insights into their potential applications within additive manufacturing.

PCP was invented by the French engineer René Moineau in 1930, and it can be referred to in the literature as progressive cavity pump, progressing cavity pump or Moineau pump [10]. When these terms are searched on the Web of Science, there are 113 articles in total, and 58, 52 and 3 articles are found for progressive cavity pump, progressing cavity pump and Moineau pump, respectively. While many are related to high-speed and high-volume fluid pumping, only six articles related to AM [6,7,11–14].

Commercially available PCPs have received considerable attention in recent academic research due to their high accuracy in soft material dispensing [7,9,12,15]. The PCP mechanism produces cavities to move the media without deformation; consequently, it transfers fluid through the progress, a sequence of small, fixed shapes and discrete cavities. PCPs have a great potential to provide better dispensing quality than pneumatic and piston-driven methods. Recent studies have shown that PCPs offer a valuable tool to improve the accuracy of EBB [6,9,12].

Existing research recognises the critical role of the extrusion unit [6]. It has been noted that PCPs provide 41 times higher accuracy and 80 times higher precision than pneumatic extrusion, regardless of the biomaterials' rheological parameters [6]. It was also suggested that bioprinting applications benefit from a specifically designed

PCP, considering the current limitations of the large dead volume, high volume flow and cleaning difficulty. Several studies have reported similar future works for commercially available PCPs, including developing an open-source PCP to decrease costs and adapting the technology for multi-material 3D printing [9,12].

A recent study aimed to develop a PCP for ceramic and pellet extrusion by combining an auger screw and a PCP into a single design [14]. While the study has shown some successful printing attempts, a full-functional PCP could not be proposed [14]. Maker movement was another community that showed interest in developing an open-source PCP-based ceramic extruder [16]. Most of their attempts have been to build an extruder using the existing PCP mechanism; however, there is no evidence of success that can be seen in the literature. Recently, Yeh et al. studied the stator material hardness to develop a soft-matter PCP for high-viscosity fluids [17]. Although the stator was successfully developed and tested, the scope of the research could have been more expansive because the exerted side loads on the stator wall were disregarded. In addition, no known research has attempted to consider the complex nature of the PCP mechanism to use as an AM extruder unit. Consequently, there is a need to better understand and explore the working mechanisms of PCPs in the context of AM extrusion.

The previously described limitations have attracted the attention of the dispensing industry. Viscotec company has recently developed the Puredyne kit b pump to meet the bioprinter user needs of single-use and precise dispensing for low to high-viscosity material [18]. However, what is not yet clear is the actual performance of the pump because it uses a pneumatic control unit, which could make the pump non-volumetric. This view is supported by research mentioning that the pump performance did not show promising results compared to pneumatic extrusion [19].

In summary, much of the current literature on printing with PCPs pays particular attention to the need for a better PCP for EBB. While there is a recent advancement in industry and research, there are still some unanswered questions regarding the working mechanism of PCPs.

The aim of this study was to develop a low-cost, scalable, easy-to-clean extrusion system based on the PCP principle to overcome the mentioned limitations. The key research question of this study was whether or not there is a better unknown PCP mechanism for

extrusion-based additive manufacturing, with a specific focus on EBB. Therefore, a spiral development model was proposed to explore the PCP working mechanism with the help of AM. An application programming interface (API) was utilised for Fusion 360 CAD software to enable rapid design iterations. Subsequently, user requirements were determined through literature research, a user questionnaire, user interviews and redesigning of a conventional PCP to explore the working mechanism. Finally, three PCP concepts were designed and prototyped to meet the EBB requirements and evaluated by 3D object printing trials.

Methods and materials

PCP development process

PCPs have a long history; however, the first design’s working mechanism and core components have almost never changed. Developing a new product requires extensive research on problem definition and many iterations of possible solutions. The use of the spiral development model allows the generation of various concepts quickly with the help of AM. Therefore, it was more likely to find an innovative solution for the current drawbacks of dispensing PCPs by obtaining insight from each concept. Consequently, a spiral development model was established in this research.

The spiral process was first proposed for software development, enabling a faster product development cycle due to the quick prototyping features of software technologies [20]. Ullman adapted the spiral process for mechanical product development [21]. However, it was not widely used due to the slow manufacturing speed of those days. Recent developments in the field of AM have resulted in affordable machines and high-quality end products for experimental tests. Consequently, these advancements have led to a renewed interest in the spiral product development process [22–24].

In this research, a spiral development model was developed based on previous research, as seen in Fig. 2[21,25]. The model shows the development process of a novel PCP for EBB; however, it can be generalised as a spiral product development model.

The developed spiral model can mainly be divided into three main phases: initials, concept, and product development (see Fig. 2).

The initials phase begins with the problem definition, defined as the high cost of PCP and control unit, cleaning difficulty, and scalability of PCPs as mentioned in the literature [6,9,12]. These drawbacks were mentioned in the introduction, forming the basis of this research. Based on the problem definition, background research was conducted, including literature research, a user questionnaire, user interviews, syringe pump evaluation and redesigning of a conventional PCP. In the final step of the initials phase, the collected information was expressed as technical terms and specifications to produce pump requirements. Consequently, these requirements were used to develop the requirements of the concept development phase.

The concept development phase of the spiral model consists of many iterations until the approval of a concept that meets the pump requirements. In the redesigning step, a conventional PCP concept was developed to understand better the fundamentals of PCPs, including the working principle and essential features. Subsequently, various concepts were developed by collecting information from the redesigning phase and previous concepts. These concepts were evaluated to produce a better PCP design, either changing the working mechanism or cross-sectional geometry design of the rotor and stator. Detailed information on the prototype evaluation step is given in the following section. The product development phase begins when a concept meets the defined pump requirements. This research contains the initials and concept development phases of this model. It is important to note that the spiral development model can continue forever due to its iterative nature. For this reason, the project manager should decide when to move to the next stage to use the model efficiently.

User questionnaire and user interviews

Bioprinter user requirements were obtained by using a questionnaire and user interviews. These requirements are used to determine known limitations and user expectations of bioprinters. The bioprinter user experience questions are shown in Table 1, designed to collect the expected bioprinter features.

Questions 1 and 2 asked participants to rate the importance of extrusion head and bioprinter features on a 5-point Likert scale.

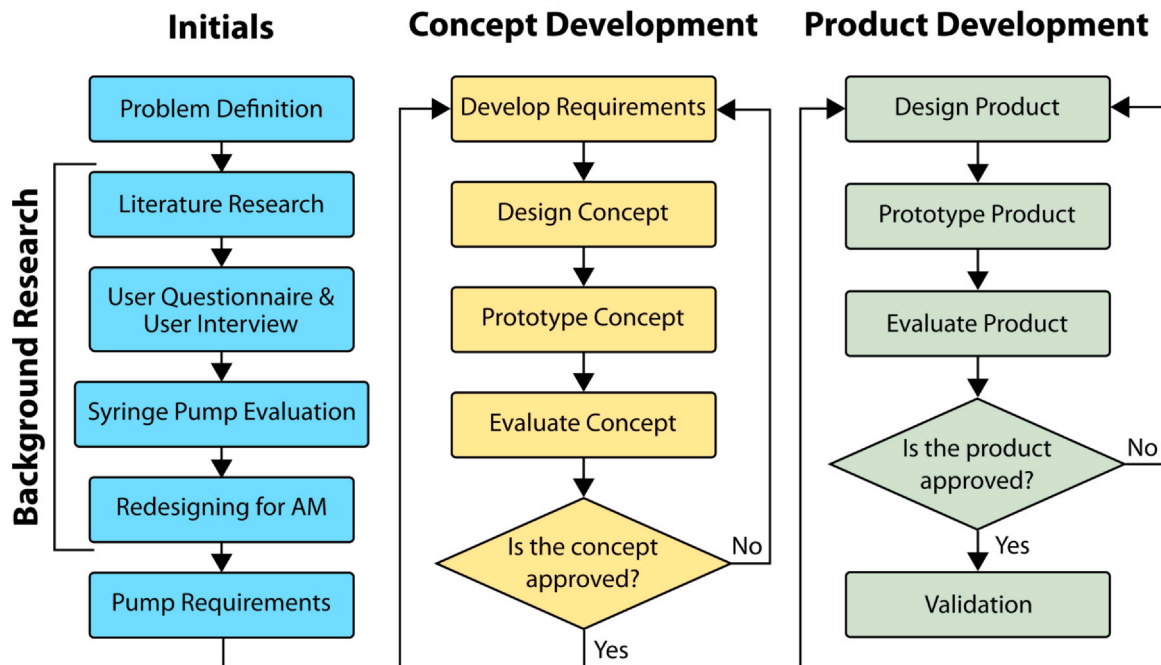

Fig. 2. Spiral development model of a progressive cavity pump for extrusion-based bioprinting.

Table 1
User questionnaire.

Questions	
1	Could you please rate the importance of extrusion features (hydrogel, filament, pellet and multi-material)?
2	Could you please rate the importance of the following features (UV light for cross-linking, print head temperature control, print bed temperature control, enclosed and controllable printing environment)?
3	How many materials do you need to print simultaneously in a process?

Question 3 was designed to find out the multi-material printing needs of users.

The user questionnaire was circulated to 50 academics actively conducting research in the area of bioprinting, and 20 responses were received. User interviews were conducted with five bioprinter users from two different universities. The same questionnaire and the question about problems they face when using a bioprinter were asked to identify the types of problems.

The user questionnaire was performed on an online survey platform, and user interviews were conducted face-to-face and online.

Cross-section generation of the progressive cavity pump

The inner and outer gears of PCPs are typically designed using hypocycloid, epicycloid, and hypo-epicycloid geometry generation methods. The hypocycloid theory and 3D vector approach were utilised in this research, as they are among the most commonly used methods for PCP design [10,26]. Nguyen et al.’s research provides detailed equations for generating modified hypocycloid, which has been further enhanced in this article by adding a tolerance factor to the original equation [26]. To avoid redundancy, only the final equation is presented here, and the detailed explanation of modified hypocycloid generation can be found in the related research [26].

Figure 3 shows the generation of the 4-lobe PCP gear cross-section using an extended hypocycloid generated by a 3D vector approach, along with the original hypocycloid and modified hypocycloid with cusps. The cross-section geometry of inner and outer gears in PCPs is generated by extending a hypocycloid shape. A hypocycloid is a special plane curve created by the trace of a fixed point on a small circle rotating in a larger circle. To obtain a hypocycloid, a certain ratio exists between the smaller and larger circle radius. The ratio should be an integer to obtain a closed hypocycloid, and it also defines the number of lobes in the PCP. The 3D vector approach is used to generate the cross-section geometry of the inner and outer gears from a hypocycloid. This approach calculates the position, tangent, and normal vectors to obtain an extended modified hypocycloid. The PCP consists of the stator and rotor components. The stator always has one more lobe than the rotor to produce enclosed cavities for pumping action. A modified hypocycloid is

created using two parametric equations, and cusps are added at each corner to obtain a PCP cross-section.

The parametric equations of a modified hypocycloid can be defined in terms of the initial and extended coordinates, the radius of the generator circle, the number of lobes, the diameter of a cusp, and the tolerance amount. The initial coordinates of the hypocycloid at angle θ are denoted by $x(\theta)$ and $y(\theta)$. The extended coordinates of x and y at angle θ are denoted by $x_n(\theta)$ and $y_n(\theta)$, respectively, where Δx and Δy represent the amount of extension. The radius of the generator circle is represented by r , the number of lobes by N , the diameter of a cusp by d , and the tolerance amount by w . The equations for the extended coordinates of the hypocycloid can then be written as follows:

$$\begin{aligned}
 x_n(\theta) &= x(\theta) + \Delta x \\
 &= r [(N - 1)\cos\theta + \cos((N - 1)\theta)] + \frac{[\cos\theta - \cos((N - 1)\theta)] d}{\sqrt{2}\sqrt{1 - \cos N\theta}} \frac{d}{2} \\
 &\quad + \frac{w}{2}
 \end{aligned}
 \tag{1}$$

$$\begin{aligned}
 y_n(\theta) &= y(\theta) + \Delta y \\
 &= r [(N - 1)\sin\theta - \sin((N - 1)\theta)] + \frac{[\sin\theta + \sin((N - 1)\theta)] d}{\sqrt{2}\sqrt{1 - \cos N\theta}} \frac{d}{2} \\
 &\quad + \frac{w}{2}
 \end{aligned}
 \tag{2}$$

It should be noted that the modified hypocycloid approach has some known defects due to offsetting the base geometry and adding cusps [27]. As previous research has shown, these defects occur between the cusps and extended hypocycloid intersection points, resulting in a millimetre-sized defect for meter-sized pumps and a micron-sized defect for centimetre-sized pumps [28]. Despite these defects, the elastomeric stator can tolerate them and enable successful operation [28]. If there is a clearance between the stator and rotor, the extruded material can fill the gap and maintain a seal. Therefore, these defects may not significantly affect the pump’s performance, especially in the context of concept development, where the error margin is insignificant.

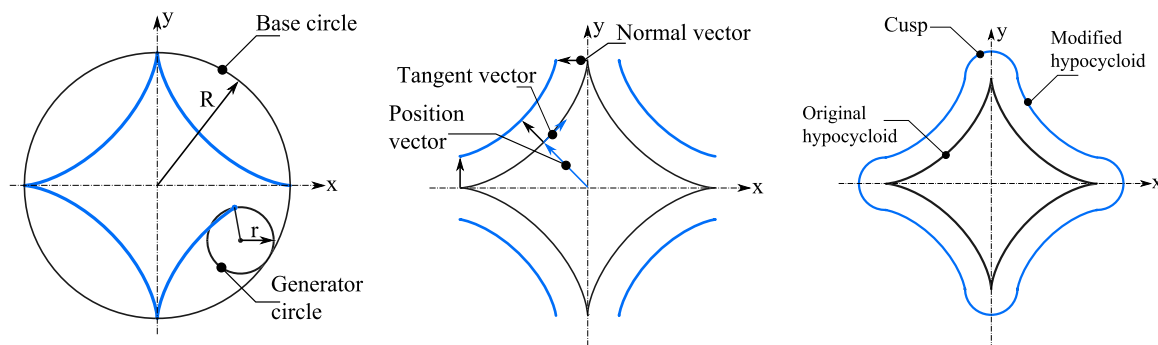

Fig. 3. Generation of the 4-lobe PCP gear cross-section. (Left) Generation of 4-lobe hypocycloid. (Middle) Generation of modified hypocycloid (extended hypocycloid with cusps) using a 3D vector approach. (Right) Original hypocycloid and modified hypocycloid for the 4-lobe gear.

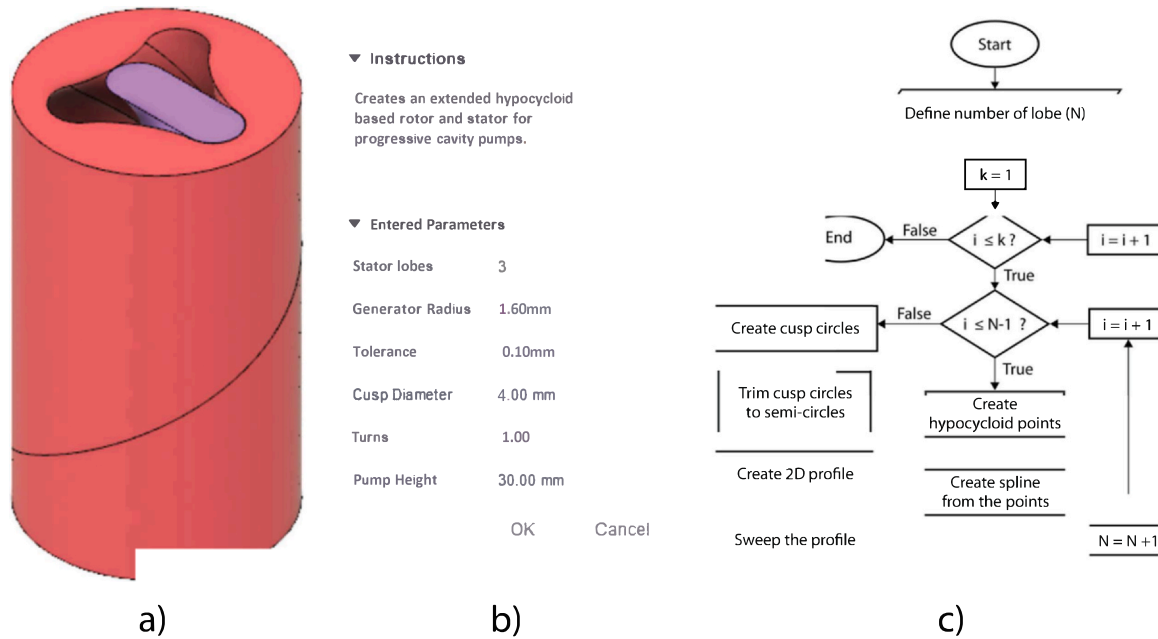

Fig. 4. The figure shows the application programming interface (API) for rotor and stator designs of PCPs. a) Displays the generated bodies, b) shows the user interface, and c) presents the flowchart of the API.

Parametric design of rotor and stator

API was employed to integrate the modified hypocycloid equations into the Fusion 360 CAD software due to the extensive iterations involved in the concept development phase. The API was based on a previous work of hypo-epi cycloidal PCP design [29]. API calculates and connects the hypocycloidal points and generates cusps to obtain an enclosed gear geometry. Subsequently, rotor and stator bodies were generated by adjusting the number of rotations in a given length.

Fig. 4 shows the generated bodies on the image (a), input parameters on (b) and API flowchart on the image (c). The functions of input parameters are:

- Stator lobes: Required number of stator(or outer gear) lobes.
- Generator radius: Radius of the generator circle.
- Tolerance: Clearance between gears.
- Cusp diameter: Diameter of the semi-circles.
- Turns: Number of rotations in a given PCP length.
- Pump height: Length of the PCP.

The API is programmed to generate a series of operations step by step, and the flowchart can be seen in Fig. 4(c). Operations begin with the definition of the number of lobes and input parameters. The parameter *k* is the minimum limit of iterations, and *i* is the temporary variable used to store the integer value of the current position in the range of the for loop. The process for generating a PCP gear involves creating a 2D sketch, generating splines from the modified hypocycloid equations, adding circles, trimming to create cusps, and obtaining a cross-section of an N-lobe PCP gear. The solid body of the gear is then formed using the sweep function.

Redesigned conventional PCP evaluation

In the redesigning phase of the spiral development model, a conventional PCP was designed using a 2:1 lobes arrangement and double universal joint. In-house FFF prototyping was used to obtain all components except fasteners.

The redesigned prototype was evaluated to obtain necessary information about the limitations and fundamentals of PCPs. The design's coupling, gears and sealing performance were analysed to find an innovative solution. In addition, the part quality and accuracy of the FFF machine prototype were evaluated for the dispensing evaluation phase.

Concept prototyping

The Ultimaker 3 was used to print designed concepts, and the printing parameters are as follows:

- Nozzle diameter: 0.4 mm
- Layer height: 0.15 mm
- Printing temperature: 200°C
- Printing speed: 50 mm/s

Polylactic acid (PLA) filament was used to produce most PCP components in the concept prototyping. It was the primary prototyping material in this research due to its biodegradable feature, low cost, and easy printability by the fused filament fabrication (FFF) technique.

PLA filament with an average density of 1.24 g/cm³ and diameter of 2.85 ± 0.10 mm was purchased from RS Components (UK).

Concept prototype evaluation

In the concept development phase of the spiral development model, the aim was to explore a novel working mechanism that meets the product requirements of EBB. PCP concepts were designed and prototyped using collected information from the redesigning phase and in line with the knowledge gained from the previous concepts.

The concept evaluation was performed by manipulating the rotor and stator to observe a satisfactory rotation mechanism and liquid transfer. The manipulation was carried out manually or with a stepper motor. The extrusion ability was tested by filling the inlet of PCPs with petroleum jelly, and the outlet was observed for extrusion. In addition, tap water was used to observe pump leakage and sealing

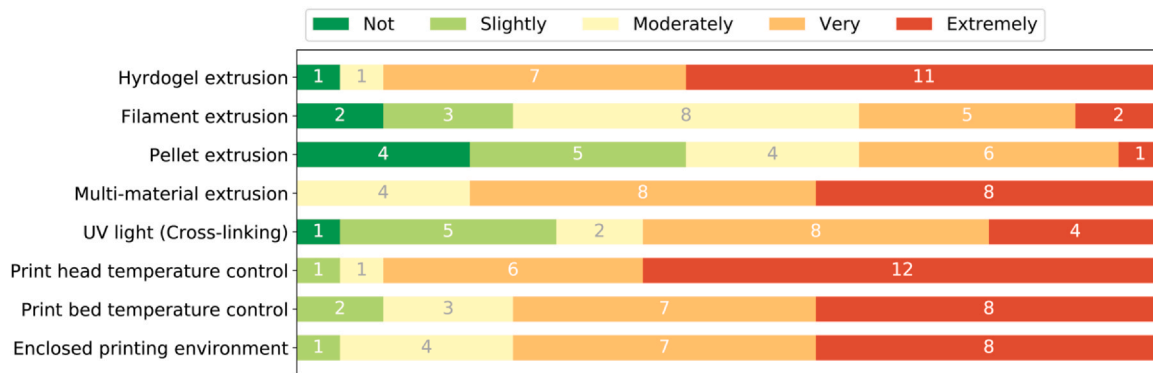

Fig. 5. Importance level of bioprinter features.

performance. Consequently, the primary evaluation areas can be defined as:

- Coupling
- Sealing performance
- Dispensing ability
- Gears arrangement

Dispensing test material

Nivea Creme is commonly used as a dispensing printer test material because of its shear-thinning and fast shear-recovery behaviour [30]. However, the syringe-filling process of the Nivea creme causes air-filled cavities and makes the extrusion process unstable. For this reason, petroleum jelly, which has shear-thinning behaviours, was selected, and it can be melted and filled in the syringe without air bubbles [31].

Vaseline Original Petroleum Jelly was purchased from Boots (UK). It was used as a dispensing fluid in the 3D printing trial of the selected concept evaluation.

Results and discussion

User questionnaire and user interviews

In the user questionnaire, three main questions were asked to define user expectations from a bioprinter regarding material printing ability and machine features. In Fig. 5, the first four results show the importance of printing materials for bioprinter users. The last four results show the importance level of machine features for bioprinter users.

Figure 5 shows that the most significant demand is for hydrogel extrusion compared to the filament and pellet extrusion. In addition, multi-material extrusion is seen as a required feature for bioprinter users. Concerning this result, the question of “how many materials are needed for a process” was asked. The results revealed that nine participants indicated three to four materials and eleven participants found one to two materials enough.

It is apparent from the results of the last four questions that all features are important for the vast majority of bioprinter users. The only significant difference is the high importance of the print head temperature control. Although other machine features, such as print head temperature control, were considered important for bioprinter users, these findings are less directly relevant to this project. Nonetheless, they may provide useful insights for other researchers working on different aspects of bioprinter design and development.

The results of the user questionnaire and interviews offer valuable insights into the general requirements of bioprinter users. However, it is crucial to note that this research focuses specifically on developing a PCP pump for bioprinter users. Therefore, the

analysis of the questionnaire results has centred on identifying the material printing requirements relevant to this development process.

One of the most relevant findings from the user questionnaire is the high demand for hydrogel extrusion among bioprinter users, as demonstrated in Fig. 5. This outcome is particularly relevant to this study as it emphasises the importance of designing a PCP pump that can extrude hydrogel materials effectively.

Redesigning a conventional PCP for additive manufacturing

The main components of PCPs can be divided into gears and coupling. Gears are the rotor and stator, and coupling transfers power from the motor to the rotor. Various gears arrangements, including 2:1, 3:2, and 4:3 lobes, and the 2:1 lobes are the most common in dispensing pumps. Fig. 6 shows a commercial 2:1 lobe PCP with a flexible coupling, and this design is the most common one in the industry.

PCPs used in the dispensing industry have elastomeric stators to provide an interference fit between gears and clearance fit pumps used in high-speed pumping. While the interference fit design is a common approach, the clearance fit design was chosen due to the available FFF prototyping method. Petroleum jelly was used to evaluate the dispensing action because the clearance between the rotor and stator can be filled by fluid flow.

Two types of commonly used couplings in PCPs are double universal joint or flexible coupling for power transmission from the motor to the rotor. Commercial PCPs use flexible coupling; however,

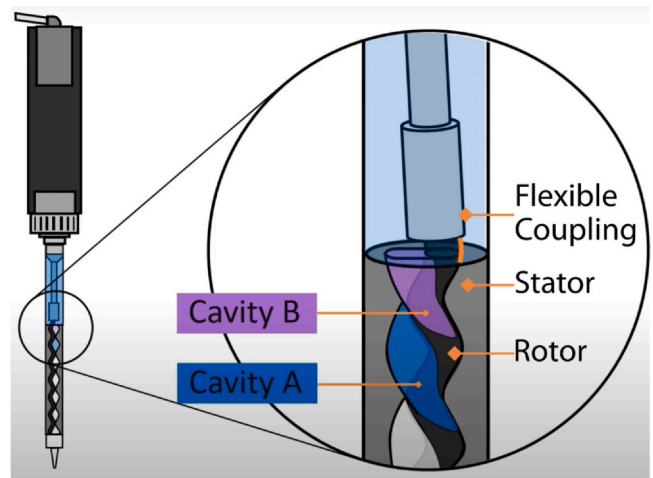

Fig. 6. Progressive cavity pump on the left and a detailed view of the rotor, stator, flexible coupling and cavities on the right [32].

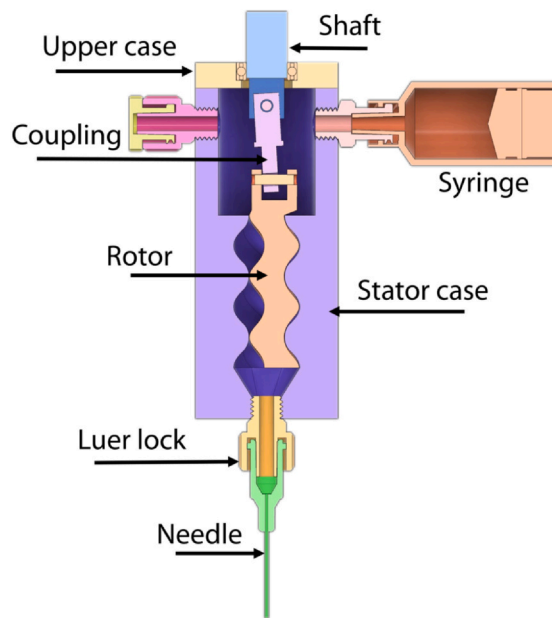

Fig. 7. The redesigned prototype of a conventional 2:1 lobe PCP, design layout and components are on the left, and the physical prototype is on the right.

the double universal joint mechanism was selected because it is easy to prototype and test.

The redesigned PCP can be seen in Fig. 7, and it consists of four components: (1) the upper case to hold the bearing, (2) the stator designed as the main case, which includes the inlet and outlet, (3) the double universal joint and (4) the rotor. The main design parameters are 1.5 mm generator radius, 7 mm cusp diameter, 30 mm stator pitch, 1.25 revolution and 0.2 mm clearance between gears.

The upper case holds the bearing, and the actuated end of the double universal joint was fitted into the bearing to enable balanced rotation. This design causes material leakage during the inlet filling operation and print retraction. The shielded bearing was used for the observation, which was an expected result. Therefore, leakage can be defined as the primary consideration point in the PCP design.

The inlet volume was observed as a limitation due to the high height compared to the pump length. While the PCP design works, inlet volume can be considered as a dead volume for a small amount of material dispensing. The coupling length limits the inlet volume, and this also limits the scalable PCP design. Therefore, the coupling can be considered one of the most critical components in the PCP design.

The double universal joint was used to enable horizontal movement of the rotor caused by the eccentricity of the pump. However, vertical movement of the coupling was observed due to the decreasing length of the coupling during horizontal movement. In addition, this jerky movement causes side loads to be exerted onto the stator during the rotor rotation and limits the stator material selection. This issue can be carefully evaluated for high-precision dispensing, and it can cause pulsation due to non-uniform clearance or interference between gears. While this problem can be solved using a telescopic universal joint, it restricts the scalable PCP design. Therefore, finding a solution for power transmission between the motor and rotor can be defined as one of the objectives in the concept generation phase.

Gears tolerance (0.2 mm) enabled easy rotation, and the 2:1 lobes arrangement worked as expected. The stator, inlet and outlet sections were designed as a single component to simplify the PCP design.

Luer lock connectors were used in the design for easy syringe and needle installation, and they worked as expected. Therefore, they

will be used in the concept generation phase as they are standard connectors in the biomedical and dispensing industry.

PCP requirements

The main limitation in EBB technology can be defined as start and stop printing accuracy problems. In other words, when the user initiates the print, it does not begin immediately, and when the print finishes, the liquid continues to leak. There are two main reasons for this problem. The first one is the material-related reason, which stems from the rheological properties of biomaterials, including non-Newtonian behaviours, yield stress and viscosity. The second one is the extrusion unit-related reason, which is the volume of pressurised material. This pressure causes a low printing accuracy and generates a back-flow inside the pump. Therefore, a requirement can be minimising the outlet volume and clearance between the gears.

We can describe two different motions in the working principle of PCPs, which are rotational and transitional. In commercial PCPs, the rotor carries these two motion types, and flexible coupling provides power transmission from a motor to the rotor. The reason to use a flexible coupling is the uneccentric motion of the rotor. We can define two problems of using a flexible coupling: the exerted force on the stator's side walls and the axial movement from the stator inlet to the outlet. These problems cause flow pulsation and low dispensing accuracy.

Bioprinter user needs and commercially available PCP limitations were investigated, and it was concluded that the following requirements could be considered when designing and developing PCP concepts:

- Easy to clean
- Scalable design
- Sealing the PCP
- Cell-friendly extrusion

Concept 1: outer gear-actuated PCP

The PCP working mechanism was selected as a focusing point in the first concept development. After intensive research, an

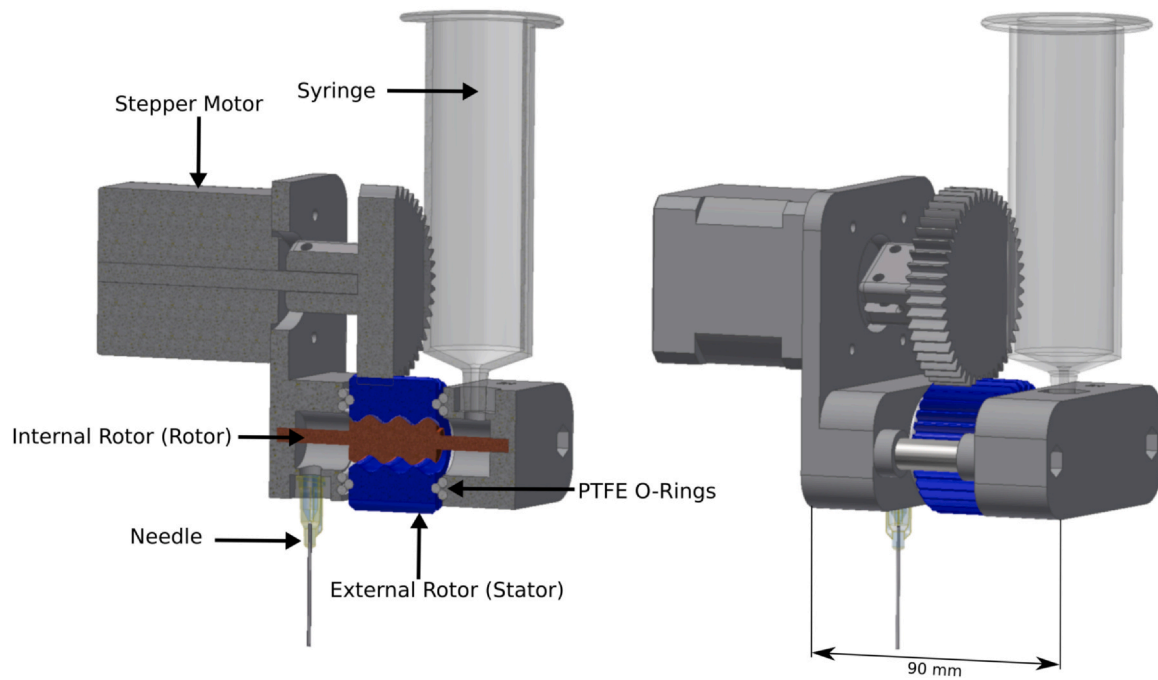

Fig. 8. The figure shows a section view and an isometric view of the developed outer gear-actuated PCP. The section view on the left illustrates the pump components and the isometric view on the right provides a clear visual representation of the entire pump.

alternative working mechanism was discovered by changing rotary gears from the inner gear to the outer gear (see Fig. 8).

The PCP was designed with hypocycloid geometry as conventional PCPs. This solution enables the scalable design of a PCP, and scaling can solve the mentioned limitations of conventional PCPs.

The outer gear-actuated PCP design consists of 2:1 lobes of outer and inner rotating elements, which are a stator and rotor in conventional PCP. The inner rotor was inserted into housings on both ends to obtain enough clearance for axial movement. The external rotor motion was aligned using six PolyTetraFluoroEthylene (PTFE) O-rings, which provided sealing. The design was produced using the API with the following parameters: 2 mm generator radius, 0.2 mm tolerance, 10 mm cusp diameter, 1.25 rotation and 30 mm pump height.

Gears have a specific rotation ratio: the inner gear rotates two times the outer gear. In this design, the outer gear is driven by the NEMA17 stepper motor, and the inner gear motion was expected to be automatic due to axis restriction. However, this could not be achieved due to the rotation ratio between gears; therefore, the design did not work as expected. In the concept evaluation, required rotation was observed in a few attempts, but generally, it was not satisfactory.

The PCP alignment was designed as vertical to prevent the cell settling and nozzle clogging in the bioprinting process due to the gravitation. Luer-lock adapters worked as intended, and they enabled easy syringe connection.

Additively manufactured gears were designed as chamfer edges to enable the fit between the motor gear and outer gear. The trial of using PTFE o-rings to align and seal the PCP was partially successful. Required axial alignment and rotation were provided; however, the sealing required high compression, and this caused a high torque requirement. When the compression was increased, the required torque increased due to friction load between PTFE o-rings. Therefore, the selection of PTFE o-rings did not meet the sealing requirement, and the solution can be to use a sealed bearing and rotary shaft seal.

In summary, the rotation ratio between gears should be considered carefully, and there can be two solutions. First, using

simultaneously driven gears to provide a fixed rotation ratio. Second, changing the actuated gear from outer to inner and increasing the number of lobes increases the contact point between gears. The conceptual phase continued with these two concept designs to solve these problems.

Concept 2: synchronised actuated PCP

The synchronised actuated PCP design has a similar mechanism as the previous prototype; however, in this design, the inner gear was actuated with the outer one by transmitting power using spur gears (see Fig. 9).

In the design, a 2:1 lobes arrangement was selected, and spur gears were used to provide synchronised rotation of the inner and outer gears with a specific ratio. The ratio is two times the inner gear rotation for one outer gear rotation. Gears were 3D printed with 1 MOD and 20-degree pressure angle design parameters. One of the 30 teeth gears was connected to the motor shaft to drive the other 30 teeth gear, and this rotation was transmitted to the outer gear via 25 teeth and 50 teeth gears. Therefore, the ratio of two inner to one outer rotation was obtained for the PCP prototype.

The inlet housing was designed to act as a bushing for outer gear housing, and two washers were used to seal the PCP pump. The bushing type of housing was designed to provide easy assembly of the PCP prototype. Luer-lock adapters were used to connect a syringe and a needle for easy assembly. The design was produced using the API with the following parameters: 2 mm generator radius, 0.2 mm tolerance, 10 mm cusp diameter, 2 rotations and 50 mm pump height.

In the prototype evaluation, a NEMA17 stepper motor was used to drive the PCP, and successful rotation was obtained. Subsequently, the petroleum jelly was filled to the inlet volume for the material dispensing test, and the PCP could dispense the material through an 18-gauge needle. However, the subsequent trials caused the failure of the inner gear due to the missing rotational ratio of the drive gears. This issue can be solved by using precision-manufactured drive gears, inner gear and outer gear; however, this increases the cost of the PCP.

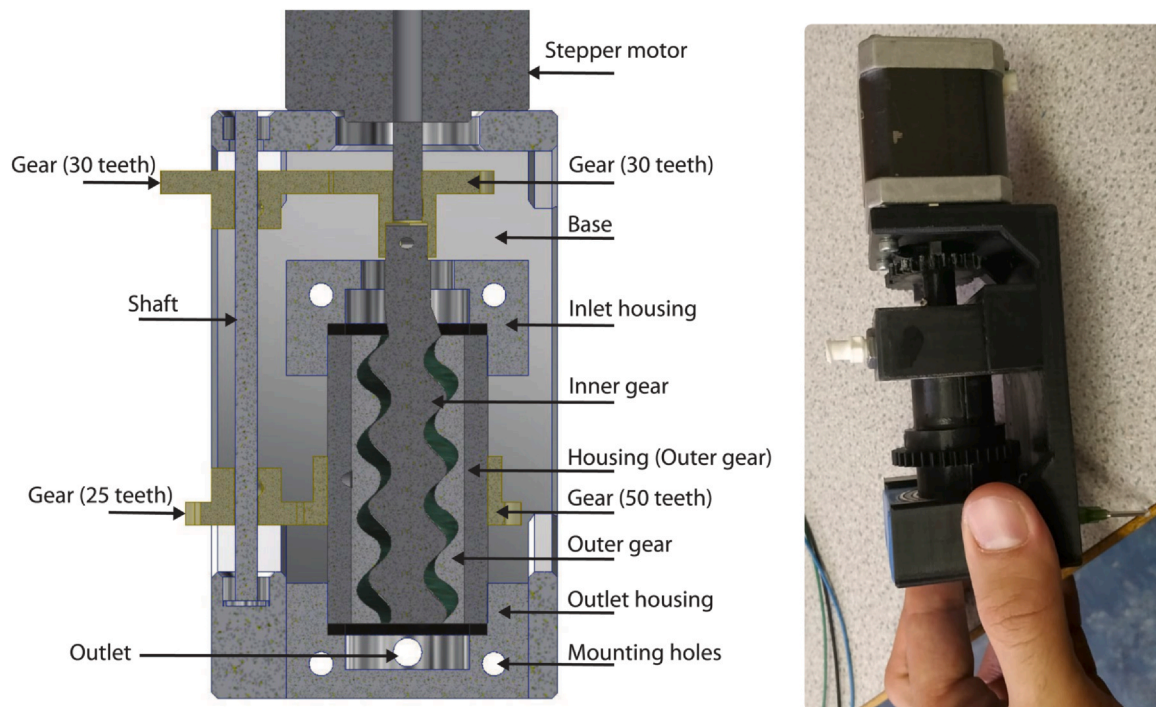

Fig. 9. PCP with the synchronised drive of inner and outer gears. (Left) Design and explanation of the PCP with the synchronised drive of inner and outer gears. (Right) Functional prototype of the PCP with the synchronised drive of inner and outer gears.

In summary, two main limitations can be concluded from the synchronised PCP prototype. First, the high cost of precision manufacturing, and second, the complicated assembly of the components. These limitations are against the defined requirements of easy-to-clean and cell-friendly extrusion. In other words, the excess number of components makes the PCP difficult to clean and assemble, and precision manufacturing obligation restricts the disposable PCP option. Therefore, the direction of the next prototype design will be defined as decreasing the number of components and making a single gear-actuated PCP.

Concept 3: inner gear-actuated PCP

Various mechanisms were designed and prototyped in the previous three concepts to achieve defined requirements. While they could be considered partially successful, they could not achieve the defined PCP requirements. This concept used previously gained experiences to design a novel PCP with the defined requirements.

The inner gear-actuated PCP design and prototype can be seen in Fig. 10, and the name of this concept comes from the actuated part of the PCP. In concept two, the externally actuated PCP was designed; however, it was not satisfied with the desired rotation due to the greater rotation speed of the outer gear than the inner one. In addition, the contact point between gears was not enough to actuate the non-driven gear. In this design, the inner gear was actuated to rotate the outer gear, and the contact points were increased by selecting a 4:3 lobes arrangement to overcome the limitations of the second concept.

The PCP design consists mainly of four components: inner gear, outer gear, case and outlet. The main advantage of the design is the self-alignment of inner and outer gear due to the gear matching between them. The number of components was minimised to make it easy to clean and assemble, and this can be the design even disposable with the help of mass manufacturing by reducing the PCP cost. Apart from the main components, Luer-locks were used to enable easy syringe and needle connection, and a flexible coupling and square key steel were used to transfer power from the stepper

motor to the inner gear. In addition, nitrile rubber o-rings were used between the case, outlet and PCP holder parts for sealing purposes.

The initial PCP evaluation was successfully conducted by rotating the inner gear to observe the outer gear rotation. Subsequently, the petroleum jelly was filled to the inlet of the PCP, and a successful dispensing action was observed without leakage. In the sealing performance evaluation, tap water was pushed through the inlet channel by closing other exits of the PCP. When the moving force was increased, a small amount of leakage was observed between the PCP holder and the case. The leakage issue can be solved by changing the arrangement of the o-rings, and the compression force of the flexible coupling can help to press the o-rings to enable leakage-free sealing.

One of the major advantages of the inner gear-actuated PCP concept is its simplicity and scalability. The design eliminates the need for any coupling, making it easy to manufacture and assemble. This not only simplifies the design but also reduces the risk of potential mechanical failure. During the design process, the methods of design for additive manufacturing were used. This approach involves designing parts specifically for 3D printing, considering the limitations and capabilities of the FFF printing technology. As a result, the PCP components were designed to print without support structures, reducing the complexity of the manufacturing process and minimizing material waste. Furthermore, an angle of fewer than 45 degrees was used where applicable to ensure that the parts could be printed with high quality and accuracy.

The results of this study demonstrate that the inner gear-actuated PCP concept satisfies most of the defined PCP requirements. The design is easy to assemble, consisting of only five components, which makes it easy to clean and cell-friendly. Furthermore, the use of injection moulding in mass manufacturing can reduce the cost of the pump. The design is scalable due to eliminating the coupling, although sealing issues must be addressed in further development. While the accuracy requirement could not be tested during concept development, the PCP's accuracy will need to be compared against other EBB methods to validate its performance. Overall, these results support the approval of the inner gear-actuated concept for further development and validation.

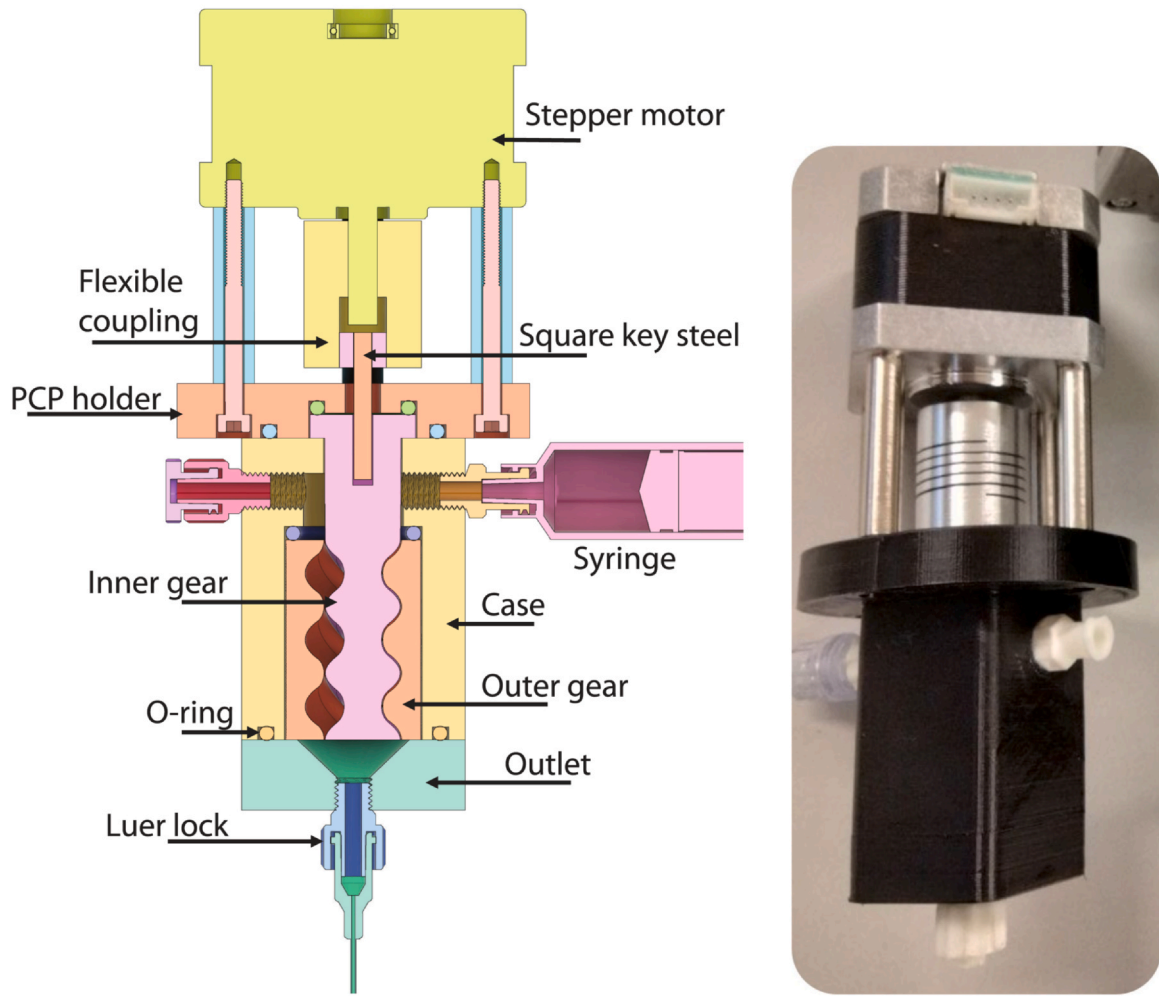

Fig. 10. Inner gear-actuated PCP concept with the design and components (Left) and functional prototype (Right).

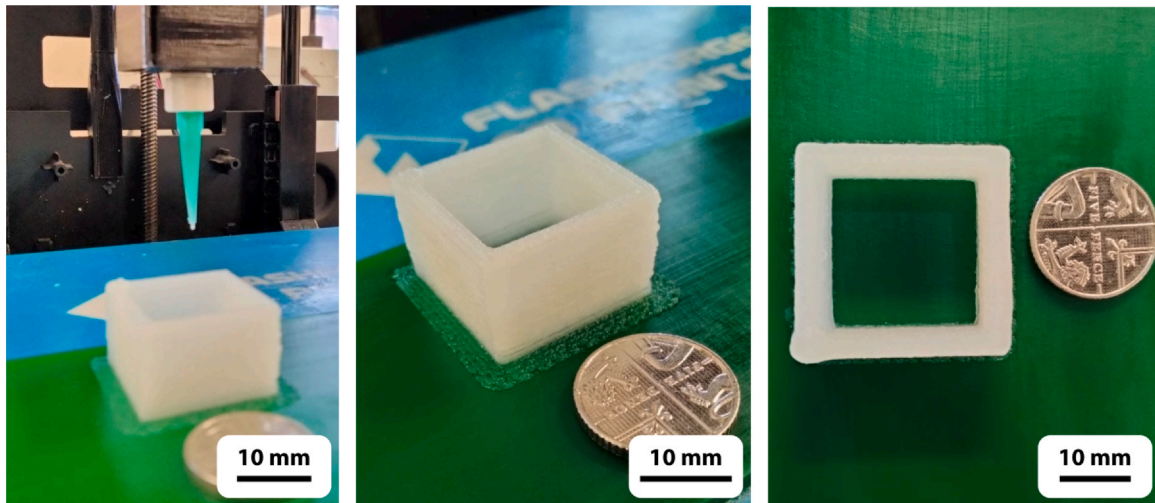

Fig. 11. The results of the hollow cube 3D printing test of inner gear-actuated PCP.

Evaluation of the inner gear-actuated PCP prototype

In order to confirm the effectiveness of the inner gear-actuated PCP design, 3D printing experiments were carried out on different objects. A hollow square cube was printed to assess the 3D printing capability of the developed pump. Additionally, the printing of ear

and nose and a 3D Benchy benchmarking objects using petroleum jelly were conducted to assess the developed unit’s capabilities further. In this section, the 3D printing results of these objects are discussed in detail.

The preliminary 3D printing test of the PCP was conducted by printing 30 layers of the hollow square cube, as can be seen in Fig. 11.

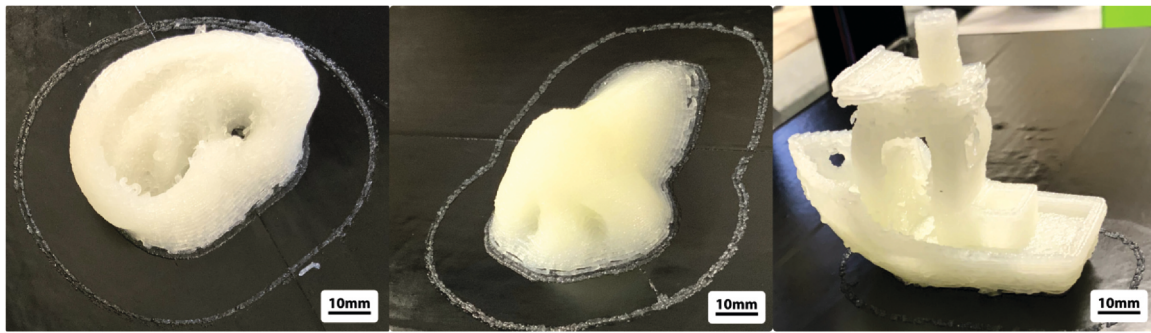

Fig. 12. The printing trial of the most popular 3D objects with a 18 G needle. The ear (left), nose (Middle) and benchy (Left). Mf extrusion unit was used to print the objects.

A syringe pump was used to feed the PCP, and the speed of synchronised driven motors was calculated based on the theoretical PCP flow rate and syringe pump specifications [33]. The square cube was successfully printed, and results showed that the inner gear-actuated PCP could print multiple layers. Therefore, the result of the experiment can be considered as a proof of concept to use as an EBB extruder.

Figure 12 shows the 3D object printing performance of the extrusion unit. A common benchmarking object used by the open-source desktop printing community is the 3D Benchy, and the printing of ear and nose objects can commonly be seen in the bioprinting literature [34]. Therefore, the experiment aimed to 3D print these objects using petroleum jelly to show the performance of the developed unit. The objects were sliced with a 0.4 mm layer thickness and printed using an 18 G tapered needle at 15 mm/s printing speed. The ear and nose were successfully printed except for the over-extrusion issue in the ear printing. The reason for the issue was the disabling of the retraction in the ear printing. Therefore, the nose was printed with a 1 mm retraction and showed promising quality.

The 3D Benchy contains various aspects that are difficult to print geometrically, including sloping surfaces, cylindrical shapes, curved overhangs, flat overhangs, and round horizontal holes. The 3D Benchy printing can be considered as successful if the overhang areas were disregarded, as the poor performance was observed due to the petroleum jelly viscosity. In other words, the vaseline could not withstand the load, and a bend was observed in the lower part of the roof. Besides, shape integrity was achieved for all 3D objects, and the chimney was successfully printed.

Overall, these results can be considered an initial evaluation of the developed PCP concept. The validation of the extrusion system by conducting accuracy and precision experiments is required to show the full performance of the pump.

PCP concepts

In the previous sections, we designed and developed a conventional PCP as well as three new concepts. The development process provided us with a deep understanding of PCP design, which enabled us to identify the most promising concepts for further use. Fig. 13 shows the design layouts of a conventional dispensing PCP (a) and the three developed concepts (b,c,d). In addition to these concepts, we also conceptualized a novel inner gear-actuated PCP arrangement, which is represented in the last layout of the figure.

The inner gear-actuated arrangements have the potential to overcome some of the limitations of bioprinting applications by evenly driving the rotor of the PCP. These arrangements can also address the limitation of stator material selection due to the applied force to the stator wall. However, the precision manufacturing required for the inner gear may result in high costs. Nevertheless, this cost can be considered a one-time investment, and critical components such as the rotor and stator can be manufactured using cost-efficient materials as single-use components.

The development of these new concepts and the conceptualization of the inner gear-actuated arrangement have implications beyond the scope of this study. These innovations can potentially improve the efficiency and the usage area of PCP systems, which could have broad

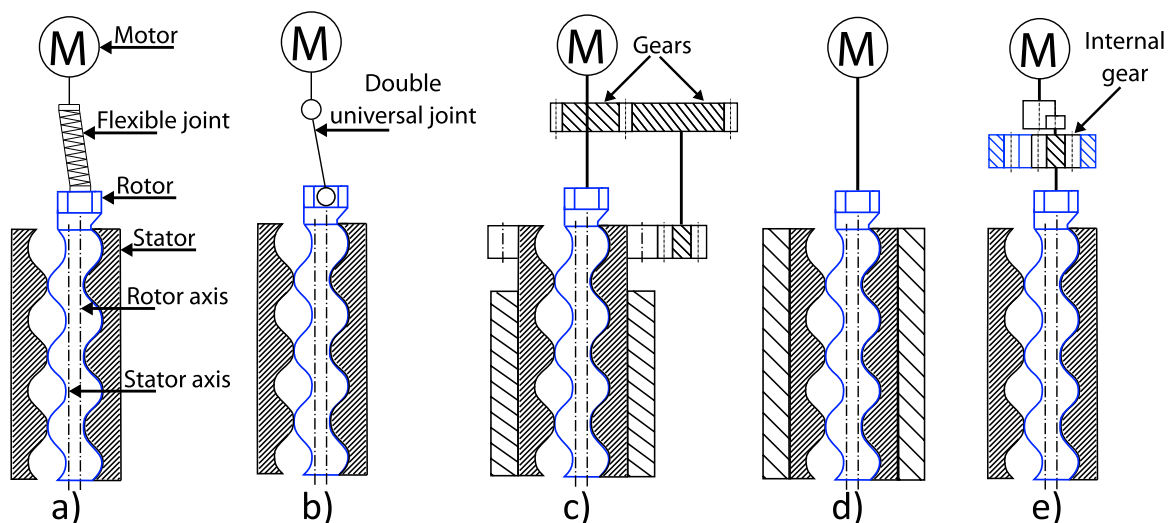

Fig. 13. Design layouts of possible PCP drive arrangements, namely a) conventional dispensing PCP, b) redesigned PCP, c) synchronised actuated PCP, d) inner gear-actuated PCP, and e) internal gear-driven PCP.

applications in industries such as pharmaceuticals, food processing, and bioprinting. In particular, the inner gear-actuated arrangement has the potential to revolutionize the field of bioprinting by enabling the use of a wider range of materials and providing a disposable solution. Further research and development are needed to realize the potential of these concepts fully, but they represent a promising direction for future work in the field of PCP design.

Conclusion

The purpose of this study was to develop a progressive cavity pump (PCP) concept for extrusion-based bioprinting (EBB) applications. Therefore, a spiral development process was used to achieve a novel PCP with the help of additive manufacturing (AM) and the application programming interface (API), which eases quick design iterations. PCP requirements were determined through literature research, a user questionnaire, user interviews and redesigning of a conventional PCP. Subsequently, three PCP concepts were designed, prototyped and evaluated to meet the defined requirements, and the final concept was approved for the product evaluation phase. Consequently, evaluation of the inner gear-actuated PCP was conducted to test the capability to produce in three dimensions, a common method in AM research. In addition, PCP design layouts were presented to show conceptualised and proposed drive arrangements.

Several studies have reported future works to develop an open-source PCP to decrease costs and adapt the technology for multi-material 3D printing [6,9,12]. This work makes several notable contributions to the existing knowledge in the literature, including the working mechanisms of PCPs and the design thinking to adapt PCPs for bioprinters. Consequently, this study provides the first comprehensive assessment of the working mechanism of PCPs to use in EBB applications and pave the way for the future development of PCPs.

While this study presents a promising design for a 3D-printed PCP, it is important to acknowledge its limitations and identify opportunities for future research. One of the main limitations of this study was the accuracy and precision of the developed pump. While the pump was designed to achieve a high degree of accuracy and precision, the 0.2 mm accuracy of the FFF prototyping method limited the ability to fully validate the design. Therefore, future research should consider using precision manufacturing methods to fabricate and test the pump to see the full potential of the final concept.

In addition, further studies are required to validate the extrusion accuracy and precision of the inner gear-actuated concept. One possible approach would be to conduct flow rate measurement experiments to compare the performance of the 3D-printed PCP to that of commercial ones. Another approach would be to conduct line printing experiments to determine the quality and consistency of the printed lines. These experiments would help to establish the reliability and performance of the developed pump and provide insights into its potential applications.

Overall, while this study represents an important step in the development of PCP mechanisms, additional research is needed to validate and refine the design. By addressing these limitations and exploring future opportunities for research, researchers can further advance the field of 3D printing and its applications in various industries.

CRedit authorship contribution statement

Yusuf Furkan Ugurluoglu: Conceptualization, Investigation, Methodology, Software, Validation, Visualization, Roles/Writing - original draft. **Ana Ferreira-Duarte:** Supervision, Writing - review & editing. **Piериgiorio Gentile:** Supervision, Writing - review & editing. **Javier Munguia:** Conceptualization, Supervision, Writing - review & editing.

Declaration of Competing Interest

The authors declare that they have no known competing financial interests or personal relationships that could have appeared to influence the work reported in this paper.

Acknowledgement

This research was funded by the Turkish Ministry of National Education.

References

- [1] ISO/ASTM (International Organization for Standardization/American Society for Testing and Materials), Additive manufacturing – General principles – Terminology, ISO/ASTM 52900:2015 ed., 2015.
- [2] Li, J., Chen, M., Fan, X., Zhou, H., 2016, Recent Advances in Bioprinting Techniques: Approaches, Applications and Future Prospects. *Journal of Translational Medicine*, 14:1–15.
- [3] Murphy, S.V., Skardal, A., Atala, A., 2013, Evaluation of Hydrogels for Bioprinting Applications. *Journal of Biomedical Materials Research Part A*, 101:272–284.
- [4] He, Y., Yang, F., Zhao, H., Gao, Q., Xia, B., Fu, J., 2016, Research on the Printability of Hydrogels in 3D Bioprinting. *Scientific Reports*, 6:1–13.
- [5] Ozbolat, I.T., Hospodiuk, M., 2016, Current Advances and Future Perspectives in Extrusion-based Bioprinting. *Biomaterials*, 76:321–343.
- [6] Fisch, P., Holub, M., Zenobi-Wong, M., 2020, Improved Accuracy and Precision of Bioprinting Through Progressive Cavity Pump-controlled Extrusion. *Biofabrication*, 13:015012.
- [7] Li, W., Ghazanfari, A., Leu, M.C., Landers, R.G., 2017, Extrusion-on-demand Methods for High Solids Loading Ceramic Paste in Freeform Extrusion Fabrication. *Virtual and Physical Prototyping*, 12:193–205.
- [8] Pusch, K., Hinton, T.J., Feinberg, A.W., 2018, Large Volume Syringe Pump Extruder for Desktop 3D Printers. *HardwareX*, 3:49–61.
- [9] G. Wang, L. Yao, W. Wang, J. Ou, C.-Y. Cheng, H. Ishii, xprint: A Modularized Liquid Printer for Smart Materials Deposition, 2016.
- [10] R. Moineau, A new capsulism, Ph.D. thesis, Doctoral Thesis. The University of Paris, 1930.
- [11] Shakor, P., Nejadi, S., Paul, G., 2019, A Study Into the Effect of Different Nozzles Shapes and Fibre-reinforcement in 3D Printed Mortar. *Materials*, 12:1708.
- [12] Yao, L., Ou, J., Wang, G., Cheng, C.-Y., Wang, W., Steiner, H., Ishii, H., 2015, Bioprint: A Liquid Deposition Printing System for Natural Actuators. *3D Printing and Additive Manufacturing*, 2:168–179.
- [13] Raval, A.D., Patel, C., 2022, Estimation of Interface Friction and Concrete Boundary Layer for 3D Printable Concrete Pumping. *Materials Today: Proceedings*, 57:664–669.
- [14] Canessa, E., Baruzzo, M., Fonda, C., 2017, Study of Moineau-based Pumps for the Volumetric Extrusion of Pellets. *Additive Manufacturing*, 17:143–150.
- [15] M.K. Gelber, Precision Hot-melt Freeform 3d Printing for Monolithic Multilayer Microfluidics, 2015.
- [16] Verbruggen, D., 2014, The Road to Better Paste Extrusion. *RepRap Magazine*, 3:26–29.
- [17] Yeh, Y.C., Yamada, N., Watanabe, Y., Shiblee, M.N.I., Ogawa, J., Khosla, A., Kawakami, M., Akamatsu, T., Furukawa, H., 2020, (invited) 3D Printing of Soft-matter Mono Pump in Infant Ventricular Assist Device (VAD) for Blood Pumping. *ECS Transactions*, 98:31–38.
- [18] ViscoTec Pumpen- u. Dosiertechnik GmbH, 3D Bioprinting with Alginate, adhesion ADHESIVES + SEALANTS 19 (2022)28–29.
- [19] H. Ojama, Visco bio-tulostuspään käyttöönotto ja testaus, 2022. (<https://urn.fi/URN:NBN:fi:amk-2022061518027>).
- [20] Boehm, B.W., 1988, A Spiral Model of Software Development and Enhancement. *Computer*, 21:61–72.
- [21] Ullman, D., 2009, *The Mechanical Design Process*. McGraw Hill.
- [22] Yahyaabadi, A., Driedger, M., Turenne, N., Connell, S., Parthasarathy, V., Carvey, A., Platero, V., Campos, J., Rososhansky, M., Ferguson, P., 2020, ManitoBasat-1: A Novel Approach for Technology Advancement. *IEEE potentials*, 39:17–23.
- [23] Pradel, P., Campbell, R.I., Bibb, R., 2019, When Design Never Ends - A Future Scenario for Product Development. in: *Proceedings of the Design Society: International Conference on Engineering Design*, 1:829–838.
- [24] P. Simontacchi, R. Blasi, E. Edeline, S. Sagnier, N. Ravier, A. Espinosa-Ramos, J. Breteau, P. Altenhoefer, Prometheus: Precursor of New Low-cost Rocket Engine Family, 2019.
- [25] Ulrich, K., Eppinger, S., 2011, *Product Design and Development*. McGraw Hill.
- [26] Nguyen, T., Al-Safran, E., Saasen, A., Nes, O.-M., 2014, Modeling the Design and Performance of Progressing Cavity Pump Using 3-D Vector Approach. *Journal of Petroleum Science and Engineering*, 122:180–186.
- [27] Gravesen, J., 2008, The Geometry of the Moineau Pump. *Computer Aided Geometric Design*, 25:792–800.
- [28] N. Aage, J. Donaldson, Y. Feng, G. Y. H. Grann, J. Gravesen, A. Hlod, T. Steenstrup, A.A. Larsen, K. Malakpoor, S. Markvorsen, D. Moreno, *Mathematical Problems for Moineau Pumps*(2006).

- [29] Autodesk, Moineau | Fusion 360 | Autodesk App Store, (accessed: 17.08.2022),2022 (<https://apps.autodesk.com/FUSION/en/Detail/Index?id=307627708314337150&appLang=en&os=Win64>).
- [30] Paxton, N., Smolan, W., Böck, T., Melchels, F., Groll, J., Jungst, T., 2017, Proposal to Assess Printability of Bioinks for Extrusion-based Bioprinting and Evaluation of Rheological Properties Governing Bioprintability. *Biofabrication*, 9:044107.
- [31] Park, E.-K., Song, K.-W., 2010, Rheological Evaluation of Petroleum Jelly as a Base Material in Ointment and Cream Formulations: Steady Shear Flow Behavior. *Archives of Pharmacal Research*, 33:141–150.
- [32] Nordson, How does a progressive cavity pump work? 2020.(https://www.youtube.com/watch?v=ph588_XhceU), available at <https://tinyurl.com/mvz537x4> (Accessed: 23 January 2022).
- [33] Nguyen, T., 2020, *Artificial Lift Methods: Design, Practices, and Applications*. Springer Nature.
- [34] 3D-Benchy, About, 2016.(<https://www.3dbenchy.com/about/>), available at <http://www.3dbenchy.com/about/> (Accessed: 20 June 2021).