

PAWLAK-ANDRYSZCZYK, Żaneta, ANDRYSZCZYK, Marek, TOPOLIŃSKI, Tomasz & SOBIESKA, Magdalena. Analysis of upper and lower limb movement in infants in response to optic flow - preliminary research. *Journal of Education, Health and Sport*. 2023;13(1):178-187. eISSN 2391-8306. DOI <http://dx.doi.org/10.12775/JEHS.2023.13.01.027>  
<https://apcz.umk.pl/JEHS/article/view/40779>  
<https://zenodo.org/record/7380230>

The journal has had 40 points in Ministry of Education and Science of Poland parametric evaluation. Annex to the announcement of the Minister of Education and Science of December 21, 2021. No. 32343.  
Has a Journal's Unique Identifier: 201159. Scientific disciplines assigned: Physical Culture Sciences (Field of Medical sciences and health sciences); Health Sciences (Field of Medical Sciences and Health Sciences).  
Punkty Ministerialne z 2019 - aktualny rok 40 punktów. Załącznik do komunikatu Ministra Edukacji i Nauki z dnia 21 grudnia 2021 r. Lp. 32343. Posiada Unikatowy Identyfikator Czasopisma: 201159.  
Przypisane dyscypliny naukowe: Nauki o kulturze fizycznej (Dziedzina nauk medycznych i nauk o zdrowiu); Nauki o zdrowiu (Dziedzina nauk medycznych i nauk o zdrowiu).  
© The Authors 2022;  
This article is published with open access at Licensee Open Journal Systems of Nicolaus Copernicus University in Torun, Poland  
Open Access. This article is distributed under the terms of the Creative Commons Attribution Noncommercial License which permits any noncommercial use, distribution, and reproduction in any medium, provided the original author (s) and source are credited. This is an open access article licensed under the terms of the Creative Commons Attribution Non commercial license Share alike. (<http://creativecommons.org/licenses/by-nc-sa/4.0/>) which permits unrestricted, non commercial use, distribution and reproduction in any medium, provided the work is properly cited.  
The authors declare that there is no conflict of interests regarding the publication of this paper.  
Received: 06.11.2022. Revised: 20.11.2022. Accepted: 30.11.2022.

## Analysis of upper and lower limb movement in infants in response to optic flow - preliminary research

Żaneta Pawlak-Andryszczyk<sup>1</sup>, Marek Andryszczyk<sup>2</sup>; Tomasz Topoliński<sup>3</sup>, Magdalena Sobieska<sup>4</sup>

<sup>1</sup> Department of Physiotherapy, Chair for Physiotherapy and Rehabilitation, Poznań University of Medical Sciences, Poland | <https://orcid.org/0000-0003-3889-7573> | [ze.pawlak@gmail.com](mailto:ze.pawlak@gmail.com)

<sup>2</sup> Faculty of Mechanical Engineering, Bydgoszcz University of Science and Technology, Poland | <https://orcid.org/0000-0003-2732-8631> | [andryszczyk.marek@gmail.com](mailto:andryszczyk.marek@gmail.com)

<sup>3</sup> Faculty of Mechanical Engineering, Bydgoszcz University of Science and Technology, Poland | <https://orcid.org/0000-0002-6232-2692> | [tomasz.topolinski@pbs.edu.pl](mailto:tomasz.topolinski@pbs.edu.pl)

<sup>4</sup> Department of Physiotherapy, Chair for Physiotherapy and Rehabilitation, Poznań University of Medical Sciences, Poland | <https://orcid.org/0000-0001-5341-8708> | [msobieska@ump.edu.pl](mailto:msobieska@ump.edu.pl)

Corresponding author: [andryszczyk.marek@gmail.com](mailto:andryszczyk.marek@gmail.com)

### ABSTRACT

Introduction: optic flow is studied in many scientific areas such as automation, robotics, biomechanics and neuropsychology. People who are not visually impaired use this mechanism to move around, usually without realising its complexity. It consists of information provided by the sense of sight and analysed in the central nervous system about the speed and direction of a moving object and the direction and amplitude of the angular and linear components of one's body. However, little is known about how this mechanism develops in the young child.

Objective: Observation of upper and lower limb movement in infants between 4 and 12 weeks of age under the influence of optic flow stimulation as a stimulus. Development of an optimal test protocol and adaptation of the author's research station.

Material and method: 16 infants aged from 4 to 12 weeks were initially invited to the study, of which 14 infants were finally included in the study group. The motor response test consisted of two stages. Stage I (static trial): the stimulus was a stationary black and white chessboard pattern; stage II (dynamic trial): the chessboard pattern moved toward the child at a speed of 0.17m/s. Cameras recorded the test in both stages.

Results: the children showed increased limb movement under the influence of optical flow (test stage II: dynamic test) compared to stimulation with a fixed pattern (test stage I: static test).

Conclusions: a response to dynamic versus static stimuli was observed in 11 of 14 children, but testing in one-month-olds is unreliable due to poor head control.

Keywords: rehabilitation; infants; optic flow; motion analysis; .

## 1. INTRODUCTION

The process of seeing consists of the reception of information in the form of electromagnetic waves from the visible light range on the retina of both eyeballs, then transferring this information to the appropriate areas of the cerebral cortex, where interpretation, memorising, and integration of this information with other stimuli takes place [6, 12].

The senses of touch, hearing, proprioception, taste and smell are intensively stimulated in the womb, unlike vision, which has no direct stimulation by light in foetal life. An intensive development only takes place after birth [21].

Most studies show that in a 12-month-old baby, the visual system reaches a normative visual acuity of 1.0 [19]. Consistency in seeing the size of an object with a change in distance develops by 10-11 years of age [24].

Our study focused on the vision of infants up to 3 months of age. The newborn has limited visual abilities when coming into the world. In this period, the density of cones located in the macular dome is 1/3 of the level of the fully developed eye [23].

In a 1-month-old infant, the corneal reflex, the reaction of the pupils to light, reflex closing or tightening of the eyelids in response to a sudden stimulus, are observed. Eyeball movement is uncoordinated; the child uses one eye and the other (visual acuity and focus). The baby prefers observing faces to observing toys. The visual field of the newborn baby is 20 degrees, and the visual acuity is 0.05-0.025. The baby prefers to observe moving images rather than static ones. Bilateral vision develops from 2 to 4 months of age (information from two eyes is presented in a single image), but this vision is not fully formed. With each passing week, the visual cortex develops new abilities. In the second and third months of life, the baby starts to observe his hands and can stare longer at another person's face. During this period, the vision is more coordinated, and the eyeballs start to move in unison [19].

One of the phenomena analysed concerning vision is optical flow. The observer's perception of the movement of objects can be understood as optical flow. This phenomenon can be observed when the motionless observer watches a moving object or when the observer is moving and registers objects that he passes. The observer receives information on the speed, direction and amplitude of the rotational and linear components of the body's position. This physical phenomenon is widely used in automation and robotics [11, 15, 16, 25].

It is worth noting that visual stimuli must be supplemented with information about one's body movement, from proprioception and the labyrinth.

Assessment of human movement and biomechanical modelling is part of the work of many scientists using many different methods and mathematical models [10, 13].

Early research in analysing movement in infants in response to optic flow dates to the 1970s. In most studies, contrasting large black and white patterns were chosen. The studies analysed the anteroposterior optic flow direction and whether significant differences in infants' responses were observed [11, 18].

In addition, the velocity of the flow presented to the children was studied. The literature mentions studies conducted at speeds between 0.01 and 0.27m/s [1, 2, 14]. Generally, in most studies, cameras recorded the changes in the children's locomotor system that occurred under the influence of the stimulus. The children were placed in pronation, standing or sitting positions, depending on their age [1, 3, 14].

Table 1 presents the parameters listed in earlier optical flow studies [20].

Tab. 1. Research parameters in previous literature

Examination conditions	Image speed	Geometry of image	Method of registration	Positioning of the test person	Age of children	number of children	Time of exposure
Art. [3]	0,17m/s	Chessboard, windmill	cameras	pronation at an angle of 45 from the vertical	3days	48	-
Art. [1]	0,27m/s	-	cameras	pronation	6-12 months	33	6x60s
Art. [4]	0,17m/s	Chessboard,	cameras	pronation at an angle of 45 from the vertical	Two months	22	4x60s
Art. [14]	0,01-0,12 m/s	-	-	sitting in a car seat	One month	25	
Art. [8]	0,12m/s	Chessboard,	cameras	pronation	Three days	26	3x60s
Art. [17]	-	--	cameras	standing	2-5 months 7-9 months	24	

There are no reports of observations of motor development in children subjected to early optical flow response testing in the articles reviewed above. These findings might be used to predict motor development or could provide, for some children, an early warning signal of developmental disorders.

The study presented in this article aimed to develop a reproducible method to assess the effect of an optical flow stimulus on a child's kinematic response (upper and lower limb movement in infants between 4 and 12 weeks of age).

## 2. MATERIAL AND METHODS

### 2.1. Inclusion and Exclusion Criteria

The Bioethics Committee of Karol Marcinkowski Medical University in Poznan approved the following study.

Sixteen infants were invited to the study; two were excluded from the study based on exclusion/inclusion criteria after taking a medical history.

The exclusion criteria were characterised into three categories. Category one was related to aspects of the course of pregnancy and delivery, category two to developmental/genetic diseases, and category three was due to abnormalities of positioning responses.

Category one included delivery before 37 weeks gestation, and the newborn's APGAR score was below 8 points at the time of delivery. Category two looked for aspects of genetic and metabolic diseases, developmental disorders, visual disturbances, and suspected epilepsy. In exclusion category three, the abnormalities of positioning reactions were mainly low muscle tone and abnormal head position (torticollis) assessed on the day of the study by a physiotherapist using the HINE questionnaire.

Finally, 14 infants aged 1 or 2 months were included in the study, whose APGAR score was 10. This group included seven children aged 4 to 8 weeks (three girls and four boys) and seven aged from 8 to 12 weeks (four girls and three boys). The average birth weight of all children was  $3900 \pm 512$  grams with a standard deviation of 512 grams. Among boys, the results are slightly higher at  $3911 \pm 358$  grams compared to girls, whose mean birth weight was slightly lower, but there was more significant variability in results ( $3887 \pm 690$  grams) (Table 2)

Tab. 2 Child birth weight results

Birth weight of infants	N	AV	SD	Me
All children	14	3900	512	3930
Boys	7	3911	358	3780
Girls	7	3887	690	4005

At the time of the survey, the children's weights ranged from the 25th percentile to the 75th percentile and were defined as normative for the child's age.

### 2.2. Protocol

The following figure (Fig. 1) shows the inclusion process in the study and how the study children were assessed [5, 9].

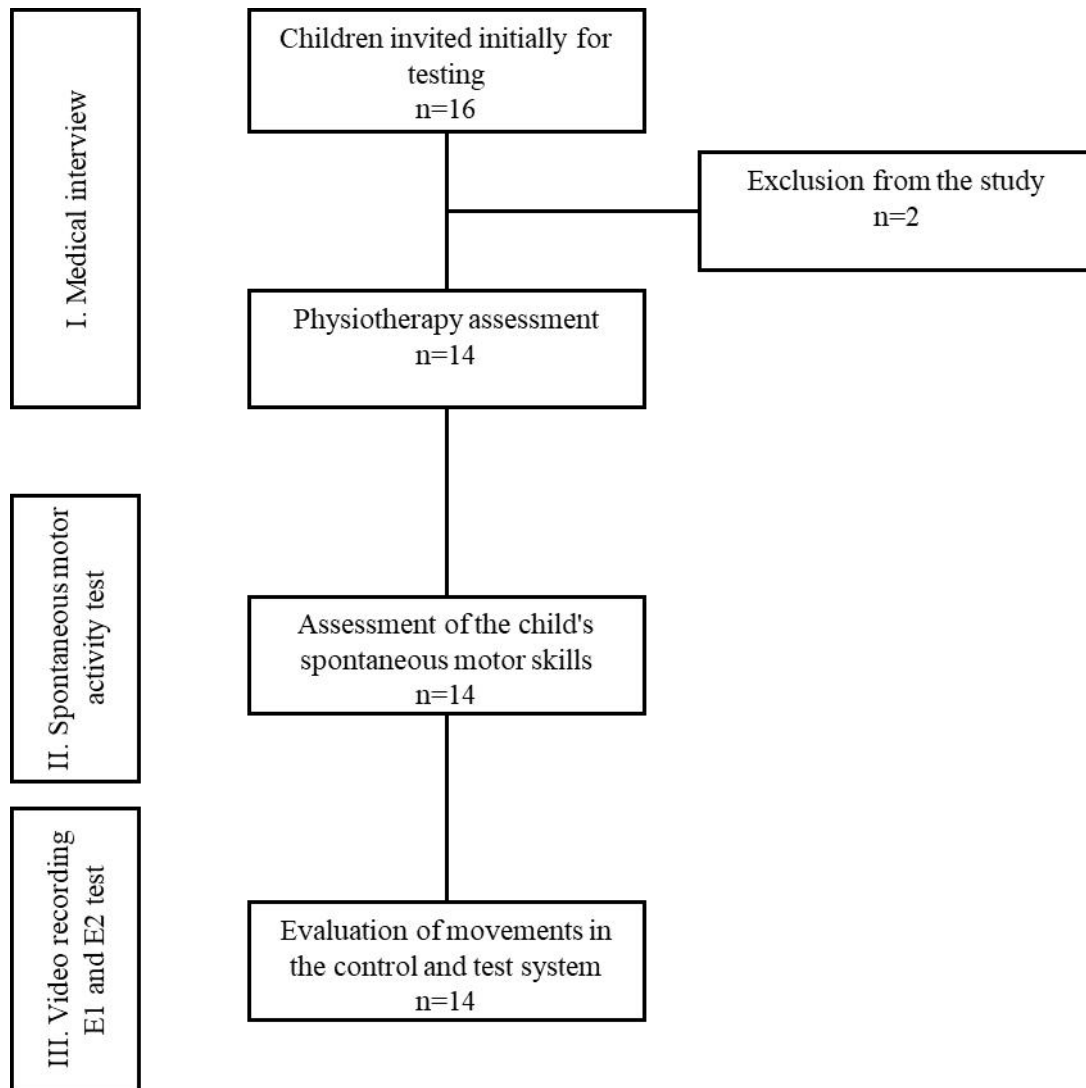

Fig. 1. Procedure for recruiting children to the study and how the study will be conducted

### 3. METHODS

The qualification process for the study and the study itself consisted of 3 parts:

I. Medical interview: based on the questions asked to the parents/guardians of the child and the data contained in the medical records, information was collected about the course of pregnancy and delivery, the child's birth weight, APGAR score and early child development. The APGAR scale is used to assess the newborn's condition after birth, named after the author who created the scale [7]. The baby's breathing, heart function, muscle tone, reflex response and skin colour are assessed. The maximum score is 10 points, 0-2 for each parameter.

II. Examination of spontaneous motor skills in supination and pronation positions: tests were applied using the standardised Hammersmith Infant Neurological Examination questionnaire (HINE), a standardised clinical neurological examination that can be used to assess the development of infants up to 24 months). The abnormal muscle tone scores were the reason for excluding two children from the study.

III. Video specific test recording of children's motor response to visual flow in two stages::

E1: static checkerboard pattern,

E2: dynamically moving toward the child, the pattern of the same chessboard

#### 3.1. The conduct of a proper study

The researcher held the children during the test in a pronated position over a table with a translucent top on which a chessboard image was projected from underneath.

Two ways of gripping the children were used, depending on the head control and postural response of the child in the pronation position:

- the first way of gripping for unstable children: the children rested on the therapist's hand with their chest and abdomen, and the child's head was supported under the chin for better stabilisation; the therapist's other hand stabilised the child's side. All children aged 4 to 8 weeks required this grip (Fig. 2).

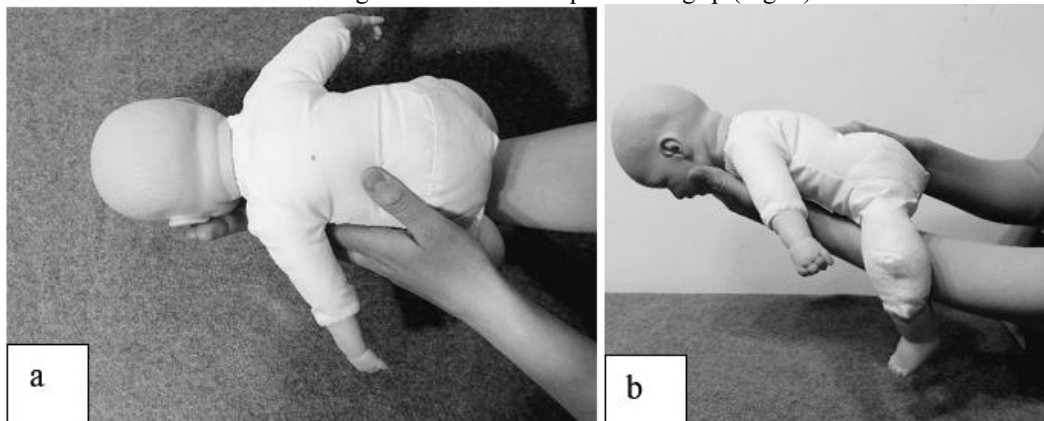

Fig 2. Grip for children with poor head stability/control a) top view b) side view

- A second way of grasping for more stable children: children with better head control were grasped under the chest so as not to restrict the children's arm movements, and the therapist's other hand grasped the child by the pelvic bone. This way was used with good head control (Fig. 3).

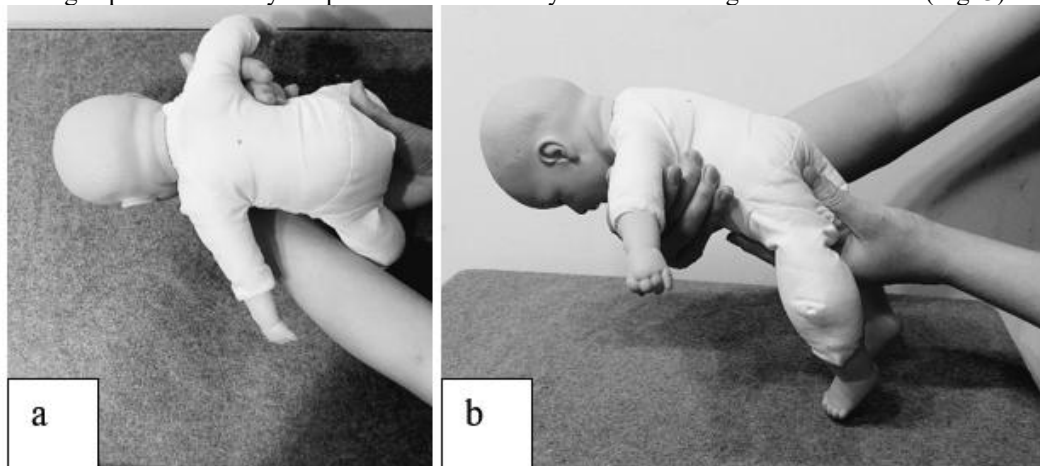

Fig 3. Grip for children with standard head stabilisation/control a) top view b) side view

At the end of the study, the videos obtained from the two screenings were analysed. The child's motor response in response to a stimulus in the form of a stable image and then a moving image was compared.

### 3.2. The position:

The author's stand (Fig. 4) was used for the study, which was developed from previous optical flow studies. However, our modifications were made. The table in the study presented here had a semi-transparent top so that the image projected from below was visible. In Marianne Barbu-Roth's study, the table had a mirror in which the image from the projector was reflected onto the tabletop. Geometrical parameters such as the width and length of the table are not the same as in other studies. The tabletop height was adapted to the height of the person who tested the children.

The own test station consisted of:

- An overhead projector projecting a chessboard image onto a translucent table top.
- a PC controlling the settings of the displayed image;
- a table with the following dimensions: height 1.2m, length 1.5m and width 0.7m, with a semi-transparent top, constituting a screen for displaying the image of the chessboard
- GoPro Hero8 cameras for video recording were positioned perpendicular to each other over the tabletop;
- a mirror placed opposite the investigator to observe the child's reaction.
- A black and white chessboard with a field size of 7 by 10 cm (projected from underneath by a projector) was used to present the optical flow. In the dynamic system, the speed of movement of

the chessboard was 0.17m/s.

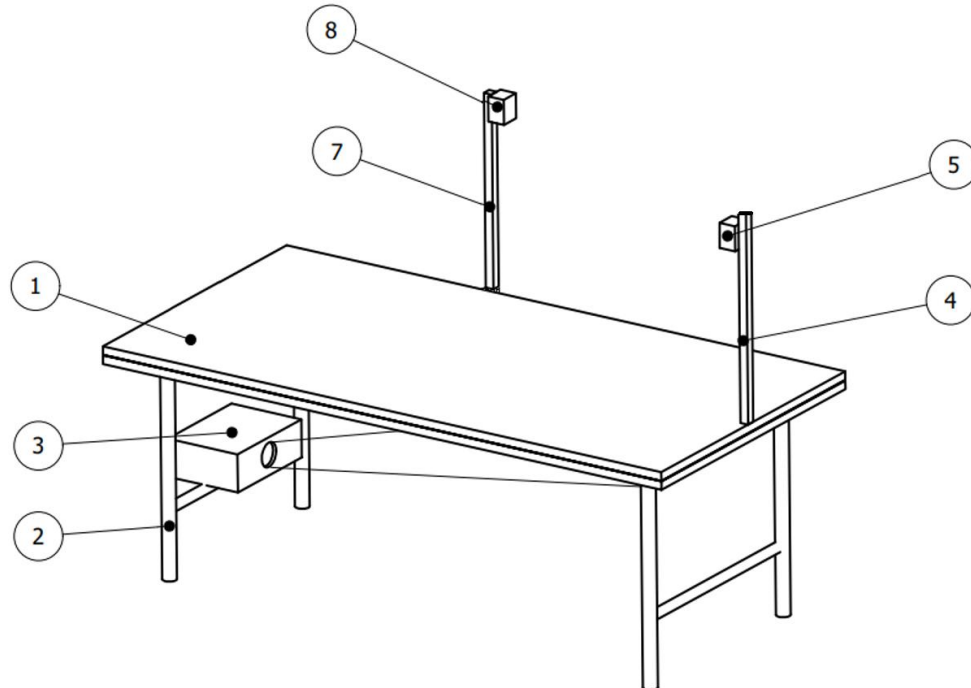

Fig 4. Optical flow test bench: 1) translucent top, 2) legs, 3) projector projecting an image onto the translucent top, 4) and 7) camera stands, 5) and 8) cameras

All parts of the study took place in the presence of a parent/guardian.

The parameters that were taken from the literature concerned the chessboard's image and the chessboard's speed of movement at 0.17m/s, as these were the parameters most commonly used in previous publications.

The author's modifications that were applied during the study concerned:

- testing on children aged 1 and 2 months;
- how the child was held by the person conducting the study and the choice of grasp according to the child's degree of head position control;
- the use of a semi-transparent top, which allows a direct display of the image while eliminating excessive glare and reflection from the surface
- exposure of the child to the stimulus of 20 seconds.

Currently, there is no standard or standardisation for conducting optical flow-induced child movement studies.

### 3.3. Assessment of movement in children

Noraxon MYOVideo (US) software version 3.8 was used to assess movement under an academic licence. Each measurement was performed separately with two cameras, according to the schematic diagram of the presented workstation. The parameter analysed was the count of flexion and straightening movements of the upper and lower limbs.

The motion assessment was 20 seconds of video viewed from two cameras. The movement was observed in real-time and dual acceleration mode. When assessing movement in accelerated mode, a corresponding sequence of alternating movements of the upper and lower limbs, resembling a crawling movement, was noted; this sequence was called a 'cycle'. Tables with the results were created for the age groups of one- and two-month-old children, respectively.

Statistical analysis of the results was performed using the Statistica 13 programme. Due to the nature of the variables, the results were compared using the Wilcoxon test, and a value of  $p < 0.05$  was taken as a significant difference.

## 4. RESULTS

Observing the child in the accelerated video made it possible to notice that in some children, a motor repertoire resembled a cycle (a cycle understood as alternating movements of the upper and lower limbs in the correct order). In the case of one-month-old children, five showed a 1 to 3-fold increase in the number of cycles

during the presentation of a moving picture compared to a static picture. In the study group of two-month-old children, such a reaction was observed in two children.

For each child, the occurrence of movements was counted for the upper and lower limbs of the left and right sides of the body.

An example of the left upper limb assessment results is shown below (Fig. 5).



Fig 5. Example of left upper limb assessment results

The results in Table 3 show the median and quartile results (Q1-Q3) for the number of movements of the right and left upper limbs and right and left lower limbs. In addition, the number of head movements (side-to-side movement) and 'cycle' like alternating limb movements are presented. The results showed, in each case, a significant increase in movements after the presentation of a motor stimulus relative to a static stimulus. For the right upper limb, the initial results were 1 (1-1.75) vs 2 (2-2) after stimulus presentation ( $p=0.009$ ). Slightly more significant differences were obtained for the number of movements of the left upper limb, where scores changed from 1 (1-1.75) to 2.5 (2-3.75) ( $p=0.005$ ).

The results for the lower limbs indicated a minor change, where for the right side, the results change from 1 (1-2) to 2 (2-3) ( $p=0.034$ ), and for the left side, the change is 1 (1-1.75) vs 2 (2-3.75) ( $p=0.012$ ).

The number of cycles performed at the static stimulus was 0 (0-1) vs 1 (0.25-2) during the moving stimulus ( $p=0.012$ ).

Head movements at the static stimulus were almost non-existent, giving an initial score of 0 vs 1 (0-1) during the moving stimulus display ( $p=0.023$ ).

Tab. 3. Comparisons of the number of movements after the presentation of a moving versus a static stimulus

number of moves	Test E1			Test E2			Test result	Value p
	Me	Q1	Q3	Me	Q1	Q3		
Limb upper right	1	1	1,75	2	2	2	2,606	<b>0,009</b>
Limb upper left	1	1	1,75	2,5	2	3,75	2,796	<b>0,005</b>
Limb lower right	1	1	2	2	2	3	2,121	<b>0,034</b>
Limb lower left	1	1	1,75	2	2	3,75	2,516	<b>0,012</b>
Cycle	0	0	1	1	0,25	2	2,513	<b>0,012</b>
Head	0	0	0	1	0	1	2,267	<b>0,023</b>

In summary, among the fourteen infants studied, an enhanced response was observed in eleven infants after the presentation of a moving stimulus (E2 - image of a moving chessboard) compared to a static one (E1 - an image of a stationary chessboard). It should be noted, however, that the resulting intensification is observed to a greater extent in the upper limbs than in the lower limbs.

The study did not analyse the effect of the anthropometric characteristics of the children due to the occurrence of a strongly homogeneous, healthy/regular group of children in terms of the above parameters, as well as having a normal state of psycho-motor development for this age.

## 5. DISCUSSION

As in most literature studies, a black and white pattern was used, which is evident for 1- and 2-month-old children [2-4, 8].

During the study, enhanced motor response to a moving pattern was observed in 11 out of 14 children, compared to a response to a static pattern. In other studies, researchers have also observed an enhanced response of children to an optical flow stimulus. Additionally, Marianne Barbu -Roth's study observed that the right upper limb and the left lower limb moved more frequently. However, no such relationship was observed in our study. This response is not clearly explained by the researchers [3]. Some suggest that this may already be the beginning of the lateralisation process; others that right-handed asymmetry is more common in infants (the right hand initiates global movement [8]).

In the authors' study, definite differences were observed in the methodology of testing 1- and 2-month-old children. In 1-month-old babies, it was necessary to use a grip with the head supported by the hand, under the chin. During this hold, it was observed that the babies turned their heads towards the tactile stimulation on the cheek, and a searching (sucking) reflex was triggered. Therefore, a tactile stimulus can independently trigger or intensify the response to a visual stimulus, which changes the study's outcome. The method of gripping the babies in Marianne Barbu -Roth's study differed: 3-day-old babies were gripped under the chest and pelvic bone, but at a 45-degree angle from vertical, without their feet resting on the ground. [1, 3]. In our opinion, this precludes a child with significant flaccidity from being correctly positioned during the study. Additionally, from a practical point of view, children with a lower antigravity response in the assessment of spontaneous motor skills presented a lower motor response during visual flow than children with a rich motor repertoire. This suggests the need for an initial assessment of the child's motor development by participating in the optical flow response tests.

Most likely, the difference between one- and two-month-old children may be because two-month-old children could keep their heads in the body midline during the test, resulting from greater muscle strength of the cervical spine. It also cannot be ruled out that the motor response in one-month-olds is related more to the refinement of visual function and not strictly to motor skills.

The publication brings up another aspect: the weight of the child's body as a limiting factor for the child's ability to perform the movement. Studies [1, 22] mentioned that the stepping reflex might not be apparent at two months of age due to the lack of proportionality of lower limb mass and muscle strength at this stage of life for the child to move the force of gravity. It remains to be discussed whether such data should be included in subsequent studies.

Another observation is that flaccid babies have a slower/less intense motor response to optic flow, which may be partly explained by low muscle strength.

It is worth noting that the study is preliminary, and based on the results obtained, further attempts will be made to optimise the influence of the visual stimulus while minimising the influence of other factors on the motor response in children.

It might be interesting to see the reaction if only a white background were used (simple stimulus, no static chessboard pattern) against an image of a still or moving chessboard. Such a modification will exclude the effect of the child's intention to grasp, triggered by the complex graphic stimulus.

The above modifications will make it possible to determine more precisely which of the elements of the optical stimulus (shape, movement, speed) may have the most decisive influence on the appearance of a motor response.

On the side of the research object:

- the proportion of older children (two months old), developing typically.
- the proportion of children with neurological deficits.

The above factors are intended to provide an opportunity to assess the motor component in response to optic flow and, at the same time to assess whether overt neurological motor deficits cause a change in response to an optical stimulus.

The proposal to apply such modifications makes the test results as reliable as possible. The assessment of reactions to optical stimuli can be included in the broadly understood range of screening tests used to exclude abnormal movement patterns or detect early developmental abnormalities.

A further stage of the study will be to refine the research method based on the conclusions drawn regarding the methodology and the quantitative assessment of joint movement (changes in joint range of motion).



## 6. CONCLUSIONS

The conclusions that can be drawn directly from the results obtained from work below are:

1. During the study, increased motor response to a moving pattern was observed in 11 out of 14 children compared to the response to a static pattern.
2. When testing the effect of a visual stimulus, children should present reasonable control of head posture.

Additional conclusions that follow from the study in terms of the survey methodology are that possible elements that may be modified when conducting further research could be:

In terms of methodology:

- an arrangement of four cameras analysing each limb separately for a detailed evaluation of the results;
- changing the geometry of the displayed pattern
- changing the speed of the displayed pattern;
- the randomised sequence of static and dynamic testing.

## 7. REFERENCES

1. ANDERSON D.I., KOBAYASHI Y., HAMEL K., RIVERA M., CAMPOS J.J., BARBU-ROTH M., *Effects of support surface and optic flow on step-like movements in pre-crawling and crawling infants*. Infant Behavior and Development, 2016, 42, 104-110. DOI: <https://doi.org/10.1016/j.infbeh.2015.11.005>.
2. BARBU-ROTH M., ANDERSON D.I., DESPRÈS A., STREETER R.J., CABROL D., TRUJILLO M., CAMPOS J.J., PROVASI J., *Air stepping in response to optic flows that move Toward and Away from the neonate*. Dev Psychobiol, 2014, 56(5), 1142-1149. DOI: 10.1002/dev.21174.
3. BARBU-ROTH M., ANDERSON D.I., DESPRES A., PROVASI J., CABROL D., CAMPOS J.J., *Neonatal stepping in relation to terrestrial optic flow*. Child Dev, 2009, 80(1), 8-14. DOI: 10.1111/j.1467-8624.2008.01241.x.
4. BARBU-ROTH M., ANDERSON D.I., STREETER R.J., COMBROUZE M., PARK J., SCHULTZ B., CAMPOS J.J., GOFFINET F., PROVASI J., *Why does infant stepping disappear and can it be stimulated by optic flow?* Child Dev, 2015, 86(2), 441-455. DOI: 10.1111/cdev.12305.
5. CUSCHIERI S., *The STROBE guidelines*. Saudi J Anaesth, 2019, 13(Suppl 1), S31-S34. DOI: 10.4103/sja.SJA\_543\_18.
6. EDWARD D.P., KAUFMAN L.M., *Anatomy, development, and physiology of the visual system*. Pediatric Clinics of North America, 2003, 50(1), 1-23. DOI: [https://doi.org/10.1016/S0031-3955\(02\)00132-3](https://doi.org/10.1016/S0031-3955(02)00132-3).
7. FLORCZYK W., WEBER-NOWAKOWSKA K., GĘBSKA M., *The influence of thyroid function disorders on pregnant women on the Apgar scale and psychomotor development of the child in the first 18 months of life*. Journal of Education, Health and Sport, 2020, 10(4), 99-112. DOI: 10.12775/JEHS.2020.10.04.012.
8. FORMA V., ANDERSON D.I., GOFFINET F., BARBU-ROTH M., *Effect of optic flows on newborn crawling*. Dev Psychobiol, 2018, 60(5), 497-510. DOI: 10.1002/dev.21634.
9. FREEMANTLE N., GRILLI R., GRIMSHAW J., OXMAN A., *Implementing findings of medical research: the Cochrane Collaboration on Effective Professional Practice*. Qual Health Care, 1995, 4(1), 45-47. DOI: 10.1136/qshc.4.1.45.
10. GASTALDI L., LISCO G., PASTORELLI S., *Evaluation of functional methods for human movement modelling*. Acta Bioeng Biomech, 2015, 17(4), 32-38.
11. Gibson J.J., *The perception of the visual world*. The perception of the visual world. 1950, Oxford, England: Houghton Mifflin. xii, 242-xii, 242.

12. HYJEK M., MARCZAK A., HORDEJUK M., SZYMKIEWICZ K., *Psychosomatics in ophthalmology - review of the literature*. Journal of Education, Health and Sport, 2022, 12(12), 30-34. DOI: 10.12775/JEHS.2022.12.12.004.
13. IWANSKA D., URBANIK C., *The sense of position and movement in the knee joint during voluntary movements*. Acta Bioeng Biomech, 2013, 15(3), 11-17.
14. JOUEN F., LEPECQ J.-C., GAPENNE O., BERTENTHAL B.I., *Optic flow sensitivity in neonates*. Infant Behavior and Development, 2000, 23(3), 271-284. DOI: [https://doi.org/10.1016/S0163-6383\(01\)00044-3](https://doi.org/10.1016/S0163-6383(01)00044-3).
15. LAPPE M., BREMMER F., VAN DEN BERG A.V., *Perception of self-motion from visual flow*. Trends Cogn Sci, 1999, 3(9), 329-336. DOI: 10.1016/s1364-6613(99)01364-9.
16. Lucia M. Vaina, Scott A. Beardsley, Rushton S.K., *Optic Flow and Beyond*. 2004: Springer Dordrecht.
17. MOERCHEN V.A., SAEED M.E., *Infant visual attention and step responsiveness to optic flow during treadmill stepping*. Infant Behavior and Development, 2012, 35(4), 711-718. DOI: <https://doi.org/10.1016/j.infbeh.2012.05.008>.
18. NÁÑEZ J., YONAS A., *Effects of luminance and texture motion on infant defensive reactions to optical collision*. Infant Behavior and Development, 1994, 17(2), 165-174. DOI: [https://doi.org/10.1016/0163-6383\(94\)90052-3](https://doi.org/10.1016/0163-6383(94)90052-3).
19. Pakuła B., *Seeing: processes and functions [in Polish]*. 2020, Kalisz: Akademia ćwiczyć oko.
20. PAWLAK-ANDRYSZCZYK Ż.E., ANDRYSZCZYK M., SOBIESKA M., *MOTOR REACTIONS OF INFANTS IN RESPONSE TO OPTICAL FLOW – LITERATURE REVIEW*. IRONS, 2021, 36, 6. DOI: 10.19271/IRONS-000141-2021-36.
21. POPA D.P., SAMSON M., *Reconsideration of the stages in the maturation of visual function in children*. Oftalmologia, 1995, 39(2), 119-124.
22. THELEN E., RIDLEY-JOHNSON R., FISHER D.M., *Shifting patterns of bilateral coordination and lateral dominance in the leg movements of young infants*. Dev Psychobiol, 1983, 16(1), 29-46. DOI: 10.1002/dev.420160105.
23. Topor I., Rosenblum L.P., Hatton D.D., *Visual conditions and functional vision early intervention issues*. 2004, Early Training Center for Infants and Toddlers With Visual Impairments: Chapel Hill, NC.
24. Vasta R., Maith M.M., Miller S.A., *Child psychology [in Polish]*. 1995, Warszawa: Wydawnictwa Szkolne i Pedagogiczne.
25. Wulff J., Sevilla-Lara L., Black M.J. *Optical flow in mostly rigid scenes*. in *Proceedings of the IEEE Conference on Computer Vision and Pattern Recognition*. 2017.