

Prediction of Strap Joint Design Margin in After Treatment System

Aniket M Pawar, Kishor P Deshmukh



Abstract: The automotive vehicle has an exhaust system, also known as the after treatment System. It consists of different components such as Diesel Oxidation catalysts (DOC), Diesel Particulate Filters (DPF), Selective Catalytic Reduction Systems (SCR), etc. These components are mounted in the chassis with the help of strap joints. The strap joints provide flexible and serviceable connections between ATS bodies and chassis. The strap joint assembly consists of a T bolt, trunnion, and nut with strap. As the nut tightened, the tension induced in the strap, which results in clamping the body. If the tension in the strap is not sufficient, it may cause the failure of the joint. The failure can be yielding of material, slipping, and separation of the body. The strap joint should be designed so that these kinds of failures can be avoided. This paper presents the work on the calculation of the design margin using analytical and FEA methods. The failure modes addressed in this paper are yielding of the strap joint due to applied preload on the T bolt, slipping, and separation of the ATS body from the strap due to the application of dynamic loads such as acceleration G loads in multiple directions. The acceleration load is calculated from the PSD profile. For calculating design margins from the FEA method, nonlinear analysis is performed, followed by PSD analysis to estimate the bracket reaction forces. These reaction forces are used to calculate slip and separation margins. The tests were performed under similar conditions on a shaker table, and the results from both analytical and FEA methods were correlated with test observations to validate the proposed method of calculation of strap joint design margin.

Keywords: After Treatment System, Design Margin, Hoop Stress, Strap Joint

I. INTRODUCTION

The automotive vehicle has an exhaust system that collects exhaust gases from the engine and guides them to a remote location. The several types of conduits, tubes, and hoses of various sizes and shapes are connected such that they form a path for exhaust gases. The exhaust system includes a manifold, muffler, catalytic converter, sensors, and resonators that remove harmful substances from exhaust gas, reduce noise levels, and discharge purified exhaust gases into the atmosphere. The exhaust system is also known as the after-treatment system. The band clamps are used for

connecting hoses, pipes, and tubes. By applying radial force, it provides a pressure seal between components [1]. Strap joints are like band clamps. Straps are used for mounting after-treatment systems on the chassis with the help of brackets. The strap joint provides a serviceable, adjustable, and flexible method of fastening the exhaust after treatment components to brackets. As the EGP is an integration of various components, it is required to mount it on a chassis, so straps have the main role of holding the whole weight of the system. The strap joint consists of flat straps, a T bolt, a trunnion, and a nut assembly. The number of straps depends on the layout of the after-treatment system. The working principle of the Strap Joint is illustrated in Figure 1. When the clamp nut is tightened, it results in an increase in tension in the straps, causing the application of radial forces on the component. This radial force induces friction between the strap and the component and provides the clamping action. But if the tension in the strap increases excessively, it results in the failure of the strap.

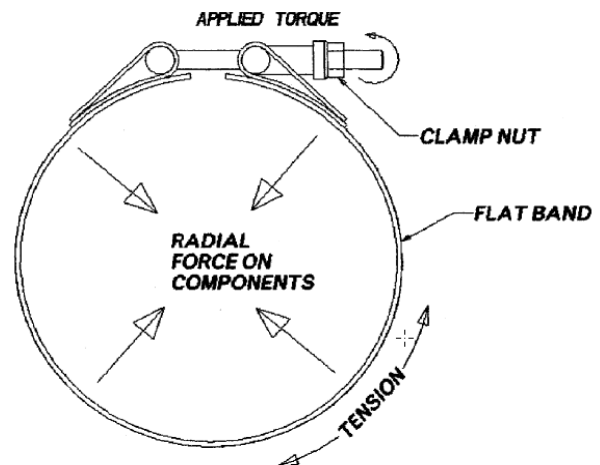

Figure 1. Working Principle of Strap Joint

There are various failures observed in the strap joint, including yielding of the strap due to assembly preload, plastic deformation of the component, bolt loosening, thread stripping, and strap bottoming out. If the tension in the strap is not sufficient, then the components may slip or separate, which can result in fatigue and fretting failure of the joint. Hence, it is important to understand the relationship between applied preload and corresponding stresses generated in the strap [2]. This paper presents work on the calculation of design margins of strap joints, such as slip and separation margins and hoop stress margins, with respect to yield and UTS. The bolt proof, thread strip margin, spot weld strength margin, trunnion and pin yield margin, fatigue, and fretting are out of the scope of this paper.

Manuscript received on 29 July 2023 | Revised Manuscript received on 08 August 2023 | Manuscript Accepted on 15 August 2023 | Manuscript published on 30 August 2023.

* Correspondence Author

Aniket Pawar*, Department of Design Engineering, Pimpri Chinchwad College of Engineering, Pune (Maharashtra), India. Email: pawaram30@gmail.com, ORCID ID: [0000-0001-5354-6371](https://orcid.org/0000-0001-5354-6371)

Kishor Deshmukh, Applied Mechanics Engineer-Technical Specialist, Cummins Technical Center India, Pune (Maharashtra), India. Email: kishor.deshmukh@cummins.com, ORCID ID: [0009-0006-6466-4713](https://orcid.org/0009-0006-6466-4713)

© The Authors. Published by Blue Eyes Intelligence Engineering and Sciences Publication (BEIESP). This is an open access article under the CC-BY-NC-ND license <http://creativecommons.org/licenses/by-nc-nd/4.0/>

II. LITERATURE REVIEW

The Strap joints are frequently used in the automobile industry. Despite their wider application in industry, there is no established method to calculate the design margins. The workings of the flat band clamp and V-Section Band Clamp are similar to the strap joints. The equations presented by K. Shoghi et al. are used for calculating stresses in band clamps [1, 2, 6]. The behavior of band clamps under external loading is proposed by Z.Y. Qin et al [3]. The parametric studies are performed to investigate the effect of preload on the band clamp. The FEA model of the band clamp model is created, and the analysis results are validated by performing static experiments by Z.Y. Qin et al [4]. The existing methods were referred to calculate strap joint design margins, and a new method is proposed in this paper.

III. DESIGN MARGIN CALCULATION BY ANALYTICAL METHOD

The analytical method is used for calculating strap yield, slip, and separation margins. The design margin calculations can be easily performed by the design engineer; if the design is not meeting the required acceptance criteria, the engineer can make changes to the design and recheck the margin. This will eliminate the excessive time required for FEA simulations and multiple iterations in designs [4]. The working of strap joint is similar to band brakes. This concept is used for the calculation of hoop stresses in straps. The margins calculated from analytical calculations were then compared with the design margins from FEA. The design margin calculation methods established in this paper have been validated by the test data.

A. Assumptions

For calculating design margins analytically, some assumptions based on engineering practice were made, such as:

- The materials properties are assumed to be linear.
- The design margins for ATS with only two straps can be calculated using the analytical method.
- The coefficient of friction between strap material and the ATS body is assumed to be 0.2.
- A damping value of 2.5% was used to calculate the PSD response curve.
- The bolt preload calculation is based on the bolt size with an assumed nut factor (K).
- The torque coefficient is assumed to have a value of 0.23.
- 30% variation in preload is assumed for torque-controlled tightening.
- Preload loss due to cold relaxation is assumed to be 30%.

B. Inputs Required

A CAD model of the assembly is required for measurement of bracket angle, number of straps, strap angle, strap width, slot width for T-Bolt and trunnion, radius of strap, and location of the CG of the body with respect to straps. Also, the mass of the assembly is required, which can be measured from CAD. The end of the strap is formed by bending the strap band into a loop and welding it. The spot-welding method is used. The assembly parameters, like

bolt parameters, torque input, and torque coefficient, are required for calculating the worst-case minimum and worst-case maximum load cases. For calculating slip and separation margin in axial and lateral/vertical directions, inputs such as PSD profile and first natural frequency in axial and lateral/vertical axes are required. It is recommended to use the baseline PSD Profile for calculating design margins.

C. Load Cases

There are two possible failure modes in the loading conditions that can be predicted, such as failure due to maximum and minimum loading assembly conditions. Table I shows the failures caused by different loading conditions. Higher values of preloads result in better clamping of the joint and a better connection. But excess preloads also result in higher tensile forces on the strap, which in turn leads to its failure by yielding and fracture. Over torquing the bolt may cause it to yield, break, or crack.

Table 1: Modes of Failure in Strap Joint

Worst Case Maximum for Assembly Loads	Worst Case Minimum for Operating Load
<ul style="list-style-type: none"> • Strap yielding • Bolt yielding/failure • Thread Stripping • Spot Weld failure • Trunnion and pin yield 	<ul style="list-style-type: none"> • Longitudinal Slip • Vertical Unloading • Lateral Unloading • Longitudinal Unloading

Let, T = Assembly torque,

t = prevailing torque,

k = torque coefficient,

D = Nominal bolt diameter

$$P_{nom} = \frac{T - t}{k \times D} \quad (1)$$

Worst Case Minimum Loading: -

$$\text{Minimum Preload} = 0.7 \times P_{nom} \quad (2)$$

After cold relaxation, 30% of the preload is lost. Hence, Worst Case Minimum Preload,

$$P_{min} = 0.7 \times \text{Minimum Preload} \quad (3)$$

This worst-case minimum preload, along with acceleration loads in axial and lateral/vertical directions, is used to calculate slip and separation margins.

Worst Case Maximum Loading: -

$$\text{Maximum Preload} = 1.3 \times P_{nom} \quad (4)$$

After cold relaxation, 30% of the preload is lost. Hence, Worst Case Maximum Preload,

$$P_{max} = 0.7 \times \text{Maximum Preload} \quad (5)$$

This worst-case maximum preload is used to calculate strap yield margins.

D. Slip and Separation Margin

Failure of a Strap joint mainly occurs due to an external load, which may be a bending load, an axial load, a rotational load, or any combination of these loads.

It is important to have sufficient axial load capacity available in these clamped joints to prevent leakage and untreated exhaust emissions. During operation, the very large preload loss may lead to an insufficient clamping load and cause slip or separation in the joint.



Below are major failure modes because of Joint slip or separation (insufficient axial load is one of the causes of failure).

- Small separation with elastic deformation of the strap, where the ATS body reconnects again after the axial load is taken off. Although no physical damage takes place, this failure is undesirable in After-treatment applications.
- Irrecoverable separation occurs when the strap moves over the body, resulting in total failure of the strap joint.
- Fatigue failure of joints is caused by separation of joints, due to which the joints will not work together as one unit. The load path changes, and the stress amplitude increases.

If the axial force acting on the ATS is greater than the frictional force due to preload, slip occurs between the ATS body and straps. Friction force due to bolt preload depends on reaction force due to the bracket. So, it is required to calculate the axial force due to the G load and the frictional force caused by the bolt preload. It will give the slip margin. Slip occurs in the axial direction, and Separation occurs in the lateral and vertical directions. The acceleration load is calculated from the input PSD Profile. The input PSD profile is converted to a 1 Hz delta frequency. The SDOF response curve for axial and lateral/vertical axes at 1 Hz delta frequency is calculated. The SDOF response is considered since it is assumed that most of the force transmission occurs in the first mode of the fixture. The input PSD profile is then multiplied by the square of the response curve to get the PSD response. The area under the PSD response curve is calculated to obtain the RMS accelerations in g [5]. It has been assumed that slip and separation design margins are affected by a design load of three times RMS. So, the acceleration load is calculated for the axial and lateral/vertical directions. This acceleration load is used to calculate slip and separation margins.

▪ **Longitudinal Slip Margin**

Refer [Figure 2](#) for free body diagram for longitudinal loading condition

T = Worst Case Minimum Preload

α_1 & α_2 = Bracket angle

m = After Treatment Mass

a = Acceleration G load in axial direction

μ = Coefficient of friction

T_v = Total bracket Reaction Force

X_f & X_r = longitudinal distance of CG from contact bracket points

y = vertical position of CG with respect to top of the ATS body

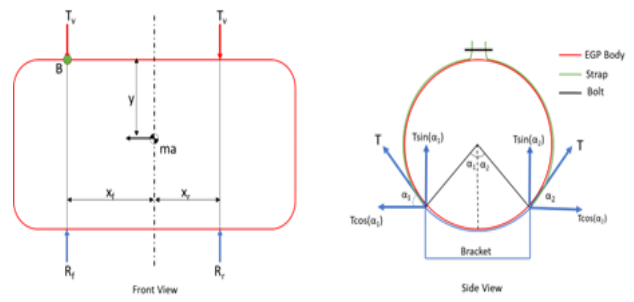

Figure 2. FBD of Longitudinal Loading

$$T_v = T \sin \alpha_1 + T \sin \alpha_2 \tag{6}$$

$$\text{Longitudinal Slip Margin} = \frac{ma}{2 \times \mu \times T_v} \tag{7}$$

▪ **Vertical Separation Margin**

The [Figure 3](#) shows free body diagram of vertical loading.

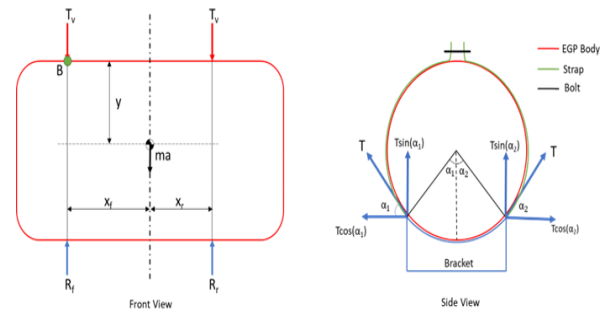

Figure 3. FBD of Vertical Loading

For vertical loading condition, Reaction load is given by,

$$R_f = T_v - ma \left(\frac{x_f}{x_f + x_r} \right) \tag{8}$$

And

$$R_f = T_v - ma \left(\frac{x_r}{x_f + x_r} \right) \tag{9}$$

$$\text{Reduction in reaction load, } R_v = \frac{\min(R_f, R_f)}{T_v} \tag{10}$$

$$\text{Separation Margin in Vertical Direction} = \frac{1}{1 - R_v} \tag{11}$$

▪ **Lateral Separation Margin**

The [Figure 4](#) shows the free body diagram of lateral loading

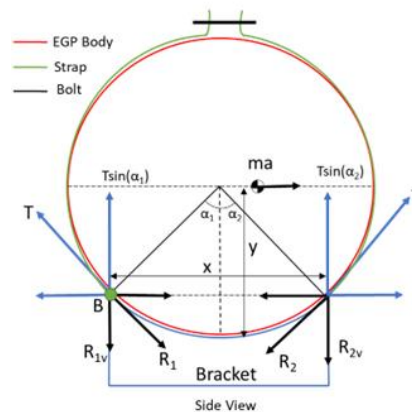

Figure 4. FBD of Lateral Loading

The ratio of reaction in loaded condition to reaction in unloaded condition is given by,

$$R_l = \frac{R_{loaded}}{R_{unloaded}} = 1 - \left(\frac{ma}{2 \times T \sin \alpha_2} \right) \left(\frac{y}{x} \right) \quad (12)$$

$$\text{Separation Margin in Lateral Direction} = \frac{1}{1 - R_l} \quad (13)$$

E. Strap Yield Margin

When the torque is applied to the bolt, a preload is induced, which causes friction between the strap and the ATS body. Due to this preload, hoop stress is induced in the strap [6]. The hoop stress is induced along the circumferential direction, and it varies with respect to the angle. Shoghi et al. (2003) [1] proposed the exponential relation between the forces in the strap and the applied preload for flat band clamps. The ratio of bolt preload to force at an angle around the strap can be calculated from the equation

$$\frac{F_\beta}{F_\alpha} = e^{\mu(\beta-\alpha)} \quad (14)$$

Where, F_β is bolt preload

F_α is force at an angle around strap

μ is coefficient of friction between strap and ATS

β is subtended half angle of strap

α is angle at which force is calculated

The hoop stress at angle α is given by,

$$\sigma_\alpha = \frac{F_\beta}{wte^{\mu(\beta-\alpha)}} \quad (15)$$

And the contact pressure between strap and ATS body is given by

$$p = \frac{\sigma_\alpha \times t}{R} \quad (16)$$

Where, w is strap width, t is strap thickness and R is radius of strap

Let, σ_{max} = Maximum Hoop Stress

YTS = Yield Strength of Strap Material

UTS = Ultimate Strength of Strap Material

$$\text{Strap Hoop Stress Margin wrt YTS} = \frac{YTS}{\sigma_{max}} \quad (17)$$

$$\text{Strap Hoop Stress Margin wrt UTS} = \frac{UTS}{\sigma_{max}} \quad (18)$$

IV. DESIGN MARGIN FROM FEA

Figure 5 shows the block diagram of the simulation flow for calculating the design margin using FEA. First, the geometry is imported into Ansys. The geometry cleaning operations, such as removing penetration and gaps in the assembly, are performed before meshing. The meshing with the proper element type is performed on the assembly. The contacts are defined, and boundary conditions are applied according to the requirements of the simulation. For calculating stress margins, the worst-case maximum load is applied. The hoop stresses are extracted.

For calculating slip and separation margin, assembly plus operating loading conditions are applied. The assembly load in this case is the worst-case minimum load. First, a nonlinear assembly simulation is performed to calculate the bracket reaction forces for assembly loading. Then the PSD analysis is performed with the same boundary conditions to calculate

the bracket reaction forces in operating conditions. These bracket reaction forces are used to calculate the slip and separation margins for the strap joint assembly.

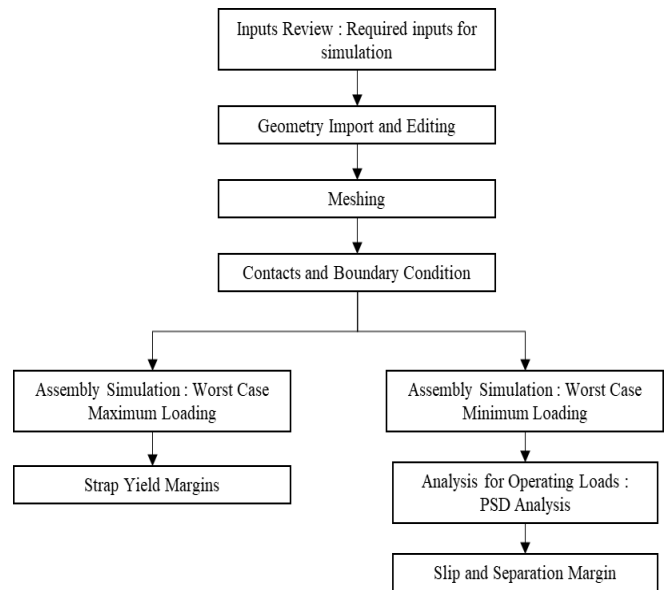

Figure 5. Flow Chart of Design Margin Calculation Process

A. Assumptions

The following assumptions were made while performing the FEA simulation:

- The coefficient of friction is assumed to be 0.2.
- All-important contacts are considered non-linear contacts.
- Temperature effects are not considered.
- The mass of the system and G load are required to calculate the inertia load, which will be used for slip margin calculations.

V. CASE STUDY: STRAP JOINT YEILD MARGIN CALCULATION

A. Geometry

The CAD model of the ATS assembly is imported into Ansys for static analysis. As the assembly is complicated, it takes time to solve the simulation. So, to reduce the required solution time, midsurfaces were extracted from geometry. Bolt, trunnion, and nut assemblies are kept as a solid body for analysis.

Table 2: Dimensions of Strap

Sr. No	Input	Value	Unit
1	Strap Angle	317	Degrees
2	Strap Width	19	mm
3	Strap Thickness	1.25	mm
4	Strap Radius	147.8	mm

Table 3: Material Properties of Strap Joint

Sr. No	Input	Value	Unit
1	Material	SS349	-
2	Density	7850	Kg/m ³
3	Young's Modulus	200	GPa
4	Poisson Ratio	0.3	-
5	Tensile Yield Strength	290	MPa
6	Tensile Ultimate Strength	460	MPa

B. Meshing

The midsurfaces were meshed with 2D shell elements, and their respective thicknesses are assigned to them. To get proper contact pressure between strap and ATS body, the same element size is kept at least in the contacting faces. Quad elements are used for meshing midsurfaces, and hex elements are used for meshing solid surfaces.

C. Contact

Frictional contact is applied between all the contacting faces of the strap and the ATS body. The coefficient of friction is assumed to be 0.2. The initial gaps and initial penetration, if present, are removed by geometry cleaning. Contact status shows whether parts are touching or separated.

D. Boundary Conditions

The worst-case maximum bolt preload is applied to the T-bolt. The Preload is divided into a number of load steps to avoid the convergence issue. The preload is applied as shown in fig.

The fixed support is applied to the ends of the ATS body. The point mass of the exhaust gas sensor, NOx sensor, and connecting pin is applied.

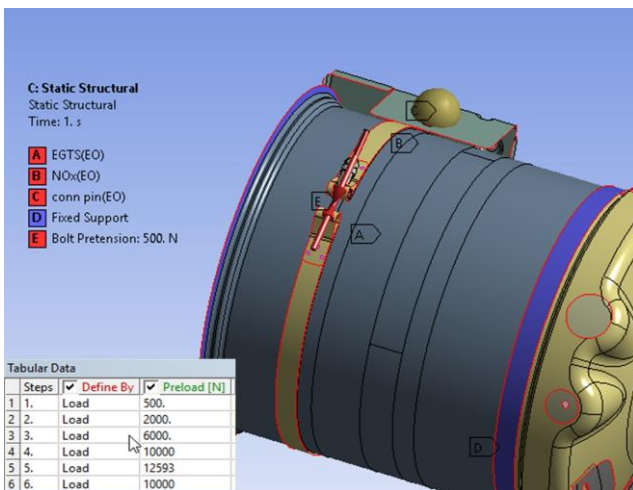

Figure 6. loading and Boundary conditions

E. Hoop Stress

The hoop stresses in the strap are calculated from eqⁿ (15). From the FEA simulation of the strap, hoop stresses were extracted. Figure 7 shows the variation of hoop stresses in the strap. The difference between calculated stress values and values from the FEA is around 5%. The difference in result is because of the assumptions made in calculations and the uncertainty in inputs. The contact pressure between the strap and the ATS Body is also measured and compared with the test results.

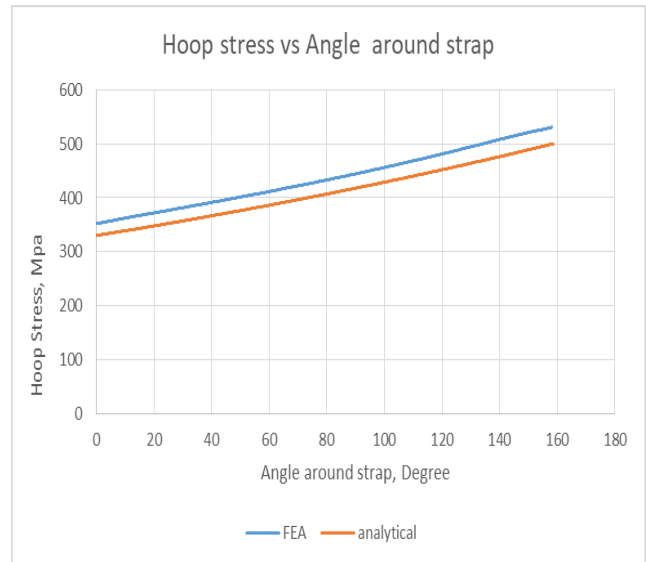

Figure 7. Comparison of Hoop Stress from FEA and Analytical Results

F. Correlation with Testing

The ATS system was tested under the same assembly conditions. The specified preload is applied to the bolt by using a torque wrench. The Strain gauges were mounted at different locations on the strap, as shown in Figure 8. The first strain gauge is mounted near the bolt, the second is mounted at 90° from the bolt, and the third is mounted at 180° from the bolt.

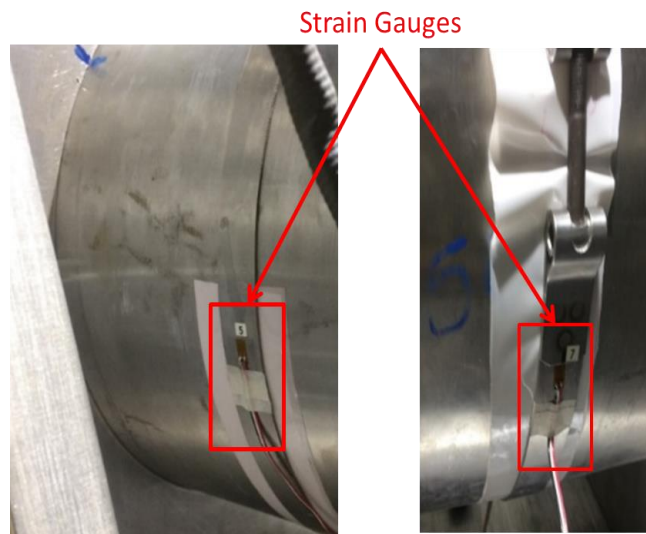

Figure 8. Strain Gauges Mounted on ATS Body

The variation between strain measured from the test and FEA is about 4-6%, as shown in Figure 9.

The contact pressure distribution between strap and body is also measured by testing. The contact pressure distribution on the strap is shown in Figure 10.

Prediction of Strap Joint Design Margin in After Treatment System

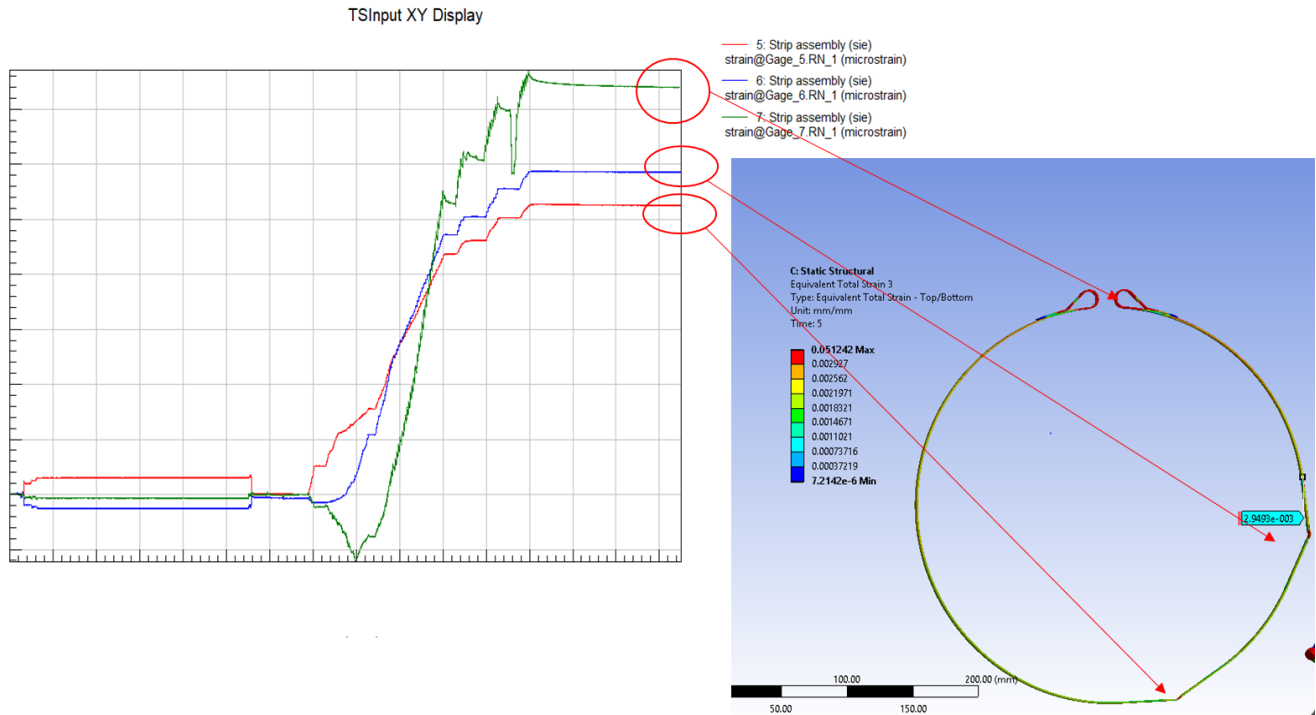

Figure 9. Strain Measured from Test vs FEA

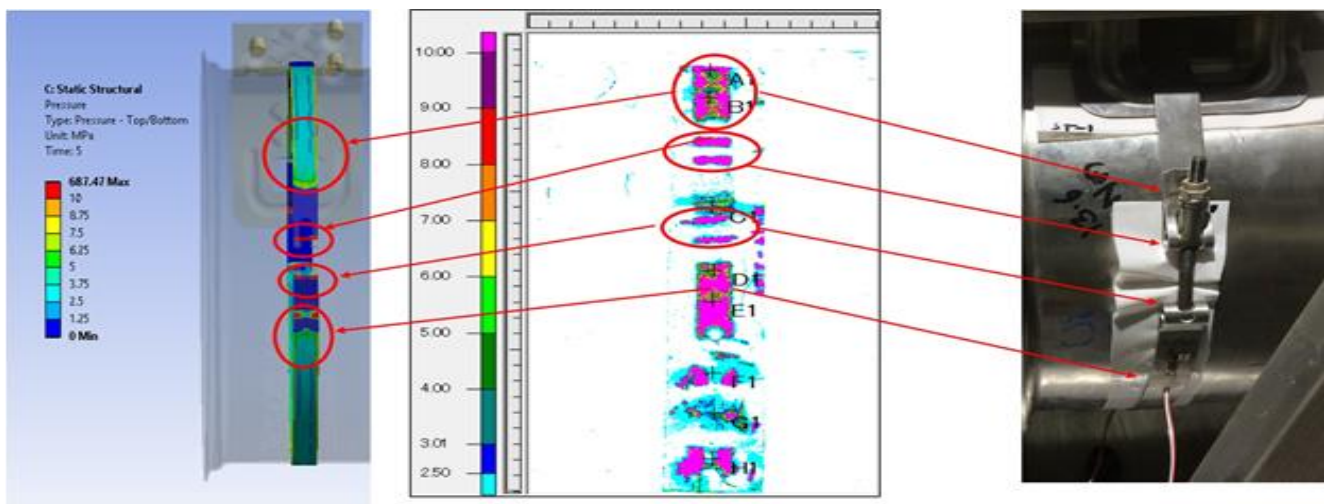

Figure 10. Contact Pressure Distribution

VI. CASE STUDY: SLIP AND SEPARATION MARGIN CALCULATIONS

An ATS assembly with two strap joints was imported into Ansys. For calculations of slip and separation margin by this method, a first assembly simulation with a minimum preload condition is performed. The bracket reaction forces were extracted from the analysis. Then the PSD analysis is performed on the assembly with assembly plus operating loading conditions. The accelerated PSD profile is used for this analysis. The two-sigma reaction forces caused by PSD excitations are extracted. The reaction force in the axial direction is considered for the calculation of the slip margin. The maximum reaction force from the lateral and vertical directions is considered for the calculation of the separation margin.

Table 4: Inputs for Slip and Separation Margin Calculation

Sr	Input	Value	Unit
1	ATS Mass	50	kg
2	Bracket Angle	45	Degrees
3	No. of straps	2	-
4	Longitudinal position of CG from bracket contact points	x_f	240.11 mm
		x_r	205.98 mm
5	Vertical position of CG with respect to top of module	y	140.67 mm
6	Lateral position of bracket contact points	x	91.7 mm

Table 5: Slip and Separation Margin using FEA

Slip and Separation Margin Calculation using Accelerated PSD (Recommended to use 2-Sigma Forces) (Shaker Test Results)									
Strap Joint	PSD Analysis with Accelerated Profile	Bracket Contact Forces	ATS Longitudinal Direction	ATS Lateral Direction	ATS Vertical Direction	Predicted Force to Slip	Operating Unloading Force	Separation Margin	Slip Margin
		PSD Excitation Direction							
Joint 1 - Inlet	Accelerated Profile (2 Sigma Forces)	ATS Longitudinal Direction	2184	595	926	2184	926	3.62	0.86
Joint 1 - Outlet	Accelerated Profile (2 Sigma Forces)	ATS Longitudinal Direction	1844	702	703	1844	703	4.77	1.02

A. Slip Margin Calculation

The Slip margin by FEA is calculated by the following formula:

$$\text{Slip Margin} = \frac{R_a \times \mu}{R_o} \tag{19}$$

The slip margin by analytical method is calculated using (7).

Here, the slip margin calculated by the FEA method is 0.86, and the slip margin calculated by the analytical method is 0.75.

B. Separation Margin Calculation

For the calculation of the separation margin, the maximum reaction force from the lateral and vertical directions is considered. The separation margin is calculated as

$$\text{Separation Margin} = \frac{R_a}{R_o} \tag{20}$$

Separation margin in lateral and vertical direction is calculated using (11) & (13).

In this case, separation margin by FEA is 3.62 and separation margin by analytical method is 3.72.

Table V shows the slip and separation margin calculation using FEA.

VII. CONCLUSION

The strap joints provide flexible and adjustable connections for After Treatment System components from the exhaust system to the chassis of the vehicle. As strap joints are an important component of the After Treatment System, they should be designed such that they do not yield, break, or crack. The method to calculate the design margin using analytical and FEA methods was developed in this paper. The variation in design margin between the analytical and FEA methods is about 5%. The design margins calculated were validated with test results. The critical parameters affecting the design margin are strap width, strap thickness, coefficient of friction, strap angle, bracket angle, and location of CG with respect to the strap joint. If the design margin does not meet the required criteria, it is recommended to change the design. The stresses and margins predicted from this procedure are intended to provide a direct conclusion as to whether the analyzed strap joint sustains the applied preload condition or not. To make a correct judgment about the obtained results, FEA simulation is performed and checked with the calculated margins.

DECLARATION

Funding/ Grants/ Financial Support	No, we did not receive.
Conflicts of Interest/ Competing Interests	No conflicts of interest to the best of our knowledge.
Ethical Approval and Consent to Participate	No, the article does not require ethical approval and consent to participate with evidence.
Availability of Data and Material/ Data Access Statement	Not relevant.
Authors Contributions	All authors have equal participation in this article.

REFERENCES

1. K Shoghi, H V Rao and S M Barrans, "Stress in flat section band clamp" Volume: 217 issue: 7, page(s): 821-830, Issue published: July 1, 2003 <https://doi.org/10.1243/095440603767764462>
2. K Shoghi, H V Rao and S M Barrans, "Plastic deformation in flat-section band clamps" Issue published: October 22, 2004
3. Z.Y. Qin, S.Z. Yan, F.L. Chu, "Analytical modeling of clamp band joint under external bending moment" Contents lists available at SciVerse ScienceDirect, Accepted 5 December 2011
4. Z.Y. Qin, S.Z. Yan, F.L. Chu, "Finite element analysis of the clamp band joint", Applied Mathematical Modeling 36 (2012) 463-477. <https://doi.org/10.1016/j.apm.2011.07.022>
5. <https://endaq.com/pages/power-spectral-density>
6. K Shoghi, S M Barrans and H. Rao, "Stress in V-section band clamps", SAE 17-218-C3-251 <https://doi.org/10.1243/095440604322900381>

AUTHORS PROFILE



Aniket Pawar, Student, M.Tech (Mechanical Design Engineering) Pimpri Chinchwad College of Engineering, Pune Maharashtra, India.





Kishor P. Deshmukh, M.Tech Automotive Engineering Applied Mechanics Engineering – Technical Specialist Cummins Technical Centre India, Pune, Maharashtra, India,

Disclaimer/Publisher’s Note: The statements, opinions and data contained in all publications are solely those of the individual author(s) and contributor(s) and not of the Blue Eyes Intelligence Engineering and Sciences Publication (BEIESP)/ journal and/or the editor(s). The Blue Eyes Intelligence Engineering and Sciences Publication (BEIESP) and/or the editor(s) disclaim responsibility for any injury to people or property resulting from any ideas, methods, instructions or products referred to in the content.