

# Steel Work Design and Analysis of a Manual Lawn Mower

Okolie Paul C<sup>1</sup>, Sylvester Emeka Abonyi<sup>2</sup>, Okolie Uchenna Onyebuchi<sup>3</sup>,  
Chikelue Edward Ochiagha<sup>4</sup>

<sup>1</sup> Department of Mechanical Engineering, Nnamdi Azikiwe University, Awka, Anambra State Nigeria.

<sup>2</sup> Department of Electrical Engineering, Nnamdi Azikiwe University, Awka, Anambra State, Nigeria.

<sup>3</sup> Research and Development, Electronics Development Institute Awka Capital territory Anambra State Nigeria.

<sup>4</sup> 3Series Premium Nigeria Limited Awka, Anambra State, Nigeria

Corresponding author email: [s.abonyi@unizik.edu.ng](mailto:s.abonyi@unizik.edu.ng)

DOI: <https://doi.org/10.5281/zenodo.8369633>

Published Date: 22-September-2023

---

**Abstract:** This work presented the design and construction of a manually powered lawn mower as well as the stress analysis of the blade. The solid model of the lawn mower design was done using Solid works software. The materials utilized for the construction were selected following standard material selection processes. The required cutting speed was achieved by proper gear arrangement which transferred the rational motion of the wheels to the blade, consequently increasing the speed by about 300%. The average cutting capacity of the lawn mower is 62.48 m<sup>2</sup>/hr. The stress analysis on the blade using the simulation tool of the solid works software gave a maximum von mises stress that is 252 times less than the yield strength of the blade material. Also, a maximum deformation of 0.00271mm obtained from the analysis is quite infinitesimal hence, the blade can withstand both stress and deformation resulting from the cutting operation.

**Keywords:** grass, lawn mower, blade, cutting speed, cutting capacity.

---

## 1. INTRODUCTION

Generally, grasses have the ability to grow in various conditions which makes them a major concern especially in residential areas and external environment generally [1]. Prior before now, manual cutting methods were employed in the cutting of grasses in schools, sports tracks, fields e.t.c. This strategy for manual cutting is tedious due to human effort requirement in the cutting process. Additionally, for the purpose of aesthetics, the maintaining of regular cutting level has proven difficult when utilizing the manual cutting method [2]. Similarly, the use of manual cutting method is associated with a high cost of execution, this is because the cost of employing humans to cut grass covering a given area is usually more than the cost of using a lawn mower [3].

Besides, environmental mindfulness on utilization of grass cutting machines (noise, oil pollution, etc.) the lawn mower has gotten an extraordinary enthusiasm among buyers. Subsequently, people are scanning for approaches to lessen these environmental factors and contamination [4, 5]. It was this technological and innovative era that propelled the invention of lawn mower also known as lawn mower. A lawn mower is a machine utilized for cutting grass or lawn (any area of tough grass which are usually cut like a private garden or open park) [6]. A wide range of lawn mowers exists and have been made each fit to a specific purpose [7, 8].

The choice of design of lawn mower and user preference depends on several factors. Such factors could be the cost of purchase of the mower, the cost of maintenance, the ease of use, the efficiency, and sometimes the kind of work to be done with it. Every user has preferences and these preferences are what sponsors their decision on which kind of mower to use. Sophisticated lawn mowers, especially the electrical and internal combustion engine powered mower tend to pose threats to the lives of the users. The cutters or blades sometimes gets disconnected from the shaft and flies in the air at a very fast

speed. Designed grass cutters include solar energy powered [9], cutting robot [10], battery powered [11], petrol engine powered [12], pedal operated [13].

## 2. MATERIALS AND METHOD

### 2.1 Tools and Equipment Used

The following tools and equipment were used for the construction of the lawn mower: Hack Saw, Hammers, Lathe Machine, Milling Machine, Drilling Machine, Jig Saw, Arc Welding Machine, Weighing Scale, Hand Grinder, Scriber, Pliers, Cutting Disc, Grinding Disc and Bending Machine.

### 2.2 Material Selection

To achieve a good design factors such as cost, strength, machinability, availability, etc. must be given full consideration in the selection of materials [14, 15]. Table 1 shows the materials selected for the various parts and the reason for their selection.

**Table 1: Selection of materials for lawn mower**

Part	Performance Requirement	Selected Material	Criteria for Selection
Blades	- Hardness	High Speed Steel	- Material Properties (hardness, wear resistance)
	- High wear Resistance		- Material Cost
	- Tensile Strength		- Availability (readily available)
	- Corrosion Resistant		- Corrosion Resistance (high resistance)
Gear	- Ductility	High Carbon Steel (HCS)	- Material Properties (high strength)
	- High strength		- Material Cost
	- Surface hardness		- Availability (readily available)
	- Fatigue Strength		
Handle	- Ductility	Galvanized Steel Pipe	- Material Properties (good ductility)
	- Ease of Welding		- Material Cost (relatively cheap)
	- Strength		- Availability (readily available)
Rollers	- High Abrasion Resistance	Teflon	- Material Properties (high abrasion resistance)
			- Material Cost (relatively cheap)
			- Availability (readily available)
Other Body Parts	- Ductility	Mild Steel	- Material Properties (high ductility and strength)
	- Ease of Welding/joining		- Material Cost (relatively cheap)
	- High Strength		- Availability (readily available)
			- Good weldability

### 2.3 Machine Design

The machine was designed using the solid works 2015 software as shown in figures 1 and 2. While figure shows the assembled design of the machine, figure 2 displays all the parts of the machine in an exploded view.



**Figure 1: Assembled view of the lawn mower design**

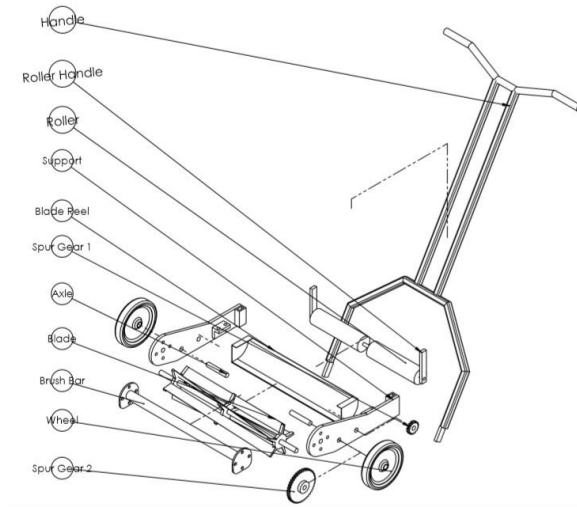

Figure 2: Exploded view of the lawn mower design

**2.3.1 Determination of the Revolution per minutes of the wheel**

Wheel is contact point of the mower with the lawn. It is covered with tire in order to give grips to the wheel during rotation. The wheel is connected to the attached to the axle which moves the entire system. Speed of wheel is given as:

$$V_w = \frac{\pi D_w N_w}{60} \tag{1}$$

The average forward speed for operational convenience is given as  $V_w=0.8\text{m/s}$

Where,  $D_w$ = Diameter of the wheel (m)

$N_w$ = Rotational speed of the wheel (rpm)

**2.3.2 Determination of the Revolution per minutes of the smaller gear**

The relationship between diameter of a gear, its module and number of teeth is given as

$$\text{Diameter of bigger gear, } D_b = m \times Z_b \tag{2}$$

$$\text{Diameter of small gear, } D_s = m \times Z_s \tag{3}$$

Where,  $m$ = Module of the gear

$Z_b$ = Number of teeth on the bigger gear

$Z_s$ = Number of teeth on the smaller gear

The simple gear speed ratio is given as,

$$\frac{N_b}{N_s} = \frac{D_s}{D_b} \tag{4}$$

Where,  $N_b$  = rotational speed of the bigger gear. This is same as the rotational speed of the wheel, that is  $N_b = N_w$

**2.3.3 Determination of Minimum Radius of the blade**

The design of the blade is such that it maximum shear stress does not exceed the shear stress of the grass. From Tresca’s criterion theory which states that failure occurs when the maximum shear stress  $\tau_b$  exceeds the shear strength with yielding in the uniaxial tension test. For a grass shear strength,  $\tau_{max}=112\text{N/mm}^2$ . Assuming a factor of safety (FS) of 1.4. The Maximum shear stress of the blade is given as:

$$\text{Maximum shear stress of the blade, } \tau_{blade} = \tau_{max} \times FS \tag{5}$$

The surface area of the blade is given as (Khurmi & Gupta, 2005) [16]:

**International Journal of Novel Research in Electrical and Mechanical Engineering**

 Vol. 11, Issue 1, pp: (14-23), Month: September 2023 - August 2024, Available at: [www.noveltyjournals.com](http://www.noveltyjournals.com)

$$A_{blade} = F_b / \tau_b \quad (6)$$

Where  $F_{blade}$  = the tangential force on the blade which is same as the human effort of pushing and averagely 100N.

The mean radius of the blade is given as

$$R_{blade} = \sqrt{A_{blade} / \pi} \quad (7)$$

**2.3.4 Determination of the power required to drive the machine**

Power required to drive the machine is given as given by Nkakini and Yabefa [17].

$$P_w = P_i + P_r \quad (8)$$

Power required to overcome the inertia of the machine is given as

$$P_i = W_m \times V_w \quad (9)$$

Power required to overcome the grass cutting resistance is given by Nkakini and Yabefa [17].

$$P_r = F_r \times R_{blade} \times w_s \quad (10)$$

Where  $W_m$  = weight of the machine. The approximate weight of the machine can be determined using the Solidworks 2018 software.

$F_r$  = Cutting Force which is same as the Tangential force on the blade,  $F_{blade}$

$R_{blade}$  = Minimum Radius of the blade

$w_s$  = Angular speed of the smaller gear, which is the same as the angular speed of the blade.

**2.3.5 Determination of the Power on the Cutter Cylinder**

Power on cutter cylinder is given by Nagarajan et al [18].

$$P_c = \frac{m_c \times g \times \pi \times D_c \times N_s}{60} \quad (11)$$

Mass of the cutter cylinder is given as:

$$m_c = l_c \times A_c \times \rho_c \quad (12)$$

Cross sectional area of the cutter cylinder is given as:

$$A_c = \frac{\pi d_c^2}{4} \quad (13)$$

Where g = Acceleration due to gravity (9.81m/s<sup>2</sup>)

$D_c$  = Diameter of the cutter cylinder

$A_c$  = Cross sectional area of the cutter cylinder

$l_c$  = Length of the cutter cylinder

$\rho_c$  = Density of the material of the cutter cylinder (mild steel) which is given as 7850kg/m<sup>3</sup>

**2.3.6 Determination of the Axial Stress on the Handle**

Axial Stress on the handle is given by Nagarajan et al [18].

$$\sigma_h = \frac{F_h}{A_h} \quad (14)$$

Cross sectional area of the handle is given as:

$$A_h = \pi \times d_h \times l_h \quad (15)$$

Where,  $d_h$  = Mean Diameter of the handle

$l_h$  = Length of the handle

$F_h$  = Force Applied on the handle, which is same as the tangential force on the blade which is same as the human effort of pushing and averagely 100N

The ultimate tensile strength of the material,  $\sigma_U = 8.41 \times 10^8 N/m^2$

### 2.3.7 Determination of the Minimum Diameter of the Shaft

Torque on Shaft is given as

$$T_{shaft} = \frac{P_c \times 60}{2\pi N_s} \tag{16}$$

Minimum diameter of the shaft is given as

$$d_{shaft} = \sqrt[3]{\frac{16 \times T_{shaft}}{\pi \times \tau_{max}}} \tag{17}$$

Where  $\tau_{max}$  = Maximum allowable shear stress of the shaft in which the maximum allowable shear stress of mild steel is  $2.52 \times 10^8 N/m^2$ .

## 3. RESULTS AND DISCUSSION

### 3.1 Computation of dimensions of parts

The computation of the specifications of the various parts is presented in table 2.

**Table 2: Computation of the particulars of the various parts**

Initial Data	Computation	Results
<b>Determination of the Revolution per Minutes of the wheel</b>		
Speed of the wheel, $V_w = 0.8m/s$ Diameter of the wheel, $D_w = 0.16m$	From Equation 1, $N_w = \frac{60 \times 0.8}{\pi \times 0.16} = 95.5rpm$	Revolution per Minutes of the wheel, $N_w = 95.5rpm$
<b>Determination of the Revolution per minutes of the smaller gear</b>		
Module of the gear, $m = 0.0029m/tooth$ Number of teeth on the bigger gear, $Z_b = 40teeth$ Number of teeth on the smaller gear, $Z_s = 15teeth$ $N_b = N_w$	From Equation 2, Diameter of bigger gear, $D_b = m \times Z_b$ $\Rightarrow D_b = 0.0029 \times 40 = 0.116m$ From Equation 3, Diameter of small gear, $D_s = 0.0029 \times 15 = 0.0435m$ From Equation 4, $N_s = \frac{95.5 \times 0.116}{0.0435} = 254.7rpm$	Revolution per minutes of the smaller gear, $N_s = 254.7rpm$
<b>Determination of Minimum Radius of the blade</b>		
Grass shear strength, $\tau_{max} = 1.12 \times 10^8 N/m^2$ Factor of safety (FS)=1.4 Tangential force on the blade, $F_{blade} = 100N$	From Equation 5, Maximum shear stress of the blade, $\tau_{blade} = 1.12 \times 10^8 \times 1.4 = 1.568 \times 10^8 N/m^2$ From Equation 6, Surface area of the blade, $A_{blade} = \frac{100}{1.568 \times 10^8} = 6.38 \times 10^{-7} m^2$	Minimum Radius of the blade, $R_{blade} = 4.51 \times 10^{-4} m$

	From Equation 7, $R_{blade} = \sqrt{A_{blade}/\pi} = \sqrt{\frac{6.38 \times 10^{-7}}{\pi}} = 4.51 \times 10^{-4}m$	
<b>Determination of the power required to drive the machine</b>		
The weight of the machine ,from Solidworks 2018 software, $W_m = 37.77N$ Cutting Force, $F_r = 100N$ Angular speed of the smaller gear, $w_s = 26.67rad/s$	From Equation 9, Power required to overcome the inertia of the machine, $P_i = 37.77 \times 0.8 = 30.21W$ From Equation 10, Power required to overcome the grass cutting resistance, $P_r = 100 \times 4.51 \times 10^{-4} \times 26.67 = 1.2W$ From Equation 8, $P_w = 30.21 + 1.2 = 31.41W$	Power required to drive the machine, $P_w = 31.41W$
<b>Determination of the Power on the Cutter Cylinder</b>		
Diameter of the cutter cylinder, $D_c = 0.03m$ Length of the cutter cylinder, $l_c = 0.494m$ Density of the material of the cutter cylinder (mild steel), $\rho_c = 7850kg/m^3$ Acceleration due to gravity, $g = 9.81m/s^2$	From Equation 13, Cross sectional area of the cutter cylinder, $A_c = \frac{\pi \cdot 0.03^2}{4} = 7.07 \times 10^{-4}m^2$ From Equation 12, Mass of the cutter cylinder, $m_c = 0.494 \times 7.07 \times 10^{-4} \times 7850 = 2.74kg$ Power on cutter cylinder, $P_c = \frac{2.74 \times 9.81 \times \pi \times 0.03 \times 254.7}{60} = 10.76W$	Power on the Cutter Cylinder, $P_c = 10.76W$
<b>Determination of the Axial Stress on the Handle</b>		
Mean Diameter of the handle, $d_h = 0.019m$ Length of the handle, $l_h = 0.588m$ $F_h = 100N$	From Equation 15, Cross sectional area of the handle, $A_h = \pi * 0.019 * 0.588 = 0.035m^2$ From Equation 14, $\sigma_h = \frac{100}{0.035} = 2847.5N/m^2$	Axial Stress on the Handle, $\sigma_h = 2847.5N/m^2$
<b>Determination of the Minimum Diameter of the Shaft</b>		
Maximum allowable shear stress of the shaft, $\tau_{max} = 2.52 \times 10^8 N/m^2$	From Equation 16, Torque on Shaft, $T_{shaft} = \frac{10.76 \cdot 60}{2 \cdot \pi \cdot 254.7} = 0.403Nm$ From Equation 17, $d_{shaft} = \sqrt[3]{\frac{16 \cdot 0.403}{\pi \cdot 2.52 \cdot 10^8}} = 8.145 \times 10^{-9}m$	Minimum Diameter of the Shaft, $d_{shaft} = 8.145 \times 10^{-9}m$

### 3.2 Results of the Performance Evaluation

The performance of a lawn mower is what determines the suitability and preference. It tells the user how well the lawn mower can get the job done. As discussed in chapter three, there are three basic performance factors to be evaluated, which are grass height ratio, cutting efficiency of the lawn mower, and capacity of the lawn mower.

#### 3.2.1 Results of Grass Height Ratio Evaluation

To determine the grass height ratio, a grassland area of 4m<sup>2</sup> was chosen at random from a vast piece of grassland and 20 grasses were tagged. The height of the tagged grasses was measured and the lawn mower was used to cut the grasses within the 4m<sup>2</sup> area. After the grasses were cut, the heights of the tagged grasses were also measured to get the results below and the grass height ratio was determined.

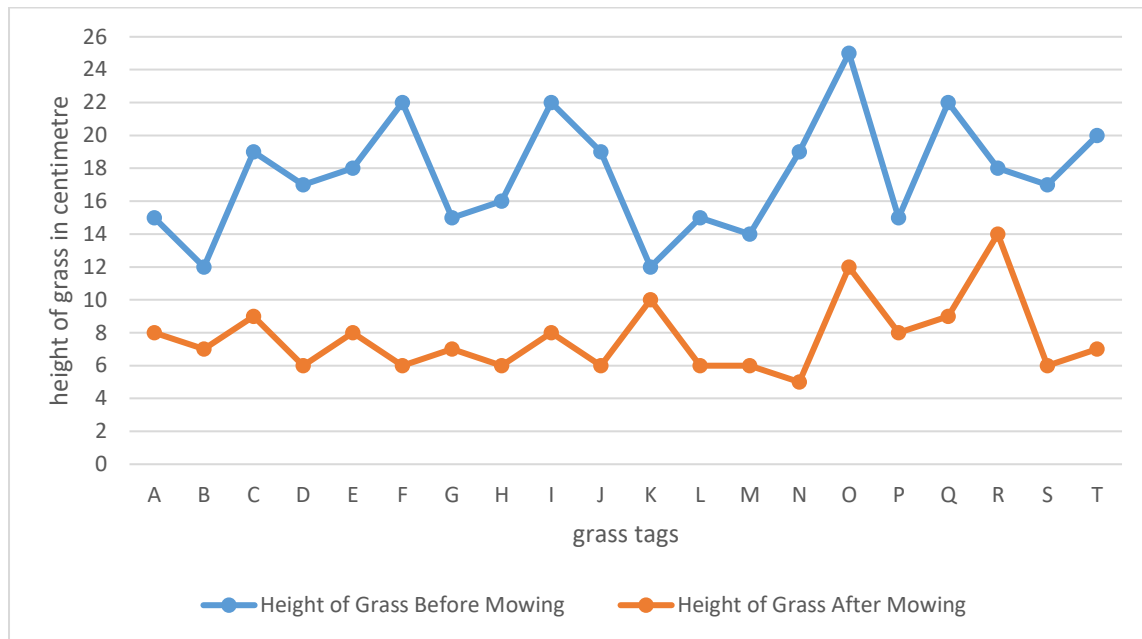

Figure 3: A comparison of the height of grass before mowing and after mowing

Table 3 Determination of the grass height ratio

Average height before mowing (cm)	Average height after mowing (cm)	Grass Height Ratio
17.6	7.7	2.29

The results in table 3 show an average height of 7.7cm after cutting the grasses with the lawn mower. According to Bello et al [19, 120], a cutting height of 5mm-9mm is acceptable as a good height, with 5mm as best height. This implies that the lawn mower meets up to standard, and would produce a good enough height of grass. Though height preferences vary for different users or owners of lawns. Some lawn owners prefer a higher grass height. A varying height of grass after cut was observed across the samples taken. This is due to the varying walking speed of the operator which directly affects the speed of the rotating cutting blade. Also, not every part of the blade is in contact with the grass at all times. This is because of the design of the blade, hence, the varying heights of the grass after cut.

### 3.2.2 Results of Cutting Efficiency of the Lawn mower

In determining the cutting efficiency of the lawn mower, 4m<sup>2</sup> area of grassland was cut using the lawn mower, and the area with a height exceeding the desired height of 80mm (this was determined from the average height of grass after cut as shown in table 4.1 above) was calculated. This area was determined by identifying areas with heights above 80mm which cannot be bounded by a 100mm diameter circle (only these were counted). All uncut areas were evaluated as a best approximated rectangle. All of such areas were calculated and summed and subtracted from the total area mowed to give the result as shown below in table 4

Table 4: cutting efficiency of the lawn mower

Area with Desired Height of Cut (m <sup>2</sup> )	Total Area Mowed (m <sup>2</sup> )	Cutting Efficiency
3.4	4	87.5%

From the cutting efficiency performance which was carried out, the cutting efficiency was computed as 85%. This implies a high cutting efficiency and indicates that the area cut by the lawn mower would have a high level of uniformity. Okafor [5] obtained a cutting efficiency of 89.55% for a self-powered (electrical source) lawn mower while Bello [19], obtained a cutting efficiency of 87.5% for an electrically powered brush cutter. Lawn mowers of high cutting efficiency of 95%-99% are best used where a high level of uniformity of grass height is required. Grasslands used as for sports such as football and grass lands used for aesthetic purposes most times require such high cutting efficiency. This lawn mower however, would not produce the desired result for such applications.

**3.2.3 Results of Capacity of the Lawn mower**

To determine the capacity of the lawn mower, four separate grasslands of 4m<sup>2</sup> in area each were cut using the lawn mower, and the time taken to cut the grasslands was measured. The capacity of the lawn mower was then computed using equation (20) and the average capacity from the four grasslands was computed. This value was taken to be the capacity of the lawn mower as shown in table 5.

**Table 5: Cutting Capacity of the lawn mower**

Area of grassland (m <sup>2</sup> )	Time taken to cut the grassland (minutes)	Cutting Capacity(m <sup>2</sup> /hr)
4	3.9	61.54
4	3.6	66.67
4	3.8	63.16
4	4.1	58.53

Hence, the average cutting capacity of the lawn mower is 62.48 m<sup>2</sup>/hr. A standard 100m<sup>2</sup> piece of grassland would take approximately 1 hour 36 minutes to be cut using the lawn mower. Okafor [5] obtained a capacity of 66.67m<sup>2</sup>/hr for a self-powered (electrical Source) lawn mower. The capacity of the lawn mower varies due to the difference in the walking speed of the operator. A high walking speed would produce a high cutting rate which would in turn produce a high cutting capacity.

**3.3 Stress and deformation analysis on blade**

The stress and deformation analysis of the blade was conducted using the simulation tool of the solid works 2015 software. For the purpose of obtaining accurate simulation results, the mesh model of the blade was first developed as shown in figure 4.

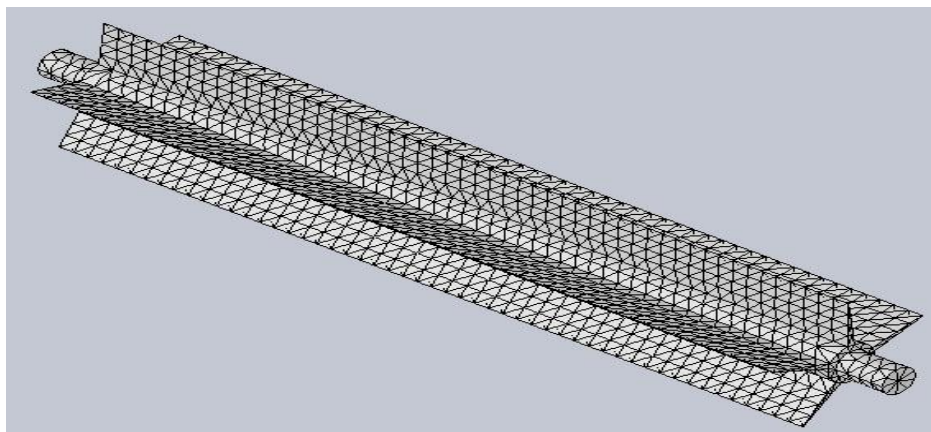

**Figure 4: Mesh design of the blade**

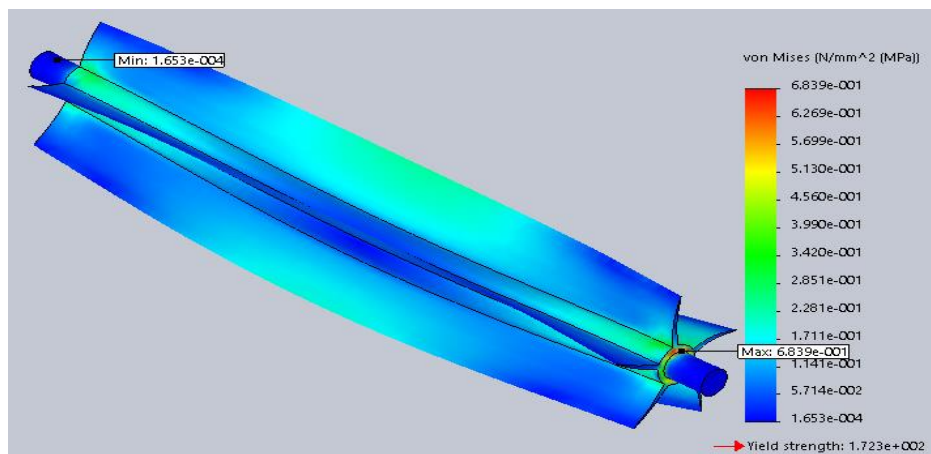

**Figure 5: Von Mises stress result of blade**



Result of the von Mises stress shows that every node of the blade is below the yield stress of the blade material. This means that the blade is expected to withstand fatigue failure due to pressure and forces exerted on it during operation. From the plot in Figure 5, it is seen that the yield strength of the material is 252 times greater than the maximum von Mises stress.

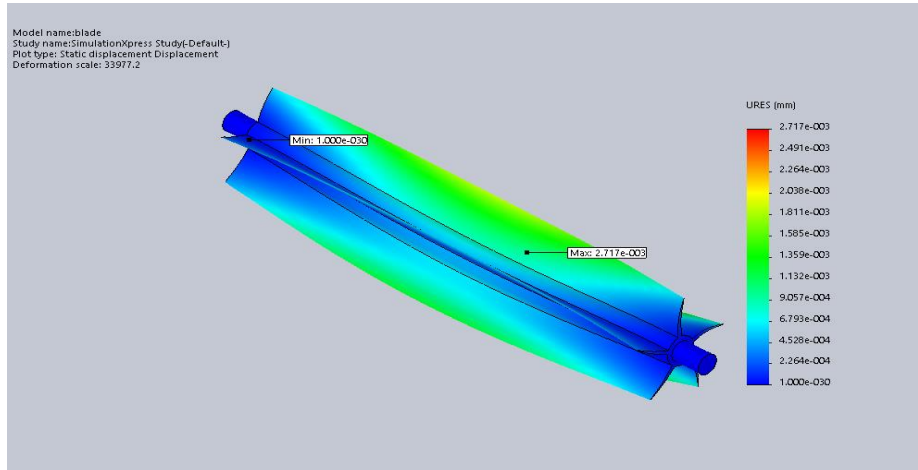

**Figure 6: Deformation Analysis**

The deformation result gives an indication of the extent at which the blade will deform due to its interaction with the work environment. From figure 6, we observe that the maximum displacement will occur at the tip of midsection of the blade. This observation is in line with the direction of blade rotation and the points of interaction with the work environment. However, with a maximum value of 0.00271mm, the deformation can safely be regarded as infinitesimal.

#### 4. CONCLUSION

The design and construction of a manually powered lawn mower as well as the stress and deformation analysis of the blade was presented in this work. Solid works software was employed for the development of the solid model of the design. Standard design and mathematical theories were utilized to obtain the specifications of the various parts. The cutting speed required for the cutting operation was achieved using standard gear arrangement, which transferred the rotational motion of the wheels to the blade and consequently increased the speed by about 300%. A cutting capacity of 62.48 m<sup>2</sup>/hr was achieved in the lawn mower design. From the stress and deformation analyses, the blade material can withstand the stress and deformation that is associated with the cutting operation.

#### REFERENCES

- [1] Sujendran S and Vanitha P. Smart Lawn Mower for Grass Trimming. *Int J Sci Res* 2014; 3: 299- 303.
- [2] Ibe G. Design of a Hand-held Grass Mower. *Int J Eng Res* 2017; 6: 116-119.
- [3] Rubentheran S, Linkesvaran S and Jeremy C. Design and Fabrication of Low Cost Portable Lawn Mower. *Sch J Eng Tech* 2017; 5: 584-591.
- [4] Yong and Chow, S.H. (1991). Design and Construction of an Improved Domestic Lawn Mower. Project Report; *Beijing Institute of Technology, China*.
- [5] Okafor B. Simple Design of Self-Powered Lawn Mower. *Int J Eng Technol* 2013; 3: 933-938. Mower. *J Eng Applied Sci* 2017; 12: 1254-1260.a
- [6] Hessayon D. G. (2007). The lawn Expert. Transworld Publishers, London. [http://en.wikipedia.org/history of the lawn mower](http://en.wikipedia.org/history%20of%20the%20lawn%20mower). Accessed 24-02-2022.
- [7] Okokpujie I, Okokpujie K, Ajayi J, et al. Design, Construction and Evaluation of a Cylinder Lawn
- [8] Mostafa M. S. (1995). Development and Evaluation of an Electrical Lawn Mower. Thesis, Department of Farm Power and Machinery, BAU Bangladesh

**International Journal of Novel Research in Electrical and Mechanical Engineering**

Vol. 11, Issue 1, pp: (14-23), Month: September 2023 - August 2024, Available at: [www.noveltyjournals.com](http://www.noveltyjournals.com)

- [9] Mohd Ishammudin Bin Mohd Yunus, (2008.) “Design and Development of Grass Cutting Machine Using DFMA Methodology”, *University Teknikal Malaysia Melaka*,
- [10] Daniyan I, Balogun V, Adeodu A, et al. Development and Performance Evaluation of a Robot for Lawn Mowing. *Procedia Manufacturing* 2019; 40: 42-48.
- [11] Shanmugasunda G, Yokes R, Yovaranjith S, et al. Design and Fabrication of Eco Friendly Pedal Operated Lawwn Mower for Agricultural Applications. *IOSR J Eng* 2018; 8: 12-17.
- [12] Desa Ahmad, “A Width of Cut Analysis on the Performance of a Rotary Strip Tiller”, *Pertanika* Vol. 9 No. I, 1986.
- [13] Ahamed M. S, Ziauddin A T M (2011) Development of small scale Electric Lan Mower. <https://www.researchgate.net/publication/260392618>
- [14] Okolie P, Obika E, Oluwadare B, et al. Steel work design and analysis of a 40-ton constant temperature hydraulic press. *Heliyon Elsevier* 2020; 6: 1-8.
- [15] Dutta P.P, Baruah A, Konwar A ,Kumar.V (2016) A Technical Review Of Lawn Mower Technology, ADBU-Journal of Engineering Technology ISSN: 2348-7305
- [16] Khurmi, R.S. and Gupta, J.K. (2003). Machine Design. *Eurasa Publishing House, Ltd. New Delhi, India*.
- [17] Nkakini S and Yabefa E. Design fabrication and evaluation of a spiral blade lawn mower. *Eur Int J Sci Technol* 2014; 3: 165-172
- [18] Nagarajan N, Sivakumar N and Saravanan R. Design and fabrication of lawn mower. *Asian J Applied Sci Technol* 2017; 1: 50-54.
- [19] Bello R, Baruwa A and Orisamuko F. development and performance evaluation of a prototype electrically powered brush cutter. *Int Letters Chem Phy Ast* 2015; 58: 26-32.
- [20] Ahmed M.S (2010). Development and Evaluation of an Electrical Lawn Mower, Published report, Department of Farm Power and Machinery. BAU Bangladesh