

PAPER • OPEN ACCESS

Clamp bending machine and annealed wire cutter for reinforced concrete columns

To cite this article: J Marron *et al* 2020 *IOP Conf. Ser.: Mater. Sci. Eng.* **758** 012020

View the [article online](#) for updates and enhancements.

Clamp bending machine and annealed wire cutter for reinforced concrete columns

J Marron¹, G Quispe², C Raymundo-Ibañez^{3,*}, Moises Perez⁴

¹ Facultad de Ingeniería, Universidad Continental, Lima 15046, Perú

² Ingeniería Industrial, Universidad Nacional Autónoma Altoandina de Tarma, Tarma 12651, Perú

³ Dirección de Investigación, Universidad Peruana de Ciencias Aplicadas (UPC), Lima 15023, Perú

⁴ Escuela Superior de Ingeniería Informática, Universidad Rey Juan Carlos, Mostoles, Madrid, España.

*carlos.raymundo@upc.edu.pe

Abstract. This study developed a reinforced steel rod bending machine for rods with diameters of up to 8 mm and annealed wire cutter for up to 5 kg for replacing manual intervention required to bend rods in reinforced concrete columns. This study aims to reduce the physical effort that could lead to occupational diseases, such as tenosynovitis, bursitis, muscle disorders. Clamp manufacturing possesses great risk for workers, who are exposed to injuries while using different cutting devices, such as grinders and electric saws. They also face potential problems such as muscular fatigue due to the nonergonomic and repetitive work positions. The proposed machine features a mechanical dragging and bending systems and manual shears. Additionally, the proposed machine has been designed theoretically and its effectiveness has been assessed through simulations conducted using the SolidWorks CAD software. A bending machine prototype for producing clamps is developed and its machine productivity is measured. Using this machine, approximately 300 clamps can be bent per hour without possessing any risk to the worker.

1. Introduction

Steel bars that are used as reinforcements in building and construction structures to prevent natural phenomena, such as earthquakes, are frequently used in Peru. Owing to the geographical location of Peru, such practice has become mandatory in all types construction works. Civil engineers, who are generally in charge of these projects, build structural plans, listing steel bar measurements and designs according to the requirements and needs of a particular construction project. When the construction is ready to commence, the best method for performing this task quickly, safely, and efficiently must be selected (Figure 1) [1].

This study presents one of the three alternatives that currently exist for the preparation of reinforcement steel bars for reinforced concrete as an alternative solution for the traditional model used today. This way, a more reliable, technical, and safe process may be implemented. This process would also allow for the production of shapes with diameters larger than standard, which cannot be created regularly due to the individual limitations of each worker [2] [3].



This project is expected to contribute to the improvement of construction techniques and creation of different shapes based on the proposed design of a machine that performs this work. This machine is described below based on data, plans, and guidelines [4].

2. Description

2.1. Reinforcing Steel

Reinforced concrete is defined as the material resulting from the union of cast concrete, i.e., a proportional mixture of Portland cement, or of any other hydraulic cement, with sand, gravel, and clean water with or without additives, which when setting and hardening becomes more resistant and armoring or reinforcing steel bars, combined in such a way that they create a solid, monolithic and unique element in terms of their physical characteristics, thus leveraging the individual features of both materials [5][6].

2.2. Annealed wire no. 16

Generally, wire is a filament or thin rod of a flexible metal with a uniform section. The metals usually used for wire production are copper, aluminum, steel, brass, iron, gold, silver, and platinum. Specifically, wire No. 16 is made of low carbon steel (Figure 2). The most modern methods for wire manufacturing consist of stretching a metal rod, passing it through increasingly thin, tapered holes, made of tungsten carbide dies, until the required diameter is obtained (wire drawing)[7][8][9].



Figure 1. Manual bending of rods



Figure 2. Annealed wire no. 16

2.3. Design and Construction

The design of the machine begins with the calculation of the bending force of the corrugated rods.

$$F = \frac{4 \cdot K \cdot \sigma_{\text{máx}} \cdot I}{L \cdot c} \quad (1)$$

To bend the rods, the formula of maximum flexion or effort is applied in relation to the plastic moment as follows:

$$\sigma_{\text{máx}} = \frac{M \cdot c}{I} \quad (2)$$

The necessary force required to bend the corrugated rod is calculated. For this calculation, the flexion formula was used, which was combined with the plastic factor.

To determine the bending force, the following indicators will be needed: maximum yield stress, inertia, supports length, distance from the neutral axis, and K factor. With this result, only the starting bending

force is calculated but the required result is not achieved yet. To achieve the expected result, weights must be applied to a mechanical lever system to determine the bending factor ($f_d = 1.32$) and, in turn, the total force.

The necessary force required to bend the corrugated rod is calculated as follows:

$$K = \frac{Mp}{P} \quad (3)$$

The cut separates the punch and screen that is embedded in a section of the material along an area defined by the periphery of both elements. The cut is a mechanical action that includes splitting or separating a longitudinal element or material into several parts without causing damages or producing shavings. Additionally, the sheet metal cutting formula is used.

$$V = T \cdot A \quad (4)$$

After bending and cutting calculations, the machine mechanism is designed by determining the most important forces, i.e., the driving and cutting forces. The cutting force meets the need and driving force is proportional to the torque provided by the reduction motor.

The following procedure and formula are used to calculate the required power:

$$M_T = \frac{63025,35 * P}{N} \quad (5)$$

where

MT = Torsion moment [kg.cm],

P = System power in [HP], and

N = Number of revolutions [rpm].

To calculate the required axis diameter, first, the existing forces of the axis and its flexing momentum are analyzed.

When assessing the position and direction of the forces, it is observed that all calculations are made using the XZ plane as a referential point. The force distribution is shown in Figure 3.

With this data, the axis diameter can now be calculated but not before selecting a safety factor of three due to design issues. Replacing this value in the equation, we have:

$$n_y = \frac{S_y}{\sigma_{m\acute{a}x}} \quad (6)$$

where

Sy = axis yield strength, as per AISI 1018 standards.

2.4. Operations and Parts

The machine will be designed to bend clamps and cut annealed wire number 16 using a 4 HP engine. The torque produced by a rotary movement is converted to a linear movement using a crankshaft-rod device, as shown in Figure 4.

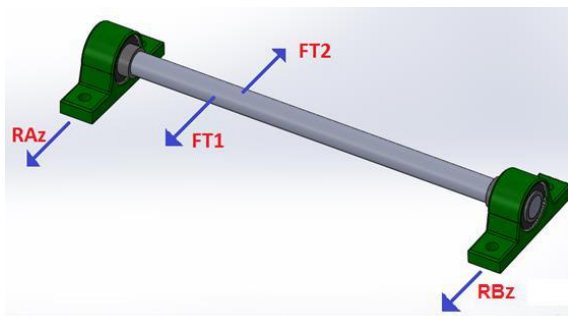

Figure 3. Distribution of Forces

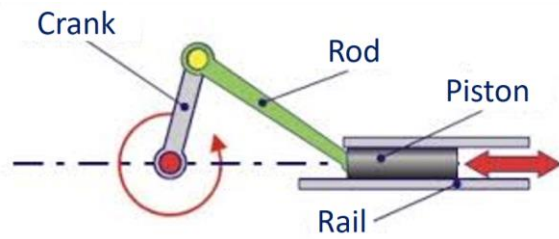

Figure 4. Crankshaft-Rod device

The force is transmitted to the bending arm, generating movement in the rear links, which move and create reactions necessary to cut the corrugated rod at the rear end of the machine.

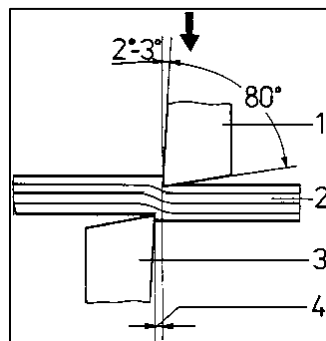

Figure 5. Shear cut

The main parts of the machine are cutting and bending systems, which are adjustable to the required limited distances.

3. Results

The machine will be designed to bend several clamps of up to 8 mm in diameter and cut annealed wires of up to 5 kg in different sizes.

In functional tests, 300 bent rods must be obtained in 1 h, which would increase production and improve the finishing and shape (Figure 6). In addition, these results must exceed the results obtained manually, implying that the worker is free to work in another activity for about 5 h, thus preventing fatigue and reducing operating costs.



Figure 6. Clamp bending machine

4. Conclusions

Based on the functional-technical criteria for the final design of the rod bender, the shape and dimensions of the machine were determined, along with the component strength required. Through the manufacturing criteria, steel profiles available in the market and used by local workshops were selected. Additionally, the economic factor has been important in the design, since the cost of profiles, screws, bearings, and other elements, as well as the manufacturing, must be affordable for the company.

One of the options that meets profile production needs is bending through semiautomatic machines since it bends reinforced steel bars, from smaller diameters to standard commonly used sizes.

The design of the clamp bending machine seeks to increase productivity, since an operator was able to bend 500 units manually per day, whereas the semiautomatic machine might bend 300 clamps in an hour. This will help prevent the physical exhaustion of workers.

5. References

- [1] CONFER S.A. ALAMBRE RECOSIDO COMPER. CONFER S.A. [En línea] [Citado el: 20 de 04 de 2019.] <http://www.comfer.com.pe/procesos/alambre-recocido-comfer/16/>.
- [2] Curbelio, Basilio J. 2015. CONCRETO ESTRUCTURAL. Quindio: Armenia, 2015.
- [3] DETERMINACIÓN DE LA RESISTENCIA A LA FLUENCIA DE UN ACERO AISI 1040. M. Torres, V. Di Graci y G. González. 2000. Caracas: RLMM, 2000.
- [4] Diseño de una máquina para cortar y doblar estribos en serie para columnas de hormigon armado. Pérez Silva, José Olger y Trujillo Zurita, Oscar Paul. 2016. 16, Quito: Zaimella, 2016. 1390-650X.
- [5] DUCTILIDAD Y TENACIDAD DE UN BORDE CORTADO POR PLASMA EN UNA CHAPA DE ACERO S460M. J Aldazabar, y otros. 2014.
- [6] G. Budinas, Richard y J. Keith, Nisbett. 2008. DISEÑO EN INGENIERÍA MECÁNICA DE SHIGLEY. MEXICO: MCGRAWHILL, 2008.
- [7] G. Budynas, Richard y J. Keith, Nisbett. 2008. DISEÑO EN INGENIERÍA MECÁNICA. MEXICO: MC GRAW-HILL INTERAMERICANA, 2008.
- [8] Máquina dobladora para fabricar estribos cuadrados de varilla trefilada de acero de 6 mm de diámetro. Guerrero, Diego. 2017. Ibarra : FICA,, 2017.
- [9] Trujillo Zurita, Oscar Paul. 2014. DISEÑO Y CONSTRUCCIÓN DE UNA MÁQUINA PARA CORTAR Y DOBLAR ESTRIBOS EN SERIE PARA COLUMNAS DE HORMIGON ARMADO. QUITO: s.n., 2014.